

79 Series Multi-housing Lock



INSTALLATION GUIDE

79 Series Multi-housing Lock

ASM, ESM, ASM Auto Deadbolt Mortises &
Cylindrical Models 2³/₈" and 2³/₄" Backset

Table of Contents

1. Introduction and Disclaimers	2
2. Checklist and Exploded Views	
2.1. Parts and Tools List	3
2.2. ASM/ESM 79M Standard Mode	4
2.3. ASM/ESM 79T Toggle Mode	5
2.4. Autodeadbolt; ASM Inside Trim Assembly 79T	6
2.6. Inside Trim Assembly for 79T Toggle Mode Cylindrical	6
3. Installation of Standard ASM or ESM Models	
3.1. Check the Mortise Handing	7
3.2. Install the Strike	8
3.3. Install the Mortise	9
3.4. Install the Outside Housing & Inside Trim Assembly without key override	10
3.5. Reversing the Outside Lever	11
4 Lock Testing	12
5. Lock Programming	13
6. Installing the Mechanical Override	15
Appendices	
A. Mortise Models	
A.1. Reversing the Mortise Handing	23
A.1.1. Reversible ASM	24
A.1.2. Reversible ESM	26
A.2. Additional Steps for Autodeadbolt ASM for 79M Standard Mode only	28
A.3. Additional Steps for ASM Office for 79M Standard Mode only	29
A.4. Additional Steps for ASM/ESM Storeroom for 79M Standard Mode only	29
B. Cylindrical Models	
B.1. Installing Cylindrical Models	30
B.1. Install the Strike.	30
B.2. Install the Latch.	30
B.3. Install the Cylindrical Unit	31
B.4. Inside Trim Assembly	32
B.5. Install Outside Housing & Trim Assembly	33

Note: This installation Guide is for the 79 Series Multi-housing lock. Images of the lock may be different than your model. See photo on front cover.

1 • Introduction and Disclaimers



Please read and follow all directions carefully.

Target Audience

These instructions are designed for use by maintenance professionals or lock installers who are familiar with common safety practices and competent to perform the steps described. Kaba Lodging Systems is not responsible for damage or malfunction due to incorrect installation however arising.

Definition of Terms

In these instructions, the term ASM refers to American Standard Mortise, ESM refers to European Slim Mortise, and ADB refers to Autodeadbolt Mortise.

Technical Assistance

For technical assistance, call: 1 800 906-4526 / +1 514 340 9025

Warnings and Cautions



Important: Carefully inspect windows, doorframe, door, etc. to ensure that the recommended procedures will not cause damage. Kaba Lodging Systems standard warranty does not cover damages caused by installation.



Important: The gap between the mortise front plate and the strike must **not exceed** 3/16"

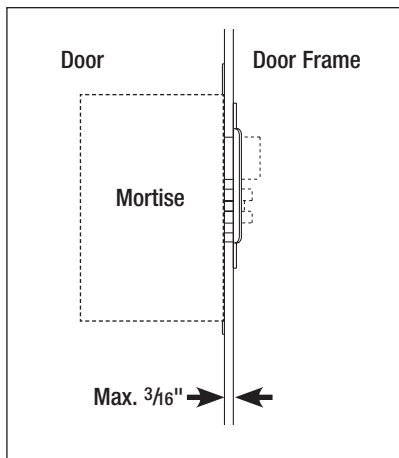

Caution: Wear safety glasses when making the holes.

2 • Checklist and Exploded Views

2.1 Parts and Tools List

Each lockset includes:

- (A) Outside lever handle
(or)
Parts for Mechanical override model only:
(A1) Outside lever handle
(B1) Outside housing 79M Standard mode or B3 for 79T Toggle mode
(C1) Cylinder plug
(D1) Cylinder (79M Series with cylinders keyed different only)
(E1) Cylinder cap
(E2) Instruction sheet "How to attach lever on lock"
- (B) Outside housing 79M Standard mode
(B2) Outside housing 79T Toggle mode
(C) Battery holder with 3 AA batteries
(D) Mortise (ASM only shipped assembled with faceplate and 2 x 8-32 x 1/4" screws)
(or)
Parts for cylindrical models (see illustrations in appendix B):
- cylindrical latch (see B3 page 31)
- cylindrical unit assembled with one pair of screws & 3 spacers
- four (4) other pairs of screws & 3 spacers in hardware bag
- additional extension spring
(E) Inside trim assembly, details depend on lock model (see 2.2, 2.3, 2.4, 2.5, 2.6, A2, A3, A4)
(E2) Inside Trim assembly for 79T Toggle mode (see 2.4 & 2.6 at page 6)
- (N) Outdoor gasket to be ordered. **ESSENTIAL FOR OUTDOOR INSTALLATIONS**
(N1) Tension Spring

Parts inside hardware bag:

- (F) Thumbturn (hex) spindle
(G) Square spindle
(H) Torx-head screw
(I) 3 x mounting screws (10-24, 1/8 Hex Head) or (12-24, 1/8" Hex Head for recent models only)
(J) 2 Machined screws (12-24X 1/2" Philips) & 2 wood screws (#12 X 1" Philips)
(K) Strike kit (screws, strike and ASM or Cylindrical dustbox)
(L) 1 extension spring
(M) Parts required to control thumbturn motion
(Q1) 4 pairs of Flat Head Screws 10-24 (for cylindrical only)
(R1) 3 Spacers (for cylindrical only)
(R2) 1 Cylinder with 2 keys for locks with override and cylinders keyed different only
(S) 3 spacers (see page 28) for recent Models only

Tools Required:

Safety glasses	2 1/8" (54mm) hole saw (Cylindrical Only)	Mortise faceplate router template
1/2" (13mm) chisel	Hammer Rubber mallet	Adjustable square
1/8" (3mm) drill bit	Small flat screwdriver	Tape measure
1/4" (6.5mm) drill bit (ESM only)	Torx screwdriver (T-15)	Pencil
1/2" (13mm) drill bit	Phillips screwdriver (#2)	Tape
7/8" (22mm) drill bit or hole saw	Fine steel file	Cleaning supplies (drop cloth, vacuum)
Drill	Mortising machine	Spanner screwdriver #6
Awl or center punch	Router	
3/4 (19mm) drill bit		



For doors more than 2 1/2" thick up to 3 3/4", order the appropriate hardware bag to receive the correct length of spindles and mounting screws. Part# 062-510189-XXX; (XXX = choice of finish).



For outdoor installations, order gasket 033-512017-1.

2.2 ASM, ESM, 79M Standard Mode (For Cylindrical, see Appendix B)

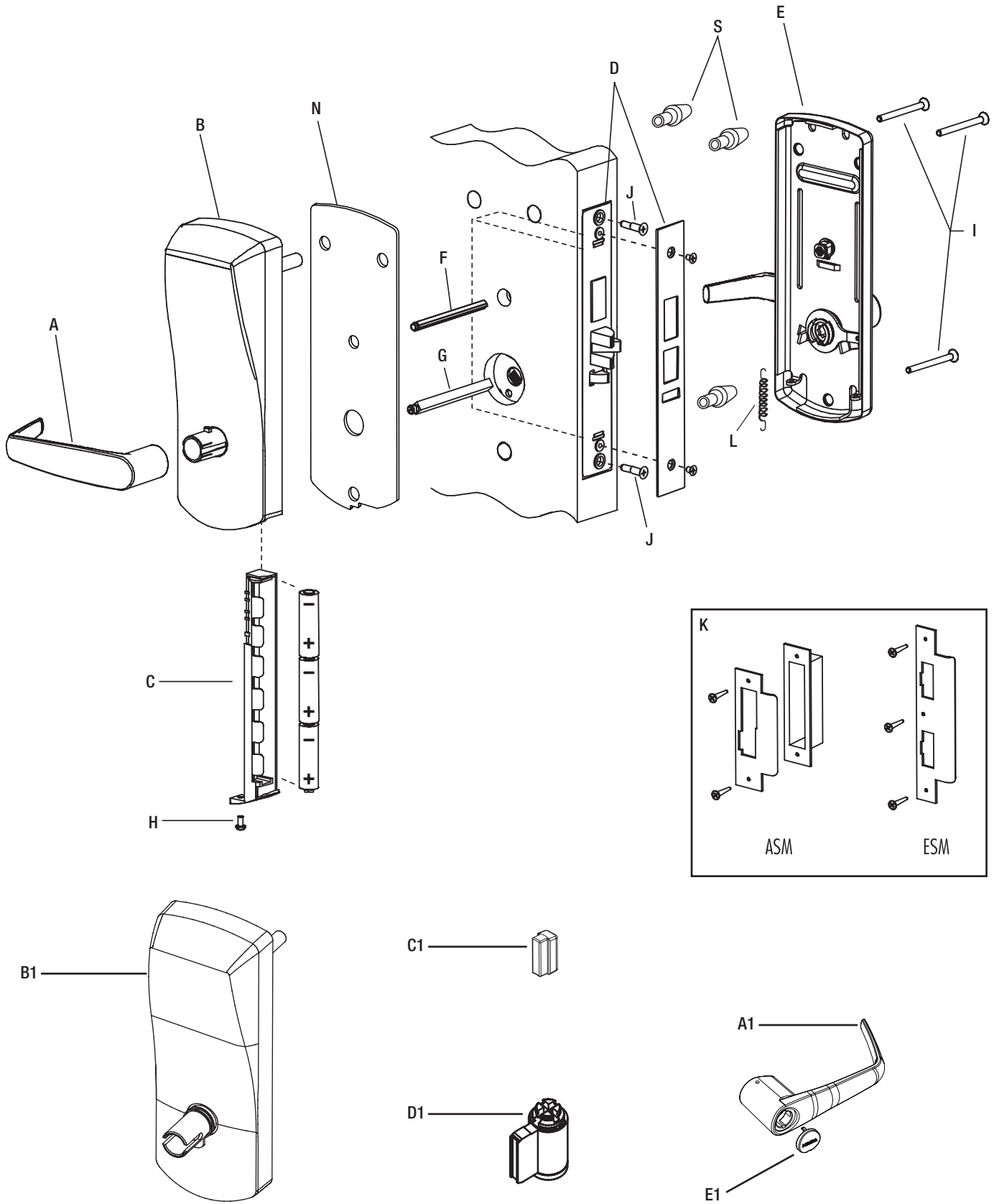

Notes: D: American Standard Mortise illustrated.

2.3 ASM, ESM, 79T Toggle Mode (For Cylindrical, see Appendix B)

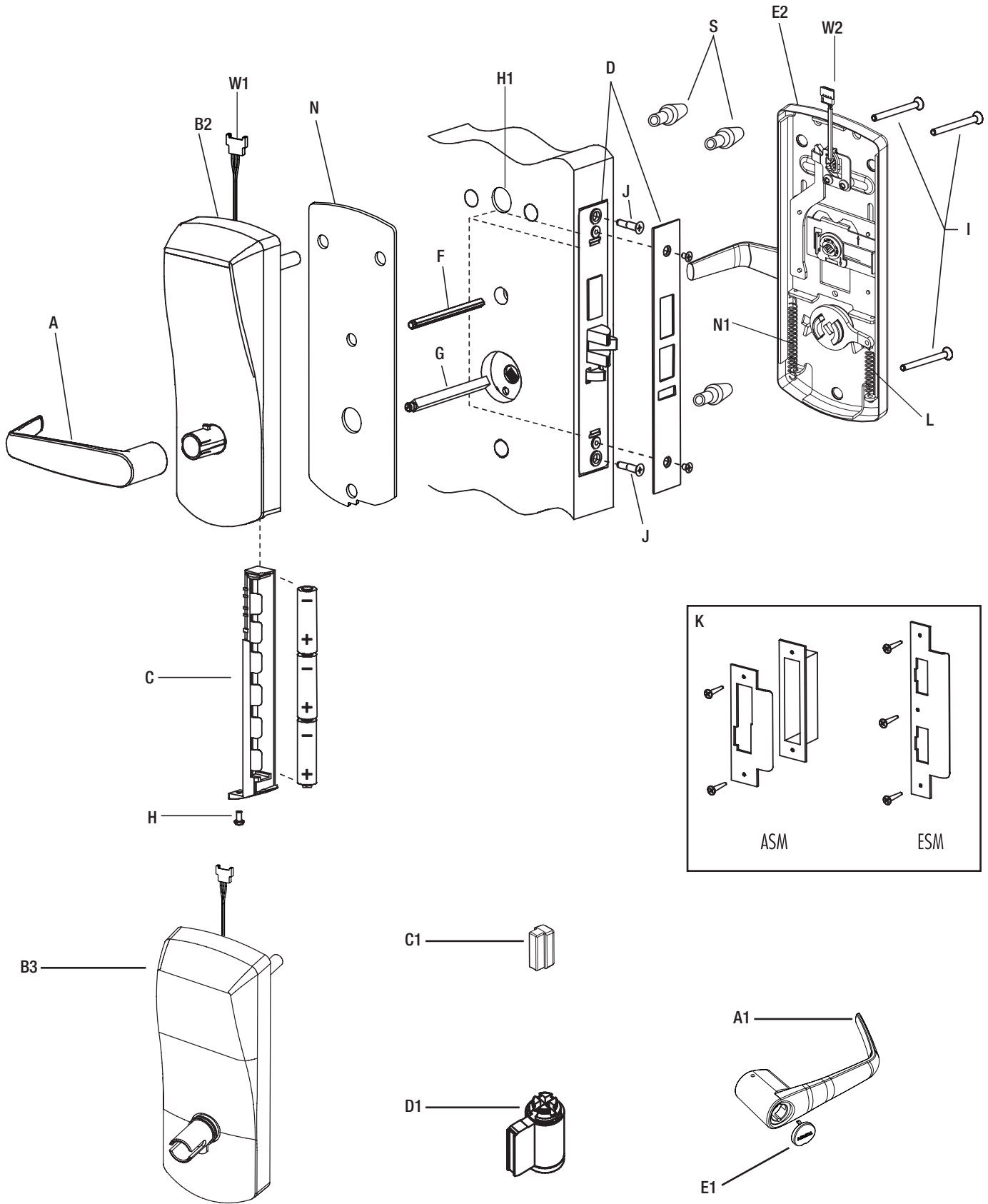

Notes: D: American Standard Mortise illustrated.

2.4 Autodeadbolt; ASM Inside Trim Assembly for 79T (Toggle Mode)

(for 79M standard mode with Autodeadbolt; ASM Office and ASM/ESM Storeroom models, use parts (M) as shown in Appendix A2)

NOTE: The inside trim assembly (E) for ASM and ADB on 79T models includes the parts (M) as shown below. **Position of stopper M2 is very important**

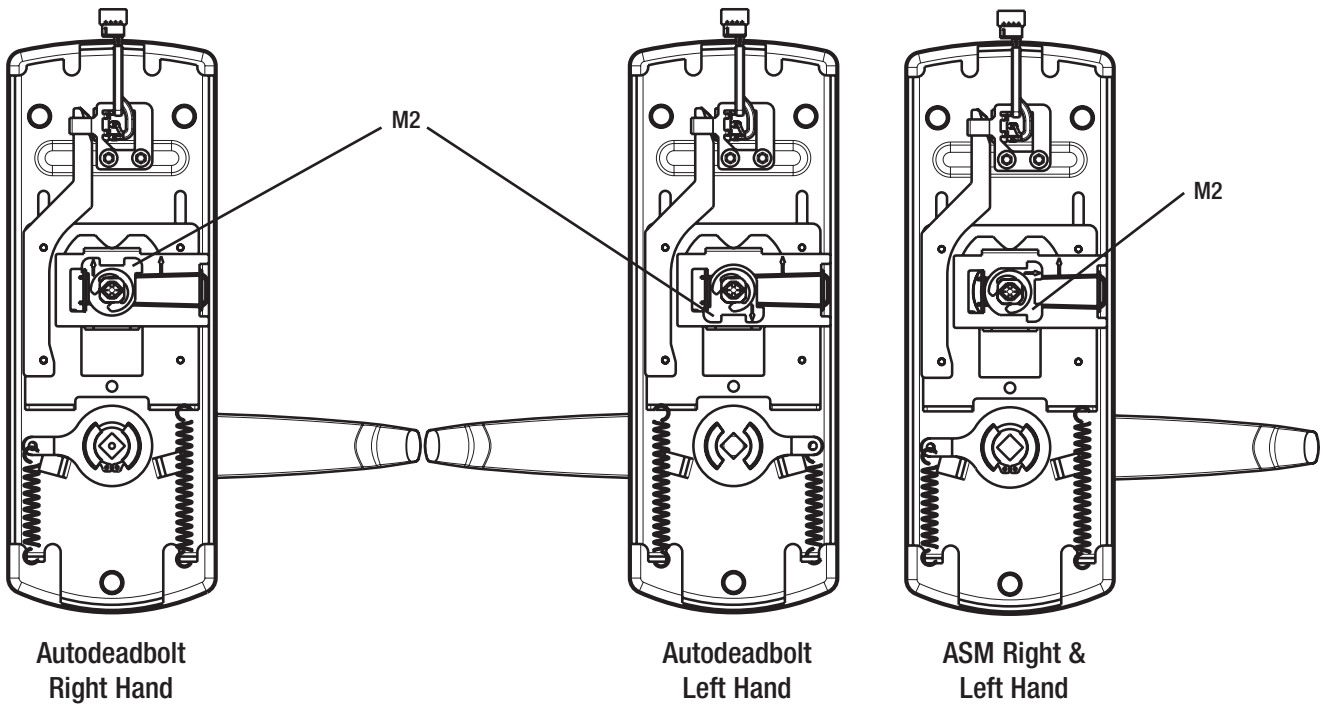

2.5 Cylindrical Unit and Inside Trim Assembly for 79M Standard Mode see Appendix B

2.6 Inside Trim Assembly 79T Toggle Mode Cylindrical

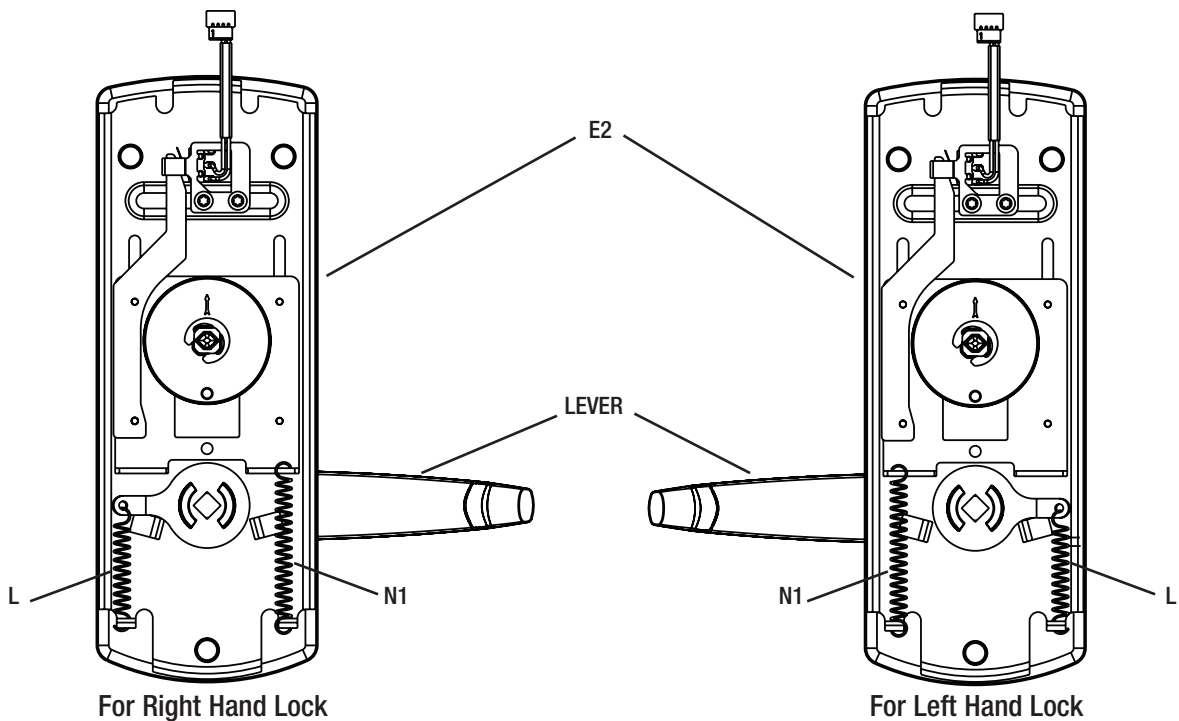

3 • Installation of Standard ASM OR ESM Models

3.1 Check the Mortise Handing

Compare the mortise with the diagram below. If the mortise is the correct handing for the door, continue with step 3.2.



Refer to Appendix A.1 to change the handing of a field-reversible mortise.

ASM

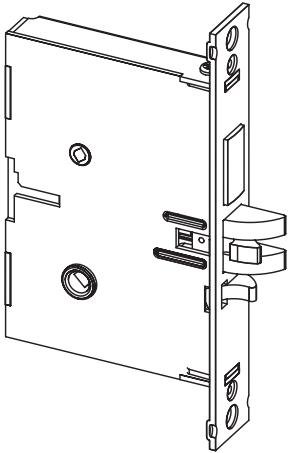

For LH (left hand) and RHR (right hand reverse)

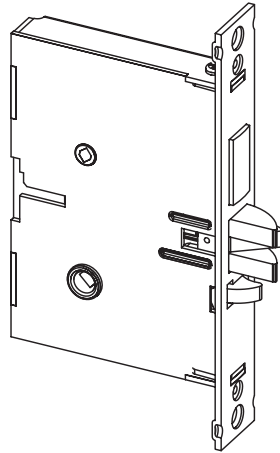

For RH (right hand) and LHR (left hand reverse)

ESM

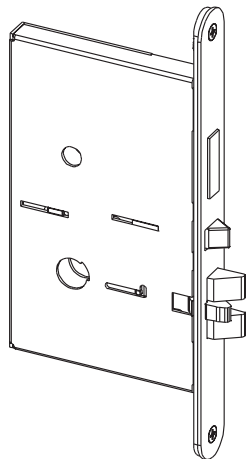

For LH (left hand) and RHR (right hand reverse)

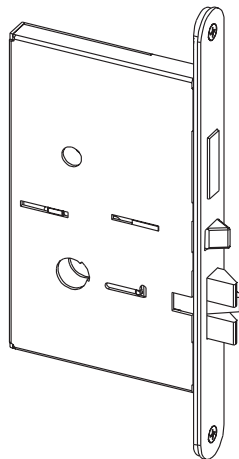

For RH (right hand) and LHR (left hand reverse)

Door Handing (Top View)

Right Hand (RH)

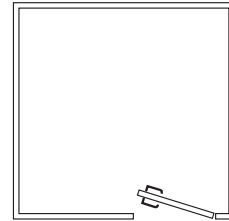

Left Hand (LH)

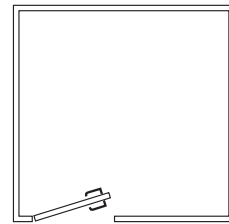

Right Hand Reverse (RHR)

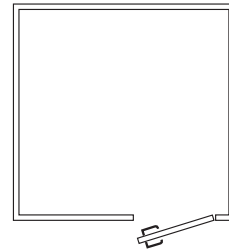

Left Hand Reverse (LHR)

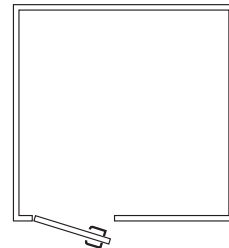

3.2 Install the Strike

1. Align the paper template on the door frame at the desired handle height (↖), and along the vertical center line of the mortise (CL), which is also the center line of the door edge, allowing for any bumpers on the door frame.

 **Respect applicable building codes regarding handle height.**
Note that the centerline of an ESM mortise does NOT pass through the screw holes on the strike.

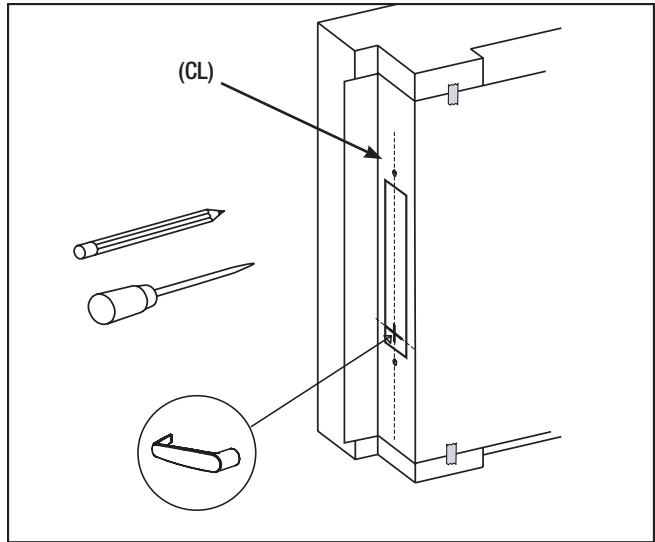

2. Mark the locations of the dust box cutout and mounting screws for the strike.

3. Mortise the door frame to receive the dust box, and drill the pilot holes for the mounting screws (dimensions and depths marked on template).

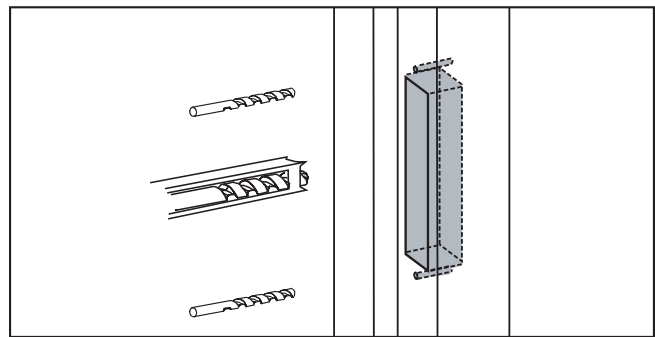

4. Position the strike against the doorframe and align it with the mounting screw holes. Trace the outline of the strike.

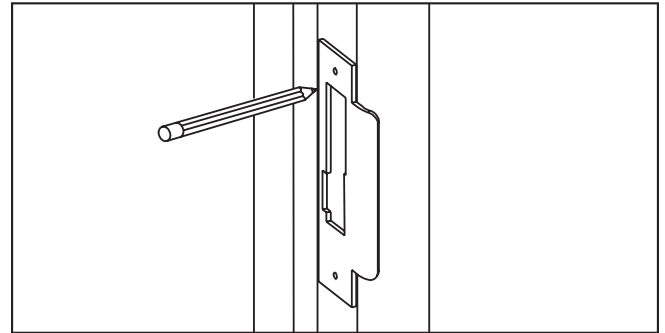

5. Remove material from within the strike outline so that the strike will be flush with the doorframe.

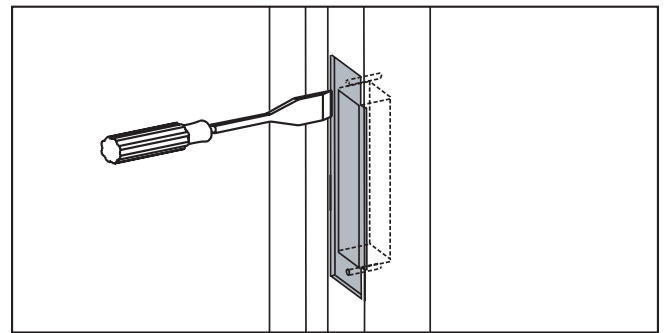

6. For ASM, install the dust box (optional for wood door frames, required for metal door frames), and check the strike handing on the template. Install the strike using the screws provided. Use wood screws for wood frame and machine screws for steel frames.

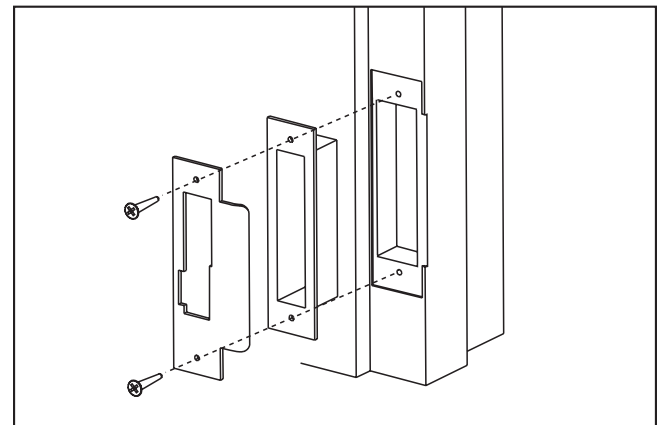

 **When strike is installed on wood frames under one inch thick, wood screws supplied are not adequate. use screws of efficient length to engage the structural stud behind the frame. Use only the strike and dust box supplied. Use of non-approved parts may void the warranty.**

3.3 Install the Mortise



If using the installation jig to prepare the door, refer to the instructions provided with the jig, then proceed with step 6 below.

1. Mark the handle (🔑) height on the edge of the door, as determined directly from the strike.

For ASM, the axis of rotation of the handle is level with the bottom lip of the strike.

For ESM, the axis of rotation of the handle is 1-1/4" above the bottom lip of the strike.

For cylindrical models, see B2 in Appendix B

2. Align the template along the vertical center line of the mortise (CL) at the desired handle height, and tape it to the door. Mark all holes and cutouts for the mortise in the edge of the door and remove the template.

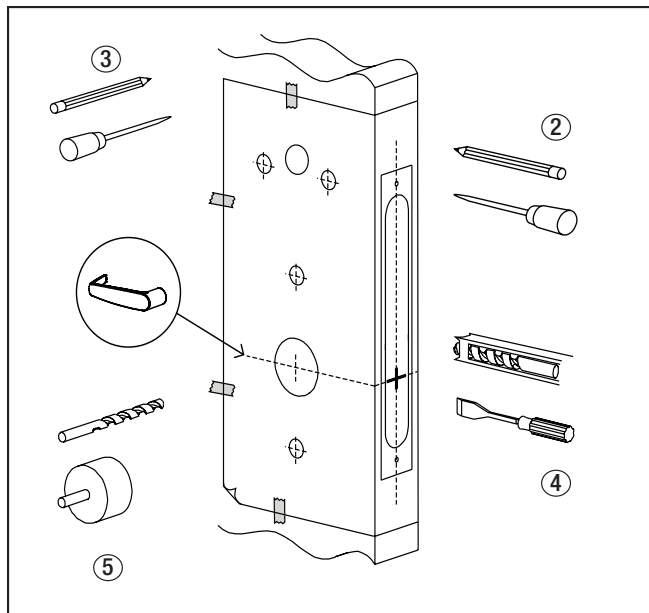
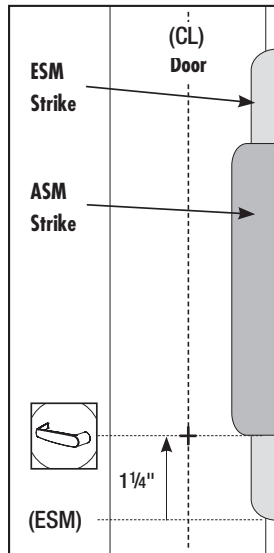

3. Locate the two sets of vertical fold lines on the template allowing you to adjust the positioning of the template depending on the bevel of the door.

If the door has no bevel, fold the template along the solid lines. Align the fold with the edge of the door and mark the holes for the lock. Repeat on the other side of the door.

If the door has a 3° bevel, fold and align the dashed line marked "H" on the template with the higher-beveled edge of the door and mark the lock holes on that side of the door. Repeat on the side with the lower-beveled edge using the dashed line marked "L". Remove the template.

4. Prepare the cut-outs for the mortise in the edge of the door using a mortising machine, router and chisel (for dimensions, refer to template).

Ensure clearance is provided for moving latch parts as indicated on the template.

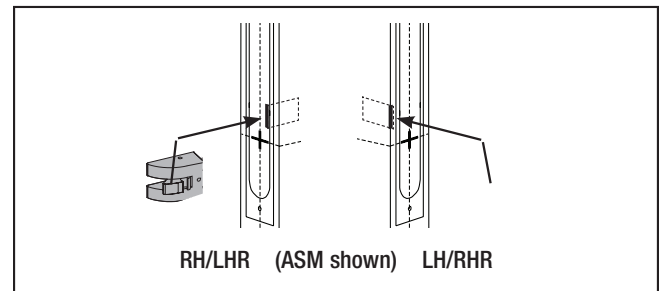

5. Drill the holes in the sides of the door (for dimensions, refer to template).



Drill from both sides of the door to prevent unsightly damage

6. For ASM only, check the bevel of the mortise. If adjustment is required, loosen bevel screws (R) and adjust mortise front plate angle to match the bevel of the door. Re-tighten screws.

Install the mortise with 2 screws (Q). Use wood screws for wood doors and machined screws for steel doors.

Install mortise faceplate (P) with the two 8-32 x 1/4" screws provided.

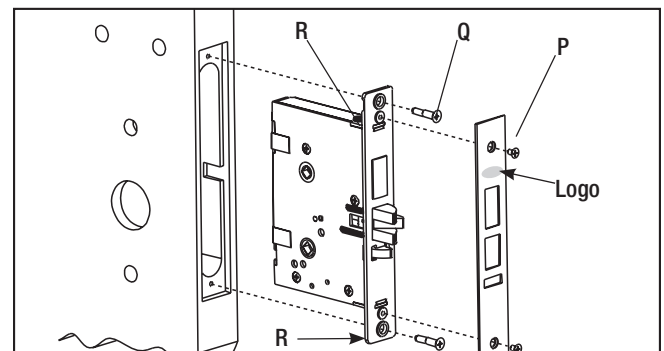

The ESM faceplate must be installed so you can read the logo (see arrow in figure above right-side-up for proper operation.)

3.4 Install the Outside Housing and Inside Trim Assembly for 79 Series (for 79 with Mechanical Override, see page 15)

A- For Mortise

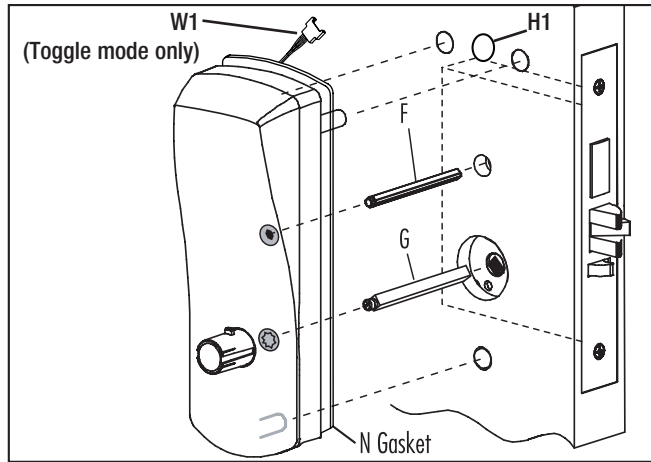

1. Install the gasket (N) (if required) on the outside housing prior to assembly, aligning the notch in the gasket with the battery compartment. See page 3 for gasket information.

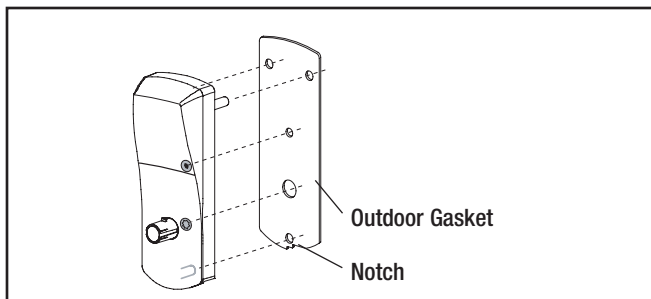

2. Insert the slotted end of the square spindle (G) into the outside lever hub until it locks, at an angle of 45°. (The spindle can be removed by pulling on it, if oriented incorrectly.)

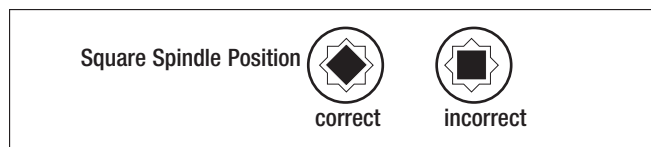

3. Insert the thumbturn spindle (F) in the upper hub of the outside housing. (It will clip in place.)

i If installing the lock with mortise outdoors, order the proper Gasket (See page 3).
For doors more than 2 1/2" thick, order the appropriate hardware bag to receive the correct length of spindles and mounting screws. (See page 3)

4. Place the outside housing on the door so that the spindles engage the hubs on the mortise.
For 79T Toggle Mode, insert cable W1 in hole H1 on the door (See fig. above)

5. On the inside trim assembly turn the lever to the correct horizontal rest position for the handing of the door. Install the tension spring (L) between the handle (H) and the post (P).

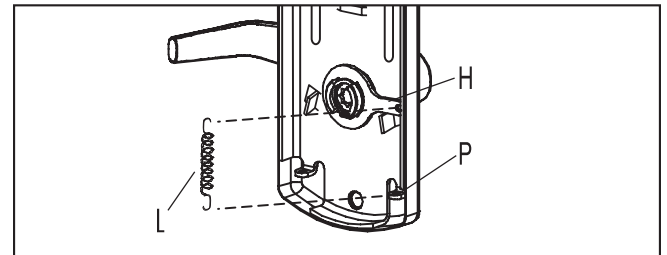

! For 79M with ASM Office and ASM/ESM Store-room models, refer to Appendix A.2, A.3, A.4 at this point.
For 79M Cylindrical, refer to Appendix B.
For 79T Toggle Mode, see 2.6 on page 6

5. Put the thumbturn (T) in a vertical position. Place 3 spacers (S) on the door (for recent models only) and place the inside trim assembly on the door so that the upper and lower spindles (F) and (G) engage the thumbturn and the inside lever. Fasten to the outside housing using the three 1/8" hex drive mounting screws (I). Install the screws without tightening. Verify the inside lever and thumbturn operates smoothly. If not move the inside and outside housings slightly. Then tighten the screws.

For Autodeadbolt only, apply the privacy thumbturn sticker as shown. If in doubt as to the direction of the arrow press the auxiliary latch (X) to extend the deadbolt, and verify in which direction to rotate the thumbturn to reach the horizontal (privacy) position.

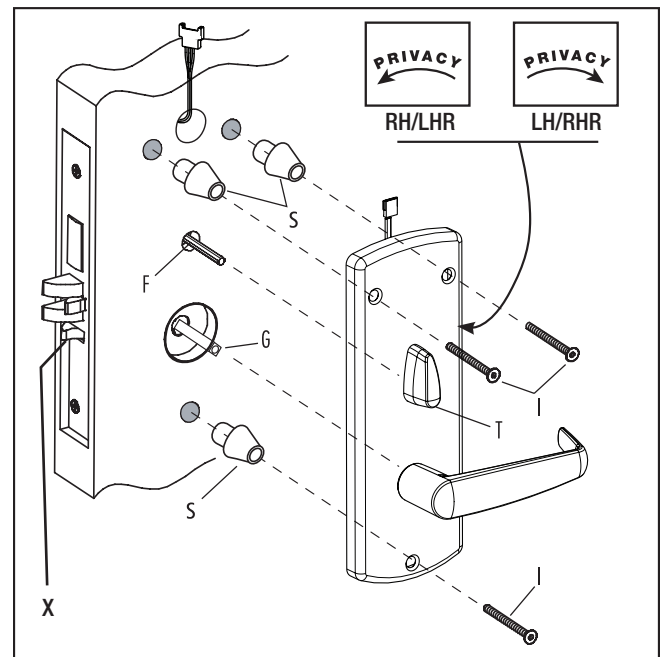

6. Assemble the lever on the outside housing, in the horizontal rest position appropriate to the handing of the door. Simply push the lever onto the tube until it clicks in place. If more force is required, use a rubber mallet. Test the attachment of the handle by pulling smartly on it. (For locks with mechanical override, see p.15)

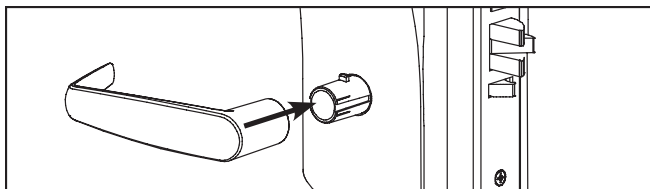

7. Three AA batteries should already be installed in the battery holder (C). Insert the battery holder into the outside housing and secure it using the 6-32 x 5/16" (7.9mm) Torx drive screw (H).

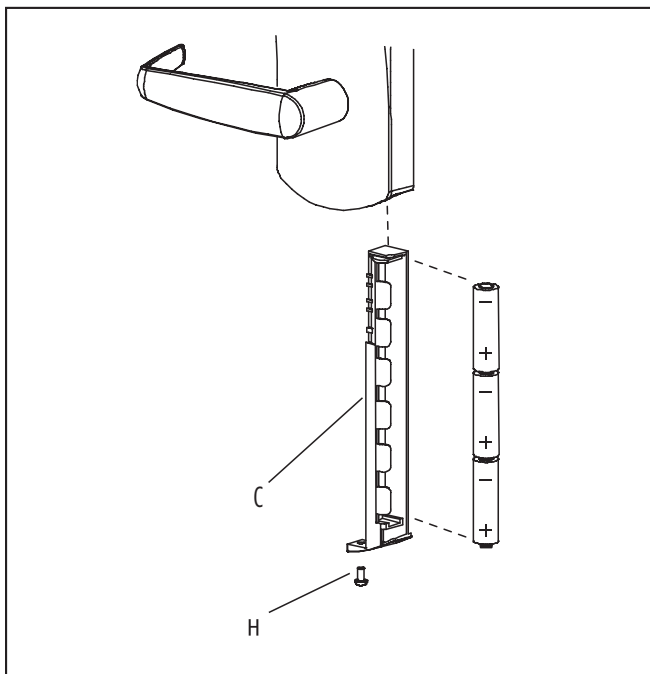

3.5 Reversing the Outside Lever (for Series without Mechanical Override)

The lever is field reversible. If the handing is incorrect, insert a small pick or flat screwdriver in the hole in the hub as shown. Gently pry back the spring clip inside the hub, and remove the handle.

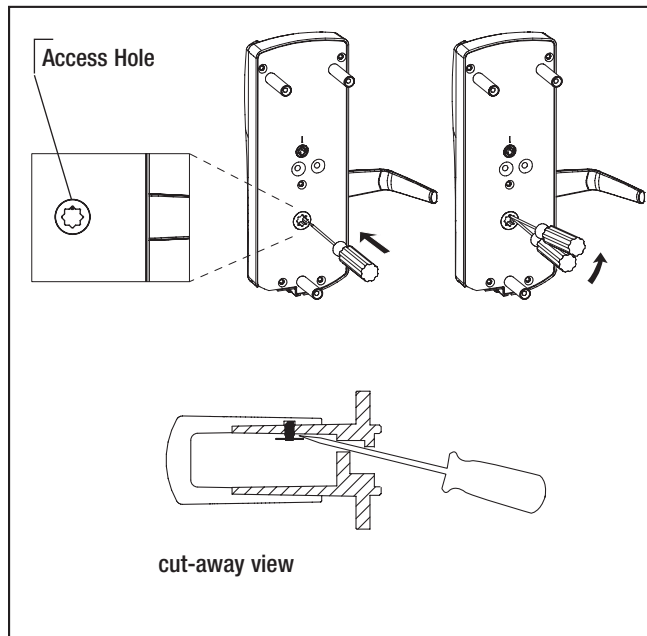

3.6 For Cylindrical, see p.29

! If the lock makes a continuous buzzing noise or the red LED lights continuously, reset the electronics by removing the battery holder for ten seconds then reinsert it.

4 • Lock Testing For mechanical override testing , see Step 8 Page 19



Caution! Perform the following procedures in order, with the door OPEN unless otherwise indicated.

Inside Lever:

Turn the inside lever downward. The latch bolt retracts fully.

If the lever or the thumbturn feels tight (hard to turn or does not return easily to its horizontal position), check the alignment of the lock assemblies. Loosen the mounting screws and shift the inside trim assembly slightly until the friction is eliminated. If the problem persists check the position of the holes on the door (compared to the mortise).

Standard Deadbolt:

Turn the thumbturn back and forth. The deadbolt extends and retracts fully and without undue friction.

Turn the thumbturn to extend the deadbolt again then turn the inside lever. The deadbolt and the latch bolt retract simultaneously and fully without undue friction.

Optional Autodeadbolt:

Press and hold the auxiliary bolt (X). The deadbolt (D) will extend. Keep the auxiliary bolt depressed, and turn the inside lever all the way down and hold it there. The latch (L) and deadbolt retract together.

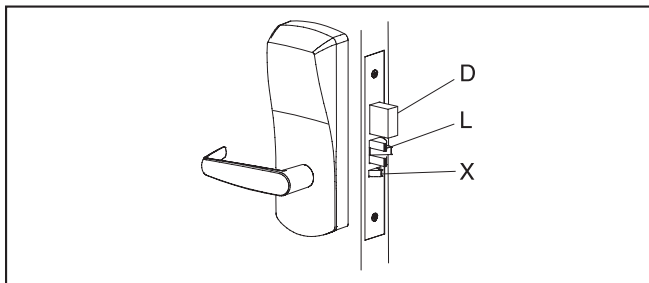

Release the auxiliary bolt (X), then let the inside lever return to a horizontal position. The deadbolt will remain retracted while the latch will extend.

Outside Lever:

Turn the outside lever downward. The latch bolt does not retract.

If the latch bolt retracts, verify that the batteries are properly installed.

If the lever feels tight (hard to turn, or does not return easily to its horizontal position), ensure the square spindle is not too long.

Electronics and Card Reader:

Test the lock's response to keycards: a Test keycard, a Grand Master keycard, and an Emergency keycard. Present card to reader.

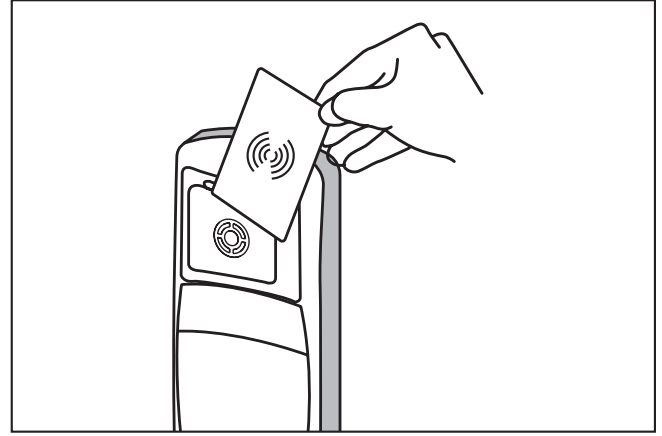

A. Test the Lock Before Programming

Normal Entry: Verify that the deadbolt is retracted. Present test keycard to reader. The red and green LEDs each flash once and then the green LED flashes for four seconds.

Turn the outside lever downward while the green LED is flashing. The latch retracts fully. Release the lever then turn it again after the LED stops flashing. The latch must not retract after the LED stops flashing without first presenting the keycard.

Privacy Switch: Turn the thumbturn to the horizontal position. (On autodeadbolt models, first extend the deadbolt by pressing the auxiliary latch (X). On storeroom locks, skip this test.) Use the Test keycard in the reader but do not turn the lever. Instead of the normal sequence of indicator lights you should see the following: the red and green LEDs each flash once and then the green LED flashes once, followed by the red LED flashing continuously for four seconds. If you see the flashing green LED there is a problem with the privacy switch.

B. Privacy Function: Lockout of Keycards

Turn the thumbturn to the horizontal position for privacy. (On autodeadbolt models press and hold the auxiliary latch (X) to extend the deadbolt, then turn the thumbturn for privacy. On storeroom locks, skip this test.)

Present the Grand Master Keycard to the reader. The red LED flashes once. Then turn the outside lever downward. The latch does not retract.

C. Emergency Keycard Access: Deadbolt Override

Present the Emergency keycard to the reader. The red LED flashes for 4 seconds. Turn the outside lever downward while the red LED is flashing. The deadbolt and latch bolt retract simultaneously and fully.

While standing outside the room close the door and ensure that it is properly latched. Open the door using the Grand Master keycard using the same procedure.

D. Inside and Outside Lever Detection for 79T Toggle Mode only.

Before fastening the inside trim assembly to the outside housing assembly, check that the lever switch (W2) is well connected to the wire harness (W1) (see p.5). Check that the thumbturn (T) is in the vertical position as shown in step 5 page 10.

Present the emergency card to the reader. (The LED will flash for 4 seconds). Rotate the lever as soon as the LED starts flashing - The LED will stop flashing. If it does not, there is a problem with the lever detection

5 • Lock Programming

Once a lock is correctly installed on the door and the battery pack inserted, it will go into locked mode (always locked). In this unprogrammed state (virgin mode), a lock can be unlocked using one of the **Test Keycards** provided in a pack with the installation equipment. While in virgin mode, the lock has no address or date/time and will relock automatically after 4 seconds once unlocked using a Test Keycard.

Locks need to be programmed to give them their door ID, to synchronize them with the system date and time and program them with all of the property setup settings (employees, sub-master levels, etc.)

Deadbolt Deactivation:

A. Deadbolt Deactivation by Thumbturn

While standing inside the room, close the door, and then turn the thumbturn to extend the deadbolt. (If the lock has an auto-deadbolt mortise go to step B below).

Turn the thumbturn to retract the deadbolt. Repeat.

B. Deadbolt Deactivation by Lever

While standing inside the room, close the door and turn the thumbturn to the horizontal position to extend the deadbolt (or to select privacy on autodeadbolt models). Open the door by turning the lever. The deadbolt and the latch bolt retract simultaneously and fully. Take note of any excess friction which might necessitate filing the strike (deadbolt area only). Repeat.

Once ATLAS-Multi-housing is installed on the dedicated laptop or PC and the property's System Setup has been configured by the customer, locks are programmed using a Maintenance Unit (M-Unit) and an Infrared Programming Module (IPM).

STEP 1 - Create Lock Configuration File

Log in to ATLAS-Multi-Housing and select **Transfer Files M-Unit > PC** from the main **Admin** menu

Select Expiry for the length of time you want the files to remain in the M-Unit. 24 hours is the default

If you select "Yes" to Electrical Override, another field "Number of Overrides" appears, enabling you to limit the maximum

number of times lock electronic overrides can be performed with the M-Unit before resynchronization

Select unit(s) from list that appears when you click on the tree at right

Click on Save

The folder to hold your files to transfer to the locks, is called ATLAS M-Unit and is located in the Main folder for your ATLAS application

Leave the default name that shows the date the file was created. The extension is .lcf for “lock configuration file”

Click Save

STEP 2 – Create Initialization and Programming key-cards

An **Initialization keycard** initializes the lock during a first-time installation, or after an interruption of battery power (e.g. during a battery replacement, or whenever the battery power is temporarily disconnected).

Log in to ATLAS-Multi-Housing and select **Make keycards** from the main **Staff** menu

Select **Initialization** from the drop down menu

Enter the number of cards required

Placed the keycards on the encoder

Clear label the **Initialization keycards**

A **Programming keycard** prepares the lock for communication with the M-Unit. If the lock has never been initialized, the Initialization keycard must be presented to the lock prior to the Programming keycard. If communication with the lock does not begin within 30 seconds, the lock will return to the normal state with no changes to its programming.

Log in to ATLAS-Multi-Housing and select **Make keycards** from the main **Staff** menu

Select **Programming** from the drop down menu

Enter the number of cards required

Placed the keycards on the encoder

Clear label the **Programming keycards**

STEP 3 - Synchronize ATLAS-Multi-Housing with the M-Unit

Turn on M-Unit

Ensure that your M-Unit is connected directly to the USB port

Click on the HotSync icon and you will receive a message that the HotSync is in progress

Return to the main screen by clicking on the **Applications** icon

STEP 4 - Program Infrared Programming Module (IPM)

Go to the main page of the ATLAS application on the M-Unit

Login with the same name and password you use for the main application

Click on **ATLAS** at top left, and it changes to **Tools**, with a dropdown menu

Select **IPM** from the pulldown menu under **Tools**

Click on **IPM Configuration**. A list of available IPMs appears

Select the IPM you want to use

Click on **Program** and hold the M-Unit up to the IPM you are programming. The M-Unit must be at least 2” away from the IPM and the panel on top of the M-Unit must be parallel to the IrDA window (small red glass panel) in the IPM, with the M-Unit screen facing upwards.

STEP 5 - Program Lock

Click on **ATLAS** on the M-Unit screen

Tap on **Doors**. The list appears with all the lock numbers that need to be programmed

6 • Installation of Mechanical Override Model

Parts and Tools List

Tools Required:

Cylinder (J, provided with lock) or equivalent (T) Small flat scwdriver (less that 1/8")

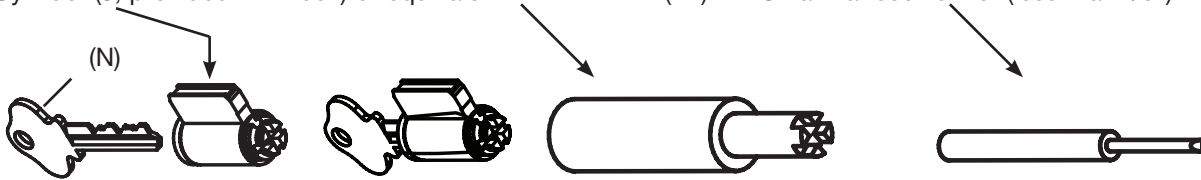
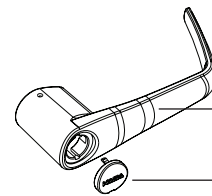
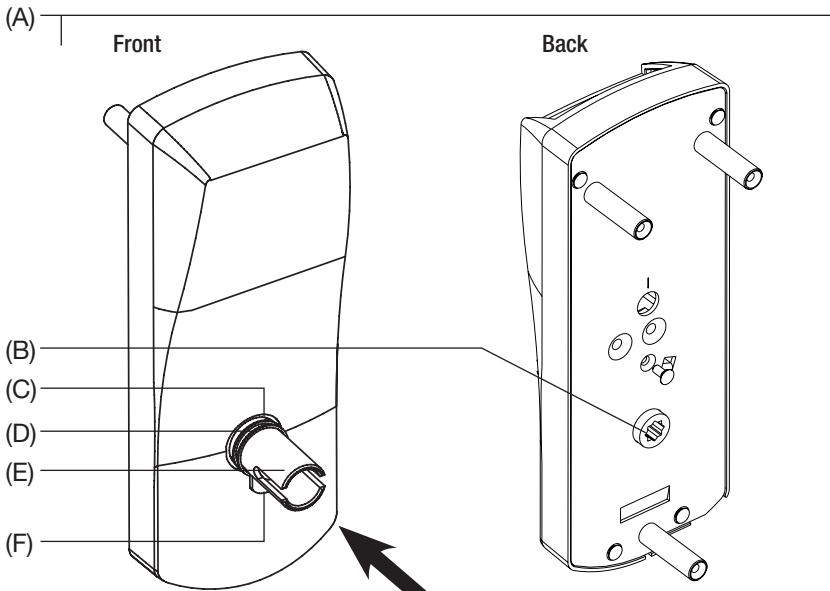
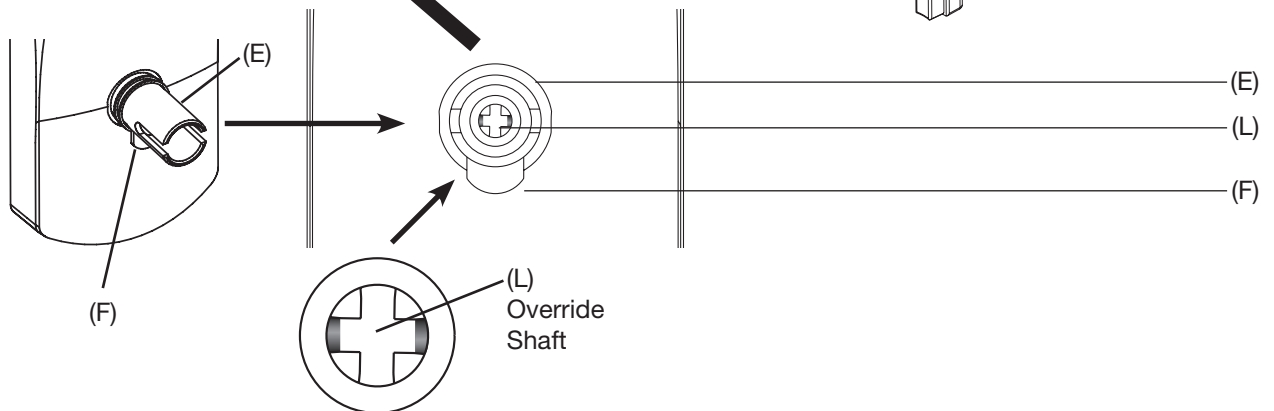

Diagram of lock:

- | | | |
|----------------------|------------------|--------------------|
| (A) Lock housing | (E) Drive tube | (I) Cap |
| (B) Inside drive hub | (F) Lever catch | (J) Cylinder |
| (C) Nylon washer | (G) Countersink | (K) Cylinder plug |
| (D) Spring washer | (H) Lever handle | (L) Override shaft |



Facing view of drive tube: (E)



1. Upon unpacking, lock housing with mechanical override should look like the diagram below with:

- (M) The small indents on the cross of the override shaft in line Horizontally
- (C) The nylon washer and the spring washer on the drive tube
- (F) The lever catch in the out position
- (J) Cylinder and 2 keys for 79M keyed different only included in the hardware bag

i Important: Assemble the lever, cylinder and lock components before affixing the entire unit to the door.

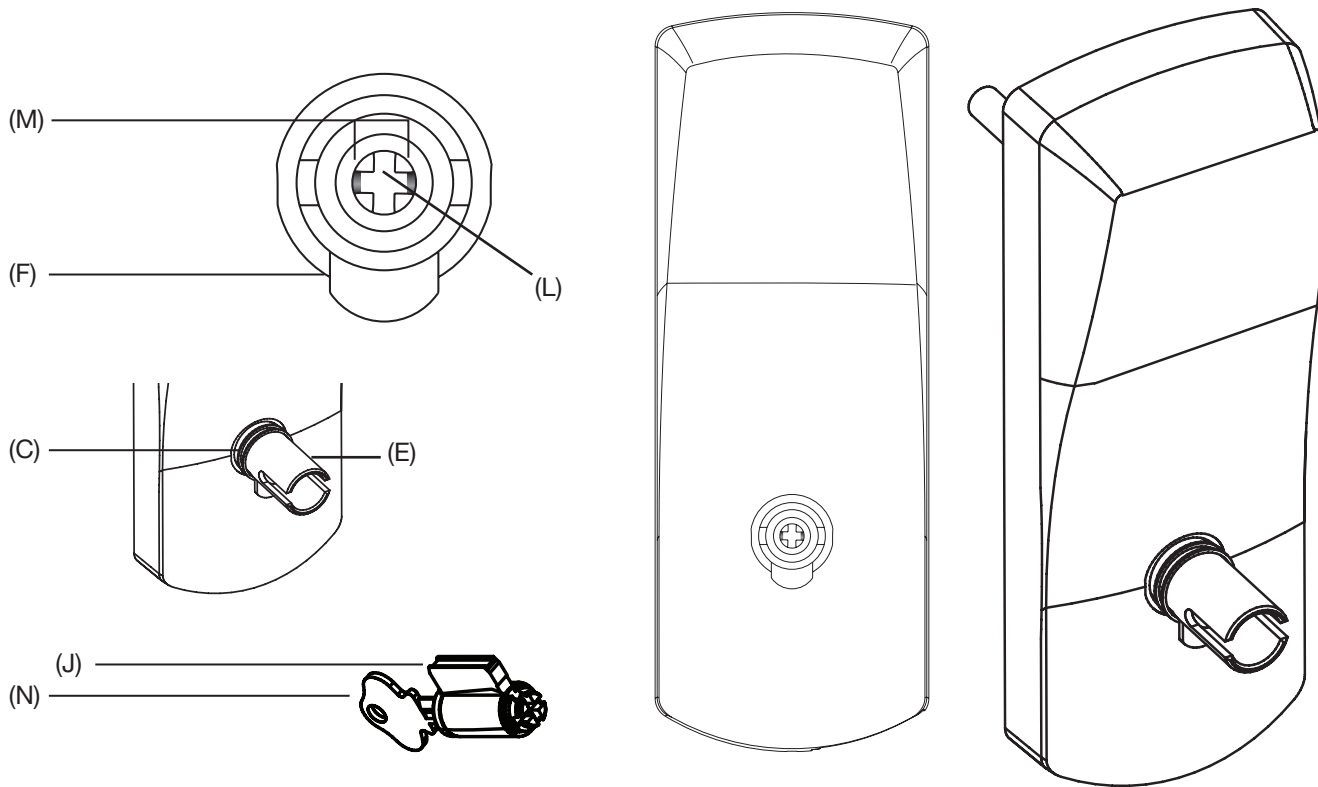

2. Preparing the outside housing for the installation of the lever handle

1. Insert the cylinder (J) to be used as a tool or equivalent tool to rotate the override shaft (L) and turn it clockwise until it stops so that the two small indents (M) on the cross are now vertically in line. (Fig.1)

2. Push in the lever catch (F) firmly. (see Fig. 2) to be flush with drive tube diameter

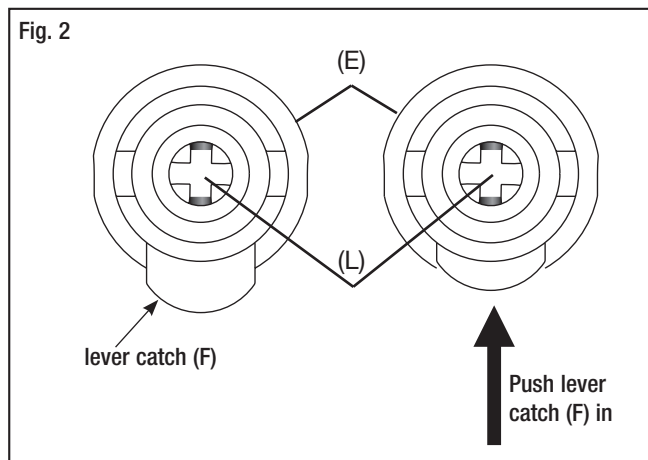
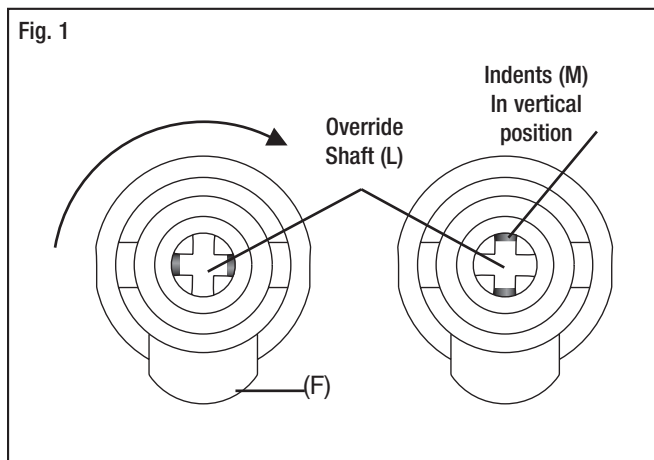

3. Preparing the lever handle and cylinder for installation

NOTE: For locks with Best Removable core, skip steps a,b & c below. Assemble Best core and adaptors as per instructions F5, F6 & F7 on page 21. Then follow step 4 of this page. Step to attach the lever handle to the lock housing.

a. Insert the cylinder (J) without key (N) into the lever handle (H) (see Fig.3)

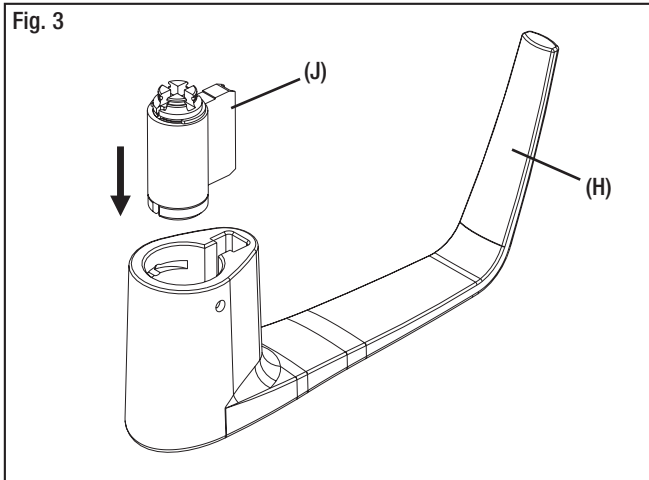

b. Put the cylinder plug (K) into the lever (H) (see Fig.4)

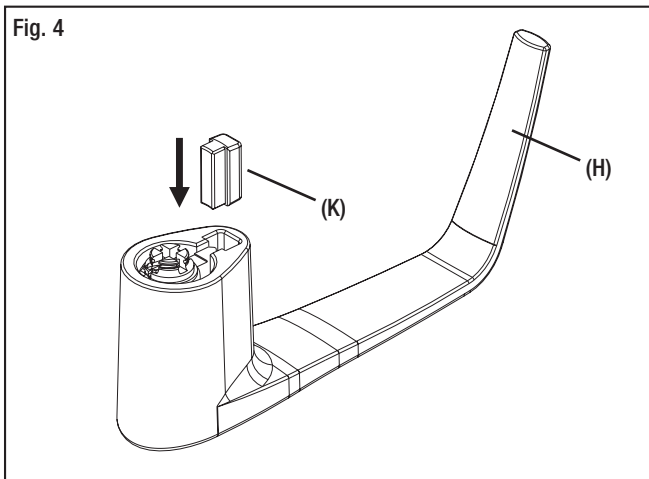

c. Insert key (N) into cylinder (J). Hold plug (K) in position. (See Fig. 5).

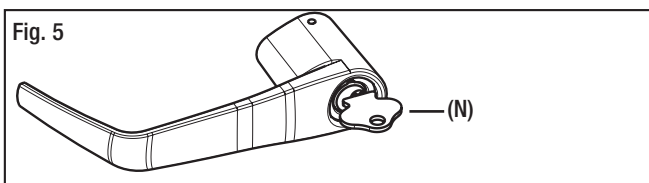

Caution: If the Lever is Not Assembled with the key in the position shown in Fig. 6 & Fig. 7, the inside mechanism of the lock could be damaged if the lever is rotated and forced.

4. Steps to attach the lever handle to the lock housing

***NOTE:** the position of the key is very important

Right-handed Lever handle: Turn the key (N) approximately to 100° clockwise so that it is in the vertical position and the recess entry for key is in the top position. (See Fig. 6)

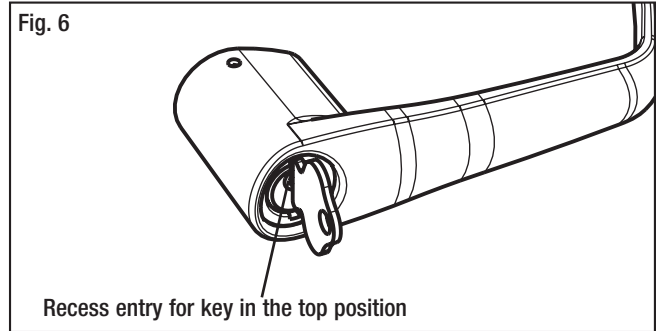

Left-handed lever handle: Turn the key (N) approximately to 100° clockwise so that it is in the vertical position and the recess entry for key is in the bottom position. (See Fig. 7)

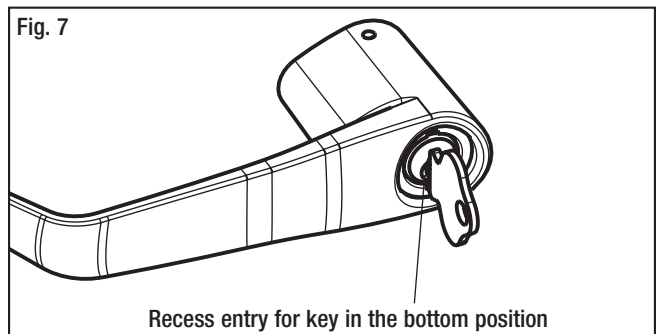

! The key (N) and the recess entry for key must be in the positions shown in Figs 6 & 7 before placing the lever handle on the housing or the lever and the override mechanism will not work.

Troubleshooting:

If you have assembled the lever and housing with the key (N) in the wrong position, the key (N) will get stuck. To remove the key (N), turn it so that it is in the vertical position and insert a small flat screwdriver (T) (see page 15) into the hole under the lever handle to push Lever Catch (F) in (see page 16 Fig.2). Remove lever, remove key. If it is still stuck, turn the key 90° clockwise to the horizontal position and push the Lever Catch (F) in again with the small screwdriver (T). Remove key (N).

5. Attaching the Lever Handle to the Lock (with the key as shown in Fig. 6 & Fig. 7)

7. Fit the lever handle (H) onto the drive tube (E) see page 15. It should rest approximately 1/16" from the body of the housing. If not, wiggle and jiggle key (N) to align cylinder (J) with override shaft (L)(See Fig. 8)

If it can't be pushed that close to the housing, the lever catch (F) is probably not pushed in. Push it in. (see fig 2 page 16)

If the lever catch (F) is stuck, the override shaft (L) is in the wrong position. (see fig 2 page 16) The two small indents (M) on the cross of the override shaft (L) must be vertically aligned as in fig 2 page 16

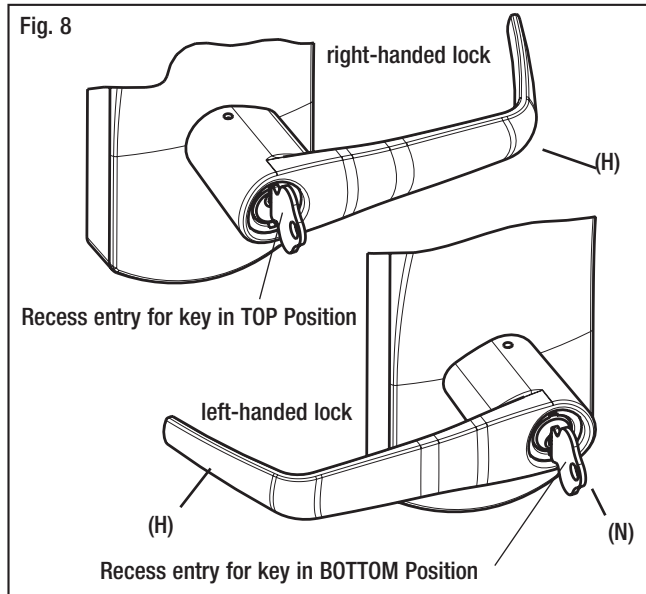

8. Press the lever (H) firmly against the housing while turning the key (N) counterclockwise (**this applies to both right-handed and left-handed locks**) until it is in the horizontal position. (Fig. 9)

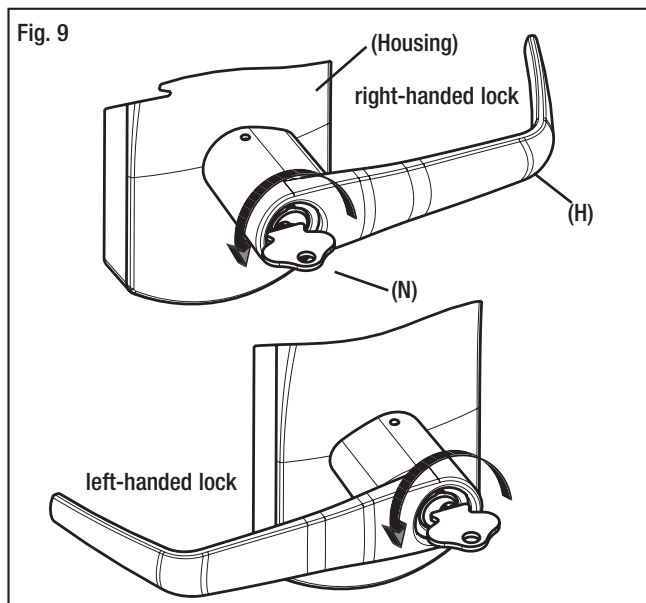

If it is not possible to turn the key (N) counter-clockwise to complete this step, the spring washer (D, see page 15) may be too tense:

Hit the lever carefully with a rubber mallet to loosen the spring washer (D). (you may want to cover the lever handle (H) with a cloth or other material to protect the finish of the metal)

9. Remove the key (N). The lock will look as shown in Fig.10.

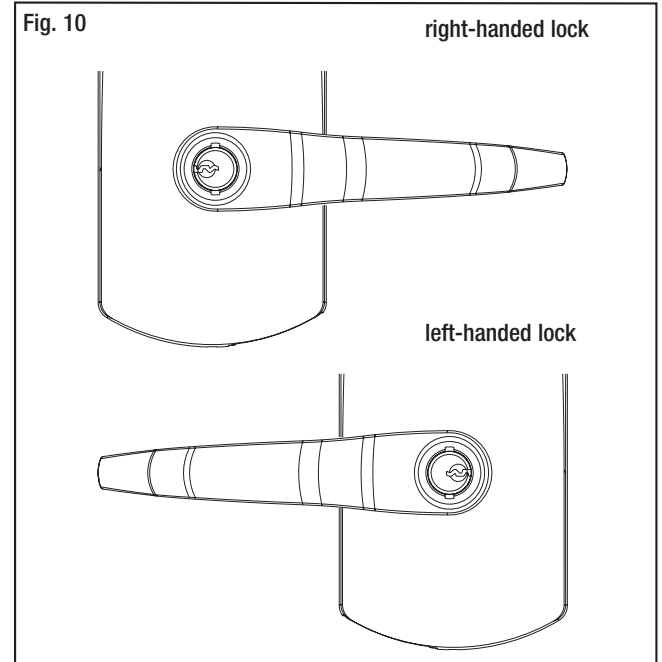

Gently check the rotation of the lever handle (H). It should easily rotate approximately 45°.

Troubleshooting:

Right-handed Lock: Turn the lever handle (H) clockwise without forcing it. If it stops at approximately 15°, it was not assembled correctly as shown in step 4 (Fig. 6 & 7). **Do not try to force it to turn.** Release the lever handle (H). Insert the small screwdriver (T, page 15) into the small hole on the underside of the lever handle (H) and push in the lever catch (F) see page 16 fig.2. Re-do steps 2, 3, 4 & 5.

Left-handed Lock: Turn the lever handle (H) counter-clockwise without forcing. The drive hub (B) (Fig.12 page 19) should not rotate when the lever handle (H) is turned. If it does, it was not assembled correctly as shown in step 4 (Fig. 6 & 7). Release the lever handle (H). Insert the small screwdriver (T, page 15) into the small hole on the underside of the lever handle (H) and push in the lever catch (F). Re-do steps 2, 3, 4 & 5.

6. Verify the attachment of the lever handle



Very Important: To verify that the lever handle has been correctly attached to the housing:

10. Remove key (N)
11. Insert a small flat screwdriver (tool T, page 15) into the hole on the underside of the lever handle (H) and push in the lever catch (F) see fig 10A.
12. Pull on the lever handle (H).

You should not be able to remove the lever handle (H). If it comes off of the housing, you did not assemble the lock correctly. Return to steps 2, 3, 4 & 5 and make sure that the lever (H) looks like Fig. 10 page 18 and repeat this verification process. (Step 6)

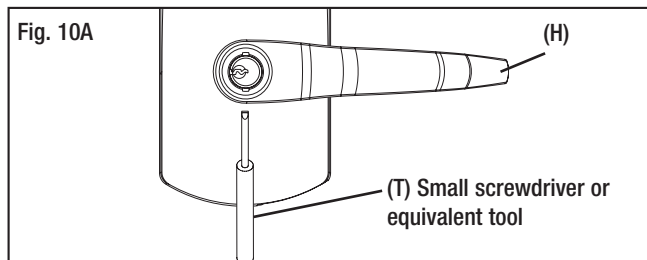

7. Test the movement of the lever handle (remove the key (N) in cylinder (J))

13. Turn the handle (H) clockwise (for a right-handed lock) or counter-clockwise (for a left-handed lock)
14. Release the handle (H) slowly. It should return freely to its horizontal position. (Fig.11)
15. If the handle (H) doesn't easily return to its original position, the spring washer (D) (page 15) is probably too tight. Use a rubber mallet to hit the lever (H) carefully against the housing to reduce the tension of the spring washer (D), until the handle (H) moves freely back to its horizontal position when turned slowly.

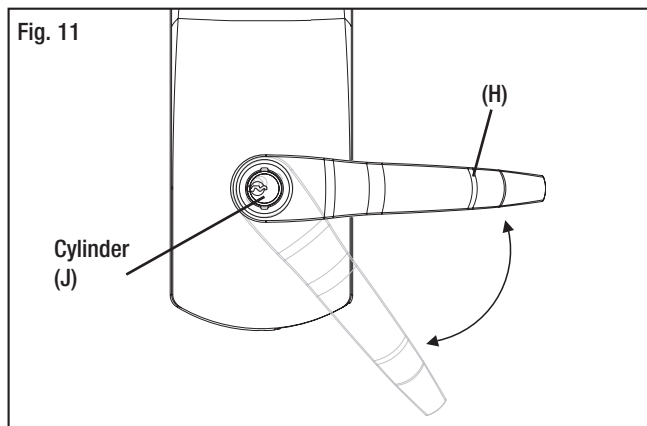

8. Test the mechanical override function (Complete all tests in Section 4, pages 12 & 13 after lock is assembled on the door)



* This test can only be performed when the lock is not affixed to the door.

16. Without using the key (N), turn the lever handle (H) clockwise (for Right-handed locks) or counter-clockwise (for Left-handed locks). The inside drive hub (B) should not rotate when the handle (H) turns. (Fig. 12)

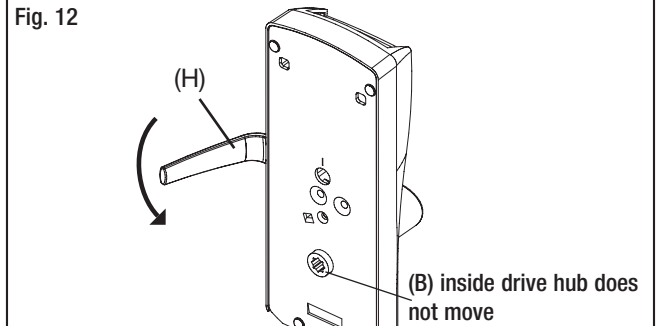

17. With the lever handle (H) in the horizontal position, insert the key (N) into the cylinder (J) and turn it clockwise **until it stops**. (This applies to both Right and Left-handed locks, see Fig.13)

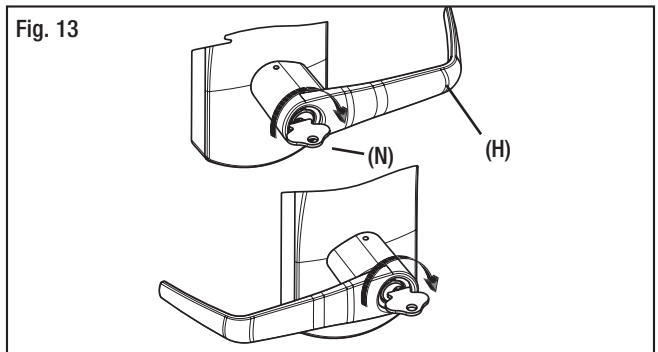

18. Let go of the key (N), and again turn the lever handle (H) clockwise (for Right-handed locks) or counter-clockwise (for Left-handed locks). Now the inside drive hub (B) should rotate in the same direction as the lever handle (H) when it is turned. (Fig. 14)

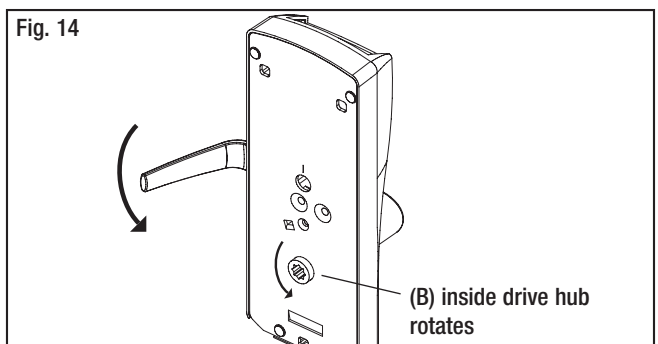

Test the Mechanical Override Function (continued)



Verify the functionality of the override after the lock is installed on the door: (Door must be opened)

19. With the door open, insert key (N) in cylinder (J) and turn it clockwise **until it stops**.

20. Let go of the key (N) and turn the lever handle (H) (clockwise for right-handed and counter-clockwise for left-handed locks). **The latch must retract**.

21. Extend deadbolt and repeat the above operation (turn key (N) clockwise until it stops), latch and deadbolt must retract completely.

9. cover the keyhole & cylinder with the cap

22. The cap (I) has a small groove on one edge (to allow ease of removal) this should be facing down. Insert bottom snap of cap (I), (see Fig. 15) in handle hole below the cylinder (J). With a small screwdriver, push top snap of cap down while pushing the cap (I) into place to cover the keyhole (Fig. 15)

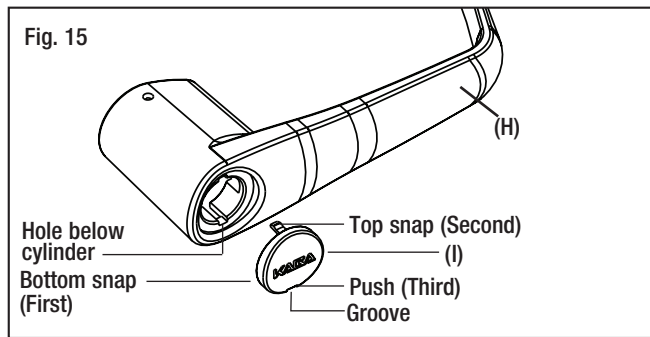

23. To remove the cap (I), insert a small flat screwdriver into the groove and gently pry the cap off, being careful not to damage it. (You may want to cover the bottom of the lever to protect the finish from being scratched through the process of removing the cap). (Fig.16)

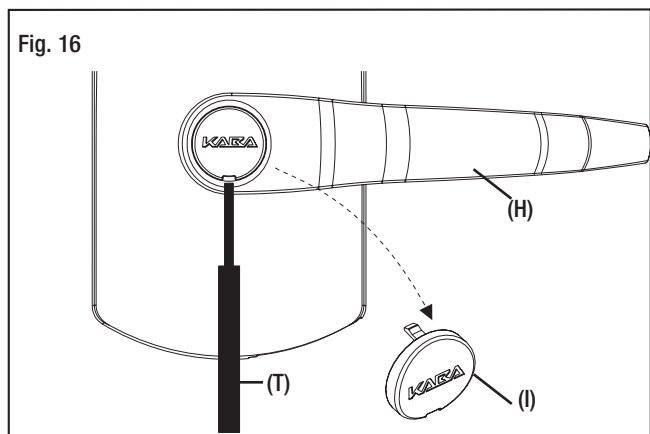

10. How to change lock cylinders

24. Remove the cap (I) from the lever handle (H) (see step 23, Fig. 16).

25. Insert key (N).

26. Turn the key (N) clockwise until it stops.

27. Release key (N).

28. Use a small flat screwdriver to push in the lever catch (F) through the small hole underneath the lever handle (H) (Fig. 17).

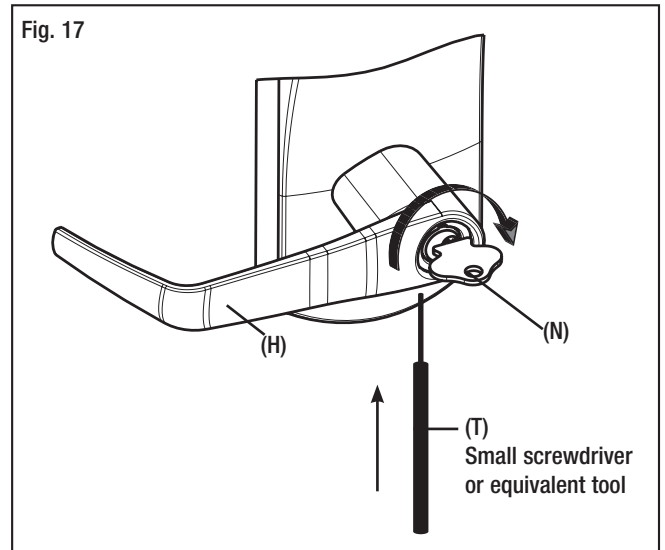

29. Pull the lever handle (H) off of the lock housing (be careful not to lose the cylinder plug (K) see page 15).

30. Replace the old cylinder with the new one in the lever handle (H). Only same kind of cylinder with 2 grooves in cross, in the end of the cylinder plug could be used on the locks. (Fig. 18)

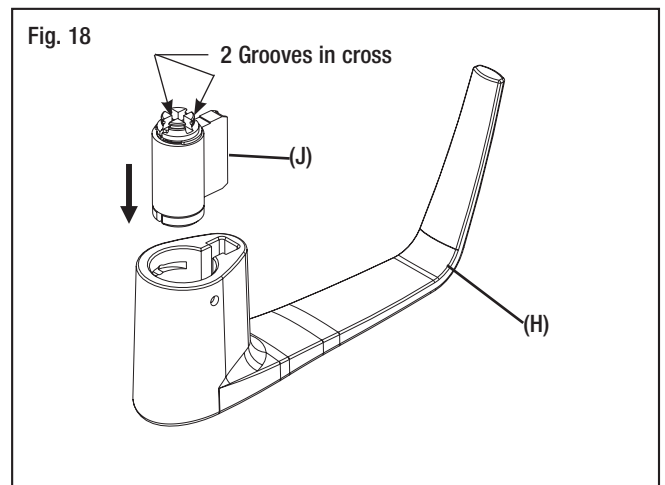

How to change lock cylinders (continued)

31. Re-insert the cylinder plug (K) (Fig. 19)

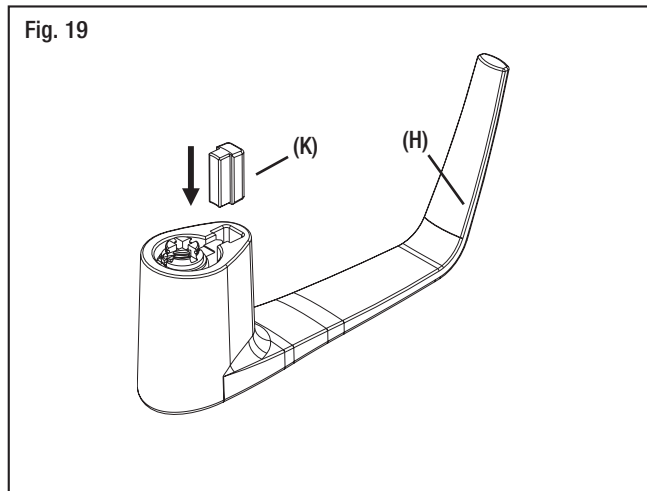

32. While holding the cylinder (J) and plug (K) in place, insert the key (N)

33. Turn the key (N) approximately 100° clockwise

34. Repeat the steps 1 to 9 to attach the lever handle (H) to the lock housing. (see Fig. 20)

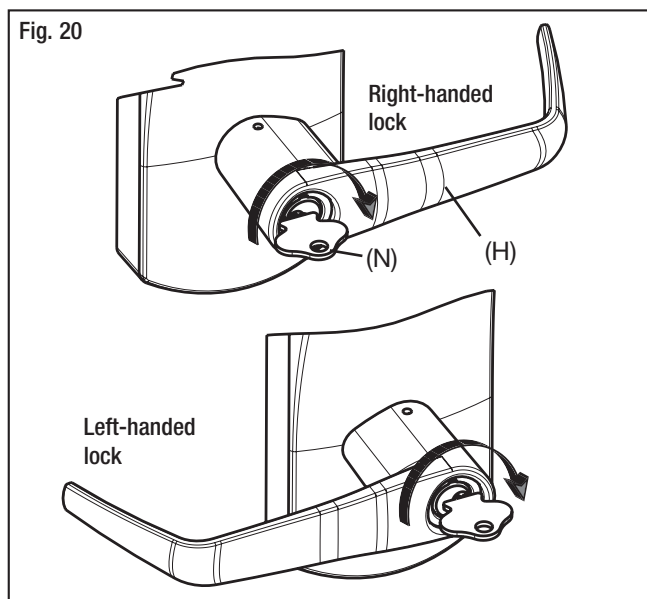

Important: The Key Override itself does not retract the latch or deadbolt. Do not use too much force when turning the key as this may damage the unit. To retract the latch, turn the key clockwise until it stops, release the key and turn the lever handle (H). See page 19



Note: The lever handle must stay in the horizontal position when turning the key (do not try to turn the key while turning the handle) or the override mechanism will not work.



Important: Always keep the door open while installing and verifying the functionality of the 79 Series lock with the keycard or key override. Do not close the door until you are certain that you have installed the unit correctly.

Preparing the lever handle for Best Removable Core

F-5 Insert 6-pin Best adapter (thicker) into 6-pin interchangeable core or insert 7-pin Best adapter (thinner) into 7-pin interchangeable core. Insert the adapter until it makes contact with the removable core.

F-6 Using the control key, assemble the removable core with its adapter into the lever. Remove control key.

F-7 Insert the change key into the removable core.

Follow the rest of instructions from step 3.C of page 17

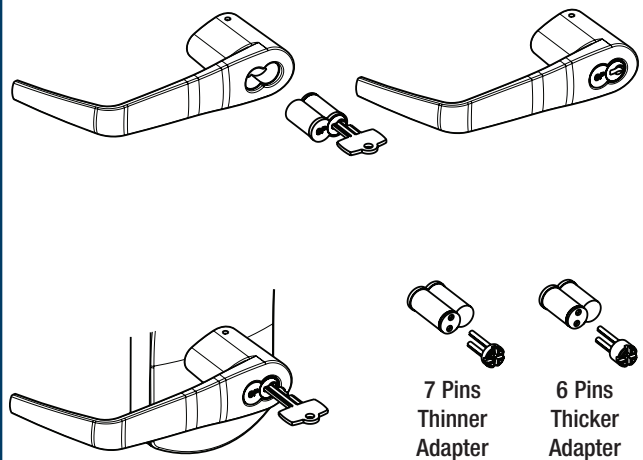

11. The Recodable Cylinder with 3 different keys



Important: Read the following instructions before using any of the 3 keys supplied

The 79M with a recodable cylinder can be operated with three different keys. The keys are numbered 1, 2 & 3, and each key is labeled and supplied in a separate plastic bag. It is very important to use them in order.

*** Always read the label instructions on the label before using a key.**

Caution: The use of key #2 automatically cancels the function of key #1, and the use of key #3 automatically cancels both keys #1 and #2.

If key #3 is used first, it will immediately make keys #1 and #2 unusable.

Once a key is cancelled, it can't be reactivated unless the cylinder itself is re-pinned.

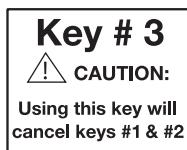
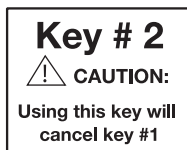
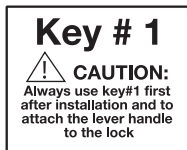
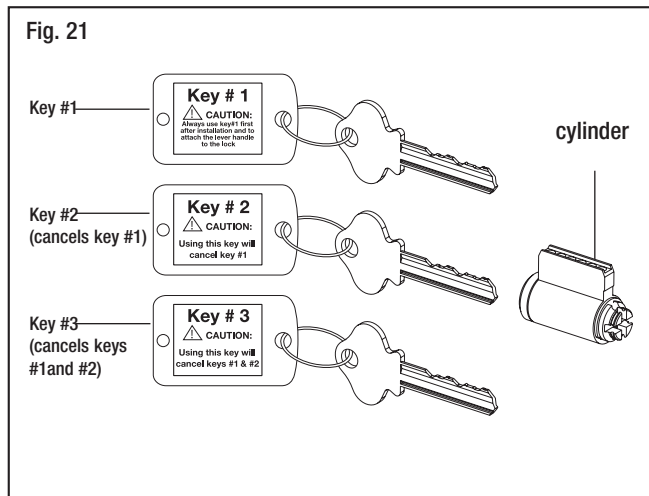

How to change lock combination from key #1 to key #2:

35. Insert key #2 into cylinder.

36. Turn the key clockwise until it stops (see Fig. 22) for both left-handed and right-handed locks.

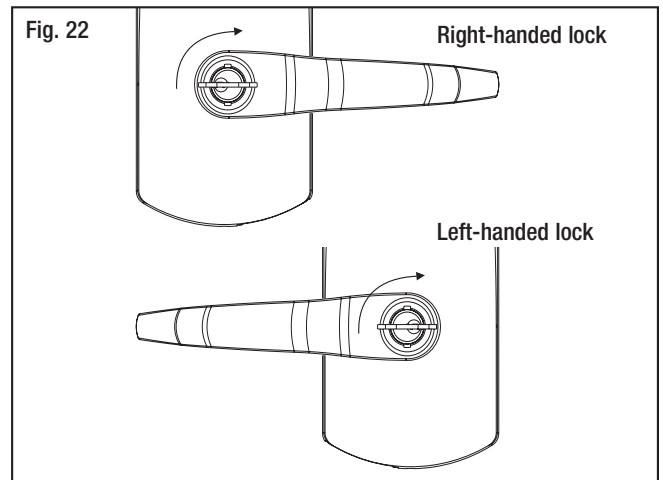

37. Turn the key back counter-clockwise until it is in the horizontal position.

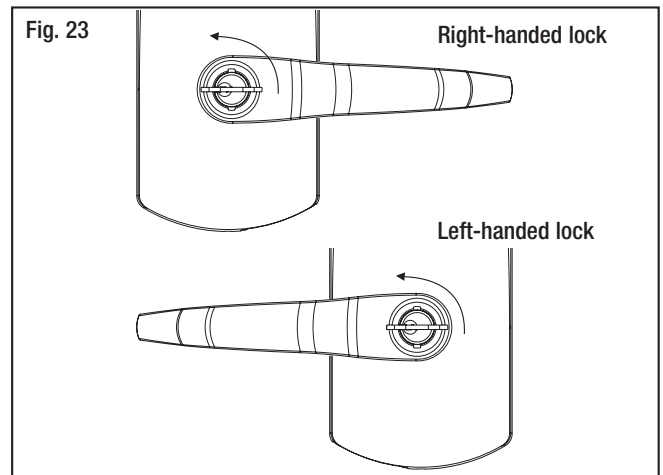

38. Remove the key.

Now the lock should work with key #2, and key #1 has been cancelled.

**Test: Try to use key #1 in the lock. It should no longer work.*

How to change lock combination from key #2 to key #3

39. Insert key #3 into cylinder.

40. Turn the key clockwise until it stops.

41. Turn the key back counter-clockwise until it is in the horizontal position.

42. Remove the key.

Now the lock should work with key #3, and key #2 has been cancelled.

**Test: Try to use key #2 in the lock. It should no longer work.*

APPENDIX A.1 • Reversing the Mortise Handing

A.1.1 Reversible ASM

1. Remove the mortise faceplate. Remove screw (V) and lock washer (W) if applicable and **place the mortise on a flat surface for the following steps.**

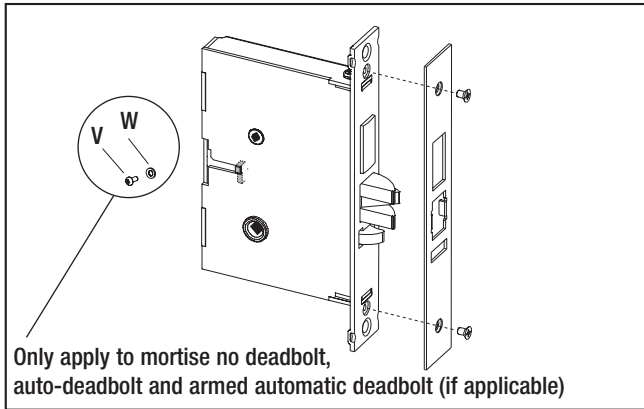

2. Partially extend the deadbolt:

For normal ASM, rotate hub (H) using a screwdriver, until the deadbolt (D) extends approximately 1/4".

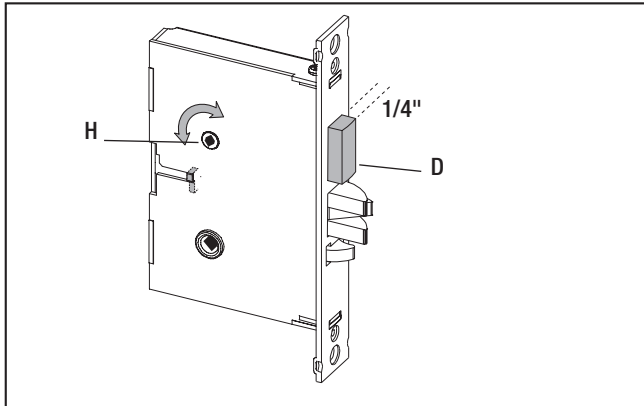

Proceed to step 3.

For Autodeadbolt ASM, rotate hub (H) until the deadbolt (D) is fully retracted. The deadbolt will extend approx. 1/16" from the mortise case.

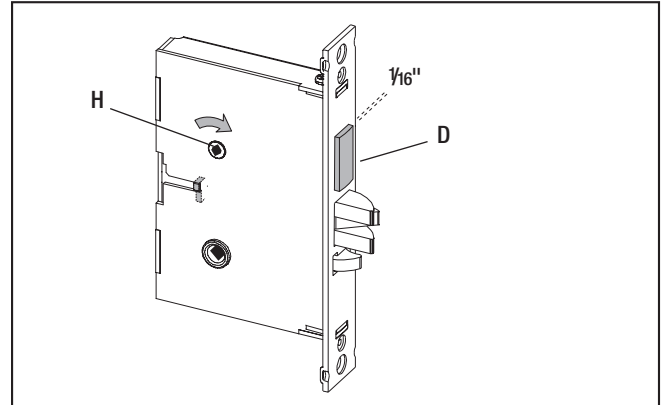

Hold deadbolt (D) gently. Press and release the auxiliary latch (X). You should feel the deadbolt trigger and begin to extend under the force of the spring.

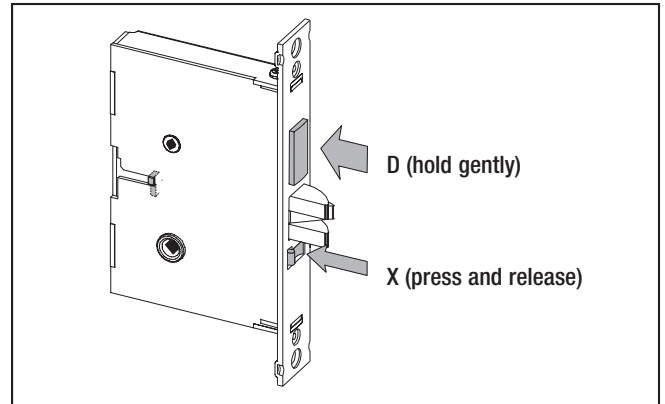

Release the deadbolt (D) gently. It should extend to 5/16" approx. and stop. If the deadbolt extends past this point, gently press it in until it locks at 5/16" throw, or start step 2 again.

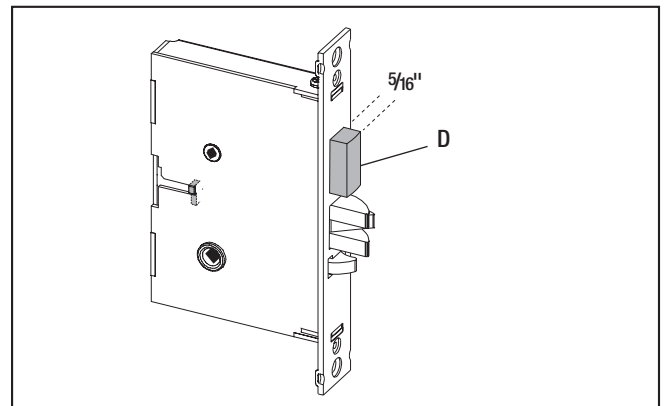

A.1.1 Reversible ASM (continued)

3. Push in the latch bolt (L) to the middle of its stroke, and hold it there. (Continue Step 1 and 2)

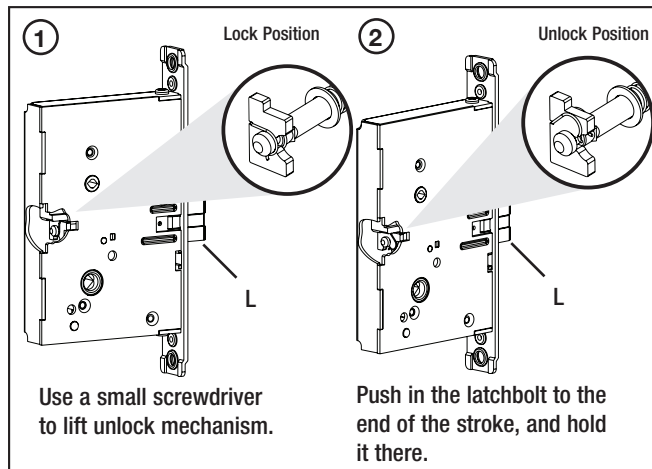

Hold the latch (L) inside the mortise, and insert the tailpiece retaining tool (S, part #027-510382 available separately) so that the tailpiece (T) will not drop inside the mortise case. Hold the tool and the latch with one hand, and slide up the tailpiece using a small screwdriver.

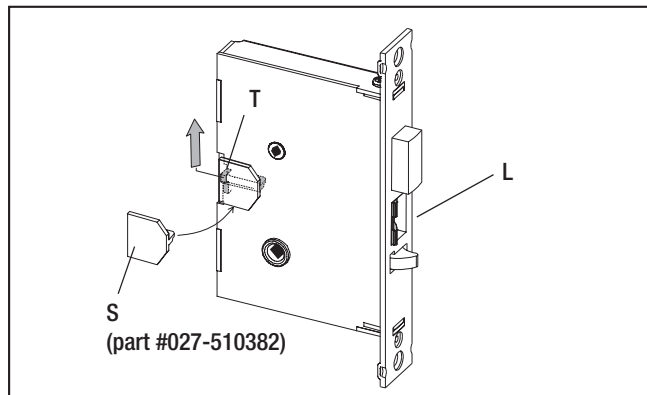

Continue to hold tool (S). Release the latch bolt (L) and keep the anti-friction latch (F) toward the flat side of the latch bolt so that the bolt extends fully.

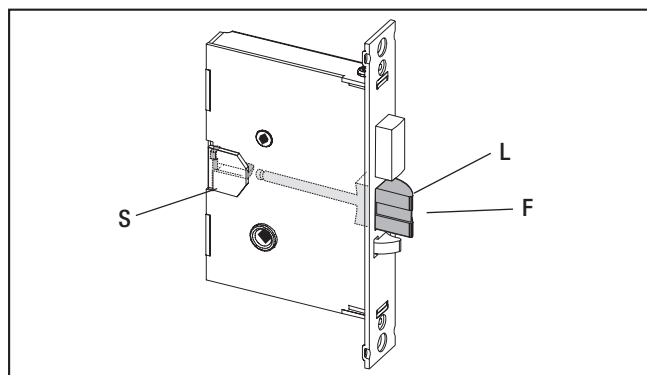

4. Pull out the latch bolt (L), until it just clears the front plate. (Note: If you remove the bolt completely, you must turn it 90° to re-insert it.)

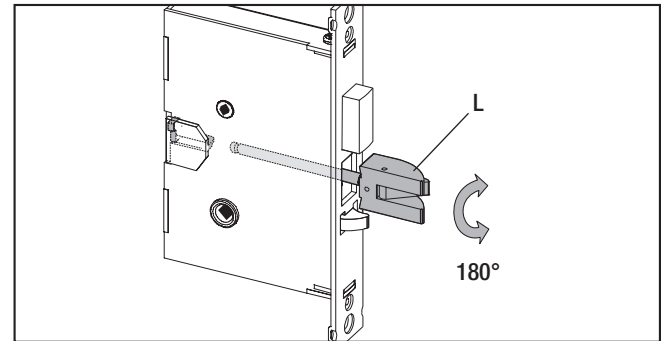

Rotate the latch bolt (L) 180°. Re-insert it to the end of its stroke.

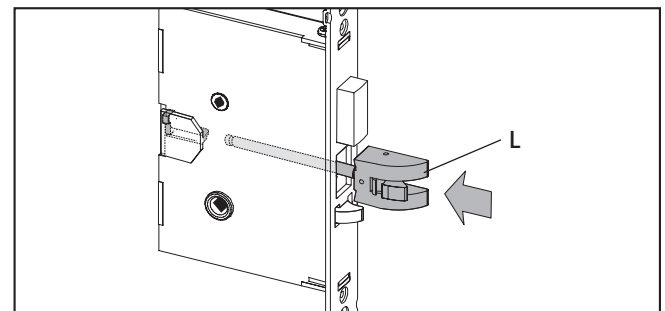

Holding tool (S) in place, re-engage tailpiece (T) with latch bolt (L) (slide tailpiece down). There may be some play required to align the parts. Remove the tool (S).

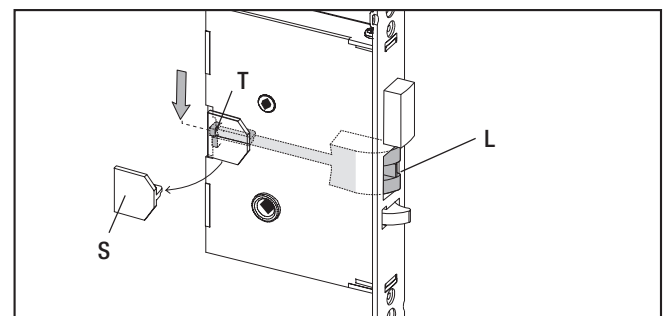

Release the latch to the middle of the stroke and hold it there. Use a small screwdriver to push the lock mechanism back on lock position (see step 1 and 2).

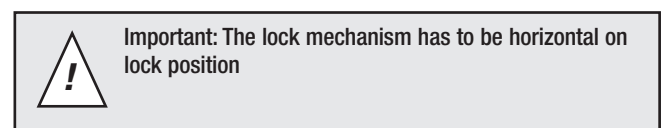

5. Release the latch bolt (L). Position the latch bolt so that the bottom tooth of the anti-friction latch (F) remains inside the mortise case as shown.

 If the tooth of (F) is outside the mortise, you will not be able to re-assemble the faceplate on the mortise.

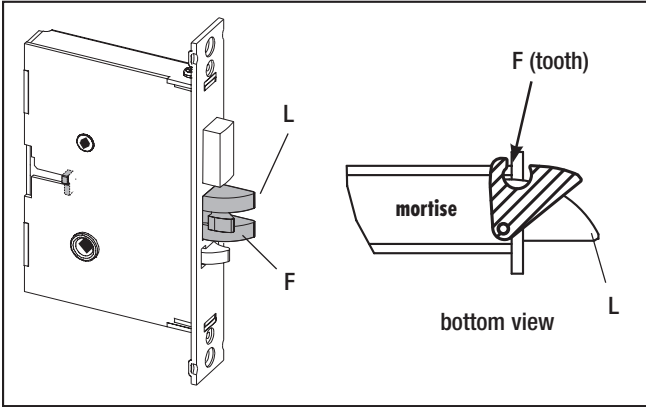

6. If the auxiliary latch (X) is shaped like a triangle, there is no need to change its handing.

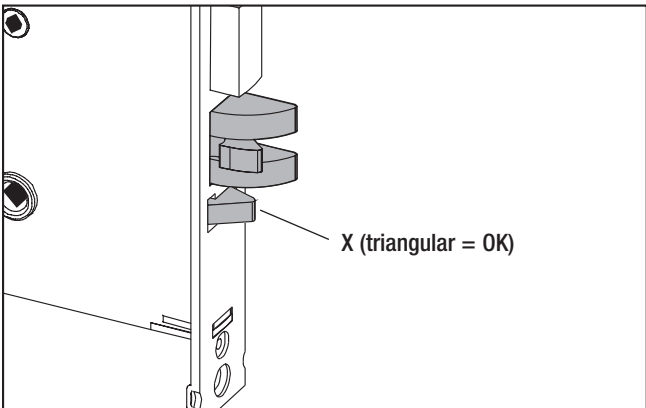

If the auxiliary latch (X) is a crescent shape, remove it, turn it 180°, and replace it. The auxiliary latch slides easily in and out of the mortise.

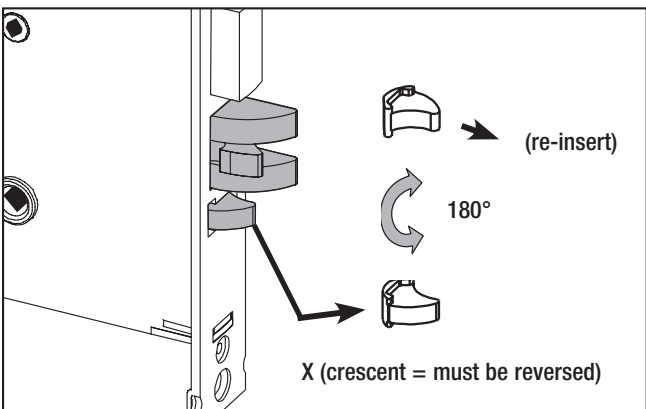

7. Assemble back screw (V) and lock washer (W) if applicable. The screw (V) must be tightened.

IMPORTANT: Screw (V) must not touch the back wall of mortise cut-out on the door

8. The mortise should look like the diagram below. (Check the orientation of the latch bolt and auxiliary latch.) Check the bevel of the mortise and change it if required as described in section 3.3, paragraph 6 page 9.

ASM

For LH (left hand) and RHR (right hand reverse)

Only apply to mortise no deadbolt, auto-deadbolt and armed automatic deadbolt

For RH (right hand) and LHR (left hand reverse)

A.1.2 Reversible ESM

1. Remove the mortise faceplate, and place the mortise on a flat surface for the following steps.

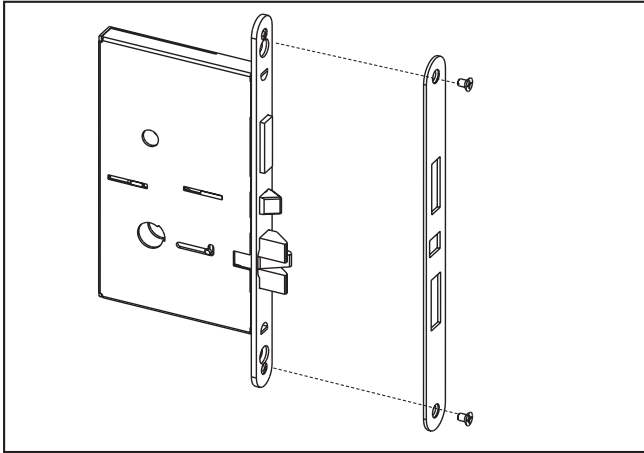

2. Retract deadbolt (D) as shown by turning the hub (H) with a small screwdriver, then push in the latch bolt (L) to the end of its stroke.

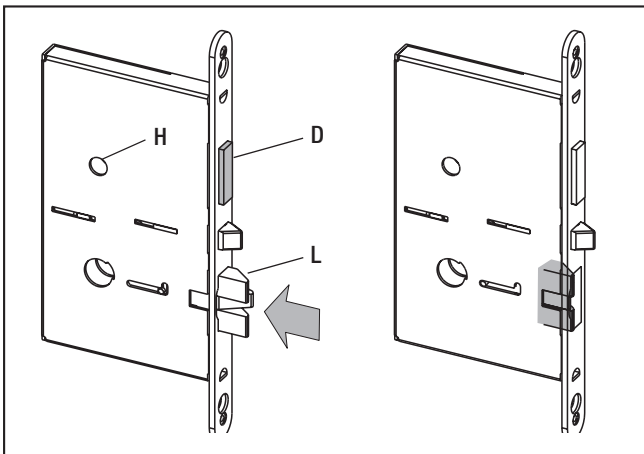

Release the latch bolt, and guide anti-friction latch (F) against the flat side of the latch bolt so that it will slide out of the mortise beyond its normal throw.

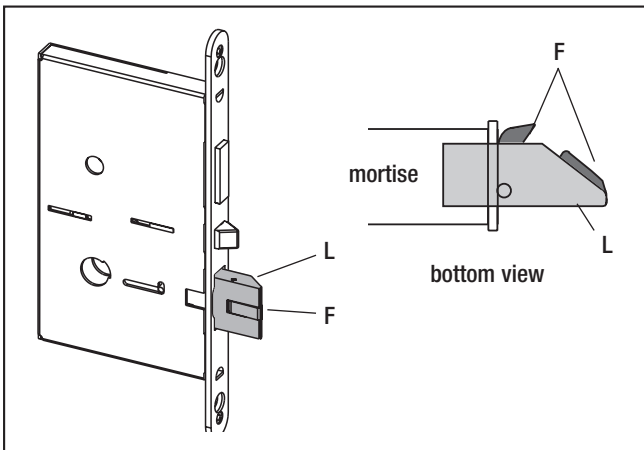

3. Using a small screwdriver, slide up the locking pin (P). Pull out the latch bolt (L) and rotate it 180°.

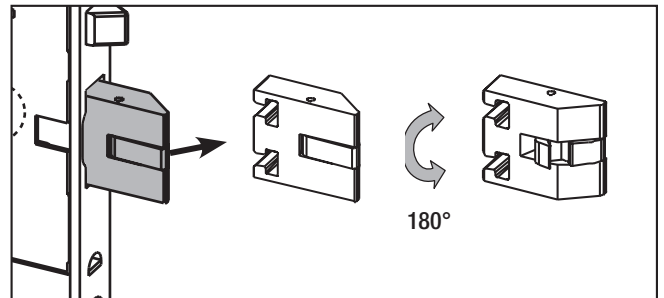
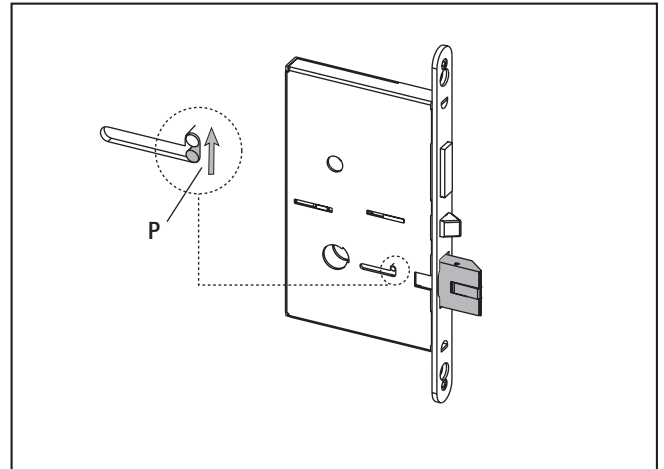

4. Re-insert the rotated latch bolt (L) until it stops. Push down pin (P) to lock the latch bolt in the mortise.

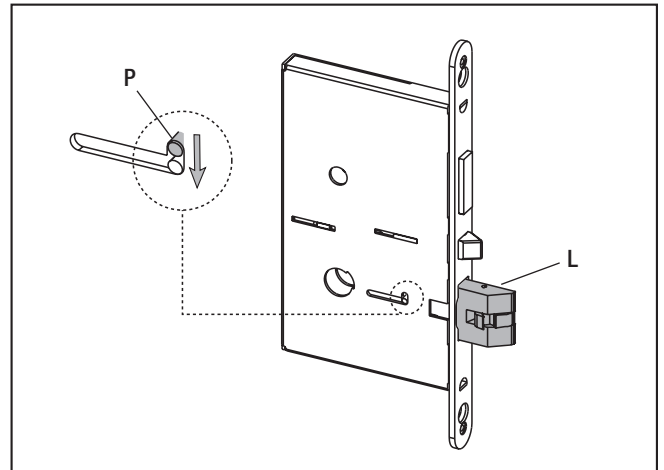

5. Push in the latch bolt (L) to the end of its stroke.

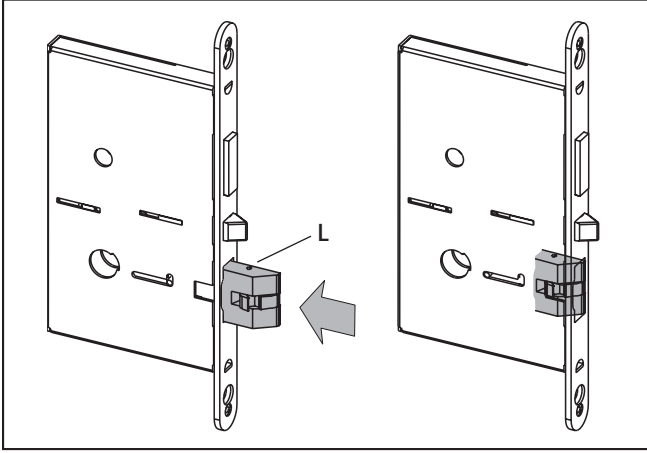

Release the latch bolt (L) while positioning anti-friction latch (F) so that it will remain inside the mortise. Ensure the bottom tooth of the anti-friction latch (F) remains inside the mortise case as shown.

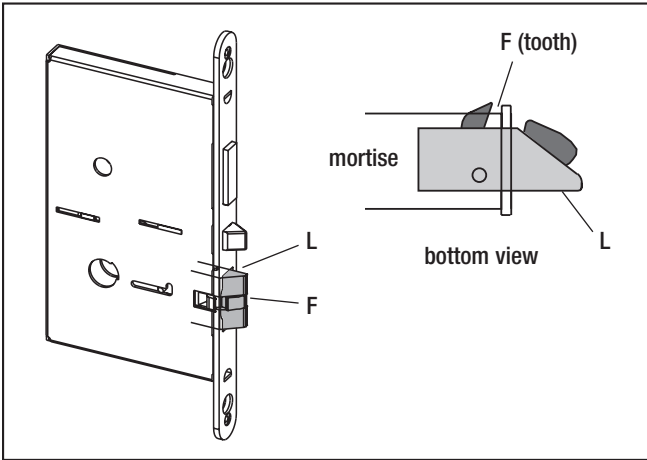

If the bottom tooth of (F) is outside the mortise, you will NOT be able to re-assemble the faceplate on the mortise.

APPENDIX A.2 • Additional steps for Autodeadbolt ASM for 79M Standard mode only

Do the following **INSTEAD OF** page 10, step 5:

A. 2.1 79M Standard mode inside trim assembly for ASM. See E on page 4

A. 2.2 79T Toggle mode inside trim assembly, for cylindrical; autodeadbolt and ASM. See page 6

A. 2.3 79M Standard mode autodeadbolt inside trim assembly. If not already installed at the factory, put the thumbturn in the vertical position and install all four parts (M) as shown on the inside trim assembly.

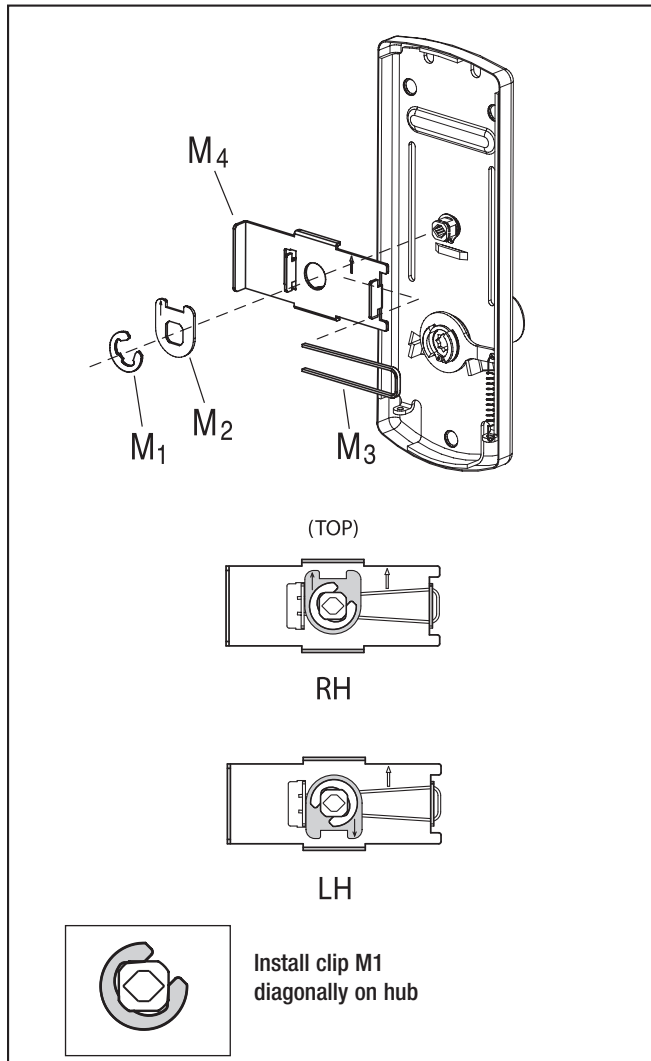

The thumbturn has to be in the vertical position as shown in Fig. A.2.3. For Right Hand installation, the arrow of M2 points UP. For a Left Hand installation the arrow of stopper M2 points down.

Place 3 spacers (S) on the door (for recent models only). For 79T Toggle mode, connect switch cable (W2) to outside housing cable (W1). Place the inside trim assembly with thumbturn "T" in position shown below, on the door so that the upper and lower spindles (F) and (G) engage the thumbturn and the inside lever. For 79T Toggle mode, push the 2 connectors & the maximum of their cable in hole (H1). Fasten to the outside housing using the three 1/8" hex head mounting screws (I).

Apply the privacy thumbturn sticker as shown. If in doubt as to the direction of the arrow, press the auxiliary latch (X) to extend the deadbolt, and verify in which direction to rotate the thumbturn to reach the horizontal (privacy) position.

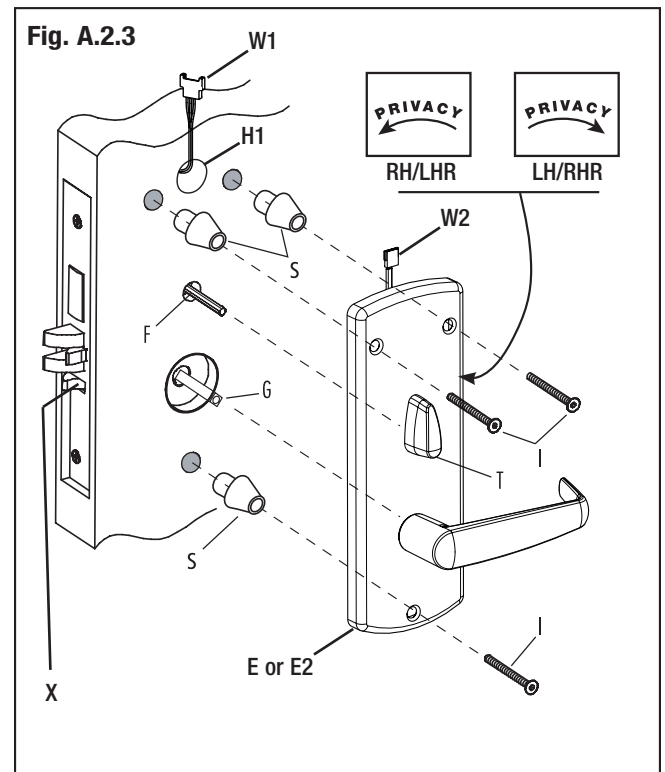

APPENDIX A.3 • Additional steps for ASM Office for 79M Standard mode Only

Do the following **BEFORE** placing the inside trim assembly on the door (page 9, step 5):

Install only parts (M3 and M4) as shown, on the inside trim assembly.

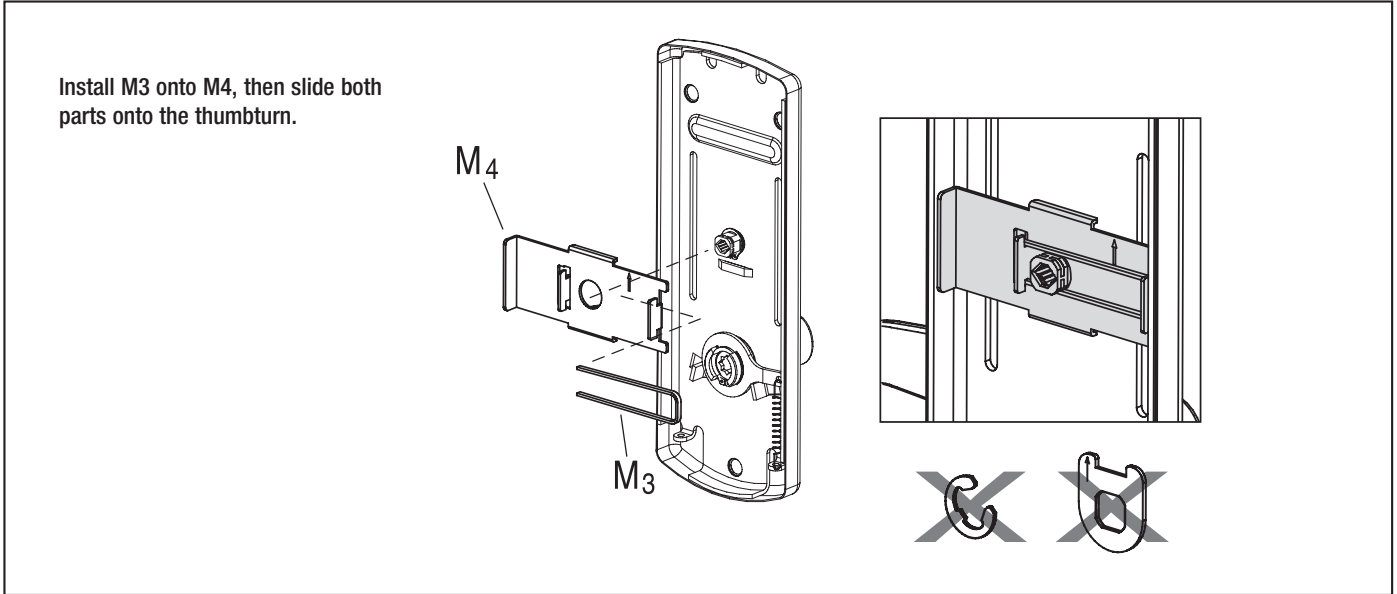

APPENDIX A.4 • Additional steps for ASM/ESM STOREROOM for 79M Standard mode Only

Do the following **BEFORE** placing the inside trim assembly on the door (page 8, step 5):

Put the thumbturn in the vertical position and install only parts (M2 and M4) as shown, on the inside trim assembly. The notch on the stopper cam (M2) must engage the tab on the plate (M4), so that the thumbturn is locked in the vertical position.

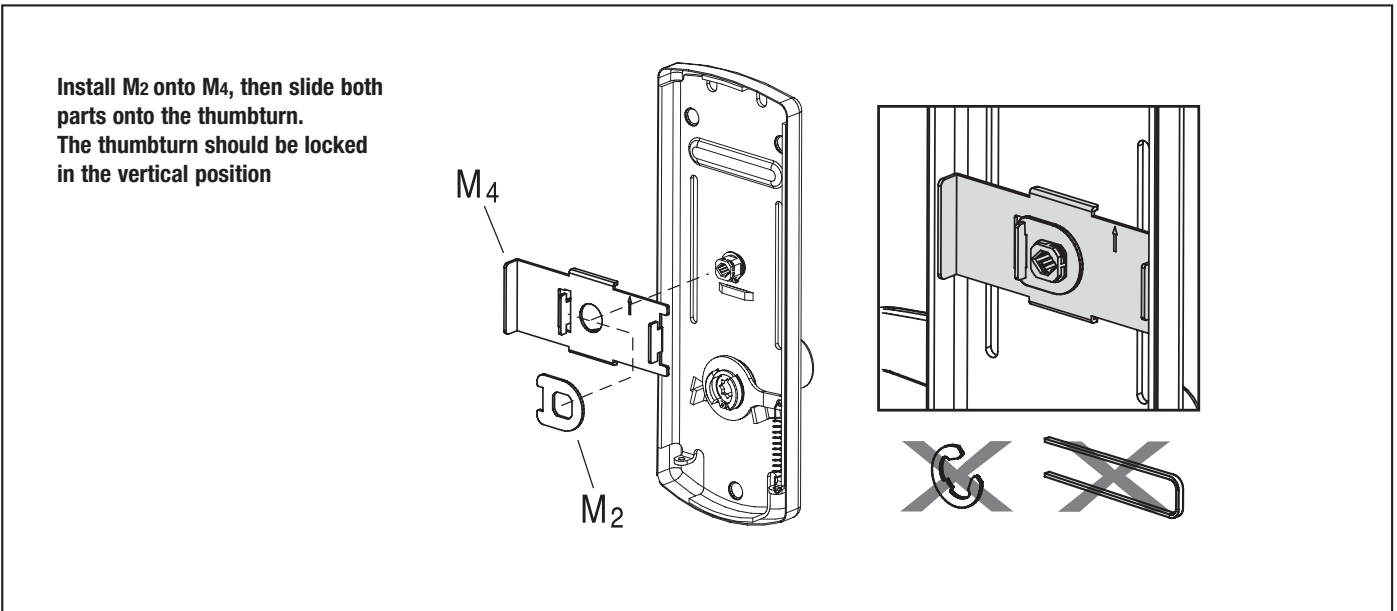

APPENDIX B • Installing Cylindrical Models 2³/₈" & 2³/₄" Backset

B.1 Install the Strike

Follow the same steps as for a mortise model strike (see page 8, all steps in section 3.2). Note that the handle height is aligned with the center of the strike.



For cylindrical latch models, ensure the dead-locking pin will stop against the strike when the door is closed (see figure). An incorrect installation that permits the pin to slip inside the strike may result in a total lockout and will void the warranty of the complete lock mechanism.

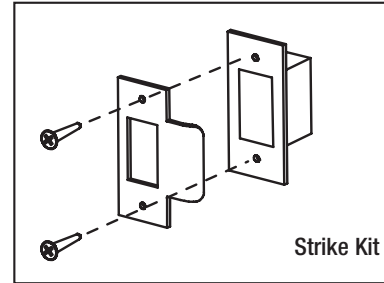

Strike Kit

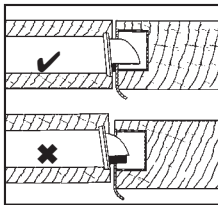

Correct

Incorrect

B.2 Install the Latch

Follow the instructions on page 9, steps 1 to 3.

Note that for cylindrical models, the axis of rotation of the handle is level with the center of the strike. Mark this height on the edge of the door in step 1 on page 9.



Respect applicable building codes regarding handle height.

4. Drill the holes for the cylindrical unit, thumbturn spindle, and lock mounting screws. Refer to template for dimensions and depths.

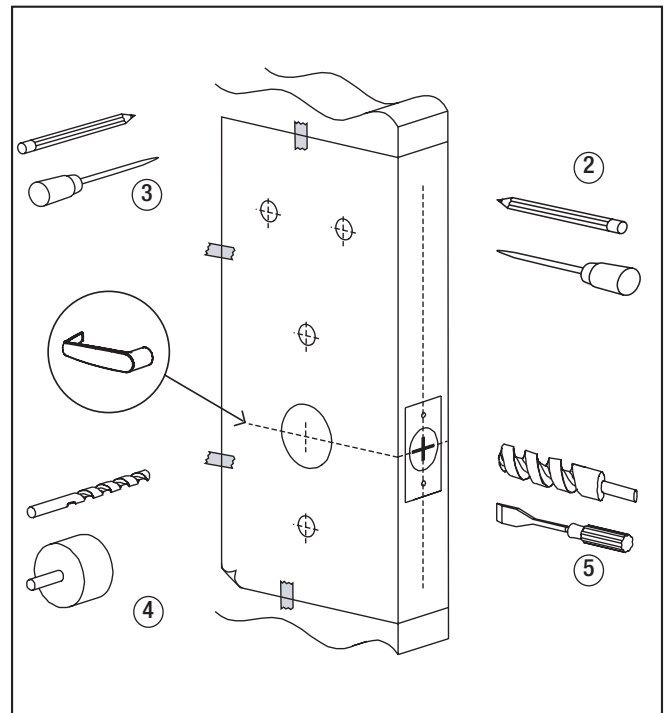

Drill from both sides of the door to prevent unsightly damage.

5. Drill the hole for the latch, and chisel out clearance for the latch plate.

6. Install the latch using 1" Phillips mounting screws. Position the deadlocking pin (D) opposite to the closing direction as shown.

7. Install Strike and strike box.



Use only the strike and strike box supplied. The use of non-approved parts will result in a functionality problem and may void the warranty.

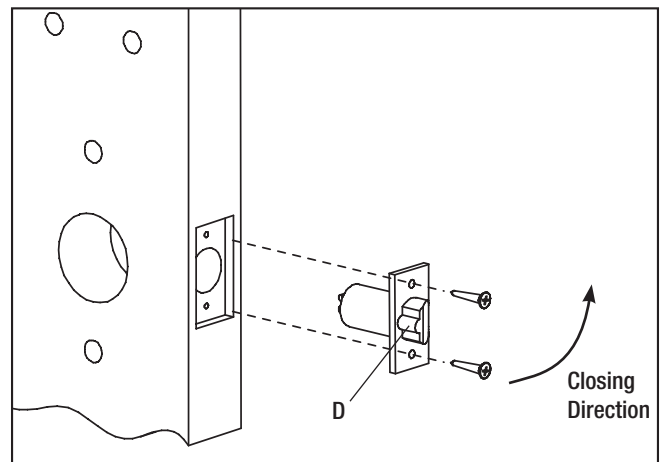

B.3 Install the Cylindrical Unit

Depending on the kind of Spacers shipped with the lock assembled in the factory for 1 3/4" door thickness, choose door thickness Table 1 or door thickness Table 2 to prepare the attachment plate and cylindrical drive unit for the door thickness other than 1 3/4"



It is very important to assemble the spacers in position shown.

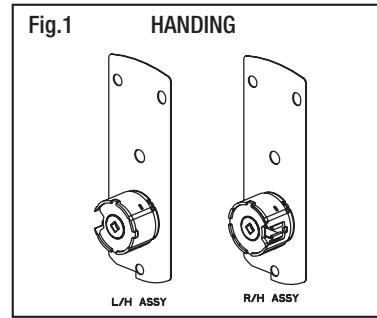

1. Lock with 3 DIFFERENT SPACERS (see fig.2)

The cylindrical Unit and Attachement Plate assembly is shipped assembled in the factory for 1 3/4" door thickness (44mm) with 2 spacers "04", 1 spacer "02" and 2 flat head screws "06" 5/8" LG (see fig.2).

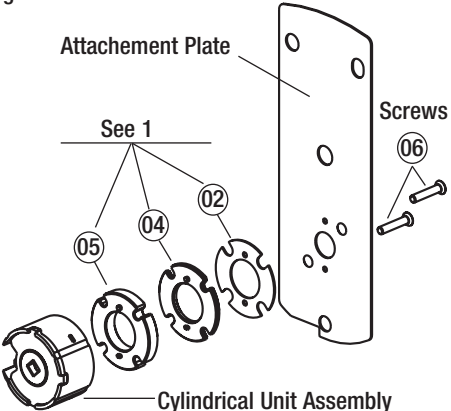
Door Thickness Table 1					Fig.2 
Door Thickness	Spacer 02	Spacer 04	Spacer 05	Screw 06	
1-3/8" (35mm) up to 1-9/16" (40mm)	-	1	-	3/8 (10mm)	
Over 1-9/16" (40mm) to less than 1-11/16" (43mm)	-	2	-	1/2 (13mm)	
1-3/4" (44mm)					
1-11/16" (43mm) to less than 1-7/8" (48mm)	1	2	-	5/8 (16mm)	
1-7/8" (48mm) to 1-15/16" (49mm)	1	-	1	5/8 (16mm)	
Over 1-15/16" (49mm) to less than 2-1/8" (54mm)	2	-	1	3/4 (19mm)	
2-1/8" (54mm) to 2-3/16" (56mm)	-	1	1	3/4 (19mm)	
Over 2-3/16" (56mm) to 2-3/8" (60mm)	2	1	1	7/8 (22mm)	
Over 2-3/8" (60mm) to 2-1/2" (64mm)	-	-	2	7/8 (22mm)	

2. Lock with 2 DIFFERENT SPACERS (see fig.3)

The cylindrical Unit and Attachement Plate assembly is shipped assembled in the factory for 1 3/4" door thickness (44mm) with 2 spacers "07", 1 spacer "08" and 2 flat head screws "06" 5/8" LG (see fig.3).



Door Thickness Table 2				Fig.3 
Door Thickness	Spacer 07	Spacer 08	Screw 06	
1-3/8" (35mm) to 1-9/16" (40mm)	2	-	3/8 (10mm)	
1-5/8" (41mm) to 1-11/16" (43mm)	1	1	1/2 (13mm)	
1-3/4" (44mm) to 1-13/16" (46mm)	2	1	5/8 (16mm)	
1-7/8" (48mm) to 1-15/16" (49mm)	-	2	5/8 (16mm)	
2" (51mm) to 2-1/16" (52.5mm)	1	2	3/4 (19mm)	
2-1/8" (54mm) to 2-3/16" (56mm)	2	2	3/4 (19mm)	
2-1/4" (57mm) to 2-5/16" (59mm)	-	3	7/8 (22mm)	
2-3/8" (60mm) to 2-1/2" (64mm)	1	3	7/8 (22mm)	

Fig. 4
Screw Length (Full Scale)

Length 3/8" Length 1/2" Length 5/8" Length 3/4" Length 7/8"

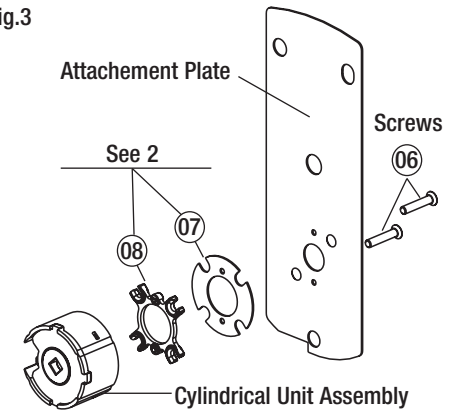

B.3 Install the Cylindrical Unit (con't)

2. Insert the cylindrical unit from the outside of the door toward the inside, so that it engages the latch as shown. This operation is to be done at B.5 step 3.

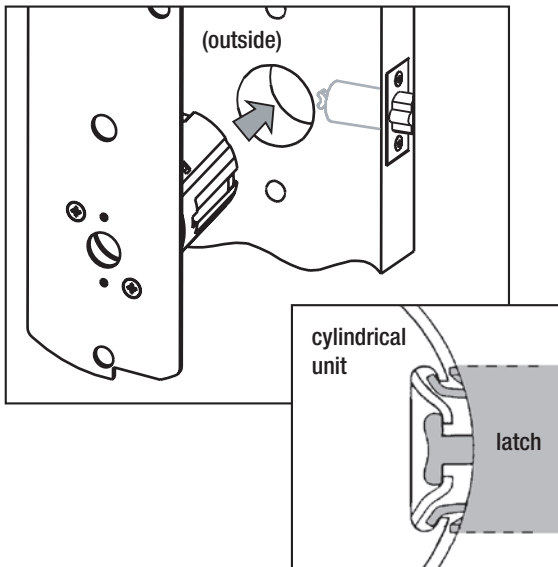

Put the thumbturn in the vertical position as shown on page 34 so that the arrow (A) on the disc points UP.

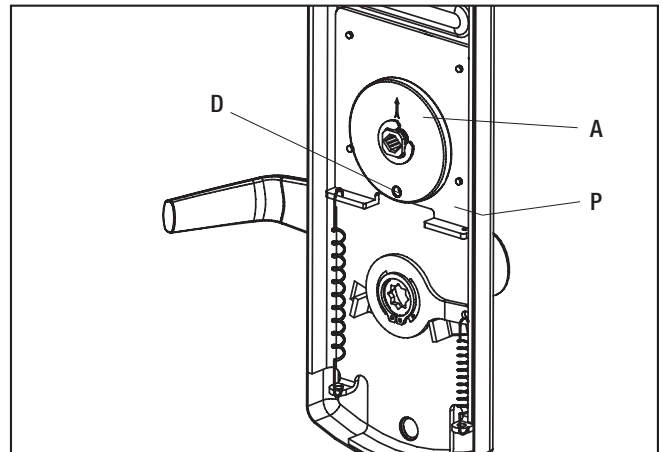

For Inside Trim assembly for cylindrical 79T Toggle mode use the inside trim assembly shown on page 6.

B.4 Inside Trim Assembly for Cylindrical 79M Standard Series

The inside trim assembly for cylindrical includes parts assembled at the factory to control the motion of the thumbturn, and an additional spring.

Do the following **BEFORE** placing the inside trim assembly on the door (page 34, step6):

Install the additional tension spring (N) between the plate (P) and the post (Q), on the side opposite the lever handle spring installed in the last step.

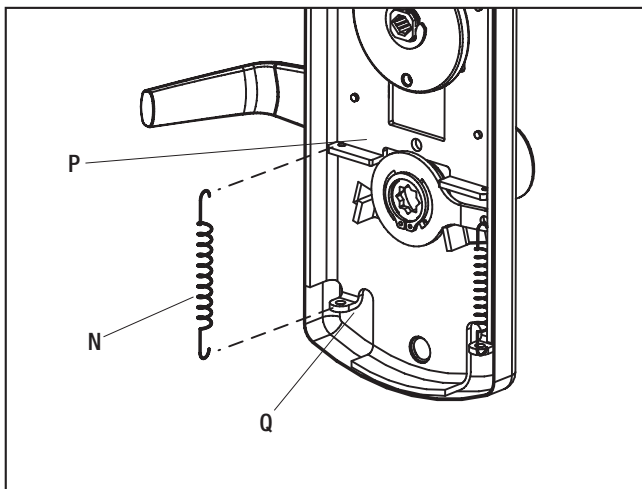

B.5 Install Outside Housing and Trim Assembly for Cylindrical

1. Insert the slotted end of the square spindle (G) into the outside lever hub until it locks, at an angle of 45°. (The spindle can be removed by pulling on it, if oriented incorrectly.)

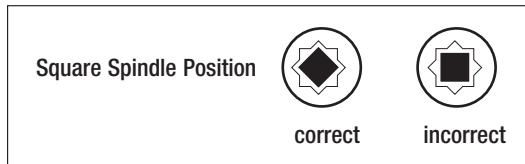

2. Insert the thumbturn spindle (F) in the upper hub of the outside housing. (It will clip in place.)

3. Assemble gasket onto the outside housing. Assemble cylindrical plate assembly onto the outside housing.

4. For 79T Toggle mode, pass cable (W1) through hole (H1) on the door.

5. Place the outside housing on the door so that spindle (F) engages thumbturn hole and spindle (G) engage hub of cylindrical unit. The cylindrical unit will engage the latch as shown in step 2 of B.3 (page 32).

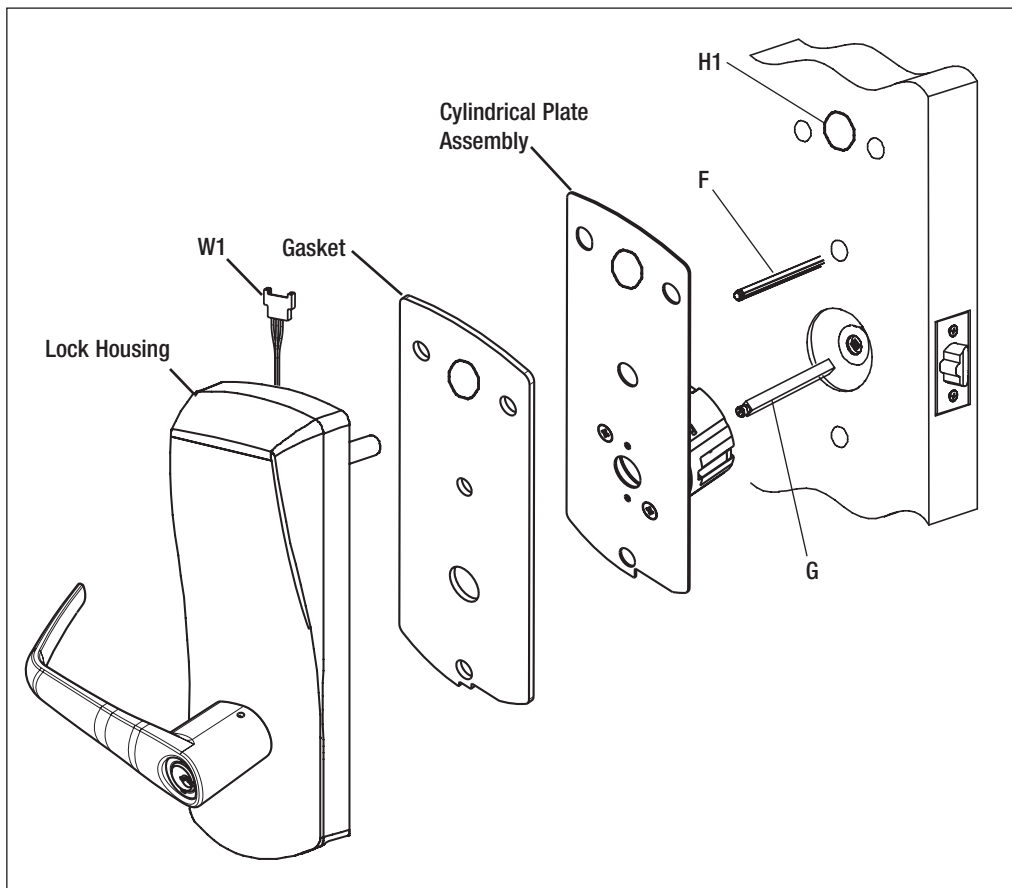

6. Put the thumbturn (T) in a vertical position as shown below. Assemble 3 spacers (S) on the door (for recent models only). For 79T Toggle mode connect (W2) to (W1) and **push both connectors and all excess of wire in hole (H1)**. Place the inside trim assembly on the door so that the upper and lower spindles (F) and (G) engage the thumbturn and the inside lever. Fasten to the outside housing using the three 1/8" hex drive mounting screws (I). Install the screws without tightening. Verify the inside lever and thumbturn operates smoothly. If not move the inside and outside housings slightly. Then tighten the screws.

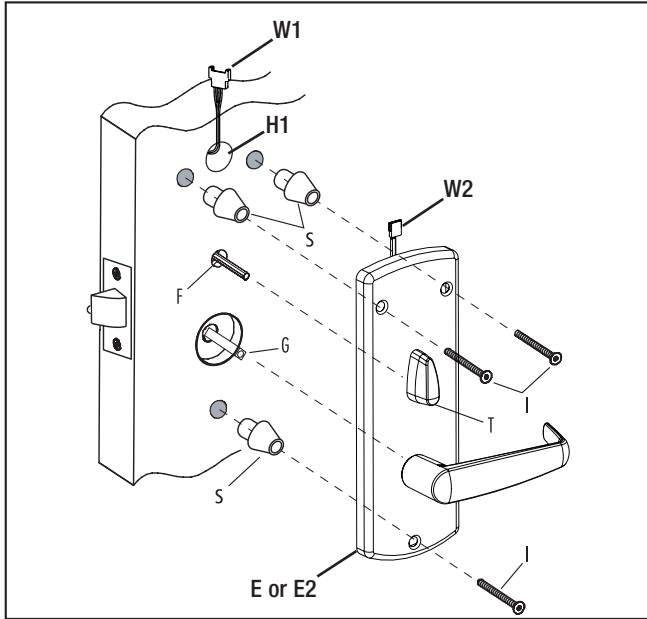

7. Three AA batteries should already be installed in the battery holder (C). Insert the battery holder into the outside housing and secure it using the 6-32 x 5/16" (7.9mm) Torx drive screw (H).

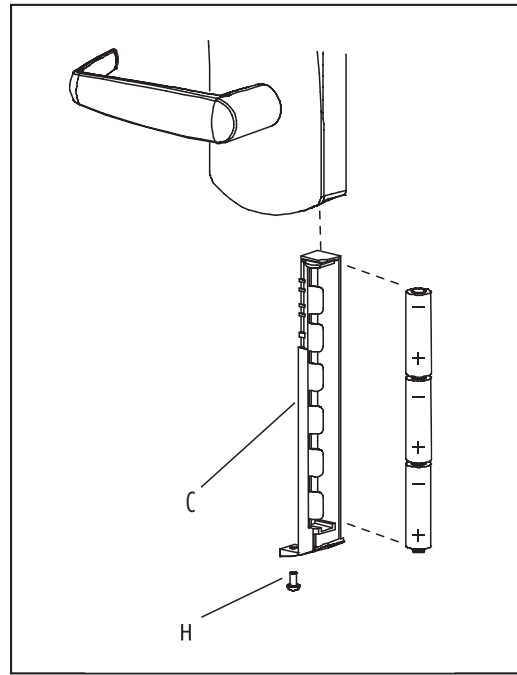

8. Testing the cylindrical lock: Follow all steps of page 12 or 13 but extension and retraction will be for latch only.



If the lock makes a continuous buzzing noise or the red LED lights continuously, reset the electronics by removing the battery holder for ten seconds, then reinsert it.

Note for customers:

Statement according to FCC part 15.105

This equipment has been tested and found to comply with the limits for a Class B digital device, pursuant to Part 15 of the FCC Rules. These limits are designed to provide reasonable protection against harmful interference in a residential installation. This equipment generates, uses, and can radiate radio frequency energy and, if not installed and used in accordance with the instructions, may cause harmful interference to radio communications. However, there is no guarantee that interference will not occur in a particular installation. If this equipment does cause harmful interference to radio or television reception, which can be determined by turning the equipment off and on, the user is encouraged to try to correct the interference by one or more of the following measures:

- Reorient or relocate the receiving antenna.
- Increase the separation between the equipment and receiver.
- Consult the dealer or an experienced radio/TV technician for help.

Statement according to FCC part 15.21

Modifications not expressly approved by Kaba Ilco could void the user's authority to operate the equipment.

Statement according to FCC part 15.19

This device complies with Part 15 of the FCC Rules. Operation is subject to the following two conditions:

- (1) this device may not cause harmful interference, and
- (2) this device must accept any interference received, including interference that may cause undesired operation.



Kaba Ilco Inc.

7301 Boul. Décarie Montréal (QC) H4P 2G7

Technical Support:

1.800.906.4526

Customer Service:

T: 1.877.468.3555

F: 514.735.6589

General Information:

www.ilcolodging.com

Online Consumable Orders:

www.keycard.com

To access all of our easy steps, please visit our Support Website:

<http://connect.kabalodging.com>