



## Test Report

Prepared for: G-Way Incorporated

Model: BDA-PS9-37/37-90-N

Description: DL/896-901 MHz UL/935-940 MHz

Serial Number: 16051002

FCC ID: Q8KPS93790N

To

FCC Part 90

Date of Issue: August 8, 2016

On the behalf of the applicant:

G-Way Incorporated  
38 Leuning St.  
South Hackensack, NJ 07606

Attention of:

Gregory Tsvika Blekher, Project Engineer  
Ph: (201)343-6388  
E-Mail: [tech-support@gwaverf.com](mailto:tech-support@gwaverf.com)

Prepared By  
Compliance Testing, LLC  
1724 S. Nevada Way  
Mesa, AZ 85204  
(480) 926-3100 phone / (480) 926-3598 fax  
[www.compliancetesting.com](http://www.compliancetesting.com)  
Project No: p1660020

**Greg Corbin**  
**Project Test Engineer**

This report may not be reproduced, except in full, without written permission from Compliance Testing  
All results contained herein relate only to the sample tested



### Test Report Revision History

Revision	Date	Revised By	Reason for Revision
1.0	July 22, 2016	Greg Corbin	Original Document
2.0	Nov 1, 2016	Greg Corbin	Clarified statement on page 14 to read "below the -13 dBm limit"



## Table of Contents

<u>Description</u>	<u>Page</u>
Standard Test Conditions and Engineering Practices	6
Test Result Summary	8
AGC Threshold	9
Out of Band Rejection	10
Conducted Output Power and Amplifier Gain	12
Conducted Spurious Emissions	13
Radiated Spurious Emissions	14
Emission Masks (Occupied Bandwidth)	15
Intermodulation	16
Noise Figure Test	17
Test Equipment Utilized	18

**ILAC / A2LA**

Compliance Testing, LLC, has been accredited in accordance with the recognized International Standard ISO/IEC 17025:2005. This accreditation demonstrates technical competence for a defined scope and the operation of a laboratory quality management system (refer joint ISO-ILAC-IAF Communiqué dated January 2009)

The tests results contained within this test report all fall within our scope of accreditation, unless noted below.

Please refer to <http://www.compliancetesting.com/labscope.html> for current scope of accreditation.

Testing Certificate Number: **2152.01**



**FCC Site Reg. #349717**

**IC Site Reg. #2044A-2**

**Non-accredited tests contained in this report:**

**N/A**

**The Applicant has been cautioned as to the following:**

**15.21: Information to the User**

The user's manual or instruction manual for an intentional radiator shall caution the user that changes or modifications not expressly approved by the party responsible for compliance could void the user's authority to operate the equipment.

**15.27(a): Special Accessories**

Equipment marketed to a consumer must be capable of complying with the necessary regulations in the configuration in which the equipment is marketed. Where special accessories, such as shielded cables and/or special connectors are required to enable an unintentional or intentional radiator to comply with the emission limits in this part, the equipment must be marketed with, i.e. shipped and sold with, those special accessories. However, in lieu of shipping or packaging the special accessories with the unintentional or intentional radiator, the responsible party may employ other methods of ensuring that the special accessories are provided to the consumer, without an additional charge.

Information detailing any alternative method used to supply the special accessories for a grant of equipment authorization or retained in the verification records, as appropriate. The party responsible for the equipment, as detailed in § 2.909 of this chapter, shall ensure that these special accessories are provided with the equipment. The instruction manual for such devices shall include appropriate instructions on the first page of text concerned with the installation of the device that these special accessories must be used with the device. It is the responsibility of the user to use the needed special accessories supplied with the equipment.

## Test and Measurement Data

All tests and measurement data shown were performed in accordance with FCC Rules and Regulations Part 90.219, KDB 935210 D05 Booster, and FCC Part 2, where appropriate.

## Standard Test Conditions and Engineering Practices

Except as noted herein, the following conditions and procedures were observed during the testing.

In accordance with ANSI/TIA 603C, and unless otherwise indicated in the specific measurement results, the ambient temperature of the actual EUT was maintained within the range of 10° to 40°C (50° to 104°F) unless the particular equipment requirements specify testing over a different temperature range. Also, unless otherwise indicated, the humidity levels were in the range of 10% to 90% relative humidity.

Environmental Conditions		
Temp (°C)	Humidity (%)	Pressure (mbar)
26.1 – 30.8	28.1 – 41.5	962.5 – 972.0

Measurement results, unless otherwise noted, are worst-case measurements.

### EUT Description

**Model:** BDA-PS9-37/37-90-N

**Description:** DL/896-901 MHz UL/935-940 MHz

**Serial Number:** 16051002

#### Additional Information:

The EUT is classified as a Part 90 PS **Class B** industrial signal booster.

The EUT is a Bi-directional Amplifier that operates in the Frequency ranges listed in Table 1.

System Power is 120 VAC @ 60 Hz.

The emission designators listed in Table 1 are representative emission designators used by transmitters whose signal is amplified by this booster.

**Table 1**

Frequency		Emission Designators
Base to Mobile	Mobile to Base	
935 - 940	896 - 901	F3E, G1D, G1E, W7W, F2D

### EUT Operation during Tests

The EUT was tested under normal operating conditions with the front panel attenuators set to 0 dB for all measurements.

30 dB, 50 watt attenuators were installed on both RF ports for all tests.



**Accessories:** None

**Cables:**

<b>Qty</b>	<b>Description</b>	<b>Length (M)</b>	<b>Shielding Y/N</b>	<b>Shielded Hood Y/N</b>	<b>Termination</b>
1	AC Power Cable	2	N	N	N/A

**Modifications:** None



## Test Result Summary

Specification	Test Name	Pass, Fail, N/A	Comments
KDB 935210-D03	Out of Band Rejection	Pass	
2.1046	Output Power (Conducted)	Pass	
90.210 2.1049	Occupied Bandwidth (Emission Masks)	Pass	
2.1051	Spurious Emissions (Transmitter Conducted)	Pass	
2.1053	Radiated Spurious Emissions	Pass	
KDB 935210-D03	Intermodulation	Pass	
90.219(e)(2)	Noise Figure	Pass	
90.213	Frequency Stability (Temperature Variation)	N/A	
90.213	Frequency Stability (Voltage Variation)	N/A	

**AGC Threshold**
**Engineer:** Greg Corbin

**Test Date:** 7/8/2016

**Test Procedure**

A signal generator producing a CW signal was connected to the input of the EUT. A spectrum analyzer was connected to the EUT in order to monitor the output power levels. The input power level was increase in 1 dB increments until the power no longer increased. The input levels were recorded in the table below.

Spectrum Analyzer settings  
 Power Channel integration  
 RBW = 1-5% of EBW  
 Video BW = 3x RBW

**Test Setup**

**Mobile to Base**

Tuned Frequency (MHz)	AGC Threshold (dBm)
898.5	-49

**Base to Mobile**

Tuned Frequency (MHz)	AGC Threshold (dBm)
937.5	-49.5

## Out of Band Rejection

Engineer: Greg Corbin

Test Date: 7/8/2016

### Test Procedure

The EUT was connected to a spectrum analyzer through a 30 dB power attenuator. A signal generator was utilized to produce a swept CW signal with the RF input level set to 3 dB below the AGC Threshold level. The Uplink and Downlink filter response and the -20 dB bandwidth were measured. The marker table function of the spectrum analyzer was used to show the peak amplitude in the passband and the -20 dB bandwidth of the pass band filter.

RBW = 100 KHz

Video BW = 3x RBW

### Test Setup

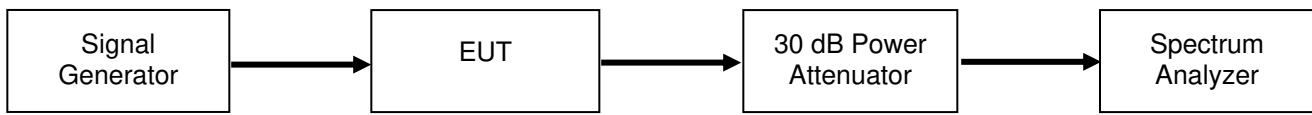

### Out of Band Rejection Test Results

#### Base to Mobile 935 – 940 MHz

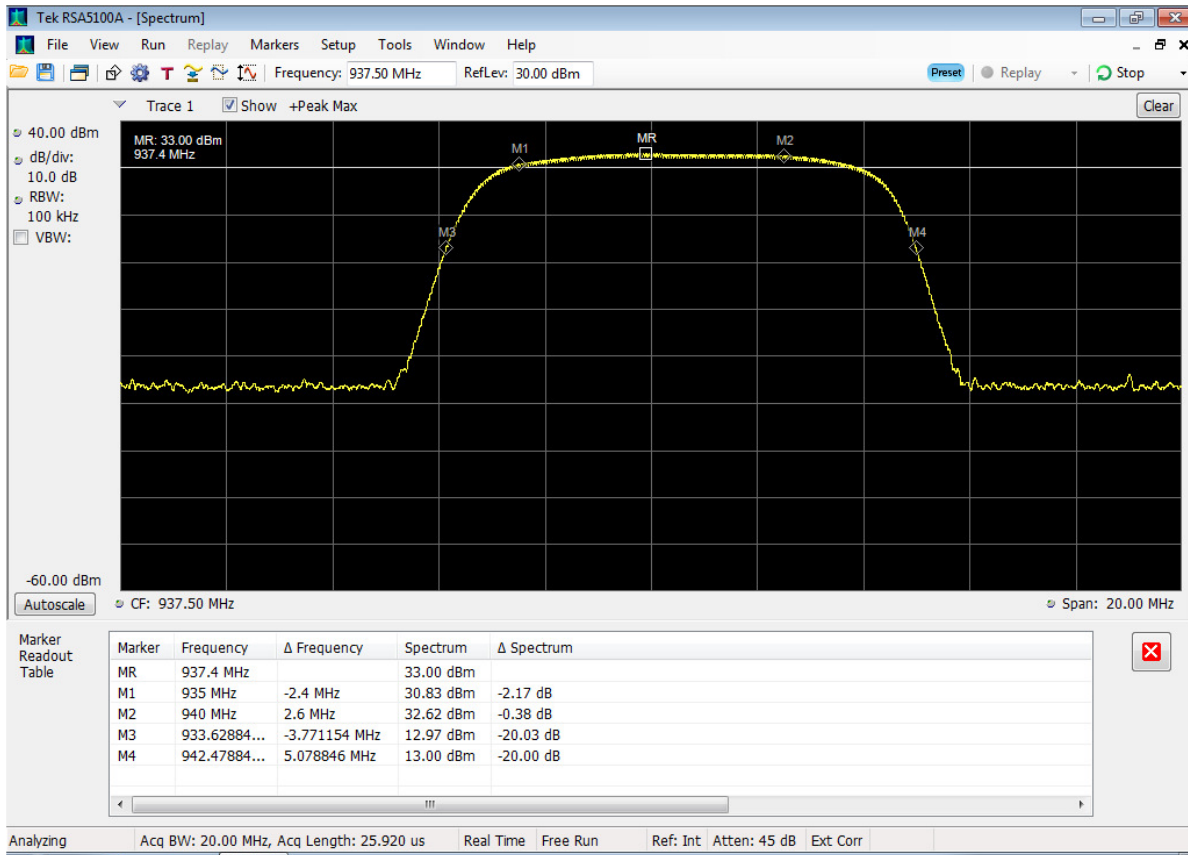



### Mobile to Base 896 – 901 MHz

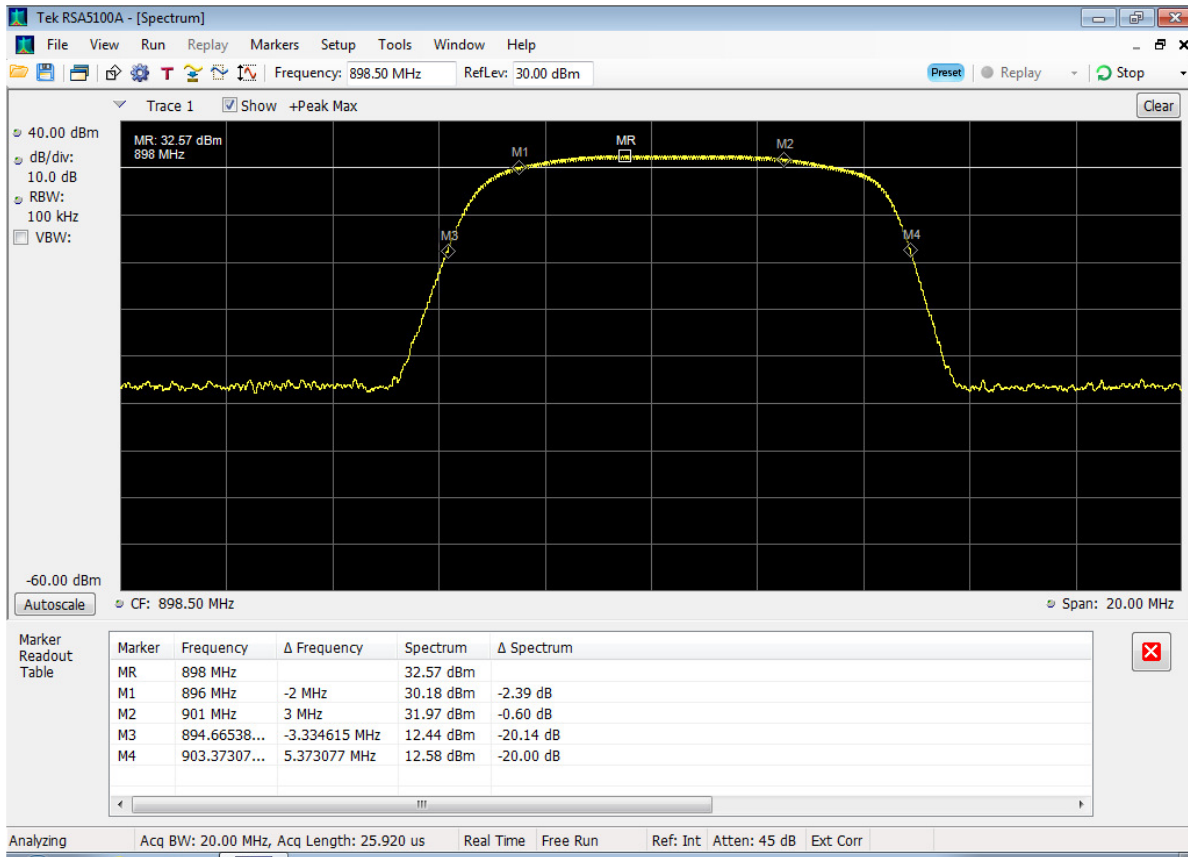

## Conducted Output Power and Amplifier Gain

**Engineer:** Greg Corbin

**Test Date:** 7/8/16

### Test Procedure

The Equipment Under Test (EUT) was connected to a spectrum analyzer through a 30 dB Power attenuator. All cable and attenuator losses were input into the spectrum analyzer as a reference level offset to ensure accurate readings were obtained.

A CW signal was utilized, set to the frequency of the peak amplitude measured in the Out of Band Rejection test.

The RF input signal level was set to 0.2 dB below the AGC Threshold.

RBW = 100 kHz

Video BW = 3x RBW

The Input and Output power levels were recorded and the gain was calculated using the following formula:

$$\text{Gain (dB)} = \text{Output Power (dBm)} - \text{Input Power (dBm)}$$

### Test Setup

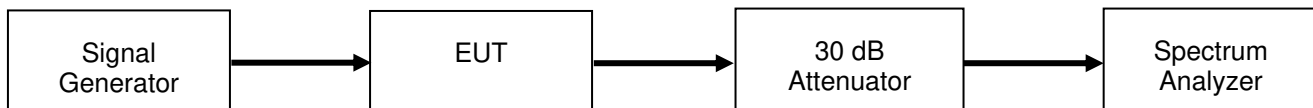

### Output Power and Gain Test Results

Tuned Frequency (MHz)	Input Power (dBm)	Output Power (dBm)	Gain (dB)
898.5	-49.1	35.3	84.4
937.5	-49.3	36.3	85.6

### Radiated Output Power

Radiated Power (ERP) is dependent on the cable loss and antennas used when installed.

The user manual specification for Composite Output Power is 37dBm ± 1dB.

### ALC (Automatic Level Control)

The user manual contains the following statement:

“Each amplifier in the BDA contains an ALC feedback loop. The ALC circuit senses the output power and limits it to the factory preset level, as indicated in the specification.”

## Conducted Spurious Emissions

**Engineer:** Greg Corbin

**Test Date:** 7/11/2016

### Test Procedure

The Equipment Under Test (EUT) was connected to a spectrum analyzer through a 30 dB Power attenuator. All cable and attenuator losses were input into the spectrum analyzer as a combination of reference level offset and correction factor as needed to ensure accurate readings were obtained.

A CW signal was utilized, set to the center frequency of the passband.

The RF input signal level was set to 0.2 dB below the AGC Threshold.

The RBW was set to 100 kHz for measurements below 1 GHz and 1 MHz for measurements above 1 GHz.

The VBW was set to 3 times the RBW.

The frequency range from 30 MHz to the 10<sup>th</sup> harmonic of the passband frequency was observed and plotted.

The following formula was used for calculating the limits.

Conducted Spurious Emissions Limit =  $P1 - (43 + 10\text{Log}(P2)) = -13 \text{ dBm}$

P1 = power in dBm

P2 = power in Watts

### Test Setup

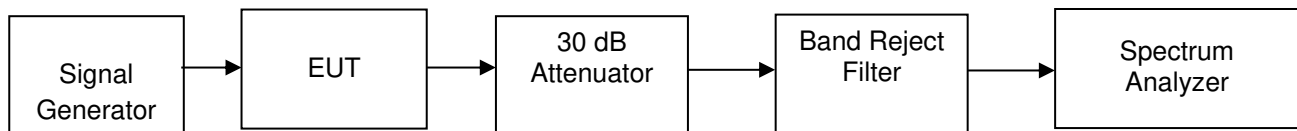

**Refer to Annex A for Conducted Spurious Emissions Plots**

## Radiated Spurious Emissions

**Engineer:** Greg Corbin

**Test Date:** 7/29/2016

### Test Procedure

The EUT was tested in a semi-anechoic chamber with the turntable set 3m from the receiving antenna. A spectrum analyzer was used to verify that the EUT met the requirements for Radiated Emissions. The EUT was tested by rotating it 360 degrees with the antenna in both the vertical and horizontal orientation while raised from 1 to 4 meters to ensure that the signal levels were maximized. All cable and antenna correction factors were input into the spectrum analyzer ensuring an accurate measurement in ERP/EIRP with the resultant power in dBm. A signal generator was used to provide a CW signal. The EUT output was terminated into a 50 Ohm non-radiating load.

The RBW was set to 100 kHz for measurements below 1 GHz and 1 MHz for measurements above 1 GHz. The VBW was set to 3 times the RBW.

The following formula was used for calculating the limits:

Radiated Spurious Emissions Limit =  $P1 - (43 + 10\text{Log}(P2)) = -13\text{dBm}$

P1 = power in dBm

P2 = power in Watts

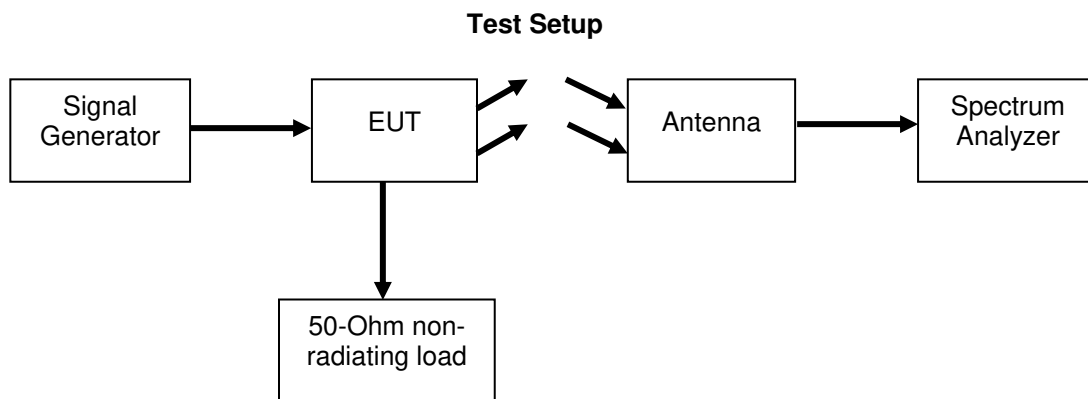

### Test Results

All emissions were below the -13 dBm limit.

**Refer to Annex B for the Radiated Spurious Emissions Plots**

**Emission Masks (Occupied Bandwidth)**

**Engineer:** Greg Corbin

**Test Date:** 7/8/2016

**Test Procedure**

The EUT was connected directly to a spectrum analyzer to verify that the EUT meets the required emissions mask. A reference level plot is provided to verify that the peak power was established prior to testing the mask.

The EUT is a booster amplifier that does not contain a transmitter; representative emission designators used in the industry were used for the emission masks and are listed in Table 1.

The output signal was tested to the required mask.

The input signal was recorded and compared to the output signal.

The input and output was tested at 0.2 dB below the AGC Threshold and +3 dB above the AGC Threshold.

Emission Designator	Emission Mask	Type of Modulation	Occupied Bandwidth (kHz)	Channel Spacing (kHz)	Audio Frequency (kHz)	Deviation (kHz)	RBW (Hz)
11K3F3E	I,J	FM, C4FM	11.3	12.5	1.0	2.5	100

**Test Setup**

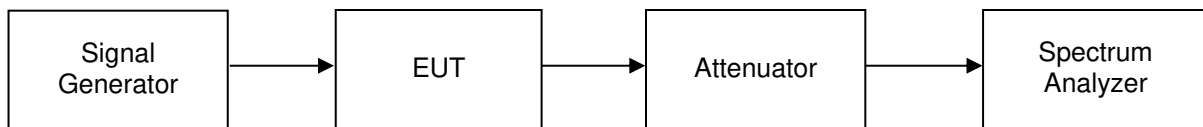

**Refer to Annex C for Emission Mask plots**

**Intermodulation**

**Engineer:** Greg Corbin

**Test Date:** 7/11/2016

**Test Procedure**

The EUT was connected to a spectrum analyzer through a 30 dB power attenuator. Two signal generators were utilized to produce a two tone signal with the 12.5 KHz channel spacing set so the intermodulation products fell within the operational band. Frequency at the maximum power from out of band rejection was utilized.

The Test was performed on both the uplink and downlink .

The RF input signal level was set to 0.2 dB below the AGC Threshold.

RBW = 300 Hz

Video BW = 3x RBW

**Test Setup**

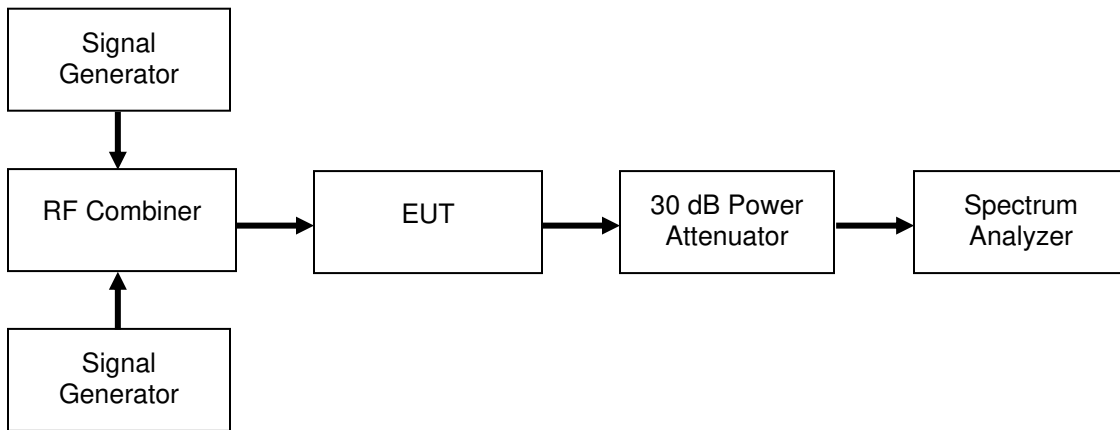

**Refer to Annex D for Intermodulation plots**

**Noise Figure Test**

**Engineer:** Greg Corbin

**Test Date:** 7/11/2016

**Test Procedure**

The test equipment was connected as shown in the test set-up.

The noise figure was measured at the passband center frequency.  
Noise figure was measured using the high power output.



Frequency (MHz)	Noise Figure (dB)	Limit (dB)	Margin (dB)
898.5	3.4	9	5.6
937.5	3.4	9	5.6



### Test Equipment Utilized

Description	Manufacturer	Model #	CT Asset #	Last Cal Date	Cal Due Date
Horn Antenna	ARA	DRG-118/A	i00271	6/16/16	6/16/18
Humidity / Temp Meter	Newport	IBTHX-W-5	i00282	5/26/16	5/26/17
Bi-Log Antenna	Schaffner	CBL 6111D	i00349	10/19/15	10/19/17
EMI Analyzer	Agilent	E7405A	i00379	2/11/16	2/11/17
Signal Generator	Rohde & Schwarz	SMU200A	i00405	1/22/16	1/22/17
Spectrum Analyzer	Textronix	RSA5126A	i00424	3/28/16	3/28/17
3 Meter Semi-Anechoic Chamber	Panashield	3 Meter Semi-Anechoic Chamber	i00428	7/27/14	7/27/17
Noise Figure Meter	Agilent	N8970B	i00444	8/13/15	8/13/16
Noise Source	Agilent	346A	i00445	8/28/15	8/28/16
Preamplifier	Miteq	AFS44 00101 400 23-10P-44	i00509	N/A	N/A

In addition to the above listed equipment standard RF connectors and cables were utilized in the testing of the described equipment. Prior to testing these components were tested to verify proper operation.

END OF TEST REPORT