



Shenzhen Certification Technolgh Service Co., Ltd  
3F, Bldg27,Area A, Tanglang Industrial Zone, Xili Town,  
Nanshan District, ShenZhen, Guang dong, P.R.  
China.

# TEST REPORT

**FCC ID: Q87CTV1RM**

**Applicant** : Cisco Systems, Inc.  
**Address** : 30 Maiden Lane, 6th Floor, San Francisco, CA 94108, USA

**Equipment under Test (EUT):**

**Name** : RF control  
**Model** : CTV1RM  
**Standards** : FCC PART 15, SUBPART C : 2008 (Section 15.231)

**Report No.** : STE090828487  
**Date of Test** : September 1-2, 2009  
**Date of Issue** : September 4, 2009

<b>Test Result :</b>	<b>PASS *</b>
----------------------	---------------

\* In the configuration tested, the EUT complied with the standards specified above

Authorized Signature

(Mark Zhu)  
General Manager

The manufacture should ensure that all the products in series production are in conformity with the product sample detailed in this report.

If the product in this report is used in any configuration other than that detailed in the report, the manufacturer must ensure the new system complies with all relevant standards. Any mention of Shenzhen Certification Technology Service Co., Ltd. Or test done by Shenzhen Certification Technology Service Co., Ltd. Approvals in connection with, distribution or use of the product described in this report must be approved by Shenzhen Certification Technology Service Co., Ltd. Approvals in writing.

## TABLE OF CONTENT

Description	Page
<b>1 General Information</b> -----	<b>3</b>
1.1 Description of Device (EUT)-----	3
1.2 Description of Test Facility-----	4
<b>2 EMC Equipment List</b> -----	<b>4</b>
<b>3 Test Procedure</b> -----	<b>5</b>
<b>4 Summary of Measurement</b> -----	<b>6</b>
<b>Occupied bandwidth</b> -----	<b>6</b>
<b>5 Radiation Emission</b> -----	<b>7</b>
5.1 Radiation Emission Limits(15.209&231)-----	7
5.2 Test Setup-----	7
5.3 Test Procedure-----	9
5.4 Test Equipment Setting For emission test.est Result-----	10
5.5 Test Condition-----	10
5.6 Test Result-----	10
<b>6 Occupied bandwidth</b> -----	<b>14</b>
6.1 Test limit-----	14
6.2 Method of measurement-----	14
6.3 Test Setup-----	14
6.4 Test Results-----	14
<b>7 Transmission time</b> -----	<b>16</b>
7.1 Test limit-----	16
7.2 Method of measurement-----	16
7.3 Test Setup-----	16
7.4 Test Results-----	16
<b>8 Band Edge Check</b> -----	<b>18</b>
8.1 Test limit-----	18
8.2 Test Procedure-----	18
8.3 Test Setup-----	18
8.4 Test Result-----	18
<b>9 Antenna Requirement</b> -----	<b>19</b>
9.1 Standard Requirement-----	19
9.2 Antenna Connected Construction-----	19
9.3 Result-----	19
<b>10 Photographs of Test Setup</b> -----	<b>20</b>
<b>11 Photographs of EUT</b> -----	<b>21</b>

# 1 General Information

## 1.1 Description of Device (EUT)

Trade Name : Cisco

EUT : RF control

Model No. : CTV1RM

Type of Antenna : Integral Antenna

Operation Frequency : 433.9 MHZ

Channel number : 1

Modulation type : ASK

Power Supply : DC 3V

Rated PF  
output Power : 84.66dBuV(PK detector)

Applicant : Cisco Systems, Inc.

Address : 30 Maiden Lane, 6th Floor, San Francisco, CA 94108,USA

Manufacturer : Xiamen Hello Electronics., Ltd

Address : No.808 Jiahe Road Xiamen, P.R. China

## 1.2 Description of Test Facility

Most Technology Service Co.,Ltd.  
 No.5, 2<sup>nd</sup> Langshan Road, North District Gi-tech  
 Industrial Park,Nanshan, Guangdong, China  
 FCC Registered No.:490827

## 2 EMC Equipment List

Equipment	Manufacture	Model No.	Serial No.	Last cal.	Cal Interval
3m Semi-Anechoic	ETS-LINDGREN	N/A	SEL0017	16/06/2009	1Year
Spectrum analyzer	Agilent	E4443A	MY46185649	06/06/2009	1Year
Receiver	R&S	ESCI	100492	04/06/2009	1Year
Receiver	R&S	ESCI	101202	07/01/2009	1Year
Bilog Antenna	Sunol	JB3	A121206	04/06/2009	1Year
Horn Antenna	EMCO	3115	640201028-06	04/06/2009	1Year
Power Meter	Anritsu	ML2487A	6K00001491	02/23/2009	1Year
ETS Horn Antenna	ETS	3160	SEL0076	12/08/2009	1Year
Active Loop Antenna	Beijing Daze	ZN30900A	SEL0097	15/06/2009	1Year
Cable	Resenberger	N/A	No.1	04/06/2009	1Year
Cable	SCHWARZBECK	N/A	No.2	04/06/2009	1Year
Cable	SCHWARZBECK	N/A	No.3	04/06/2009	1Year
Pre-amplifier	R&S	AFS42-00101 800-25-S-42	SEL0081	18/06/2009	1Year
Pre-amplifier	R&S	AFS33-18002650 -30-8P-44	SEL0080	18/06/2009	1Year

### 3 Test Procedure

**POWER LINE CONDUCTED INTERFERENCE:** The test procedure used was ANSI Standard C63.4-2003 using a 50  $\mu$  H LISN. Both Lines were observed. The bandwidth of the receiver was 10kHz with an appropriate sweep speed. The ambient temperature of the EUT was 25°C with a humidity of 58%.

**RADIATION INTERFERENCE:** The test procedure used was ANSI Standard C63.4-2003 using a ANRITSU spectrum analyzer with a pre-selector. The analyzer was calibrated in dB above a micro volt at the output of the antenna. The resolution bandwidth was 100kHz and the video bandwidth was 300 kHz up to 1 GHz and 1 MHz with a video BW of 3MHz above 1 GHz. The ambient temperature of the EUT was 25°C with a humidity of 58%.

**FORMULA OF CONVERSION FACTORS:** The Field Strength at 3m was established by adding the meter reading of the spectrum analyzer (which is set to read in units of dBuV) to the antenna correction factor supplied by the antenna manufacturer and cable loss. The antenna correction factors and cable loss are stated in terms of dB. The gain of the Pre-selector was accounted for in the Spectrum Analyzer Meter Reading.

Example:

Freq (MHz) METER READING + ACF + CABLE = FS

33.20 dBuV + 10.36 dB + 0.9 dB= 44.46 dBuV/m @ 3m

**ANSI STANDARD C63.4-2003 10.1.7 MEASUREMENT PROCEDURES:** The EUT was placed on a table 80 cm high and with dimensions of 1m by 1.5m. The EUT was placed in the center of the table (1.5m side). The table used for radiated measurements is capable of continuous rotation. When an emission was found, the table was rotated to produce the maximum signal strength. At this point, the antenna was raised and lowered from 1m to 4m. The antenna was placed in both the horizontal and vertical planes. The situation was similar for the conducted measurement except that the table did not rotate. The EUT was setup as described in ANSI Standard C63.4-2003 10.1.7 with the EUT 40 cm from the vertical ground wall.

---

## 4 Summary of Measurement

Test Item	Test Requirement	Standard Paragraph	Result
Spurious Emission	FCC PART 15 : 2008	Section 15.231&15.209	Compliance
Conduction Emission	FCC PART 15: 2008	Section 15.207	Not applicable
Occupied bandwidth	FCC PART 15:2008	Section 15.231	Compliance
Transmission time	FCC PART 15:2008	Section 15.231	Compliance
Band Edge	FCC PART 15:2008	Section 15.231	Not applicable
Antenna Requirement	FCC PART 15 : 2008	Section 15.203	Compliance

Note: The EUT has been tested as an independent unit. And Continual Transmitting in maximum power(The new battery be used during Test)

## 5 Radiation Emission

### 5.1 Radiation Emission Limits(15.209&231)

Frequency (MHZ)	Field Strength Limits at 3 metres (watts,e.i.r.p.)		
	uV/m	dB uV/m	Measurement distance(m)
0.009-0.490	2400/F(kHz)	XX	300
0.490-1.705	24000/F(kHz)	XX	30
1.705-30	30	29.5	30
30~88	100(3nW)	40	3
88~216	150(6.8nW)	43.5	3
216~960	200(12nW)	46	3
Above960	500(75nW)	54	3
Carrier frequency		89.58(AV)	3
Carrier frequency		100.8(PK)	3

**NOTE:**

- a) The tighter limit applies at the band edges.
- b) Emission Level(dB uV/m)=20log Emission Level(Uv/m)
- c) Average should be determined by duty cycle factor.  
 the pulse train is 108ms which is greater than 100ms.  
 So the total on time in 100ms is = 33\* 560usec + 9 ms = 27.48ms, Duty cycle factor = 20 log (24.78/100) = -11.22 dB  
 Average = peak value – 11.22 dB

### 5.2 Test Setup

See the next page

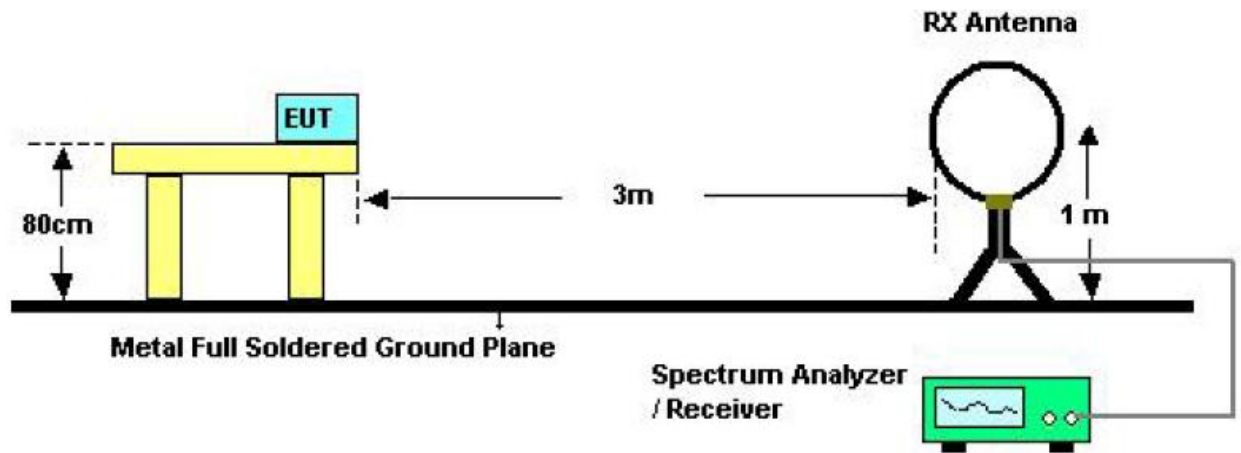

Below 30MHz Test Setup

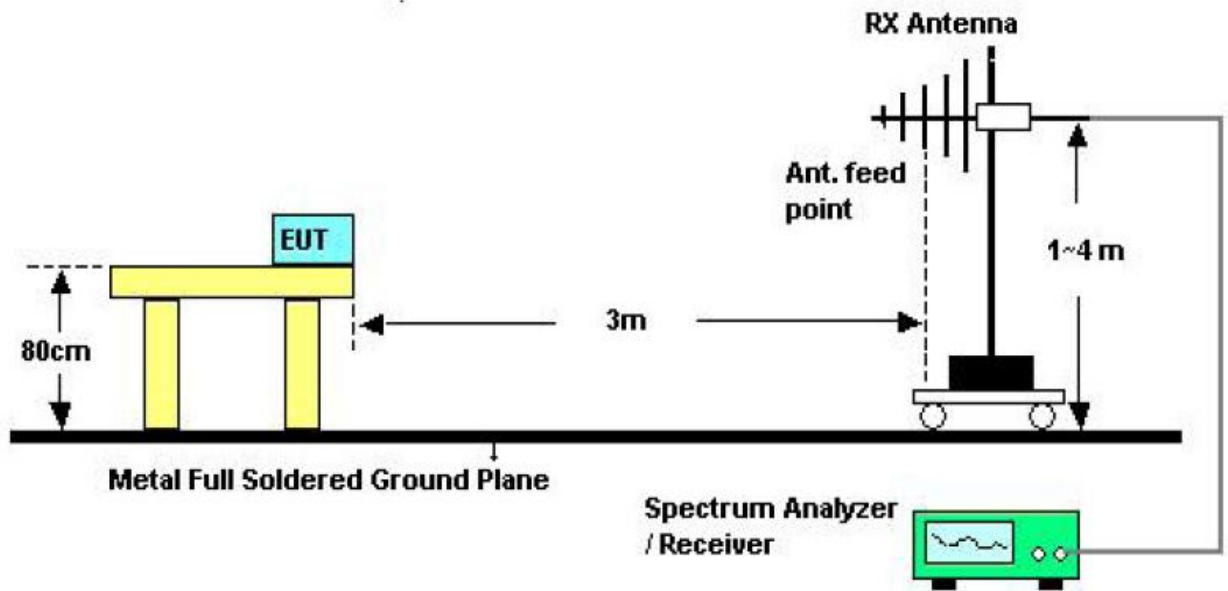

Above 30MHz Test Setup



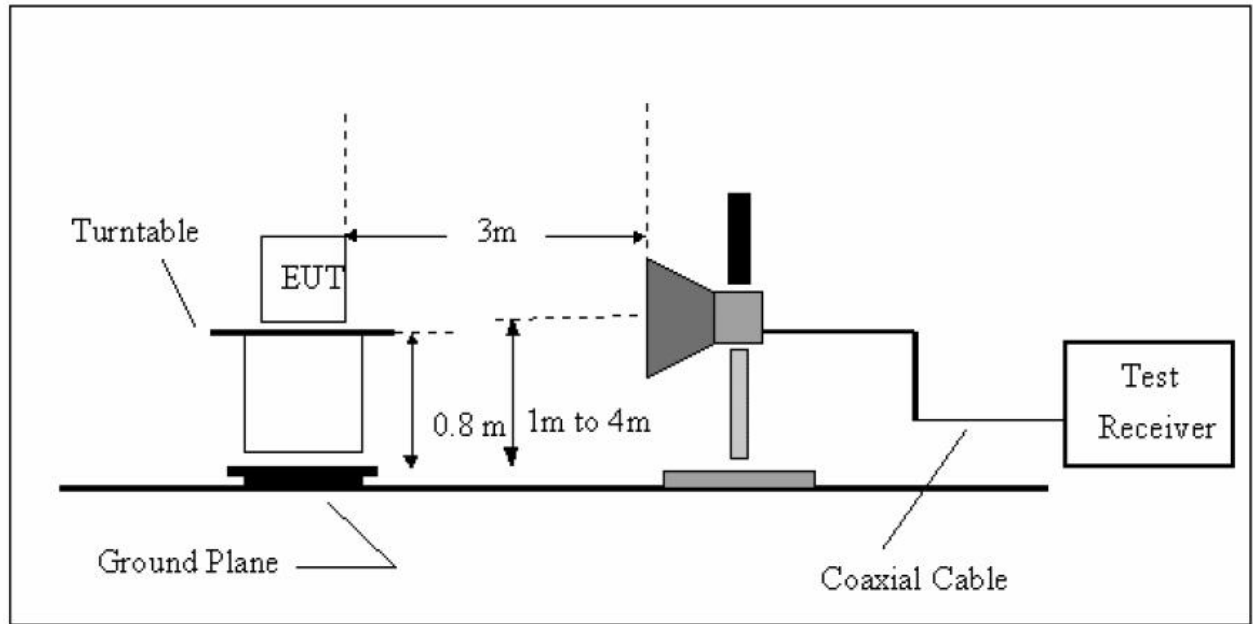

Above 1GHZ Test Setup

### 5.3 Test Procedure

- a) The measuring distance of 3m shall be used for measurements at frequency up to 1GHZ and above 1GHZ, The EUT was placed on a rotating 0.8 m high above ground,The table was rotated 360 degrees to determine the position of the highest radiation
- b) The Test antenna shall vary between 1m and 4m,Both Horizontal and Vertical antenna are set ot make measurement.
- c) The initial step in collecting conducted emission data is a spectrum analyzer Peak detector mode pre-scanning the measurement frequency range.Significant Peaks are then marked.and then Qusia Peak Detector mode remeasured
- d) If Peak value comply with QP limit Below 1GHZ.The EUT deemed to comply with QP limit.But the Peak value and average value both need to comply with applicable limit above 1GHZ.
- e) For the actual test configuration,please see the test setup photo.

#### 5.4 Test Equipment Setting For emission test.est Result

9KHZ~150KHZ	RBW 200HZ	VBW1KHZ
150KHZ~30MHZ	RBW 9KHZ	VBW 30KHZ
30MHZ~1GHZ	RBW 120KHZ	VBW 300KHZ
Above 1GHZ	RBW 1MHZ	VBW 3MHZ

#### 5.5 Test Condition

Continual Transmitting in maximum power(The new battery be used during Test)

#### 5.6 Test Result

Detailed information please see the following page.

<b>EUT</b>	RF control	<b>Model Name</b>	CTV1RM
<b>Temperature</b>	25°C	<b>Relative Humidity</b>	57%
<b>Pressure</b>	960hPa	<b>Test voltage</b>	DC 3V
<b>Test Mode</b>	TX		

Freq. (MHz)	Ant.Pol. H/V	Detector Mode (PK/OP)	Reading (dBuV)	Factor (dB)	Actual FS (dBuV/m)	Limits 3m (dBuV/m)	Margin (dBuV/m)
102.450	V	Peak	46.34	-15.58	30.76	43.50	-12.74
129.450	V	Peak	52.03	-16.62	35.41	43.50	-8.09
276.150	V	Peak	46.82	-11.74	35.08	46.00	-10.92
652.333	V	Peak	42.30	-4.94	37.36	46.00	-8.64
662.833	V	Peak	43.70	-4.76	37.94	46.00	-7.06
798.166	V	Peak	41.59	-3.86	37.73	46.00	-8.27

<b>EUT</b>	RF control	<b>Model Name</b>	CTV1RM
<b>Temperature</b>	26°C	<b>Relative Humidity</b>	56%
<b>Pressure</b>	960hPa	<b>Test voltage</b>	DC 3V
<b>Test Mode</b>	TX		

Freq. (MHz)	Ant.Pol. H/V	Detector Mode (PK/OP)	Reading (dBuV)	Factor (dB)	Actual FS (dBuV/m)	Limits 3m (dBuV/m)	Margin (dBuV/m)
91.200	H	Peak	51.18	-15.90	35.28	43.50	-8.22
160.050	H	Peak	49.78	-15.03	36.75	43.50	-8.75
247.800	H	Peak	49.46	-12.49	36.97	46.00	-9.03
350.166	H	Peak	46.70	-9.34	37.36	46.00	-8.64
715.333	H	Peak	42.63	-4.19	38.44	46.00	-7.56
797.000	H	Peak	40.96	-3.87	37.09	46.00	-8.91

**Notes:** Above is Below 1GHZ test data

<b>EUT</b>	RF control	<b>Model Name</b>	CTV1RM
<b>Temperature</b>	25°C	<b>Relative Humidity</b>	57%
<b>Pressure</b>	960hPa	<b>Test voltage</b>	DC 3V
<b>Test Mode</b>	TX		

Freq. (MHz)	Ant. Pol H/V	Peak Reading (dBuV)	AV Reading (dBuV)	Ant. / CL CF (dB)	Actual Fs		Peak Limit (dBuV/m)	AV Limit (dBuV/m)	Margin (dB)	Remark
					Peak (dBuV/m)	AV (dBuV/m)				
1060.00	V	58.10	---	-11.84	46.26	---	74.00	54.00	-8.89	Peak
1593.00	V	57.88	---	-9.05	48.83	---	74.00	54.00	-5.17	Peak
2766.66	V	51.13	---	-4.74	46.39	---	74.00	54.00	-7.61	Peak
4013.00	V	46.20	---	0.64	46.84	---	74.00	54.00	-8.16	Peak
N/A										

<b>EUT</b>	RF control	<b>Model Name</b>	CTV1RM
<b>Temperature</b>	25°C	<b>Relative Humidity</b>	57%
<b>Pressure</b>	960hPa	<b>Test voltage</b>	DC 3V
<b>Test Mode</b>	TX		

Freq. (MHz)	Ant. Pol H/V	Peak Reading (dBuV)	AV Reading (dBuV)	Ant. / CL CF (dB)	Actual Fs		Peak Limit (dBuV/m)	AV Limit (dBuV/m)	Margin (dB)	Remark
					Peak (dBuV/m)	AV (dBuV/m)				
1060.00	H	57.61	---	-11.84	45.77	---	74.00	54.00	-8.23	Peak
1600.00	H	56.31	---	-9.03	47.28	---	74.00	54.00	-6.72	Peak
2766.67	H	48.58	---	-4.74	43.84	---	74.00	54.00	-10.16	Peak
3972.00	H	43.49	---	0.14	43.63	---	74.00	54.00	-10.37	Peak
N/A										

**Notes:**AV Means AV detector test data,Peak Means Peak detector test data.  
Emissions attenuated more than 20 dB below the permissible value are not reported.

Radiated Emissions Result of Inside band (433.9MHZ)

<b>EUT</b>	RF control	<b>Model Name</b>	CTV1RM
<b>Temperature</b>	25°C	<b>Relative Humidity</b>	57%
<b>Pressure</b>	960hPa	<b>Test voltage</b>	DC 3V
<b>Test Mode</b>	TX	<b>Antenna polarization</b>	Horizontal/Vertical

Channel Low(433.9MHZ)									
Fre. MHz	Plority H/V	Reading dBuV	Antenna Factor dB	Cable Loss dB	Amplifier Gain dB	Correct Factor dB	Measure Result dBuV/m	Limit dBuV/m	Margin dB
433.9	H	105.59 (PK)	7.1	0.84	30.16	-22.22	83.37	108.8	-25.43
433.9	H	94.37 (AV)	7.1	0.84	30.16	-22.22	72.15	89.58	-17.96
--	H	--	--	--	--	--	--	--	--
433.9	V	106.88 (PK)	7.1	0.84	30.16	-22.22	84.66	108.8	-24.14
433.9	V	95.66 (AV)	7.1	0.84	30.16	-22.22	73.44	89.58	-17.65
--	V	--	--	--	--	--	--	--	--

**Notes: 1** --Means other frequency and mode comply with standard requirements and at least have 20dB margin.  
 Correct Factor=Cable Loss+Antenna Factor-Amplifier Gain  
 Measurement Result=Reading + Correct Factor  
 Margin=Measurement Result-Limit

**2** –Spectrum setting:  
 a. Peak setting 30MHz-1GHz,RBW=120KHz,VBW=300KHz.  
 b. AV setting 30MHz-1GHz,RBW=1MHz,VBW=10Hz.

## 6 Occupied bandwidth

### 6.1 Test limit

Please refer section 15.231

According to § 15.231(C), The bandwidth of the emission shall be no wider than 0.25% of the center frequency for devices operating above 70MHz and below 900MHz.

### 6.2 Method of measurement

a) The bandwidth is measured at an amplitude level reduced 20dB from the reference level. The reference level is the level of the highest amplitude signal observed from the transmitter at the fundamental frequency. Once the reference level is established, the equipment is conditioned with typical modulating signal to produce the worst-case (i.e. the widest) bandwidth.

b) The test receiver RBW set 30KHZ, VBW set 30KHZ, Sweep time set auto.

### 6.3 Test Setup

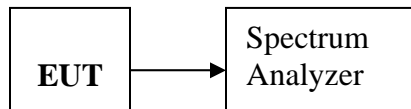

### 6.4 Test Results

**PASS.**

Detailed information please see the following page.

Frequency	Test Result	Limit	Result
433.9Mhz	120KHz	<1.08MHz	Pass

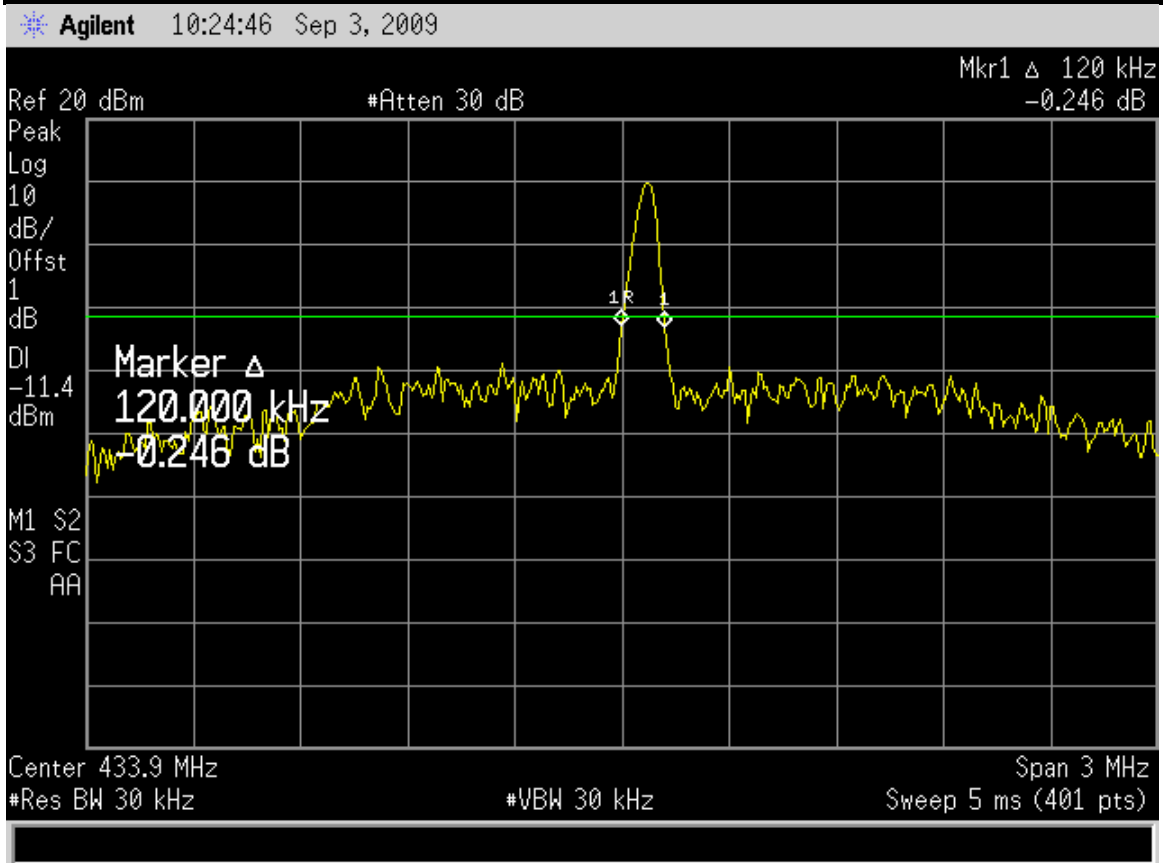

## 7 Transmission time

### 7.1 Test limit

Please refer section 15.231

According to § 15.231(a)(1), A manually operated transmitter shall employ a switch that will automatically deactivate the transmitter within not more than 5 seconds of being released.

According to § 15.231(a)(2), A transmitter activated automatically shall cease transmission within 5 seconds after activation.

### 7.2 Method of measurement

9.2.1. Place the EUT on the table and set it in transmitting mode.

9.2.2. Remove the antenna from the EUT and then connect a low loss RF cable from the antenna port to the spectrum analyzer.

9.2.3. Set spectrum analyzer Center=433.9MHz, Span = 0MHz, Sweep = 200ms.

9.2.4. Set the spectrum analyzer as RBW, VBW=1MHz,

9.2.5. Max hold, view and count how many channel in the band.

### 7.3 Test Setup

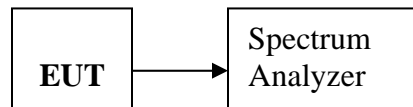

### 7.4 Test Results

**PASS.**

Detailed information please see the following page.



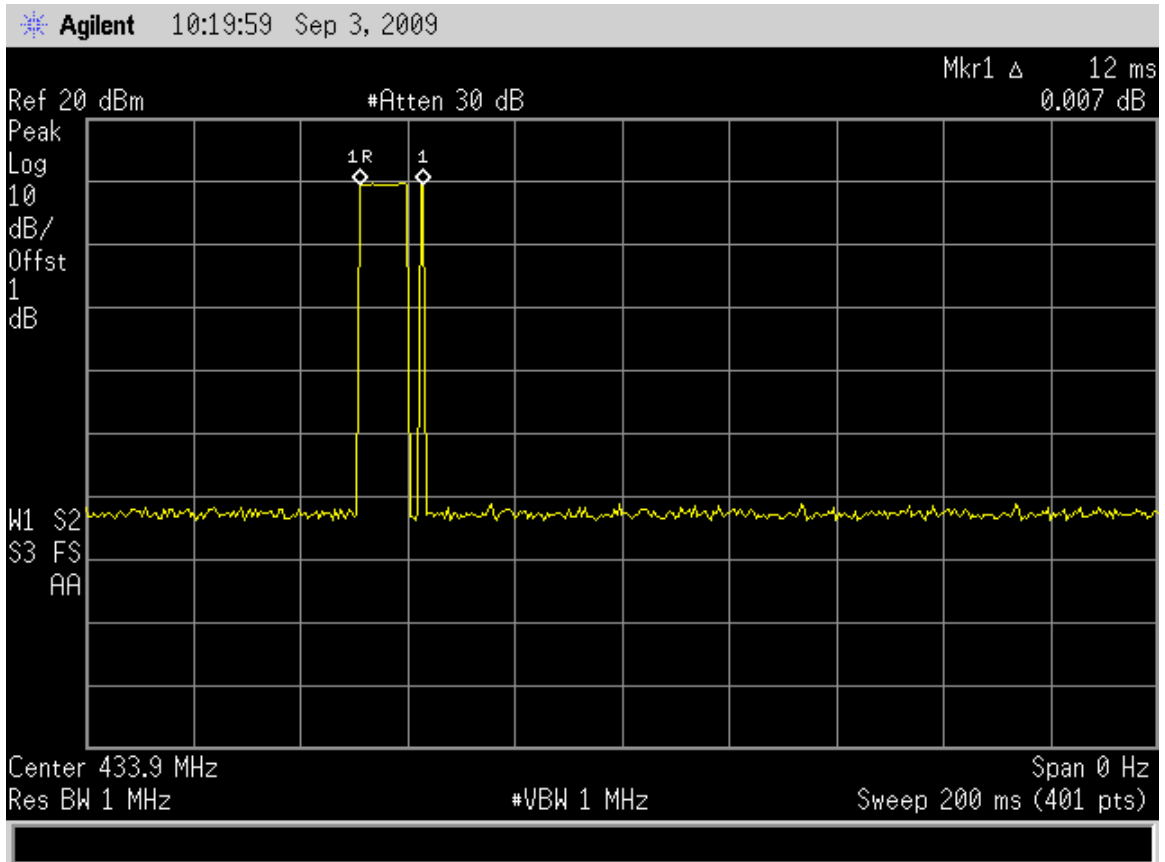

## 8 Band Edge Check

### 8.1 Test limit

Please refer section 15.231 and section 15.205.

Emissions radiated outside of the specified frequency bands, except for harmonics, shall be attenuated by at least 50 dB below the level of the fundamental or to the general radiated emission limits in Section 15.209, whichever is the lesser attenuation.

### 8.2 Test Procedure

11.2.1 Put the EUT on a 0.8m high table, power on the EUT. Emissions were scanned and measured rotating the EUT to 360 degrees, Find the maximum Emission

11.2.2 Turning to Low and High frequency, then reduced 50dB from the reference level. The reference level is the level of the highest amplitude signal observed from the transmitter at the fundamental frequency.

11.2.3 Check the spurious emissions out of band.

11.2.4 RBW, VBW Setting, please see the following test plot.

### 8.3 Test Setup

Same to 5.2.

### 8.4 Test Result

The Restricted bands is 399.9-410MHz and 608-614MHz, The eut operation frequency is 433.9MHz, The test is not applicable.

## 9 Antenna Requirement

### 9.1 Standard Requirement

An intentional radiator shall be designed to ensure that no antenna other than that furnished by the responsible party shall be used with the device. The use of a permanently attached antenna or of an antenna that uses a unique coupling to the intentional radiator shall be considered sufficient to comply with the provisions of this Section. The manufacturer may design the unit so that a broken antenna can be replaced by the user, but the use of a standard antenna jack or electrical connector is prohibited.

### 9.2 Antenna Connected Construction

The directional gains of antenna used for transmitting is 0 dBi, and the antenna connector is designed with permanent attachment and no consideration of replacement. Please see EUT photo for details.

### 9.3 Result

The EUT antenna is integral Antenna. It comply with the standard requirement.

## 10 Photographs of Test Setup

### Photographs-Radiated Emission Test Setup in Chamber



## 11 Photographs of EUT

**Figure 1**

Photo of EUT

Front View [ ]

Rear View [ ]

Top View [  ]

Bottom View [ ]

Left View [ ]

Right View [ ]

Full View [ ]



**Figure 2**

Photo of EUT

Front View [ ]

Rear View [ ]

Top View [ ]

Bottom View [  ]

Left View [ ]

Right View [ ]

Full View [ ]



**Figure 3**

Photo of EUT

Front View

Rear View

Top View

Bottom View

Left View

Right View

Internal View

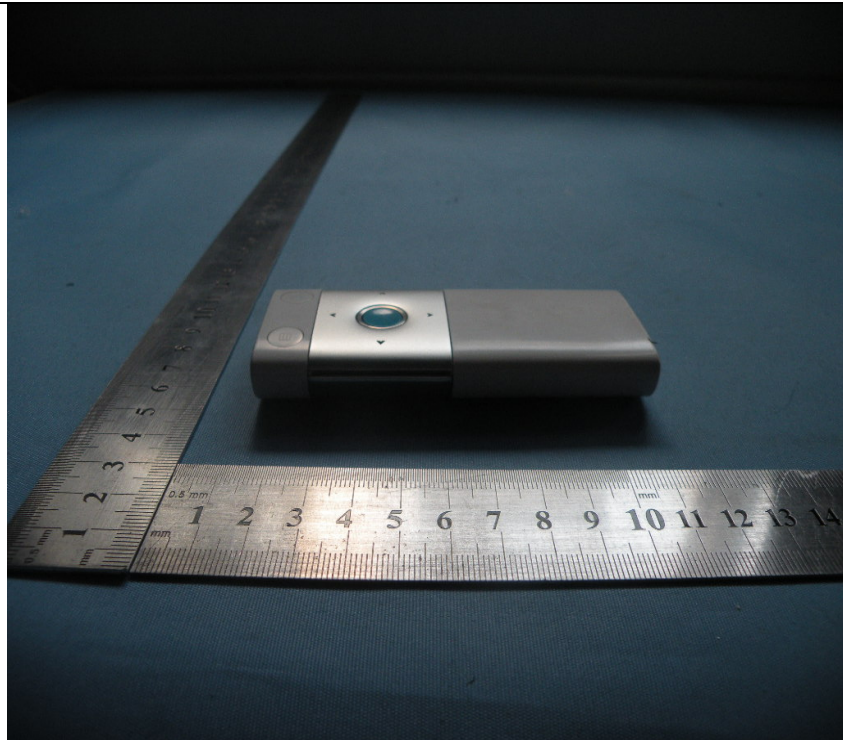

**Figure 4**

Photo of EUT

Front View

Rear View

Top View

Bottom View

Left View

Right View

Internal View

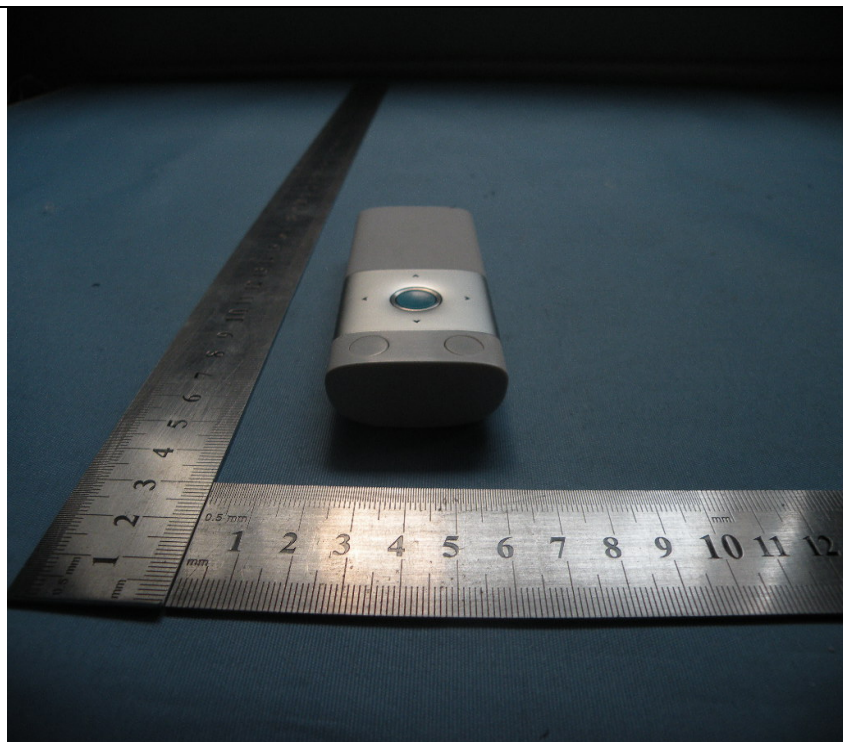

**Figure 5**

Photo of EUT

Front View [ ]

Rear View [  ]

Top View [ ]

Bottom View [ ]

Left View [ ]

Right View [ ]

Internal View [ ]

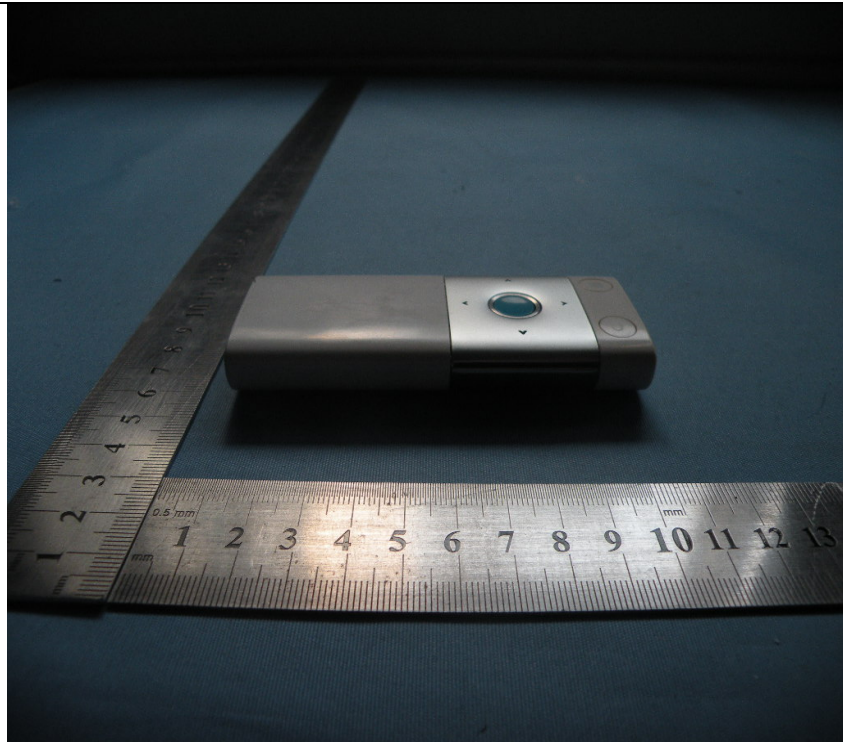

**Figure 6**

Photo of EUT

Front View [ ]

Rear View [ ]

Top View [ ]

Bottom View [ ]

Left View [ ]

Right View [  ]

Internal View [ ]

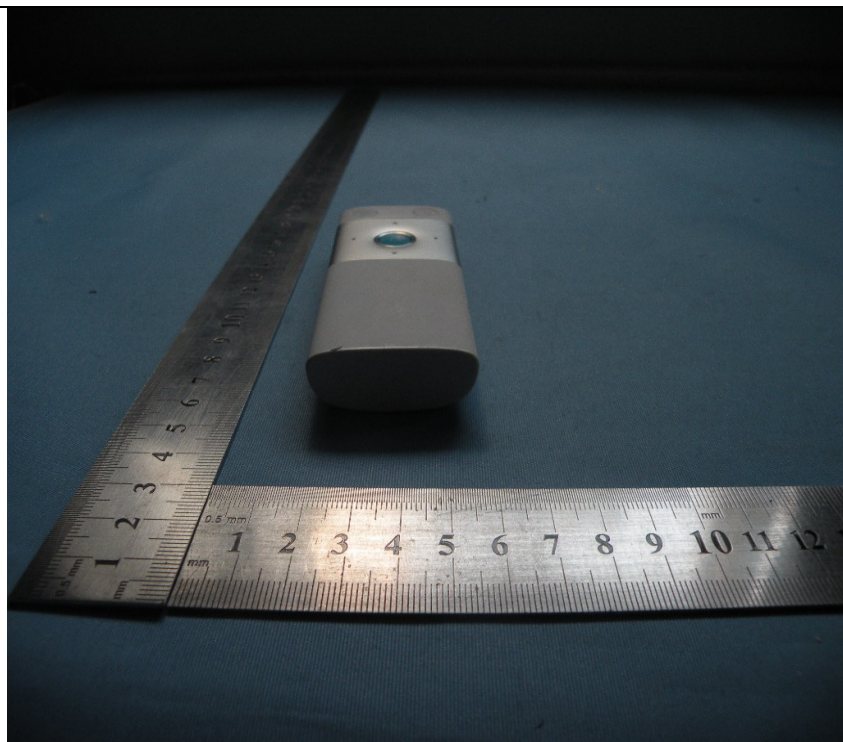

**Figure 7**

Photo of EUT

Front View [ ]

Rear View [ ]

Top View [ ]

Bottom View [ ]

Left View [ ]

Right View [ ]

Internal View [  ]

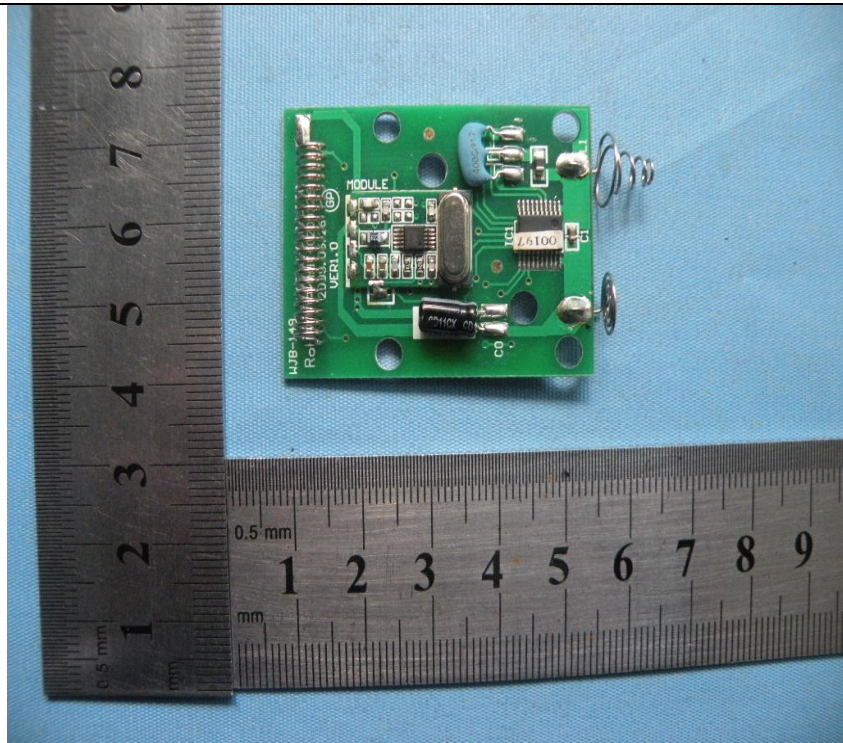

**Figure 8**

Photo of EUT

Front View [ ]

Rear View [ ]

Top View [ ]

Bottom View [ ]

Left View [ ]

Right View [ ]

Internal View [  ]

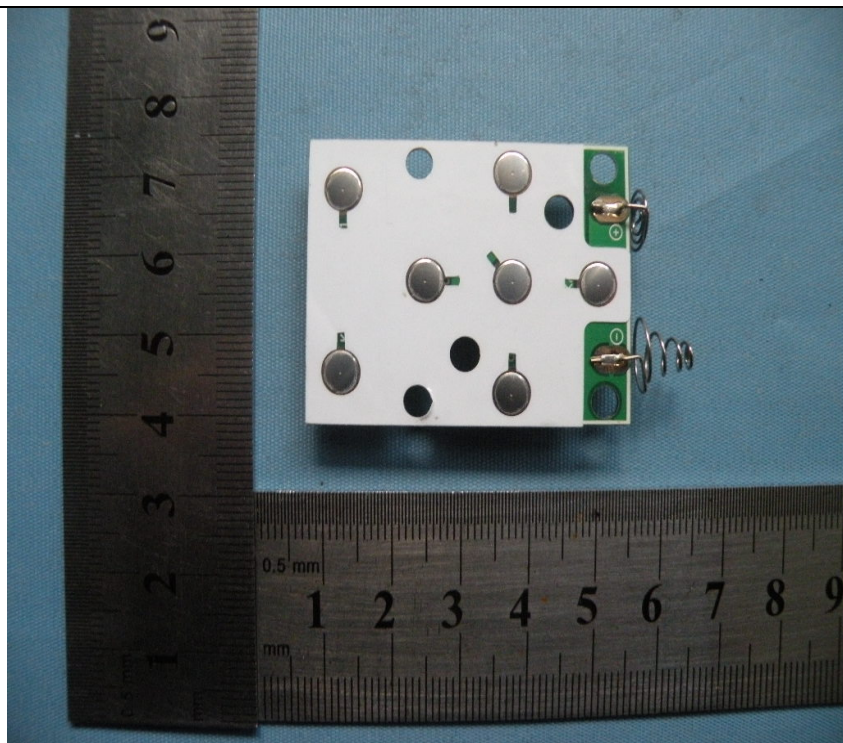

-----END OF THE REPORT-----