



# FCC TEST REPORT

**REPORT NO.:** RF110426E05

**MODEL NO.:** X3000

**FCC ID:** Q87-X3000

**RECEIVED:** Apr. 26, 2011

**TESTED:** May 06 to June 02, 2011

**ISSUED:** June 20, 2011

**APPLICANT:** Cisco Consumer Products LLC

**ADDRESS:** 121 Theory Drive, Irvine, CA 92617, USA

**ISSUED BY:** Bureau Veritas Consumer Products Services (H.K.)  
Ltd., Taoyuan Branch Hsin Chu Laboratory

**LAB ADDRESS :** No. 81-1, Lu Liao Keng, 9th Ling,Wu Lung Tsuen,  
Chiung Lin Hsiang, Hsin Chu Hsien 307, Taiwan

**TEST LOCATION (1):** No. 81-1, Lu Liao Keng, 9th Ling,Wu Lung Tsuen,  
Chiung Lin Hsiang, Hsin Chu Hsien 307, Taiwan

**TEST LOCATION (2):** No. 49, Ln. 206, Wende Rd., Shangshan Tsuen, Chiung  
Lin Hsiang, Hsin Chu Hsien 307, Taiwan

This test report consists of 83 pages in total. It may be duplicated completely for legal use with the approval of the applicant. It should not be reproduced except in full, without the written approval of our laboratory. The client should not use it to claim product certification, approval, or endorsement by TAF or any government agencies. The test results in the report only apply to the tested sample.





A D T

## Table of Contents

RELEASE CONTROL RECORD .....	4
1. CERTIFICATION .....	5
2. SUMMARY OF TEST RESULTS .....	6
2.1 MEASUREMENT UNCERTAINTY .....	7
3. GENERAL INFORMATION .....	8
3.1 GENERAL DESCRIPTION OF EUT .....	8
3.2 DESCRIPTION OF TEST MODES .....	10
3.2.1 TEST MODE APPLICABILITY AND TESTED CHANNEL DETAIL .....	10
3.3 GENERAL DESCRIPTION OF APPLIED STANDARDS .....	13
3.4 DESCRIPTION OF SUPPORT UNITS.....	14
3.5 CONFIGURATION OF SYSTEM UNDER TEST .....	15
4. TEST TYPES AND RESULTS .....	17
4.1 CONDUCTED EMISSION MEASUREMENT .....	17
4.1.1 LIMITS OF CONDUCTED EMISSION MEASUREMENT .....	17
4.1.2 TEST INSTRUMENTS.....	17
4.1.3 TEST PROCEDURES .....	18
4.1.4 DEVIATION FROM TEST STANDARD .....	18
4.1.5 TEST SETUP .....	19
4.1.6 EUT OPERATING CONDITIONS .....	19
4.1.7 TEST RESULTS (MODE 1) .....	20
4.1.8 TEST RESULTS (MODE 2) .....	22
4.2 RADIATED EMISSION MEASUREMENT .....	24
4.2.1 LIMITS OF RADIATED EMISSION MEASUREMENT .....	24
4.2.2 TEST INSTRUMENTS.....	25
4.2.3 TEST PROCEDURES .....	26
4.2.4 DEVIATION FROM TEST STANDARD .....	26
4.2.5 TEST SETUP .....	27
4.2.6 EUT OPERATING CONDITIONS .....	27
4.2.7 TEST RESULTS .....	28
4.3 6dB BANDWIDTH MEASUREMENT .....	57
4.3.1 LIMITS OF 6dB BANDWIDTH MEASUREMENT .....	57
4.3.2 TEST INSTRUMENTS.....	57
4.3.3 TEST PROCEDURE.....	57
4.3.4 DEVIATION FROM TEST STANDARD .....	57
4.3.5 TEST SETUP .....	57
4.3.6 EUT OPERATING CONDITIONS .....	57
4.3.7 TEST RESULTS .....	58
4.4 MAXIMUM PEAK OUTPUT POWER.....	62
4.4.1 LIMITS OF MAXIMUM PEAK OUTPUT POWER MEASUREMENT .....	62
4.4.2 INSTRUMENTS.....	62



A D T

4.4.3	TEST PROCEDURES .....	62
4.4.4	DEVIATION FROM TEST STANDARD .....	62
4.4.5	TEST SETUP .....	62
4.4.6	EUT OPERATING CONDITIONS .....	62
4.4.7	TEST RESULTS .....	63
4.5	POWER SPECTRAL DENSITY MEASUREMENT .....	64
4.5.1	LIMITS OF POWER SPECTRAL DENSITY MEASUREMENT .....	64
4.5.2	TEST INSTRUMENTS.....	64
4.5.3	TEST PROCEDURE.....	64
4.5.4	DEVIATION FROM TEST STANDARD.....	64
4.5.5	TEST SETUP .....	64
4.5.6	EUT OPERATING CONDITION.....	64
4.5.7	TEST RESULTS .....	65
4.6	CONDUCTED OUT-BAND EMISSION MEASUREMENT.....	69
4.6.1	LIMITS OF CONDUCTED OUT-BAND EMISSION MEASUREMENT.....	69
4.6.2	TEST INSTRUMENTS.....	69
4.6.3	TEST PROCEDURE.....	69
4.6.4	DEVIATION FROM TEST STANDARD.....	69
4.6.5	EUT OPERATING CONDITION.....	69
4.6.6	TEST RESULTS .....	69
5.	INFORMATION ON THE TESTING LABORATORIES .....	82
6.	APPENDIX A - MODIFICATIONS RECORDERS FOR ENGINEERING CHANGES TO THE EUT BY THE LAB.....	83



A D T

## RELEASE CONTROL RECORD

ISSUE NO.	REASON FOR CHANGE	DATE ISSUED
RF110426E05	Original release	June 20, 2011



A D T

## 1. CERTIFICATION

**PRODUCT:** Advanced Wireless ADSL2+ Modem Router  
**BRAND NAME:** Cisco  
**MODEL NO.:** X3000  
**TEST SAMPLE:** R&D SAMPLE  
**TESTED:** May 06 to June 02, 2011  
**APPLICANT:** Cisco Consumer Products LLC  
**STANDARDS:** FCC Part 15, Subpart C (Section 15.247)  
ANSI C63.4-2003  
ANSI C63.10-2009

The above equipment (Model: X3000) has been tested by **Bureau Veritas Consumer Products Services (H.K.) Ltd., Taoyuan Branch**, and found compliance with the requirement of the above standards. The test record, data evaluation & Equipment Under Test (EUT) configurations represented herein are true and accurate accounts of the measurements of the sample's EMC characteristics under the conditions specified in this report.

**PREPARED BY :**  , **DATE:** June 20, 2011  
( Claire Kuan, Specialist )

**APPROVED BY :**  , **DATE:** June 20, 2011  
( May Chen, Deputy Manager )

## 2. SUMMARY OF TEST RESULTS

The EUT has been tested according to the following specifications:

<b>APPLIED STANDARD: FCC Part 15, Subpart C</b>			
<b>Standard Section</b>	<b>Test Type and Limit</b>	<b>Result</b>	<b>Remark</b>
15.207	AC Power Conducted Emission	PASS	Meet the requirement of limit. Minimum passing margin is -11.37dB at 0.150MHz
15.247(a)(2)	Spectrum Bandwidth of a Direct Sequence Spread Spectrum System Limit: min. 500kHz	PASS	Meet the requirement of limit.
15.247(b)	Maximum Peak Output Power Limit: max. 30dBm	PASS	Meet the requirement of limit.
15.247(d)	Radiated Emissions Limit: Table 15.209	PASS	Meet the requirement of limit. Minimum passing margin is -1.0dB at 2483.50MHz
15.247(e)	Power Spectral Density Limit: max. 8dBm	PASS	Meet the requirement of limit.
15.247(d)	Conducted Out-Band Emission Measurement Limit: 20dB less than the peak value of fundamental frequency	PASS	Meet the requirement of limit.
15.203	Antenna Requirement	PASS	No antenna connector is used.



A D T

## 2.1 MEASUREMENT UNCERTAINTY

Where relevant, the following measurement uncertainty levels have been estimated for tests performed on the EUT as specified in CISPR 16-4-2:

This uncertainty represents an expanded uncertainty expressed at approximately the 95% confidence level using a coverage factor of  $k=2$ .

Measurement	Value
Conducted emissions	2.45 dB
Radiated emissions (30MHz-1GHz)	3.89 dB
Radiated emissions (1GHz -18GHz)	2.19 dB
Radiated emissions (18GHz -40GHz)	2.56 dB



A D T

### 3. GENERAL INFORMATION

#### 3.1 GENERAL DESCRIPTION OF EUT

<b>PRODUCT</b>	Advanced Wireless ADSL2+ Modem Router
<b>MODEL NO.</b>	X3000
<b>FCC ID</b>	Q87-X3000
<b>POWER SUPPLY</b>	DC 12V from power adapter
<b>MODULATION TYPE</b>	CCK, DQPSK, DBPSK for DSSS 64QAM, 16QAM, QPSK, BPSK for OFDM
<b>MODULATION TECHNOLOGY</b>	DSSS, OFDM
<b>TRANSFER RATE</b>	802.11b: 11 / 5.5 / 2 / 1Mbps 802.11g: 54 / 48 / 36 / 24 / 18 / 12 / 9 / 6Mbps 802.11n (20MHz, 400ns GI): 144.4 / 130 / 115.6 / 86.7 / 72.2 / 65.0 / 57.8 / 43.3 / 28.9 / 21.7 / 14.4 / 7.2Mbps 802.11n (40MHz, 400ns GI): 300.0 / 270.0 / 240.0 / 180.0 / 150.0 / 135.0 / 120.0 / 90.0 / 60.0 / 45.0 / 30.0 / 15.0Mbps
<b>FREQUENCY RANGE</b>	2412MHz ~ 2462MHz
<b>NUMBER OF CHANNEL</b>	11 for 802.11b, 802.11g, 802.11n (20MHz) 7 for 802.11n (40MHz)
<b>MAXIMUM OUTPUT POWER</b>	802.11b: 67.6mW 802.11g: 263.0mW 802.11n (20MHz): 583.5mW 802.11n (40MHz): 279.7mW
<b>ANTENNA TYPE</b>	Please see NOTE
<b>DATA CABLE</b>	NA
<b>I/O PORTS</b>	RJ45 x 1(WAN:10Mbps/100Mbps/1000Mbps) RJ45 x 4(Ethernet:10Mbps/100Mbps/1000Mbps) RJ11 x 1(DSL (Annex A)) USB x 1(Storage)
<b>ASSOCIATED DEVICES</b>	Adapter x 1

#### NOTE:

1. There are two antennas provided to this EUT, please refer to the following table:

Chain	Gain (Include cable loss)	Antenna Type	Cable Length
Chain (0)	3.6dBi	PIFA	200mm
Chain (1)	2.51dBi	PIFA	50mm



2. The EUT must be supplied with a power adapter and following six different model names could be chosen:

Adapter	Brand	Model No.	Spec.
Adapter 1	Bestec	NA0181WAA D	Input: 100-240V, 1A, 50/60Hz Output: 12Vdc, 1.5A DC output cable (unshielded, 1.6m)
Adapter 2	LEI	MU18-J120150-A1	Input: 100-240V, 0.6A, 50/60Hz Output: 12Vdc, 1.5A DC output cable (unshielded, 1.6m)

For radiated test , the EUT was pre-tested with above adapters, the worse case was found in **Adapter 1**. Therefore only the test data of the adapter was recorded in this report.

3. The EUT was pre-tested under the following test modes for two different axes placements:

Test Mode	Description
Mode A	Level-set (Put on tabletop)
Mode B	Tower-set (Wall-mounted)

From the above modes, the worst emission level was found in Mode A. Therefore only the test data of the modes were recorded in this report individually.

4. The EUT is 2 \* 2 spatial MIMO (2Tx & 2Rx) without beam forming function. The 11b and 11g legacy mode is limited to single transmitter only.
5. When the EUT operating in 802.11n, the software operation, which is defined by manufacturer, MCS (Modulation and Coding Schemes) from 0 to 15.
6. The above EUT information was declared by manufacturer and for more detailed features description, please refer to the manufacturer's specifications or user's manual.



A D T

### 3.2 DESCRIPTION OF TEST MODES

Eleven channels are provided for 802.11b, 802.11g, 802.11n (20MHz):

CHANNEL	FREQUENCY	CHANNEL	FREQUENCY
1	2412MHz	7	2442MHz
2	2417MHz	8	2447MHz
3	2422MHz	9	2452MHz
4	2427MHz	10	2457MHz
5	2432MHz	11	2462MHz
6	2437MHz		

Seven channels are provided for 802.11n (40MHz):

CHANNEL	FREQUENCY	CHANNEL	FREQUENCY
3	2422MHz	7	2442MHz
4	2427MHz	8	2447MHz
5	2432MHz	9	2452MHz
6	2437MHz		

#### 3.2.1 TEST MODE APPLICABILITY AND TESTED CHANNEL DETAIL

EUT CONFIGURE MODE	APPLICABLE TO				DESCRIPTION
	PLC	RE < 1G	RE <sup>≥</sup> 1G	APCM	
MODE 1	√	√	√	√	With adapter 1
MODE 2	√	-	-	-	With adapter 2

Where **PLC**: Power Line Conducted Emission

**RE < 1G**: Radiated Emission below 1GHz

**RE <sup>≥</sup> 1G**: Radiated Emission above 1GHz

**APCM**: Antenna Port Conducted Measurement



A D T

**ANTENNA COMBINATION MODE:**

COMBINATION MODE	OPERATION MODE	TX CHAIN(0)	TX CHAIN(1)
A	802.11 b	√	
B	802.11 b		√
C	802.11 g	√	
D	802.11 g		√
E	802.11n(20MHz) for MCS0~7	√	
F	802.11n(20MHz) for MCS0~7		√
G	802.11n(20MHz) for MCS8~15	√	√
H	802.11n(40MHz) for MCS0~7	√	
I	802.11n(40MHz) for MCS0~7		√
J	802.11n(40MHz) for MCS8~15	√	√

Note:

1. The above information was declared by manufacturer and for more detailed features description, please refer to the manufacturer's specifications or user's manual.
2. Mode A, C, G, and J the worst modes, were selected as representative mode for the report.

**POWER LINE CONDUCTED EMISSION TEST:**

- Pre-Scan has been conducted to determine the worst-case mode from all possible combinations between available modulations, data rates and antenna ports (if EUT with antenna diversity architecture).
- Following channel(s) was (were) selected for the final test as listed below.

MODE	AVAILABLE CHANNEL	TESTED CHANNEL	MODULATION TECHNOLOGY	MODULATION TYPE	DATA RATE (Mbps)	COMBINATION
802.11n (20MHz)	1 to 11	6	OFDM	BPSK	14.44	G

**RADIATED EMISSION TEST (BELOW 1 GHz):**

- Pre-Scan has been conducted to determine the worst-case mode from all possible combinations between available modulations, data rates and antenna ports (if EUT with antenna diversity architecture).
- Following channel(s) was (were) selected for the final test as listed below.

MODE	AVAILABLE CHANNEL	TESTED CHANNEL	MODULATION TECHNOLOGY	MODULATION TYPE	DATA RATE (Mbps)	COMBINATION
802.11n (20MHz)	1 to 11	6	OFDM	BPSK	14.4	G



A D T

**RADIATED EMISSION TEST (ABOVE 1 GHz):**

- Pre-Scan has been conducted to determine the worst-case mode from all possible combinations between available modulations, data rates and antenna ports (if EUT with antenna diversity architecture).
- Following channel(s) was (were) selected for the final test as listed below.

MODE	AVAILABLE CHANNEL	TESTED CHANNEL	MODULATION TECHNOLOGY	MODULATION TYPE	DATA RATE (Mbps)	COMBINATION
802.11b	1 to 11	1, 6, 11	DSSS	DBPSK	1	A
802.11g	1 to 11	1, 6, 11	OFDM	BPSK	6	C
802.11n (20MHz)	1 to 11	1, 6, 11	OFDM	BPSK	14.4	G
802.11n (40MHz)	3 to 9	3, 6, 9	OFDM	BPSK	30	J

**CONDUCTED OUT-BAND EMISSION MEASUREMENT:**

- Pre-Scan has been conducted to determine the worst-case mode from all possible combinations between available modulations, data rates and antenna ports (if EUT with antenna diversity architecture).
- Following channel(s) was (were) selected for the final test as listed below.

MODE	AVAILABLE CHANNEL	TESTED CHANNEL	MODULATION TECHNOLOGY	MODULATION TYPE	DATA RATE (Mbps)	COMBINATION
802.11b	1 to 11	1, 11	DSSS	DBPSK	1	A
802.11g	1 to 11	1, 11	OFDM	BPSK	6	C
802.11n (20MHz)	1 to 11	1, 11	OFDM	BPSK	14.4	G
802.11n (40MHz)	3 to 9	3, 9	OFDM	BPSK	30	J

- ※ Conducted out band emission as show worst chain in report base on preliminary measurement.



A D T

**ANTENNA PORT CONDUCTED MEASUREMENT:**

- This item includes all test value of each mode, but only includes spectrum plot of worst value of each mode.
- Pre-Scan has been conducted to determine the worst-case mode from all possible combinations between available modulations, data rates and antenna ports (if EUT with antenna diversity architecture).
- Following channel(s) was (were) selected for the final test as listed below.

MODE	AVAILABLE CHANNEL	TESTED CHANNEL	MODULATION TECHNOLOGY	MODULATION TYPE	DATA RATE (Mbps)	COMBINATION
802.11b	1 to 11	1, 6, 11	DSSS	DBPSK	1	A
802.11g	1 to 11	1, 6, 11	OFDM	BPSK	6	C
802.11n (20MHz)	1 to 11	1, 6, 11	OFDM	BPSK	14.4	G
802.11n (40MHz)	3 to 9	3, 6, 9	OFDM	BPSK	30	J

※ Bandwidth as show worst chain in report base on preliminary measurement.

**TEST CONDITION:**

APPLICABLE TO	ENVIRONMENTAL CONDITIONS	INPUT POWER	TESTED BY
RE <sup>3</sup> 1G	25deg. C, 65%RH, 1003 hPa	120Vac, 60Hz	Frank Liu
RE<1G	20deg. C, 65%RH, 1003 hPa	120Vac, 60Hz	Frank Liu
PLC	25deg. C, 64%RH, 1003 hPa	120Vac, 60Hz	Timmy Hu
APCM	25deg. C, 60%RH, 1003 hPa	120Vac, 60Hz	Frank Liu

**3.3 GENERAL DESCRIPTION OF APPLIED STANDARDS**

The EUT is a RF product. According to the specifications of the manufacturer, it must comply with the requirements of the following standards:

**FCC Part 15, Subpart C. (15.247)**

**ANSI C63.4-2003**

**ANSI C63.10-2009**

All test items have been performed and recorded as per the above standards.

**NOTE:** The EUT has been verified to comply with the requirements of FCC Part 15, Subpart B, Class B (DoC). The test report has been issued separately.

### 3.4 DESCRIPTION OF SUPPORT UNITS

The EUT has been tested as an independent unit together with other necessary accessories or support units. The following support units or accessories were used to form a representative test configuration during the tests.

No.	Product	Brand	Model No.	Serial No.	FCC ID
1	NOTEBOOK COMPUTER	DELL	PP32LA	DSL32S	FCC DoC
2	NOTEBOOK COMPUTER	DELL	PP27L	7YLB32S	FCC DoC
3	iPod shuffle	Apple	MC749TA/A	CC4DMFJUFDMD	NA
	USB Flash disk (For Conducted Emission )	SanDisk	SDCZ2-512	5675968612	FCC DoC
4	HUB	ZyXEL	ES-116P	S060H02000215	FCC DoC
5	CO-ROUTER	ZyXEL	IES-1000	S08024701597	FCC DoC

No.	SIGNAL CABLE DESCRIPTION OF THE ABOVE SUPPORT UNITS
1	UTP cable, 10m
2	UTP cable, 10m
3	USB Cable W/O Core ,0.1m
	NA
4	UTP cable, 10m
5	RJ-11 cable, 10m

**NOTE:** 1. All power cords of the above support units are non shielded (1.8m).

### 3.5 CONFIGURATION OF SYSTEM UNDER TEST

For Conducted Emission test:

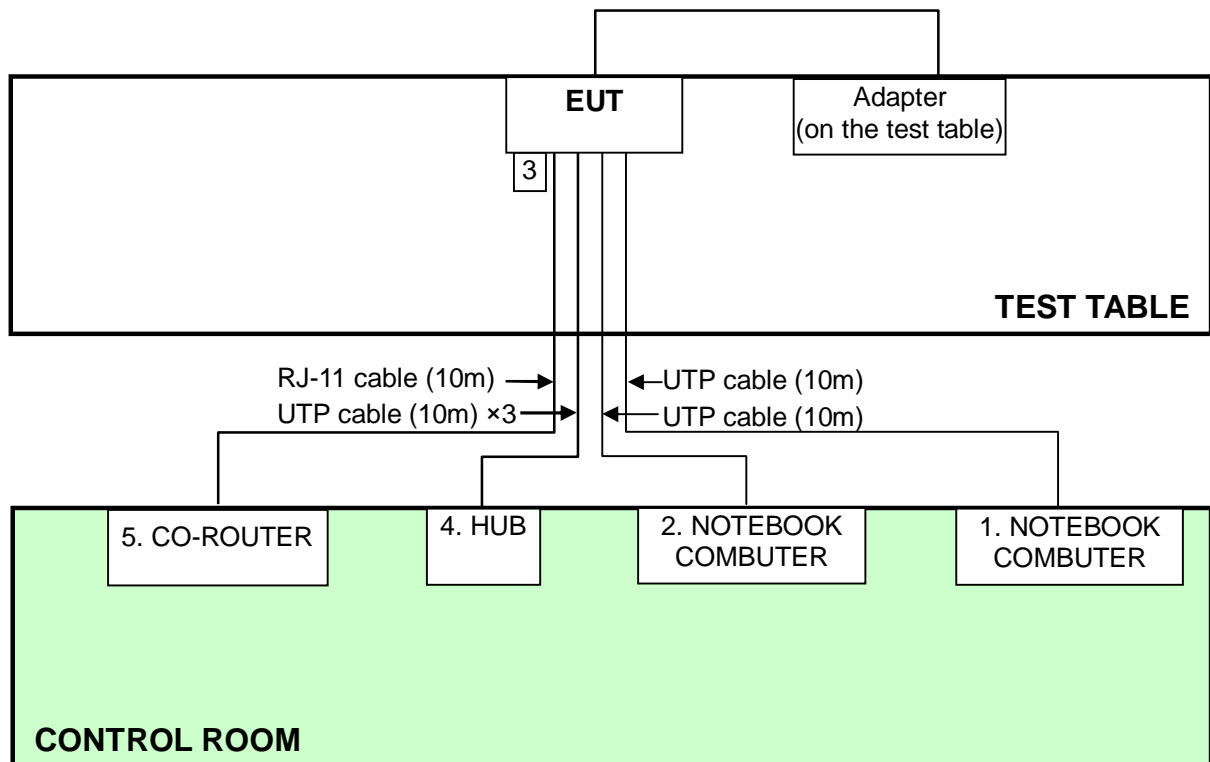

**NOTE:** 1. The support units 3 is USB Flash Drive.

**For other test items:**

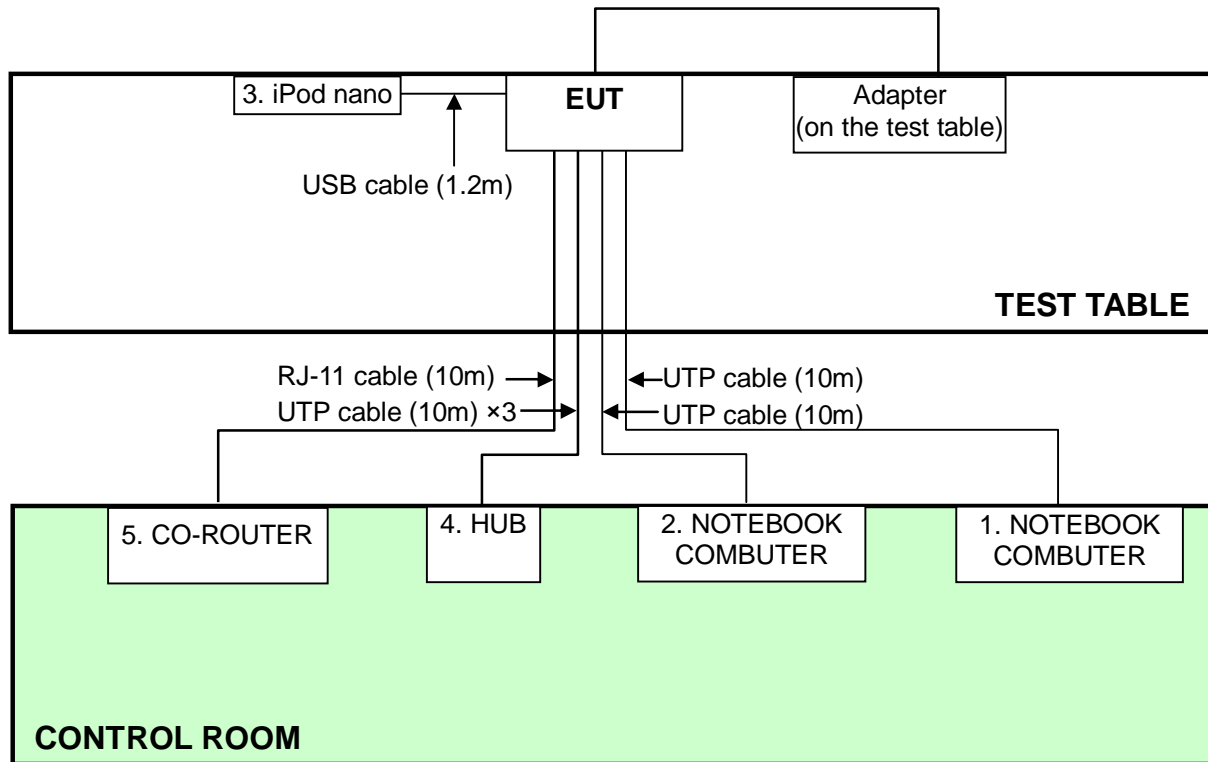





A D T

## 4. TEST TYPES AND RESULTS

### 4.1 CONDUCTED EMISSION MEASUREMENT

#### 4.1.1 LIMITS OF CONDUCTED EMISSION MEASUREMENT

FREQUENCY OF EMISSION (MHz)	CONDUCTED LIMIT (dB $\mu$ V)	
	Quasi-peak	Average
0.15-0.5	66 to 56	56 to 46
0.5-5	56	46
5-30	60	50

- NOTE:**
1. The lower limit shall apply at the transition frequencies.
  2. The limit decreases in line with the logarithm of the frequency in the range of 0.15 to 0.50 MHz.
  3. All emanations from a class A/B digital device or system, including any network of conductors and apparatus connected thereto, shall not exceed the level of field strengths specified above.

#### 4.1.2 TEST INSTRUMENTS

DESCRIPTION & MANUFACTURER	MODEL NO.	SERIAL NO.	CALIBRATED DATE	CALIBRATED UNTIL
ROHDE & SCHWARZ Test Receiver	ESCS 30	100287	Mar. 02, 2011	Mar. 01, 2012
Line-Impedance Stabilization Network (for EUT)	NSLK 8127	8127-523	Sep. 17, 2010	Sep. 16, 2011
Line-Impedance Stabilization Network (for Peripheral)	ENV-216	100072	June 11, 2010	June 10, 2011
RF Cable (JYEBAO)	5DFB	CONCAB-003	Aug. 06, 2010	Aug. 05, 2011
50 ohms Terminator	50	3	Nov. 03, 2010	Nov. 02, 2011
Software	BV ADT_Cond_V7.3.7	NA	NA	NA

**Note:**

1. The calibration interval of the above test instruments is 12 months and the calibrations are traceable to NML/ROC and NIST/USA.
2. The test was performed in Shielded Room No. A.
3. The VCCI Con A Registration No. is C-817.

#### 4.1.3 TEST PROCEDURES

- a. The EUT was placed 0.4 meters from the conducting wall of the shielded room with EUT being connected to the power mains through a line impedance stabilization network (LISN). Other support units were connected to the power mains through another LISN. The two LISNs provide 50 ohm/ 50uH of coupling impedance for the measuring instrument.
- b. Both lines of the power mains connected to the EUT were checked for maximum conducted interference.
- c. The frequency range from 150kHz to 30MHz was searched. Emission levels under (Limit - 20dB) were not recorded.

#### 4.1.4 DEVIATION FROM TEST STANDARD

No deviation

#### 4.1.5 TEST SETUP

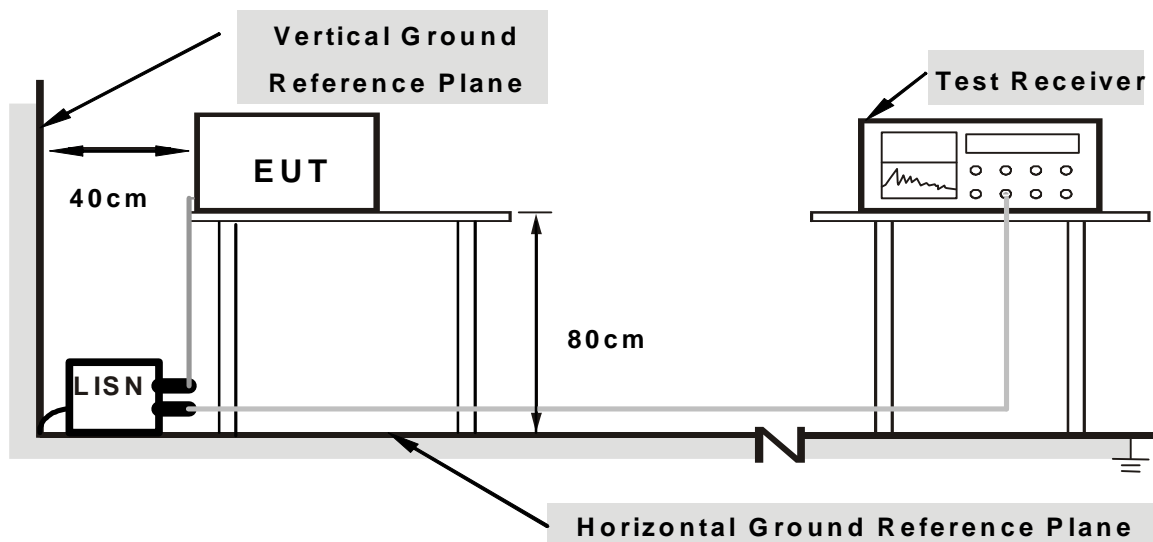

**Note: 1. Support units were connected to second LISN.**

**2. Both of LISNs (AMN) are 80 cm from EUT and at least 80 from other units and other metal planes**

For the actual test configuration, please refer to the related item – Photographs of the Test Configuration.

#### 4.1.6 EUT OPERATING CONDITIONS

1. Turned on the power of all equipment.
2. Prepared other computer system support unit 1 (Notebook Computer) to act as communication partner and placed it outside of testing area.
3. The communication partner ran test program “Broadcom command” to enable EUT under transmission/receiving condition continuously via one UTP cable.

### 4.1.7 TEST RESULTS (MODE 1)

<b>PHASE</b>	Line (L)	<b>6dB BANDWIDTH</b>	9 kHz
--------------	----------	----------------------	-------

No	Freq. [MHz]	Corr. Factor (dB)	Reading Value [dB (uV)]		Emission Level [dB (uV)]		Limit [dB (uV)]		Margin (dB)	
			Q.P.	AV.	Q.P.	AV.	Q.P.	AV.	Q.P.	AV.
			1	0.162	0.36	51.86	-	52.22	-	65.37
2	0.197	0.36	46.83	-	47.19	-	63.74	53.74	-16.55	-
3	0.255	0.36	41.75	-	42.11	-	61.58	51.58	-19.47	-
4	0.291	0.36	39.34	-	39.70	-	60.51	50.51	-20.81	-
5	17.094	1.02	25.46	-	26.48	-	60.00	50.00	-33.52	-
6	21.762	1.12	25.38	-	26.50	-	60.00	50.00	-33.50	-

- REMARKS:**
1. Q.P. and AV. are abbreviations of quasi-peak and average individually.
  2. "-": The Quasi-peak reading value also meets average limit and measurement with the average detector is unnecessary.
  3. The emission levels of other frequencies were very low against the limit.
  4. Margin value = Emission level - Limit value
  5. Correction factor = Insertion loss + Cable loss
  6. Emission Level = Correction Factor + Reading Value.

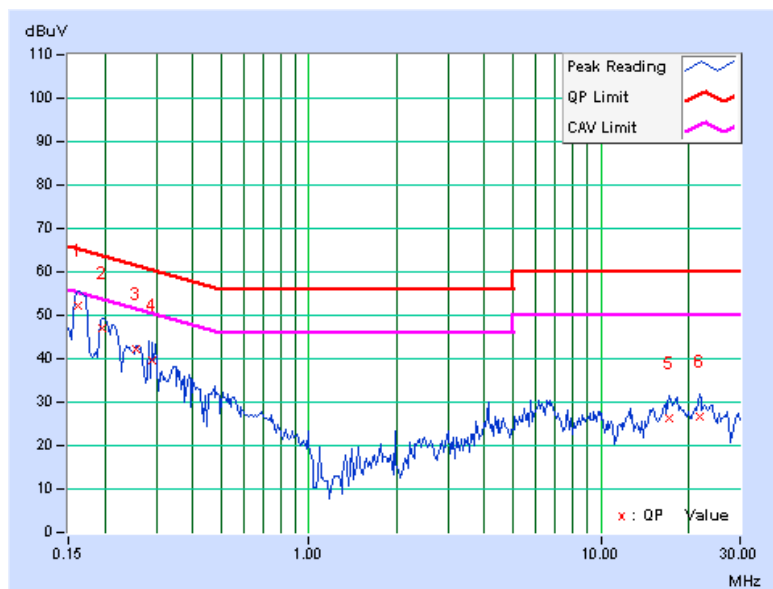

<b>PHASE</b>	Neutral (N)	<b>6dB BANDWIDTH</b>	9 kHz
--------------	-------------	----------------------	-------

No	Freq. [MHz]	Corr. Factor (dB)	Reading Value [dB (uV)]		Emission Level [dB (uV)]		Limit [dB (uV)]		Margin (dB)	
			Q.P.	AV.	Q.P.	AV.	Q.P.	AV.	Q.P.	AV.
			1	0.154	0.10	51.25	-	51.35	-	65.78
2	0.197	0.10	46.38	-	46.48	-	63.74	53.74	-17.26	-
3	0.291	0.10	38.79	-	38.89	-	60.51	50.51	-21.61	-
4	0.353	0.11	34.11	-	34.22	-	58.89	48.89	-24.67	-
5	6.262	0.33	29.11	-	29.44	-	60.00	50.00	-30.56	-
6	12.895	0.75	27.16	-	27.91	-	60.00	50.00	-32.09	-

- REMARKS:**
1. Q.P. and AV. are abbreviations of quasi-peak and average individually.
  2. "-": The Quasi-peak reading value also meets average limit and measurement with the average detector is unnecessary.
  3. The emission levels of other frequencies were very low against the limit.
  4. Margin value = Emission level - Limit value
  5. Correction factor = Insertion loss + Cable loss
  6. Emission Level = Correction Factor + Reading Value.

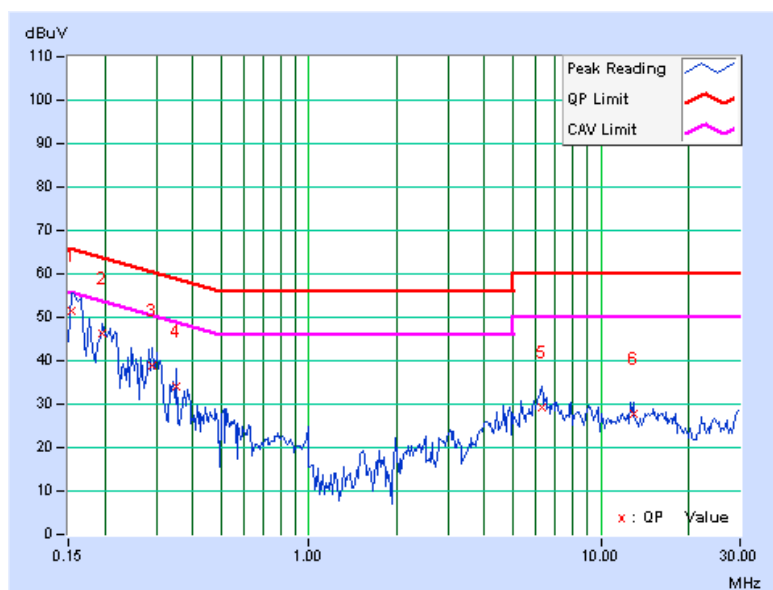

### 4.1.8 TEST RESULTS (MODE 2)

<b>PHASE</b>	Line (L)	<b>6dB BANDWIDTH</b>	9 kHz
--------------	----------	----------------------	-------

No	Freq. [MHz]	Corr. Factor (dB)	Reading Value [dB (uV)]		Emission Level [dB (uV)]		Limit [dB (uV)]		Margin (dB)	
			Q.P.	AV.	Q.P.	AV.	Q.P.	AV.	Q.P.	AV.
1	0.154	0.36	52.22	-	52.58	-	65.79	55.79	-13.20	-
2	0.173	0.36	48.77	-	49.13	-	64.79	54.79	-15.66	-
3	0.224	0.36	41.73	-	42.09	-	62.66	52.66	-20.57	-
4	0.466	0.37	27.45	-	27.82	-	56.58	46.58	-28.76	-
5	1.973	0.46	31.56	-	32.02	-	56.00	46.00	-23.98	-
6	12.625	0.85	23.25	-	24.10	-	60.00	50.00	-35.90	-

- REMARKS:**
1. Q.P. and AV. are abbreviations of quasi-peak and average individually.
  2. "-": The Quasi-peak reading value also meets average limit and measurement with the average detector is unnecessary.
  3. The emission levels of other frequencies were very low against the limit.
  4. Margin value = Emission level - Limit value
  5. Correction factor = Insertion loss + Cable loss
  6. Emission Level = Correction Factor + Reading Value.

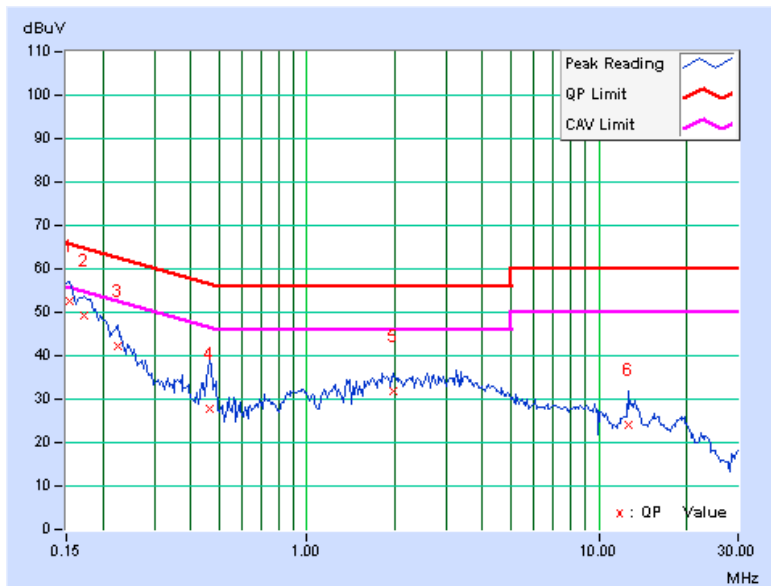

<b>PHASE</b>	Neutral (N)	<b>6dB BANDWIDTH</b>	9 kHz
--------------	-------------	----------------------	-------

No	Freq.	Corr.	Reading Value		Emission Level		Limit		Margin	
	[MHz]	Factor	[dB (uV)]	[dB (uV)]	[dB (uV)]	[dB (uV)]	[dB (uV)]	[dB (uV)]	[dB (uV)]	[dB (uV)]
		(dB)	Q.P.	AV.	Q.P.	AV.	Q.P.	AV.	Q.P.	AV.
1	0.150	0.10	54.53	-	54.63	-	66.00	56.00	-11.37	-
2	0.173	0.10	51.46	-	51.56	-	64.79	54.79	-13.24	-
3	0.365	0.11	33.79	-	33.90	-	58.62	48.62	-24.72	-
4	0.470	0.12	37.88	-	38.00	-	56.51	46.51	-18.51	-
5	2.531	0.21	31.99	-	32.20	-	56.00	46.00	-23.80	-
6	13.256	0.78	28.67	-	29.45	-	60.00	50.00	-30.55	-

- REMARKS:**
1. Q.P. and AV. are abbreviations of quasi-peak and average individually.
  2. "-": The Quasi-peak reading value also meets average limit and measurement with the average detector is unnecessary.
  3. The emission levels of other frequencies were very low against the limit.
  4. Margin value = Emission level - Limit value
  5. Correction factor = Insertion loss + Cable loss
  6. Emission Level = Correction Factor + Reading Value.

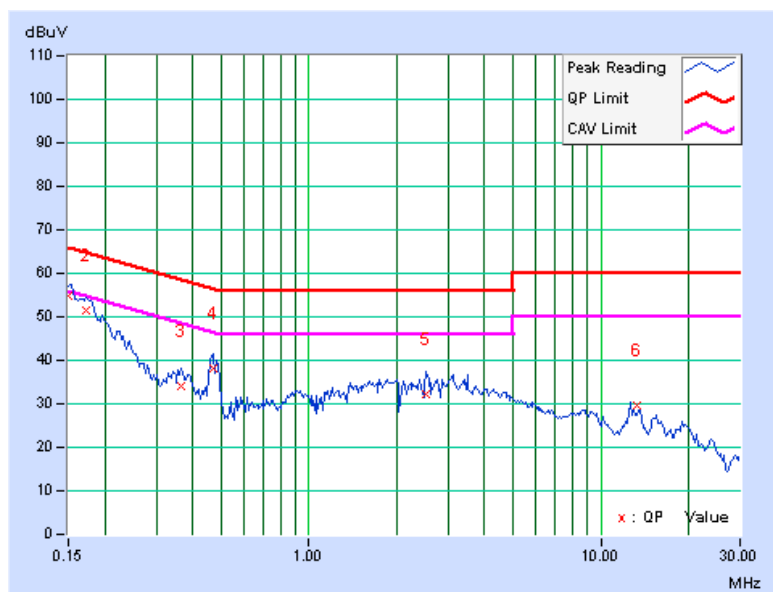

## 4.2 RADIATED EMISSION MEASUREMENT

### 4.2.1 LIMITS OF RADIATED EMISSION MEASUREMENT

Emissions radiated outside of the specified bands, shall be according to the general radiated limits in 15.209 as following:

Frequencies (MHz)	Field strength (microvolts/meter)	Measurement distance (meters)
0.009-0.490	2400/F(kHz)	300
0.490-1.705	24000/F(kHz)	30
1.705-30.0	30	30
30-88	100	3
88-216	150	3
216-960	200	3
Above 960	500	3

**NOTE:**

1. The lower limit shall apply at the transition frequencies.
2. Emission level (dBuV/m) = 20 log Emission level (uV/m).
3. As shown in 15.35(b), for frequencies above 1000MHz, the field strength limits are based on average detector, however, the peak field strength of any emission shall not exceed the maximum permitted average limits, specified above by more than 20dB under any condition of modulation.
4. Section 15.205 restricted bands of operation shall compliance with the limits in Section 15.209.





A D T

#### 4.2.2 TEST INSTRUMENTS

DESCRIPTION & MANUFACTURER	MODEL NO.	SERIAL NO.	CALIBRATED DATE	CALIBRATED UNTIL
Agilent Spectrum Analyzer	E4446A	MY48250253	Aug. 23, 2010	Aug. 22, 2011
Agilent Pre-Selector	N9039A	MY46520310	Aug. 23, 2010	Aug. 22, 2011
Agilent Signal Generator	N5181A	MY49060347	July 30, 2010	July 29, 2011
LIG NEX1 Test Receiver	ER-265	L09068005	Oct. 25, 2010	Oct. 24, 2011
Mini-Circuits Pre-Amplifier	ZFL-1000VH2B	AMP-ZFL-04	Nov. 16, 2010	Nov. 15, 2011
Agilent Pre-Amplifier	8449B	3008A02465	Feb. 28, 2011	Feb. 27, 2012
Miteq Pre-Amplifier	AFS33-1800265 0-30-8P-44	881786	NA	NA
SCHWARZBECK Trilog Broadband Antenna	VULB 9168	9168-361	Apr. 14, 2011	Apr. 14, 2012
AISI Horn_Antenna	AIH.8018	000022009111 0	Nov. 22, 2010	Nov. 21, 2011
SCHWARZBECK Horn_Antenna	BBHA 9170	9170-424	Oct. 08, 2010	Oct. 07, 2011
RF CABLE	NA	RF104-205 RF104-207 RF104-202	Dec. 28, 2010	Dec. 27, 2011
RF Cable	NA	CHHCAB_001	NA	NA
Software	ADT_Radiated_V8.7.05	NA	NA	NA
CT Antenna Tower & Turn Table	NA	NA	NA	NA

- Note: 1. The calibration interval of the above test instruments is 12 months and the calibrations are traceable to NML/ROC and NIST/USA.  
2. The horn antenna, preamplifier (model: 8449B) are used only for the measurement of emission frequency above 1GHz if tested.  
3. The test was performed in 966 Chamber No. H.  
4. The FCC Site Registration No. is 797305.  
5. The CANADA Site Registration No. is IC 7450H-3.

### 4.2.3 TEST PROCEDURES

- a. The EUT was placed on the top of a rotating table 0.8 meters above the ground at 3 meters chamber room. The table was rotated 360 degrees to determine the position of the highest radiation.
- b. The EUT was set 3 meters away from the interference-receiving antenna, which was mounted on the top of a variable-height antenna tower.
- c. The height of antenna is varied from one meter to four meters above the ground to determine the maximum value of the field strength. Both horizontal and vertical polarizations of the antenna are set to make the measurement.
- d. For each suspected emission, the EUT was arranged to its worst case and then the antenna was tuned to heights from 1 meter to 4 meters and the rotatable table was turned from 0 degrees to 360 degrees to find the maximum reading.
- e. The test-receiver system was set to quasi-peak detect function and specified bandwidth with maximum hold mode when the test frequency is below 1 GHz.
- f. The test-receiver system was set to peak and average detect function and specified bandwidth with maximum hold mode when the test frequency is above 1 GHz. If the peak reading value also meets average limit, measurement with the average detector is unnecessary.

**NOTE:**

1. The resolution bandwidth and video bandwidth of test receiver/spectrum analyzer is 120kHz for Quasi-peak detection (QP) at frequency below 1GHz.
2. The resolution bandwidth of test receiver/spectrum analyzer is 1 MHz and video bandwidth is 3MHz for Peak detection at frequency above 1GHz.
3. The resolution bandwidth of test receiver/spectrum analyzer is 1MHz and the video bandwidth is 10Hz for Average detection (AV) at frequency above 1GHz.

### 4.2.4 DEVIATION FROM TEST STANDARD

No deviation

#### 4.2.5 TEST SETUP

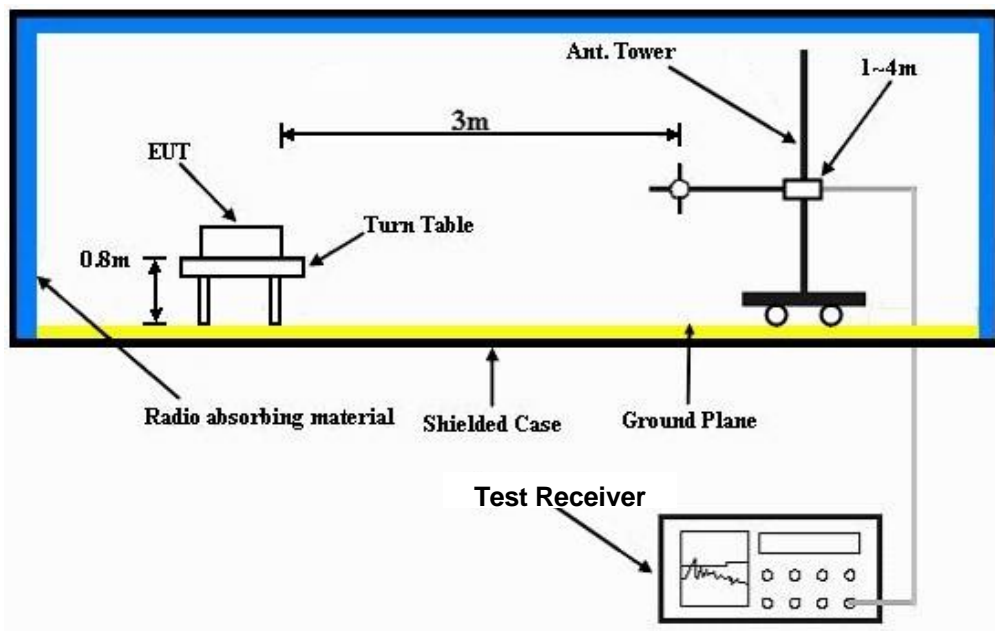

For the actual test configuration, please refer to the related item – Photographs of the Test Configuration.

#### 4.2.6 EUT OPERATING CONDITIONS

4. Turned on the power of all equipment.
5. Prepared other computer system support unit 1 (Notebook Computer) to act as communication partner and placed it outside of testing area.
6. The communication partner ran test program “Broadcom command” to enable EUT under transmission/receiving condition continuously via one UTP cable.



A D T

## 4.2.7 TEST RESULTS

## BELOW 1GHz WORST-CASE DATA : 802.11n (20MHz) OFDM MODULATION

EUT TEST CONDITION		MEASUREMENT DETAIL	
CHANNEL	Channel 6	FREQUENCY RANGE	Below 1000MHz
INPUT POWER	120V / 60Hz	DETECTOR FUNCTION	Quasi-Peak
ENVIRONMENTAL CONDITIONS	20deg. C, 65%RH 1003 hPa	TESTED BY	Frank Liu

ANTENNA POLARITY & TEST DISTANCE: HORIZONTAL AT 3 M								
NO.	FREQ. (MHz)	EMISSION LEVEL (dBuV/m)	LIMIT (dBuV/m)	MARGIN (dB)	ANTENNA HEIGHT (m)	TABLE ANGLE (Degree)	RAW VALUE (dBuV)	CORRECTION FACTOR (dB/m)
1	207.40	38.9 QP	43.5	-4.6	1.50 H	0	27.45	11.43
2	374.97	35.9 QP	46.0	-10.1	1.00 H	37	18.73	17.13
3	500.02	36.5 QP	46.0	-9.5	1.50 H	338	16.58	19.96
4	624.96	42.9 QP	46.0	-3.1	1.50 H	334	20.39	22.53
5	750.01	40.2 QP	46.0	-5.8	1.00 H	337	16.27	23.92
6	874.95	39.9 QP	46.0	-6.1	1.00 H	360	13.75	26.14
ANTENNA POLARITY & TEST DISTANCE: VERTICAL AT 3 M								
NO.	FREQ. (MHz)	EMISSION LEVEL (dBuV/m)	LIMIT (dBuV/m)	MARGIN (dB)	ANTENNA HEIGHT (m)	TABLE ANGLE (Degree)	RAW VALUE (dBuV)	CORRECTION FACTOR (dB/m)
1	51.31	36.2 QP	40.0	-3.8	1.00 V	241	22.19	13.99
2	62.57	38.8 QP	40.0	-1.2	1.50 V	260	25.99	12.85
3	195.91	39.0 QP	43.5	-4.5	1.00 V	360	27.55	11.48
4	374.97	34.1 QP	46.0	-12.0	1.00 V	13	16.92	17.13
5	624.96	41.1 QP	46.0	-4.9	1.50 V	354	18.61	22.53
6	875.06	38.8 QP	46.0	-7.3	1.50 V	350	12.61	26.14

- REMARKS:**
1. Emission level (dBuV/m) = Raw Value (dBuV) + Correction Factor (dB/m).
  2. Correction Factor (dB/m) = Antenna Factor (dB/m) + Cable Factor (dB).
  3. The other emission levels were very low against the limit.
  4. Margin value = Emission level – Limit value.



## ABOVE 1GHz WORST-CASE DATA

### 802.11b DSSS MODULATION

EUT TEST CONDITION		MEASUREMENT DETAIL	
CHANNEL	Channel 1	FREQUENCY RANGE	1 ~ 25GHz
INPUT POWER	120V / 60Hz	DETECTOR FUNCTION	Peak (PK) Average (AV)
ENVIRONMENTAL CONDITIONS	25deg. C, 65%RH 1003 hPa	TESTED BY	Frank Liu

ANTENNA POLARITY & TEST DISTANCE: HORIZONTAL AT 3 M								
NO.	FREQ. (MHz)	EMISSION LEVEL (dBuV/m)	LIMIT (dBuV/m)	MARGIN (dB)	ANTENNA HEIGHT (m)	TABLE ANGLE (Degree)	RAW VALUE (dBuV)	CORRECTION FACTOR (dB/m)
1	2390.00	61.2 PK	74.0	-12.8	1.00 H	251	29.99	31.21
2	2390.00	50.8 AV	54.0	-3.2	1.00 H	251	19.59	31.21
3	*2412.00	111.1 PK			1.00 H	251	79.83	31.27
4	*2412.00	108.3 AV			1.00 H	251	77.03	31.27
5	4824.00	54.4 PK	74.0	-19.6	1.18 H	81	14.98	39.42
6	4824.00	51.6 AV	54.0	-2.4	1.18 H	81	12.18	39.42
ANTENNA POLARITY & TEST DISTANCE: VERTICAL AT 3 M								
NO.	FREQ. (MHz)	EMISSION LEVEL (dBuV/m)	LIMIT (dBuV/m)	MARGIN (dB)	ANTENNA HEIGHT (m)	TABLE ANGLE (Degree)	RAW VALUE (dBuV)	CORRECTION FACTOR (dB/m)
1	2333.30	54.9 PK	74.0	-19.1	1.67 V	8	23.84	31.06
2	2333.30	44.0 AV	54.0	-10	1.67 V	8	12.94	31.06
3	*2412.00	96.5 PK			1.67 V	8	65.23	31.27
4	*2412.00	94.2 AV			1.67 V	8	62.93	31.27
5	4824.00	55.4 PK	74.0	-18.6	1.00 V	188	15.98	39.42
6	4824.00	52.7 AV	54.0	-1.3	1.00 V	188	13.28	39.42

- REMARKS:**
1. Emission level (dBuV/m) = Raw Value (dBuV) + Correction Factor (dB/m).
  2. Correction Factor (dB/m) = Antenna Factor (dB/m) + Cable Factor (dB).
  3. The other emission levels were very low against the limit.
  4. Margin value = Emission level – Limit value.
  5. “ \* “: Fundamental frequency.



A D T

EUT TEST CONDITION		MEASUREMENT DETAIL	
CHANNEL	Channel 6	FREQUENCY RANGE	1 ~ 25GHz
INPUT POWER	120V / 60Hz	DETECTOR FUNCTION	Peak (PK) Average (AV)
ENVIRONMENTAL CONDITIONS	25deg. C, 65%RH 1003 hPa	TESTED BY	Frank Liu

ANTENNA POLARITY & TEST DISTANCE: HORIZONTAL AT 3 M								
NO.	FREQ. (MHz)	EMISSION LEVEL (dBuV/m)	LIMIT (dBuV/m)	MARGIN (dB)	ANTENNA HEIGHT (m)	TABLE ANGLE (Degree)	RAW VALUE (dBuV)	CORRECTION FACTOR (dB/m)
1	*2437.00	110.5 PK			1.00 H	257	79.16	31.34
2	*2437.00	107.2 AV			1.00 H	257	75.86	31.34
3	4874.00	61.5 PK	74.0	-12.5	1.15 H	88	21.88	39.62
4	4874.00	51.3 AV	54.0	-2.7	1.15 H	88	11.68	39.62
5	7311.00	52.9 PK	74.0	-21.1	1.00 H	46	8.80	44.10
6	7311.00	42.6 AV	54.0	-11.4	1.00 H	46	-1.50	44.10
ANTENNA POLARITY & TEST DISTANCE: VERTICAL AT 3 M								
NO.	FREQ. (MHz)	EMISSION LEVEL (dBuV/m)	LIMIT (dBuV/m)	MARGIN (dB)	ANTENNA HEIGHT (m)	TABLE ANGLE (Degree)	RAW VALUE (dBuV)	CORRECTION FACTOR (dB/m)
1	*2437.00	95.7 PK			1.68 V	7	64.36	31.34
2	*2437.00	93.3 AV			1.68 V	7	61.96	31.34
3	4874.00	55.9 PK	74.0	-18.1	1.00 V	188	16.28	39.62
4	4874.00	52.8 AV	54.0	-1.2	1.00 V	188	13.18	39.62
5	7311.00	54.9 PK	74.0	-19.1	1.25 V	66	10.80	44.10
6	7311.00	45.7 AV	54.0	-8.3	1.25 V	66	1.60	44.10

- REMARKS:**
1. Emission level (dBuV/m) = Raw Value (dBuV) + Correction Factor (dB/m).
  2. Correction Factor (dB/m) = Antenna Factor (dB/m) + Cable Factor (dB).
  3. The other emission levels were very low against the limit.
  4. Margin value = Emission level – Limit value.
  5. “ \* “: Fundamental frequency.



A D T

EUT TEST CONDITION		MEASUREMENT DETAIL	
CHANNEL	Channel 11	FREQUENCY RANGE	1 ~ 25GHz
INPUT POWER	120V / 60Hz	DETECTOR FUNCTION	Peak (PK) Average (AV)
ENVIRONMENTAL CONDITIONS	25deg. C, 65%RH 1003 hPa	TESTED BY	Frank Liu

**ANTENNA POLARITY & TEST DISTANCE: HORIZONTAL AT 3 M**

NO.	FREQ. (MHz)	EMISSION LEVEL (dBuV/m)	LIMIT (dBuV/m)	MARGIN (dB)	ANTENNA HEIGHT (m)	TABLE ANGLE (Degree)	RAW VALUE (dBuV)	CORRECTION FACTOR (dB/m)
1	*2462.00	109.2 PK			1.00 H	251	77.80	31.40
2	*2462.00	106.4 AV			1.00 H	251	75.00	31.40
3	2483.50	58.4 PK	74.0	-15.6	1.00 H	251	26.94	31.46
4	2483.50	46.5 AV	54.0	-7.5	1.00 H	251	15.04	31.46
5	4924.00	60.8 PK	74.0	-13.2	1.17 H	89	20.98	39.82
6	4924.00	51.1 AV	54.0	-2.9	1.17 H	89	11.28	39.82
7	7386.00	51.8 PK	74.0	-22.2	1.00 H	38	7.62	44.18
8	7386.00	41.7 AV	54.0	-12.3	1.00 H	38	-2.48	44.18

**ANTENNA POLARITY & TEST DISTANCE: VERTICAL AT 3 M**

NO.	FREQ. (MHz)	EMISSION LEVEL (dBuV/m)	LIMIT (dBuV/m)	MARGIN (dB)	ANTENNA HEIGHT (m)	TABLE ANGLE (Degree)	RAW VALUE (dBuV)	CORRECTION FACTOR (dB/m)
1	*2462.00	94.7 PK			1.67 V	8	63.30	31.40
2	*2462.00	92.3 AV			1.67 V	8	60.90	31.40
3	2483.50	57.0 PK	74.0	-17.0	1.67 V	9	25.54	31.46
4	2483.50	43.3 AV	54.0	-10.7	1.67 V	9	11.84	31.46
5	4924.00	52.7 PK	74.0	-21.3	1.00 V	261	12.88	39.82
6	4924.00	49.0 AV	54.0	-5.0	1.00 V	261	9.18	39.82
7	7386.00	53.9 PK	74.0	-20.1	1.27 V	63	9.72	44.18
8	7386.00	44.5 AV	54.0	-9.5	1.27 V	63	0.32	44.18

- REMARKS:**
1. Emission level (dBuV/m) = Raw Value (dBuV) + Correction Factor (dB/m).
  2. Correction Factor (dB/m) = Antenna Factor (dB/m) + Cable Factor (dB).
  3. The other emission levels were very low against the limit.
  4. Margin value = Emission level – Limit value.
  5. “ \* “: Fundamental frequency.



A D T

RESTRICTED BANDEDGE (802.11b MODE, CH1, HORIZONTAL)

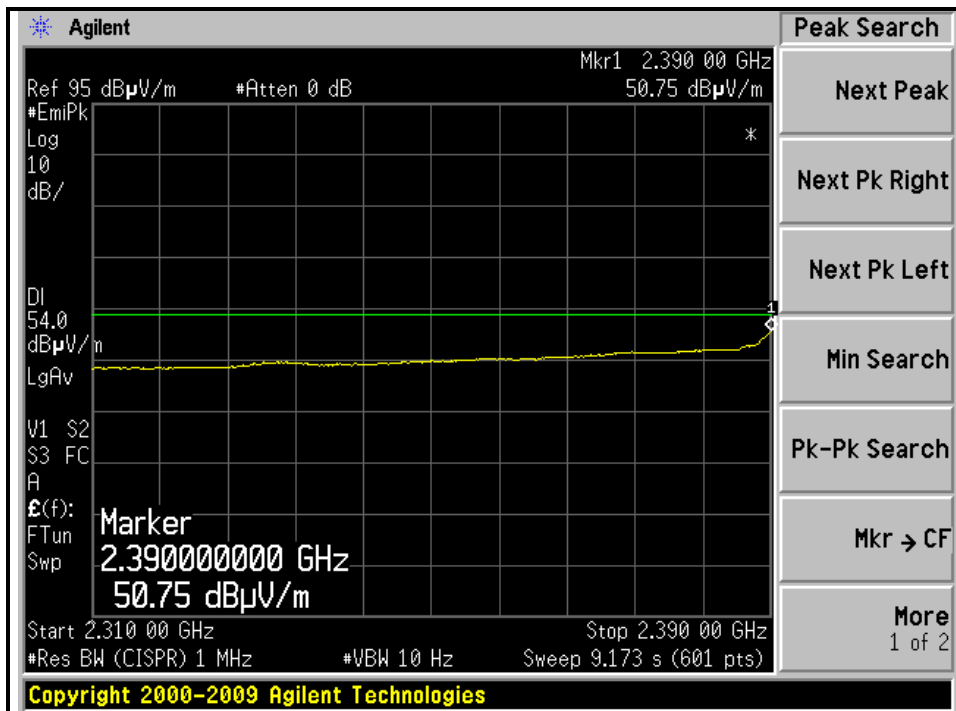
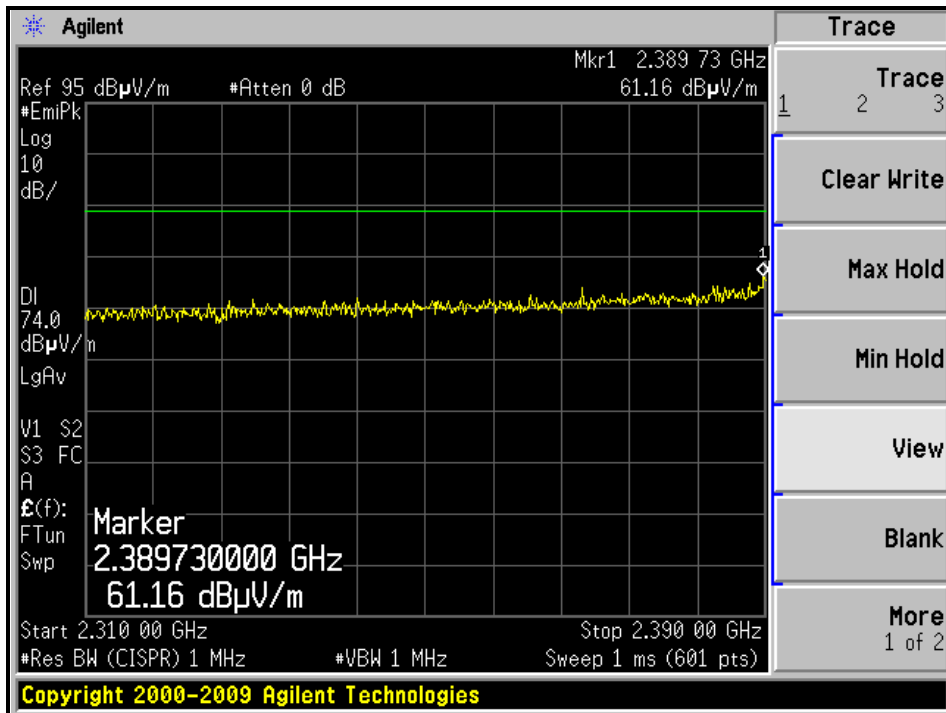





A D T

### RESTRICTED BANDEDGE (802.11b MODE, CH1, VERTICAL )

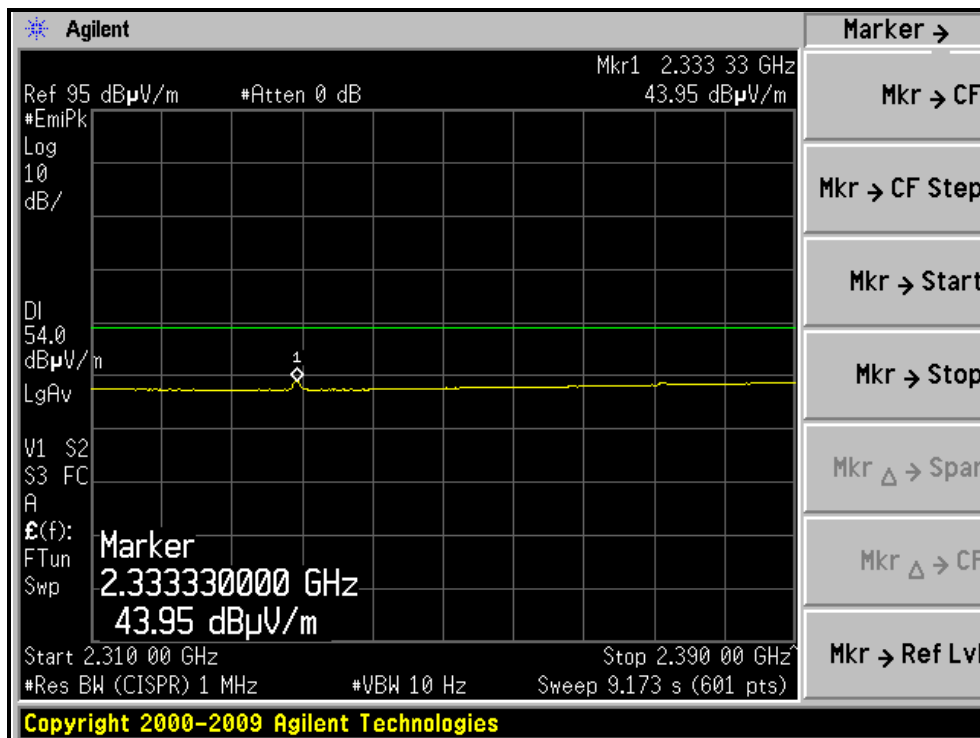
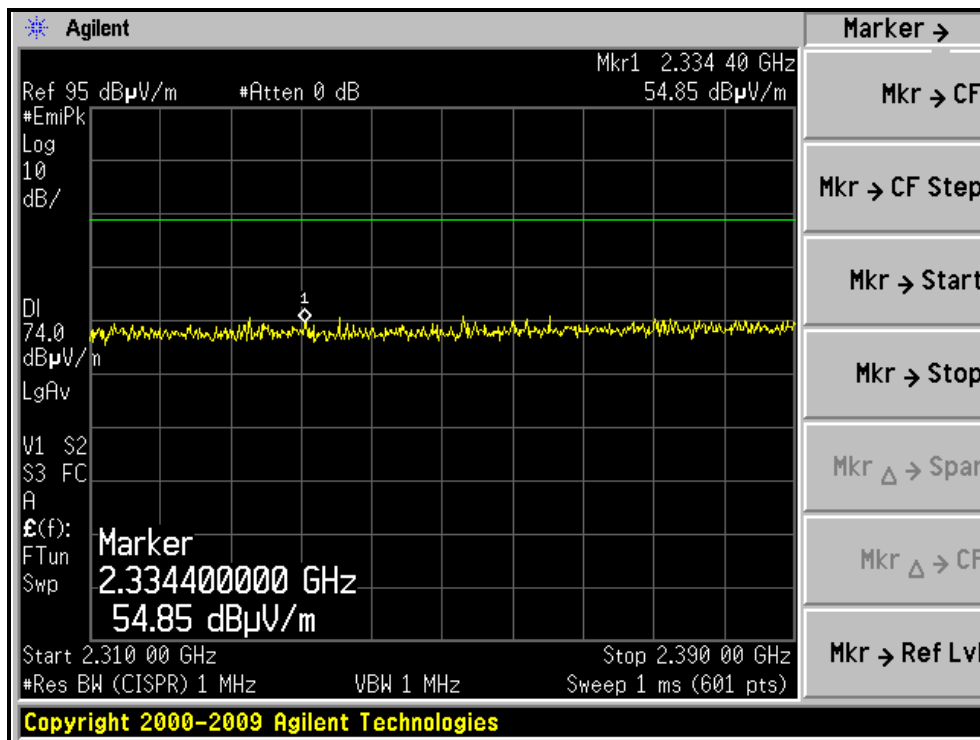



A D T

### RESTRICTED BANDEDGE (802.11b MODE, CH11, HORIZONTAL )

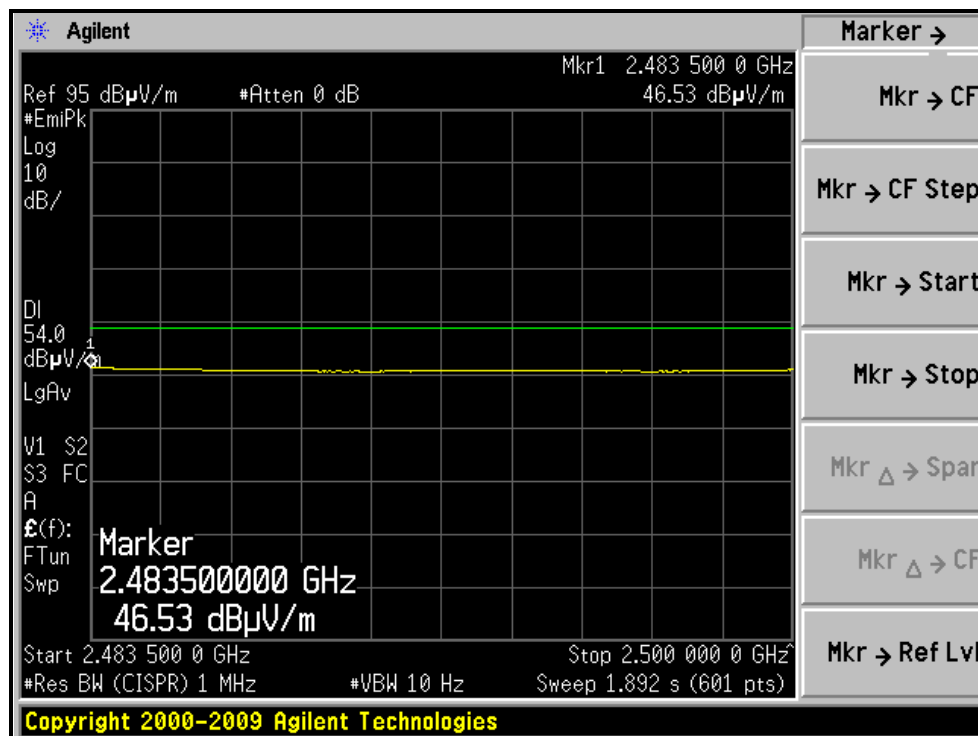
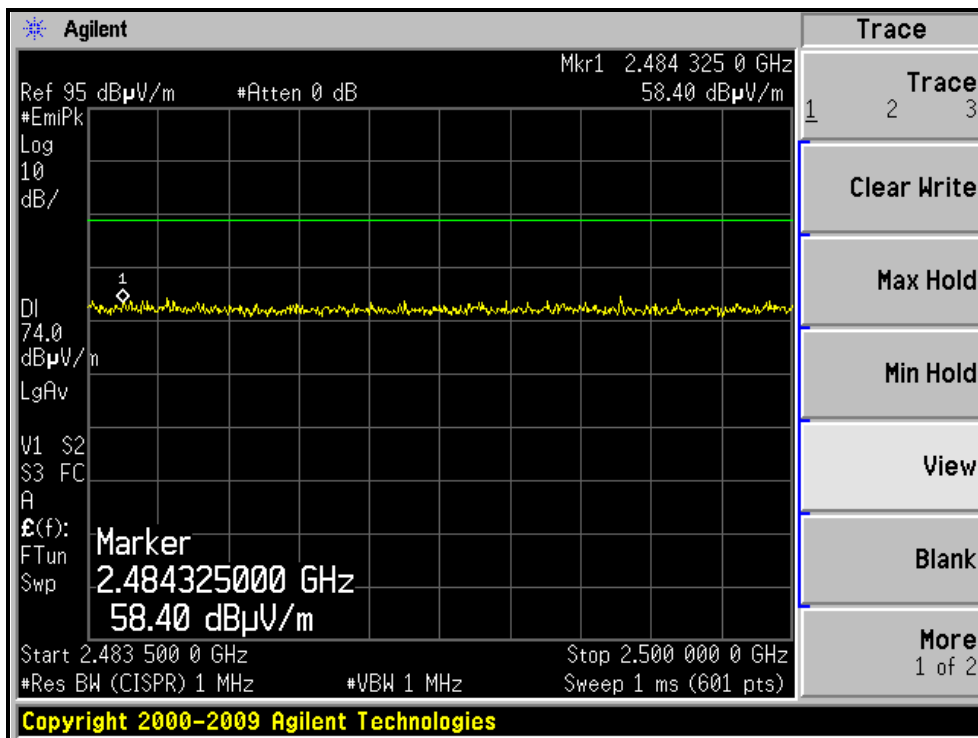



A D T

### RESTRICTED BANDEDGE (802.11b MODE, CH11, VERTICAL)

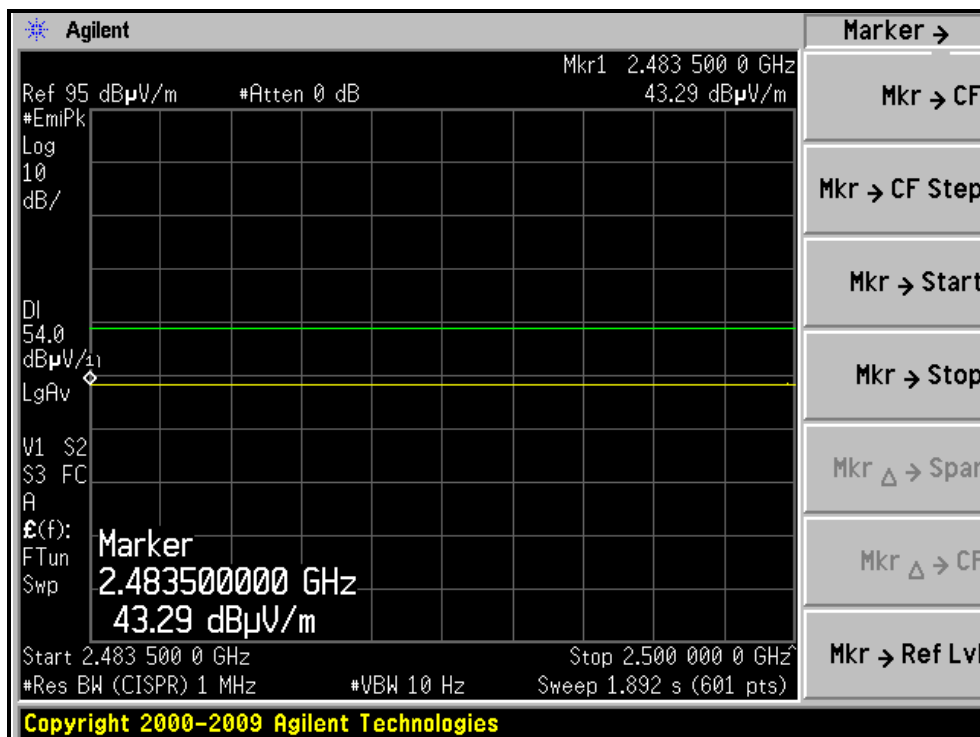
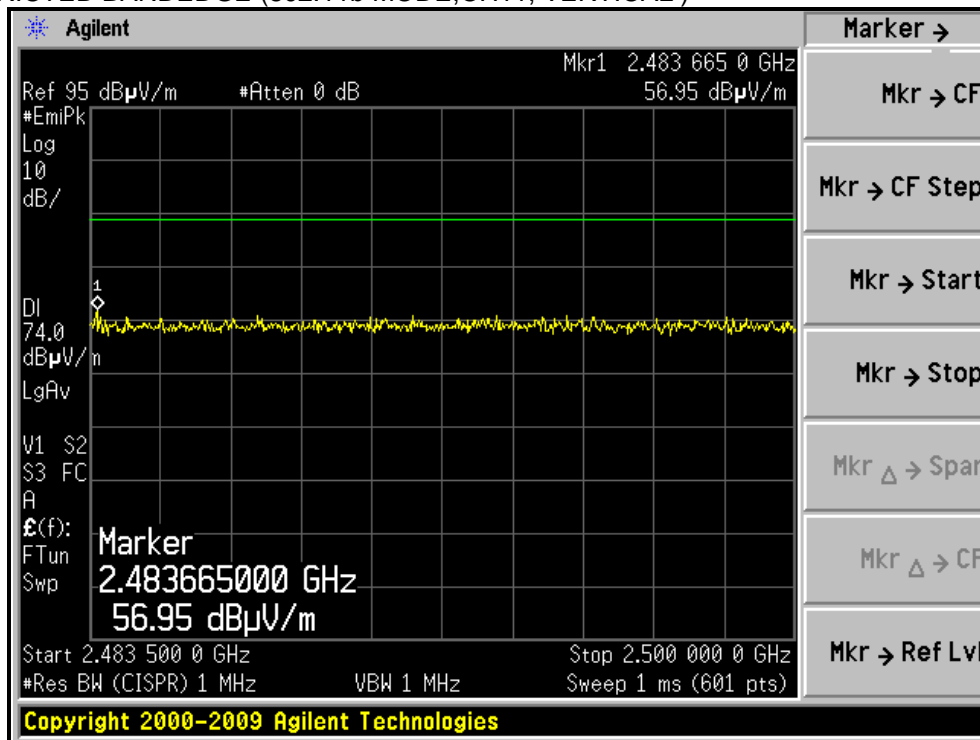



A D T

**802.11g OFDM MODULATION**

EUT TEST CONDITION		MEASUREMENT DETAIL	
CHANNEL	Channel 1	FREQUENCY RANGE	1 ~ 25GHz
INPUT POWER	120V / 60Hz	DETECTOR FUNCTION	Peak (PK) Average (AV)
ENVIRONMENTAL CONDITIONS	25deg. C, 65%RH 1003 hPa	TESTED BY	Frank Liu

ANTENNA POLARITY & TEST DISTANCE: HORIZONTAL AT 3 M								
NO.	FREQ. (MHz)	EMISSION LEVEL (dBuV/m)	LIMIT (dBuV/m)	MARGIN (dB)	ANTENNA HEIGHT (m)	TABLE ANGLE (Degree)	RAW VALUE (dBuV)	CORRECTION FACTOR (dB/m)
1	2390.00	65.3 PK	74.0	-8.7	1.00 H	253	34.09	31.21
2	2390.00	52.8 AV	54.0	-1.2	1.00 H	253	21.59	31.21
3	*2412.00	109.7 PK			1.00 H	252	78.43	31.27
4	*2412.00	100.6 AV			1.00 H	252	69.33	31.27
5	4824.00	51.5 PK	74.0	-22.5	1.17 H	86	12.08	39.42
6	4824.00	37.6 AV	54.0	-16.4	1.17 H	86	-1.82	39.42
ANTENNA POLARITY & TEST DISTANCE: VERTICAL AT 3 M								
NO.	FREQ. (MHz)	EMISSION LEVEL (dBuV/m)	LIMIT (dBuV/m)	MARGIN (dB)	ANTENNA HEIGHT (m)	TABLE ANGLE (Degree)	RAW VALUE (dBuV)	CORRECTION FACTOR (dB/m)
1	2390.00	59.4 PK	74.0	-14.6	1.76 V	4	28.19	31.21
2	2390.00	45.6 AV	54.0	-8.4	1.76 V	4	14.39	31.21
3	*2412.00	96.5 PK			1.76 V	5	65.23	31.27
4	*2412.00	86.7 AV			1.76 V	5	55.43	31.27
5	4824.00	52.7 PK	74.0	-21.3	1.22 V	108	13.28	39.42
6	4824.00	38.2 AV	54.0	-15.8	1.22 V	108	-1.22	39.42

- REMARKS:**
1. Emission level (dBuV/m) = Raw Value (dBuV) + Correction Factor (dB/m).
  2. Correction Factor (dB/m) = Antenna Factor (dB/m) + Cable Factor (dB).
  3. The other emission levels were very low against the limit.
  4. Margin value = Emission level – Limit value.
  5. “ \* “: Fundamental frequency.



A D T

EUT TEST CONDITION		MEASUREMENT DETAIL	
CHANNEL	Channel 6	FREQUENCY RANGE	1 ~ 25GHz
INPUT POWER	120V / 60Hz	DETECTOR FUNCTION	Peak (PK) Average (AV)
ENVIRONMENTAL CONDITIONS	25deg. C, 65%RH 1003 hPa	TESTED BY	Frank Liu

**ANTENNA POLARITY & TEST DISTANCE: HORIZONTAL AT 3 M**

NO.	FREQ. (MHz)	EMISSION LEVEL (dBuV/m)	LIMIT (dBuV/m)	MARGIN (dB)	ANTENNA HEIGHT (m)	TABLE ANGLE (Degree)	RAW VALUE (dBuV)	CORRECTION FACTOR (dB/m)
1	2390.00	61.7 PK	74.0	-12.3	1.00 H	251	30.49	31.21
2	2390.00	52.0 AV	54.0	-2.0	1.00 H	251	20.79	31.21
3	*2437.00	114.4 PK			1.00 H	249	83.06	31.34
4	*2437.00	105.0 AV			1.00 H	249	73.66	31.34
5	2483.50	66.0 PK	74.0	-8.0	1.00 H	254	34.54	31.46
6	<b>2483.50</b>	<b>53.0 AV</b>	<b>54.0</b>	<b>-1.0</b>	<b>1.00 H</b>	<b>254</b>	<b>21.54</b>	<b>31.46</b>
7	4874.00	52.7 PK	74.0	-21.3	1.15 H	87	13.08	39.62
8	4874.00	39.8 AV	54.0	-14.2	1.15 H	87	0.18	39.62
9	7311.00	53.8 PK	74.0	-20.2	1.00 H	37	9.70	44.10
10	7311.00	42.4 AV	54.0	-11.6	1.00 H	37	-1.70	44.10

**ANTENNA POLARITY & TEST DISTANCE: VERTICAL AT 3 M**

NO.	FREQ. (MHz)	EMISSION LEVEL (dBuV/m)	LIMIT (dBuV/m)	MARGIN (dB)	ANTENNA HEIGHT (m)	TABLE ANGLE (Degree)	RAW VALUE (dBuV)	CORRECTION FACTOR (dB/m)
1	*2437.00	100.9 PK			1.75 V	8	69.56	31.34
2	*2437.00	91.0 AV			1.75 V	8	59.66	31.34
3	4874.00	53.9 PK	74.0	-20.1	1.00 V	188	14.28	39.62
4	4874.00	40.8 AV	54.0	-13.2	1.00 V	188	1.18	39.62
5	7311.00	56.7 PK	74.0	-17.3	1.29 V	111	12.60	44.10
6	7311.00	44.4 AV	54.0	-9.6	1.29 V	111	0.30	44.10

- REMARKS:**
1. Emission level (dBuV/m) = Raw Value (dBuV) + Correction Factor (dB/m).
  2. Correction Factor (dB/m) = Antenna Factor (dB/m) + Cable Factor (dB).
  3. The other emission levels were very low against the limit.
  4. Margin value = Emission level – Limit value.
  5. “ \* “: Fundamental frequency.



A D T

EUT TEST CONDITION		MEASUREMENT DETAIL	
CHANNEL	Channel 11	FREQUENCY RANGE	1 ~ 25GHz
INPUT POWER	120V / 60Hz	DETECTOR FUNCTION	Peak (PK) Average (AV)
ENVIRONMENTAL CONDITIONS	25deg. C, 65%RH 1003 hPa	TESTED BY	Frank Liu

**ANTENNA POLARITY & TEST DISTANCE: HORIZONTAL AT 3 M**

NO.	FREQ. (MHz)	EMISSION LEVEL (dBuV/m)	LIMIT (dBuV/m)	MARGIN (dB)	ANTENNA HEIGHT (m)	TABLE ANGLE (Degree)	RAW VALUE (dBuV)	CORRECTION FACTOR (dB/m)
1	*2462.00	108.3 PK			1.00 H	252	76.90	31.40
2	*2462.00	98.3 AV			1.00 H	252	66.90	31.40
3	2493.26	64.1 PK	74.0	-9.9	1.00 H	255	32.62	31.48
4	2493.26	52.5 AV	54.0	-1.5	1.00 H	255	21.02	31.48
5	4924.00	51.0 PK	74.0	-23.0	1.15 H	88	11.18	39.82
6	4924.00	37.3 AV	54.0	-16.7	1.15 H	88	-2.52	39.82
7	7386.00	52.2 PK	74.0	-21.8	1.00 H	39	8.02	44.18
8	7386.00	41.3 AV	54.0	-12.7	1.00 H	39	-2.88	44.18

**ANTENNA POLARITY & TEST DISTANCE: VERTICAL AT 3 M**

NO.	FREQ. (MHz)	EMISSION LEVEL (dBuV/m)	LIMIT (dBuV/m)	MARGIN (dB)	ANTENNA HEIGHT (m)	TABLE ANGLE (Degree)	RAW VALUE (dBuV)	CORRECTION FACTOR (dB/m)
1	*2462.00	95.3 PK			1.67 V	6	63.90	31.40
2	*2462.00	85.1 AV			1.67 V	6	53.70	31.40
3	2483.50	56.7 PK	74.0	-17.3	1.67 V	6	25.24	31.46
4	2483.50	44.5 AV	54.0	-9.5	1.67 V	6	13.04	31.46
5	4924.00	52.6 PK	74.0	-21.4	1.18 V	100	12.78	39.82
6	4924.00	38.2 AV	54.0	-15.8	1.18 V	100	-1.62	39.82
7	7386.00	54.1 PK	74.0	-19.9	1.22 V	117	9.92	44.18
8	7386.00	42.3 AV	54.0	-11.7	1.22 V	117	-1.88	44.18

- REMARKS:**
1. Emission level (dBuV/m) = Raw Value (dBuV) + Correction Factor (dB/m).
  2. Correction Factor (dB/m) = Antenna Factor (dB/m) + Cable Factor (dB).
  3. The other emission levels were very low against the limit.
  4. Margin value = Emission level – Limit value.
  5. “ \* “: Fundamental frequency.



A D T

RESTRICTED BANDEDGE (802.11g MODE, CH1, HORIZONTAL )

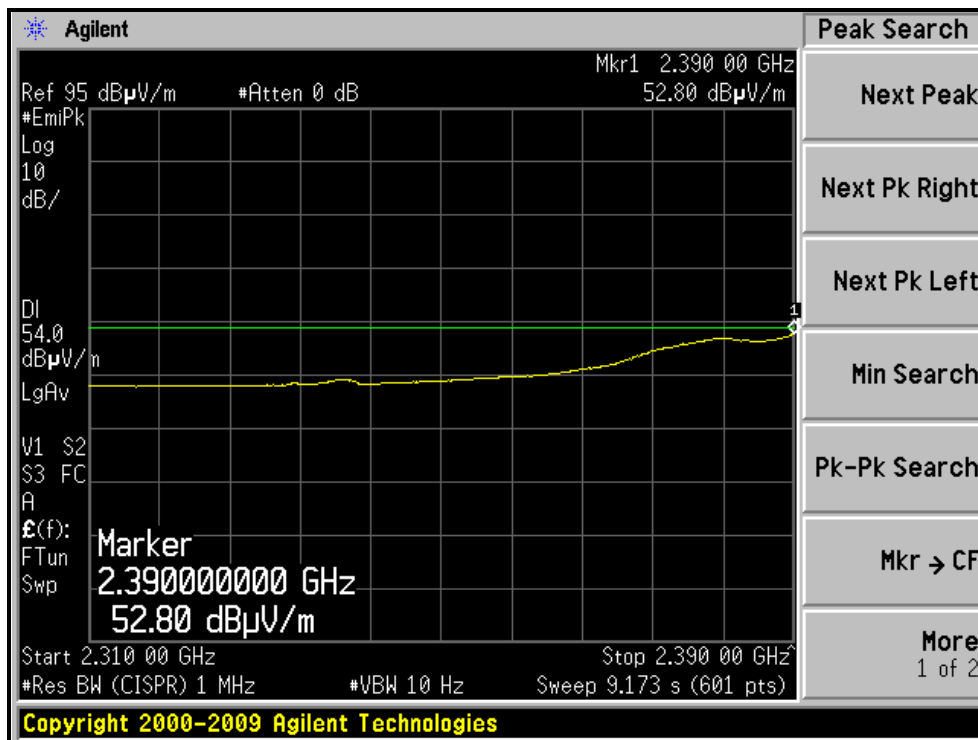
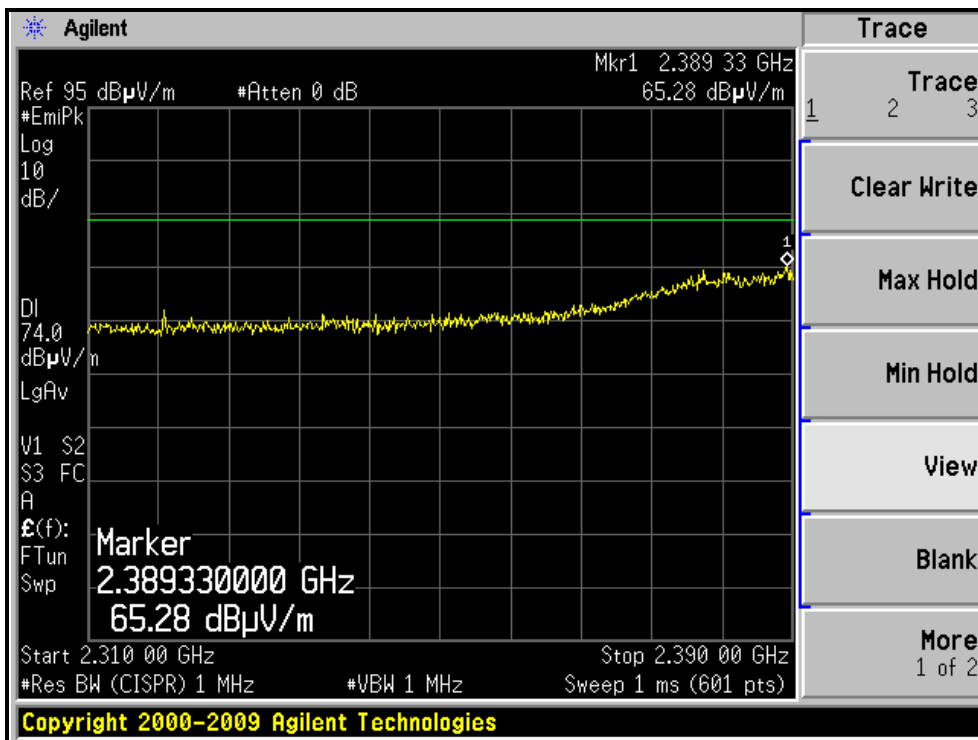

RESTRICTED BANDEDGE (802.11g MODE, CH1, VERTICAL )

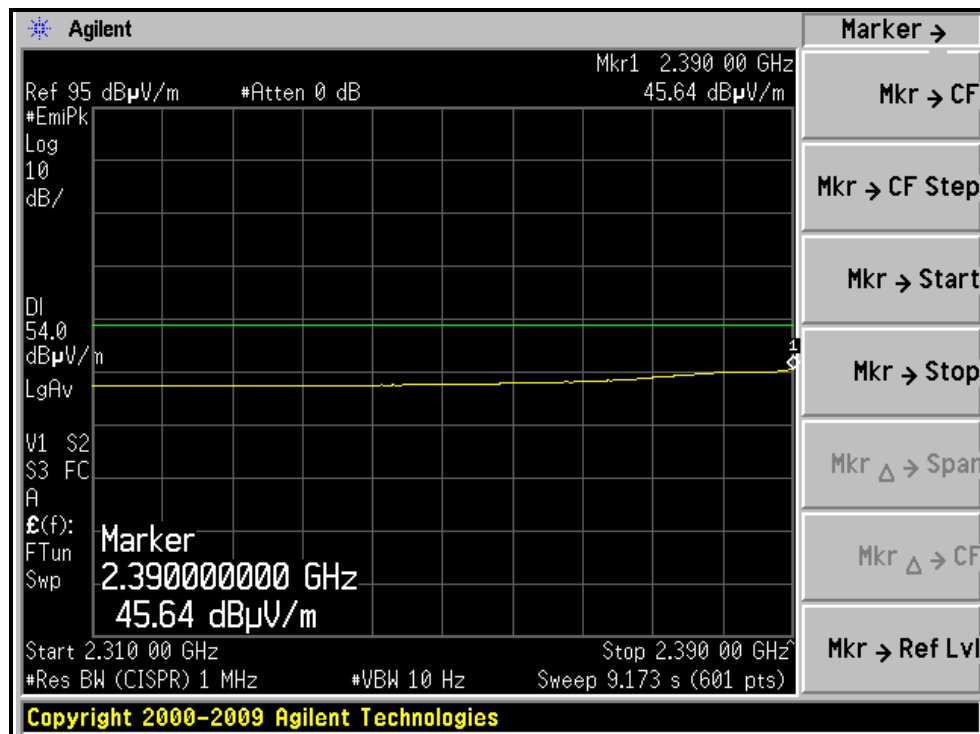
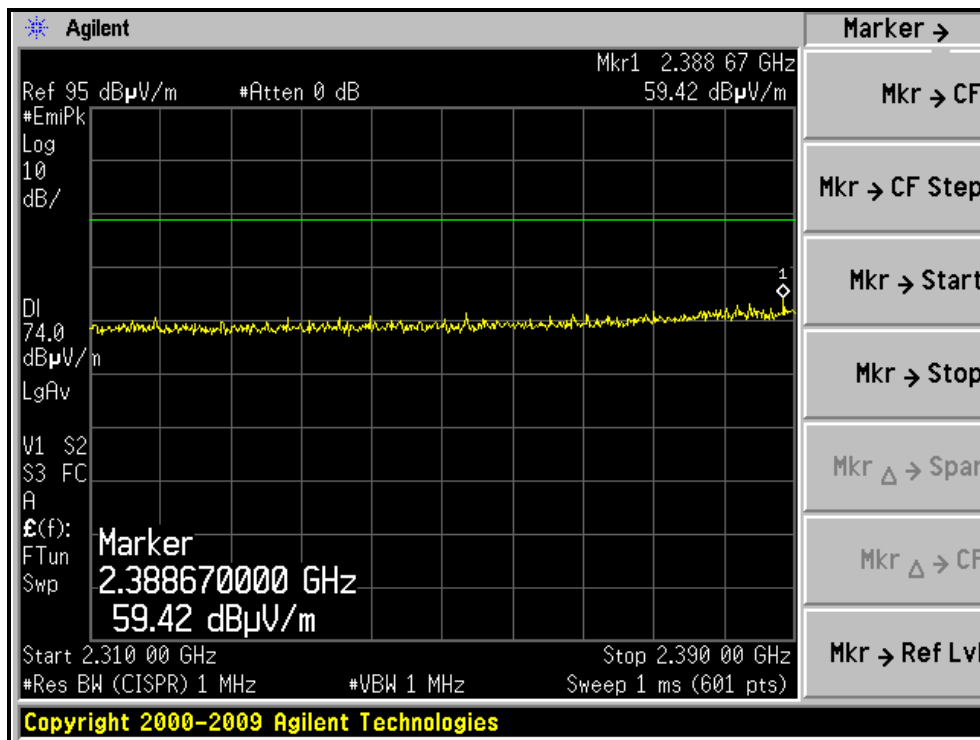





A D T

RESTRICTED BANDEDGE (802.11g MODE, CH11, HORIZONTAL )

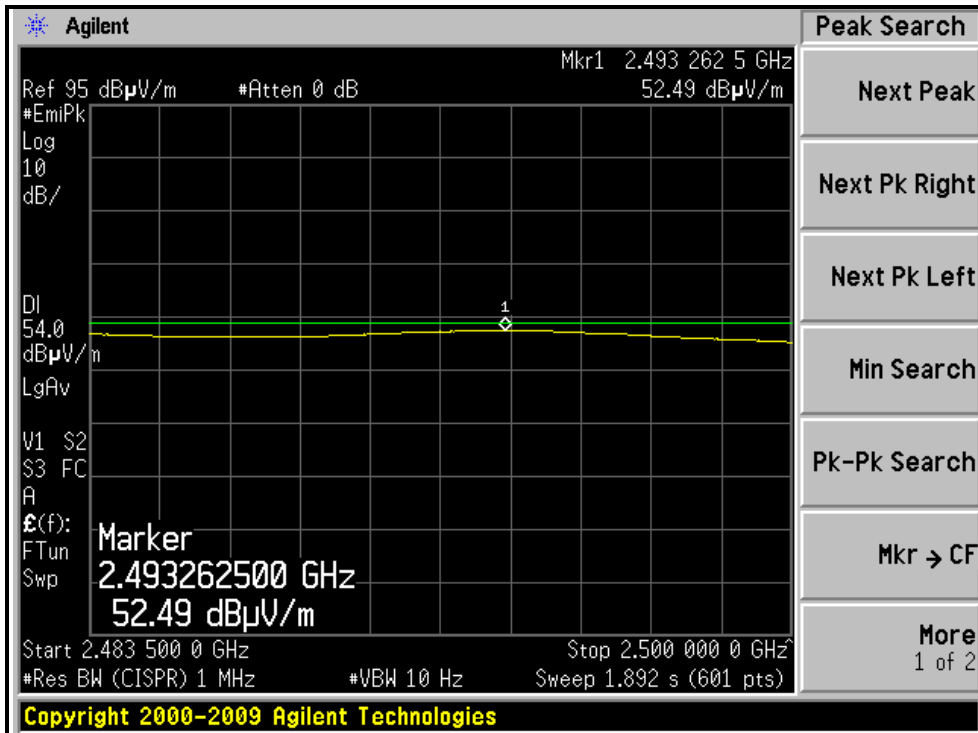
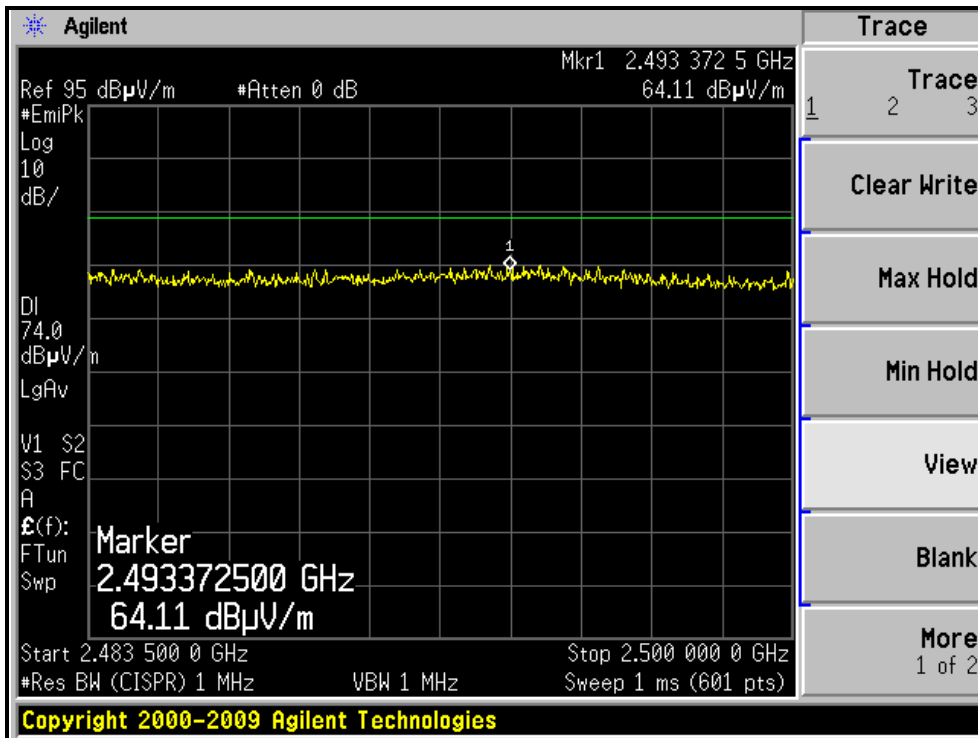

RESTRICTED BANDEDGE (802.11g MODE, CH11, VERTICAL )

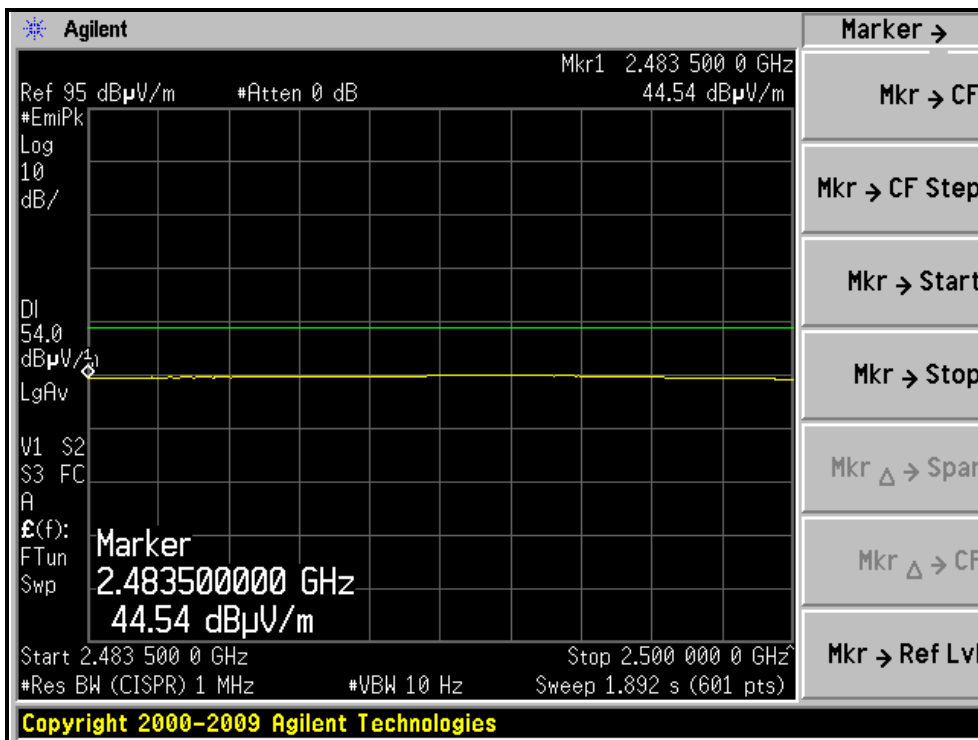
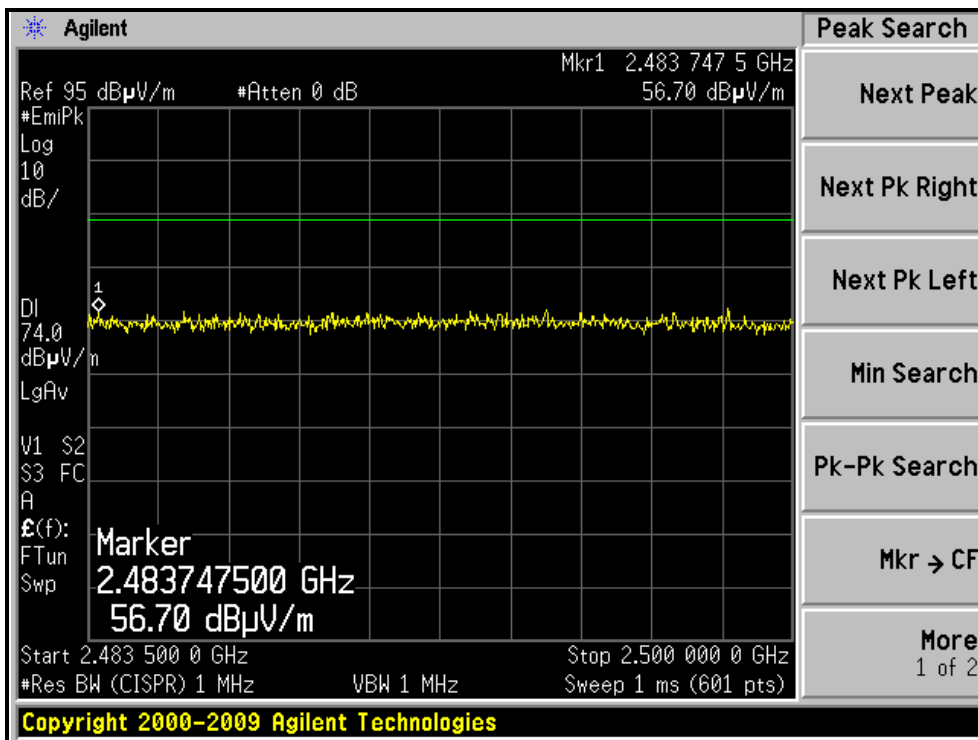



A D T

**802.11n (20MHz) OFDM MODULATION**

EUT TEST CONDITION		MEASUREMENT DETAIL	
CHANNEL	Channel 1	FREQUENCY RANGE	1 ~ 25GHz
INPUT POWER	120V / 60Hz	DETECTOR FUNCTION	Peak (PK) Average (AV)
ENVIRONMENTAL CONDITIONS	25deg. C, 65%RH 1003 hPa	TESTED BY	Frank Liu

ANTENNA POLARITY & TEST DISTANCE: HORIZONTAL AT 3 M								
NO.	FREQ. (MHz)	EMISSION LEVEL (dBuV/m)	LIMIT (dBuV/m)	MARGIN (dB)	ANTENNA HEIGHT (m)	TABLE ANGLE (Degree)	RAW VALUE (dBuV)	CORRECTION FACTOR (dB/m)
1	2390.00	63.8 PK	74.0	-10.2	1.00 H	252	32.59	31.21
2	2390.00	52.9 AV	54.0	-1.1	1.00 H	252	21.69	31.21
3	*2412.00	108.4 PK			1.00 H	252	77.13	31.27
4	*2412.00	98.6 AV			1.00 H	252	67.33	31.27
5	4824.00	51.4 PK	74.0	-22.6	1.18 H	98	11.98	39.42
6	4824.00	37.7 AV	54.0	-16.3	1.18 H	98	-1.72	39.42
ANTENNA POLARITY & TEST DISTANCE: VERTICAL AT 3 M								
NO.	FREQ. (MHz)	EMISSION LEVEL (dBuV/m)	LIMIT (dBuV/m)	MARGIN (dB)	ANTENNA HEIGHT (m)	TABLE ANGLE (Degree)	RAW VALUE (dBuV)	CORRECTION FACTOR (dB/m)
1	2390.00	58.1 PK	74.0	-15.9	1.76 V	7	26.89	31.21
2	2390.00	45.6 AV	54.0	-8.4	1.76 V	7	14.39	31.21
3	*2412.00	95.2 PK			1.77 V	5	63.93	31.27
4	*2412.00	85.2 AV			1.77 V	5	53.93	31.27
5	4824.00	52.9 PK	74.0	-21.1	1.24 V	106	13.48	39.42
6	4824.00	38.5 AV	54.0	-15.5	1.24 V	106	-0.92	39.42

- REMARKS:**
1. Emission level (dBuV/m) = Raw Value (dBuV) + Correction Factor (dB/m).
  2. Correction Factor (dB/m) = Antenna Factor (dB/m) + Cable Factor (dB).
  3. The other emission levels were very low against the limit.
  4. Margin value = Emission level – Limit value.
  5. “ \* “: Fundamental frequency.



A D T

EUT TEST CONDITION		MEASUREMENT DETAIL	
CHANNEL	Channel 6	FREQUENCY RANGE	1 ~ 25GHz
INPUT POWER	120V / 60Hz	DETECTOR FUNCTION	Peak (PK) Average (AV)
ENVIRONMENTAL CONDITIONS	25deg. C, 65%RH 1003 hPa	TESTED BY	Frank Liu

ANTENNA POLARITY & TEST DISTANCE: HORIZONTAL AT 3 M								
NO.	FREQ. (MHz)	EMISSION LEVEL (dBuV/m)	LIMIT (dBuV/m)	MARGIN (dB)	ANTENNA HEIGHT (m)	TABLE ANGLE (Degree)	RAW VALUE (dBuV)	CORRECTION FACTOR (dB/m)
1	2390.00	61.8 PK	74.0	-12.2	1.00 H	254	30.59	31.21
2	2390.00	52.3 AV	54.0	-1.7	1.00 H	254	21.09	31.21
3	*2437.00	113.5 PK			1.02 H	251	82.16	31.34
4	*2437.00	103.9 AV			1.02 H	251	72.56	31.34
5	2483.50	66.4 PK	74.0	-7.6	1.00 H	254	34.94	31.46
6	<b>2483.50</b>	<b>53.0 AV</b>	<b>54.0</b>	<b>-1.0</b>	<b>1.00 H</b>	<b>254</b>	<b>21.54</b>	<b>31.46</b>
7	4874.00	52.5 PK	74.0	-21.5	1.10 H	99	12.88	39.62
8	4874.00	39.9 AV	54.0	-14.1	1.10 H	99	0.28	39.62
9	7311.00	53.8 PK	74.0	-20.2	1.00 H	33	9.70	44.10
10	7311.00	42.6 AV	54.0	-11.4	1.00 H	33	-1.50	44.10
ANTENNA POLARITY & TEST DISTANCE: VERTICAL AT 3 M								
NO.	FREQ. (MHz)	EMISSION LEVEL (dBuV/m)	LIMIT (dBuV/m)	MARGIN (dB)	ANTENNA HEIGHT (m)	TABLE ANGLE (Degree)	RAW VALUE (dBuV)	CORRECTION FACTOR (dB/m)
1	*2437.00	100.0 PK			1.78 V	10	68.66	31.34
2	*2437.00	90.1 AV			1.78 V	10	58.76	31.34
3	4874.00	53.8 PK	74.0	-20.2	1.00 V	189	14.18	39.62
4	4874.00	40.6 AV	54.0	-13.4	1.00 V	189	0.98	39.62
5	7311.00	56.8 PK	74.0	-17.2	1.29 V	98	12.70	44.10
6	7311.00	44.5 AV	54.0	-9.5	1.29 V	98	0.40	44.10

- REMARKS:**
1. Emission level (dBuV/m) = Raw Value (dBuV) + Correction Factor (dB/m).
  2. Correction Factor (dB/m) = Antenna Factor (dB/m) + Cable Factor (dB).
  3. The other emission levels were very low against the limit.
  4. Margin value = Emission level – Limit value.
  5. “ \* “: Fundamental frequency.



A D T

EUT TEST CONDITION		MEASUREMENT DETAIL	
CHANNEL	Channel 11	FREQUENCY RANGE	1 ~ 25GHz
INPUT POWER	120V / 60Hz	DETECTOR FUNCTION	Peak (PK) Average (AV)
ENVIRONMENTAL CONDITIONS	25deg. C, 65%RH 1003 hPa	TESTED BY	Frank Liu

**ANTENNA POLARITY & TEST DISTANCE: HORIZONTAL AT 3 M**

NO.	FREQ. (MHz)	EMISSION LEVEL (dBuV/m)	LIMIT (dBuV/m)	MARGIN (dB)	ANTENNA HEIGHT (m)	TABLE ANGLE (Degree)	RAW VALUE (dBuV)	CORRECTION FACTOR (dB/m)
1	*2462.00	107.8 PK			1.02 H	262	76.40	31.40
2	*2462.00	97.9 AV			1.02 H	262	66.50	31.40
3	2492.68	65.8 PK	74.0	-8.2	1.00 H	253	34.32	31.48
4	2492.68	52.8 AV	54.0	-1.2	1.00 H	253	21.32	31.48
5	4924.00	50.9 PK	74.0	-23.1	1.11 H	84	11.08	39.82
6	4924.00	37.4 AV	54.0	-16.6	1.11 H	84	-2.42	39.82
7	7386.00	52.7 PK	74.0	-21.3	1.05 H	40	8.52	44.18
8	7386.00	41.6 AV	54.0	-12.4	1.05 H	40	-2.58	44.18

**ANTENNA POLARITY & TEST DISTANCE: VERTICAL AT 3 M**

NO.	FREQ. (MHz)	EMISSION LEVEL (dBuV/m)	LIMIT (dBuV/m)	MARGIN (dB)	ANTENNA HEIGHT (m)	TABLE ANGLE (Degree)	RAW VALUE (dBuV)	CORRECTION FACTOR (dB/m)
1	*2462.00	94.6 PK			1.67 V	20	63.20	31.40
2	*2462.00	84.4 AV			1.67 V	20	53.00	31.40
3	2483.50	57.3 PK	74.0	-16.7	1.66 V	8	25.84	31.46
4	2483.50	44.3 AV	54.0	-9.7	1.66 V	8	12.84	31.46
5	4924.00	52.5 PK	74.0	-21.5	1.18 V	110	12.68	39.82
6	4924.00	38.1 AV	54.0	-15.9	1.18 V	110	-1.72	39.82
7	7386.00	54.2 PK	74.0	-19.8	1.25 V	126	10.02	44.18
8	7386.00	42.2 AV	54.0	-11.8	1.25 V	126	-1.98	44.18

- REMARKS:**
1. Emission level (dBuV/m) = Raw Value (dBuV) + Correction Factor (dB/m).
  2. Correction Factor (dB/m) = Antenna Factor (dB/m) + Cable Factor (dB).
  3. The other emission levels were very low against the limit.
  4. Margin value = Emission level – Limit value.
  5. “ \* “: Fundamental frequency.



A D T

RESTRICTED BANDEDGE (802.11n (20MHz) MODE,CH1, HORIZONTAL )

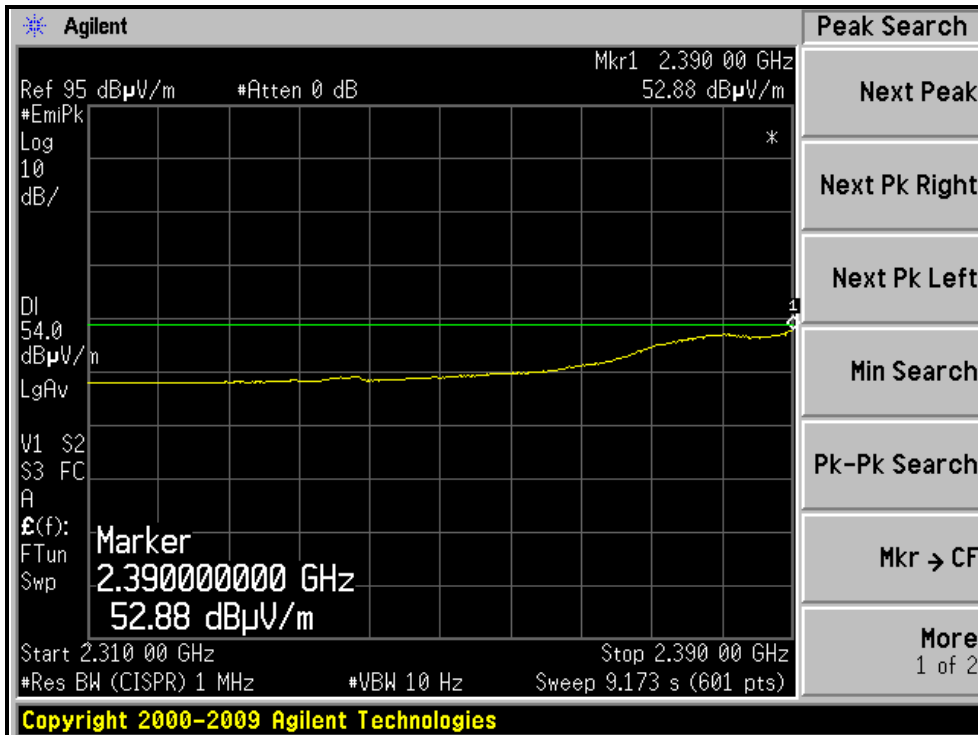
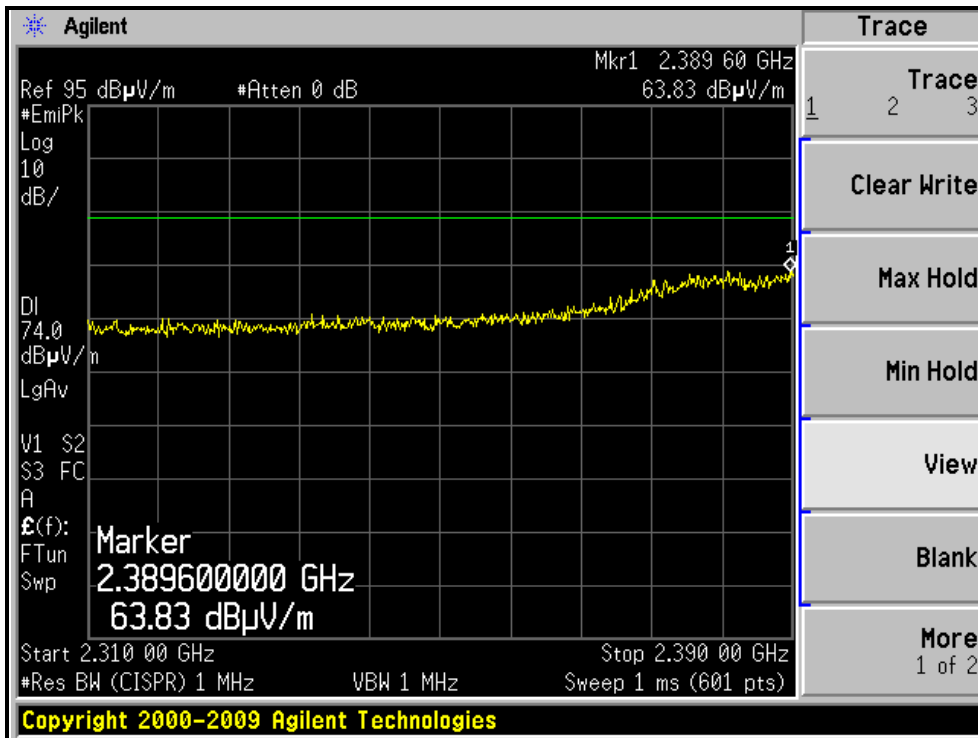



A D T

RESTRICTED BANDEDGE (802.11n (20MHz) MODE,CH1, VERTICAL )

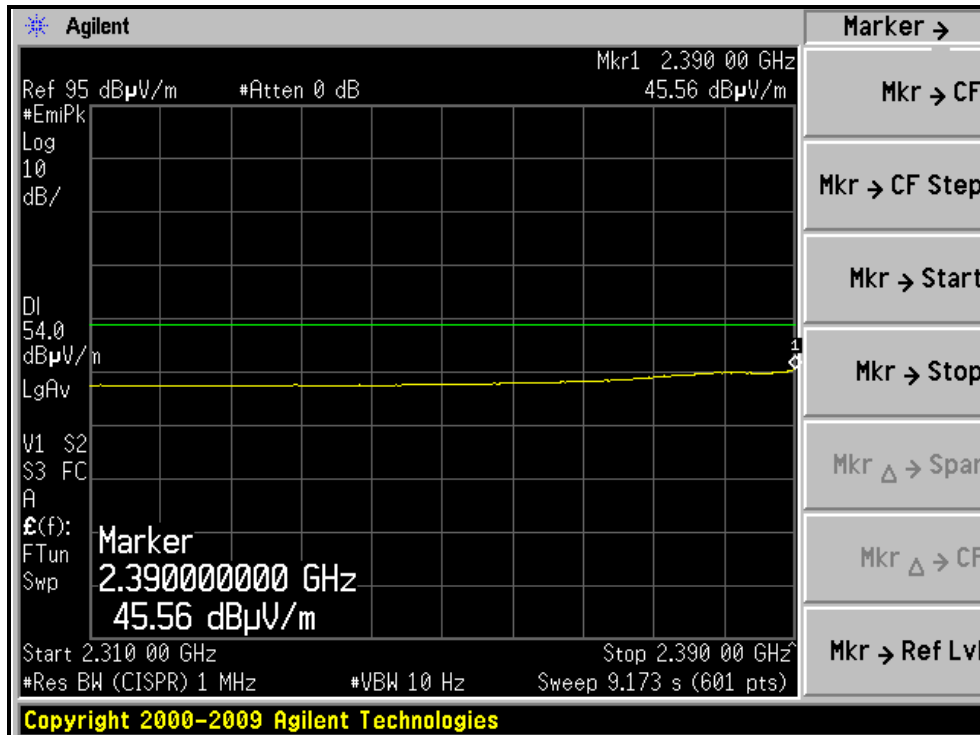
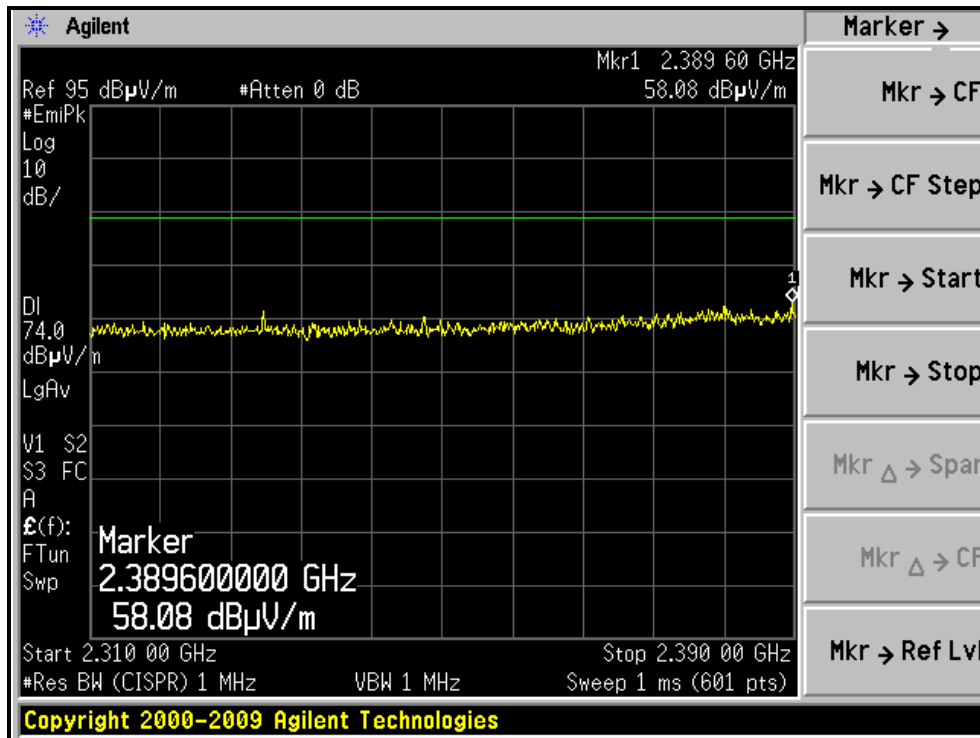



A D T

RESTRICTED BANDEDGE (802.11n (20MHz) MODE,CH11, HORIZONTAL )

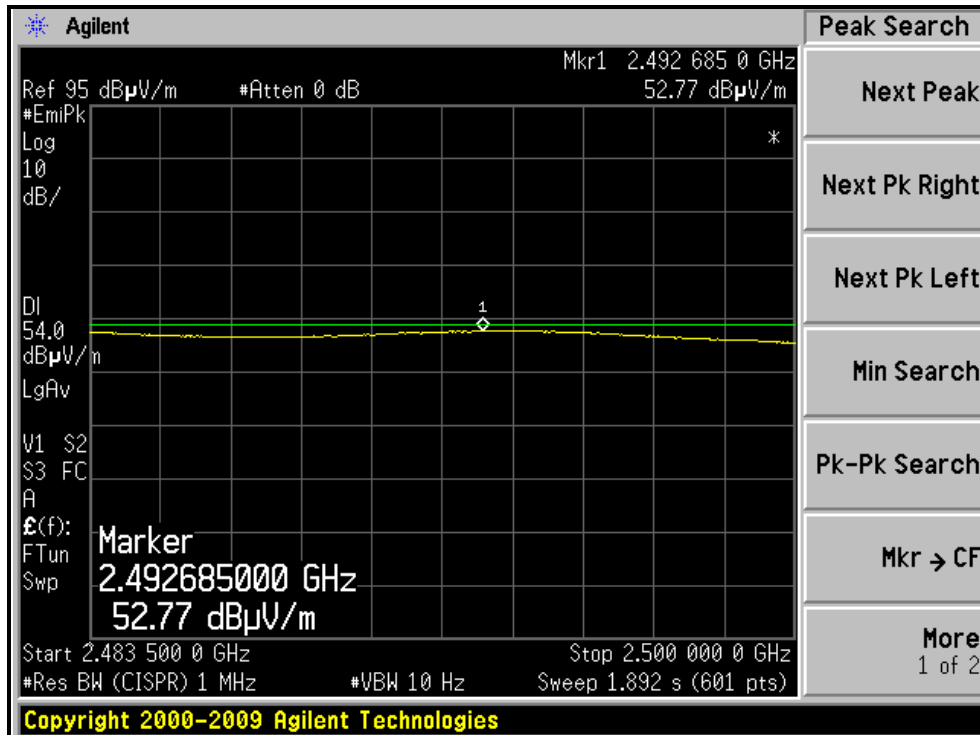
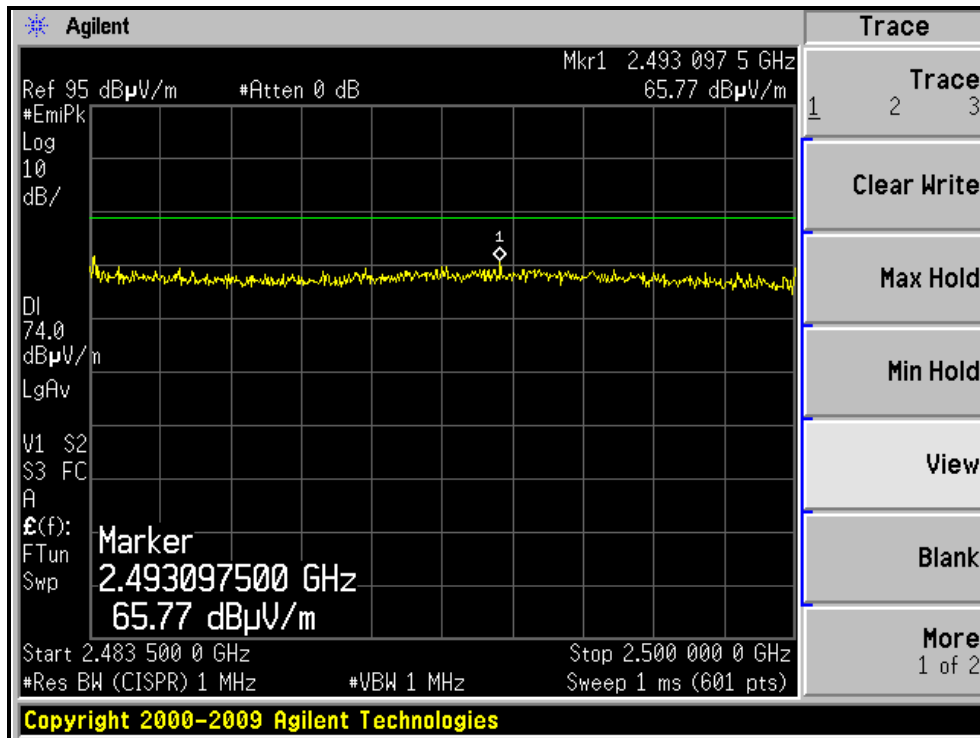





A D T

RESTRICTED BANDEDGE (802.11n (20MHz) MODE,CH11, VERTICAL )

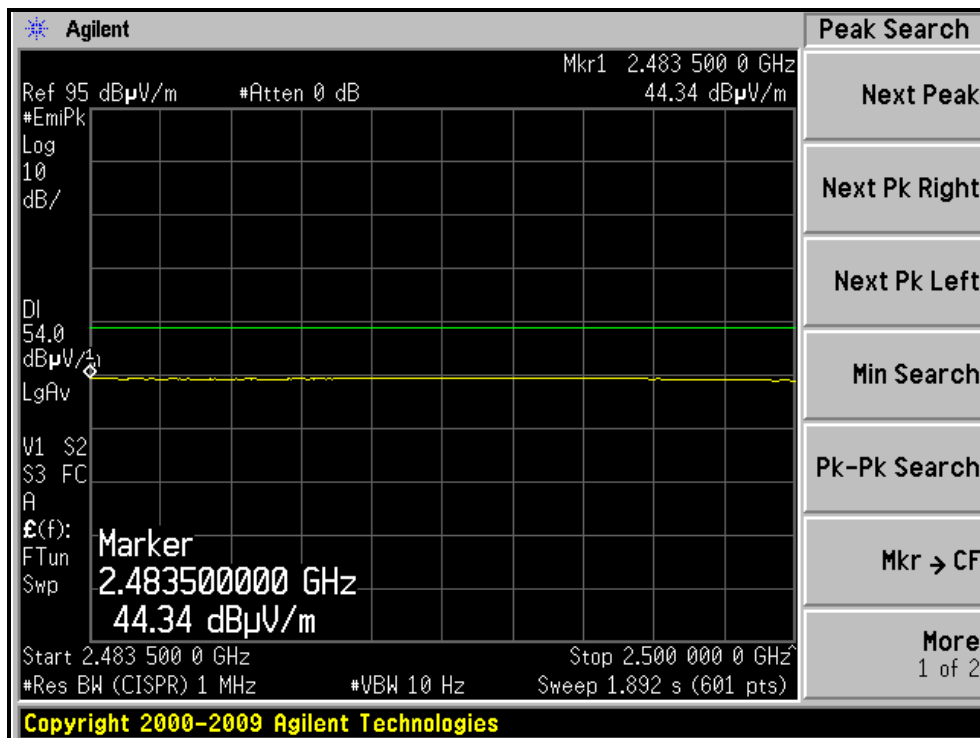
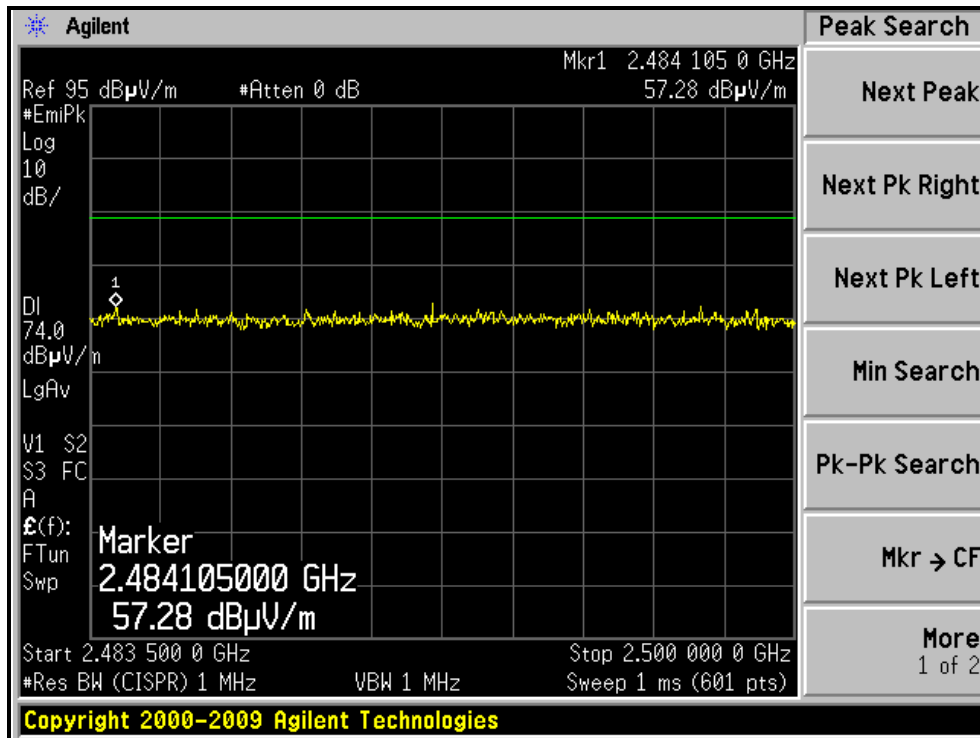



A D T

## 802.11n (40MHz) OFDM MODULATION

EUT TEST CONDITION		MEASUREMENT DETAIL	
CHANNEL	Channel 3	FREQUENCY RANGE	1 ~ 25GHz
INPUT POWER	120V / 60Hz	DETECTOR FUNCTION	Peak (PK) Average (AV)
ENVIRONMENTAL CONDITIONS	25deg. C, 65%RH 1003 hPa	TESTED BY	Frank Liu

ANTENNA POLARITY & TEST DISTANCE: HORIZONTAL AT 3 M								
NO.	FREQ. (MHz)	EMISSION LEVEL (dBuV/m)	LIMIT (dBuV/m)	MARGIN (dB)	ANTENNA HEIGHT (m)	TABLE ANGLE (Degree)	RAW VALUE (dBuV)	CORRECTION FACTOR (dB/m)
1	2390.00	66.5 PK	74.0	-7.5	1.00 H	253	35.29	31.21
2	2390.00	52.9 AV	54.0	-1.1	1.00 H	253	21.69	31.21
3	*2422.00	104.3 PK			1.00 H	253	73.00	31.30
4	*2422.00	94.1 AV			1.00 H	253	62.80	31.30
5	4844.00	48.6 PK	74.0	-25.4	1.13 H	96	9.10	39.50
6	4844.00	35.8 AV	54.0	-18.2	1.13 H	96	-3.70	39.50
7	7266.00	52.8 PK	74.0	-21.2	1.01 H	37	8.74	44.06
8	7266.00	41.3 AV	54.0	-12.7	1.01 H	37	-2.76	44.06
ANTENNA POLARITY & TEST DISTANCE: VERTICAL AT 3 M								
NO.	FREQ. (MHz)	EMISSION LEVEL (dBuV/m)	LIMIT (dBuV/m)	MARGIN (dB)	ANTENNA HEIGHT (m)	TABLE ANGLE (Degree)	RAW VALUE (dBuV)	CORRECTION FACTOR (dB/m)
1	2390.00	58.7 PK	74.0	-15.3	1.75 V	11	27.49	31.21
2	2390.00	45.9 AV	54.0	-8.1	1.75 V	11	14.69	31.21
3	*2422.00	92.3 PK			1.75 V	11	61.00	31.30
4	*2422.00	81.1 AV			1.75 V	11	49.80	31.30
5	4844.00	49.8 PK	74.0	-24.2	1.15 V	103	10.30	39.50
6	4844.00	36.1 AV	54.0	-17.9	1.15 V	103	-3.40	39.50
7	7266.00	53.2 PK	74.0	-20.8	1.21 V	119	9.14	44.06
8	7266.00	41.5 AV	54.0	-12.5	1.21 V	119	-2.56	44.06

- REMARKS:**
1. Emission level (dBuV/m) = Raw Value (dBuV) + Correction Factor (dB/m).
  2. Correction Factor (dB/m) = Antenna Factor (dB/m) + Cable Factor (dB).
  3. The other emission levels were very low against the limit.
  4. Margin value = Emission level – Limit value.
  5. “ \* “: Fundamental frequency.



A D T

EUT TEST CONDITION		MEASUREMENT DETAIL	
CHANNEL	Channel 6	FREQUENCY RANGE	1 ~ 25GHz
INPUT POWER	120V / 60Hz	DETECTOR FUNCTION	Peak (PK) Average (AV)
ENVIRONMENTAL CONDITIONS	25deg. C, 65%RH 1003 hPa	TESTED BY	Frank Liu

**ANTENNA POLARITY & TEST DISTANCE: HORIZONTAL AT 3 M**

NO.	FREQ. (MHz)	EMISSION LEVEL (dBuV/m)	LIMIT (dBuV/m)	MARGIN (dB)	ANTENNA HEIGHT (m)	TABLE ANGLE (Degree)	RAW VALUE (dBuV)	CORRECTION FACTOR (dB/m)
1	2390.00	67.2 PK	74.0	-6.8	1.00 H	254	35.99	31.21
2	2390.00	52.4 AV	54.0	-1.6	1.00 H	254	21.19	31.21
3	*2437.00	107.3 PK			1.00 H	265	75.96	31.34
4	*2437.00	97.1 AV			1.00 H	265	65.76	31.34
5	2483.50	65.7 PK	74.0	-8.3	1.00 H	255	34.24	31.46
6	2483.50	52.9 AV	54.0	-1.1	1.00 H	255	21.44	31.46
7	4874.00	48.7 PK	74.0	-25.3	1.17 H	94	9.08	39.62
8	4874.00	35.7 AV	54.0	-18.3	1.17 H	94	-3.92	39.62
9	7311.00	53.2 PK	74.0	-20.8	1.00 H	36	9.10	44.10
10	7311.00	41.5 AV	54.0	-12.5	1.00 H	36	-2.60	44.10

**ANTENNA POLARITY & TEST DISTANCE: VERTICAL AT 3 M**

NO.	FREQ. (MHz)	EMISSION LEVEL (dBuV/m)	LIMIT (dBuV/m)	MARGIN (dB)	ANTENNA HEIGHT (m)	TABLE ANGLE (Degree)	RAW VALUE (dBuV)	CORRECTION FACTOR (dB/m)
1	*2437.00	95.7 PK			1.80 V	24	64.36	31.34
2	*2437.00	84.5 AV			1.80 V	24	53.16	31.34
3	4874.00	49.9 PK	74.0	-24.1	1.09 V	100	10.28	39.62
4	4874.00	36.1 AV	54.0	-17.9	1.09 V	100	-3.52	39.62
5	7311.00	52.9 PK	74.0	-21.1	1.22 V	114	8.80	44.10
6	7311.00	41.3 AV	54.0	-12.7	1.22 V	114	-2.80	44.10

- REMARKS:**
1. Emission level (dBuV/m) = Raw Value (dBuV) + Correction Factor (dB/m).
  2. Correction Factor (dB/m) = Antenna Factor (dB/m) + Cable Factor (dB).
  3. The other emission levels were very low against the limit.
  4. Margin value = Emission level – Limit value.
  5. “ \* “: Fundamental frequency.



A D T

EUT TEST CONDITION		MEASUREMENT DETAIL	
CHANNEL	Channel 9	FREQUENCY RANGE	1 ~ 25GHz
INPUT POWER	120V / 60Hz	DETECTOR FUNCTION	Peak (PK) Average (AV)
ENVIRONMENTAL CONDITIONS	25deg. C, 65%RH 1003 hPa	TESTED BY	Frank Liu

**ANTENNA POLARITY & TEST DISTANCE: HORIZONTAL AT 3 M**

NO.	FREQ. (MHz)	EMISSION LEVEL (dBuV/m)	LIMIT (dBuV/m)	MARGIN (dB)	ANTENNA HEIGHT (m)	TABLE ANGLE (Degree)	RAW VALUE (dBuV)	CORRECTION FACTOR (dB/m)
1	*2452.00	103.5 PK			1.00 H	254	72.12	31.38
2	*2452.00	93.6 AV			1.00 H	254	62.22	31.38
3	2483.50	63.5 PK	74.0	-10.5	1.00 H	254	32.04	31.46
4	2483.50	52.0 AV	54.0	-2.0	1.00 H	254	20.54	31.46
5	4904.00	51.2 PK	74.0	-22.8	1.13 H	76	11.46	39.74
6	4904.00	37.6 AV	54.0	-16.4	1.13 H	76	-2.14	39.74
7	7356.00	52.6 PK	74.0	-21.4	1.04 H	50	8.45	44.15
8	7356.00	41.4 AV	54.0	-12.6	1.04 H	50	-2.75	44.15

**ANTENNA POLARITY & TEST DISTANCE: VERTICAL AT 3 M**

NO.	FREQ. (MHz)	EMISSION LEVEL (dBuV/m)	LIMIT (dBuV/m)	MARGIN (dB)	ANTENNA HEIGHT (m)	TABLE ANGLE (Degree)	RAW VALUE (dBuV)	CORRECTION FACTOR (dB/m)
1	*2452.00	91.2 PK			1.67 V	11	59.82	31.38
2	*2452.00	80.1 AV			1.67 V	11	48.72	31.38
3	2483.50	56.7 PK	74.0	-17.3	1.67 V	11	25.24	31.46
4	2483.50	44.6 AV	54.0	-9.4	1.67 V	11	13.14	31.46
5	4904.00	52.4 PK	74.0	-21.6	1.16 V	113	12.66	39.74
6	4904.00	38.2 AV	54.0	-15.8	1.16 V	113	-1.54	39.74
7	7356.00	54.2 PK	74.0	-19.8	1.30 V	135	10.05	44.15
8	7356.00	42.2 AV	54.0	-11.8	1.30 V	135	-1.95	44.15

- REMARKS:**
1. Emission level (dBuV/m) = Raw Value (dBuV) + Correction Factor (dB/m).
  2. Correction Factor (dB/m) = Antenna Factor (dB/m) + Cable Factor (dB).
  3. The other emission levels were very low against the limit.
  4. Margin value = Emission level – Limit value.
  5. “ \* “: Fundamental frequency.



A D T

RESTRICTED BANDEDGE (802.11n (40MHz) MODE,CH3, HORIZONTAL )

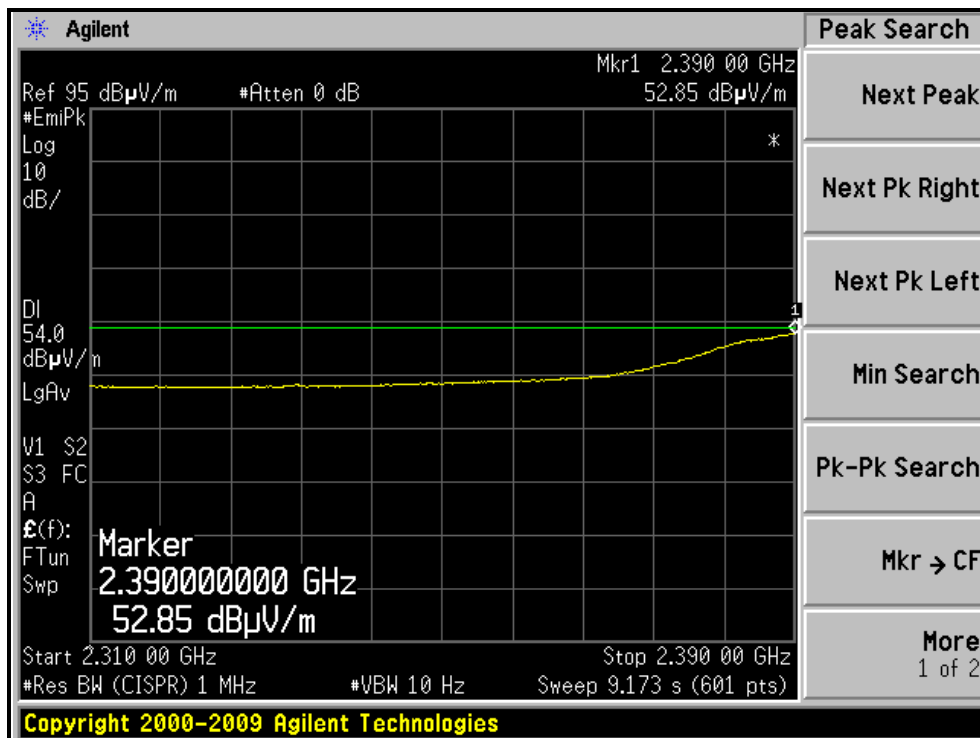
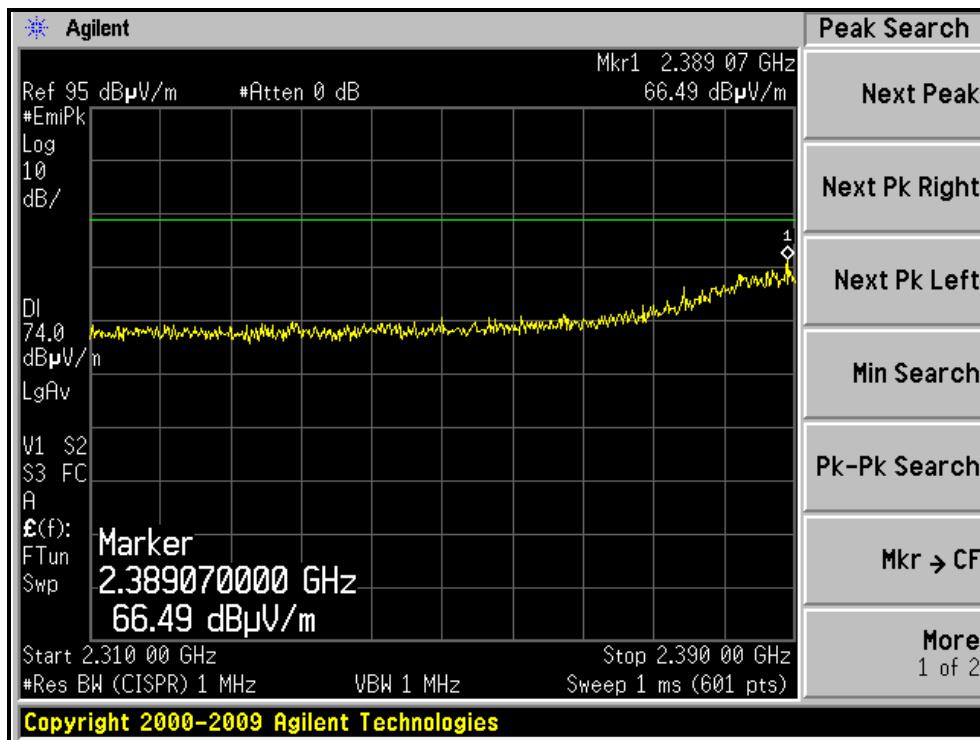

RESTRICTED BANDEDGE (802.11n (40MHz) MODE,CH3, VERTICAL )

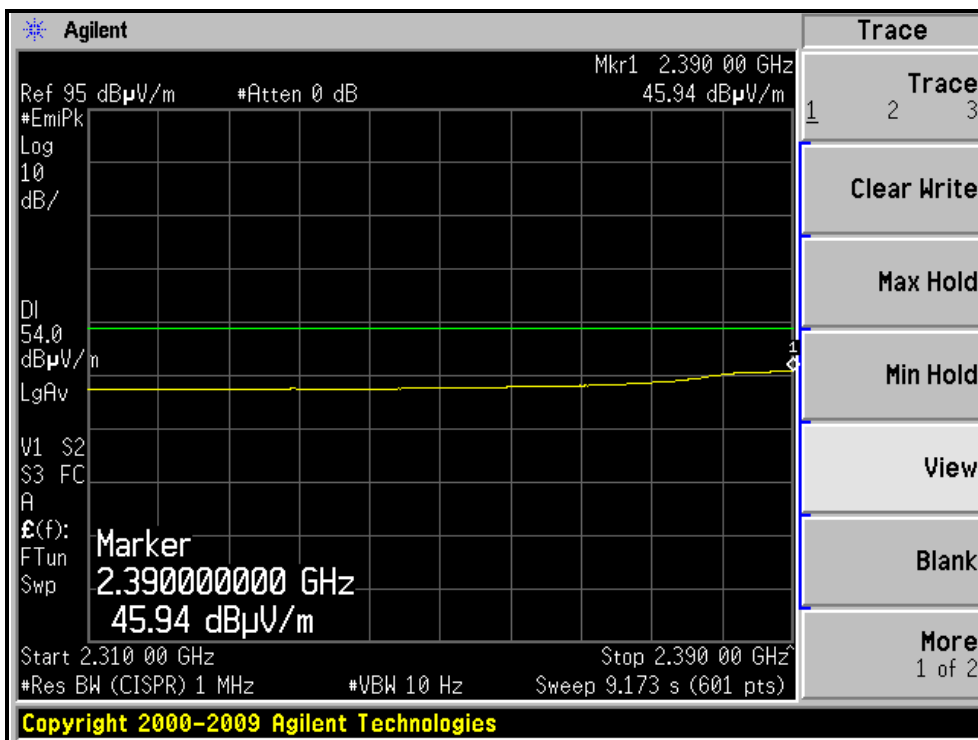
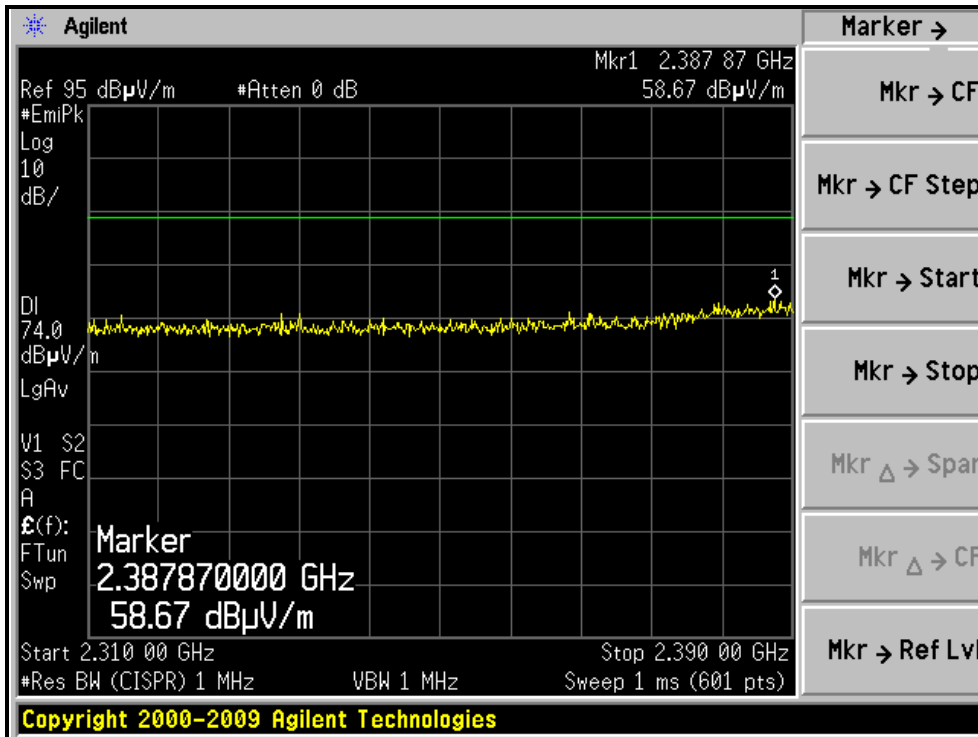

RESTRICTED BANDEDGE (802.11n (40MHz) MODE,CH9, HORIZONTAL )

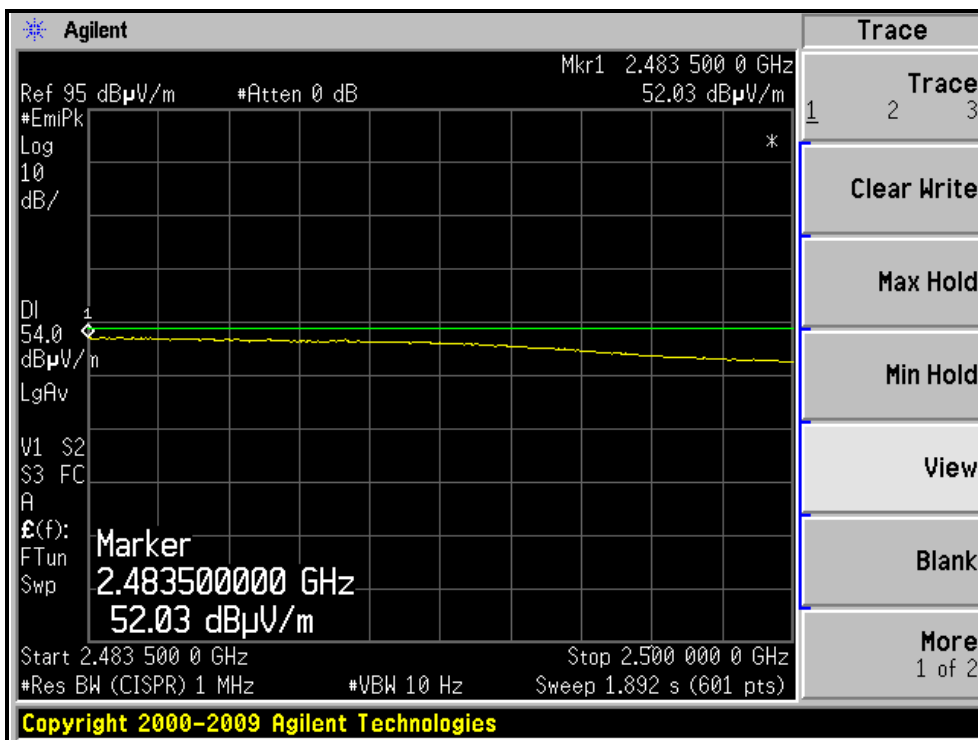
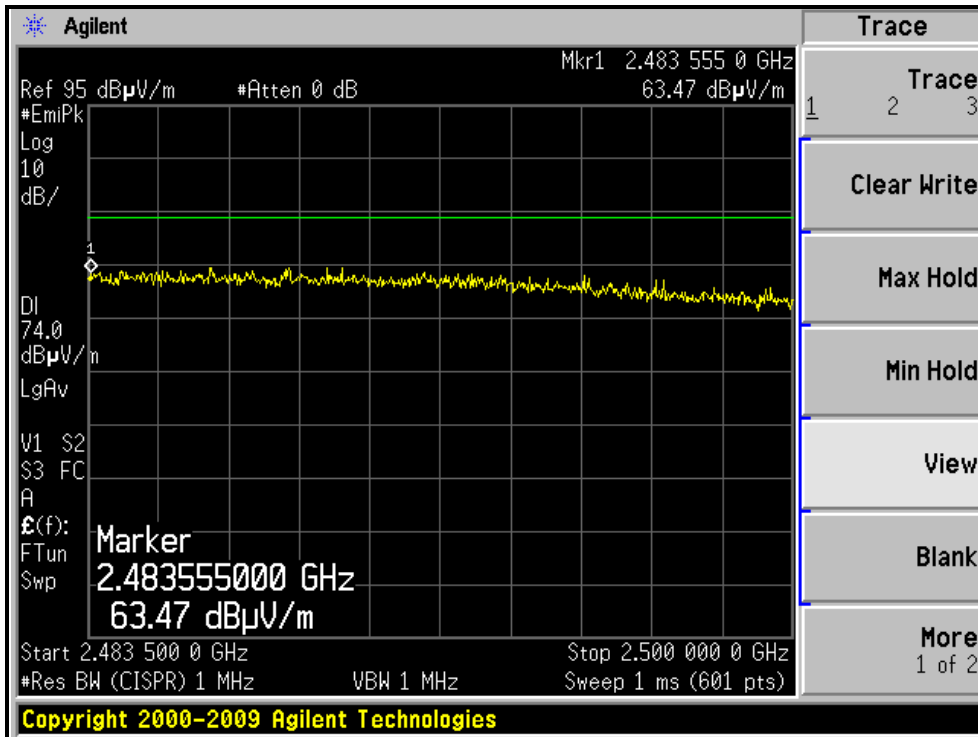

RESTRICTED BANDEDGE (802.11n (40MHz) MODE,CH9, VERTICAL )

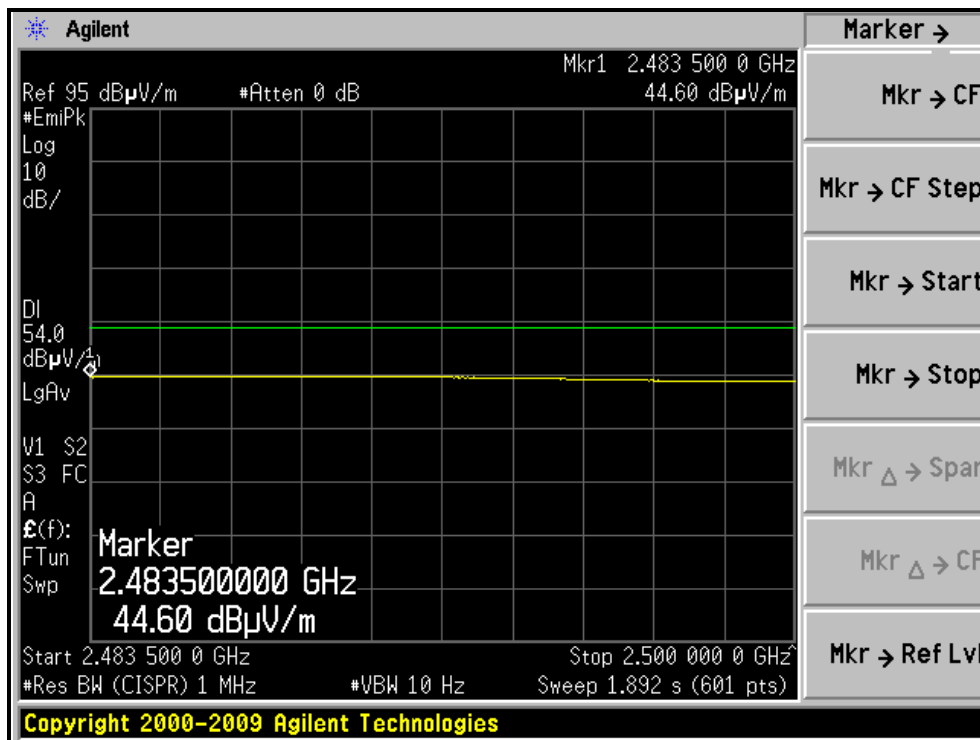
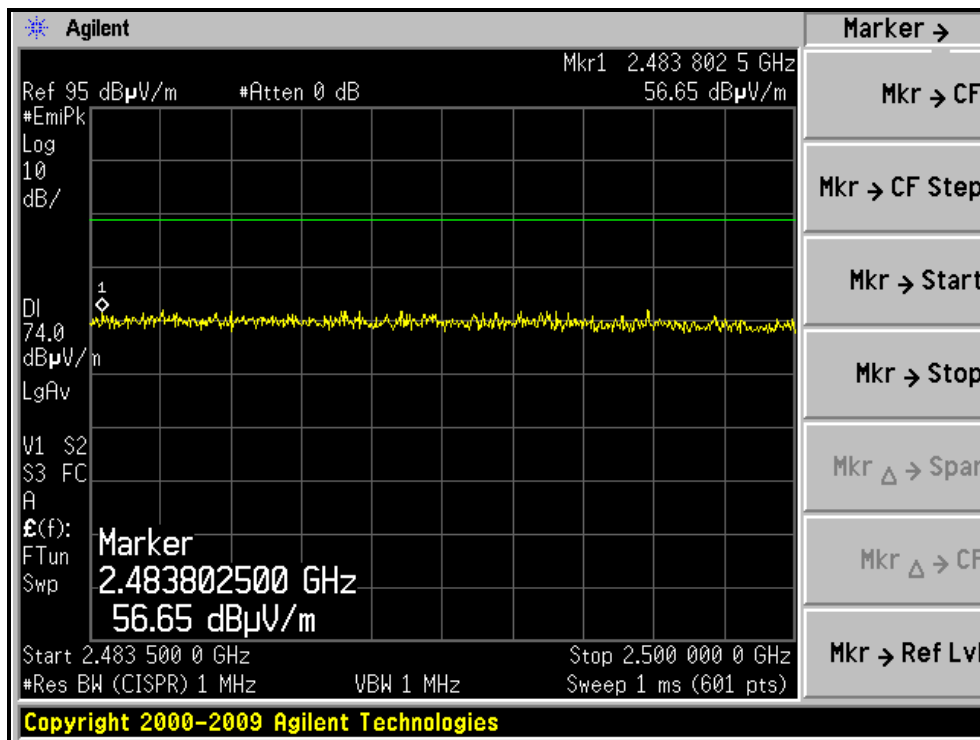



### 4.3 6dB BANDWIDTH MEASUREMENT

#### 4.3.1 LIMITS OF 6dB BANDWIDTH MEASUREMENT

The minimum of 6dB Bandwidth Measurement is 0.5 MHz.

#### 4.3.2 TEST INSTRUMENTS

Test date: June 02, 2011

DESCRIPTION & MANUFACTURER	MODEL NO.	SERIAL NO.	CALIBRATED DATE	CALIBRATED UNTIL
Spectrum Analyzer R&S	FSP 40	100060	May 11, 2011	May 10, 2012

**NOTE:**

1. The calibration interval of the above test instruments is 12 months and the calibrations are traceable to NML/ROC and NIST/USA.

#### 4.3.3 TEST PROCEDURE

The transmitter output was connected to the spectrum analyzer through an attenuator. The bandwidth of the fundamental frequency was measured by spectrum analyzer with 100kHz RBW and 300kHz VBW. The 6dB bandwidth is defined as the total spectrum the power of which is higher than peak power minus 6dB.

#### 4.3.4 DEVIATION FROM TEST STANDARD

No deviation

#### 4.3.5 TEST SETUP



#### 4.3.6 EUT OPERATING CONDITIONS

The software provided by client to enable the EUT under transmission condition continuously at lowest, middle and highest channel frequencies individually.



A D T

### 4.3.7 TEST RESULTS

#### 802.11b DSSS MODULATION:

CHANNEL	CHANNEL FREQUENCY (MHz)	6dB BANDWIDTH (MHz)	MINIMUM LIMIT (MHz)	PASS / FAIL
1	2412	8.77	0.5	PASS
6	2437	7.69	0.5	PASS
11	2462	8.16	0.5	PASS

CH1

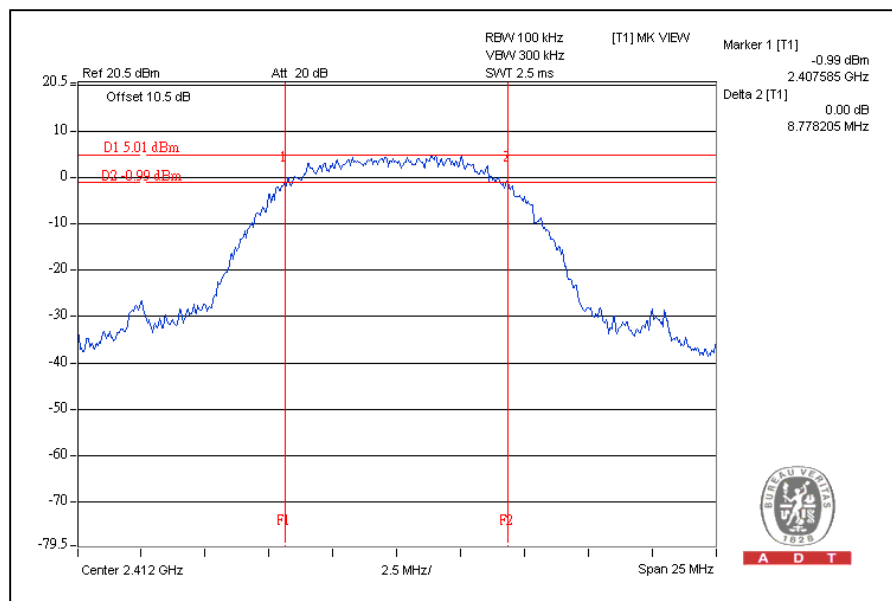



A D T

### 802.11g OFDM MODULATION:

CHANNEL	CHANNEL FREQUENCY (MHz)	6dB BANDWIDTH (MHz)	MINIMUM LIMIT (MHz)	PASS / FAIL
1	2412	15.07	0.5	PASS
6	2437	15.09	0.5	PASS
11	2462	14.49	0.5	PASS

### CH6

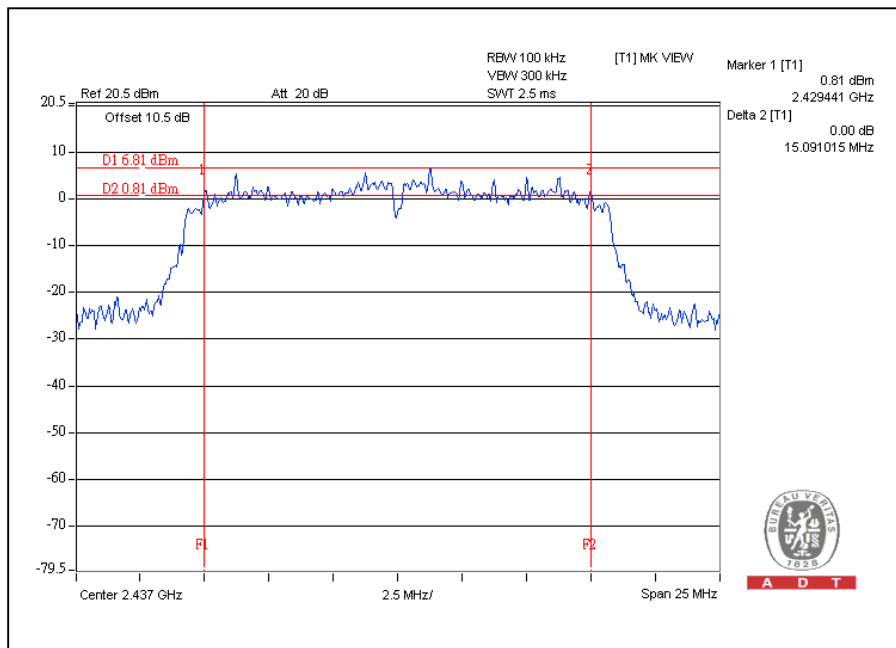



A D T

### 802.11n (20MHz) OFDM MODULATION:

CHANNEL	CHANNEL FREQUENCY (MHz)	6dB BANDWIDTH (MHz)	MINIMUM LIMIT (MHz)	PASS / FAIL
1	2412	15.05	0.5	PASS
6	2437	13.32	0.5	PASS
11	2462	12.58	0.5	PASS

CH1

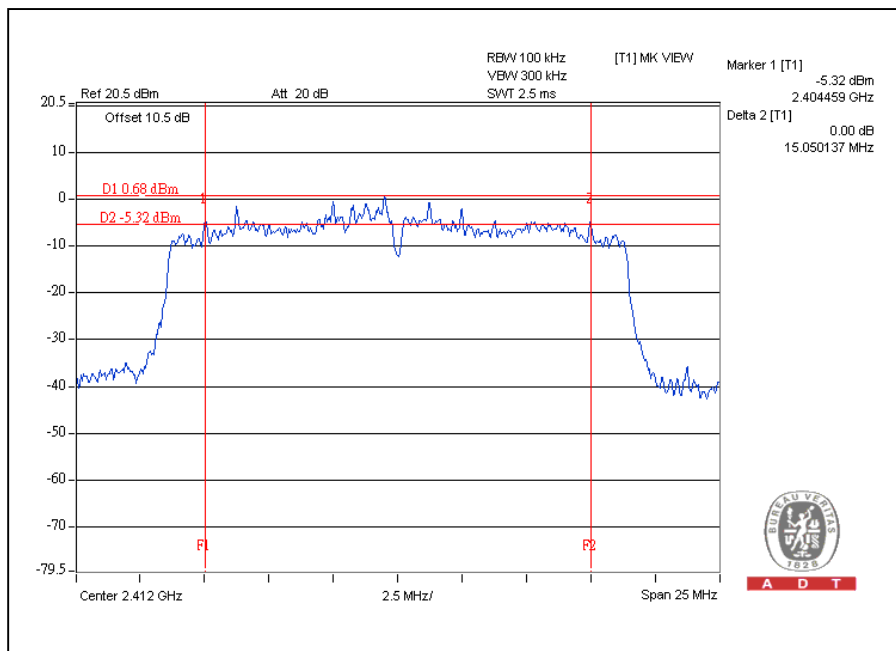



A D T

### 802.11n (40MHz) OFDM MODULATION:

CHANNEL	CHANNEL FREQUENCY (MHz)	6dB BANDWIDTH (MHz)	MINIMUM LIMIT (MHz)	PASS / FAIL
3	2422	32.67	0.5	PASS
6	2437	31.47	0.5	PASS
9	2452	33.97	0.5	PASS

CH9

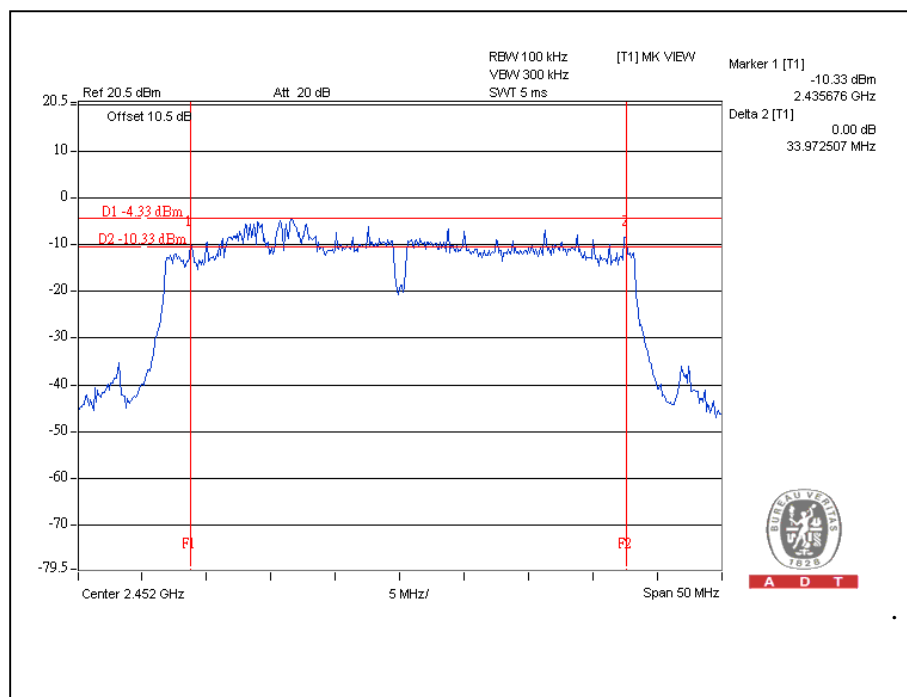

#### 4.4 MAXIMUM PEAK OUTPUT POWER

##### 4.4.1 LIMITS OF MAXIMUM PEAK OUTPUT POWER MEASUREMENT

The Maximum Peak Output Power Measurement is 30dBm.

##### 4.4.2 INSTRUMENTS

DESCRIPTION & MANUFACTURER	MODEL NO.	SERIAL NO.	CALIBRATED DATE	CALIBRATED UNTIL
Anritsu Power Meter	ML2495A	0824006	May 04, 2011	May 03, 2012
Pulse Power Sensor	MA2411B	0738172	May 03, 2011	May 02, 2012

**NOTE:**

The calibration interval of the above test instruments is 12 months and the calibrations are traceable to NML/ROC and NIST/USA.

##### 4.4.3 TEST PROCEDURES

1. The transmitter output was connected to the power meter through an attenuator; the bandwidth of the fundamental frequency was measured with the power meter.
2. Record the power level.

##### 4.4.4 DEVIATION FROM TEST STANDARD

No deviation

##### 4.4.5 TEST SETUP

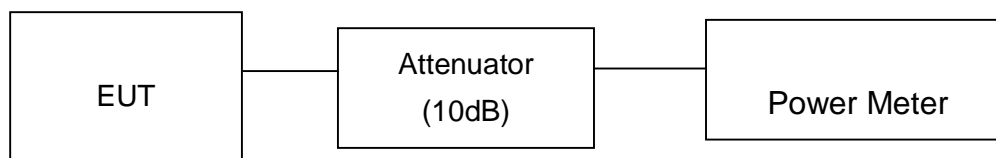

##### 4.4.6 EUT OPERATING CONDITIONS

Same as Item 4.3.6



#### 4.4.7 TEST RESULTS

##### 802.11b DSSS MODULATION:

CHANNEL	CHANNEL FREQUENCY (MHz)	PEAK POWER OUTPUT (mW)	PEAK POWER OUTPUT (dBm)	PEAK POWER LIMIT (dBm)	PASS / FAIL
1	2412	67.6	18.3	30	PASS
6	2437	53.7	17.3	30	PASS
11	2462	41.7	16.2	30	PASS

##### 802.11g OFDM MODULATION:

CHANNEL	CHANNEL FREQUENCY (MHz)	PEAK POWER OUTPUT (mW)	PEAK POWER OUTPUT (dBm)	PEAK POWER LIMIT (dBm)	PASS / FAIL
1	2412	81.3	19.1	30	PASS
6	2437	263.0	24.2	30	PASS
11	2462	85.1	19.3	30	PASS

##### 802.11n (20MHz) OFDM MODULATION:

CHANNEL	CHANNEL FREQUENCY (MHz)	PEAK POWER OUTPUT (dBm)		TOTAL PEAK POWER (mW)	TOTAL PEAK POWER (dBm)	PEAK POWER LIMIT (dBm)	PASS / FAIL
		CHAIN(0)	CHAIN(1)				
1	2412	18.6	18.0	135.5	21.3	30	PASS
6	2437	24.6	24.7	583.5	27.7	30	PASS
11	2462	18.6	18.2	138.5	21.4	30	PASS

##### 802.11n (40MHz) OFDM MODULATION:

CHANNEL	CHANNEL FREQUENCY (MHz)	PEAK POWER OUTPUT (dBm)		TOTAL PEAK POWER (mW)	TOTAL PEAK POWER (dBm)	PEAK POWER LIMIT (dBm)	PASS / FAIL
		CHAIN(0)	CHAIN(1)				
3	2422	18.1	18.2	130.6	21.2	30	PASS
6	2437	21.7	21.2	279.7	24.5	30	PASS
9	2452	18.3	18.2	133.7	21.3	30	PASS

## 4.5 POWER SPECTRAL DENSITY MEASUREMENT

### 4.5.1 LIMITS OF POWER SPECTRAL DENSITY MEASUREMENT

The Maximum of Power Spectral Density Measurement is 8dBm.

### 4.5.2 TEST INSTRUMENTS

DESCRIPTION & MANUFACTURER	MODEL NO.	SERIAL NO.	CALIBRATED DATE	CALIBRATED UNTIL
Spectrum Analyzer R&S	FSP 40	100060	May 11, 2011	May 10, 2012

**NOTE:**

1. The calibration interval of the above test instruments is 12 months and the calibrations are traceable to NML/ROC and NIST/USA.

### 4.5.3 TEST PROCEDURE

The transmitter output was connected to the spectrum analyzer through an attenuator, the bandwidth of the fundamental frequency was measured with the spectrum analyzer using 3kHz RBW and 30kHz VBW, set sweep time = span/3kHz. The power spectral density was measured and recorded.

The sweep time is allowed to be longer than span/3kHz for a full response of the mixer in the spectrum analyzer.

### 4.5.4 DEVIATION FROM TEST STANDARD

No deviation

### 4.5.5 TEST SETUP

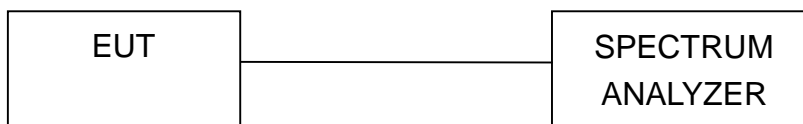

### 4.5.6 EUT OPERATING CONDITION

Same as Item 4.3.6





A D T

### 4.5.7 TEST RESULTS

#### 802.11b DSSS MODULATION:

CHANNEL	CHANNEL FREQUENCY (MHz )	RF POWER LEVEL IN 3kHz BW (dBm)	MAXIMUM LIMIT (dBm)	PASS / FAIL
1	2412	-7.9	8	PASS
6	2437	-8.2	8	PASS
11	2462	-11.0	8	PASS

CH1

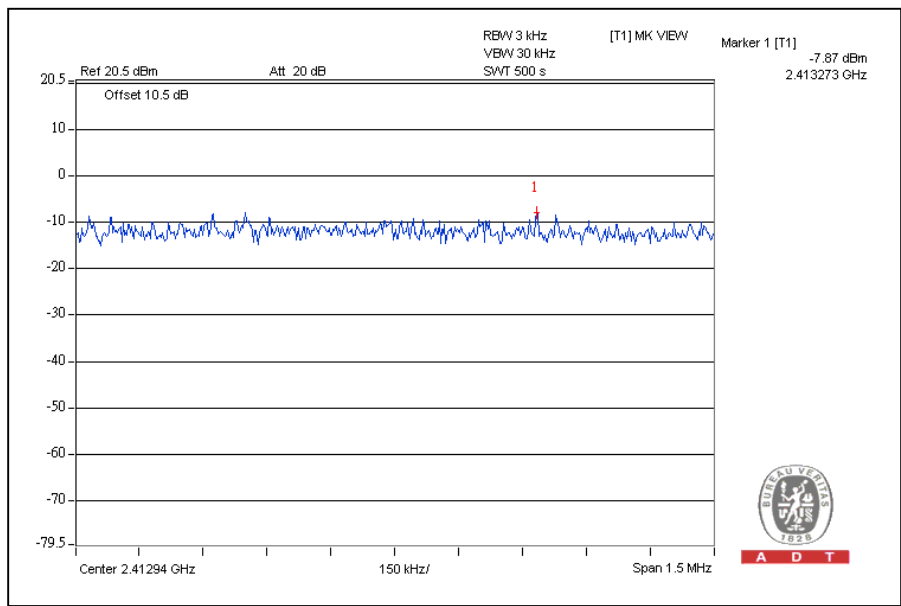



A D T

### 802.11g OFDM MODULATION:

CHANNEL	CHANNEL FREQUENCY (MHz )	RF POWER LEVEL IN 3kHz BW (dBm)	MAXIMUM LIMIT (dBm)	PASS / FAIL
1	2412	-13.3	8	PASS
6	2437	-7.5	8	PASS
11	2462	-14.9	8	PASS

### CH6

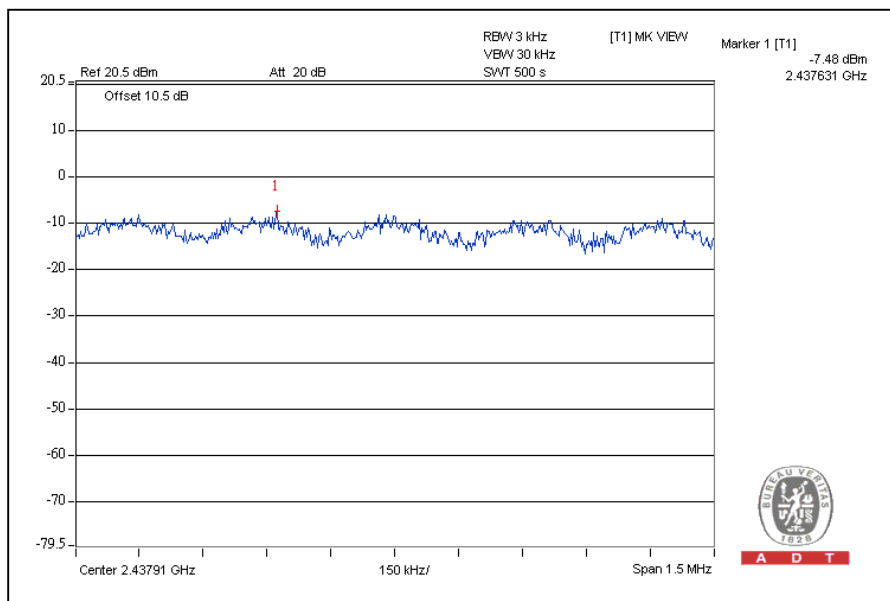



A D T

### 802.11n (20MHz) OFDM MODULATION:

CHANNEL	CHANNEL FREQUENCY (MHz)	RF POWER LEVEL IN 3kHz BW (dBm)		TOTAL POWER Density (dBm)	MAXIMUM LIMIT (dBm)	PASS / FAIL
		Chain(0)	CHAIN(1)			
1	2412	-14.9	-16.5	-12.6	8	PASS
6	2437	-7.8	-8.6	-5.2	8	PASS
11	2462	-15.5	-16.0	-12.7	8	PASS

For Chain(0): CH6

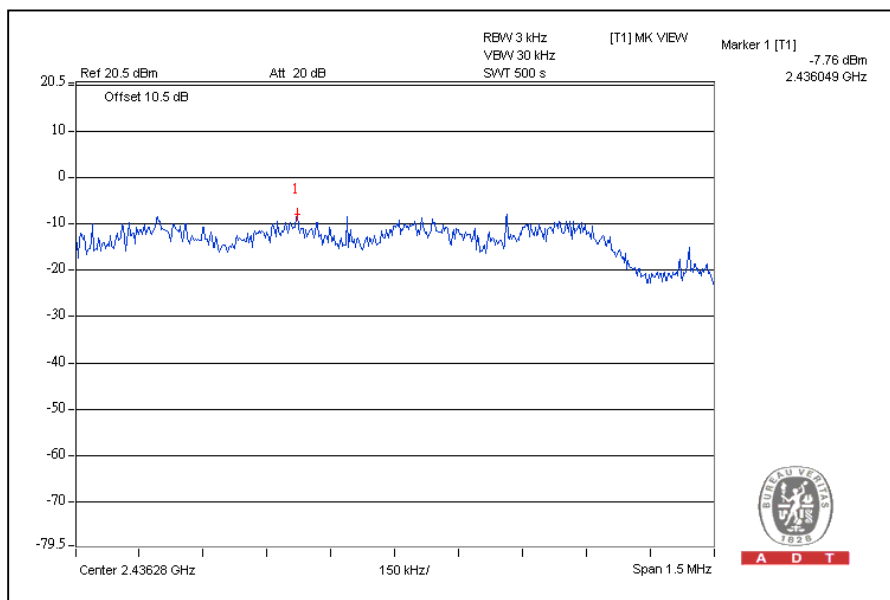



A D T

### 802.11n (40MHz) OFDM MODULATION:

CHANNEL	CHANNEL FREQUENCY (MHz)	RF POWER LEVEL IN 3kHz BW (dBm)		TOTAL POWER DENSITY (dBm)	MAXIMUM LIMIT (dBm)	PASS / FAIL
		CHAIN(0)	CHAIN(1)			
3	2422	-16.3	-19.9	-14.7	8	PASS
6	2437	-16.1	-15.4	-12.7	8	PASS
9	2452	-17.3	-19.8	-15.4	8	PASS

For Chain(1): CH6

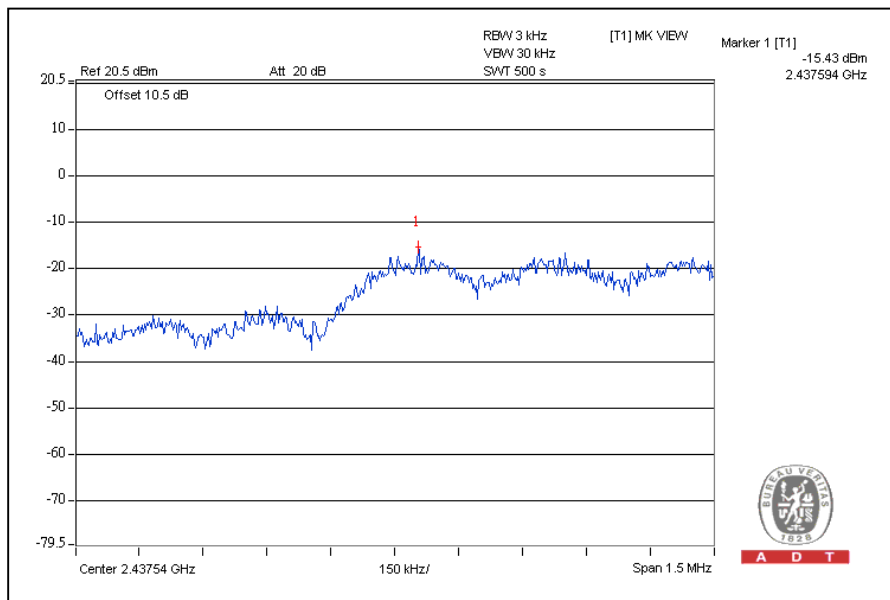

## 4.6 CONDUCTED OUT-BAND EMISSION MEASUREMENT

### 4.6.1 LIMITS OF CONDUCTED OUT-BAND EMISSION MEASUREMENT

Below  $-20\text{dB}$  of the highest emission level of operating band (in 100kHz Resolution Bandwidth).

### 4.6.2 TEST INSTRUMENTS

Test date: June 02, 2011

DESCRIPTION & MANUFACTURER	MODEL NO.	SERIAL NO.	CALIBRATED DATE	CALIBRATED UNTIL
Spectrum Analyzer R&S	FSP 40	100060	May 11, 2011	May 10, 2012

**NOTE:**

1. The calibration interval of the above test instruments is 12 months and the calibrations are traceable to NML/ROC and NIST/USA.

### 4.6.3 TEST PROCEDURE

The transmitter output was connected to the spectrum analyzer via a low loss cable. Set RBW of spectrum analyzer to 100kHz and VBW of spectrum analyzer to 300kHz with suitable frequency span including 100 MHz or 200 MHz bandwidth from band edge. The band edges was measured and recorded.

The spectrum plots (RBW = 100kHz, VBW = 300kHz) are attached on the following pages.

### 4.6.4 DEVIATION FROM TEST STANDARD

No deviation

### 4.6.5 EUT OPERATING CONDITION

Same as Item 4.3.6

### 4.6.6 TEST RESULTS

The spectrum plots are attached on the following images. D1 line indicates the highest level, and D2 line indicates the 20dB offset below D1. It shows compliance with the requirement in part 15.247(d).

## 802.11b DSSS MODULATION:

CH1

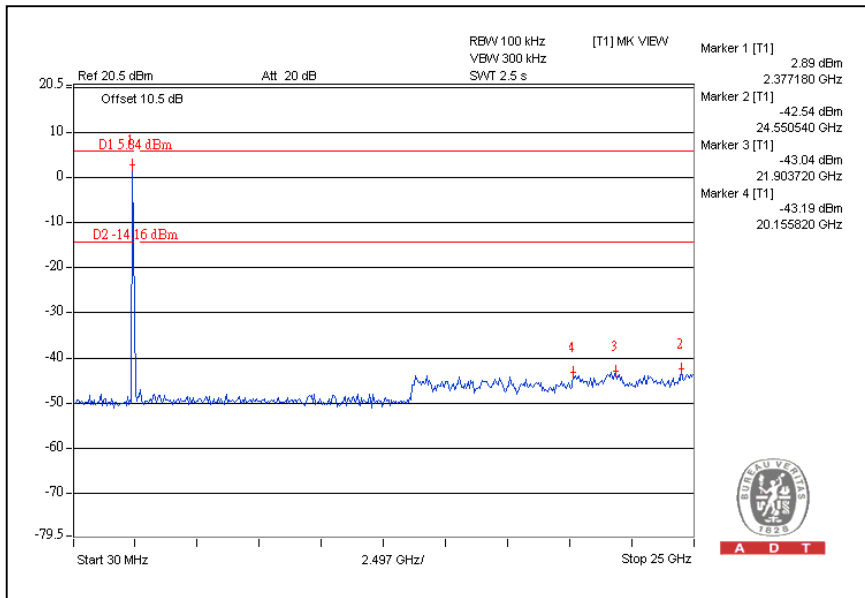
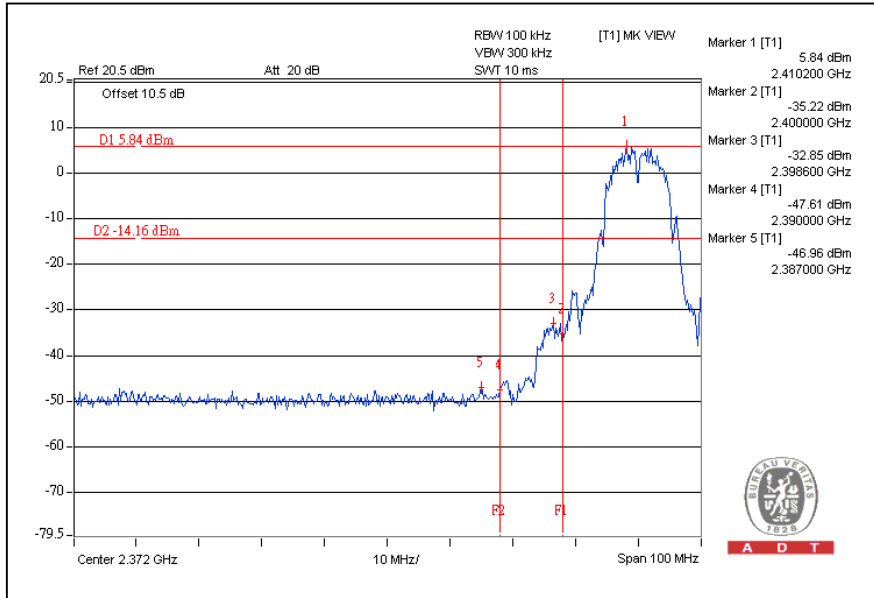



A D T

# CH11

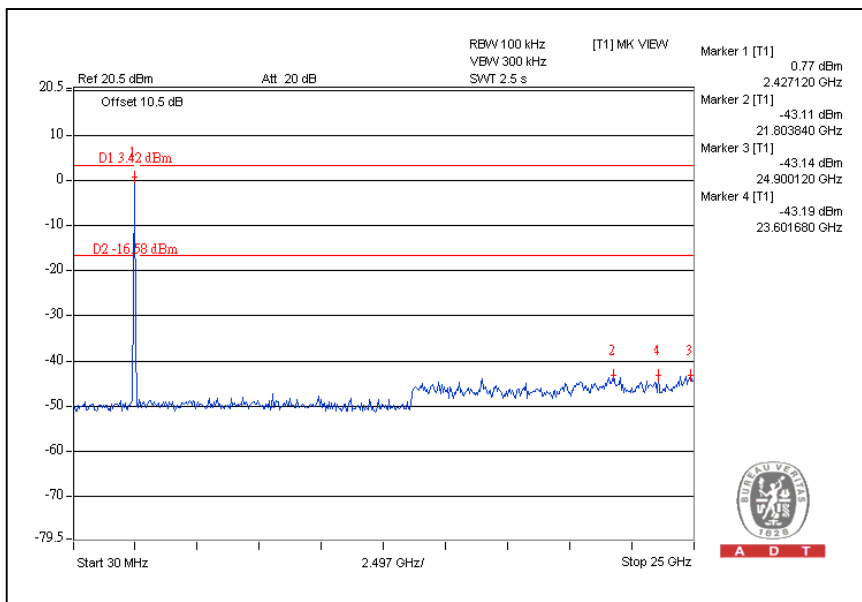
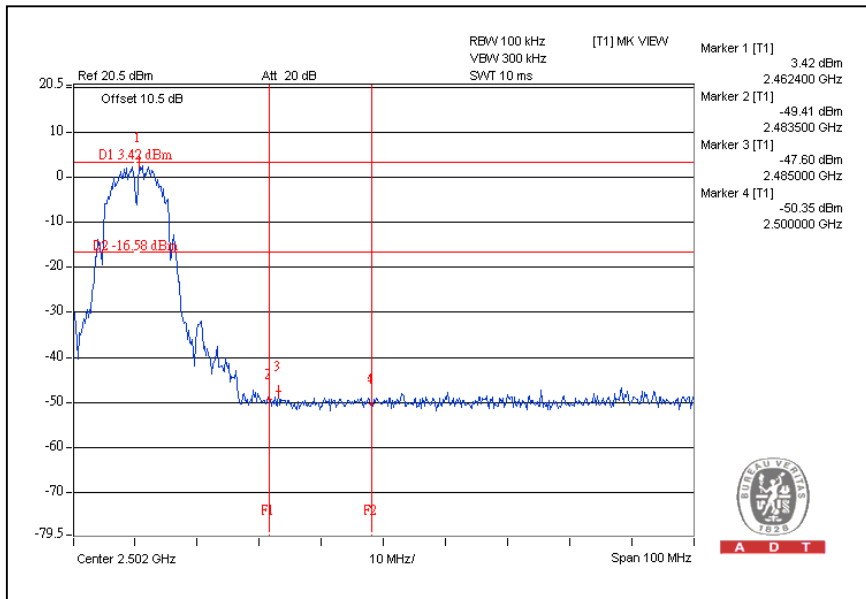

## 802.11g OFDM MODULATION:

CH1

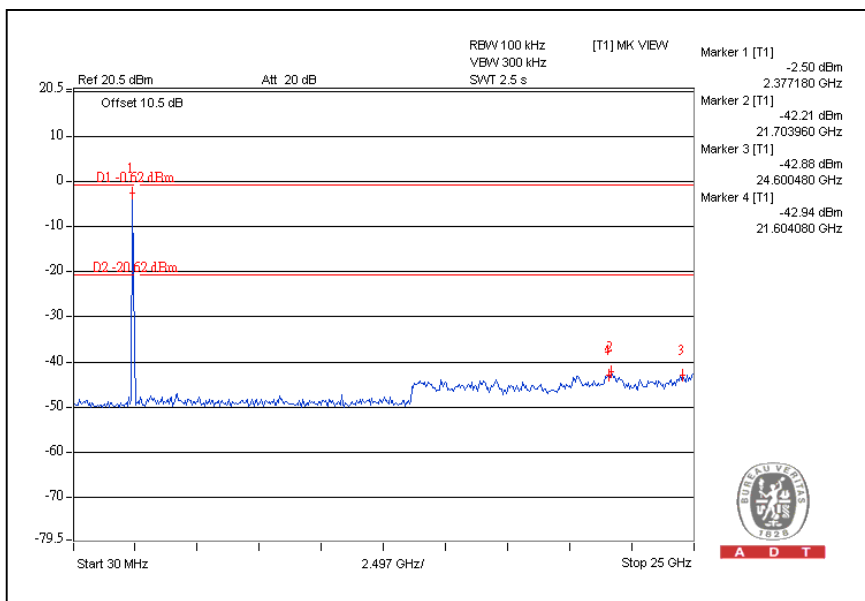
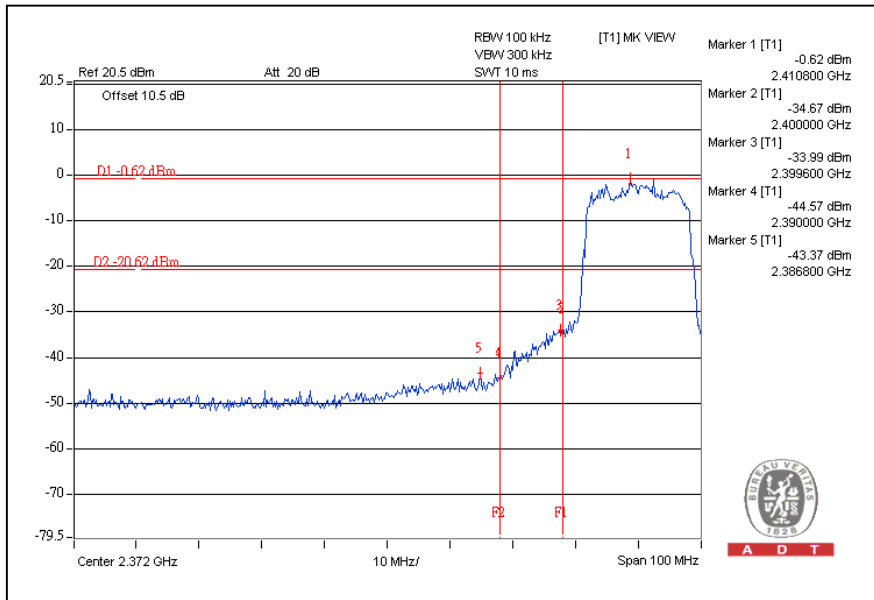





A D T

# CH11

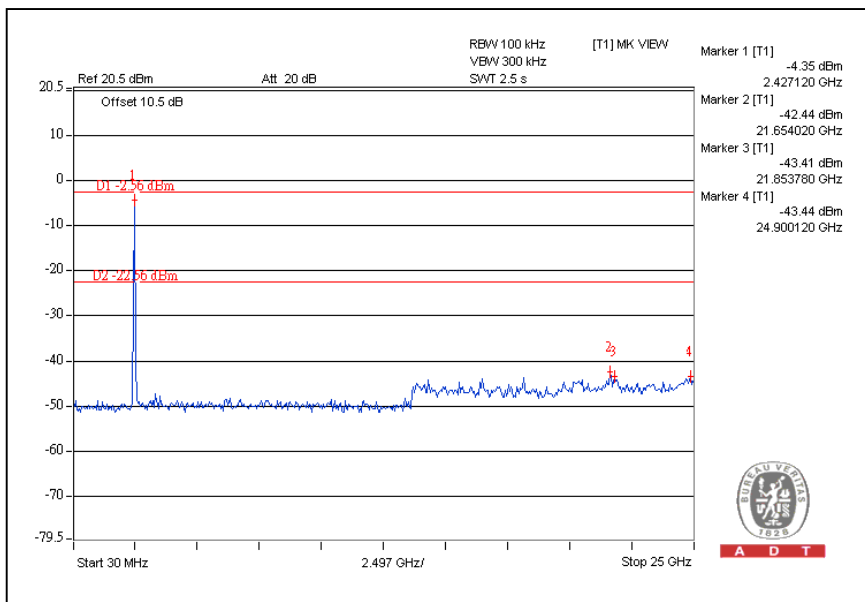
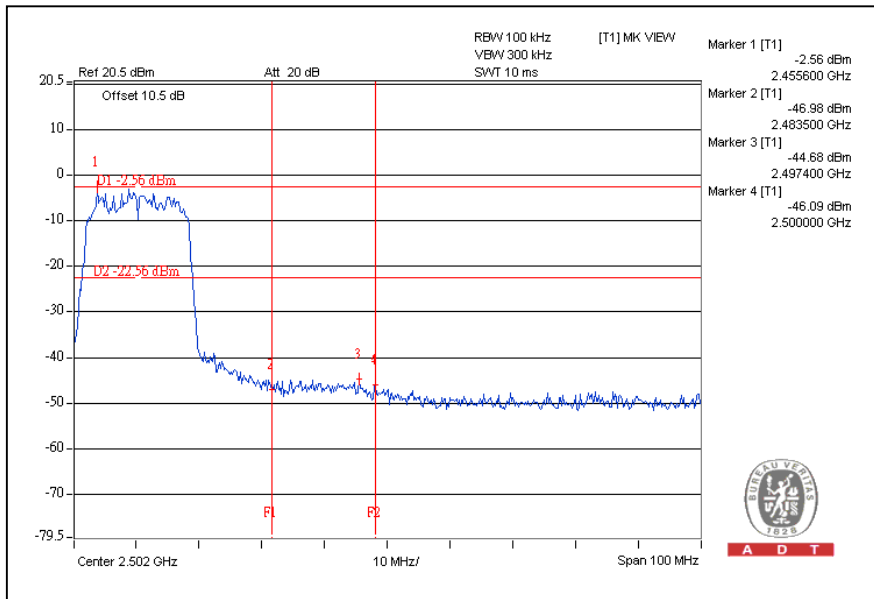



A D T

## 802.11n (20MHz) OFDM MODULATION:

For Chain(0)

CH1

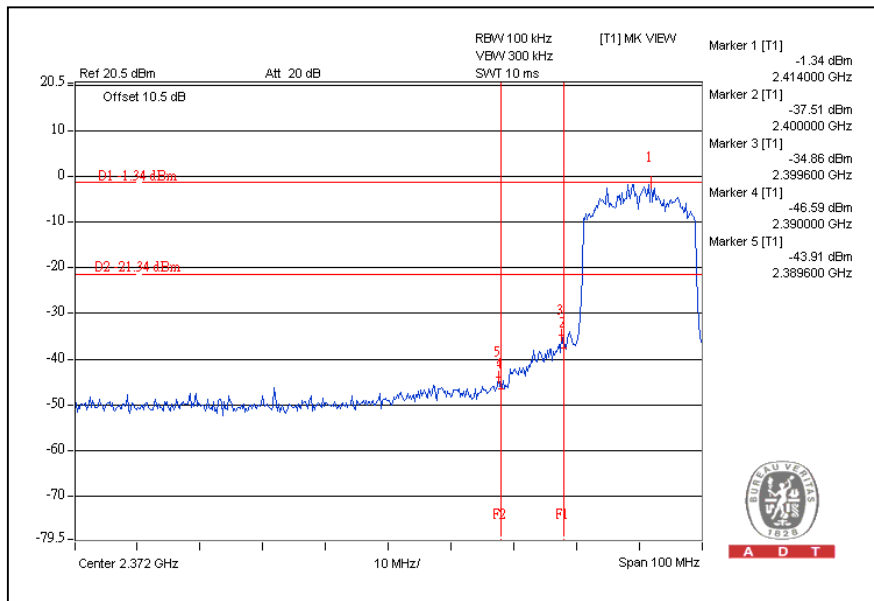

A D T

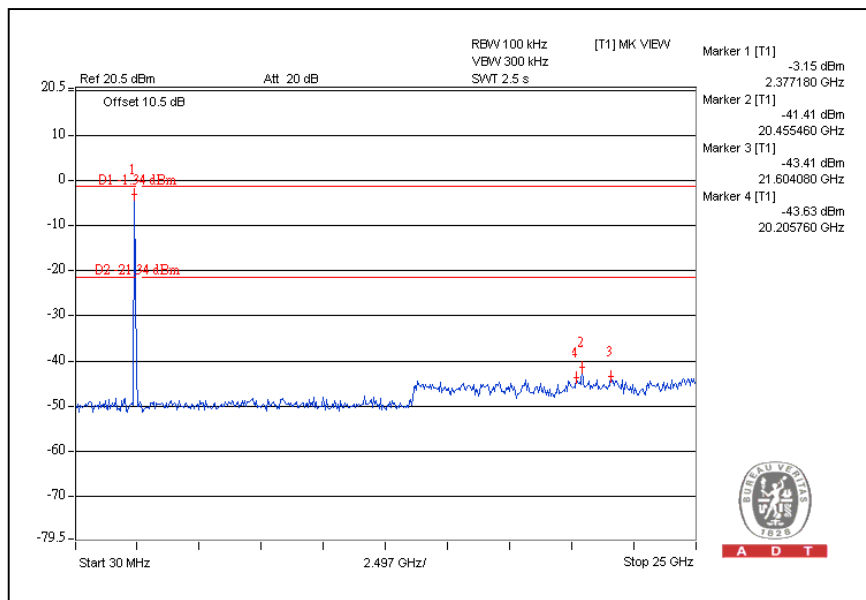

A D T



A D T

# CH11

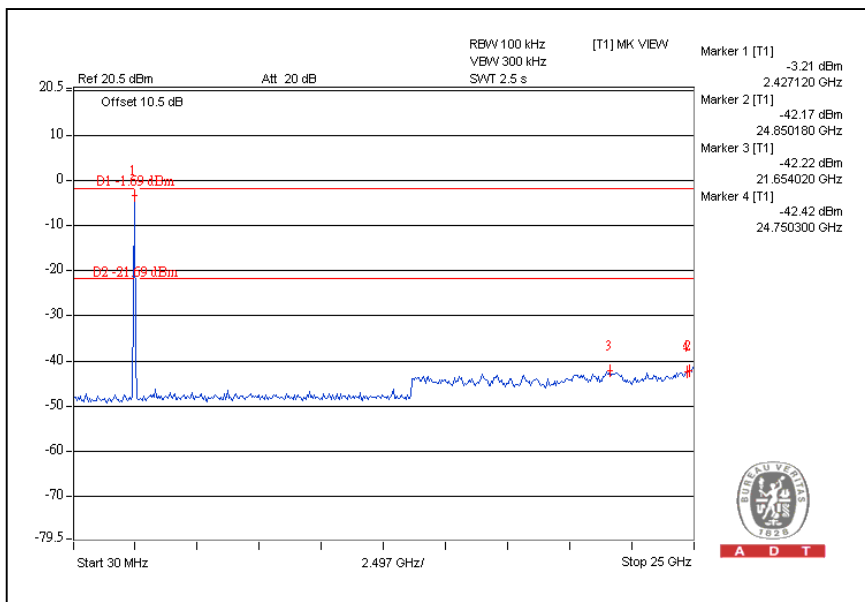
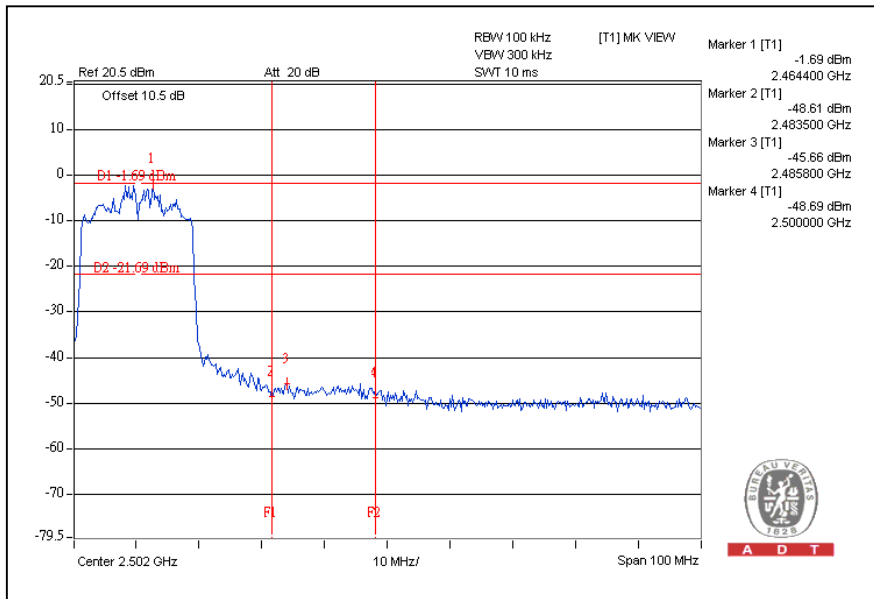



A D T

# For Chain(1) CH1

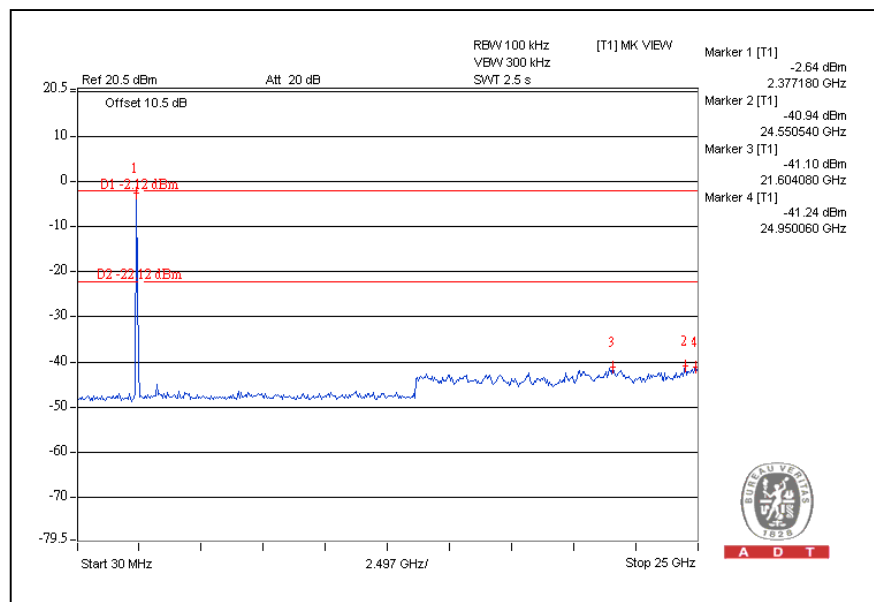
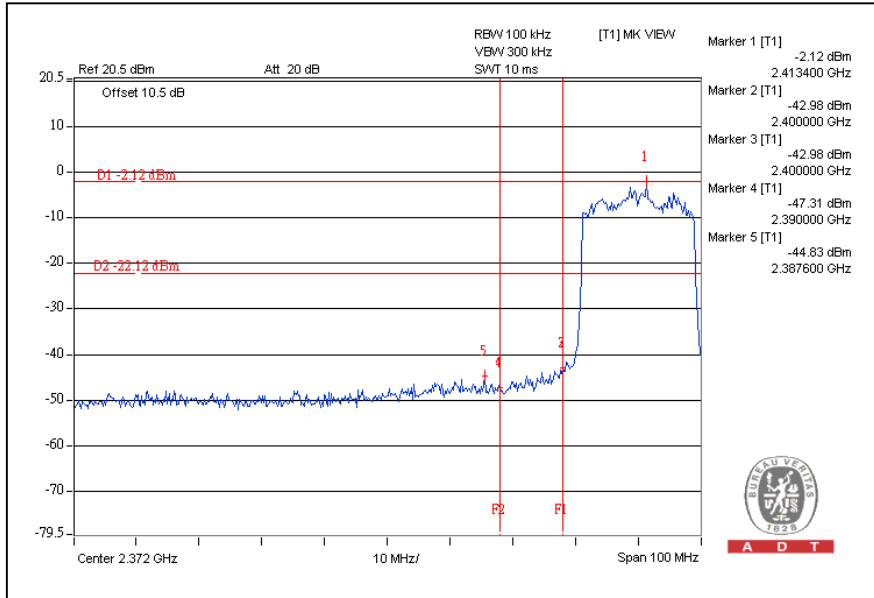



A D T

# CH11

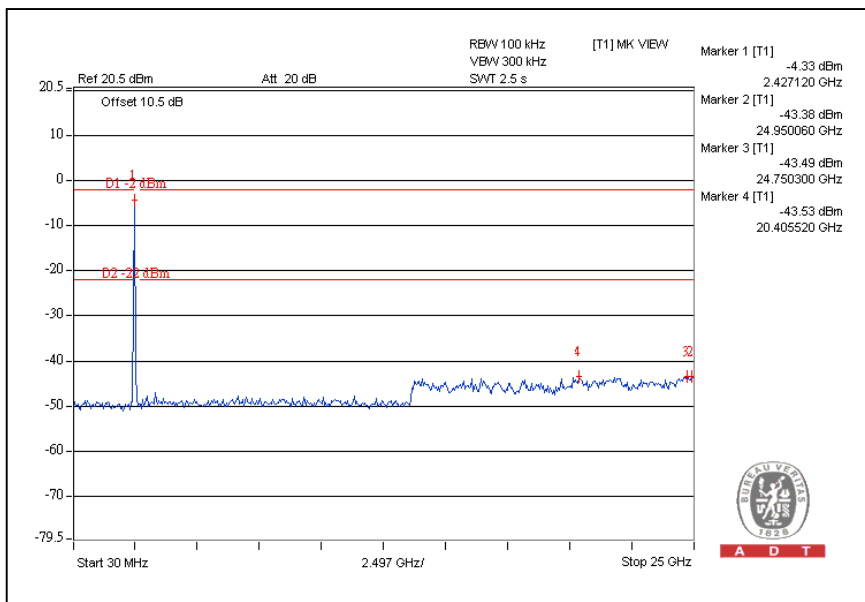
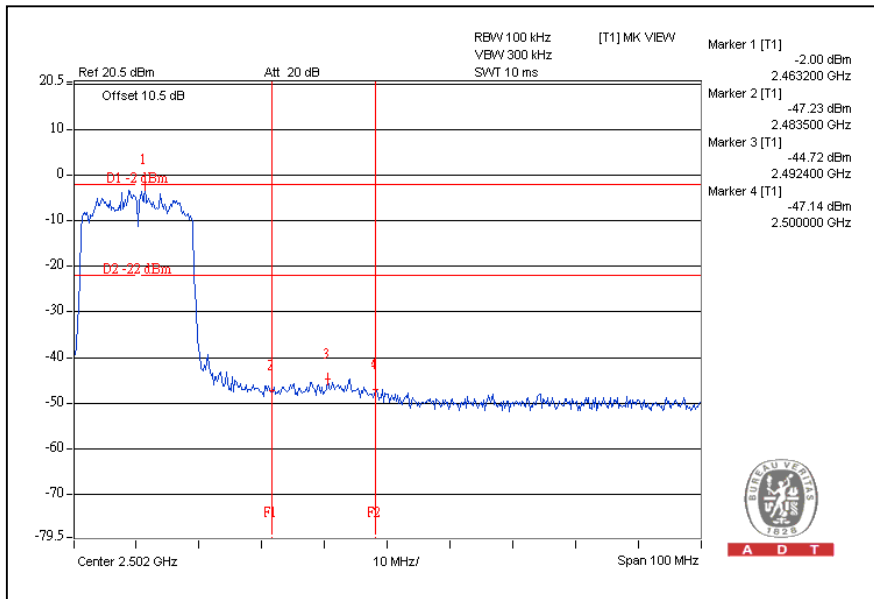



A D T

### 802.11n (40MHz) OFDM MODULATION:

For Chain(0)

CH3

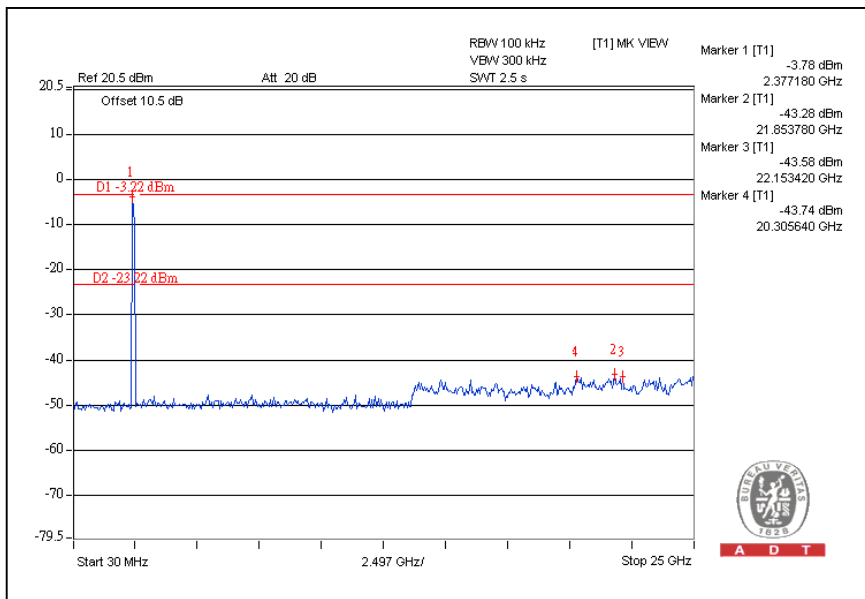
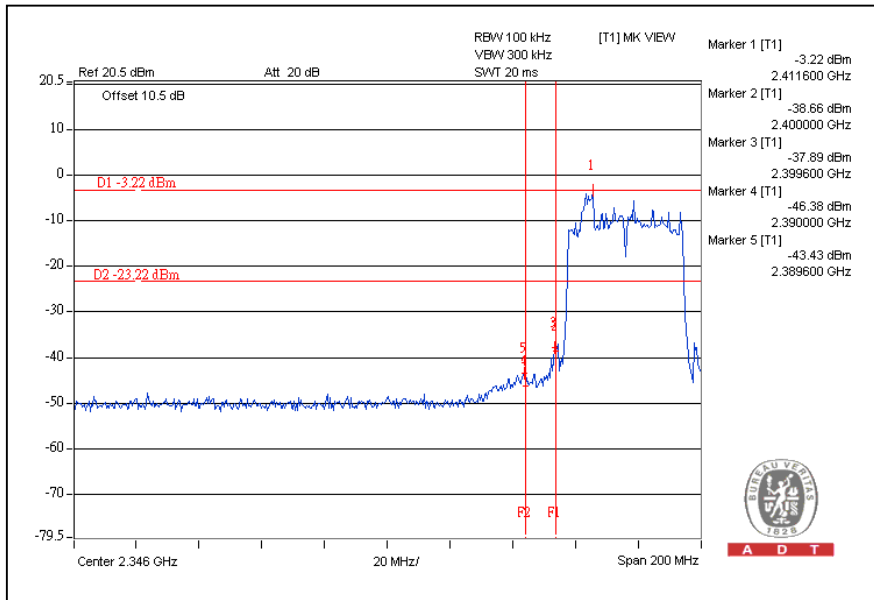



A D T

# CH9

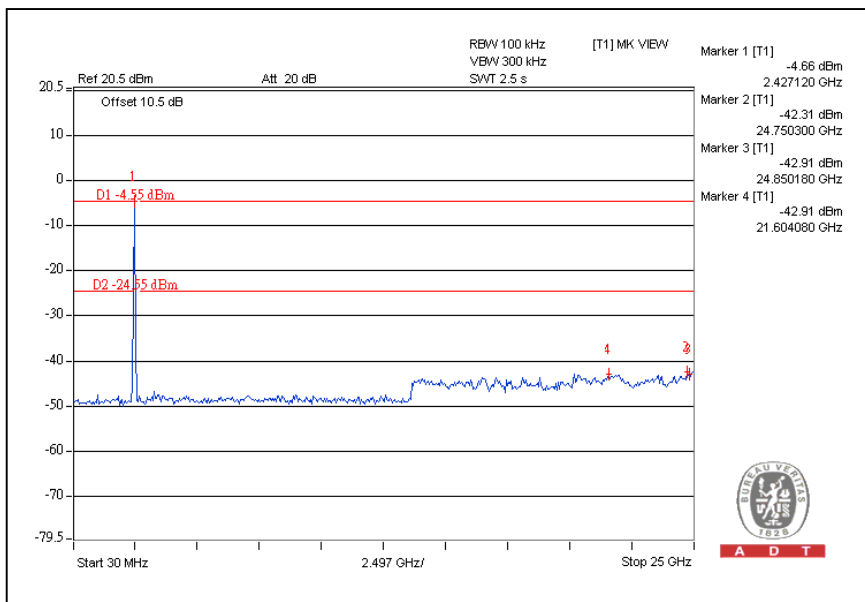
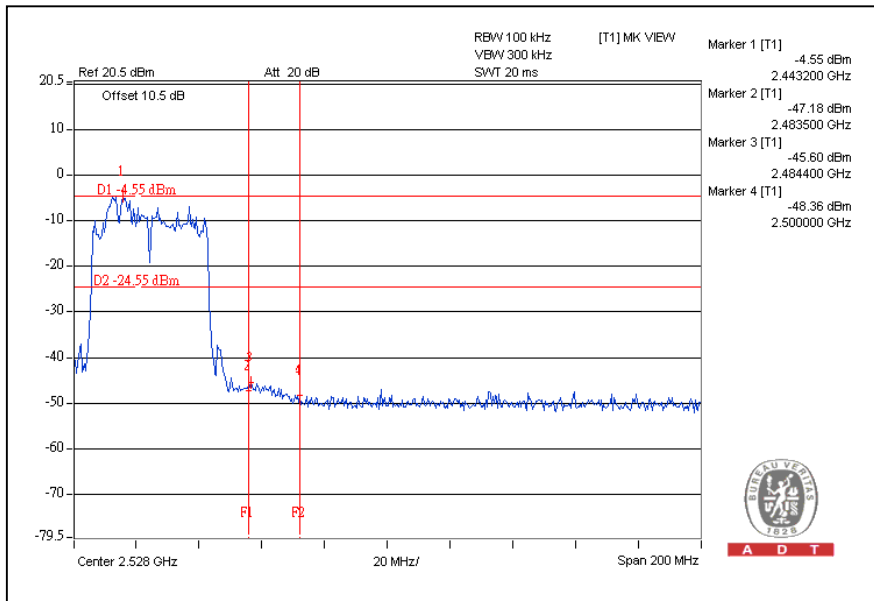



A D T

# For Chain(1) CH3

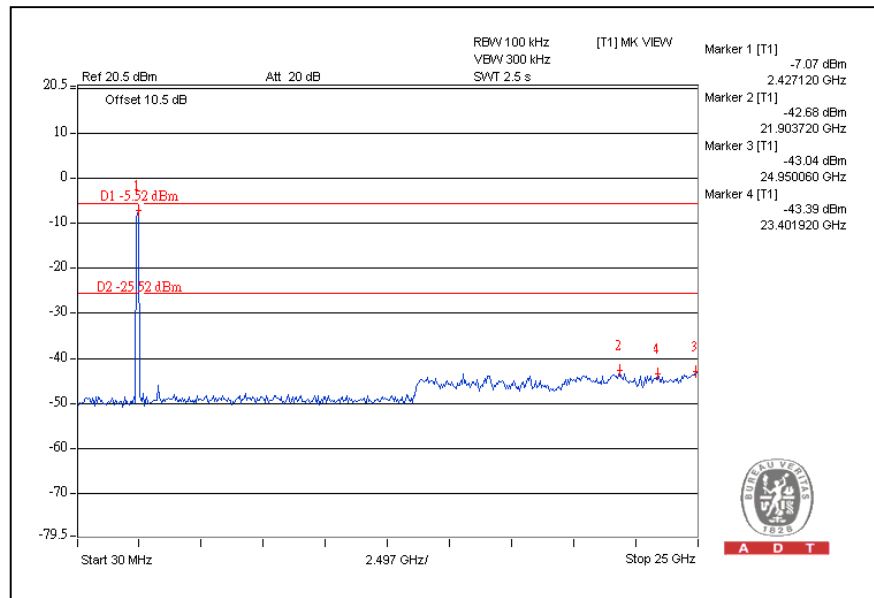
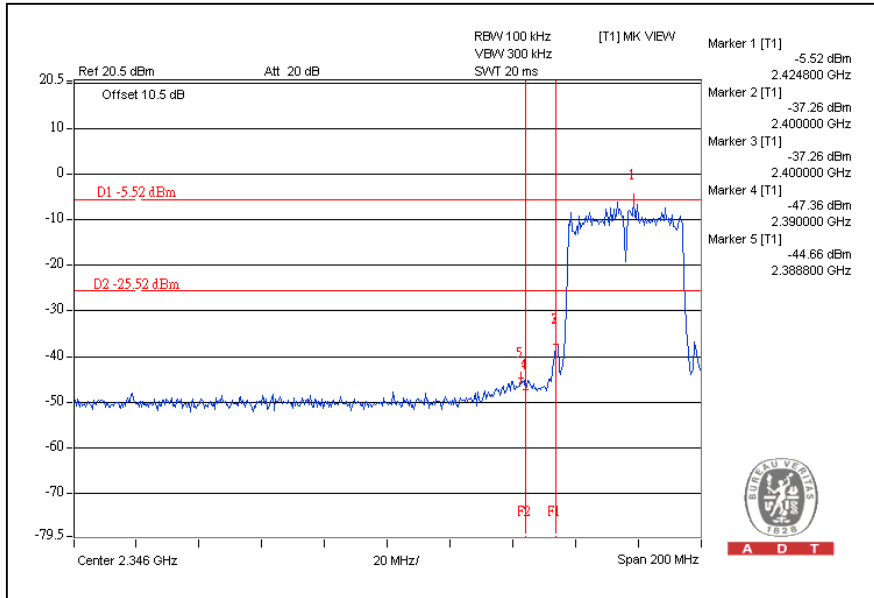





A D T

# CH9

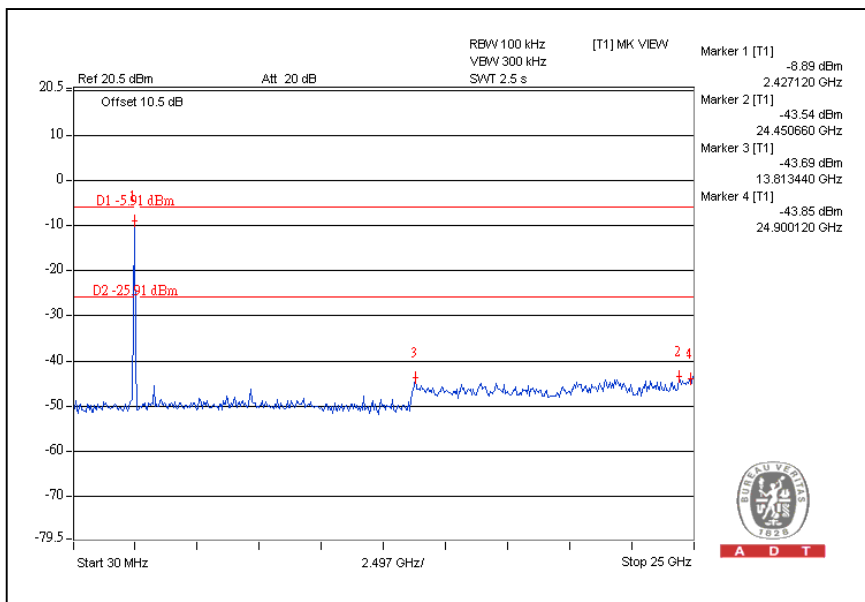
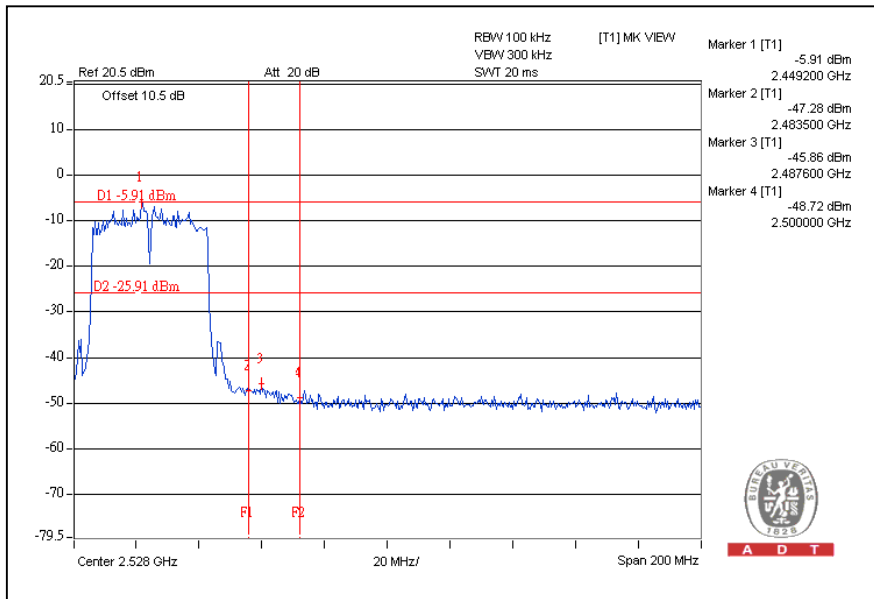



## 5. INFORMATION ON THE TESTING LABORATORIES

We, Bureau Veritas Consumer Products Services (H.K.) Ltd., Taoyuan Branch, were founded in 1988 to provide our best service in EMC, Radio, Telecom and Safety consultation. Our laboratories are accredited and approved according to ISO/IEC 17025:

Copies of accreditation certificates of our laboratories obtained from approval agencies can be downloaded from our web site: [www.adt.com.tw/index.5.phtml](http://www.adt.com.tw/index.5.phtml).

If you have any comments, please feel free to contact us at the following:

**Linko EMC/RF Lab:**

Tel: 886-2-26052180

Fax: 886-2-26052943

**Hsin Chu EMC/RF Lab:**

Tel: 886-3-5935343

Fax: 886-3-5935342

**Hwa Ya EMC/RF/Safety/Telecom Lab:**

Tel: 886-3-3183232

Fax: 886-3-3185050

**Email:** [service.adt@tw.bureauveritas.com](mailto:service.adt@tw.bureauveritas.com)

**Web Site:** [www.adt.com.tw](http://www.adt.com.tw)

The address and road map of all our labs can be found in our web site also.



A D T

## **6.APPENDIX A - MODIFICATIONS RECORDERS FOR ENGINEERING CHANGES TO THE EUT BY THE LAB**

No any modifications are made to the EUT by the lab during the test.

--- END ---