



FCC TEST REPORT

REPORT NO.: RF991228E08

MODEL NO.: X2000

FCC ID: Q87-X2000

RECEIVED: Dec. 27, 2010

TESTED: Jan. 21 to Feb. 28, 2011

ISSUED: Mar. 02, 2011

APPLICANT: Cisco Consumer Products LLC

ADDRESS: 121 Theory Drive, Irvine, CA 92617, USA

ISSUED BY: Bureau Veritas Consumer Products Services
(H.K.) Ltd., Taoyuan Branch Hsin Chu Laboratory

LAB ADDRESS : No. 81-1, Lu Liao Keng, 9th Ling,Wu Lung Tsuen,
Chiung Lin Hsiang, Hsin Chu Hsien 307, Taiwan

TEST LOCATION (1): No. 81-1, Lu Liao Keng, 9th Ling,Wu Lung Tsuen,
Chiung Lin Hsiang, Hsin Chu Hsien 307, Taiwan

TEST LOCATION (2): No. 49, Ln. 206, Wende Rd., Shangshan Tsuen,
Chiung Lin Hsiang, Hsin Chu Hsien 307, Taiwan

This test report consists of 85 pages in total. It may be duplicated completely for legal use with the approval of the applicant. It should not be reproduced except in full, without the written approval of our laboratory. The client should not use it to claim product certification, approval, or endorsement by TAF or any government agencies. The test results in the report only apply to the tested sample.





A D T

Table of Contents

RELEASE CONTROL RECORD	4
1. CERTIFICATION	5
2. SUMMARY OF TEST RESULTS	6
2.1 MEASUREMENT UNCERTAINTY	7
3. GENERAL INFORMATION	8
3.1 GENERAL DESCRIPTION OF EUT	8
3.2 DESCRIPTION OF TEST MODES	11
3.2.1 TEST MODE APPLICABILITY AND TESTED CHANNEL DETAIL	12
3.3 GENERAL DESCRIPTION OF APPLIED STANDARDS	15
3.4 DESCRIPTION OF SUPPORT UNITS.....	16
3.5 CONFIGURATION OF SYSTEM UNDER TEST	17
4. TEST TYPES AND RESULTS	18
4.1 CONDUCTED EMISSION MEASUREMENT	18
4.1.1 LIMITS OF CONDUCTED EMISSION MEASUREMENT	18
4.1.2 TEST INSTRUMENTS.....	18
4.1.3 TEST PROCEDURES	19
4.1.4 DEVIATION FROM TEST STANDARD	19
4.1.5 TEST SETUP	20
4.1.6 EUT OPERATING CONDITIONS	20
4.1.7 TEST RESULTS (With adapter 1).....	21
4.1.8 TEST RESULTS (With adapter 2).....	23
4.1.9 TEST RESULTS (With adapter 3).....	25
4.2 RADIATED EMISSION MEASUREMENT	27
4.2.1 LIMITS OF RADIATED EMISSION MEASUREMENT.....	27
4.2.2 TEST INSTRUMENTS.....	28
4.2.3 TEST PROCEDURES	30
4.2.4 DEVIATION FROM TEST STANDARD	30
4.2.5 TEST SETUP	31
4.2.6 EUT OPERATING CONDITIONS	32
4.2.7 TEST RESULTS	33
4.3 6dB BANDWIDTH MEASUREMENT	62
4.3.1 LIMITS OF 6dB BANDWIDTH MEASUREMENT	62
4.3.2 TEST INSTRUMENTS.....	62
4.3.3 TEST PROCEDURE.....	62
4.3.4 DEVIATION FROM TEST STANDARD	62
4.3.5 TEST SETUP	62
4.3.6 EUT OPERATING CONDITIONS	62
4.3.7 TEST RESULTS	63
4.4 MAXIMUM PEAK OUTPUT POWER.....	67
4.4.1 LIMITS OF MAXIMUM PEAK OUTPUT POWER MEASUREMENT	67



A D T

4.4.2	INSTRUMENTS.....	67
4.4.3	TEST PROCEDURES	67
4.4.4	DEVIATION FROM TEST STANDARD	67
4.4.5	TEST SETUP	67
4.4.6	EUT OPERATING CONDITIONS	67
4.4.7	TEST RESULTS	68
4.5	POWER SPECTRAL DENSITY MEASUREMENT	70
4.5.1	LIMITS OF POWER SPECTRAL DENSITY MEASUREMENT	70
4.5.2	TEST INSTRUMENTS.....	70
4.5.3	TEST PROCEDURE.....	70
4.5.4	DEVIATION FROM TEST STANDARD	70
4.5.5	TEST SETUP	70
4.5.6	EUT OPERATING CONDITION	70
4.5.7	TEST RESULTS	71
4.6	CONDUCTED OUT-BAND EMISSION MEASUREMENT	75
4.6.1	LIMITS OF CONDUCTED OUT-BAND EMISSION MEASUREMENT	75
4.6.2	TEST INSTRUMENTS.....	75
4.6.3	TEST PROCEDURE.....	75
4.6.4	DEVIATION FROM TEST STANDARD	75
4.6.5	EUT OPERATING CONDITION	75
4.6.6	TEST RESULTS	75
5.	INFORMATION ON THE TESTING LABORATORIES	84
6.	APPENDIX A - MODIFICATIONS RECORDERS FOR ENGINEERING CHANGES TO THE EUT BY THE LAB.....	85



A D T

RELEASE CONTROL RECORD

ISSUE NO.	REASON FOR CHANGE	DATE ISSUED
Original release	NA	Mar. 02, 2011



A D T

1. CERTIFICATION

PRODUCT: Wireless ADSL2+ Modem Router
BRAND NAME: Cisco
MODEL NO.: X2000
TEST SAMPLE: R&D SAMPLE
APPLICANT: Cisco Consumer Products LLC
TESTED: Jan. 21 to Feb. 28, 2011
STANDARDS: FCC Part 15, Subpart C (Section 15.247)
ANSI C63.4-2003
ANSI C63.10-2009

The above equipment (Model: X2000) has been tested by **Bureau Veritas Consumer Products Services (H.K.) Ltd., Taoyuan Branch**, and found compliance with the requirement of the above standards. The test record, data evaluation & Equipment Under Test (EUT) configurations represented herein are true and accurate accounts of the measurements of the sample's EMC characteristics under the conditions specified in this report.

PREPARED BY : Midoli Peng , **DATE:** Mar. 02, 2011
(Midoli Peng, Specialist)

APPROVED BY : May Chen , **DATE:** Mar. 02, 2011
(May Chen, Deputy Manager)

2. SUMMARY OF TEST RESULTS

The EUT has been tested according to the following specifications:

APPLIED STANDARD: FCC Part 15, Subpart C			
Standard Section	Test Type and Limit	Result	Remark
15.207	AC Power Conducted Emission	PASS	Meet the requirement of limit. Minimum passing margin is -1.69dB at 0.170MHz
15.247(a)(2)	Spectrum Bandwidth of a Direct Sequence Spread Spectrum System Limit: min. 500kHz	PASS	Meet the requirement of limit.
15.247(b)	Maximum Peak Output Power Limit: max. 30dBm	PASS	Meet the requirement of limit.
15.247(d)	Radiated Emissions Limit: Table 15.209	PASS	Meet the requirement of limit. Minimum passing margin is -0.5dB at 2390.00MHz
15.247(e)	Power Spectral Density Limit: max. 8dBm	PASS	Meet the requirement of limit.
15.247(d)	Conducted Out-Band Emission Measurement Limit: 20dB less than the peak value of fundamental frequency	PASS	Meet the requirement of limit.
15.203	Antenna Requirement	PASS	No antenna connector is used.



A D T

2.1 MEASUREMENT UNCERTAINTY

Where relevant, the following measurement uncertainty levels have been estimated for tests performed on the EUT as specified in CISPR 16-4-2:

This uncertainty represents an expanded uncertainty expressed at approximately the 95% confidence level using a coverage factor of $k=2$.

Measurement	Value
Conducted emissions	2.45 dB
Radiated emissions (30MHz-1GHz)	3.94 dB
Radiated emissions (1GHz -18GHz)	2.19 dB
Radiated emissions (18GHz -40GHz)	2.55 dB



A D T

3. GENERAL INFORMATION

3.1 GENERAL DESCRIPTION OF EUT

PRODUCT	Wireless ADSL2+ Modem Router
MODEL NO.	X2000
FCC ID	Q87-X2000
POWER SUPPLY	DC 12V from power adapter
MODULATION TYPE	CCK, DQPSK, DBPSK for DSSS 64QAM, 16QAM, QPSK, BPSK for OFDM
MODULATION TECHNOLOGY	DSSS, OFDM
TRANSFER RATE	802.11b :11/5.5/2/1Mbps 802.11g : 54/48/36/24/18/12/9/6Mbps 802.11n (20MHz, 400ns GI): 144.4 / 130 / 115.6 / 86.7 / 72.2 / 65 / 57.8 / 43.3 / 28.9 / 21.7 / 14.4 / 7.2Mbps 802.11n (40MHz, 400ns GI): 300 / 270 / 240 / 180 / 150 / 135 / 120 / 90 / 60 / 45 / 30 / 15Mbps
OPERATING FREQUENCY	2.412 ~ 2.462GHz
NUMBER OF CHANNEL	11 for 802.11b, 802.11g, 802.11n (20MHz) 7 for 802.11n (40MHz)
MAXIMUM OUTPUT POWER	802.11b: 166.0mW 802.11g: 371.5mW 802.11n (20MHz): 618.1mW 802.11n (40MHz): 292.9mW
ANTENNA TYPE	Please see note 1
DATA CABLE	NA
I/O PORTS	ADSL port x 1 WAN port x 1 LAN port (10, 100Mbps) x 3
ASSOCIATED DEVICES	Adapter x 1

NOTE:

1. There are two antennas provided to this EUT, please refer to the following table:

Transmitter Circuit	Antenna Type	Connecter	Gain (dBi) <Include cable loss>	Cable Length (mm)
Chain (0) / Left	PIFA	NA	1.45	75
Chain (1) / Right	PIFA	NA	3.04	188

2. The EUT must be supplied with a power adapter and following three different model names could be chosen:

Adapter	Brand	Model No.	Spec.
Adapter 1	Bestec	EA0121WVA D	Input: 100-240V, 0.5A, 50-60Hz Output: DC12V, 1A DC output cable (unshielded, 1.6m)
Adapter 2	LEI	MU12-N120100-A1	Input: 100-240V, 0.5A, 50-60Hz Output: DC12V, 1A DC output cable (unshielded, 1.6m)
Adapter 3	Bestec	BT-AE120ADE	Input: 100-240V, 0.5A, 50-60Hz AC input cable(unshielded, 1.9m) Output: DC12V, 1A DC output cable (unshielded, 1.6m)

For radiated test, the EUT was pre-tested with above adapters, the worse case was found in adapter 3. Therefore only the test data of the adapter was recorded in this report.

3. The EUT was pre-tested under the following modes:

Test Mode	Description
Mode A	Level-set (Put on tabletop)
Mode B	Tower-set (Wall-mounted)

From the above modes, the worst case was found in **Mode A**. Therefore only the test data of the modes were recorded in this report.

4. The EUT incorporates a MIMO function with 802.11n.
5. The EUT is 2 * 2 spatial MIMO (2Tx & 2Rx) without beam forming function. The 11b/g legacy mode is limited to single transmitter only.
6. When the EUT operating in 802.11n, the software operation, which is defined by manufacturer, MCS (Modulation and Coding Schemes) from 0 to 15.



A D T

7. The EUT complies with 802.11n standards and backwards compatible with 802.11b, 802.11g products.
8. The above EUT information was declared by the manufacturer and for more detailed features description, please refer to the manufacturer's specifications or User's Manual.

3.2 DESCRIPTION OF TEST MODES

Eleven channels are provided for 802.11b, 802.11g, 802.11n (20MHz):

CHANNEL	FREQUENCY	CHANNEL	FREQUENCY
1	2412MHz	7	2442MHz
2	2417MHz	8	2447MHz
3	2422MHz	9	2452MHz
4	2427MHz	10	2457MHz
5	2432MHz	11	2462MHz
6	2437MHz		

Seven channels are provided for 802.11n (40MHz):

CHANNEL	FREQUENCY	CHANNEL	FREQUENCY
3	2422MHz	7	2442MHz
4	2427MHz	8	2447MHz
5	2432MHz	9	2452MHz
6	2437MHz		



A D T

3.2.1 TEST MODE APPLICABILITY AND TESTED CHANNEL DETAIL

EUT CONFIGURE MODE	APPLICABLE TO				DESCRIPTION
	PLC	RE < 1G	RE ≥ 1G	APCM	
1	√	-	-	-	With Adapter 1
2	√	-	-	-	With Adapter 2
3	√	√	√	√	With Adapter 3

Where **PLC**: Power Line Conducted Emission **RE < 1G**: Radiated Emission below 1GHz
RE ≥ 1G: Radiated Emission above 1GHz **APCM**: Antenna Port Conducted Measurement

ANTENNA COMBINATION MODE:

COMBINATION MODE	OPERATION MODE	CHAIN(0) (TX)	CHAIN(1) (TX)
A	802.11 b	√	
B	802.11 b		√
C	802.11 g	√	
D	802.11 g		√
E	802.11n(20MHz) for MCS0~7	√	
F	802.11n(20MHz) for MCS0~7		√
G	802.11n(20MHz) for MCS8~15	√	√
H	802.11n(40MHz) for MCS0~7	√	
I	802.11n(40MHz) for MCS0~7		√
J	802.11n(40MHz) for MCS8~15	√	√

Note:

1. The above information was declared by manufacturer and for more detailed features description, please refer to the manufacturer's specifications or user's manual.
2. Mode B, D, G & J the worst modes, was selected as representative mode for the report.

POWER LINE CONDUCTED EMISSION TEST:

- Pre-Scan has been conducted to determine the worst-case mode from all possible combinations between available modulations, data rates and antenna ports (if EUT with antenna diversity architecture).
- Following channel(s) was (were) selected for the final test as listed below.

MODE	AVAILABLE CHANNEL	TESTED CHANNEL	MODULATION TECHNOLOGY	MODULATION TYPE	DATA RATE (Mbps)	COMBINATION MODE
802.11n (20MHz)	1 to 11	6	OFDM	BPSK	14.4	G



A D T

RADIATED EMISSION TEST (BELOW 1 GHz):

- Pre-Scan has been conducted to determine the worst-case mode from all possible combinations between available modulations, data rates and antenna ports (if EUT with antenna diversity architecture).
- Following channel(s) was (were) selected for the final test as listed below.

MODE	AVAILABLE CHANNEL	TESTED CHANNEL	MODULATION TECHNOLOGY	MODULATION TYPE	DATA RATE (Mbps)	COMBINATION MODE
802.11n (20MHz)	1 to 11	6	OFDM	BPSK	14.4	G

RADIATED EMISSION TEST (ABOVE 1 GHz):

- Pre-Scan has been conducted to determine the worst-case mode from all possible combinations between available modulations, data rates and antenna ports (if EUT with antenna diversity architecture).
- Following channel(s) was (were) selected for the final test as listed below.

MODE	AVAILABLE CHANNEL	TESTED CHANNEL	MODULATION TECHNOLOGY	MODULATION TYPE	DATA RATE (Mbps)	COMBINATION MODE
802.11b	1 to 11	1, 6, 11	DSSS	DBPSK	1	B
802.11g	1 to 11	1, 6, 11	OFDM	BPSK	6	D
802.11n (20MHz)	1 to 11	1, 6, 11	OFDM	BPSK	14.4	G
802.11n (40MHz)	3 to 9	3, 6, 9	OFDM	BPSK	30	J

CONDUCTED OUT-BAND EMISSION MEASUREMENT:

- Pre-Scan has been conducted to determine the worst-case mode from all possible combinations between available modulations, data rates and antenna ports (if EUT with antenna diversity architecture).
- Following channel(s) was (were) selected for the final test as listed below.

MODE	AVAILABLE CHANNEL	TESTED CHANNEL	MODULATION TECHNOLOGY	MODULATION TYPE	DATA RATE (Mbps)	COMBINATION MODE
802.11b	1 to 11	1, 11	DSSS	DBPSK	1	B
802.11g	1 to 11	1, 11	OFDM	BPSK	6	D
For 2.4 GHz	1 to 11	1, 11	OFDM	BPSK	14.4	G
For 2.4 GHz	3 to 9	3, 9	OFDM	BPSK	30	J

✧ After verification, conducted out band emission as show worst chain in report by investigations.

ANTENNA PORT CONDUCTED MEASUREMENT:

- This item includes all test value of each mode, but only includes spectrum plot of worst value of each mode.
- Pre-Scan has been conducted to determine the worst-case mode from all possible combinations between available modulations, data rates and antenna ports (if EUT with antenna diversity architecture).
- Following channel(s) was (were) selected for the final test as listed below.

MODE	AVAILABLE CHANNEL	TESTED CHANNEL	MODULATION TECHNOLOGY	MODULATION TYPE	DATA RATE (Mbps)	COMBINATION MODE
802.11b	1 to 11	1, 6, 11	DSSS	DBPSK	1	B
802.11g	1 to 11	1, 6, 11	OFDM	BPSK	6	D
802.11n (20MHz)	1 to 11	1, 6, 11	OFDM	BPSK	14.4	G
802.11n (40MHz)	3 to 9	3, 6, 9	OFDM	BPSK	30	J

※ After verification, bandwidth as show worst chain in report by investigations.

※ **TEST CONDITION:**

APPLICABLE TO	ENVIRONMENTAL CONDITIONS	INPUT POWER	TESTED BY
RE ³ 1G	16deg. C, 67%RH, 1025 hPa	120Vac, 60Hz	Rex Huang
RE<1G	20deg. C, 70%RH, 1025 hPa	120Vac, 60Hz	Rex Huang
PLC	21deg. C, 59%RH, 1025 hPa	120Vac, 60Hz	Scott Chen
APCM	25deg. C, 60%RH, 1025 hPa	120Vac, 60Hz	Rex Huang

3.3 GENERAL DESCRIPTION OF APPLIED STANDARDS

The EUT is a RF product. According to the specifications of the manufacturer, it must comply with the requirements of the following standards:

FCC Part 15, Subpart C. (15.247)

ANSI C63.4-2003

ANSI C63.10-2009

All test items have been performed and recorded as per the above standards.

NOTE: The EUT has been verified to comply with the requirements of FCC Part 15, Subpart B, Class B (DoC). The test report has been issued separately.



A D T

3.4 DESCRIPTION OF SUPPORT UNITS

The EUT has been tested as an independent unit together with other necessary accessories or support units. The following support units or accessories were used to form a representative test configuration during the tests.

No.	Product	Brand	Model No.	Serial No.	FCC ID
1	NOTEBOOK COMPUTER	DELL	PP32LA	FSLB32S	FCC DoC
2	NOTEBOOK COMPUTER	DELL	PP32LA	GSLB32S	FCC DoC
3	CO-ROUTER	ZyXEL	IES-1000	S4Z3112558	NA
4	HUB	ZyXEL	ES-116P	S060H02000215	FCC DoC

No.	Signal cable description
1	RJ-45 cable unshielded, 10m
2	RJ-45 cable unshielded, 10m
3	RJ-11 cable shielded, 10m
4	RJ-45 cable unshielded, 10m

Note: The power cords of the above support units were unshielded (1.8m).

3.5 CONFIGURATION OF SYSTEM UNDER TEST

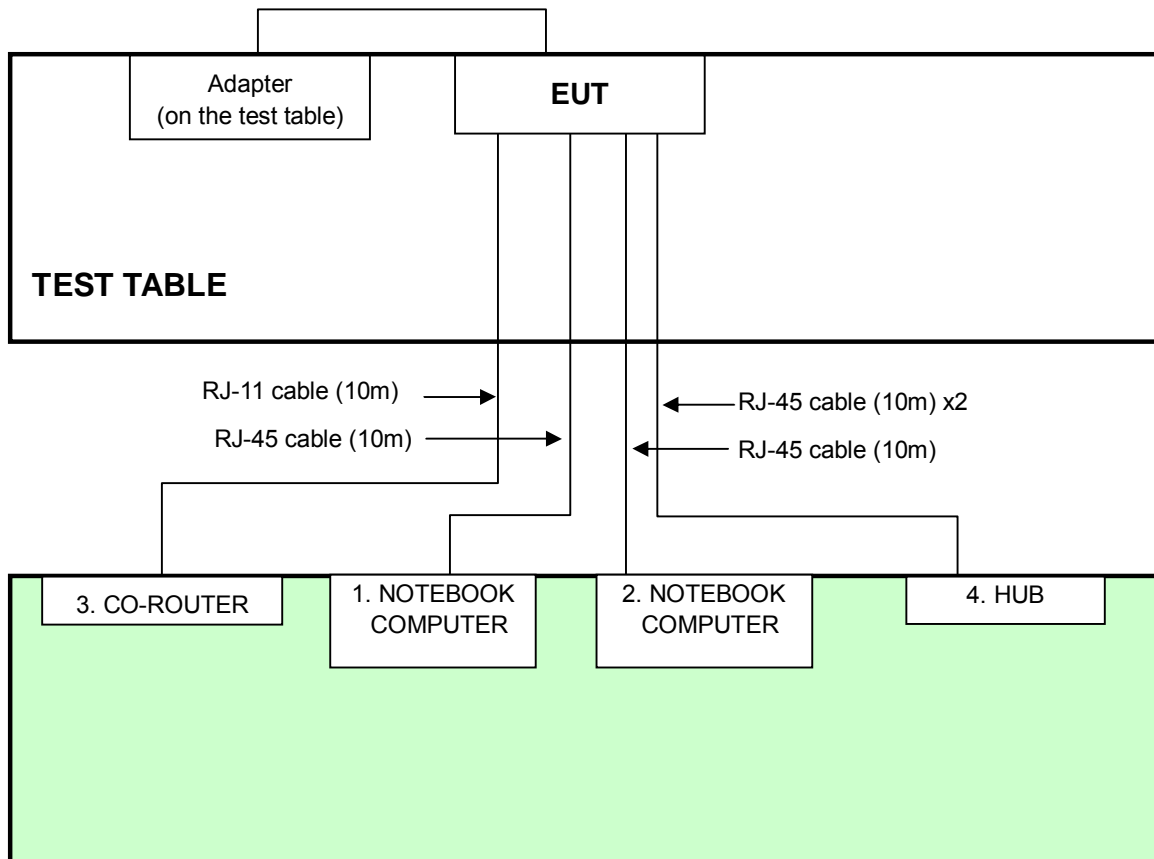

4. TEST TYPES AND RESULTS

4.1 CONDUCTED EMISSION MEASUREMENT

4.1.1 LIMITS OF CONDUCTED EMISSION MEASUREMENT

FREQUENCY OF EMISSION (MHz)	CONDUCTED LIMIT (dB μ V)	
0.15-0.5 0.5-5 5-30	Quasi-peak	Average
	66 to 56	56 to 46
	56	46
	60	50

- NOTE:**
1. The lower limit shall apply at the transition frequencies.
 2. The limit decreases in line with the logarithm of the frequency in the range of 0.15 to 0.50 MHz.
 3. All emanations from a class A/B digital device or system, including any network of conductors and apparatus connected thereto, shall not exceed the level of field strengths specified above.

4.1.2 TEST INSTRUMENTS

DESCRIPTION & MANUFACTURER	MODEL NO.	SERIAL NO.	CALIBRATED DATE	CALIBRATED UNTIL
ROHDE & SCHWARZ Test Receiver	ESCS 30	100287	Mar. 01, 2010	Feb. 28, 2011
Line-Impedance Stabilization Network (for EUT)	NSLK 8127	8127-523	Sep. 17, 2010	Sep. 16, 2011
Line-Impedance Stabilization Network (for Peripheral)	ENV-216	100072	June 11, 2010	June 10, 2011
RF Cable (JYEBAO)	5DFB	CONCAB-003	Aug. 06, 2010	Aug. 05, 2011
50 ohms Terminator	50	3	Nov. 03, 2010	Nov. 02, 2011
Software	BV ADT_Cond_V7.3.7	NA	NA	NA

Note:

1. The calibration interval of the above test instruments is 12 months and the calibrations are traceable to NML/ROC and NIST/USA.
2. The test was performed in Shielded Room No. A.
3. The VCCI Con A Registration No. is C-817.

4.1.3 TEST PROCEDURES

- a. The EUT was placed 0.4 meters from the conducting wall of the shielded room with EUT being connected to the power mains through a line impedance stabilization network (LISN). Other support units were connected to the power mains through another LISN. The two LISNs provide 50 ohm/ 50uH of coupling impedance for the measuring instrument.
- b. Both lines of the power mains connected to the EUT were checked for maximum conducted interference.
- c. The frequency range from 150kHz to 30MHz was searched. Emission levels under (Limit - 20dB) were not recorded.

4.1.4 DEVIATION FROM TEST STANDARD

No deviation

4.1.5 TEST SETUP

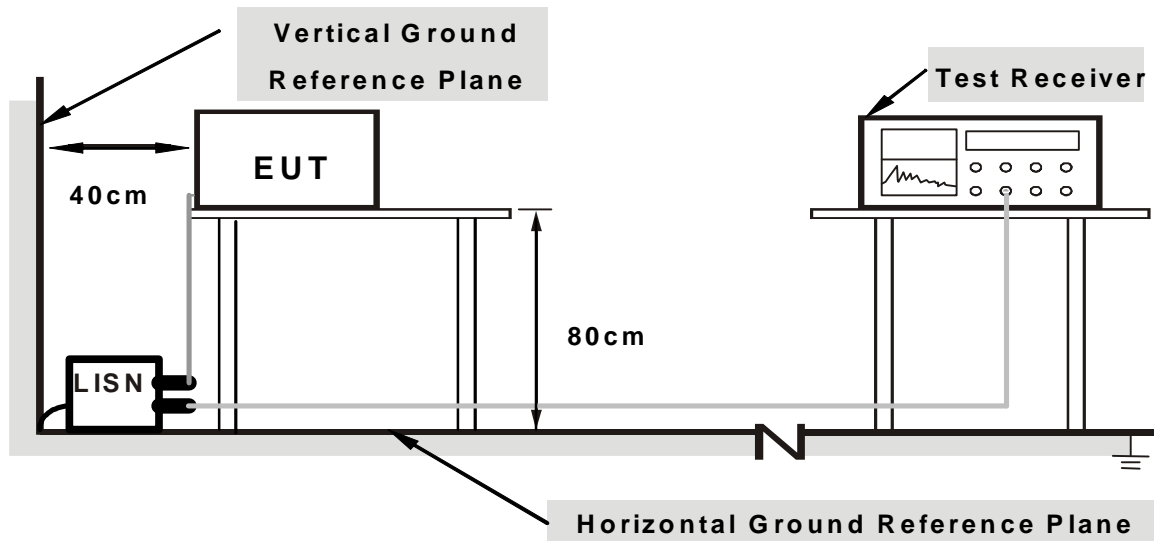

Note: 1.Support units were connected to second LISN.

2.Both of LISNs (AMN) are 80 cm from EUT and at least 80 from other units and other metal planes

For the actual test configuration, please refer to the related item – Photographs of the Test Configuration.

4.1.6 EUT OPERATING CONDITIONS

1. Placed the EUT on testing table.
2. Prepared other computer systems (support units 1~3) to act as communication partners and placed them outside of testing area.
3. The communication partners ran test program “BCM43225 Broadcom comand list.txt” to enable EUT under transmission/receiving condition continuously via RJ-45 cables and RJ-11 cable transmission.

4.1.7 TEST RESULTS (With adapter 1)

PHASE	Line (L)	6dB BANDWIDTH	9 kHz
--------------	----------	----------------------	-------

No	Freq.	Corr.	Reading Value		Emission Level		Limit		Margin	
	[MHz]	Factor	[dB (uV)]		[dB (uV)]		[dB (uV)]		(dB)	
		(dB)	Q.P.	AV.	Q.P.	AV.	Q.P.	AV.	Q.P.	AV.
1	0.181	0.36	48.34	-	48.70	-	64.43	54.43	-15.73	-
2	0.224	0.36	44.95	-	45.31	-	62.66	52.66	-17.35	-
3	0.267	0.36	44.24	-	44.60	-	61.20	51.20	-16.60	-
4	0.314	0.36	39.83	-	40.19	-	59.86	49.86	-19.67	-
5	0.638	0.38	43.36	-	43.74	-	56.00	46.00	-12.26	-
6	18.797	1.03	36.75	-	37.78	-	60.00	50.00	-22.22	-

- REMARKS:**
1. Q.P. and AV. are abbreviations of quasi-peak and average individually.
 2. "-": The Quasi-peak reading value also meets average limit and measurement with the average detector is unnecessary.
 3. The emission levels of other frequencies were very low against the limit.
 4. Margin value = Emission level - Limit value
 5. Correction factor = Insertion loss + Cable loss
 6. Emission Level = Correction Factor + Reading Value.

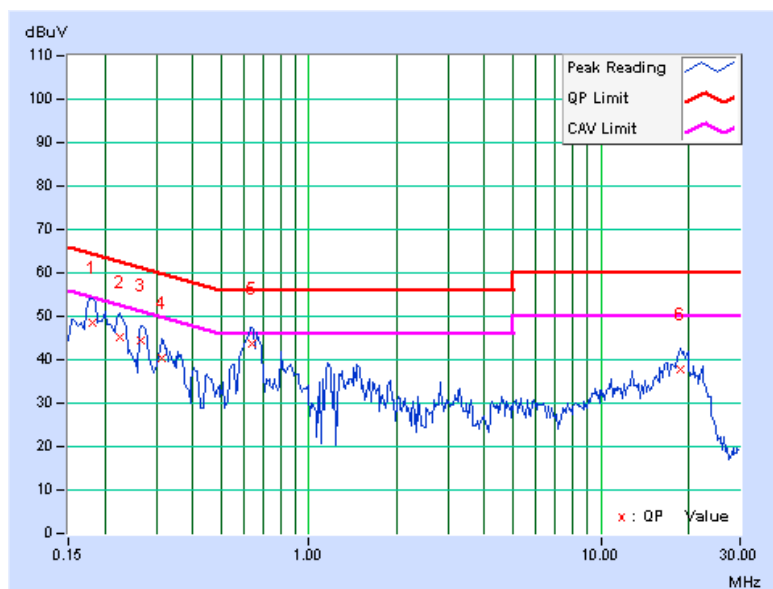

PHASE	Neutral (N)	6dB BANDWIDTH	9 kHz
--------------	-------------	----------------------	-------

No	Freq. [MHz]	Corr. Factor (dB)	Reading Value [dB (uV)]		Emission Level [dB (uV)]		Limit [dB (uV)]		Margin (dB)	
			Q.P.	AV.	Q.P.	AV.	Q.P.	AV.	Q.P.	AV.
			1	0.172	0.10	46.52	-	46.62	-	64.85
2	0.224	0.10	47.41	-	47.51	-	62.66	52.66	-15.15	-
3	0.267	0.10	45.23	-	45.33	-	61.20	51.20	-15.87	-
4	0.314	0.11	39.91	-	40.02	-	59.86	49.86	-19.85	-
5	0.638	0.13	38.82	-	38.95	-	56.00	46.00	-17.05	-
6	18.785	1.08	36.51	-	37.59	-	60.00	50.00	-22.41	-

- REMARKS:**
1. Q.P. and AV. are abbreviations of quasi-peak and average individually.
 2. "-": The Quasi-peak reading value also meets average limit and measurement with the average detector is unnecessary.
 3. The emission levels of other frequencies were very low against the limit.
 4. Margin value = Emission level - Limit value
 5. Correction factor = Insertion loss + Cable loss
 6. Emission Level = Correction Factor + Reading Value.

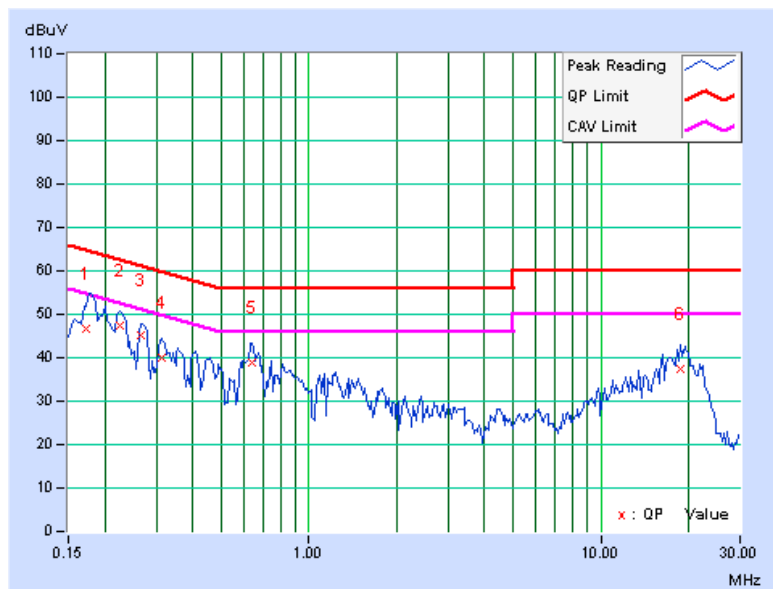

4.1.8 TEST RESULTS (With adapter 2)

PHASE	Line (L)	6dB BANDWIDTH	9 kHz
-------	----------	---------------	-------

No	Freq. [MHz]	Corr. Factor (dB)	Reading Value [dB (uV)]		Emission Level [dB (uV)]		Limit [dB (uV)]		Margin (dB)	
			Q.P.	AV.	Q.P.	AV.	Q.P.	AV.	Q.P.	AV.
			1	0.158	0.36	58.15	46.85	58.51	47.21	65.58
2	0.212	0.36	50.91	-	51.27	-	63.11	53.11	-11.84	-
3	0.248	0.36	42.98	-	43.34	-	61.84	51.84	-18.50	-
4	0.326	0.36	39.81	-	40.17	-	59.56	49.56	-19.39	-
5	0.423	0.36	34.27	-	34.63	-	57.38	47.38	-22.75	-
6	2.012	0.46	29.25	-	29.71	-	56.00	46.00	-26.29	-

- REMARKS:**
1. Q.P. and AV. are abbreviations of quasi-peak and average individually.
 2. "-": The Quasi-peak reading value also meets average limit and measurement with the average detector is unnecessary.
 3. The emission levels of other frequencies were very low against the limit.
 4. Margin value = Emission level - Limit value
 5. Correction factor = Insertion loss + Cable loss
 6. Emission Level = Correction Factor + Reading Value.

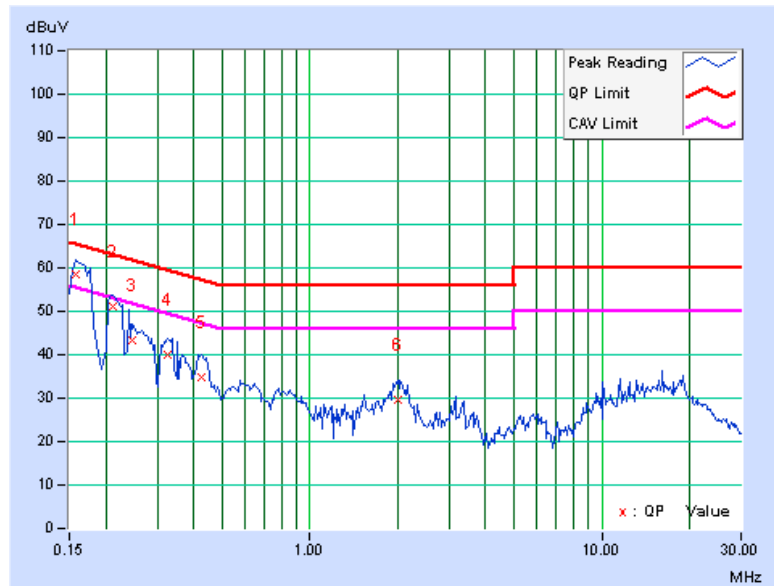

PHASE	Neutral (N)	6dB BANDWIDTH	9 kHz
--------------	-------------	----------------------	-------

No	Freq. [MHz]	Corr. Factor (dB)	Reading Value		Emission Level		Limit		Margin	
			[dB (uV)]		[dB (uV)]		[dB (uV)]		(dB)	
			Q.P.	AV.	Q.P.	AV.	Q.P.	AV.	Q.P.	AV.
1	0.154	0.10	58.55	47.76	58.65	47.86	65.79	55.79	-7.14	-7.93
2	0.212	0.10	49.84	-	49.94	-	63.12	53.12	-13.18	-
3	0.269	0.10	41.59	-	41.69	-	61.15	51.15	-19.45	-
4	0.360	0.11	38.31	-	38.42	-	58.72	48.72	-20.30	-
5	2.066	0.20	27.62	-	27.82	-	56.00	46.00	-28.18	-
6	14.148	0.86	28.04	-	28.90	-	60.00	50.00	-31.10	-

- REMARKS:**
1. Q.P. and AV. are abbreviations of quasi-peak and average individually.
 2. "-": The Quasi-peak reading value also meets average limit and measurement with the average detector is unnecessary.
 3. The emission levels of other frequencies were very low against the limit.
 4. Margin value = Emission level - Limit value
 5. Correction factor = Insertion loss + Cable loss
 6. Emission Level = Correction Factor + Reading Value.

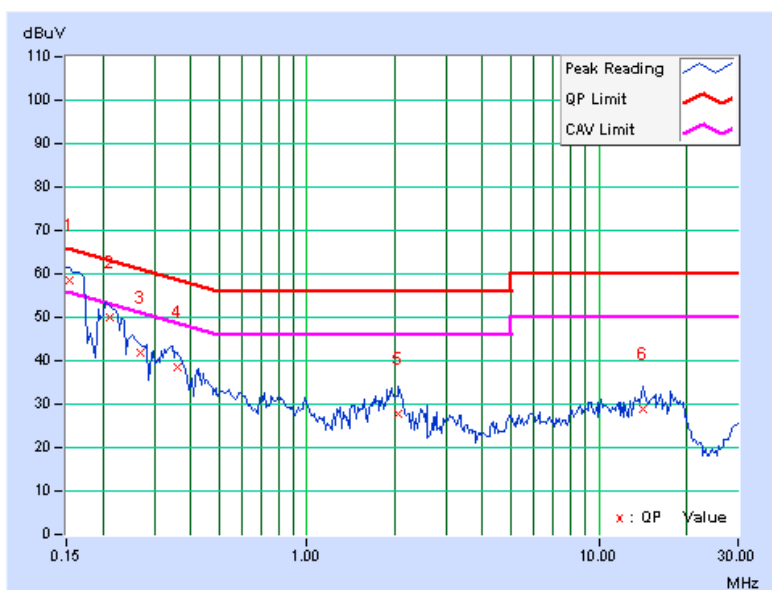

4.1.9 TEST RESULTS (With adapter 3)

PHASE	Line (L)	6dB BANDWIDTH	9 kHz
--------------	----------	----------------------	-------

No	Freq. [MHz]	Corr. Factor (dB)	Reading Value [dB (uV)]		Emission Level [dB (uV)]		Limit [dB (uV)]		Margin (dB)	
			Q.P.	AV.	Q.P.	AV.	Q.P.	AV.	Q.P.	AV.
			1	0.173	0.36	61.10	51.19	61.46	51.55	64.79
2	0.213	0.36	54.86	43.37	55.22	43.73	63.11	53.11	-7.89	-9.38
3	0.255	0.36	53.29	39.65	53.65	40.01	61.58	51.58	-7.93	-11.57
4	0.302	0.36	48.92	-	49.28	-	60.18	50.18	-10.90	-
5	0.345	0.36	45.45	-	45.81	-	59.07	49.07	-13.26	-
6	0.396	0.36	43.86	-	44.22	-	57.93	47.93	-13.71	-

- REMARKS:**
1. Q.P. and AV. are abbreviations of quasi-peak and average individually.
 2. "-": The Quasi-peak reading value also meets average limit and measurement with the average detector is unnecessary.
 3. The emission levels of other frequencies were very low against the limit.
 4. Margin value = Emission level - Limit value
 5. Correction factor = Insertion loss + Cable loss
 6. Emission Level = Correction Factor + Reading Value.

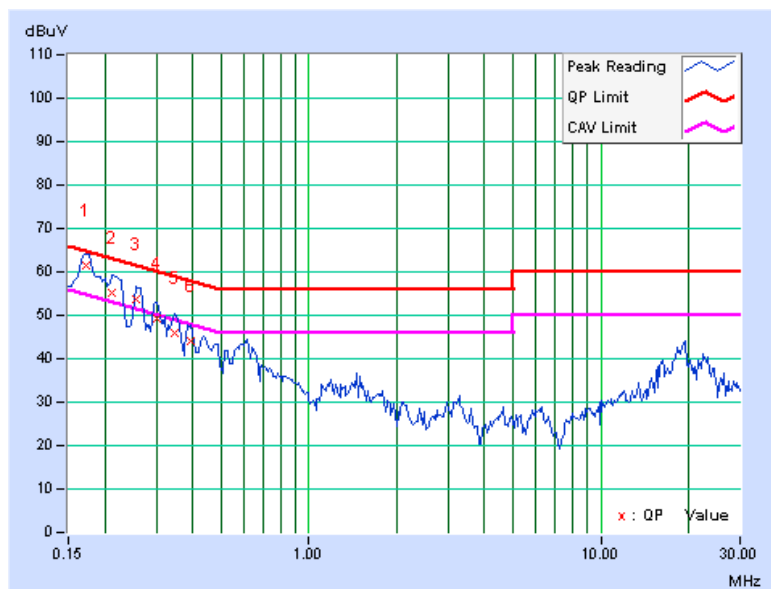

PHASE	Neutral (N)	6dB BANDWIDTH	9 kHz
-------	-------------	---------------	-------

No	Freq.	Corr.	Reading Value		Emission Level		Limit		Margin	
	[MHz]	Factor	[dB (uV)]		[dB (uV)]		[dB (uV)]		(dB)	
		(dB)	Q.P.	AV.	Q.P.	AV.	Q.P.	AV.	Q.P.	AV.
1	0.170	0.10	62.03	53.20	62.13	53.30	64.98	54.98	-2.86	-1.69
2	0.215	0.10	56.94	45.46	57.04	45.56	63.03	53.03	-5.99	-7.47
3	0.257	0.10	56.33	44.29	56.43	44.39	61.53	51.53	-5.09	-7.13
4	0.305	0.11	50.18	39.42	50.29	39.53	60.12	50.12	-9.83	-10.59
5	0.345	0.11	47.69	-	47.80	-	59.07	49.07	-11.28	-
6	0.384	0.11	45.34	-	45.45	-	58.18	48.18	-12.74	-

- REMARKS:**
1. Q.P. and AV. are abbreviations of quasi-peak and average individually.
 2. "-": The Quasi-peak reading value also meets average limit and measurement with the average detector is unnecessary.
 3. The emission levels of other frequencies were very low against the limit.
 4. Margin value = Emission level - Limit value
 5. Correction factor = Insertion loss + Cable loss
 6. Emission Level = Correction Factor + Reading Value.

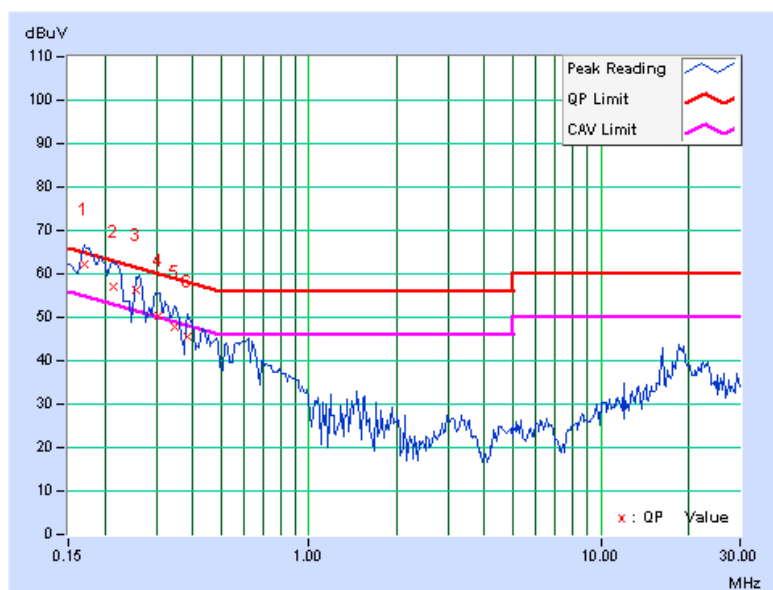

4.2 RADIATED EMISSION MEASUREMENT

4.2.1 LIMITS OF RADIATED EMISSION MEASUREMENT

Emissions radiated outside of the specified bands, shall be according to the general radiated limits in 15.209 as following:

Frequencies (MHz)	Field strength (microvolts/meter)	Measurement distance (meters)
0.009-0.490	2400/F(kHz)	300
0.490-1.705	24000/F(kHz)	30
1.705-30.0	30	30
30-88	100	3
88-216	150	3
216-960	200	3
Above 960	500	3

NOTE:

1. The lower limit shall apply at the transition frequencies.
2. Emission level (dBuV/m) = 20 log Emission level (uV/m).
3. As shown in 15.35(b), for frequencies above 1000MHz, the field strength limits are based on average detector, however, the peak field strength of any emission shall not exceed the maximum permitted average limits, specified above by more than 20dB under any condition of modulation.
4. Section 15.205 restricted bands of operation shall compliance with the limits in Section 15.209.



A D T

4.2.2 TEST INSTRUMENTS

Below 1GHz test:

DESCRIPTION & MANUFACTURER	MODEL NO.	SERIAL NO.	CALIBRATED DATE	CALIBRATED UNTIL
ROHDE & SCHWARZ Spectrum Analyzer	FSP40	100036	Dec. 08, 2010	Dec. 07, 2011
Agilent PSA Spectrum Analyzer	E4446A	MY46180622	May 12, 2010	May 11, 2011
HP Pre_Amplifier	8449B	300801923	Nov. 01, 2010	Oct. 31, 2011
ROHDE & SCHWARZ Test Receiver	ESCS30	847124/029	Sep. 03, 2010	Sep. 02, 2011
SCHWARZBECK TRILOG Broadband Antenna	VULB 9168	138	Apr. 28, 2010	Apr. 27, 2011
Schwarzbeck Horn_Antenna	BBHA9120	D124	Dec. 17, 2010	Dec. 16, 2011
Schwarzbeck Horn_Antenna	BBHA 9170	BBHA9170153	Jan. 17, 2011	Jan. 16, 2012
RF Switches	EMH-011	1001	NA	NA
RF CABLE (Chaintek)	Sucoflex 104+ Sucoflex 106	RF104-101+R F106-101	Aug. 24, 2010	Aug. 23, 2011
RF Cable	8DFB	STCCAB-30M- 1GHz	NA	NA
Software	ADT_Radiated_ V7.6.15.9.2	NA	NA	NA
CT Antenna Tower & Turn Table	NA	NA	NA	NA

Note: 1. The calibration interval of the above test instruments is 12 months and the calibrations are traceable to NML/ROC and NIST/USA.

2. The horn antenna, preamplifier (model: 8449B) and Spectrum Analyzer (model: FSP40) are used only for the measurement of emission frequency above 1GHz if tested.

3. The test was performed in Open Site No. C.

4. The FCC Site Registration No. is 656396.

5. The VCCI Site Registration No. is R-1626.

6. The CANADA Site Registration No. is IC 7450G-3.



A D T

Above 1GHz test:

DESCRIPTION & MANUFACTURER	MODEL NO.	SERIAL NO.	CALIBRATED DATE	CALIBRATED UNTIL
Agilent Spectrum Analyzer	E4446A	MY48250253	Aug. 23, 2010	Aug. 22, 2011
Agilent Pre-Selector	N9039A	MY46520310	Aug. 23, 2010	Aug. 22, 2011
Agilent Signal Generator	N5181A	MY49060347	July 30, 2010	July 29, 2011
LIG NEX1 Test Receiver	ER-265	L09068005	Oct. 25, 2010	Oct. 24, 2011
Mini-Circuits Pre-Amplifier	ZFL-1000VH2B	AMP-ZFL-04	Nov. 16, 2010	Nov. 15, 2011
Agilent Pre-Amplifier	8449B	3008A02465	Mar. 01, 2010	Feb. 28, 2011
Miteq Pre-Amplifier	AFS33-1800265 0-30-8P-44	881786	NA	NA
SCHWARZBECK Trilog Broadband Antenna	VULB 9168	9168-361	Apr. 28, 2010	Apr. 27, 2011
AISI Horn Antenna	AIH.8018	0000220091110	Nov. 22, 2010	Nov. 21, 2011
SCHWARZBECK Horn Antenna	BBHA 9170	9170-424	Oct. 08, 2010	Oct. 07, 2011
RF CABLE	NA	RF104-205 RF104-207 RF104-202	Dec. 28, 2010	Dec. 27, 2011
RF Cable	NA	CHHCAB_001	NA	NA
Software	ADT_Radiated_V8.7.05	NA	NA	NA
CT Antenna Tower & Turn Table	NA	NA	NA	NA

- Note: 1. The calibration interval of the above test instruments is 12 months and the calibrations are traceable to NML/ROC and NIST/USA.
 2. The horn antenna, preamplifier (model: 8449B) are used only for the measurement of emission frequency above 1GHz if tested.
 3. The test was performed in 966 Chamber No. H.
 4. The FCC Site Registration No. is 797305.
 5. The CANADA Site Registration No. is IC 7450H-3.

4.2.3 TEST PROCEDURES

- a. The EUT was placed on the top of a rotating table 0.8 meters above the ground at a 10 meter open site for below 1GHz and 3 meter chamber room for above 1GHz. The table was rotated 360 degrees to determine the position of the highest radiation.
- b. The EUT was set 3 meters away from the interference-receiving antenna, which was mounted on the top of a variable-height antenna tower.
- c. The height of antenna is varied from one meter to four meters above the ground to determine the maximum value of the field strength. Both horizontal and vertical polarizations of the antenna are set to make the measurement.
- d. For each suspected emission, the EUT was arranged to its worst case and then the antenna was tuned to heights from 1 meter to 4 meters and the rotatable table was turned from 0 degrees to 360 degrees to find the maximum reading.
- e. The test-receiver system was set to quasi-peak detect function and specified bandwidth with maximum hold mode when the test frequency is below 1 GHz.
- f. The test-receiver system was set to peak and average detect function and specified bandwidth with maximum hold mode when the test frequency is above 1 GHz. If the peak reading value also meets average limit, measurement with the average detector is unnecessary.

NOTE:

1. The resolution bandwidth and video bandwidth of test receiver/spectrum analyzer is 120kHz for Quasi-peak detection (QP) at frequency below 1GHz.
2. The resolution bandwidth of test receiver/spectrum analyzer is 1 MHz and the video bandwidth is 3 MHz for Peak detection (PK) at frequency above 1GHz.
3. The resolution bandwidth of test receiver/spectrum analyzer is 1 MHz and the video bandwidth is 10 Hz for Average detection (AV) at frequency above 1GHz.

4.2.4 DEVIATION FROM TEST STANDARD

No deviation

4.2.5 TEST SETUP

Below 1GHz test:

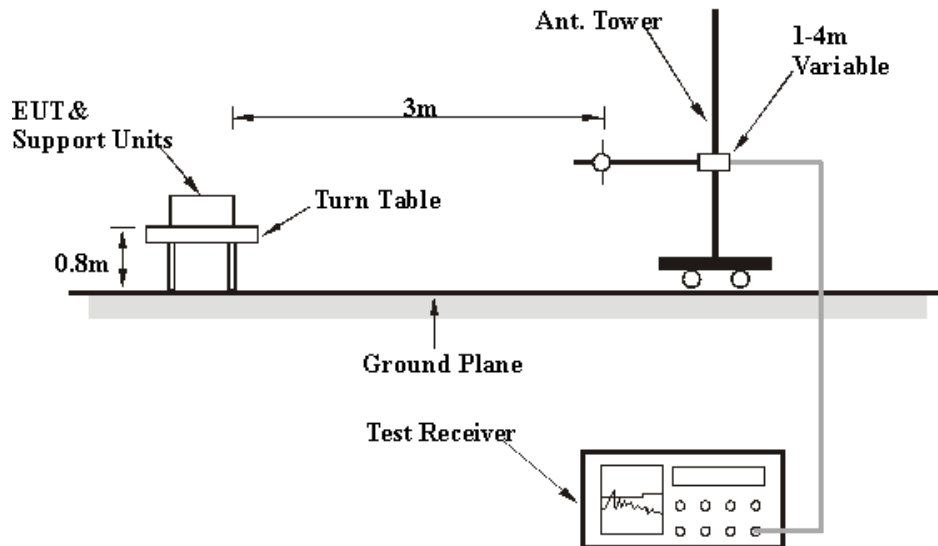

Above 1GHz test:

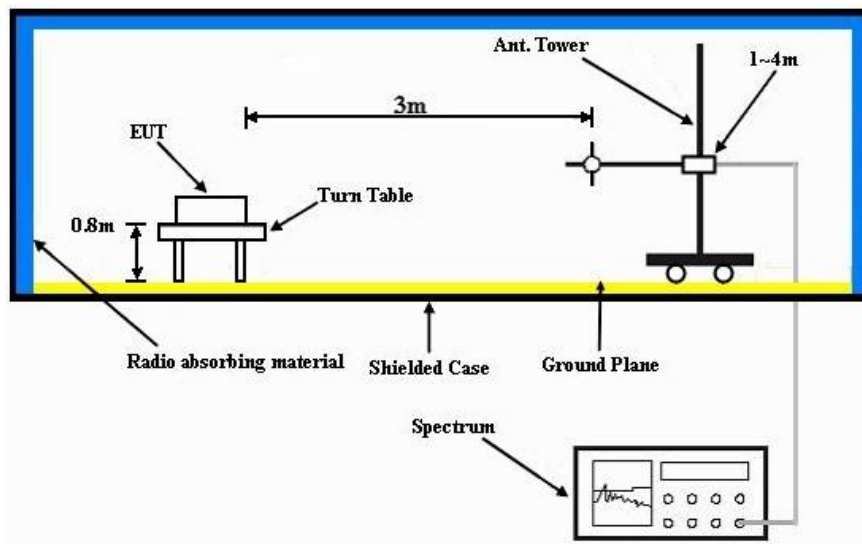

For the actual test configuration, please refer to the related item – Photographs of the Test Configuration.

4.2.6 EUT OPERATING CONDITIONS

Same as 4.1.6



A D T

4.2.7 TEST RESULTS

BELOW 1GHz WORST-CASE DATA : 802.11n (20MHz) OFDM MODULATION

EUT TEST CONDITION		MEASUREMENT DETAIL	
CHANNEL	Channel 6	FREQUENCY RANGE	Below 1000MHz
INPUT POWER	120Vac, 60 Hz	DETECTOR FUNCTION	Quasi-Peak
ENVIRONMENTAL CONDITIONS	17deg. C, 62%RH 1023 hPa	TESTED BY	Rex Huang

ANTENNA POLARITY & TEST DISTANCE: HORIZONTAL AT 3 M								
NO.	FREQ. (MHz)	EMISSION LEVEL (dBuV/m)	LIMIT (dBuV/m)	MARGIN (dB)	ANTENNA HEIGHT (m)	TABLE ANGLE (Degree)	RAW VALUE (dBuV)	CORRECTION FACTOR (dB/m)
1	124.97	35.1 QP	43.5	-8.4	1.50 H	282	22.09	13.00
2	250.03	32.0 QP	46.0	-14.0	1.00 H	284	18.62	13.42
3	374.97	33.3 QP	46.0	-12.7	1.00 H	323	16.22	17.12
4	500.02	38.1 QP	46.0	-7.9	1.25 H	343	17.98	20.10
5	624.96	38.5 QP	46.0	-7.5	2.00 H	360	15.75	22.71
6	640.00	36.0 QP	46.0	-10.1	1.25 H	11	13.03	22.92
7	874.95	34.0 QP	46.0	-12.0	1.00 H	51	7.62	26.37
ANTENNA POLARITY & TEST DISTANCE: VERTICAL AT 3 M								
NO.	FREQ. (MHz)	EMISSION LEVEL (dBuV/m)	LIMIT (dBuV/m)	MARGIN (dB)	ANTENNA HEIGHT (m)	TABLE ANGLE (Degree)	RAW VALUE (dBuV)	CORRECTION FACTOR (dB/m)
1	38.94	35.2 QP	40.0	-4.9	1.25 V	360	21.31	13.84
2	77.19	35.7 QP	40.0	-4.3	1.50 V	354	25.54	10.13
3	124.97	36.6 QP	43.5	-6.9	1.25 V	360	23.58	13.00
4	143.33	34.8 QP	43.5	-8.8	1.25 V	34	20.75	14.00
5	500.02	37.6 QP	46.0	-8.4	1.00 V	44	17.54	20.10
6	625.07	38.1 QP	46.0	-7.9	1.75 V	71	15.34	22.72
7	875.06	36.2 QP	46.0	-9.8	1.75 V	360	9.82	26.37

- REMARKS:**
1. Emission level (dBuV/m) = Raw Value (dBuV) + Correction Factor (dB/m).
 2. Correction Factor (dB/m) = Antenna Factor (dB/m) + Cable Factor (dB).
 3. The other emission levels were very low against the limit.
 4. Margin value = Emission level – Limit value.



A D T

ABOVE 1GHz WORST-CASE DATA

802.11b DSSS MODULATION

EUT TEST CONDITION		MEASUREMENT DETAIL	
CHANNEL	Channel 1	FREQUENCY RANGE	1 ~ 25GHz
INPUT POWER	120Vac, 60 Hz	DETECTOR FUNCTION	Peak (PK) Average (AV)
ENVIRONMENTAL CONDITIONS	23deg. C, 71%RH 1023 hPa	TESTED BY	Rex Huang

ANTENNA POLARITY & TEST DISTANCE: HORIZONTAL AT 3 M

NO.	FREQ. (MHz)	EMISSION LEVEL (dBuV/m)	LIMIT (dBuV/m)	MARGIN (dB)	ANTENNA HEIGHT (m)	TABLE ANGLE (Degree)	RAW VALUE (dBuV)	CORRECTION FACTOR (dB/m)
1	2390.00	61.5 PK	74.0	-12.5	1.00 H	292	29.62	31.88
2	2390.00	50.8 AV	54.0	-3.2	1.00 H	292	18.92	31.88
3	*2412.00	113.7 PK			1.00 H	292	81.75	31.95
4	*2412.00	111.2 AV			1.00 H	292	79.25	31.95
5	4824.00	54.3 PK	74.0	-19.7	1.03 H	42	13.08	41.22
6	4824.00	49.2 AV	54.0	-4.8	1.03 H	42	7.98	41.22

ANTENNA POLARITY & TEST DISTANCE: VERTICAL AT 3 M

NO.	FREQ. (MHz)	EMISSION LEVEL (dBuV/m)	LIMIT (dBuV/m)	MARGIN (dB)	ANTENNA HEIGHT (m)	TABLE ANGLE (Degree)	RAW VALUE (dBuV)	CORRECTION FACTOR (dB/m)
1	2390.00	58.7 PK	74.0	-15.3	1.06 V	27	26.82	31.88
2	2390.00	44.4 AV	54.0	-9.6	1.06 V	27	12.52	31.88
3	*2412.00	101.3 PK			1.06 V	27	69.35	31.95
4	*2412.00	98.6 AV			1.06 V	27	66.65	31.95
5	4824.00	57.0 PK	74.0	-17.0	1.00 V	260	15.78	41.22
6	4824.00	52.8 AV	54.0	-1.2	1.00 V	260	11.58	41.22

- REMARKS:**
1. Emission level (dBuV/m) = Raw Value (dBuV) + Correction Factor (dB/m).
 2. Correction Factor (dB/m) = Antenna Factor (dB/m) + Cable Factor (dB).
 3. The other emission levels were very low against the limit.
 4. Margin value = Emission level – Limit value.
 5. “ * “: Fundamental frequency.



A D T

EUT TEST CONDITION		MEASUREMENT DETAIL	
CHANNEL	Channel 6	FREQUENCY RANGE	1 ~ 25GHz
INPUT POWER	120Vac, 60 Hz	DETECTOR FUNCTION	Peak (PK) Average (AV)
ENVIRONMENTAL CONDITIONS	23deg. C, 71%RH 1023 hPa	TESTED BY	Rex Huang

ANTENNA POLARITY & TEST DISTANCE: HORIZONTAL AT 3 M								
NO.	FREQ. (MHz)	EMISSION LEVEL (dBuV/m)	LIMIT (dBuV/m)	MARGIN (dB)	ANTENNA HEIGHT (m)	TABLE ANGLE (Degree)	RAW VALUE (dBuV)	CORRECTION FACTOR (dB/m)
1	*2437.00	114.1 PK			1.00 H	293	82.06	32.04
2	*2437.00	111.1 AV			1.00 H	293	79.06	32.04
3	4874.00	54.7 PK	74.0	-19.3	1.04 H	41	13.34	41.36
4	4874.00	50.6 AV	54.0	-3.4	1.04 H	41	9.24	41.36
5	7311.00	53.7 PK	74.0	-20.3	1.00 H	282	8.03	45.67
6	7311.00	42.5 AV	54.0	-11.5	1.00 H	282	-3.17	45.67
ANTENNA POLARITY & TEST DISTANCE: VERTICAL AT 3 M								
NO.	FREQ. (MHz)	EMISSION LEVEL (dBuV/m)	LIMIT (dBuV/m)	MARGIN (dB)	ANTENNA HEIGHT (m)	TABLE ANGLE (Degree)	RAW VALUE (dBuV)	CORRECTION FACTOR (dB/m)
1	*2437.00	102.1 PK			1.07 V	27	70.06	32.04
2	*2437.00	99.6 AV			1.07 V	27	67.56	32.04
3	4874.00	56.2 PK	74.0	-17.8	1.00 V	258	14.84	41.36
4	4874.00	53.2 AV	54.0	-0.8	1.00 V	258	11.84	41.36
5	7311.00	55.2 PK	74.0	-18.8	1.14 V	225	9.53	45.67
6	7311.00	44.3 AV	54.0	-9.7	1.14 V	225	-1.37	45.67

- REMARKS:**
1. Emission level (dBuV/m) = Raw Value (dBuV) + Correction Factor (dB/m).
 2. Correction Factor (dB/m) = Antenna Factor (dB/m) + Cable Factor (dB).
 3. The other emission levels were very low against the limit.
 4. Margin value = Emission level – Limit value.
 5. “ * “: Fundamental frequency.



A D T

EUT TEST CONDITION		MEASUREMENT DETAIL	
CHANNEL	Channel 11	FREQUENCY RANGE	1 ~ 25GHz
INPUT POWER	120Vac, 60 Hz	DETECTOR FUNCTION	Peak (PK) Average (AV)
ENVIRONMENTAL CONDITIONS	23deg. C, 71%RH 1023 hPa	TESTED BY	Rex Huang

ANTENNA POLARITY & TEST DISTANCE: HORIZONTAL AT 3 M

NO.	FREQ. (MHz)	EMISSION LEVEL (dBuV/m)	LIMIT (dBuV/m)	MARGIN (dB)	ANTENNA HEIGHT (m)	TABLE ANGLE (Degree)	RAW VALUE (dBuV)	CORRECTION FACTOR (dB/m)
1	*2462.00	114.3 PK			1.00 H	293	82.18	32.12
2	*2462.00	111.7 AV			1.00 H	293	79.58	32.12
3	2500.00	64.1 PK	74.0	-9.9	1.00 H	293	31.85	32.25
4	2500.00	52.6 AV	54.0	-1.4	1.00 H	293	20.35	32.25
5	4924.00	55.2 PK	74.0	-18.8	1.02 H	43	13.72	41.48
6	4924.00	51.2 AV	54.0	-2.8	1.02 H	43	9.72	41.48
7	7386.00	53.3 PK	74.0	-20.7	1.00 H	287	7.39	45.91
8	7386.00	41.8 AV	54.0	-12.2	1.00 H	287	-4.11	45.91

ANTENNA POLARITY & TEST DISTANCE: VERTICAL AT 3 M

NO.	FREQ. (MHz)	EMISSION LEVEL (dBuV/m)	LIMIT (dBuV/m)	MARGIN (dB)	ANTENNA HEIGHT (m)	TABLE ANGLE (Degree)	RAW VALUE (dBuV)	CORRECTION FACTOR (dB/m)
1	*2462.00	102.0 PK			1.03 V	26	69.88	32.12
2	*2462.00	99.7 AV			1.03 V	26	67.58	32.12
3	2500.00	60.1 PK	74.0	-13.9	1.03 V	26	27.85	32.25
4	2500.00	46.7 AV	54.0	-7.3	1.03 V	26	14.45	32.25
5	4924.00	56.5 PK	74.0	-17.5	1.00 V	271	15.02	41.48
6	4924.00	53.2 AV	54.0	-0.8	1.00 V	271	11.72	41.48
7	7386.00	54.9 PK	74.0	-19.1	1.17 V	127	8.99	45.91
8	7386.00	43.0 AV	54.0	-11.0	1.17 V	127	-2.91	45.91

- REMARKS:**
1. Emission level (dBuV/m) = Raw Value (dBuV) + Correction Factor (dB/m).
 2. Correction Factor (dB/m) = Antenna Factor (dB/m) + Cable Factor (dB).
 3. The other emission levels were very low against the limit.
 4. Margin value = Emission level – Limit value.
 5. “ * “: Fundamental frequency.

RESTRICTED BANDEDGE (802.11b MODE, CH1, HORIZONTAL)

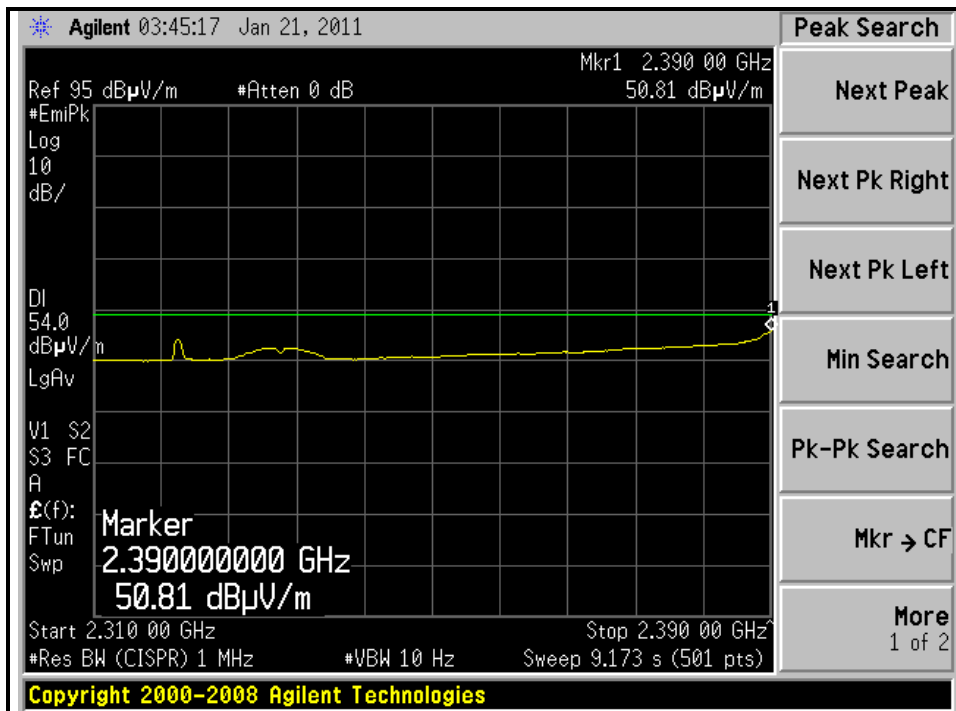
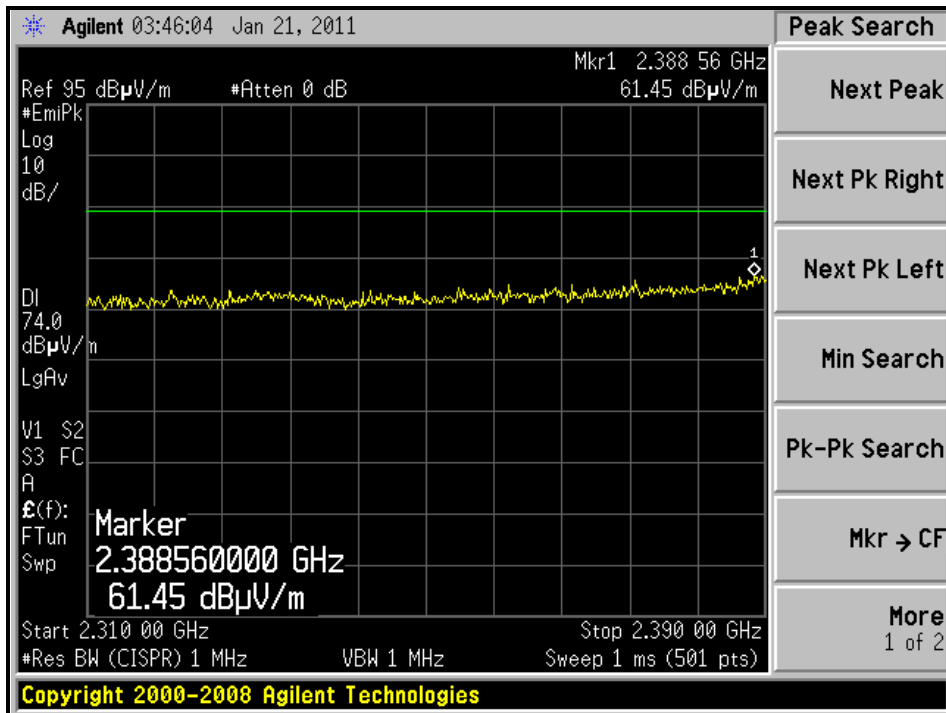



A D T

RESTRICTED BANDEDGE (802.11b MODE, CH1, VERTICAL)

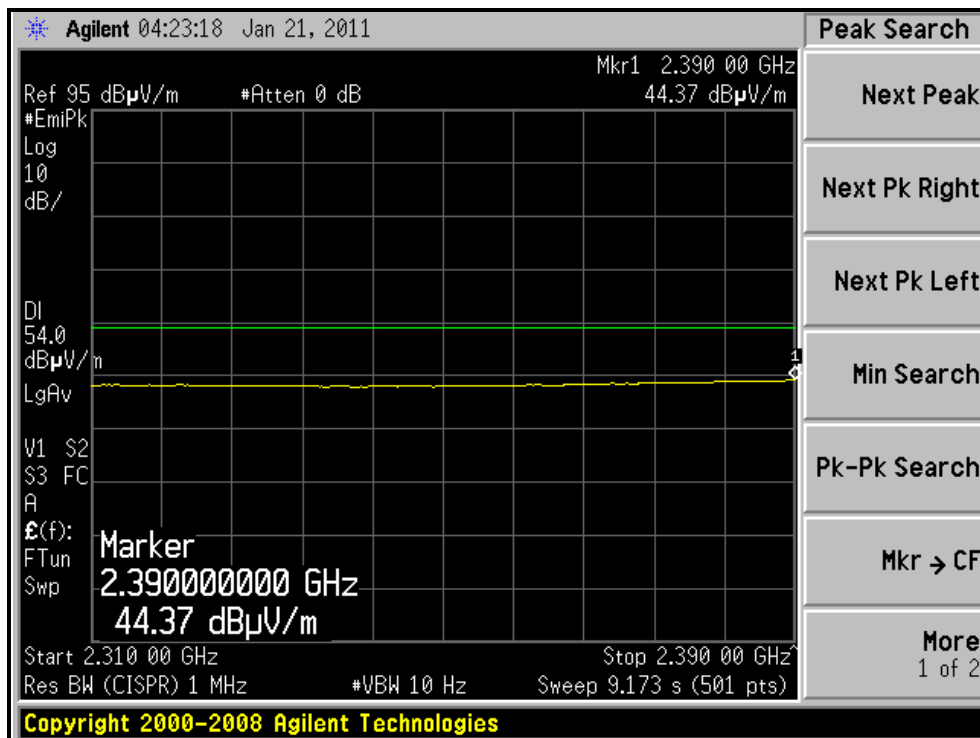
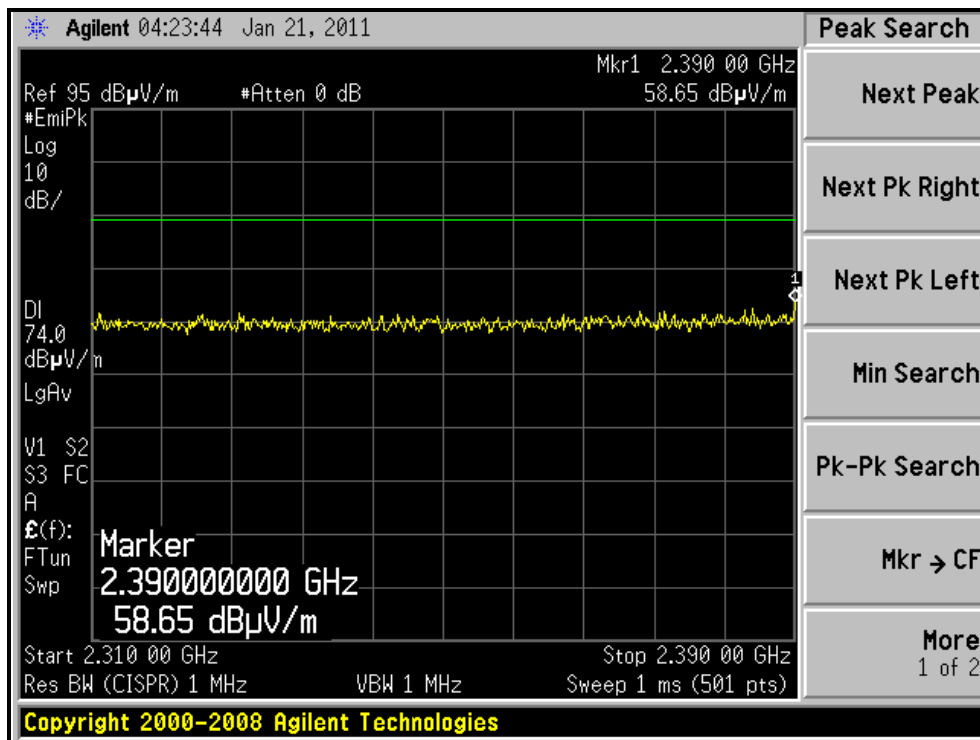

RESTRICTED BANDEDGE (802.11b MODE, CH11, HORIZONTAL)

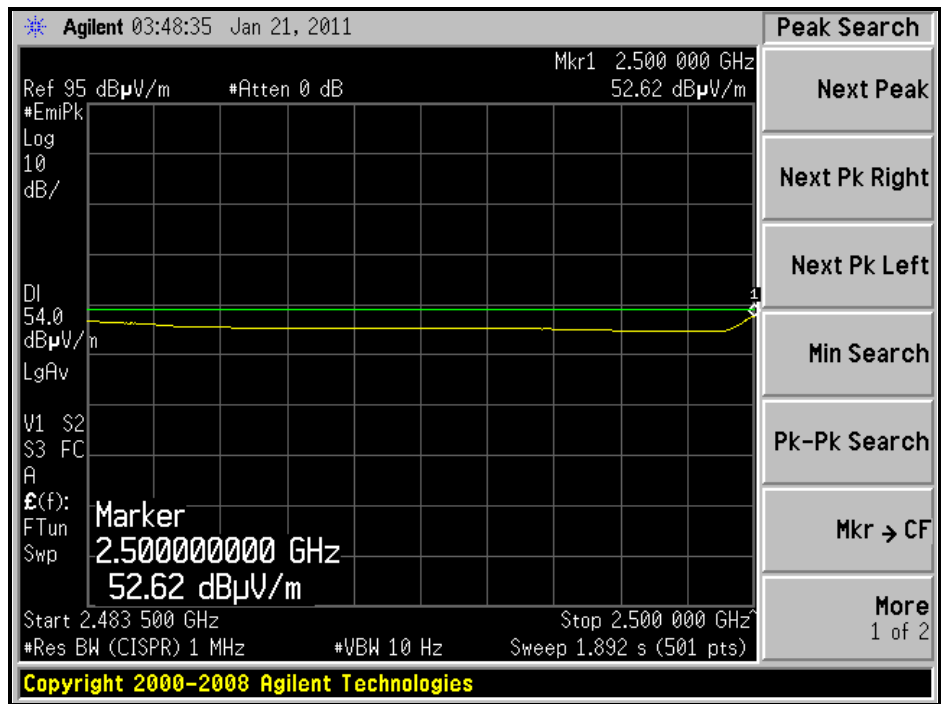
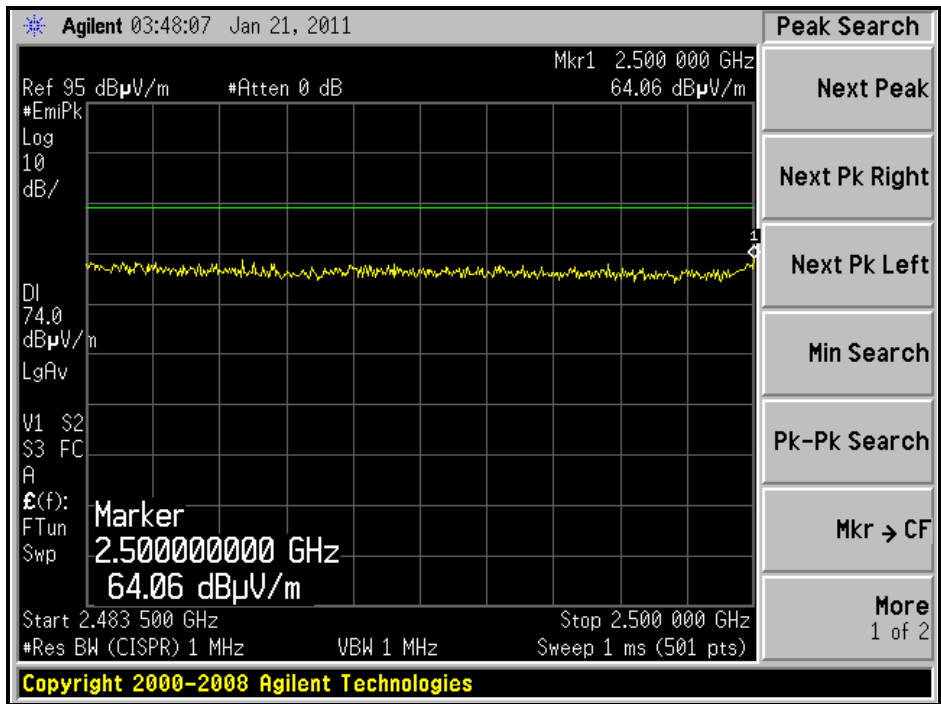



A D T

RESTRICTED BANDEDGE (802.11b MODE, CH11, VERTICAL)

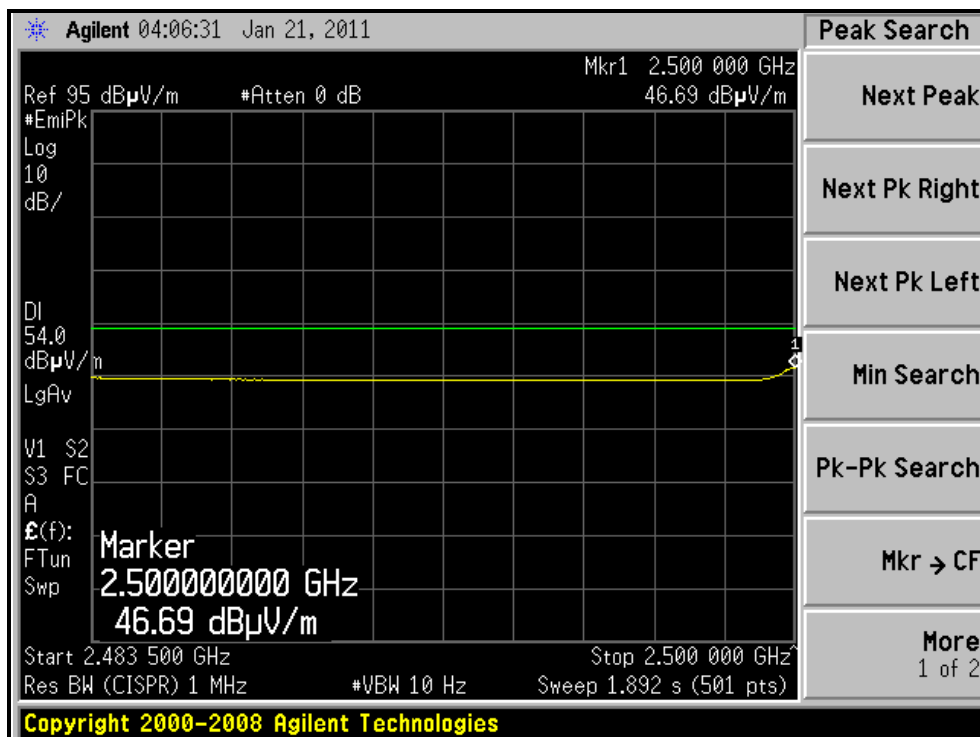
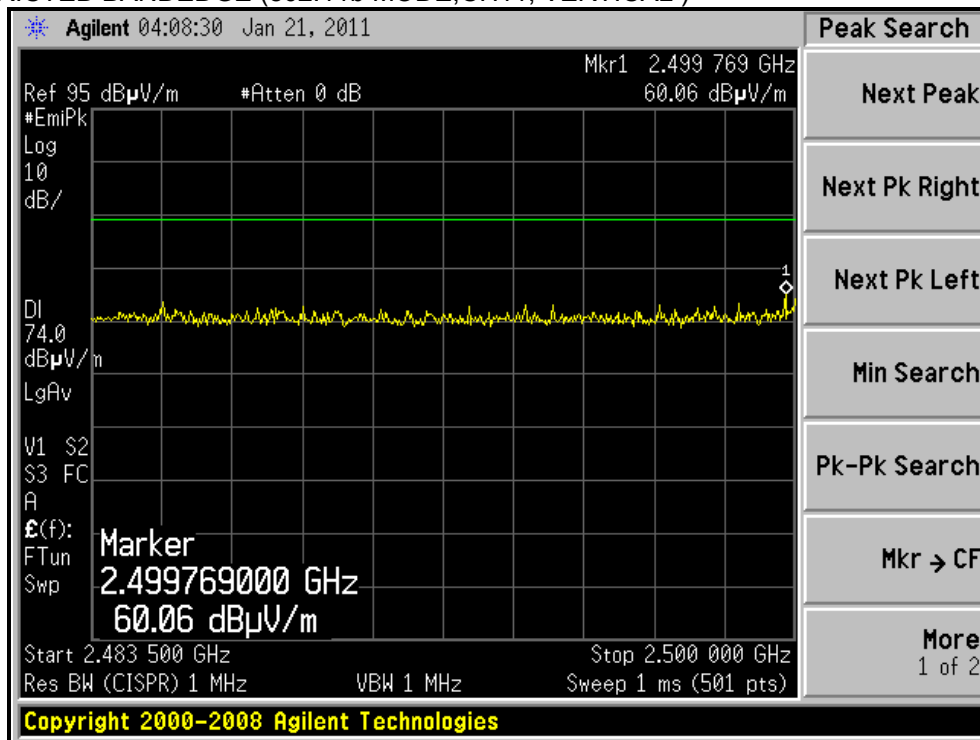



A D T

802.11g OFDM MODULATION

EUT TEST CONDITION		MEASUREMENT DETAIL	
CHANNEL	Channel 1	FREQUENCY RANGE	1 ~ 25GHz
INPUT POWER	120Vac, 60 Hz	DETECTOR FUNCTION	Peak (PK) Average (AV)
ENVIRONMENTAL CONDITIONS	23deg. C, 71%RH 1023 hPa	TESTED BY	Rex Huang

ANTENNA POLARITY & TEST DISTANCE: HORIZONTAL AT 3 M

NO.	FREQ. (MHz)	EMISSION LEVEL (dBuV/m)	LIMIT (dBuV/m)	MARGIN (dB)	ANTENNA HEIGHT (m)	TABLE ANGLE (Degree)	RAW VALUE (dBuV)	CORRECTION FACTOR (dB/m)
1	2390.00	66.5 PK	74.0	-7.5	1.00 H	294	34.62	31.88
2	2390.00	53.5 AV	54.0	-0.5	1.00 H	294	21.62	31.88
3	*2412.00	110.5 PK			1.00 H	294	78.55	31.95
4	*2412.00	100.0 AV			1.00 H	294	68.05	31.95
5	4824.00	48.6 PK	74.0	-25.4	1.02 H	51	7.38	41.22
6	4824.00	35.4 AV	54.0	-18.6	1.02 H	51	-5.82	41.22

ANTENNA POLARITY & TEST DISTANCE: VERTICAL AT 3 M

NO.	FREQ. (MHz)	EMISSION LEVEL (dBuV/m)	LIMIT (dBuV/m)	MARGIN (dB)	ANTENNA HEIGHT (m)	TABLE ANGLE (Degree)	RAW VALUE (dBuV)	CORRECTION FACTOR (dB/m)
1	2390.00	57.3 PK	74.0	-16.7	1.05 V	28	25.42	31.88
2	2390.00	45.1 AV	54.0	-8.9	1.05 V	28	13.22	31.88
3	*2412.00	97.1 PK			1.05 V	28	65.15	31.95
4	*2412.00	87.4 AV			1.05 V	28	55.45	31.95
5	4824.00	50.1 PK	74.0	-23.9	1.00 V	274	8.88	41.22
6	4824.00	37.2 AV	54.0	-16.8	1.00 V	274	-4.02	41.22

- REMARKS:**
1. Emission level (dBuV/m) = Raw Value (dBuV) + Correction Factor (dB/m).
 2. Correction Factor (dB/m) = Antenna Factor (dB/m) + Cable Factor (dB).
 3. The other emission levels were very low against the limit.
 4. Margin value = Emission level – Limit value.
 5. “ * “: Fundamental frequency.



A D T

EUT TEST CONDITION		MEASUREMENT DETAIL	
CHANNEL	Channel 6	FREQUENCY RANGE	1 ~ 25GHz
INPUT POWER	120Vac, 60 Hz	DETECTOR FUNCTION	Peak (PK) Average (AV)
ENVIRONMENTAL CONDITIONS	23deg. C, 71%RH 1023 hPa	TESTED BY	Rex Huang

ANTENNA POLARITY & TEST DISTANCE: HORIZONTAL AT 3 M

NO.	FREQ. (MHz)	EMISSION LEVEL (dBuV/m)	LIMIT (dBuV/m)	MARGIN (dB)	ANTENNA HEIGHT (m)	TABLE ANGLE (Degree)	RAW VALUE (dBuV)	CORRECTION FACTOR (dB/m)
1	2390.00	69.7 PK	74.0	-4.3	1.00 H	292	37.82	31.88
2	2390.00	52.4 AV	54.0	-1.6	1.00 H	292	20.52	31.88
3	*2437.00	117.9 PK			1.00 H	282	85.86	32.04
4	*2437.00	107.8 AV			1.00 H	282	75.76	32.04
5	2483.50	70.5 PK	74.0	-3.5	1.00 H	360	38.31	32.19
6	2483.50	53.2 AV	54.0	-0.8	1.00 H	360	21.01	32.19
7	4874.00	51.1 PK	74.0	-22.9	1.03 H	49	9.74	41.36
8	4874.00	37.6 AV	54.0	-16.4	1.03 H	49	-3.76	41.36
9	7311.00	54.2 PK	74.0	-19.8	1.05 H	254	8.53	45.67
10	7311.00	42.4 AV	54.0	-11.6	1.05 H	254	-3.27	45.67

ANTENNA POLARITY & TEST DISTANCE: VERTICAL AT 3 M

NO.	FREQ. (MHz)	EMISSION LEVEL (dBuV/m)	LIMIT (dBuV/m)	MARGIN (dB)	ANTENNA HEIGHT (m)	TABLE ANGLE (Degree)	RAW VALUE (dBuV)	CORRECTION FACTOR (dB/m)
1	*2437.00	104.6 PK			1.02 V	26	72.56	32.04
2	*2437.00	95.3 AV			1.02 V	26	63.26	32.04
3	4874.00	54.9 PK	74.0	-19.1	1.00 V	257	13.54	41.36
4	4874.00	40.8 AV	54.0	-13.2	1.00 V	257	-0.56	41.36
5	7311.00	55.4 PK	74.0	-18.6	1.21 V	246	9.73	45.67
6	7311.00	44.7 AV	54.0	-9.3	1.21 V	246	-0.97	45.67

- REMARKS:**
1. Emission level (dBuV/m) = Raw Value (dBuV) + Correction Factor (dB/m).
 2. Correction Factor (dB/m) = Antenna Factor (dB/m) + Cable Factor (dB).
 3. The other emission levels were very low against the limit.
 4. Margin value = Emission level – Limit value.
 5. “ * “: Fundamental frequency.



A D T

EUT TEST CONDITION		MEASUREMENT DETAIL	
CHANNEL	Channel 11	FREQUENCY RANGE	1 ~ 25GHz
INPUT POWER	120Vac, 60 Hz	DETECTOR FUNCTION	Peak (PK) Average (AV)
ENVIRONMENTAL CONDITIONS	23deg. C, 71%RH 1023 hPa	TESTED BY	Rex Huang

ANTENNA POLARITY & TEST DISTANCE: HORIZONTAL AT 3 M

NO.	FREQ. (MHz)	EMISSION LEVEL (dBuV/m)	LIMIT (dBuV/m)	MARGIN (dB)	ANTENNA HEIGHT (m)	TABLE ANGLE (Degree)	RAW VALUE (dBuV)	CORRECTION FACTOR (dB/m)
1	*2462.00	109.5 PK			1.00 H	293	77.38	32.12
2	*2462.00	98.7 AV			1.00 H	293	66.58	32.12
3	2483.50	65.4 PK	74.0	-8.6	1.00 H	293	33.21	32.19
4	2483.50	52.4 AV	54.0	-1.6	1.00 H	293	20.21	32.19
5	4924.00	49.6 PK	74.0	-24.4	1.00 H	54	8.12	41.48
6	4924.00	36.4 AV	54.0	-17.6	1.00 H	54	-5.08	41.48
7	7386.00	53.7 PK	74.0	-20.3	1.04 H	263	7.79	45.91
8	7386.00	42.1 AV	54.0	-11.9	1.04 H	263	-3.81	45.91

ANTENNA POLARITY & TEST DISTANCE: VERTICAL AT 3 M

NO.	FREQ. (MHz)	EMISSION LEVEL (dBuV/m)	LIMIT (dBuV/m)	MARGIN (dB)	ANTENNA HEIGHT (m)	TABLE ANGLE (Degree)	RAW VALUE (dBuV)	CORRECTION FACTOR (dB/m)
1	*2462.00	97.9 PK			1.03 V	27	65.78	32.12
2	*2462.00	87.3 AV			1.03 V	27	55.18	32.12
3	2483.50	59.3 PK	74.0	-14.7	1.03 V	27	27.11	32.19
4	2483.50	45.8 AV	54.0	-8.2	1.03 V	27	13.61	32.19
5	4924.00	51.6 PK	74.0	-22.4	1.00 V	268	10.12	41.48
6	4924.00	38.1 AV	54.0	-15.9	1.00 V	268	-3.38	41.48
7	7386.00	54.1 PK	74.0	-19.9	1.15 V	241	8.19	45.91
8	7386.00	42.4 AV	54.0	-11.6	1.15 V	241	-3.51	45.91

- REMARKS:**
1. Emission level (dBuV/m) = Raw Value (dBuV) + Correction Factor (dB/m).
 2. Correction Factor (dB/m) = Antenna Factor (dB/m) + Cable Factor (dB).
 3. The other emission levels were very low against the limit.
 4. Margin value = Emission level – Limit value.
 5. “ * “: Fundamental frequency.



A D T

RESTRICTED BANDEDGE (802.11g MODE, CH1, HORIZONTAL)

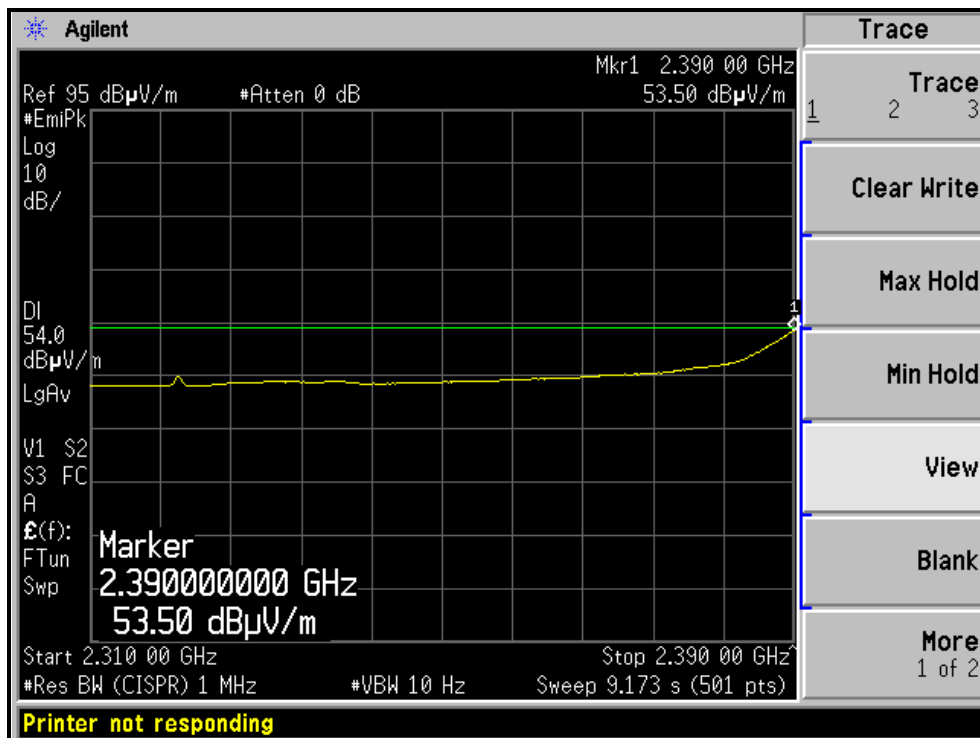
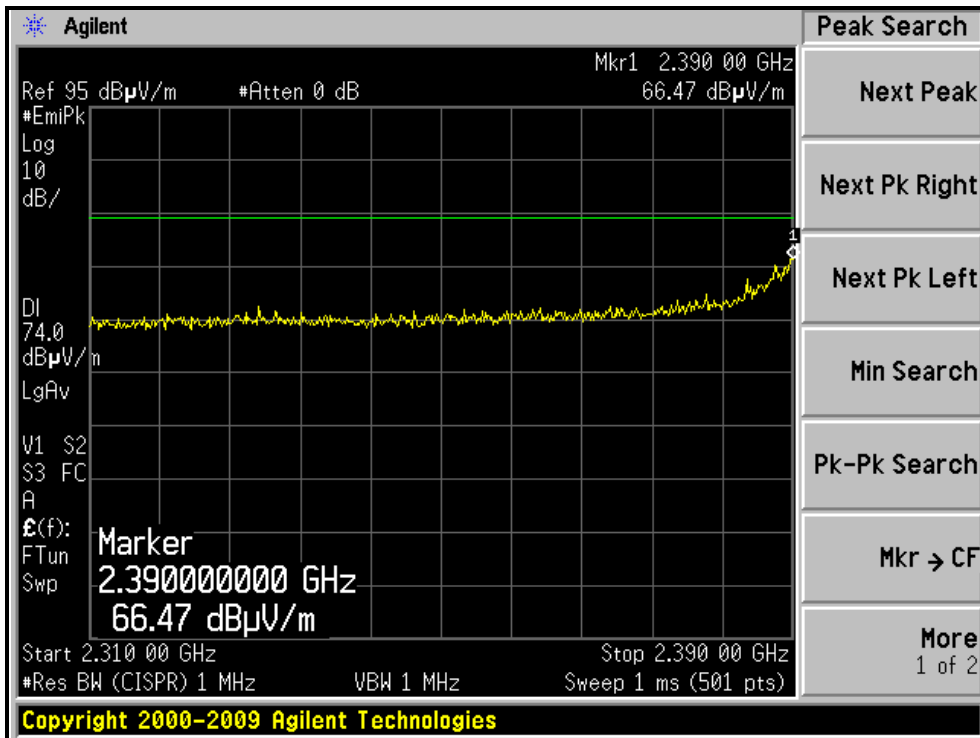



A D T

RESTRICTED BANDEDGE (802.11g MODE,CH1, VERTICAL)

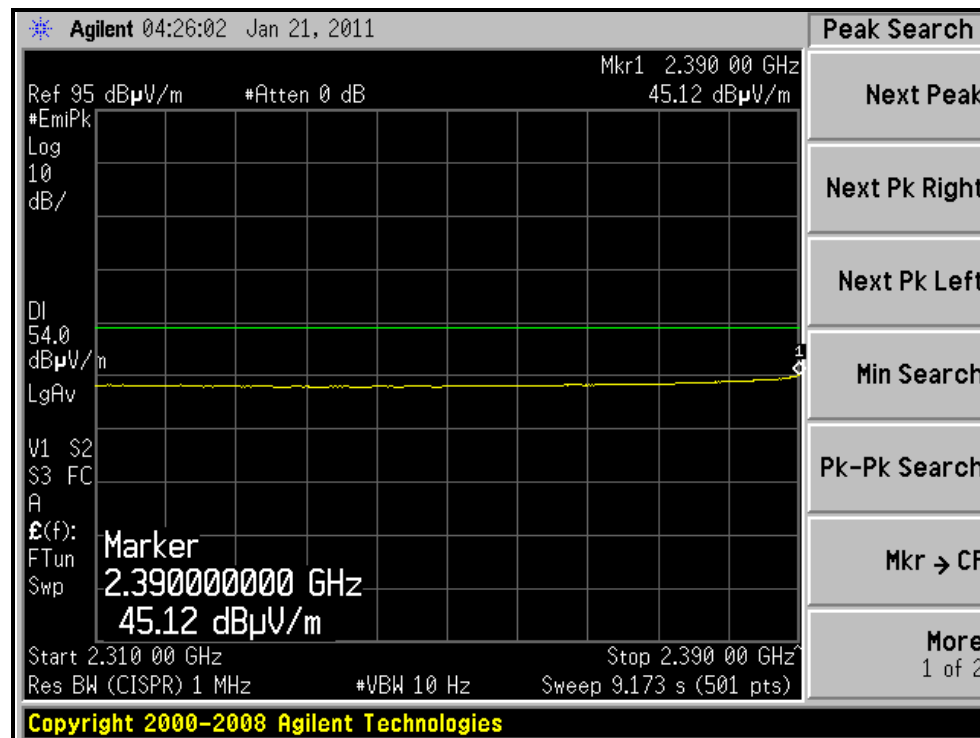
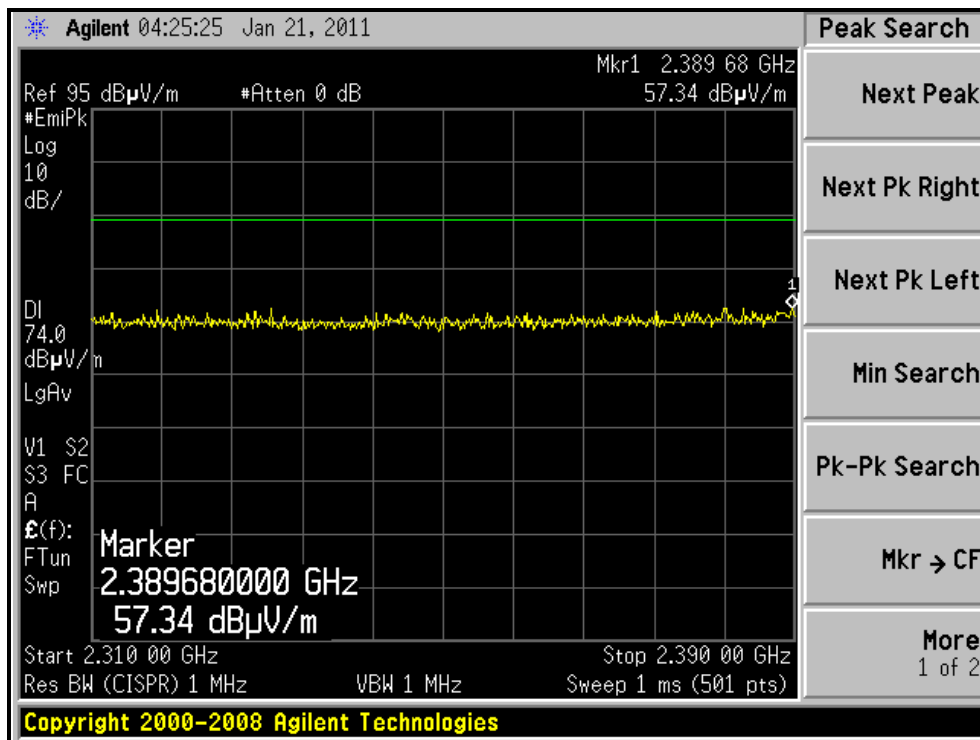



A D T

RESTRICTED BANDEDGE (802.11g MODE, CH11, HORIZONTAL)

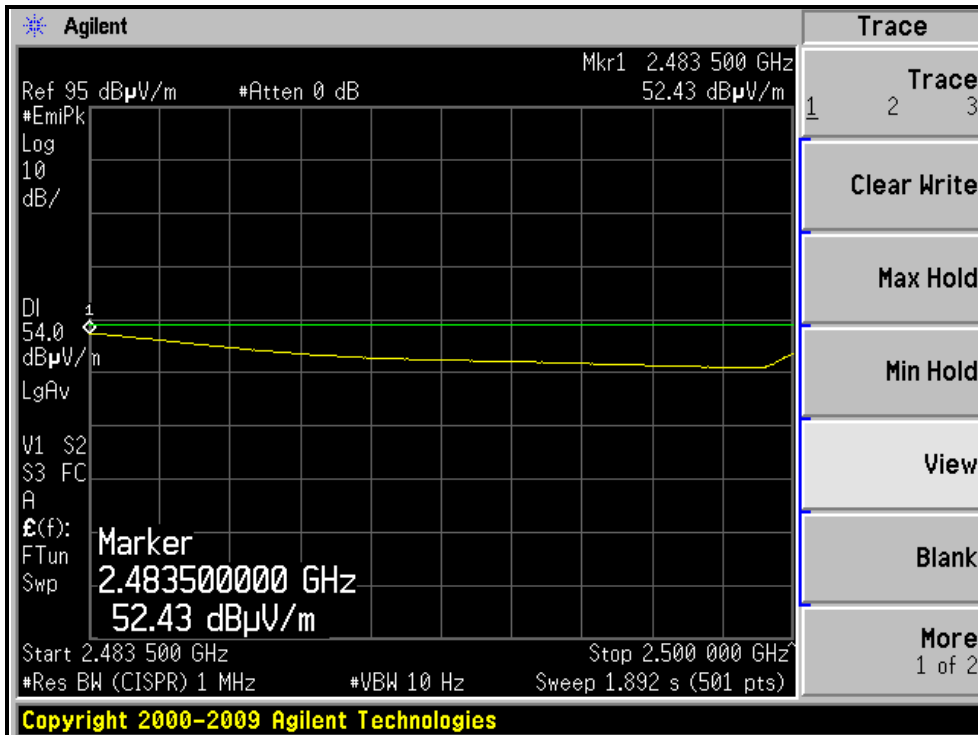
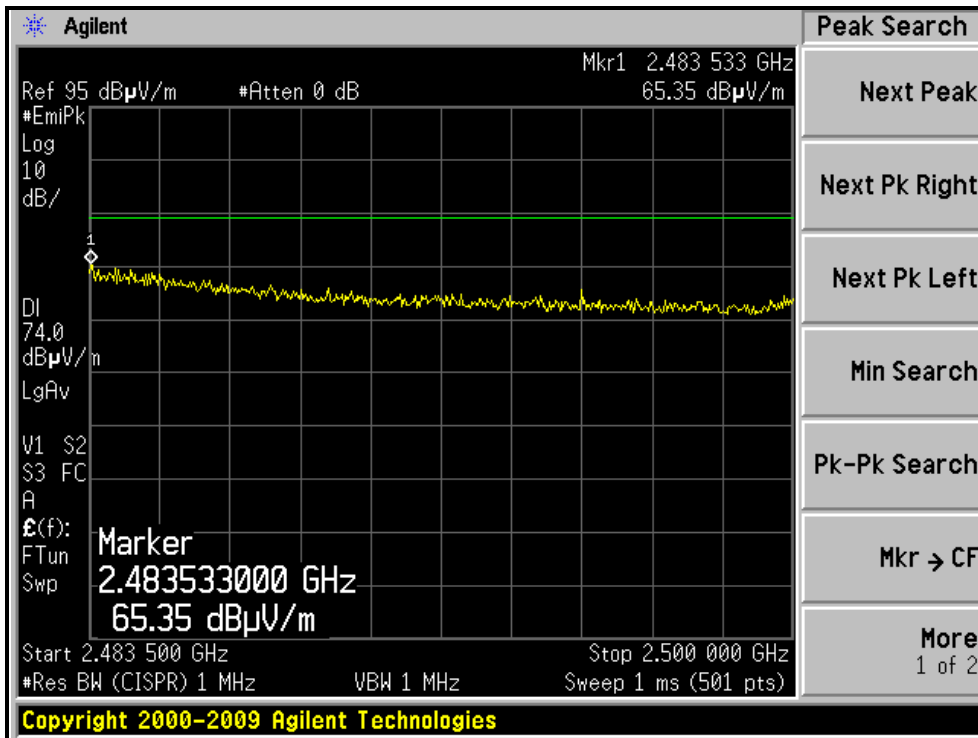

RESTRICTED BANDEDGE (802.11g MODE, CH11, VERTICAL)

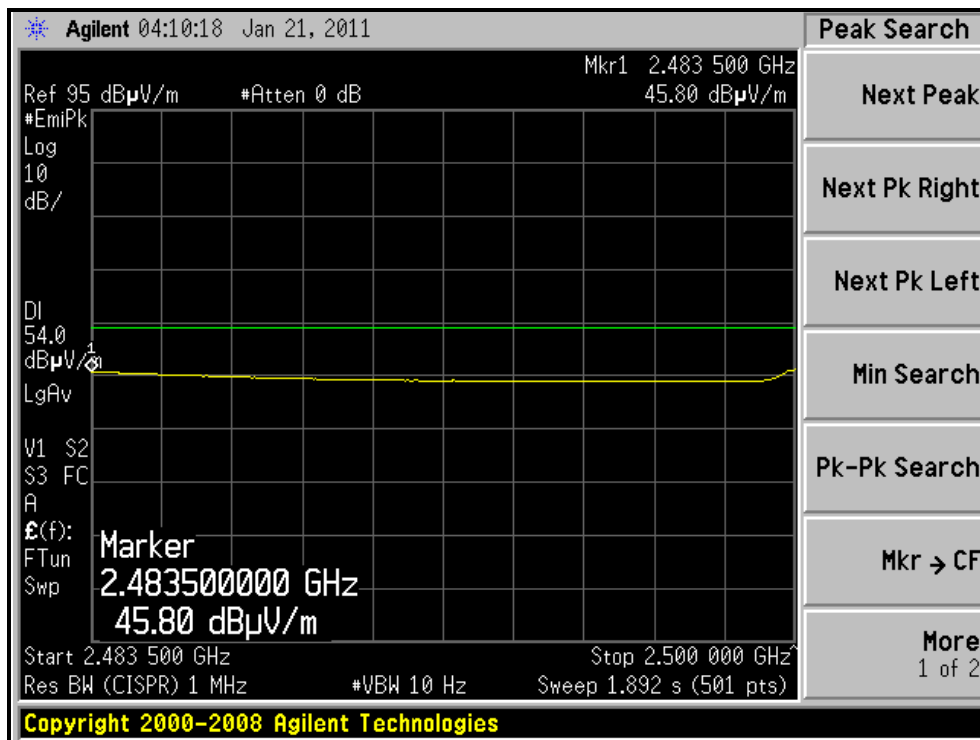
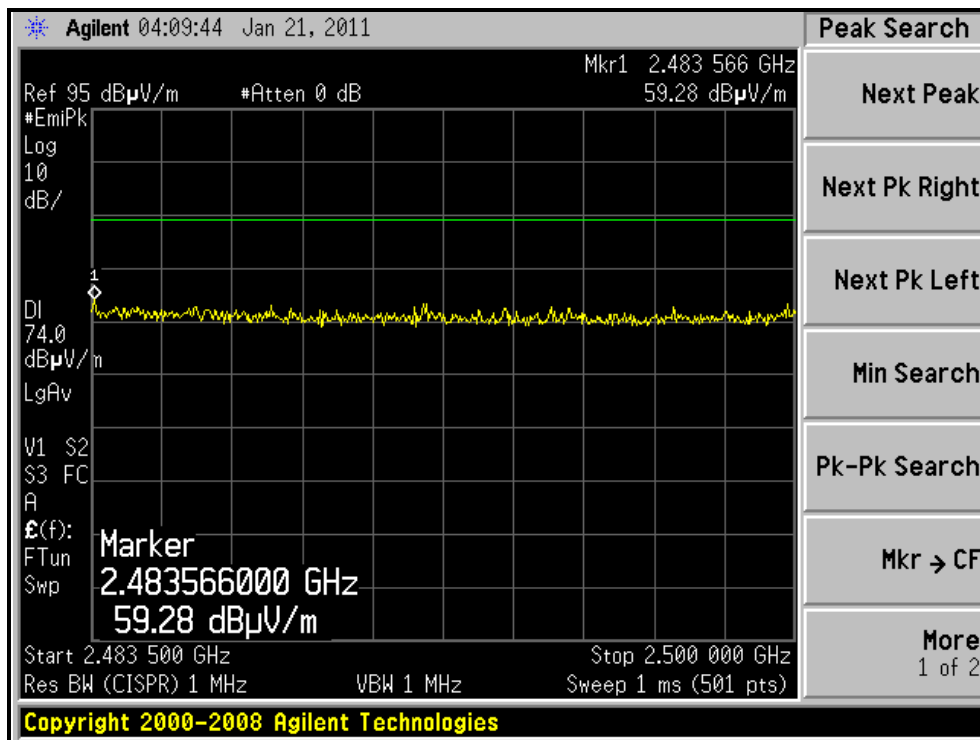



A D T

802.11n (20MHz) OFDM MODULATION

EUT TEST CONDITION		MEASUREMENT DETAIL	
CHANNEL	Channel 1	FREQUENCY RANGE	1 ~ 25GHz
INPUT POWER	120Vac, 60 Hz	DETECTOR FUNCTION	Peak (PK) Average (AV)
ENVIRONMENTAL CONDITIONS	23deg. C, 71%RH 1023 hPa	TESTED BY	Rex Huang

ANTENNA POLARITY & TEST DISTANCE: HORIZONTAL AT 3 M

NO.	FREQ. (MHz)	EMISSION LEVEL (dBuV/m)	LIMIT (dBuV/m)	MARGIN (dB)	ANTENNA HEIGHT (m)	TABLE ANGLE (Degree)	RAW VALUE (dBuV)	CORRECTION FACTOR (dB/m)
1	2390.00	67.1 PK	74.0	-6.9	1.00 H	294	35.22	31.88
2	2390.00	53.4 AV	54.0	-0.6	1.00 H	294	21.52	31.88
3	*2412.00	109.9 PK			1.00 H	294	77.95	31.95
4	*2412.00	98.8 AV			1.00 H	294	66.85	31.95
5	4824.00	48.2 PK	74.0	-25.8	1.04 H	68	6.98	41.22
6	4824.00	34.3 AV	54.0	-19.7	1.04 H	68	-6.92	41.22

ANTENNA POLARITY & TEST DISTANCE: VERTICAL AT 3 M

NO.	FREQ. (MHz)	EMISSION LEVEL (dBuV/m)	LIMIT (dBuV/m)	MARGIN (dB)	ANTENNA HEIGHT (m)	TABLE ANGLE (Degree)	RAW VALUE (dBuV)	CORRECTION FACTOR (dB/m)
1	2390.00	61.4 PK	74.0	-12.6	1.20 V	34	29.52	31.88
2	2390.00	47.4 AV	54.0	-6.6	1.20 V	34	15.52	31.88
3	*2412.00	102.3 PK			1.20 V	34	70.35	31.95
4	*2412.00	91.1 AV			1.20 V	34	59.15	31.95
5	4824.00	50.2 PK	74.0	-23.8	1.00 V	265	8.98	41.22
6	4824.00	37.4 AV	54.0	-16.6	1.00 V	265	-3.82	41.22

- REMARKS:**
1. Emission level (dBuV/m) = Raw Value (dBuV) + Correction Factor (dB/m).
 2. Correction Factor (dB/m) = Antenna Factor (dB/m) + Cable Factor (dB).
 3. The other emission levels were very low against the limit.
 4. Margin value = Emission level – Limit value.
 5. “ * “: Fundamental frequency.



A D T

EUT TEST CONDITION		MEASUREMENT DETAIL	
CHANNEL	Channel 6	FREQUENCY RANGE	1 ~ 25GHz
INPUT POWER	120Vac, 60 Hz	DETECTOR FUNCTION	Peak (PK) Average (AV)
ENVIRONMENTAL CONDITIONS	23deg. C, 71%RH 1023 hPa	TESTED BY	Rex Huang

ANTENNA POLARITY & TEST DISTANCE: HORIZONTAL AT 3 M								
NO.	FREQ. (MHz)	EMISSION LEVEL (dBuV/m)	LIMIT (dBuV/m)	MARGIN (dB)	ANTENNA HEIGHT (m)	TABLE ANGLE (Degree)	RAW VALUE (dBuV)	CORRECTION FACTOR (dB/m)
1	2390.00	70.3 PK	74.0	-3.7	1.00 H	293	38.42	31.88
2	2390.00	51.6 AV	54.0	-2.4	1.00 H	293	19.72	31.88
3	*2437.00	117.0 PK			1.00 H	294	84.96	32.04
4	*2437.00	106.7 AV			1.00 H	294	74.66	32.04
5	2483.50	67.9 PK	74.0	-6.1	1.00 H	294	35.71	32.19
6	2483.50	53.0 AV	54.0	-1.0	1.00 H	294	20.81	32.19
7	4874.00	51.3 PK	74.0	-22.7	1.06 H	42	9.94	41.36
8	4874.00	37.9 AV	54.0	-16.1	1.06 H	42	-3.46	41.36
9	7311.00	54.1 PK	74.0	-19.9	1.06 H	253	8.43	45.67
10	7311.00	42.0 AV	54.0	-12.0	1.06 H	253	-3.67	45.67
ANTENNA POLARITY & TEST DISTANCE: VERTICAL AT 3 M								
NO.	FREQ. (MHz)	EMISSION LEVEL (dBuV/m)	LIMIT (dBuV/m)	MARGIN (dB)	ANTENNA HEIGHT (m)	TABLE ANGLE (Degree)	RAW VALUE (dBuV)	CORRECTION FACTOR (dB/m)
1	*2437.00	109.3 PK			1.18 V	232	77.26	32.04
2	*2437.00	98.5 AV			1.18 V	232	66.46	32.04
3	4874.00	54.6 PK	74.0	-19.4	1.00 V	256	13.24	41.36
4	4874.00	40.6 AV	54.0	-13.4	1.00 V	256	-0.76	41.36
5	7311.00	54.3 PK	74.0	-19.7	1.20 V	351	8.63	45.67
6	7311.00	42.1 AV	54.0	-11.9	1.20 V	351	-3.57	45.67

- REMARKS:**
1. Emission level (dBuV/m) = Raw Value (dBuV) + Correction Factor (dB/m).
 2. Correction Factor (dB/m) = Antenna Factor (dB/m) + Cable Factor (dB).
 3. The other emission levels were very low against the limit.
 4. Margin value = Emission level – Limit value.
 5. “ * “: Fundamental frequency.



A D T

EUT TEST CONDITION		MEASUREMENT DETAIL	
CHANNEL	Channel 11	FREQUENCY RANGE	1 ~ 25GHz
INPUT POWER	120Vac, 60 Hz	DETECTOR FUNCTION	Peak (PK) Average (AV)
ENVIRONMENTAL CONDITIONS	23deg. C, 71%RH 1023 hPa	TESTED BY	Rex Huang

ANTENNA POLARITY & TEST DISTANCE: HORIZONTAL AT 3 M

NO.	FREQ. (MHz)	EMISSION LEVEL (dBuV/m)	LIMIT (dBuV/m)	MARGIN (dB)	ANTENNA HEIGHT (m)	TABLE ANGLE (Degree)	RAW VALUE (dBuV)	CORRECTION FACTOR (dB/m)
1	*2462.00	108.4 PK			1.00 H	294	76.28	32.12
2	*2462.00	98.0 AV			1.00 H	294	65.88	32.12
3	2483.50	66.7 PK	74.0	-7.3	1.00 H	294	34.51	32.19
4	2483.50	53.4 AV	54.0	-0.6	1.00 H	294	21.21	32.19
5	4924.00	48.9 PK	74.0	-25.1	1.03 H	54	7.42	41.48
6	4924.00	35.2 AV	54.0	-18.8	1.03 H	54	-6.28	41.48
7	7386.00	53.8 PK	74.0	-20.2	1.07 H	265	7.89	45.91
8	7386.00	41.6 AV	54.0	-12.4	1.07 H	265	-4.31	45.91

ANTENNA POLARITY & TEST DISTANCE: VERTICAL AT 3 M

NO.	FREQ. (MHz)	EMISSION LEVEL (dBuV/m)	LIMIT (dBuV/m)	MARGIN (dB)	ANTENNA HEIGHT (m)	TABLE ANGLE (Degree)	RAW VALUE (dBuV)	CORRECTION FACTOR (dB/m)
1	*2462.00	100.0 PK			1.13 V	25	67.88	32.12
2	*2462.00	89.1 AV			1.13 V	25	56.98	32.12
3	2483.50	60.3 PK	74.0	-13.7	1.13 V	25	28.11	32.19
4	2483.50	47.6 AV	54.0	-6.4	1.13 V	25	15.41	32.19
5	4924.00	51.3 PK	74.0	-22.7	1.00 V	261	9.82	41.48
6	4924.00	37.6 AV	54.0	-16.4	1.00 V	261	-3.88	41.48
7	7386.00	54.0 PK	74.0	-20.0	1.14 V	243	8.09	45.91
8	7386.00	41.7 AV	54.0	-12.3	1.14 V	243	-4.21	45.91

- REMARKS:**
1. Emission level (dBuV/m) = Raw Value (dBuV) + Correction Factor (dB/m).
 2. Correction Factor (dB/m) = Antenna Factor (dB/m) + Cable Factor (dB).
 3. The other emission levels were very low against the limit.
 4. Margin value = Emission level – Limit value.
 5. “ * “: Fundamental frequency.



A D T

RESTRICTED BANDEDGE (802.11n (20MHz) MODE,CH1, HORIZONTAL)

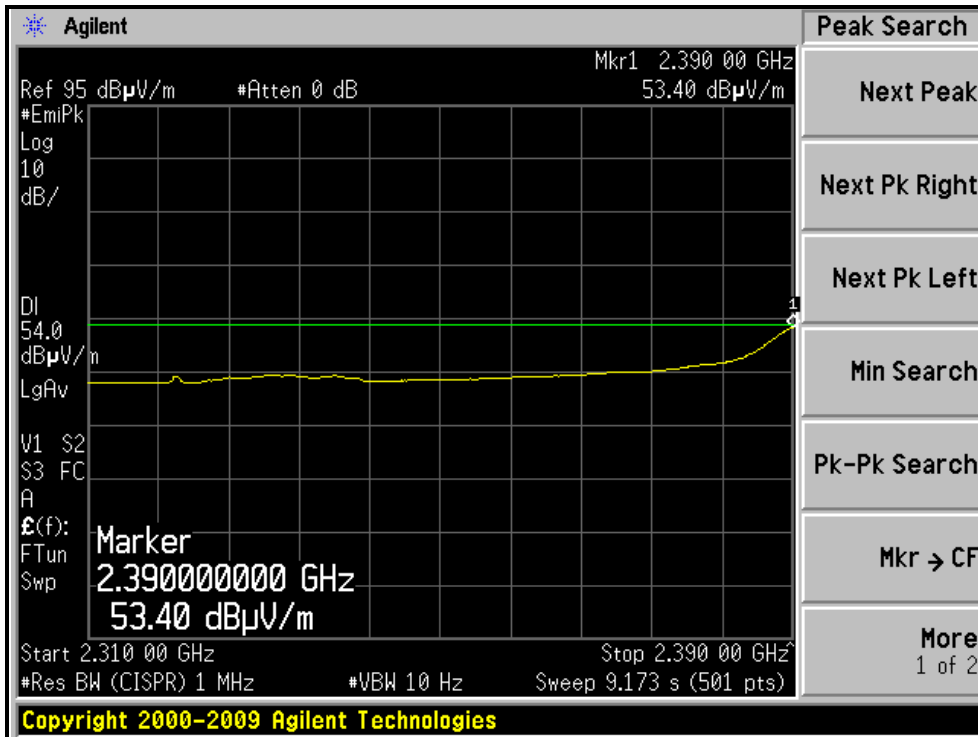
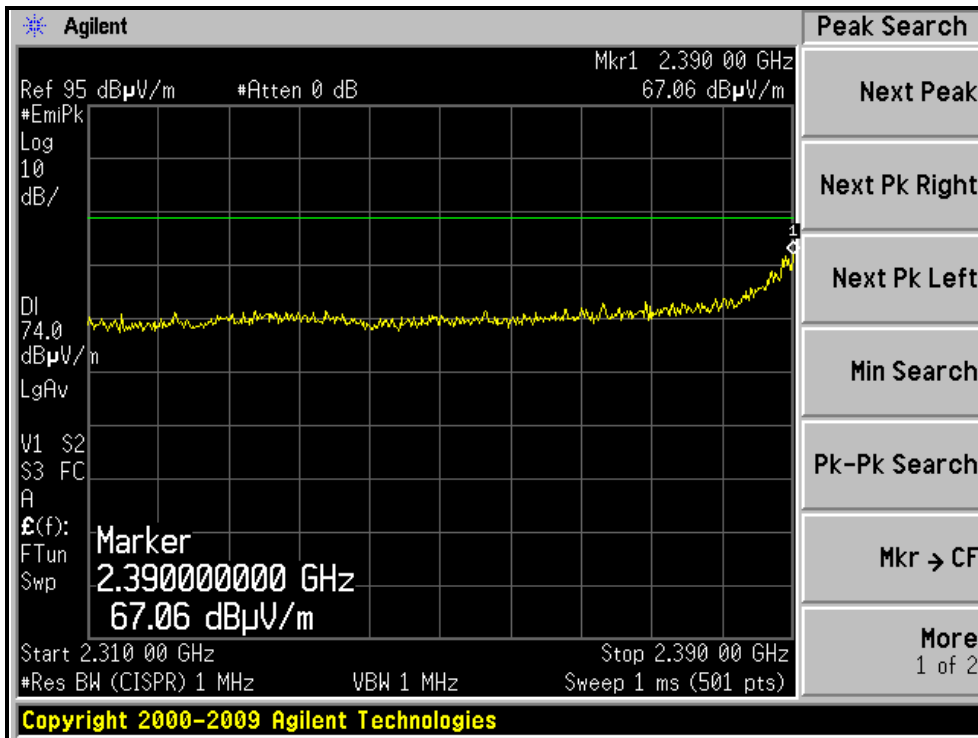



A D T

RESTRICTED BANDEDGE (802.11n (20MHz) MODE,CH1, VERTICAL)

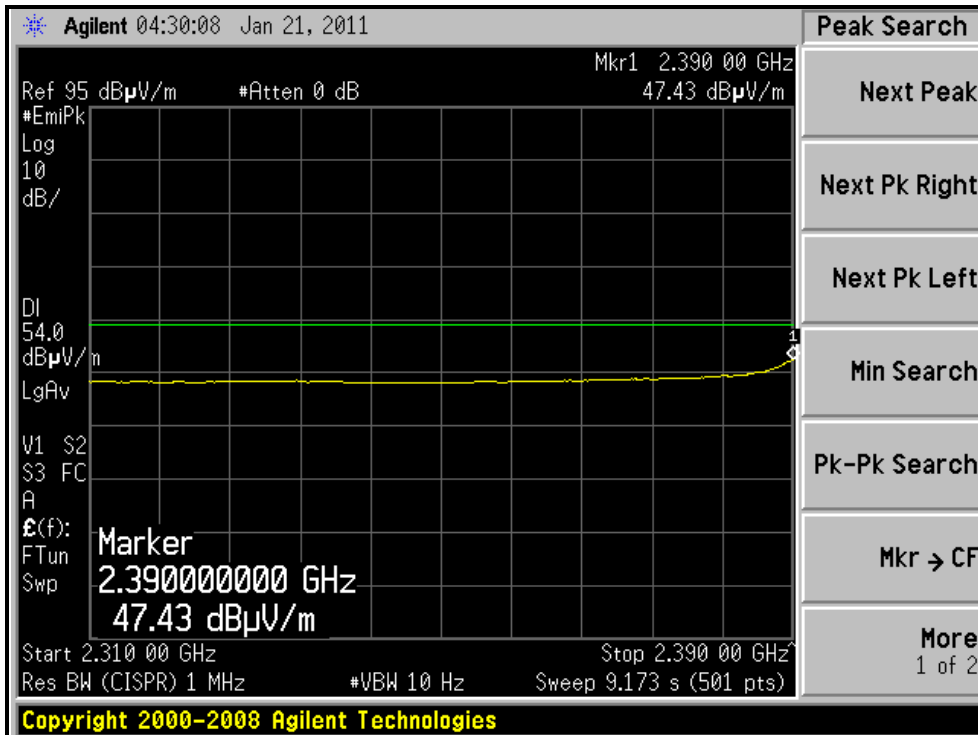
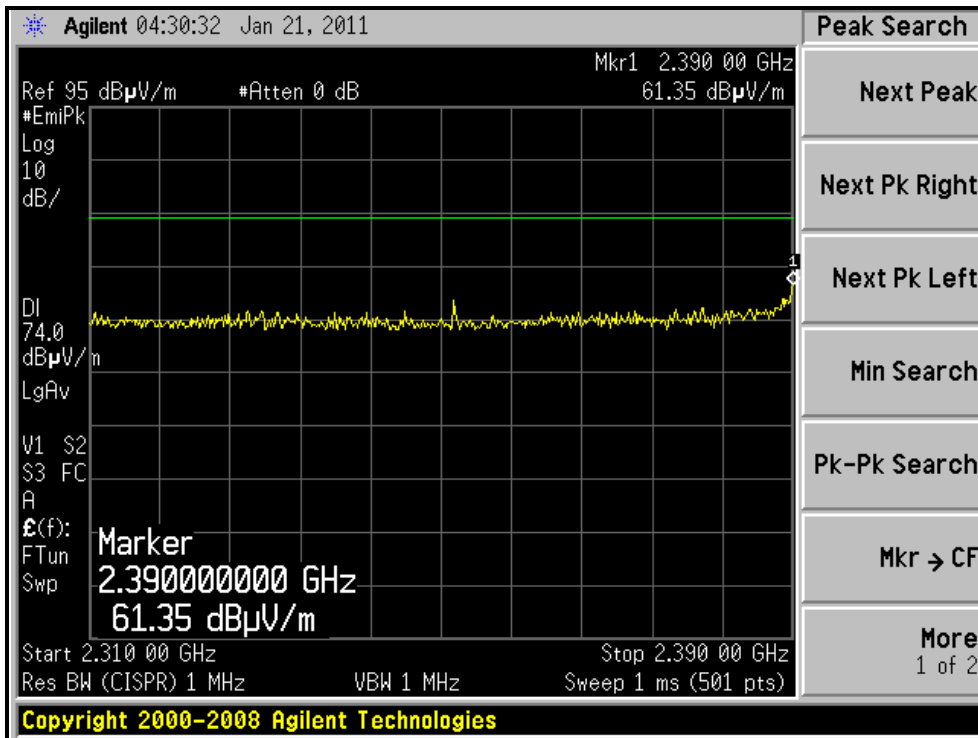

RESTRICTED BANDEDGE (802.11n (20MHz) MODE,CH11, HORIZONTAL)

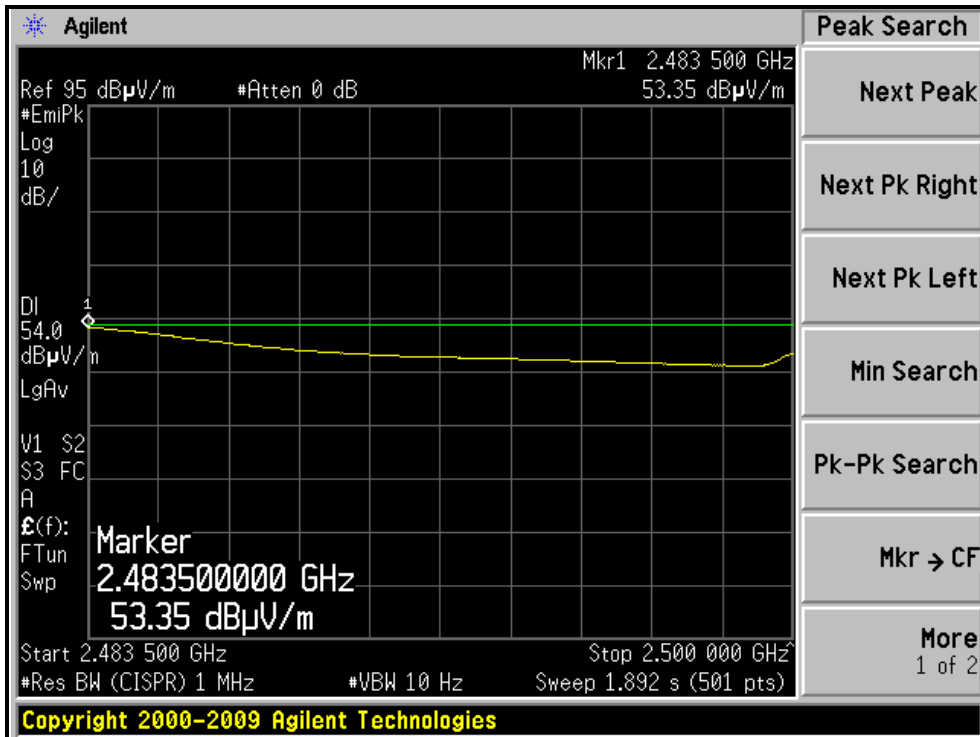
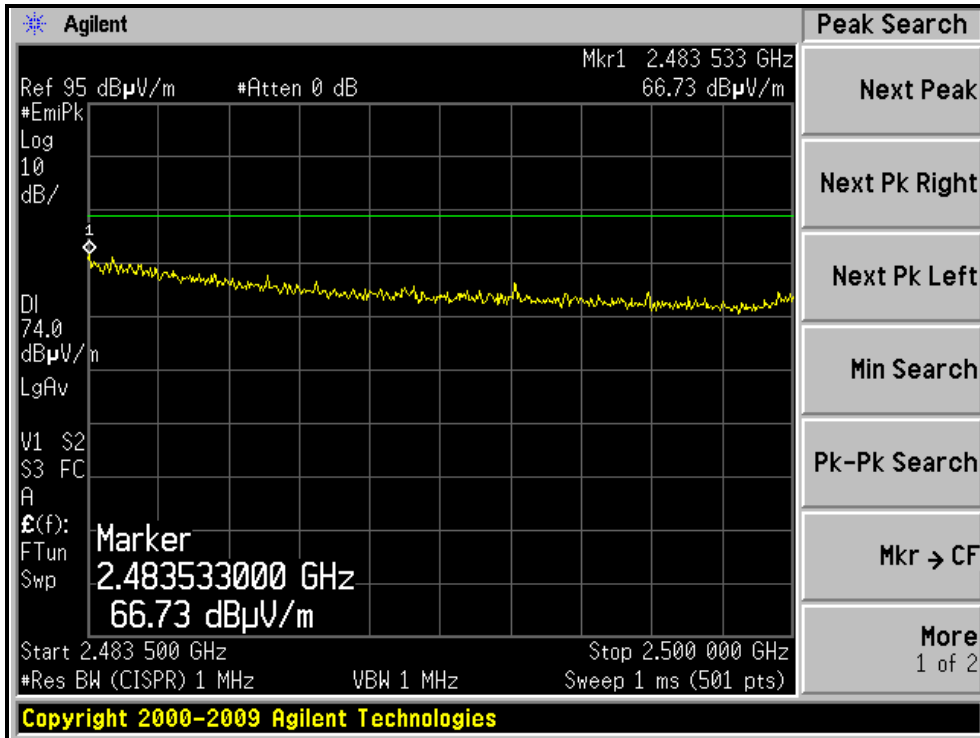



A D T

RESTRICTED BANDEDGE (802.11n (20MHz) MODE,CH11, VERTICAL)

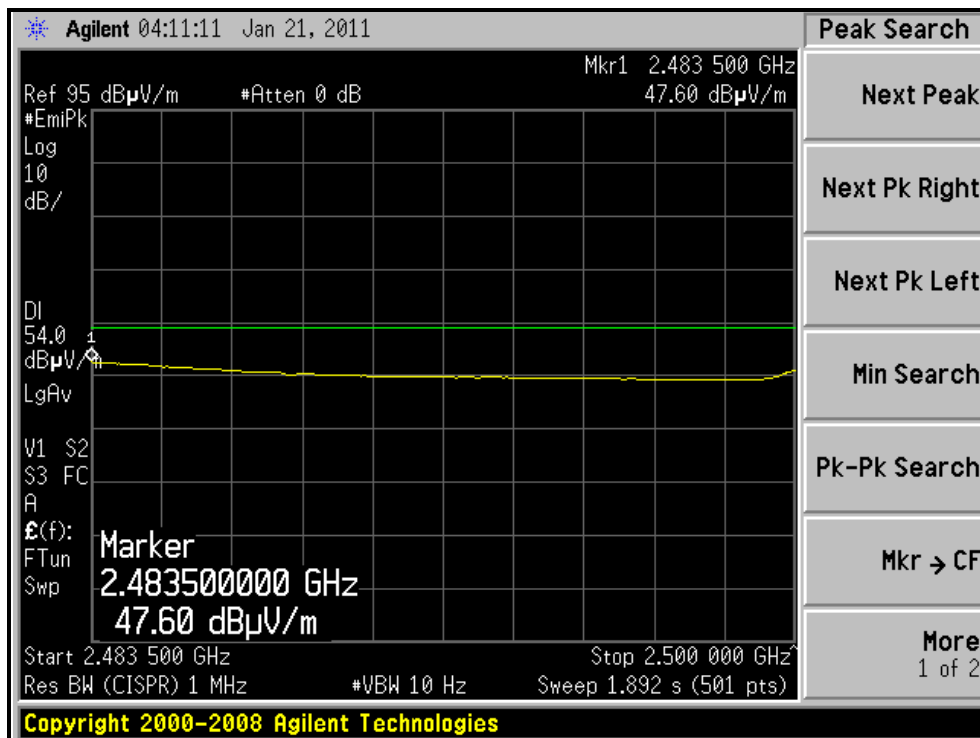
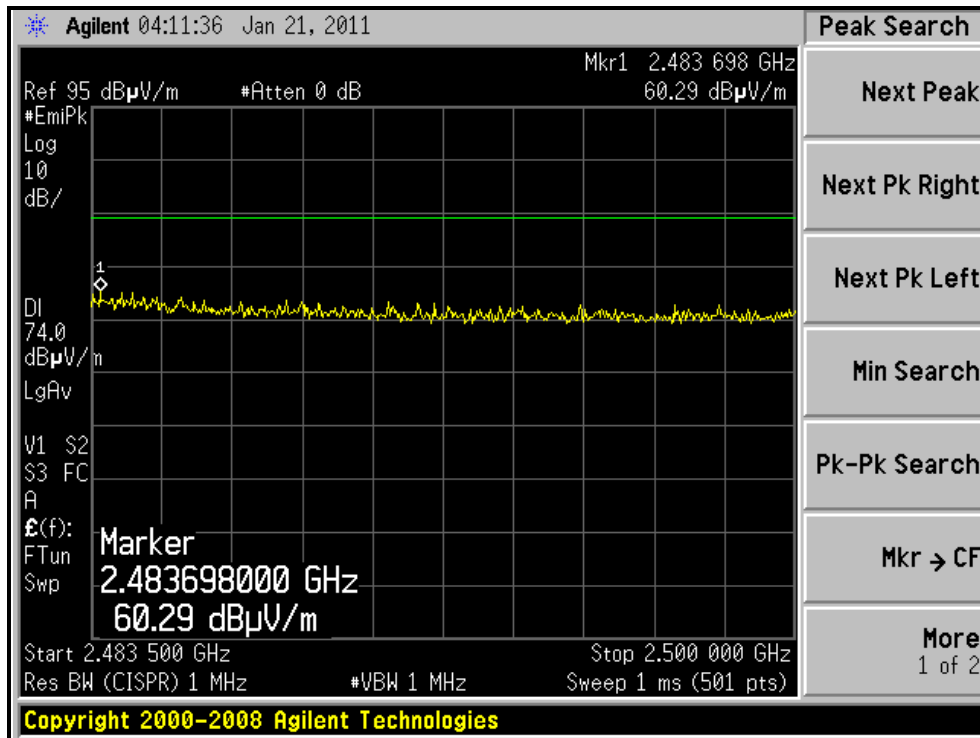



A D T

802.11n (40MHz) OFDM MODULATION

EUT TEST CONDITION		MEASUREMENT DETAIL	
CHANNEL	Channel 3	FREQUENCY RANGE	1 ~ 25GHz
INPUT POWER	120Vac, 60 Hz	DETECTOR FUNCTION	Peak (PK) Average (AV)
ENVIRONMENTAL CONDITIONS	23deg. C, 71%RH 1023 hPa	TESTED BY	Rex Huang

ANTENNA POLARITY & TEST DISTANCE: HORIZONTAL AT 3 M

NO.	FREQ. (MHz)	EMISSION LEVEL (dBuV/m)	LIMIT (dBuV/m)	MARGIN (dB)	ANTENNA HEIGHT (m)	TABLE ANGLE (Degree)	RAW VALUE (dBuV)	CORRECTION FACTOR (dB/m)
1	2389.50	68.7 PK	74.0	-5.3	1.00 H	294	36.82	31.88
2	2389.50	53.1 AV	54.0	-0.9	1.00 H	294	21.22	31.88
3	*2422.00	105.6 PK			1.00 H	294	73.62	31.98
4	*2422.00	94.5 AV			1.00 H	294	62.52	31.98
5	4844.00	48.4 PK	74.0	-25.6	1.05 H	59	7.12	41.28
6	4844.00	34.1 AV	54.0	-19.9	1.05 H	59	-7.18	41.28
7	7266.00	52.9 PK	74.0	-21.1	1.10 H	254	7.35	45.55
8	7266.00	41.4 AV	54.0	-12.6	1.10 H	254	-4.15	45.55

ANTENNA POLARITY & TEST DISTANCE: VERTICAL AT 3 M

NO.	FREQ. (MHz)	EMISSION LEVEL (dBuV/m)	LIMIT (dBuV/m)	MARGIN (dB)	ANTENNA HEIGHT (m)	TABLE ANGLE (Degree)	RAW VALUE (dBuV)	CORRECTION FACTOR (dB/m)
1	2390.00	64.0 PK	74.0	-10.0	1.19 V	33	32.12	31.88
2	2390.00	49.0 AV	54.0	-5.0	1.19 V	33	17.12	31.88
3	*2422.00	98.5 PK			1.19 V	33	66.52	31.98
4	*2422.00	86.2 AV			1.19 V	33	54.22	31.98
5	4844.00	50.1 PK	74.0	-23.9	1.03 V	235	8.82	41.28
6	4844.00	36.4 AV	54.0	-17.6	1.03 V	235	-4.88	41.28
7	7266.00	53.1 PK	74.0	-20.9	1.12 V	275	7.55	45.55
8	7266.00	41.7 AV	54.0	-12.3	1.12 V	275	-3.85	45.55

- REMARKS:**
1. Emission level (dBuV/m) = Raw Value (dBuV) + Correction Factor (dB/m).
 2. Correction Factor (dB/m) = Antenna Factor (dB/m) + Cable Factor (dB).
 3. The other emission levels were very low against the limit.
 4. Margin value = Emission level – Limit value.
 5. “ * “: Fundamental frequency.



A D T

EUT TEST CONDITION		MEASUREMENT DETAIL	
CHANNEL	Channel 6	FREQUENCY RANGE	1 ~ 25GHz
INPUT POWER	120Vac, 60 Hz	DETECTOR FUNCTION	Peak (PK) Average (AV)
ENVIRONMENTAL CONDITIONS	23deg. C, 71%RH 1023 hPa	TESTED BY	Rex Huang

ANTENNA POLARITY & TEST DISTANCE: HORIZONTAL AT 3 M

NO.	FREQ. (MHz)	EMISSION LEVEL (dBuV/m)	LIMIT (dBuV/m)	MARGIN (dB)	ANTENNA HEIGHT (m)	TABLE ANGLE (Degree)	RAW VALUE (dBuV)	CORRECTION FACTOR (dB/m)
1	2390.00	70.8 PK	74.0	-3.2	1.00 H	293	38.92	31.88
2	2390.00	52.9 AV	54.0	-1.1	1.00 H	293	21.02	31.88
3	*2437.00	108.3 PK			1.00 H	292	76.26	32.04
4	*2437.00	97.3 AV			1.00 H	292	65.26	32.04
5	2483.50	69.3 PK	74.0	-4.7	1.00 H	292	37.11	32.19
6	2483.50	53.0 AV	54.0	-1.0	1.00 H	292	20.81	32.19
7	4874.00	48.4 PK	74.0	-25.6	1.05 H	53	7.04	41.36
8	4874.00	35.6 AV	54.0	-18.4	1.05 H	53	-5.76	41.36
9	7311.00	54.3 PK	74.0	-19.7	1.09 H	264	8.63	45.67
10	7311.00	42.1 AV	54.0	-11.9	1.09 H	264	-3.57	45.67

ANTENNA POLARITY & TEST DISTANCE: VERTICAL AT 3 M

NO.	FREQ. (MHz)	EMISSION LEVEL (dBuV/m)	LIMIT (dBuV/m)	MARGIN (dB)	ANTENNA HEIGHT (m)	TABLE ANGLE (Degree)	RAW VALUE (dBuV)	CORRECTION FACTOR (dB/m)
1	*2437.00	102.1 PK			1.19 V	27	70.06	32.04
2	*2437.00	98.1 AV			1.19 V	27	66.06	32.04
3	4874.00	51.4 PK	74.0	-22.6	1.00 V	259	10.04	41.36
4	4874.00	37.5 AV	54.0	-16.5	1.00 V	259	-3.86	41.36
5	7311.00	54.1 PK	74.0	-19.9	1.14 V	253	8.43	45.67
6	7311.00	42.5 AV	54.0	-11.5	1.14 V	253	-3.17	45.67

- REMARKS:**
1. Emission level (dBuV/m) = Raw Value (dBuV) + Correction Factor (dB/m).
 2. Correction Factor (dB/m) = Antenna Factor (dB/m) + Cable Factor (dB).
 3. The other emission levels were very low against the limit.
 4. Margin value = Emission level – Limit value.
 5. “ * “: Fundamental frequency.



A D T

EUT TEST CONDITION		MEASUREMENT DETAIL	
CHANNEL	Channel 9	FREQUENCY RANGE	1 ~ 25GHz
INPUT POWER	120Vac, 60 Hz	DETECTOR FUNCTION	Peak (PK) Average (AV)
ENVIRONMENTAL CONDITIONS	23deg. C, 71%RH 1023 hPa	TESTED BY	Rex Huang

ANTENNA POLARITY & TEST DISTANCE: HORIZONTAL AT 3 M

NO.	FREQ. (MHz)	EMISSION LEVEL (dBuV/m)	LIMIT (dBuV/m)	MARGIN (dB)	ANTENNA HEIGHT (m)	TABLE ANGLE (Degree)	RAW VALUE (dBuV)	CORRECTION FACTOR (dB/m)
1	*2452.00	104.8 PK			1.00 H	293	72.71	32.09
2	*2452.00	94.2 AV			1.00 H	293	62.11	32.09
3	2483.50	67.6 PK	74.0	-6.4	1.00 H	293	35.41	32.19
4	2483.50	53.4 AV	54.0	-0.6	1.00 H	293	21.21	32.19
5	4904.00	48.7 PK	74.0	-25.3	1.06 H	63	7.26	41.44
6	4904.00	34.5 AV	54.0	-19.5	1.06 H	63	-6.94	41.44
7	7356.00	54.0 PK	74.0	-20.0	1.13 H	249	8.19	45.81
8	7356.00	42.1 AV	54.0	-11.9	1.13 H	249	-3.71	45.81

ANTENNA POLARITY & TEST DISTANCE: VERTICAL AT 3 M

NO.	FREQ. (MHz)	EMISSION LEVEL (dBuV/m)	LIMIT (dBuV/m)	MARGIN (dB)	ANTENNA HEIGHT (m)	TABLE ANGLE (Degree)	RAW VALUE (dBuV)	CORRECTION FACTOR (dB/m)
1	*2452.00	97.7 PK			1.12 V	26	65.61	32.09
2	*2452.00	84.8 AV			1.12 V	26	52.71	32.09
3	2483.50	60.7 PK	74.0	-13.3	1.12 V	26	28.51	32.19
4	2483.50	47.3 AV	54.0	-6.7	1.12 V	26	15.11	32.19
5	4904.00	50.8 PK	74.0	-23.2	1.00 V	262	9.36	41.44
6	4904.00	36.2 AV	54.0	-17.8	1.00 V	262	-5.24	41.44
7	7356.00	54.2 PK	74.0	-19.8	1.15 V	273	8.39	45.81
8	7356.00	42.2 AV	54.0	-11.8	1.15 V	273	-3.61	45.81

- REMARKS:**
1. Emission level (dBuV/m) = Raw Value (dBuV) + Correction Factor (dB/m).
 2. Correction Factor (dB/m) = Antenna Factor (dB/m) + Cable Factor (dB).
 3. The other emission levels were very low against the limit.
 4. Margin value = Emission level – Limit value.
 5. “ * “: Fundamental frequency.

RESTRICTED BANDEDGE (802.11n (40MHz) MODE,CH3, HORIZONTAL)

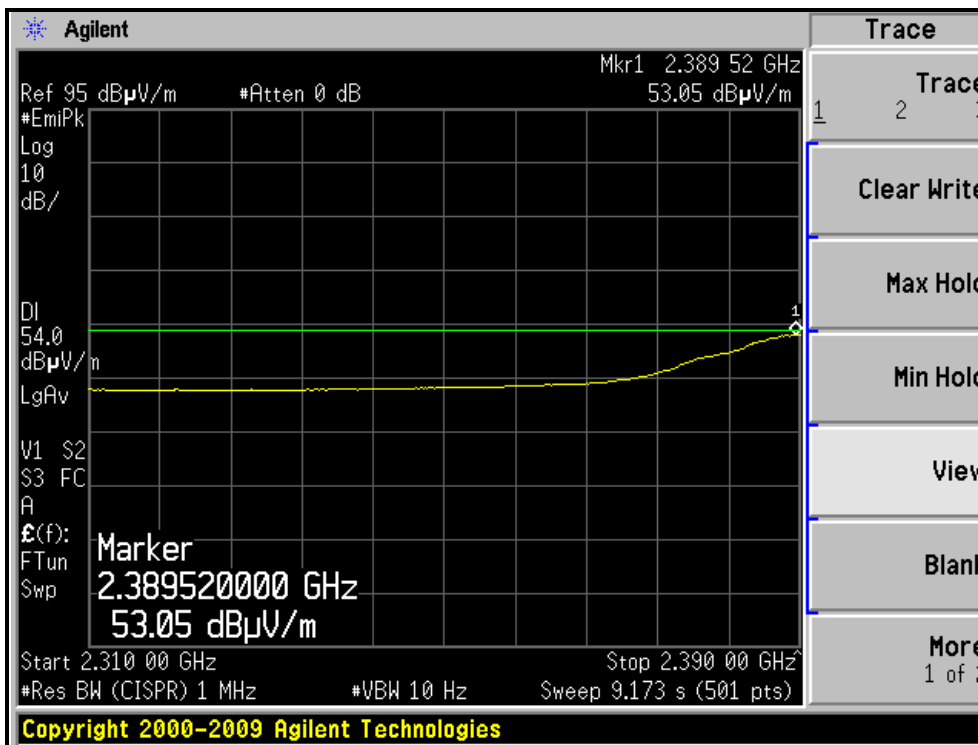
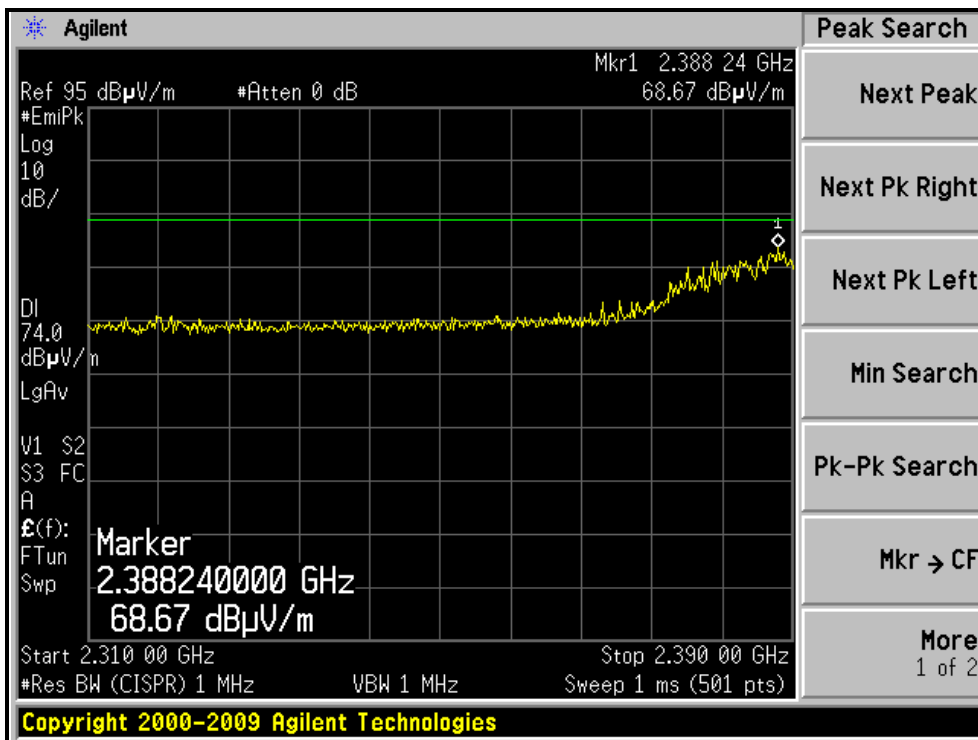



A D T

RESTRICTED BANDEDGE (802.11n (40MHz) MODE,CH3, VERTICAL)

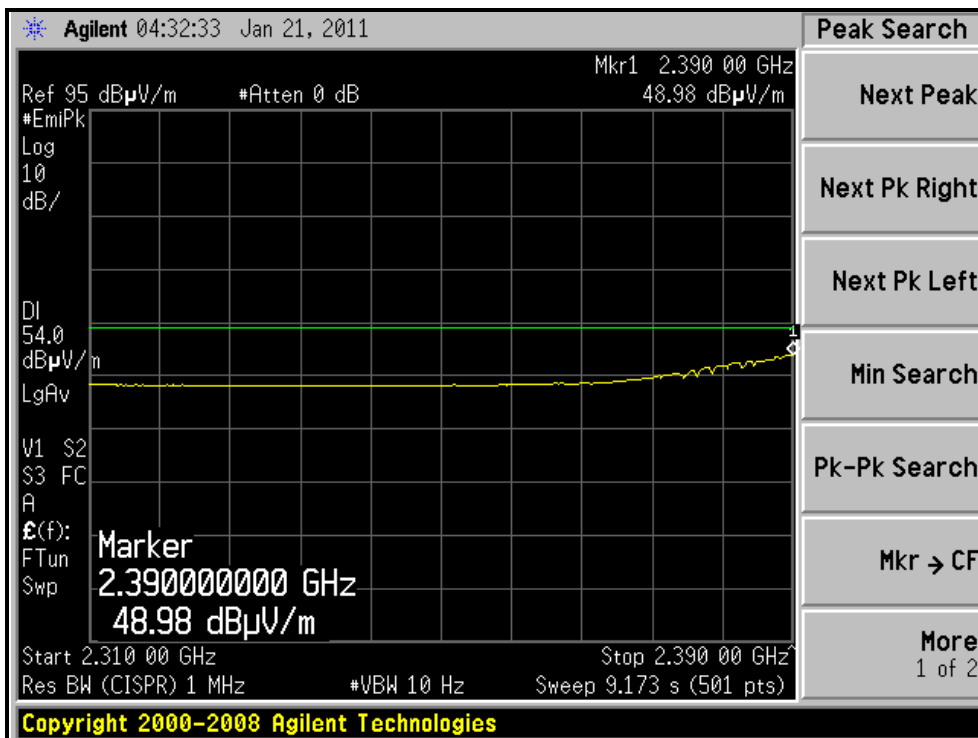
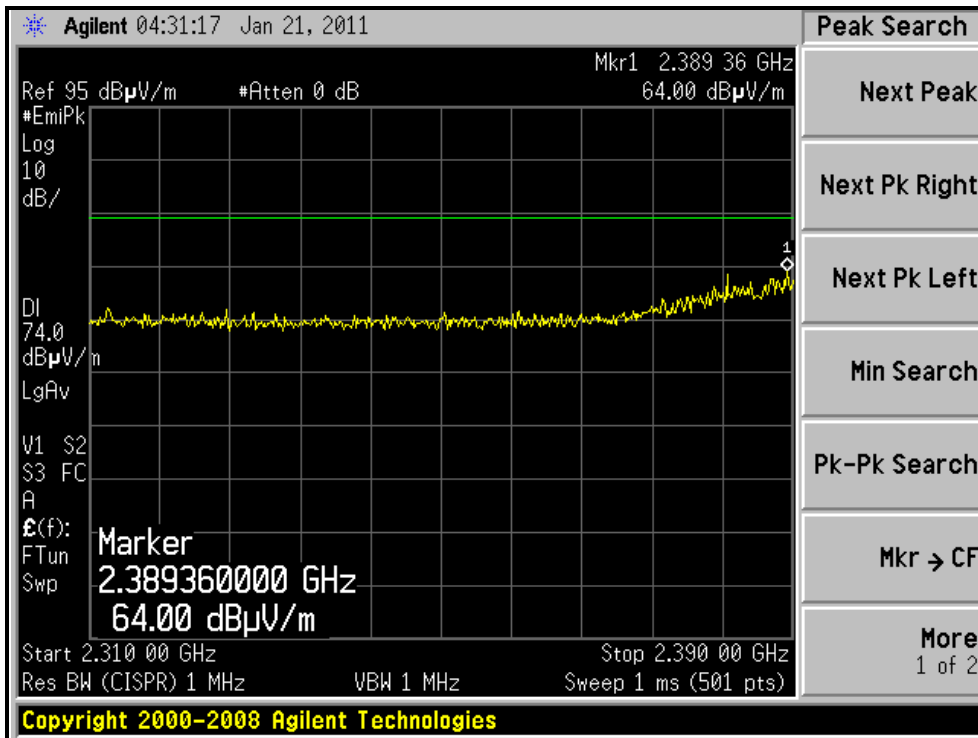



A D T

RESTRICTED BANDEDGE (802.11n (40MHz) MODE,CH9, HORIZONTAL)

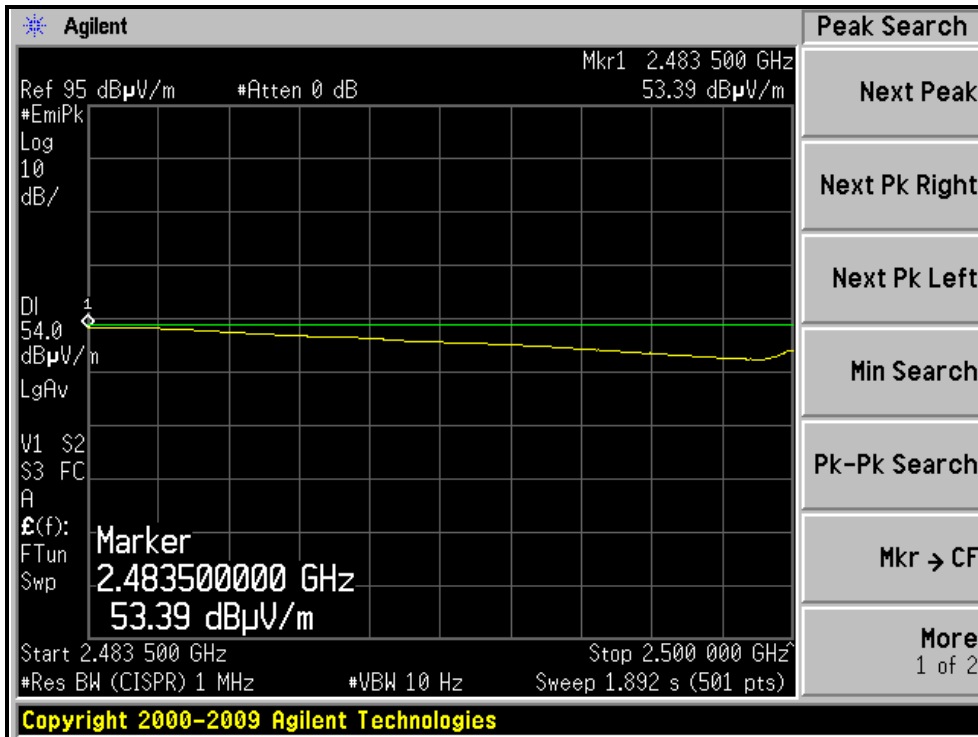
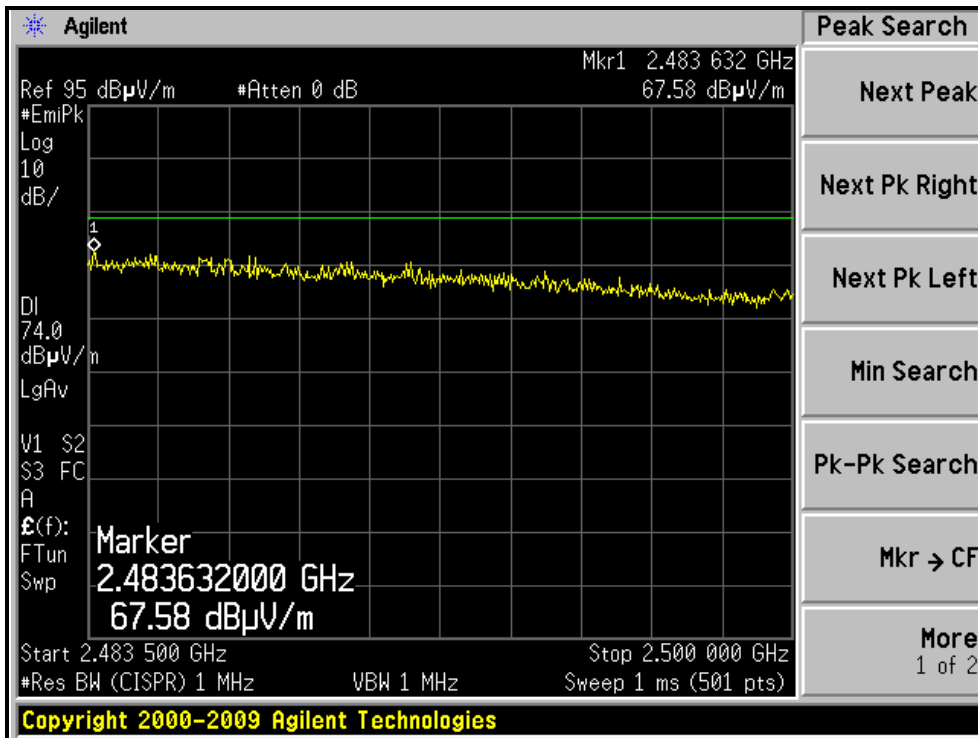



A D T

RESTRICTED BANDEDGE (802.11n (40MHz) MODE,CH9, VERTICAL)

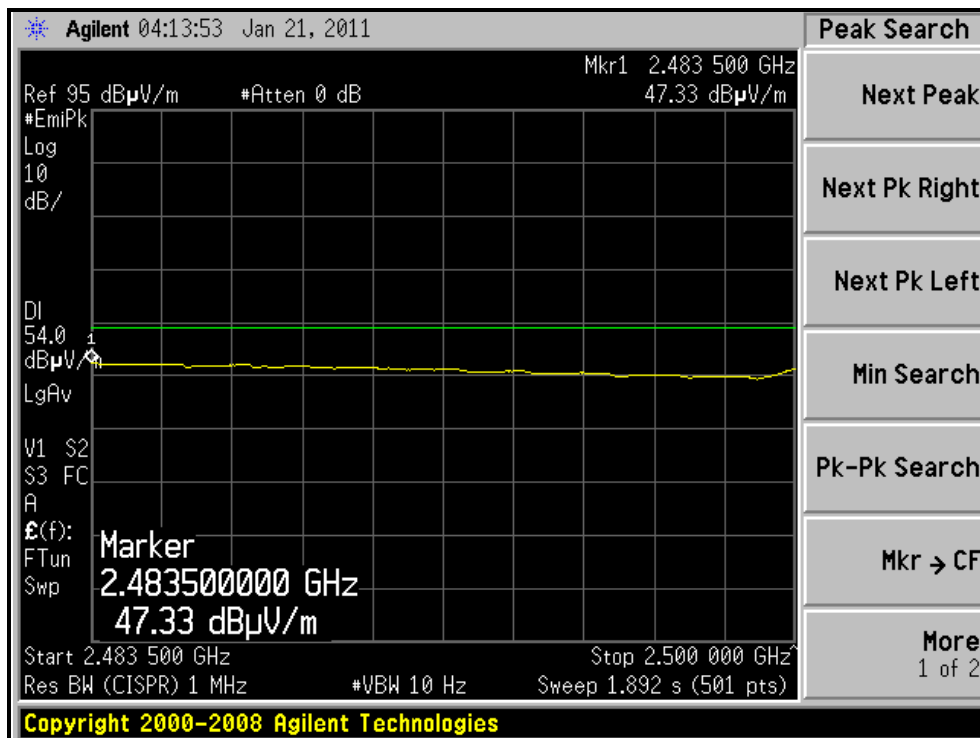
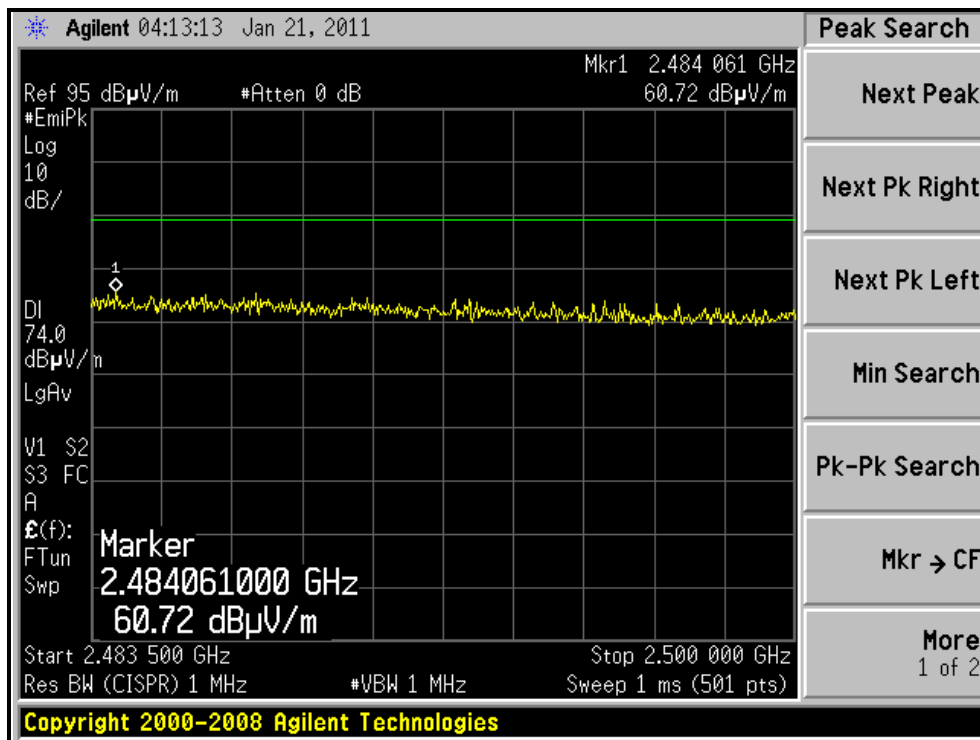

4.3 6dB BANDWIDTH MEASUREMENT

4.3.1 LIMITS OF 6dB BANDWIDTH MEASUREMENT

The minimum of 6dB Bandwidth Measurement is 0.5 MHz.

4.3.2 TEST INSTRUMENTS

DESCRIPTION & MANUFACTURER	MODEL NO.	SERIAL NO.	CALIBRATED DATE	CALIBRATED UNTIL
Spectrum Analyzer	FSP 40	100060	May 17, 2010	May 16, 2011

NOTE: The calibration interval of the above test instruments is 12 months and the calibrations are traceable to NML/ROC and NIST/USA.

4.3.3 TEST PROCEDURE

The transmitter output was connected to the spectrum analyzer through an attenuator. The bandwidth of the fundamental frequency was measured by spectrum analyzer with 100kHz RBW and 100kHz VBW. The 6dB bandwidth is defined as the total spectrum the power of which is higher than peak power minus 6dB.

4.3.4 DEVIATION FROM TEST STANDARD

No deviation

4.3.5 TEST SETUP



4.3.6 EUT OPERATING CONDITIONS

The software provided by client to enable the EUT under transmission condition continuously at lowest, middle and highest channel frequencies individually.

4.3.7 TEST RESULTS

802.11b DSSS MODULATION:

CHANNEL	CHANNEL FREQUENCY (MHz)	6dB BANDWIDTH (MHz)	MINIMUM LIMIT (MHz)	PASS / FAIL
1	2412	8.15	0.5	PASS
6	2437	8.10	0.5	PASS
11	2462	8.19	0.5	PASS

CH11

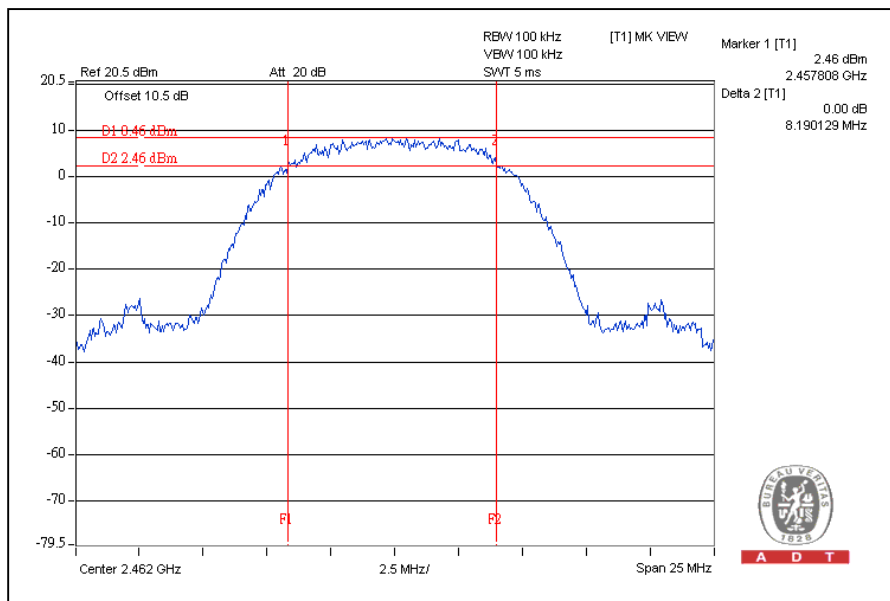

802.11g OFDM MODULATION:

CHANNEL	CHANNEL FREQUENCY (MHz)	6dB BANDWIDTH (MHz)	MINIMUM LIMIT (MHz)	PASS / FAIL
1	2412	14.43	0.5	PASS
6	2437	15.08	0.5	PASS
11	2462	15.14	0.5	PASS

CH11

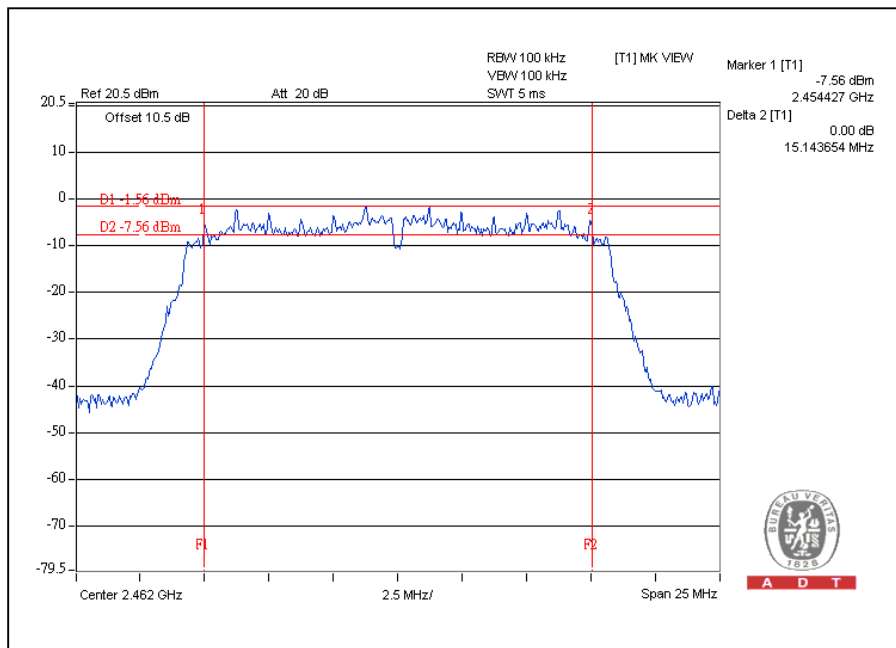



A D T

802.11n (20MHz) OFDM MODULATION:

CHANNEL	CHANNEL FREQUENCY (MHz)	6dB BANDWIDTH (MHz)	MINIMUM LIMIT (MHz)	PASS / FAIL
1	2412	17.32	0.5	PASS
6	2437	15.03	0.5	PASS
11	2462	15.17	0.5	PASS

CH1

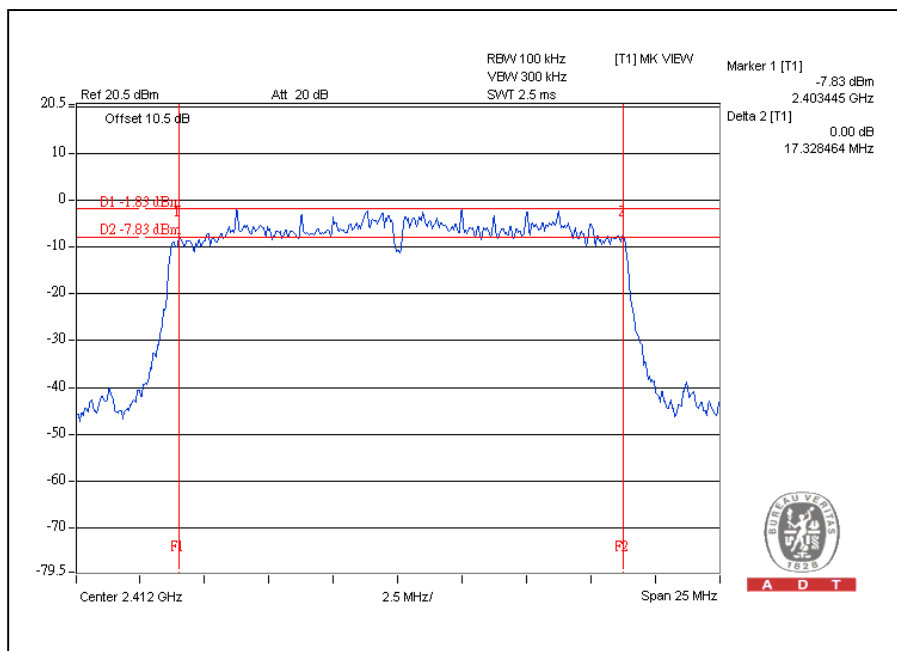



A D T

802.11n (40MHz) OFDM MODULATION:

CHANNEL	CHANNEL FREQUENCY (MHz)	6dB BANDWIDTH (MHz)	MINIMUM LIMIT (MHz)	PASS / FAIL
3	2422	35.56	0.5	PASS
6	2437	35.79	0.5	PASS
9	2452	35.85	0.5	PASS

CH9

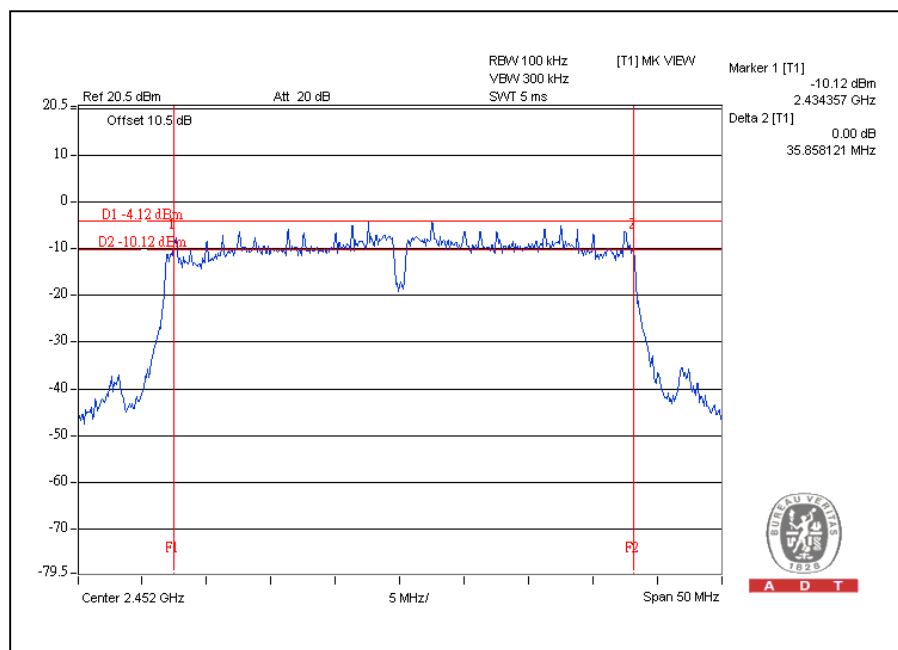

4.4 MAXIMUM PEAK OUTPUT POWER

4.4.1 LIMITS OF MAXIMUM PEAK OUTPUT POWER MEASUREMENT

The Maximum Peak Output Power Measurement is 30dBm.

4.4.2 INSTRUMENTS

DESCRIPTION & MANUFACTURER	MODEL NO.	SERIAL NO.	CALIBRATED DATE	CALIBRATED UNTIL
Peak Power Meter	ML2495A	0824006	May 04, 2010	May 03, 2011
Power Sensor	MA2411B	0738172	May 04, 2010	May 03, 2011

NOTE: The calibration interval of the above test instruments is 12 months and the calibrations are traceable to NML/ROC and NIST/USA.

4.4.3 TEST PROCEDURES

1. The transmitter output was connected to the power meter through an attenuator; the bandwidth of the fundamental frequency was measured with the power meter.
2. Record the power level.

4.4.4 DEVIATION FROM TEST STANDARD

No deviation

4.4.5 TEST SETUP

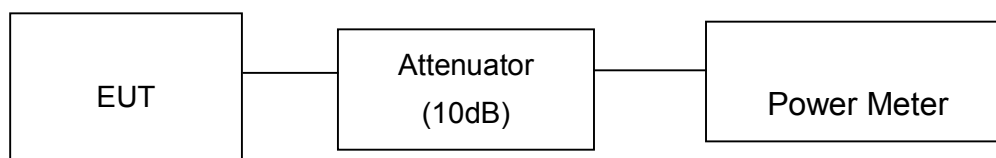

4.4.6 EUT OPERATING CONDITIONS

Same as Item 4.3.6



A D T

4.4.7 TEST RESULTS

802.11b DSSS MODULATION:

CHANNEL	CHANNEL FREQUENCY (MHz)	PEAK POWER OUTPUT (mW)	PEAK POWER OUTPUT (dBm)	PEAK POWER LIMIT (dBm)	PASS / FAIL
1	2412	100.0	20.0	30	PASS
6	2437	162.2	22.1	30	PASS
11	2462	166.0	22.2	30	PASS

802.11g OFDM MODULATION:

CHANNEL	CHANNEL FREQUENCY (MHz)	PEAK POWER OUTPUT (mW)	PEAK POWER OUTPUT (dBm)	PEAK POWER LIMIT (dBm)	PASS / FAIL
1	2412	89.1	19.5	30	PASS
6	2437	371.5	25.7	30	PASS
11	2462	67.6	18.3	30	PASS

802.11n (20MHz) OFDM MODULATION:

CHANNEL	CHANNEL FREQUENCY (MHz)	PEAK POWER OUTPUT (dBm)		TOTAL PEAK POWER (mW)	TOTAL PEAK POWER (dBm)	PEAK POWER LIMIT (dBm)	PASS / FAIL
		CHAIN(0)	CHAIN(1)				
1	2412	19.6	21.6	235.7	23.7	30	PASS
6	2437	24.9	24.9	618.1	27.9	30	PASS
11	2462	21.3	19.7	228.2	23.6	30	PASS



A D T

802.11n (40MHz) OFDM MODULATION:

CHANNEL	CHANNEL FREQUENCY (MHz)	PEAK POWER OUTPUT (dBm)		TOTAL PEAK POWER (mW)	TOTAL PEAK POWER (dBm)	PEAK POWER LIMIT (dBm)	PASS / FAIL
		CHAIN(0)	CHAIN(1)				
3	2422	18.3	17.1	118.9	20.8	30	PASS
6	2437	21.9	21.4	292.9	24.7	30	PASS
9	2452	17.5	18.0	119.3	20.8	30	PASS

4.5 POWER SPECTRAL DENSITY MEASUREMENT

4.5.1 LIMITS OF POWER SPECTRAL DENSITY MEASUREMENT

The Maximum of Power Spectral Density Measurement is 8dBm.

4.5.2 TEST INSTRUMENTS

DESCRIPTION & MANUFACTURER	MODEL NO.	SERIAL NO.	CALIBRATED DATE	CALIBRATED UNTIL
Spectrum Analyzer	FSP 40	100060	May 17, 2010	May 16, 2011

NOTE: The calibration interval of the above test instruments is 12 months and the calibrations are traceable to NML/ROC and NIST/USA.

4.5.3 TEST PROCEDURE

The transmitter output was connected to the spectrum analyzer through an attenuator, the bandwidth of the fundamental frequency was measured with the spectrum analyzer using 3kHz RBW and 30kHz VBW, set sweep time = span/3kHz. The power spectral density was measured and recorded.

The sweep time is allowed to be longer than span/3kHz for a full response of the mixer in the spectrum analyzer.

4.5.4 DEVIATION FROM TEST STANDARD

No deviation

4.5.5 TEST SETUP

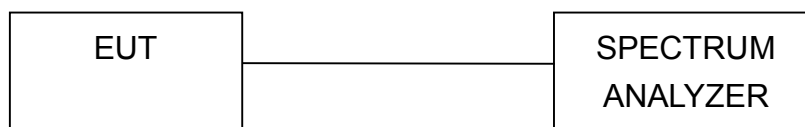

4.5.6 EUT OPERATING CONDITION

Same as Item 4.3.6



A D T

4.5.7 TEST RESULTS

802.11b DSSS MODULATION:

CHANNEL	CHANNEL FREQUENCY (MHz)	RF POWER LEVEL IN 3kHz BW (dBm)	MAXIMUM LIMIT (dBm)	PASS / FAIL
1	2412	-4.2	8	PASS
6	2437	-4.2	8	PASS
11	2462	-3.8	8	PASS

CH11

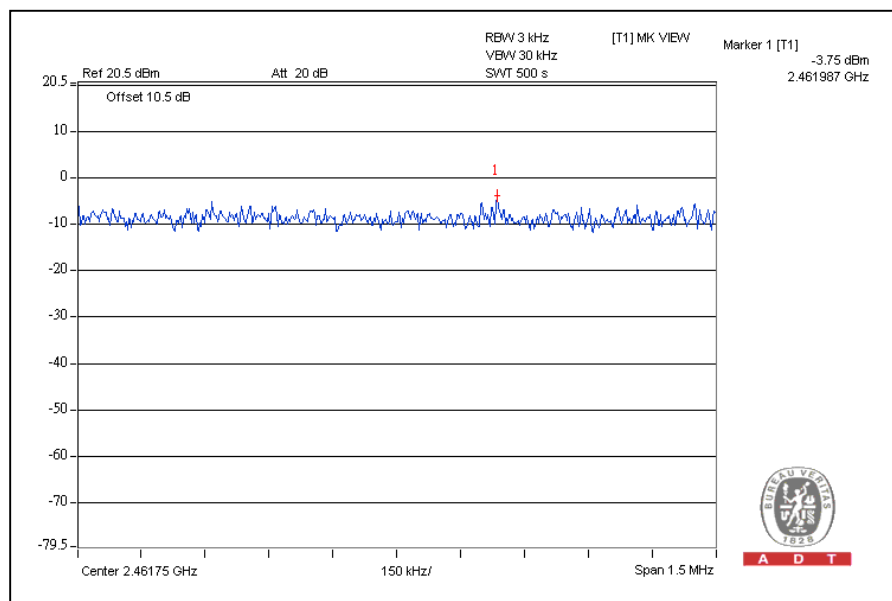



A D T

802.11g OFDM MODULATION:

CHANNEL	CHANNEL FREQUENCY (MHz)	RF POWER LEVEL IN 3kHz BW (dBm)	MAXIMUM LIMIT (dBm)	PASS / FAIL
1	2412	-12.7	8	PASS
6	2437	-4.2	8	PASS
11	2462	-14.4	8	PASS

CH6

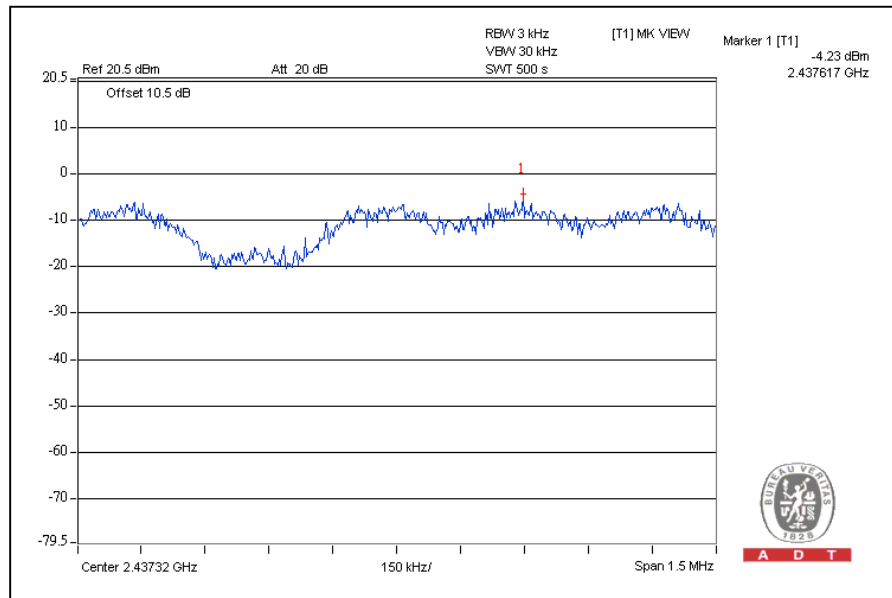



A D T

802.11n (20MHz) OFDM MODULATION:

CHANNEL	CHANNEL FREQUENCY (MHz)	RF POWER LEVEL IN 3kHz BW (dBm)		TOTAL POWER DENSITY (dBm)	MAXIMUM LIMIT (dBm)	PASS / FAIL
		CHAIN(0)	CHAIN(1)			
1	2412	-13.0	-13.1	-10.0	8	PASS
6	2437	-6.1	-6.1	-3.1	8	PASS
11	2462	-15.7	-14.0	-11.8	8	PASS

For Chain(0): CH6

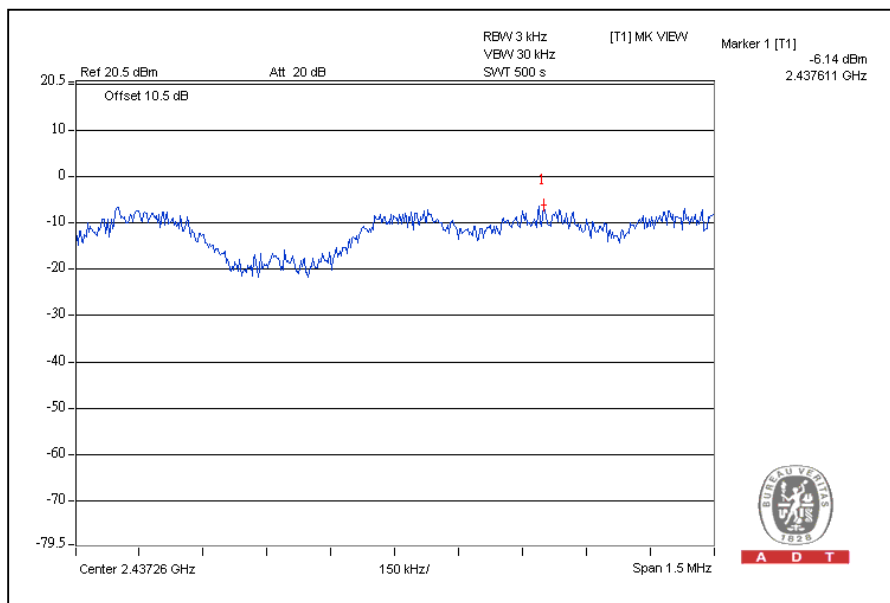



A D T

802.11n (40MHz) OFDM MODULATION:

CHANNEL	CHANNEL FREQUENCY (MHz)	RF POWER LEVEL IN 3kHz BW (dBm)		TOTAL POWER DENSITY (dBm)	MAXIMUM LIMIT (dBm)	PASS / FAIL
		CHAIN(0)	CHAIN(1)			
3	2422	-17.7	-15.4	-13.4	8	PASS
6	2437	-14.9	-13.3	-11.0	8	PASS
9	2452	-18.3	-18.2	-15.2	8	PASS

For Chain (1): CH6

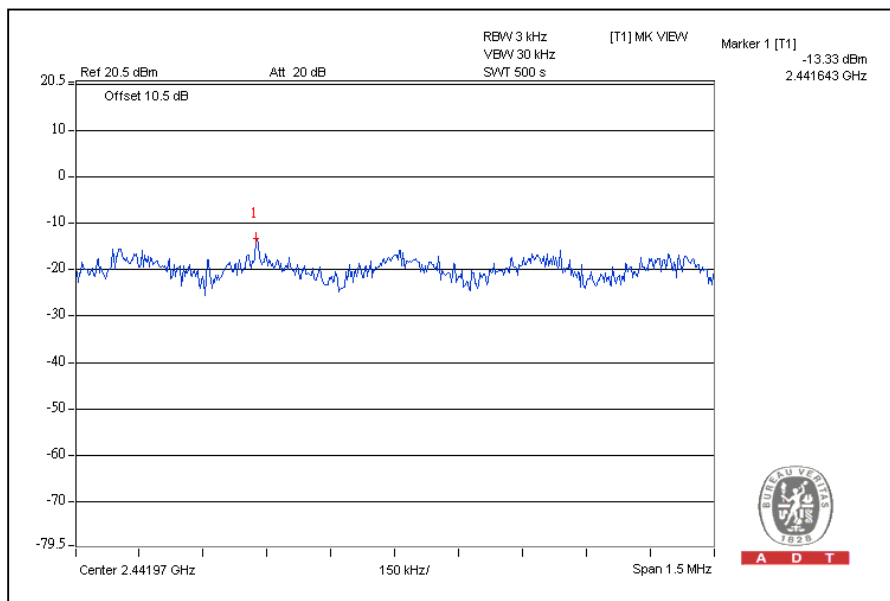

4.6 CONDUCTED OUT-BAND EMISSION MEASUREMENT

4.6.1 LIMITS OF CONDUCTED OUT-BAND EMISSION MEASUREMENT

Below -20dB of the highest emission level of operating band (in 100kHz Resolution Bandwidth).

4.6.2 TEST INSTRUMENTS

DESCRIPTION & MANUFACTURER	MODEL NO.	SERIAL NO.	CALIBRATED DATE	CALIBRATED UNTIL
Spectrum Analyzer	FSP 40	100060	May 17, 2010	May 16, 2011

NOTE: The calibration interval of the above test instruments is 12 months and the calibrations are traceable to NML/ROC and NIST/USA.

4.6.3 TEST PROCEDURE

The transmitter output was connected to the spectrum analyzer via a low loss cable. Set RBW of spectrum analyzer to 100kHz and VBW of spectrum analyzer to 300kHz with suitable frequency span including 100MHz or 200MHz bandwidth from band edge. The band edges was measured and recorded.

The spectrum plots (RBW = 100kHz, VBW = 300kHz) are attached on the following pages.

4.6.4 DEVIATION FROM TEST STANDARD

No deviation

4.6.5 EUT OPERATING CONDITION

Same as Item 4.3.6

4.6.6 TEST RESULTS

The spectrum plots are attached on the following images. D1 line indicates the highest level, and D2 line indicates the 20dB offset below D1. It shows compliance with the requirement in part 15.247(d).



A D T

802.11b DSSS MODULATION:

CH1

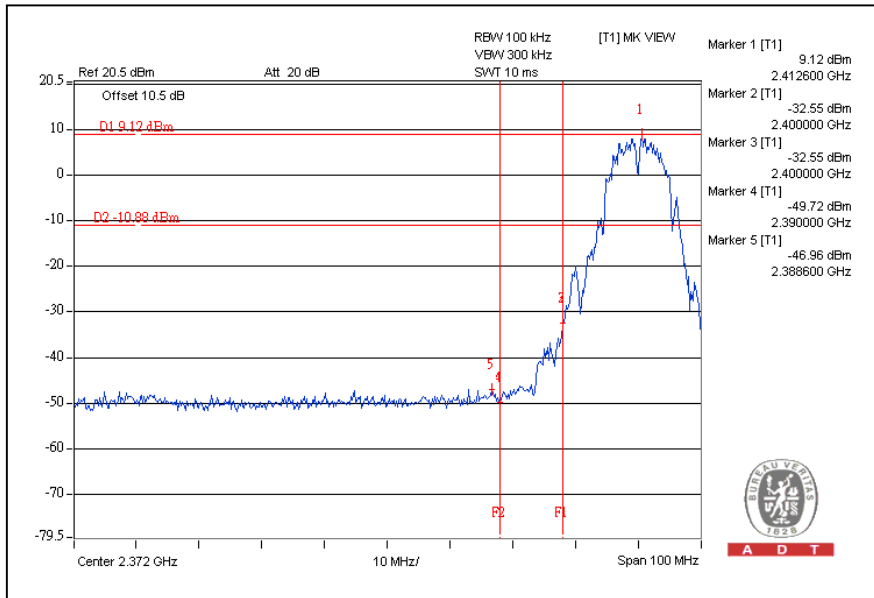

CH11

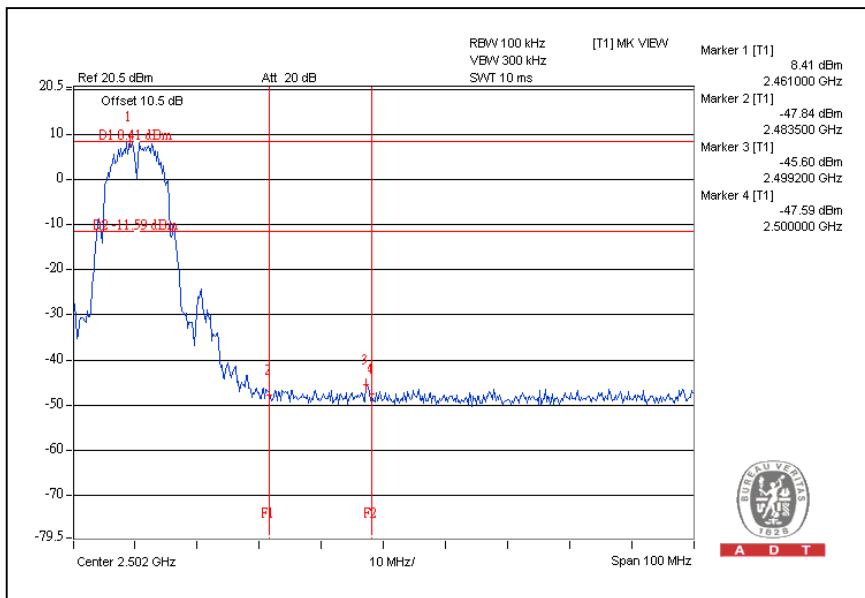



A D T

CH1

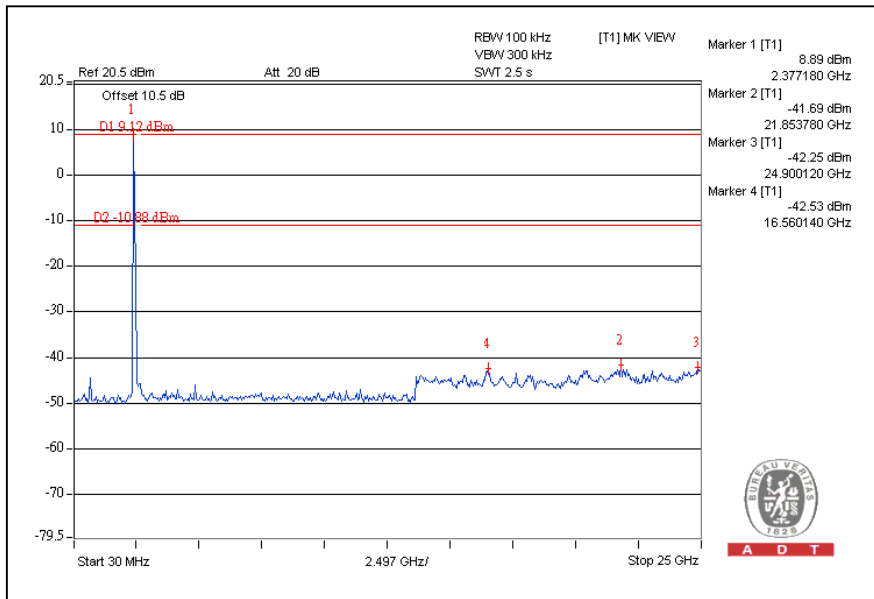

CH11

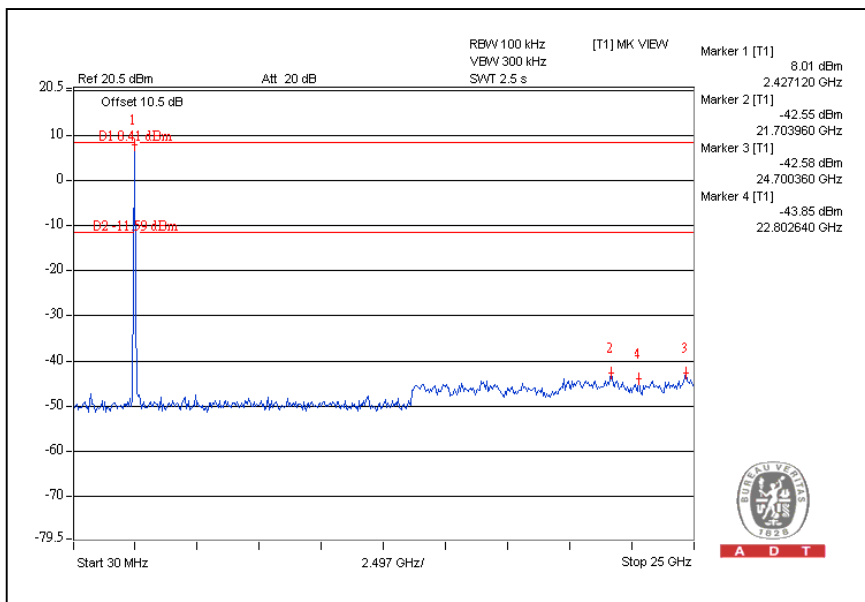



A D T

802.11g OFDM MODULATION:

CH1

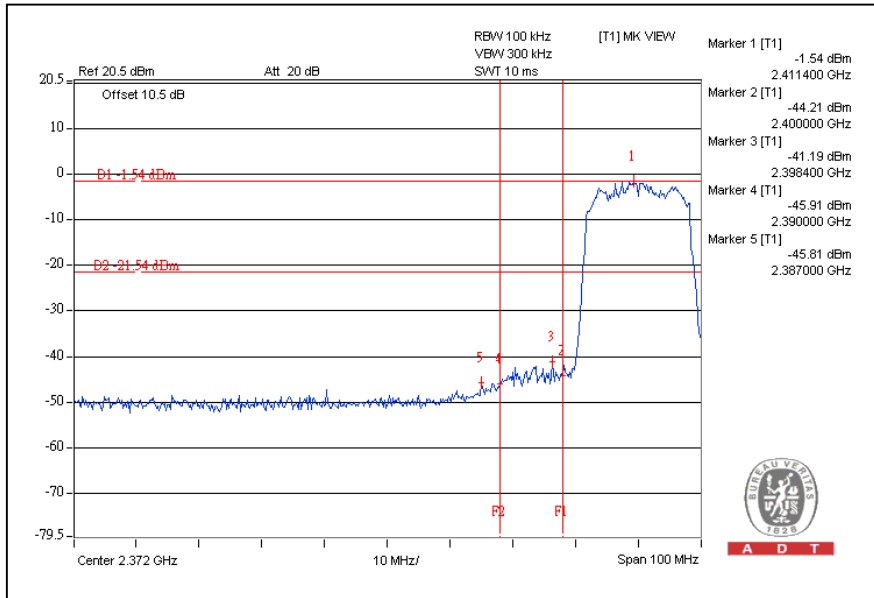

CH11

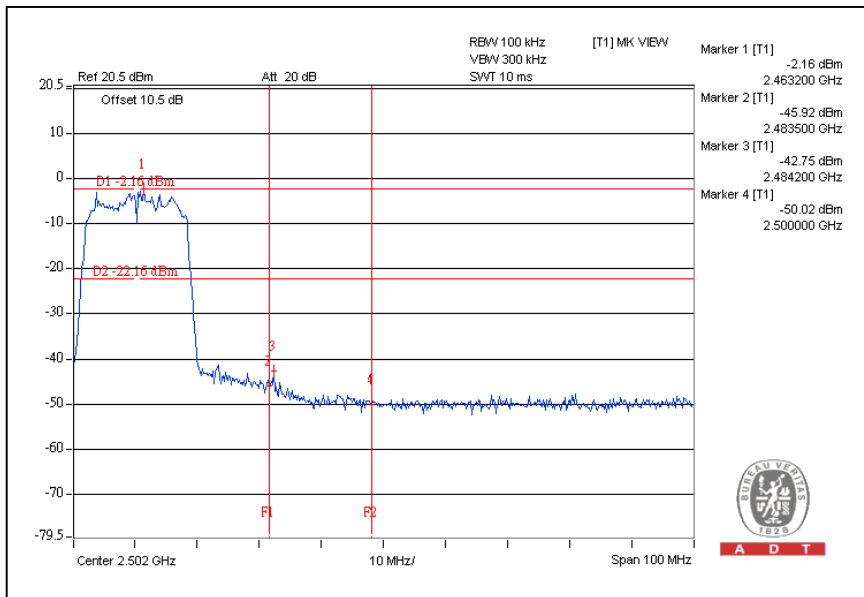



A D T

CH1

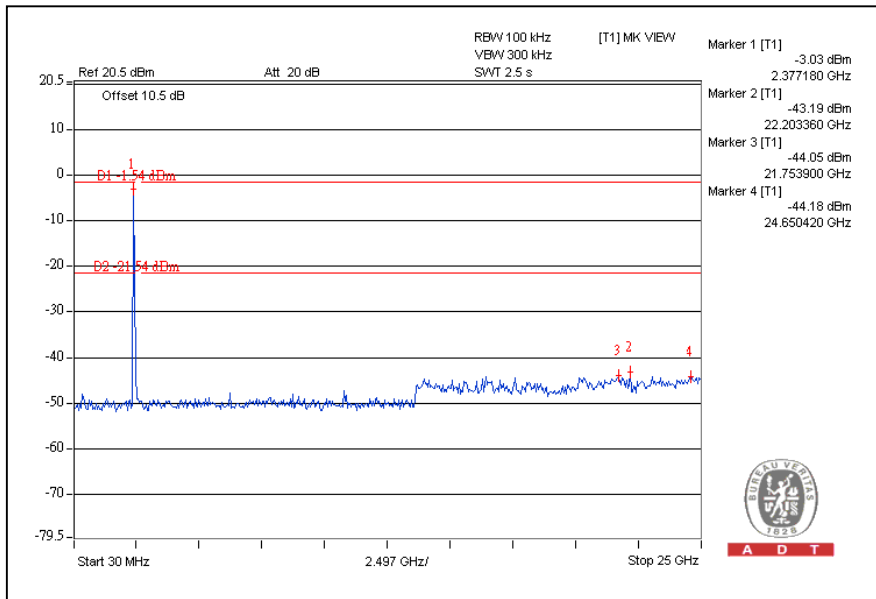

CH11

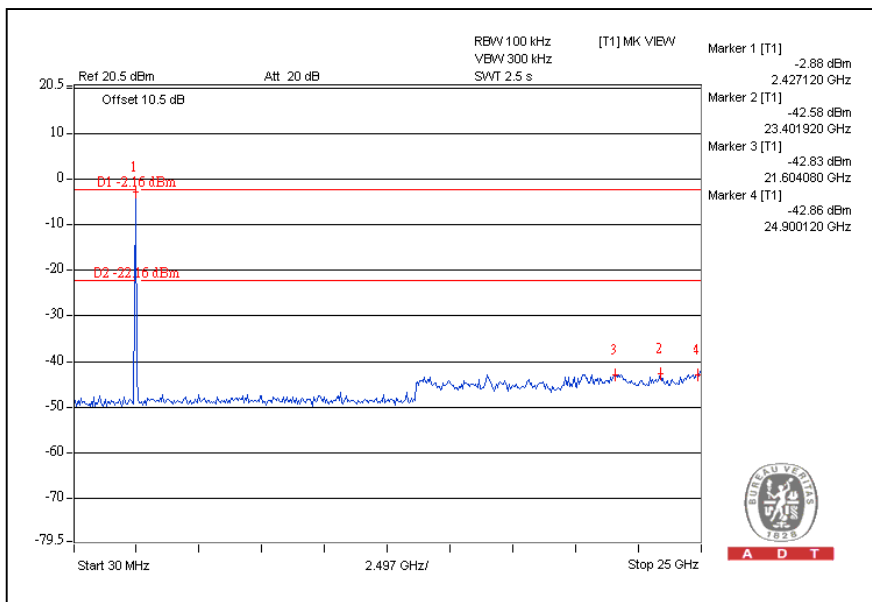



A D T

802.11n (20MHz) OFDM MODULATION:

CH1

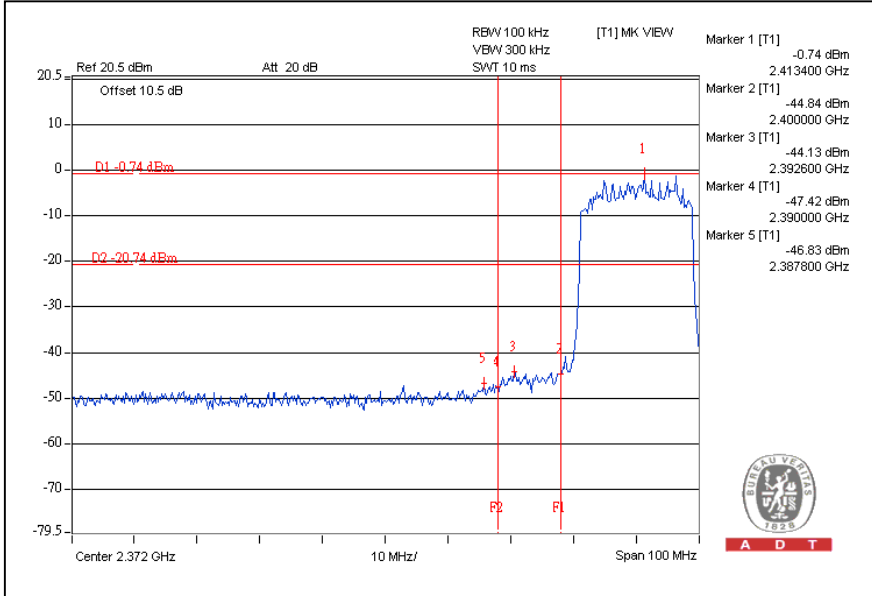

CH11

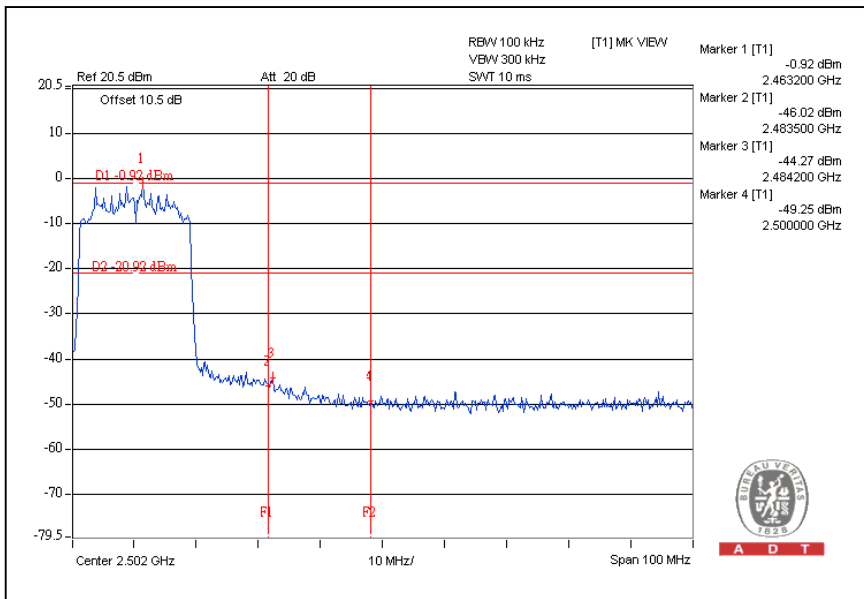



A D T

CH1

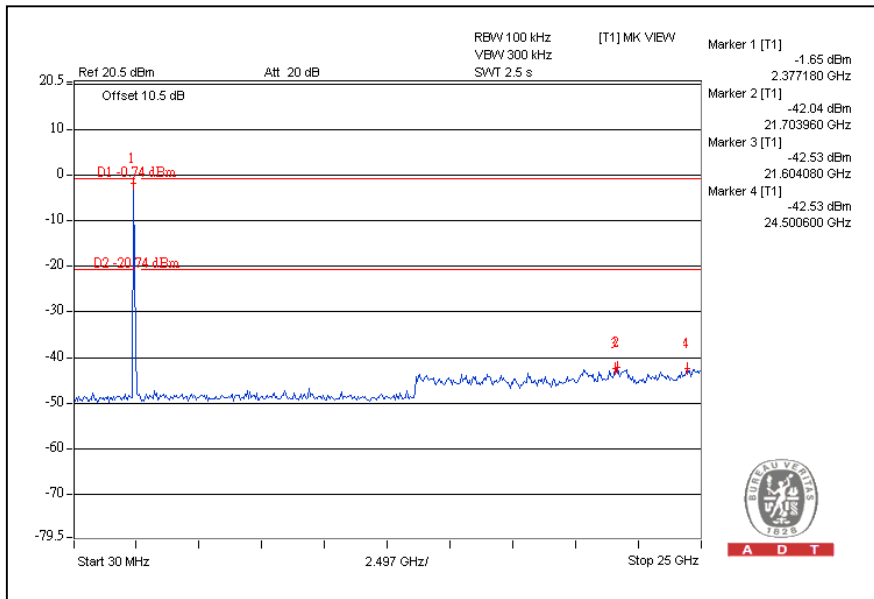

CH11

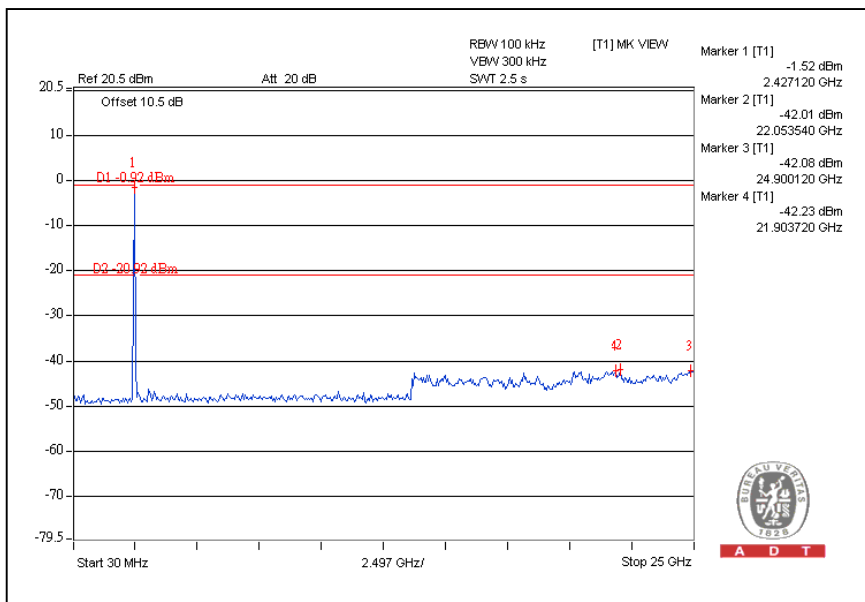

802.11n (40MHz) OFDM MODULATION:

CH3

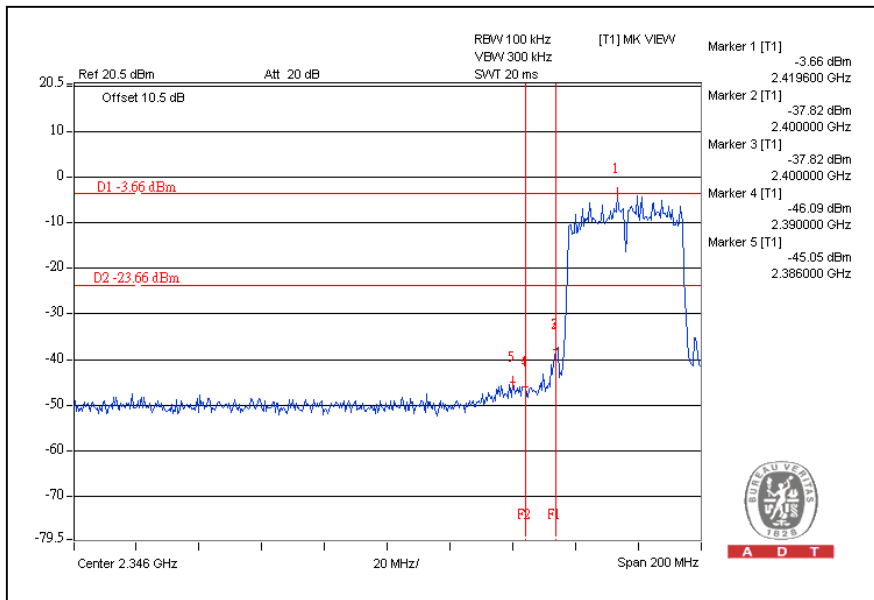

CH9

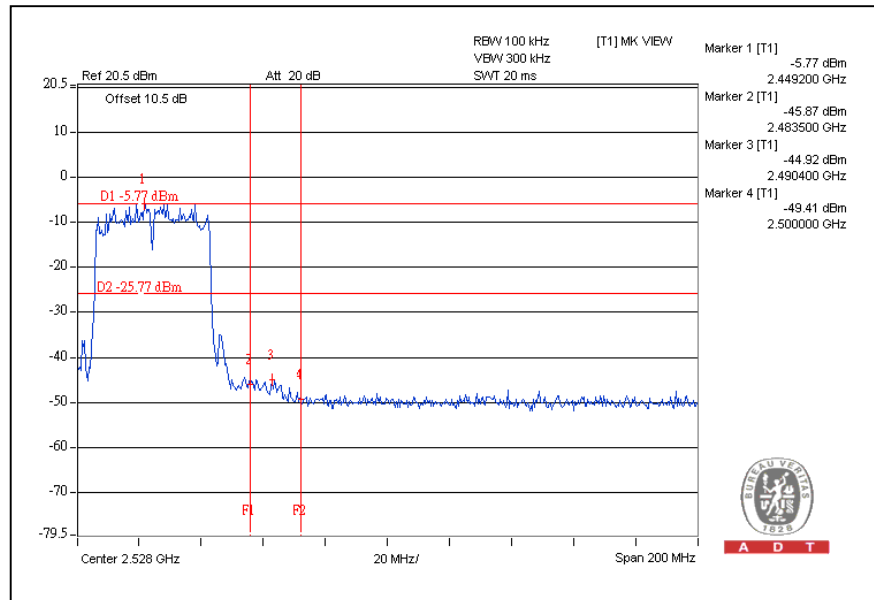



A D T

CH3

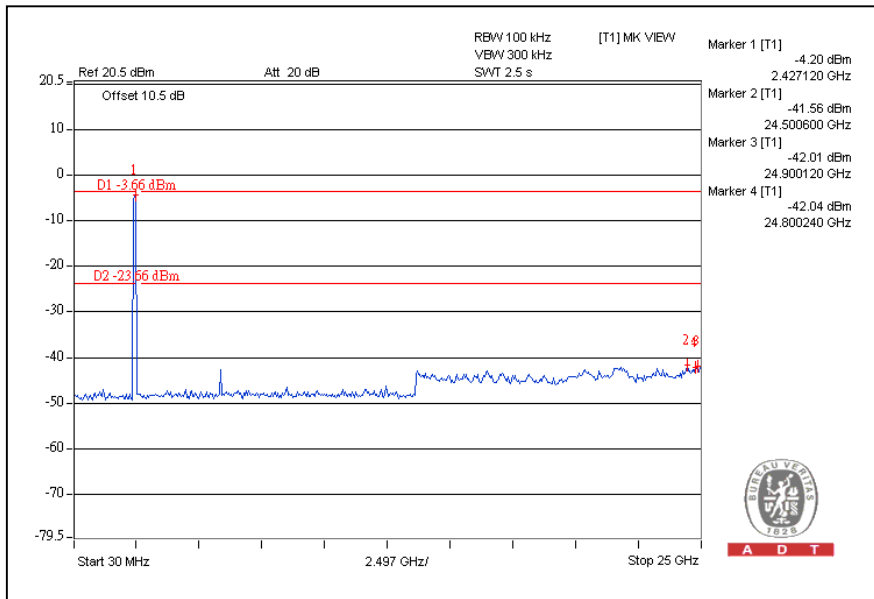

CH9

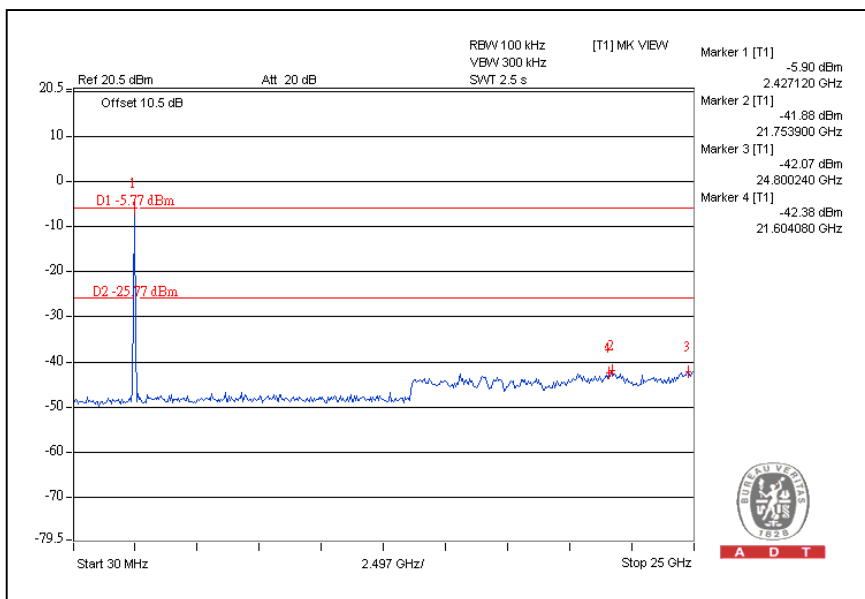



5. INFORMATION ON THE TESTING LABORATORIES

We, Bureau Veritas Consumer Products Services (H.K.) Ltd., Taoyuan Branch, were founded in 1988 to provide our best service in EMC, Radio, Telecom and Safety consultation. Our laboratories are accredited and approved according to ISO/IEC 17025.

Copies of accreditation certificates of our laboratories obtained from approval agencies can be downloaded from our web site: www.adt.com.tw/index.5.phtml. If you have any comments, please feel free to contact us at the following:

Linko EMC/RF Lab:
Tel: 886-2-26052180
Fax: 886-2-26052943

Hsin Chu EMC/RF Lab:
Tel: 886-3-5935343
Fax: 886-3-5935342

Hwa Ya EMC/RF/Safety Telecom Lab:
Tel: 886-3-3183232
Fax: 886-3-3185050

Web Site: www.adt.com.tw

The address and road map of all our labs can be found in our web site also



A D T

6.APPENDIX A - MODIFICATIONS RECORDERS FOR ENGINEERING CHANGES TO THE EUT BY THE LAB

No any modifications are made to the EUT by the lab during the test.

--- END ---