



SPORTON International Inc.

No.8, Lane 724, Bo-ai St., Jhubei City, Hsinchu County 302, Taiwan, R.O.C.
Ph: 886-3-656-9065 / FAX: 886-3-656-9085 / www.sporton.com.tw

FCC RADIO TEST REPORT

Applicant's company	Linksys LLC
Applicant Address	131 Theory Drive, Irvine Ca., 92617
FCC ID	Q87-WUSB6300
Manufacturer's company	Linksys LLC
Manufacturer Address	131 Theory Drive, Irvine Ca., 92617

Product Name	Linksys Dual Band Wireless-AC USB Adapter
Brand Name	Linksys
Model No.	WUSB6300
Test Rule Part(s)	47 CFR FCC Part 15 Subpart E § 15.407
Test Freq. Range	5250 ~ 5350MHz / 5470 ~ 5725MHz
Received Date	Nov. 01, 2012
Final Test Date	Aug. 02, 2013
Submission Type	Class II Change
Operating Mode	Client (without radar detection function)

Statement

Test result included is for the IEEE 802.11n and IEEE 802.11a/ac (5250 ~ 5350MHz / 5470 ~ 5725MHz) of the product.

The test result in this report refers exclusively to the presented test model / sample.

Without written approval of SPORTON International Inc., the test report shall not be reproduced except in full.

The measurements and test results shown in this test report were made in accordance with the procedures and found in compliance with the limit given in ANSI C63.10-2009,

47 CFR FCC Part 15 Subpart E, KDB 789033 D01 v01r03 and KDB 662911 D01 v02.

The test equipment used to perform the test is calibrated and traceable to NML/ROC.



Table of Contents

1. CERTIFICATE OF COMPLIANCE	1
2. SUMMARY OF THE TEST RESULT	2
3. GENERAL INFORMATION	3
3.1. Product Details	3
3.2. Accessories	5
3.3. Table for Filed Antenna	5
3.4. Table for Carrier Frequencies	6
3.5. Table for Product Information	6
3.6. Table for Test Modes	7
3.7. Table for Testing Locations.....	8
3.8. Table for Class II Change	9
3.9. Table for Supporting Units	9
3.10. Table for Parameters of Test Software Setting	10
3.11. EUT Operation during Test.....	10
3.12. Duty Cycle.....	11
3.13. Test Configurations.....	13
4. TEST RESULT	15
4.1. AC Power Line Conducted Emissions Measurement	15
4.2. 26dB Bandwidth & 99% Occupied Bandwidth Measurement.....	20
4.3. Maximum Conducted Output Power Measurement.....	34
4.4. Power Spectral Density Measurement.....	38
4.5. Peak Excursion Measurement	46
4.6. Radiated Emissions Measurement.....	54
4.7. Band Edge Emissions Measurement.....	80
4.8. Frequency Stability Measurement.....	89
4.9. Antenna Requirements	91
5. LIST OF MEASURING EQUIPMENTS	92
6. TEST LOCATION	94
7. MEASUREMENT UNCERTAINTY	95
APPENDIX A. TEST PHOTOS	A1 ~ A5



History of This Test Report

REPORT NO.	VERSION	DESCRIPTION	ISSUED DATE
FR2N0801-03	Rev. 01	Initial issue of report	Aug. 19, 2013



1. CERTIFICATE OF COMPLIANCE

Product Name : Linksys Dual Band Wireless-AC USB Adapter
Brand Name : Linksys
Model No. : WUSB6300
Applicant : Linksys LLC
Test Rule Part(s) : 47 CFR FCC Part 15 Subpart E § 15.407

Sporton International as requested by the applicant to evaluate the EMC performance of the product sample received on Nov. 01, 2012 would like to declare that the tested sample has been evaluated and found to be in compliance with the tested rule parts. The data recorded as well as the test configuration specified is true and accurate for showing the sample's EMC nature.

A handwritten signature in blue ink that reads 'Sam Chen'.

Sam Chen

SPORTON INTERNATIONAL INC.

2. SUMMARY OF THE TEST RESULT

Applied Standard: 47 CFR FCC Part 15 Subpart E				
Part	Rule Section	Description of Test	Result	Under Limit
4.1	15.207	AC Power Line Conducted Emissions	Complies	7.19 dB
4.2	15.407(a)	26dB Spectrum Bandwidth & 99% Occupied Bandwidth	Complies	-
4.3	15.407(a)	Maximum Conducted Output Power	Complies	5.91 dB
4.4	15.407(a)	Power Spectral Density	Complies	4.23 dB
4.5	15.407(a)	Peak Excursion	Complies	3.12 dB
4.6	15.407(b)	Radiated Emissions	Complies	9.40 dB
4.7	15.407(b)	Band Edge Emissions	Complies	1.06 dB
4.8	15.407(g)	Frequency Stability	Complies	-
4.9	15.203	Antenna Requirements	Complies	-

3. GENERAL INFORMATION

3.1. Product Details

IEEE 802.11n / ac

Items	Description
Product Type	WLAN (2TX, 2RX)
Radio Type	Intentional Transceiver
Power Type	From Host System
Modulation	see the below table for IEEE 802.11n/ac
Data Modulation	For 802.11n: OFDM (BPSK / QPSK / 16QAM / 64QAM) For 802.11ac: OFDM (BPSK / QPSK / 16QAM / 64QAM / 256QAM)
Data Rate (Mbps)	see the below table for IEEE 802.11n/ac
Frequency Range	5250 ~ 5350MHz / 5470 ~ 5725MHz
Channel Number	12 for 20MHz bandwidth ; 5 for 40MHz bandwidth 2 for 80MHz bandwidth
Channel Band Width (99%)	Band 2: 802.11ac MCS0/Nss2 (20MHz): 17.92 MHz ; 802.11ac MCS0/Nss2 (40MHz): 36.48 MHz ; 802.11ac MCS0/Nss2 (80MHz): 75.84 MHz Band 3: 802.11ac MCS0/Nss2 (20MHz): 17.92 MHz ; 802.11ac MCS0/Nss2 (40MHz): 36.48 MHz ; 802.11ac MCS0/Nss2 (80MHz): 76.16 MHz
Maximum Conducted Output Power	Band 2: 802.11ac MCS0/Nss2 (20MHz): 17.84 dBm ; 802.11ac MCS0/Nss2 (40MHz): 17.85 dBm ; 802.11ac MCS0/Nss2 (80MHz): 14.41 dBm Band 3: 802.11ac MCS0/Nss2 (20MHz): 18.09 dBm ; 802.11ac MCS0/Nss2 (40MHz): 17.81 dBm ; 802.11ac MCS0/Nss2 (80MHz): 15.86 dBm
Carrier Frequencies	Please refer to section 3.4
Antenna	Please refer to section 3.3

IEEE 802.11a

Items	Description
Product Type	WLAN (1TX, 1RX)
Radio Type	Intentional Transceiver
Power Type	From Host System
Modulation	OFDM for IEEE 802.11a
Data Modulation	OFDM (BPSK / QPSK / 16QAM / 64QAM)
Data Rate (Mbps)	OFDM (6/9/12/18/24/36/48/54)
Frequency Range	5250 ~ 5350MHz / 5470 ~ 5725MHz
Channel Number	12
Channel Band Width (99%)	Band 2: 11a: 16.80 MHz ; Band 3: 11a: 16.96 MHz
Maximum Conducted Output Power	Band 2: 13.72 dBm ; Band 3: 15.83 dBm
Carrier Frequencies	Please refer to section 3.4
Antenna	Please refer to section 3.3

Antenna & Band width

Antenna	Single (TX)			Two (TX)		
	20 MHz	40 MHz	80 MHz	20 MHz	40 MHz	80 MHz
IEEE 802.11a	V	X	X	X	X	X
IEEE 802.11n	X	X	X	V	V	X
IEEE 802.11ac	X	X	X	V	V	V

IEEE 11n / ac Spec.

Protocol	Number of Transmit Chains (NTX)	Data Rate / MCS
802.11n (HT20)	2	MCS0-15
802.11n (HT40)	2	MCS0-15
802.11ac (VHT20)	2	MCS 0-9/Nss1-2
802.11ac (VHT40)	2	MCS 0-9/Nss1-2
802.11ac (VHT80)	2	MCS 0-9/Nss1-2

Note 1: IEEE Std. 802.11n modulation consists of HT20 and HT40 (HT: High Throughput).
Then EUT support HT20 and HT40.

Note 2: IEEE Std. 802.11ac modulation consists of VHT20, VHT40, VHT80 and VHT160 (VHT: Very High Throughput). Then EUT support VHT20, VHT40 and VHT80.

Note 3: Modulation modes consist of below configuration:
11a: IEEE 802.11a, HT20/HT40: IEEE 802.11n, VHT20/VHT40/VHT80: IEEE 802.11ac

3.2. Accessories

N/A

3.3. Table for Filed Antenna

Ant.	Brand	Model Name	Antenna Type	Connector	Gain (dBi)	
					5GHz	
1	SERCOMM	AC-950	Printer Antenna	NA	Band 2	3.99
					Band 3	4.39
2	SERCOMM	AC-950	Printer Antenna	NA	Band 2	3.07
					Band 3	2.94

Note: The EUT has two antennas

For IEEE 802.11a mode (1TX/1RX):

It fixed Chain 2 as transmitting and receiving antenna.

For IEEE 802.11n/ac mode (2TX/2RX):

Chain 1 and Chain 2 could transmit / receive simultaneously.

Chain 1 (Connect to Ant. 1) ←



Chain 2 (Connect to Ant. 2) ←



3.4. Table for Carrier Frequencies

There are three bandwidth systems.

For 20MHz bandwidth systems, use Channel 52, 56, 60, 64, 100, 104, 108, 112, 116, 132, 136, 140.

For 40MHz bandwidth systems, use Channel 54, 62, 102, 110, 134.

For 80MHz bandwidth systems, use Channel 58, 106

Frequency Band	Channel No.	Frequency	Channel No.	Frequency
5250~5350 MHz Band 2	52	5260 MHz	60	5300 MHz
	54	5270 MHz	62	5310 MHz
	56	5280 MHz	64	5320 MHz
	58	5290 MHz	-	-
5470~5725 MHz Band 3	100	5500 MHz	112	5560 MHz
	102	5510 MHz	116	5580 MHz
	104	5520 MHz	132	5660 MHz
	106	5530 MHz	134	5670 MHz
	108	5540 MHz	136	5680 MHz
	110	5550 MHz	140	5700 MHz

3.5. Table for Product Information

Items	Description	
Communication Mode	<input checked="" type="checkbox"/> IP Based (Load Based)	<input type="checkbox"/> Frame Based
TPC Function	<input type="checkbox"/> With TPC	<input checked="" type="checkbox"/> Without TPC
Weather Band (5600~5650MHz)	<input type="checkbox"/> With 5600~5650MHz	<input checked="" type="checkbox"/> Without 5600~5650MHz
Beamforming Function	<input type="checkbox"/> With beamforming	<input checked="" type="checkbox"/> Without beamforming

3.6. Table for Test Modes

Preliminary tests were performed in different data rate to find the worst radiated emission. The data rate shown in the table below is the worst-case rate with respect to the specific test item. Investigation has been done on all the possible configurations for searching the worst cases. The following table is a list of the test modes shown in this test report.

Test Items	Mode		Data Rate	Channel	Chain
AC Power Conducted Emission	CTX		-	-	-
Max. Conducted Output Power	11ac 20MHz	Band 2	MCS0/Nss2	52/60/64	1+2
		Band 3	MCS0/Nss2	100/116/140	1+2
	11ac 40MHz	Band 2	MCS0/Nss2	54/62	1+2
		Band 3	MCS0/Nss2	102/110/134	1+2
	11ac 80MHz	Band 2	MCS0/Nss2	58	1+2
		Band 3	MCS0/Nss2	106	1+2
	11a/BPSK	Band 2	6Mbps	52/60/64	2
		Band 3	6Mbps	100/116/140	2
Power Spectral Density	11ac 20MHz	Band 2	MCS0/Nss2	52/60/64	1+2
		Band 3	MCS0/Nss2	100/116/140	1+2
	11ac 40MHz	Band 2	MCS0/Nss2	54/62	1+2
		Band 3	MCS0/Nss2	102/110/134	1+2
	11ac 80MHz	Band 2	MCS0/Nss2	58	1+2
		Band 3	MCS0/Nss2	106	1+2
	11a/BPSK	Band 2	6Mbps	52/60/64	2
		Band 3	6Mbps	100/116/140	2
26dB Spectrum Bandwidth 99% Occupied Bandwidth Measurement	11ac 20MHz	Band 2	MCS0/Nss2	52/60/64	1+2
		Band 3	MCS0/Nss2	100/116/140	1+2
	11ac 40MHz	Band 2	MCS0/Nss2	54/62	1+2
		Band 3	MCS0/Nss2	102/110/134	1+2
	11ac 80MHz	Band 2	MCS0/Nss2	58	1+2
		Band 3	MCS0/Nss2	106	1+2
	11a/BPSK	Band 2	6Mbps	52/60/64	2
		Band 3	6Mbps	100/116/140	2
Peak Excursion	11ac 20MHz	Band 2	MCS0/Nss2	52/60/64	1+2
		Band 3	MCS0/Nss2	100/116/140	1+2
	11ac 40MHz	Band 2	MCS0/Nss2	54/62	1+2
		Band 3	MCS0/Nss2	102/110/134	1+2
	11ac 80MHz	Band 2	MCS0/Nss2	58	1+2
		Band 3	MCS0/Nss2	106	1+2
	11a/BPSK	Band 2	6Mbps	52/60/64	2
		Band 3	6Mbps	100/116/140	2

Radiated Emission Below 1GHz	CTX		-	-	-
Radiated Emission Above 1GHz	11ac 20MHz	Band 2	MCS0/Nss2	52/60/64	1+2
		Band 3	MCS0/Nss2	100/116/140	1+2
	11ac 40MHz	Band 2	MCS0/Nss2	54/62	1+2
		Band 3	MCS0/Nss2	102/110/134	1+2
	11ac 80MHz	Band 2	MCS0/Nss2	58	1+2
		Band 3	MCS0/Nss2	106	1+2
	11a/BPSK	Band 2	6Mbps	52/60/64	2
		Band 3	6Mbps	100/116/140	2
Band Edge Emission	11ac 20MHz	Band 2	MCS0/Nss2	52/60/64	1+2
		Band 3	MCS0/Nss2	100/116/140	1+2
	11ac 40MHz	Band 2	MCS0/Nss2	54/62	1+2
		Band 3	MCS0/Nss2	102/110/134	1+2
	11ac 80MHz	Band 2	MCS0/Nss2	58	1+2
		Band 3	MCS0/Nss2	106	1+2
	11a/BPSK	Band 2	6Mbps	52/60/64	2
		Band 3	6Mbps	100/116/140	2
Frequency Stability	Un-modulation		-	60/100	N/A

The following test modes were performed for all tests:

For Radiated Emission test:

Mode 1: Place EUT in X axis

Mode 2: Place EUT in Y axis

Mode 3: Place EUT in Z axis

For test mode 2 is the worst case and it was record in this test report.

3.7. Table for Testing Locations

Test Site No.	Site Category	Location	FCC Reg. No.	IC File No.	VCCI Reg. No
03CH01-CB	SAC	Hsin Chu	262045	IC 4086D	-
CO01-CB	Conduction	Hsin Chu	262045	IC 4086D	-
TH01-CB	OVEN Room	Hsin Chu	-	-	-

Open Area Test Site (OATS); Semi Anechoic Chamber (SAC).

Please refer section 6 for Test Site Address.

3.8. Table for Class II Change

This product is an extension of original one reported under Sporton project number: 2N0801-01

Below is the table for the change of the product with respect to the original one.

Modifications	Performance Checking
1. Adding 5GHz Band 2 and Band 3 (5250~5350 MHz, 5470~5725 MHz) for this device. 2. Adding USB grounding plan for EMC.	1. 26dB Bandwidth & 99% Occupied Bandwidth Measurement 2. Maximum Conducted Output Power Measurement 3. Power Spectral Density Measurement 4. Peak Excursion Measurement 5. Radiated Emissions Measurement above 1GHz 6. Band Edge Emissions Measurement 7. Frequency Stability Measurement

3.9. Table for Supporting Units

Test Site No.: CO01-CB

Support Unit	Brand	Model	FCC ID
Notebook	DELL	1340	E2K4965AGNM

Test Site No.: 03CH01-CB

Support Unit	Brand	Model	FCC ID
Notebook	DELL	D520	E2KWM3945ABG

Test Site No.: TH01-CB

Support Unit	Brand	Model	FCC ID
Notebook	DELL	M1330	E2KWM3945ABG

3.10. Table for Parameters of Test Software Setting

During testing, Channel & Power Controlling Software provided by the customer was used to control the operating channel as well as the output power level. The RF output power selection is for the setting of RF output power expected by the customer and is going to be fixed on the firmware of the final end product.

Power Parameters of IEEE 802.11ac MCS0/Nss2 20MHz

Test Software Version	Realtek 11ac 8812A USB WLAN MP Diagnostic Program 0.0027.20121102					
Frequency	5260 MHz	5300 MHz	5320 MHz	5500 MHz	5580 MHz	5700 MHz
MCS0/Nss2 20MHz	30/34	28/33	28/33	39/41	39/40	36/35

Power Parameters of IEEE 802.11ac MCS0/Nss2 40MHz

Test Software Version	Realtek 11ac 8812A USB WLAN MP Diagnostic Program 0.0027.20121102				
Frequency	5270 MHz	5310 MHz	5510 MHz	5550 MHz	5670 MHz
MCS0/Nss2 40MHz	32/36	25/32	31/37	41/42	41/40

Power Parameters of IEEE 802.11ac MCS0/Nss2 80MHz

Test Software Version	Realtek 11ac 8812A USB WLAN MP Diagnostic Program 0.0027.20121102	
Frequency	5290 MHz	5530 MHz
MCS0/Nss2 80MHz	22/30	33/38

Power Parameters of IEEE 802.11a

Test Software Version	Realtek 11ac 8812A USB WLAN MP Diagnostic Program 0.0027.20121102					
Frequency	5260 MHz	5300 MHz	5320 MHz	5500 MHz	5580 MHz	5700 MHz
IEEE 802.11a	21	20	20	31	34	33

3.11. EUT Operation during Test

The EUT was programmed to be in continuously transmitting mode.

3.12. Duty Cycle

IEEE 802.11ac MCS0/Nss2 20MHz

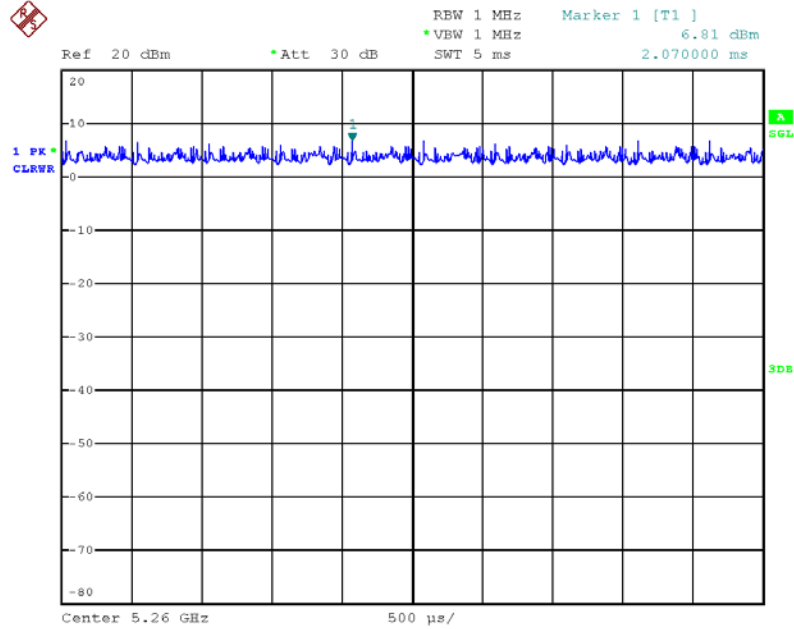

Date: 2.AUG.2013 19:54:05

IEEE 802.11ac MCS0/Nss2 40MHz

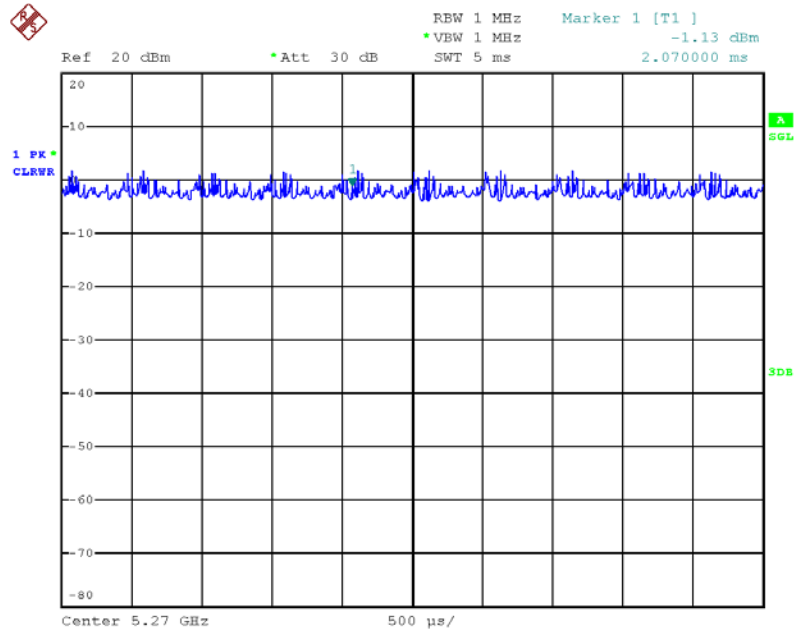

Date: 2.AUG.2013 19:55:28

IEEE 802.11ac MCS0/Nss2 80MHz

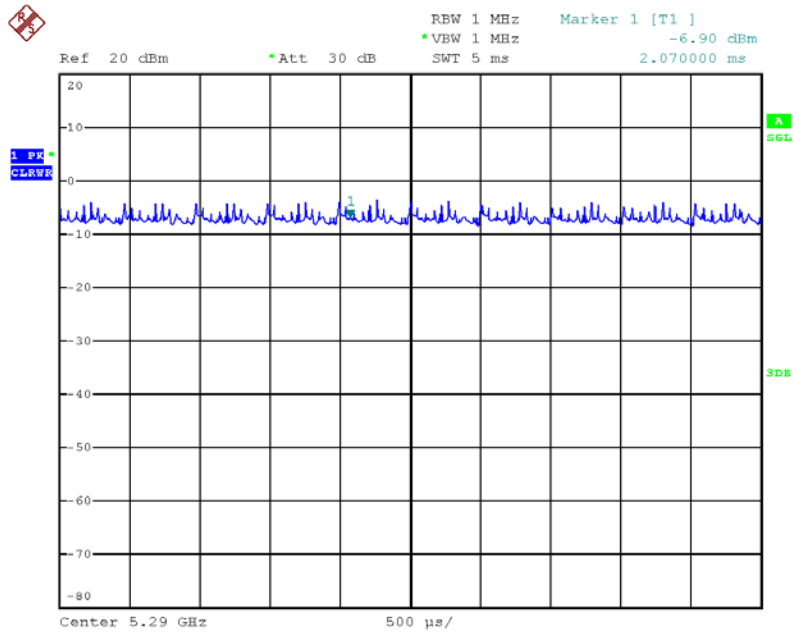

Date: 2.AUG.2013 19:56:17

IEEE 802.11a

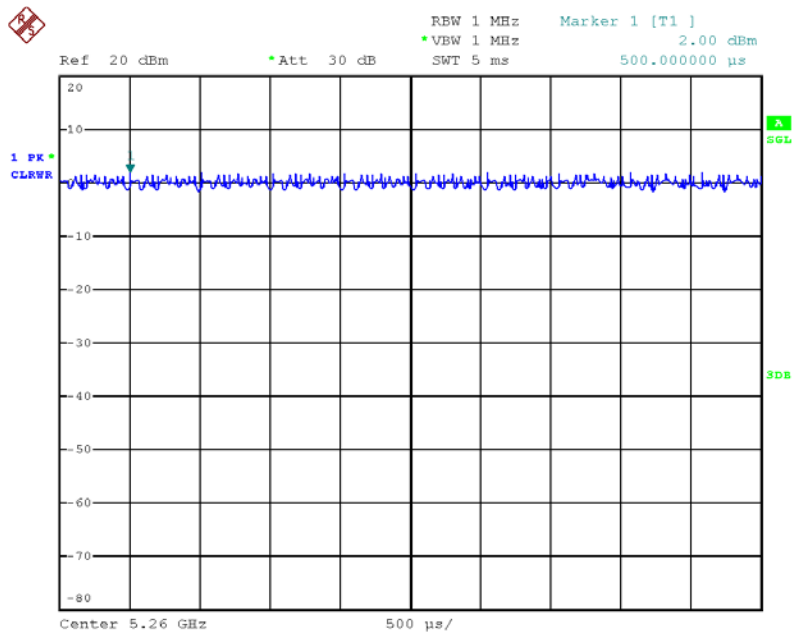

Date: 2.AUG.2013 19:52:49

3.13. Test Configurations

3.13.1. AC Power Line Conduction Emissions Test Configuration

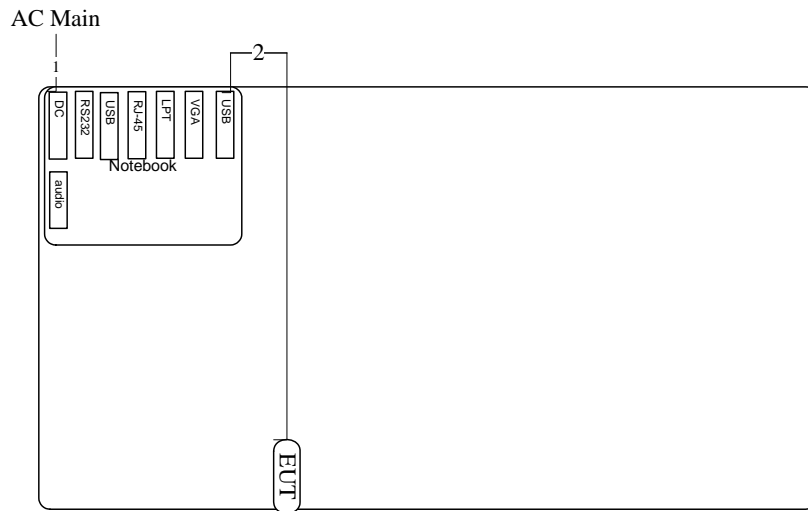

Item	Connection	Shield	Length
1	Power cable	No	2.6m
2	USB cable	No	1.8m

3.13.2. Radiation Emissions Test Configuration

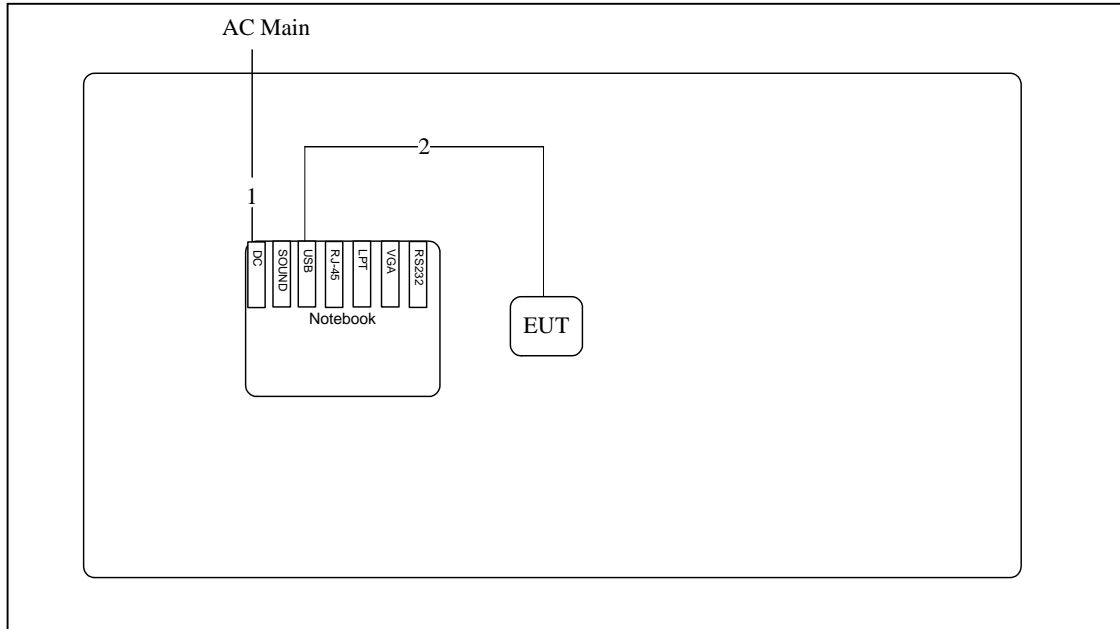

Item	Connection	Shield	Length
1	Power cable	No	2.6m
2	USB cable	No	1.8m

4. TEST RESULT

4.1. AC Power Line Conducted Emissions Measurement

4.1.1. Limit

For this product that is designed to connect to the AC power line, the radio frequency voltage that is conducted back onto the AC power line on any frequency or frequencies within the band 150 kHz to 30 MHz shall not exceed below limits table.

Frequency (MHz)	QP Limit (dBuV)	AV Limit (dBuV)
0.15~0.5	66~56	56~46
0.5~5	56	46
5~30	60	50

4.1.2. Measuring Instruments and Setting

Please refer to section 5 of equipments list in this report. The following table is the setting of the receiver.

Receiver Parameters	Setting
Attenuation	10 dB
Start Frequency	0.15 MHz
Stop Frequency	30 MHz
IF Bandwidth	9 kHz

4.1.3. Test Procedures

1. Configure the EUT according to ANSI C63.10. The EUT or host of EUT has to be placed 0.4 meter far from the conducting wall of the shielding room and at least 80 centimeters from any other grounded conducting surface.
2. Connect EUT or host of EUT to the power mains through a line impedance stabilization network (LISN).
3. All the support units are connected to the other LISNs. The LISN should provide 50uH/50ohms coupling impedance.
4. The frequency range from 150 kHz to 30 MHz was searched.
5. Set the test-receiver system to Peak Detect Function and Specified Bandwidth with Maximum Hold Mode.
6. The measurement has to be done between each power line and ground at the power terminal.

4.1.4. Test Setup Layout

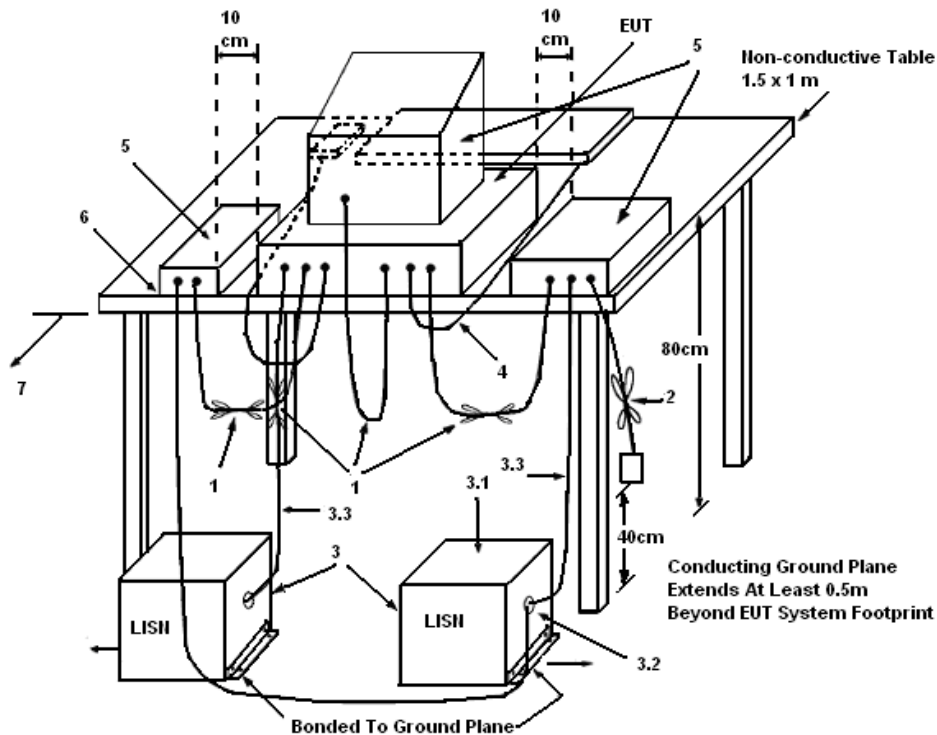

LEGEND:

- (1) Interconnecting cables that hang closer than 40 cm to the ground plane shall be folded back and forth in the center forming a bundle 30 to 40 cm long.
- (2) I/O cables that are not connected to a peripheral shall be bundled in the center. The end of the cable may be terminated, if required, using the correct terminating impedance. The overall length shall not exceed 1 m.
- (3) EUT connected to one LISN. Unused LISN measuring port connectors shall be terminated in 50 Ω . LISN can be placed on top of, or immediately beneath, reference ground plane.
 - (3.1) All other equipment powered from additional LISN(s).
 - (3.2) Multiple outlet strip can be used for multiple power cords of non-EUT equipment.
 - (3.3) LISN at least 80 cm from nearest part of EUT chassis.
- (4) Cables of hand-operated devices, such as keyboards, mice, etc., shall be placed as for normal use.
- (5) Non-EUT components of EUT system being tested.
- (6) Rear of EUT, including peripherals, shall all be aligned and flush with rear of tabletop.
- (7) Rear of tabletop shall be 40 cm removed from a vertical conducting plane that is bonded to the ground plane.

4.1.5. Test Deviation

There is no deviation with the original standard.

4.1.6. EUT Operation during Test

The EUT was placed on the test table and programmed in normal function.

4.1.7. Results of AC Power Line Conducted Emissions Measurement

Temperature	24°C	Humidity	58%
Test Engineer	Sollo Luo	Phase	Line
Configuration	CTX		

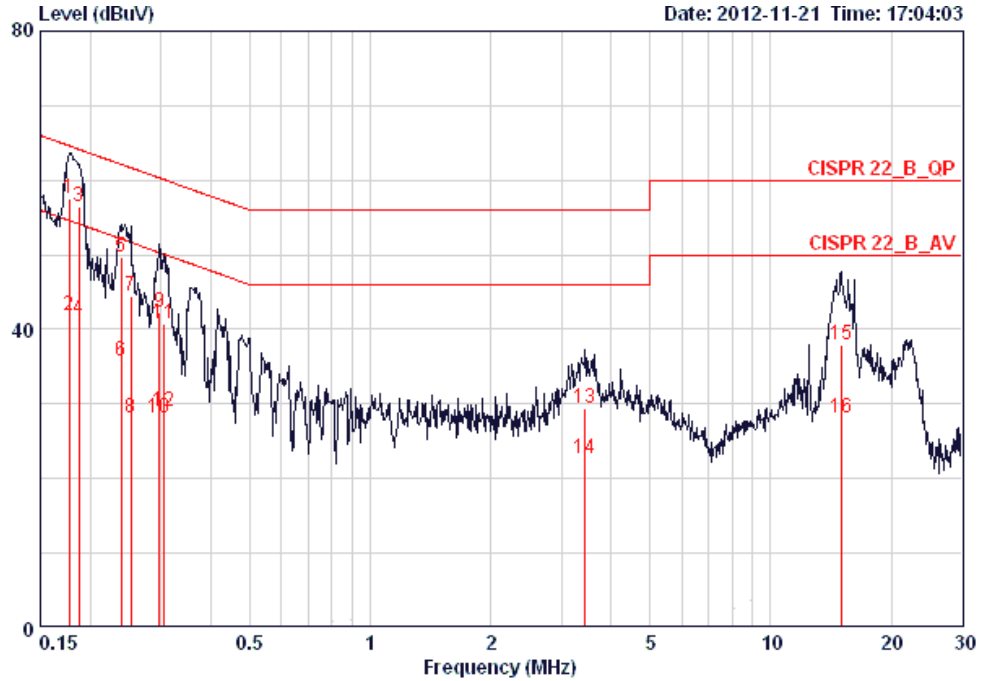

	Freq	Level	Over Limit	Limit Line	Read Level	LISN Factor	Cable Loss	Pol/Phase	Remark
	MHz	dBuV	dB	dBuV	dBuV	dB	dB		
1	0.17678	57.45	-7.19	64.64	57.10	0.15	0.20	LINE	QP
2	0.17678	41.81	-12.83	54.64	41.46	0.15	0.20	LINE	AVERAGE
3	0.18739	56.49	-7.66	64.15	56.14	0.15	0.20	LINE	QP
4	0.18739	41.48	-12.67	54.15	41.13	0.15	0.20	LINE	AVERAGE
5	0.23910	49.66	-12.47	62.13	49.31	0.15	0.20	LINE	QP
6	0.23910	35.76	-16.37	52.13	35.41	0.15	0.20	LINE	AVERAGE
7	0.25211	44.50	-17.19	61.69	44.15	0.15	0.20	LINE	QP
8	0.25211	28.19	-23.50	51.69	27.84	0.15	0.20	LINE	AVERAGE
9	0.29712	42.23	-18.09	60.32	41.88	0.15	0.20	LINE	QP
10	0.29712	28.20	-22.12	50.32	27.85	0.15	0.20	LINE	AVERAGE
11	0.30509	40.73	-19.37	60.10	40.38	0.15	0.20	LINE	QP
12	0.30509	29.01	-21.09	50.10	28.66	0.15	0.20	LINE	AVERAGE
13	3.436	29.49	-26.51	56.00	28.99	0.21	0.29	LINE	QP
14	3.436	22.78	-23.22	46.00	22.28	0.21	0.29	LINE	AVERAGE
15	14.986	38.03	-21.97	60.00	37.22	0.41	0.40	LINE	QP
16	14.986	28.05	-21.95	50.00	27.24	0.41	0.40	LINE	AVERAGE

Temperature	24°C	Humidity	58%
Test Engineer	Sollo Luo	Phase	Neutral
Configuration	CTX		

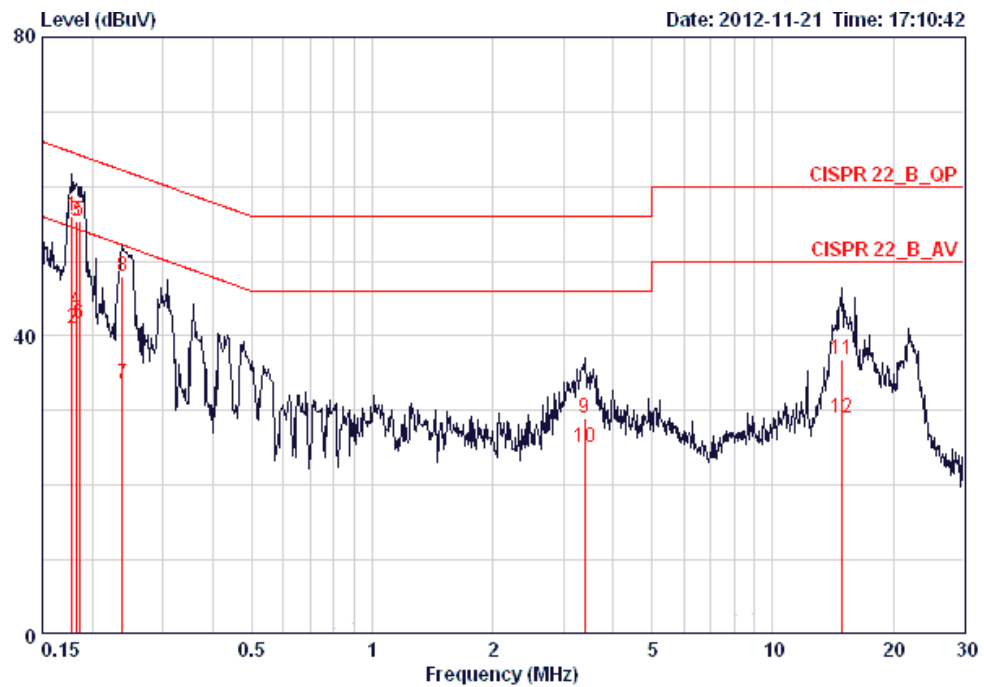

	Freq	Level	Over Limit	Limit Line	Read Level	LISN Factor	Cable Loss	Pol/Phase	Remark
	MHz	dBuV	dB	dBuV	dBuV	dB	dB		
1	0.17772	56.02	-8.57	64.59	55.74	0.08	0.20	NEUTRAL	QP
2	0.17772	40.99	-13.60	54.59	40.71	0.08	0.20	NEUTRAL	AVERAGE
3	0.18249	55.47	-8.90	64.37	55.19	0.08	0.20	NEUTRAL	QP
4	0.18249	43.29	-11.08	54.37	43.01	0.08	0.20	NEUTRAL	AVERAGE
5	0.18541	55.37	-8.87	64.24	55.09	0.08	0.20	NEUTRAL	QP
6	0.18541	41.63	-12.61	54.24	41.35	0.08	0.20	NEUTRAL	AVERAGE
7	0.23784	33.63	-18.54	52.17	33.35	0.08	0.20	NEUTRAL	AVERAGE
8	0.23784	47.94	-14.23	62.17	47.66	0.08	0.20	NEUTRAL	QP
9	3.399	29.02	-26.98	56.00	28.61	0.12	0.28	NEUTRAL	QP
10	3.399	25.15	-20.85	46.00	24.74	0.12	0.28	NEUTRAL	AVERAGE
11	14.828	36.80	-23.20	60.00	36.09	0.31	0.40	NEUTRAL	QP
12	14.828	28.97	-21.03	50.00	28.26	0.31	0.40	NEUTRAL	AVERAGE

Note:

Level = Read Level + LISN Factor + Cable Loss.

4.2. 26dB Bandwidth & 99% Occupied Bandwidth Measurement

4.2.1. Limit

No restriction limits.

4.2.2. Measuring Instruments and Setting

Please refer to section 5 of equipments list in this report. The following table is the setting of the spectrum analyzer.

26dB Bandwidth	
Spectrum Parameters	Setting
Attenuation	Auto
Span Frequency	> 26dB Bandwidth
RBW	Approximately 1% of the emission bandwidth
VBW	VBW > RBW
Detector	Peak
Trace	Max Hold
Sweep Time	Auto
99% Occupied Bandwidth	
Spectrum Parameters	Setting
Span	1.5 times to 5.0 times the OBW
RBW	1 % to 5 % of the OBW
VBW	$\geq 3 \times \text{RBW}$
Detector	Peak
Trace	Max Hold

4.2.3. Test Procedures

1. The transmitter output (antenna port) was connected to the spectrum analyzer in peak hold mode.
2. Measure the maximum width of the emission that is 26 dB down from the peak of the emission. Compare this with the RBW setting of the analyzer. Readjust RBW and repeat measurement as needed until the RBW/EBW ratio is approximately 1%.

4.2.4. Test Setup Layout

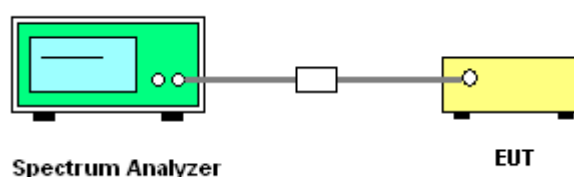

4.2.5. Test Deviation

There is no deviation with the original standard.

4.2.6. EUT Operation during Test

The EUT was programmed to be in continuously transmitting mode.

4.2.7. Test Result of 26dB Bandwidth & 99% Occupied Bandwidth

Temperature	23°C	Humidity	63%
Test Engineer	David Tseng	Configurations	IEEE 802.11ac

Configuration IEEE 802.11ac MCS0/Nss2 20MHz / Chain 1 + Chain 2

Channel	Frequency	26dB Bandwidth (MHz)	99% Occupied Bandwidth (MHz)
52	5260 MHz	21.28	17.84
60	5300 MHz	21.12	17.92
64	5320 MHz	21.12	17.92
100	5500 MHz	21.20	17.92
116	5580 MHz	20.88	17.92
140	5700 MHz	20.88	17.92

Configuration IEEE 802.11ac MCS0/Nss2 40MHz / Chain 1 + Chain 2

Channel	Frequency	26dB Bandwidth (MHz)	99% Occupied Bandwidth (MHz)
54	5270 MHz	41.44	36.48
62	5310 MHz	42.24	36.48
102	5510 MHz	41.92	36.48
110	5550 MHz	41.60	36.48
134	5670 MHz	41.92	36.48

Configuration IEEE 802.11ac MCS0/Nss2 80MHz / Chain 1 + Chain 2

Channel	Frequency	26dB Bandwidth (MHz)	99% Occupied Bandwidth (MHz)
58	5290 MHz	79.68	75.84
106	5530 MHz	81.92	76.16

Temperature	23°C	Humidity	63%
Test Engineer	David Tseng	Configurations	IEEE 802.11a

Configuration IEEE 802.11a / Chain 2

Channel	Frequency	26dB Bandwidth (MHz)	99% Occupied Bandwidth (MHz)
52	5260 MHz	20.80	16.80
60	5300 MHz	20.80	16.80
64	5320 MHz	20.72	16.80
100	5500 MHz	20.96	16.88
116	5580 MHz	20.96	16.96
140	5700 MHz	20.88	16.88

26dB Bandwidth & 99% Occupied Bandwidth Plot on Configuration IEEE 802.11ac MCS0/Nss2
20MHz / Chain 1 + Chain 2 / 5260 MHz

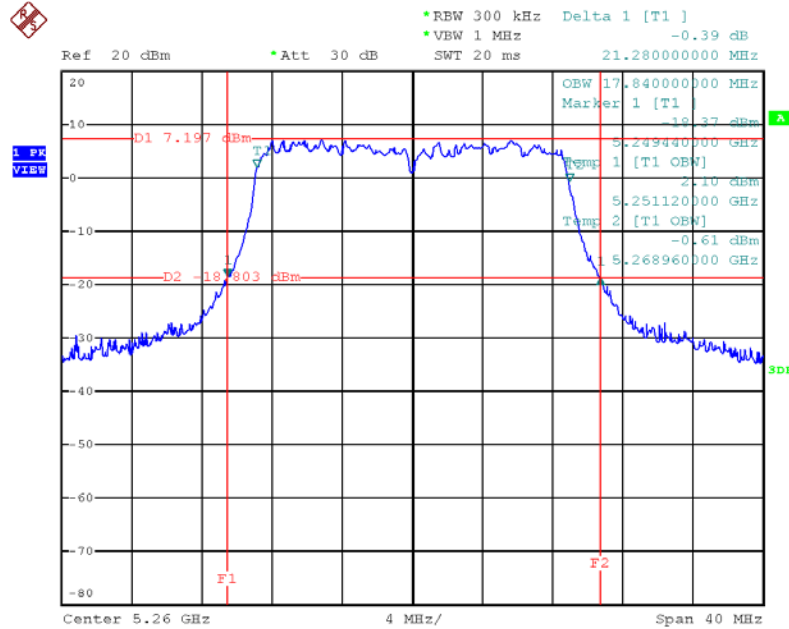

Date: 2.AUG.2013 17:28:32

26dB Bandwidth & 99% Occupied Bandwidth Plot on Configuration IEEE 802.11ac MCS0/Nss2
20MHz / Chain 1 + Chain 2 / 5300 MHz

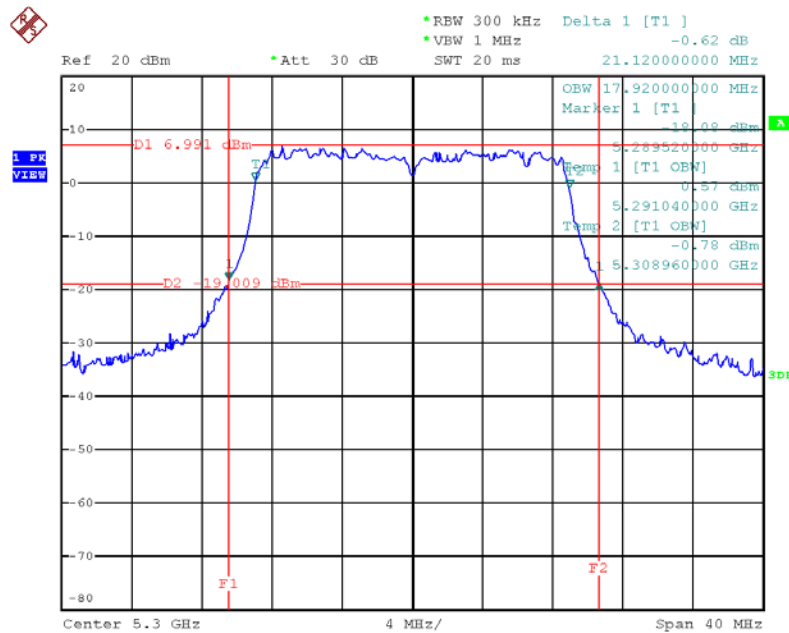

Date: 2.AUG.2013 17:29:34

26dB Bandwidth & 99% Occupied Bandwidth Plot on Configuration IEEE 802.11ac MCS0/Nss2
20MHz / Chain 1 + Chain 2 / 5320 MHz

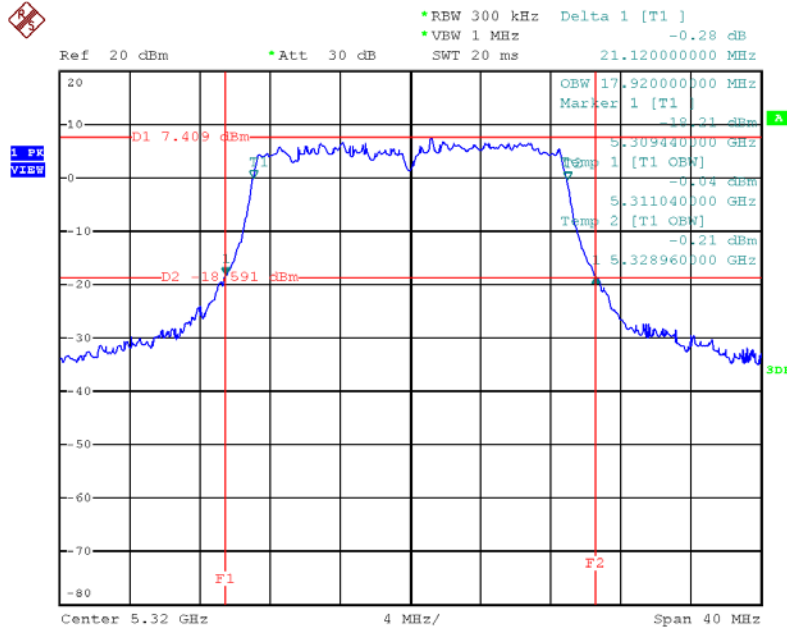

Date: 2.AUG.2013 17:30:31

26dB Bandwidth & 99% Occupied Bandwidth Plot on Configuration IEEE 802.11ac MCS0/Nss2
20MHz / Chain 1 + Chain 2 / 5550 MHz

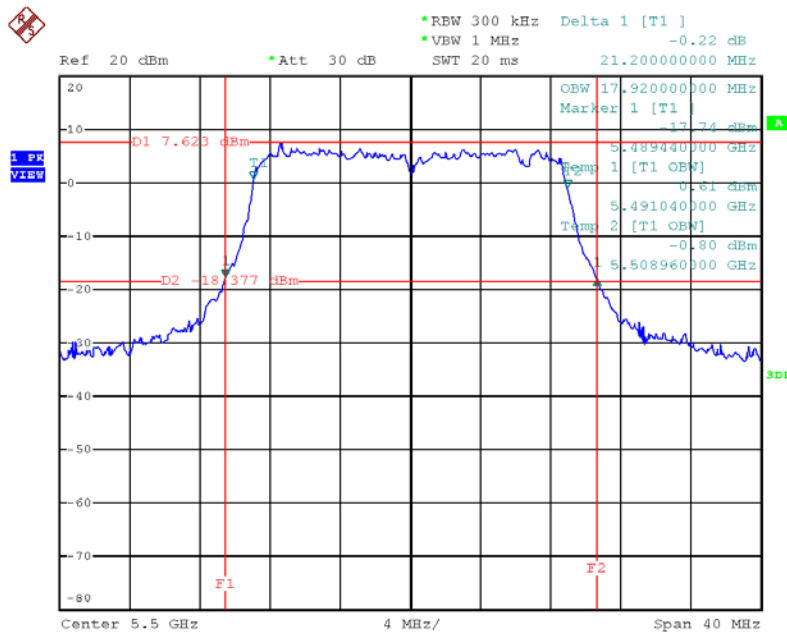

Date: 2.AUG.2013 17:39:21

26dB Bandwidth & 99% Occupied Bandwidth Plot on Configuration IEEE 802.11ac MCS0/Nss2
20MHz / Chain 1 + Chain 2 / 5580 MHz

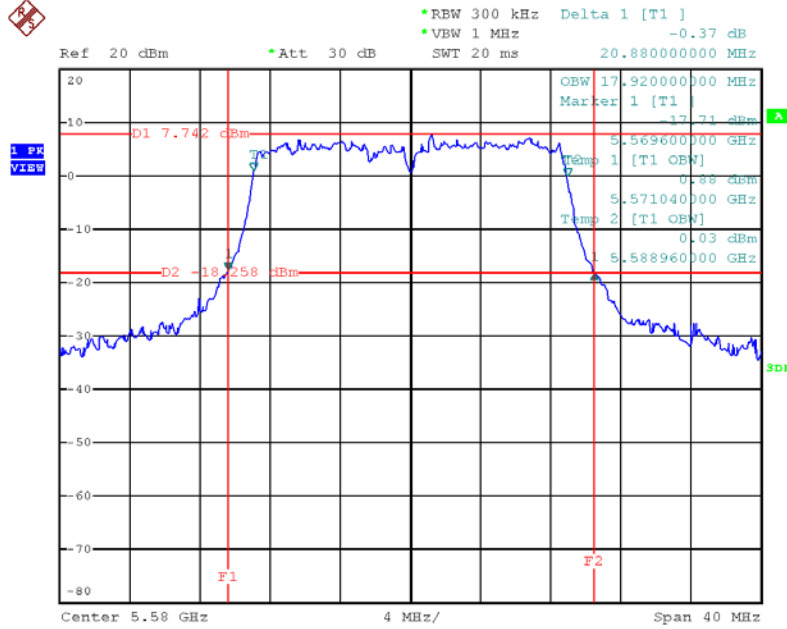

Date: 2.AUG.2013 17:40:39

26dB Bandwidth & 99% Occupied Bandwidth Plot on Configuration IEEE 802.11ac MCS0/Nss2
20MHz / Chain 1 + Chain 2 / 5700 MHz

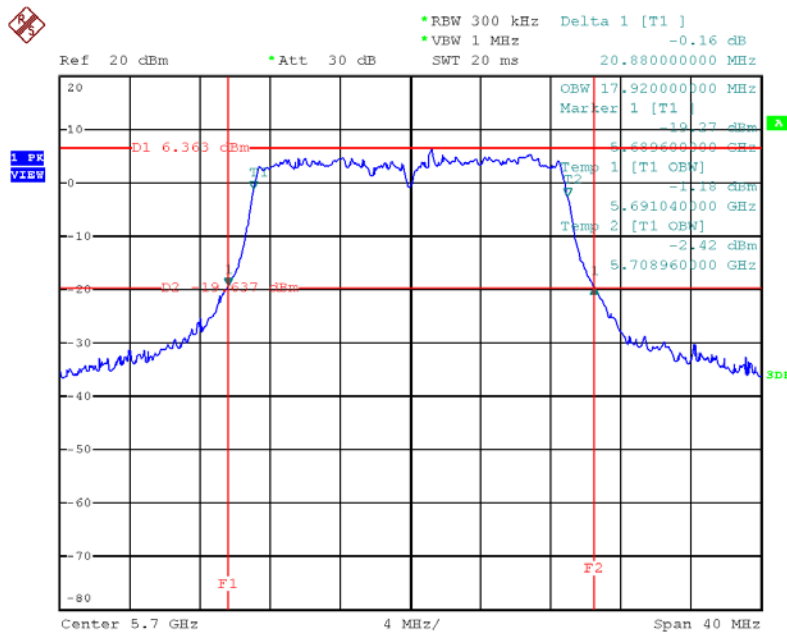

Date: 2.AUG.2013 17:41:27

26dB Bandwidth & 99% Occupied Bandwidth Plot on Configuration IEEE 802.11ac MCS0/Nss2
40MHz / Chain 1 + Chain 2 / 5270 MHz

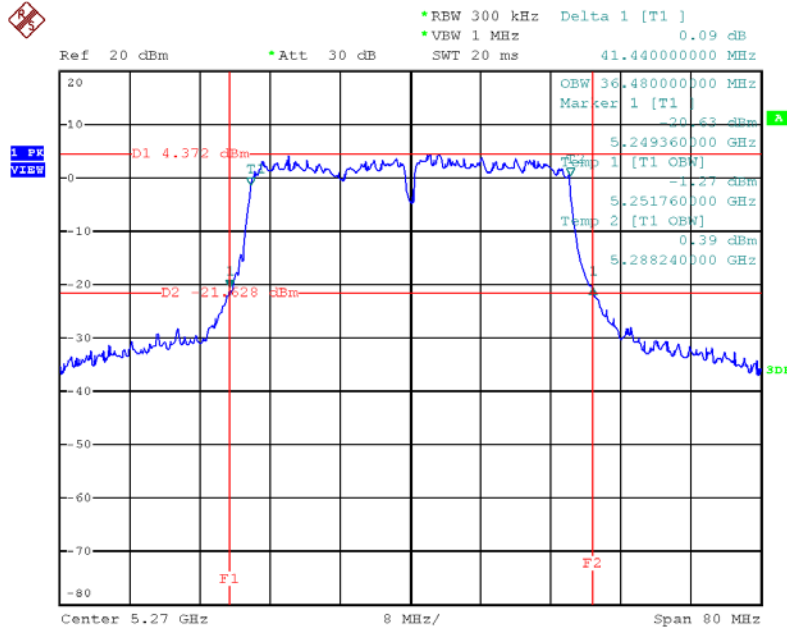

Date: 2.AUG.2013 17:44:23

26dB Bandwidth & 99% Occupied Bandwidth Plot on Configuration IEEE 802.11ac MCS0/Nss2
40MHz / Chain 1 + Chain 2 / 5310 MHz

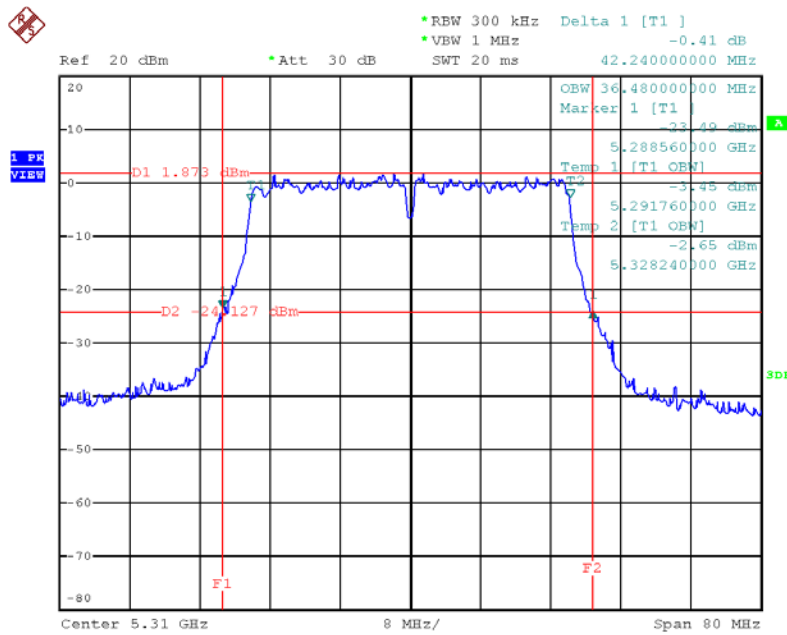

Date: 2.AUG.2013 17:45:16

26dB Bandwidth & 99% Occupied Bandwidth Plot on Configuration IEEE 802.11ac MCS0/Nss2
40MHz / Chain 1 + Chain 2 / 5510 MHz

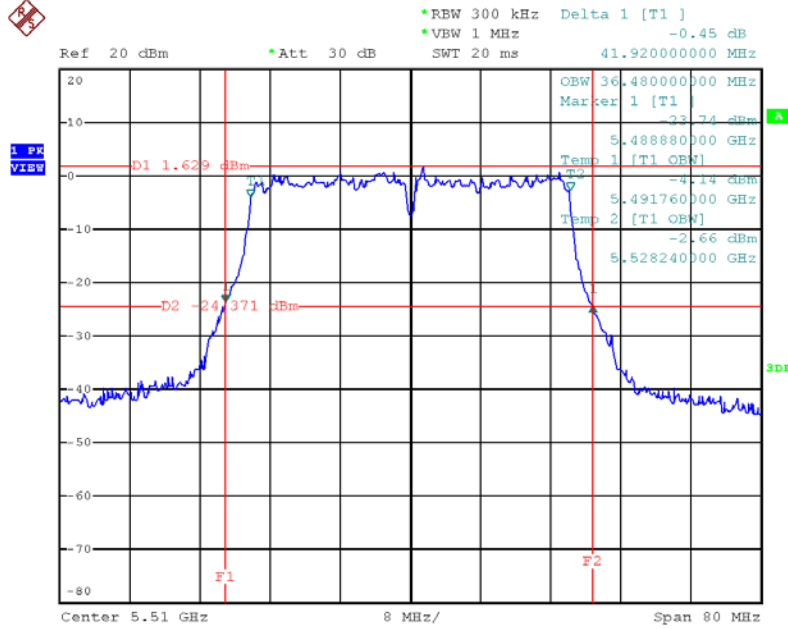

Date: 2.AUG.2013 17:46:54

26dB Bandwidth & 99% Occupied Bandwidth Plot on Configuration IEEE 802.11ac MCS0/Nss2
40MHz / Chain 1 + Chain 2 / 5550 MHz

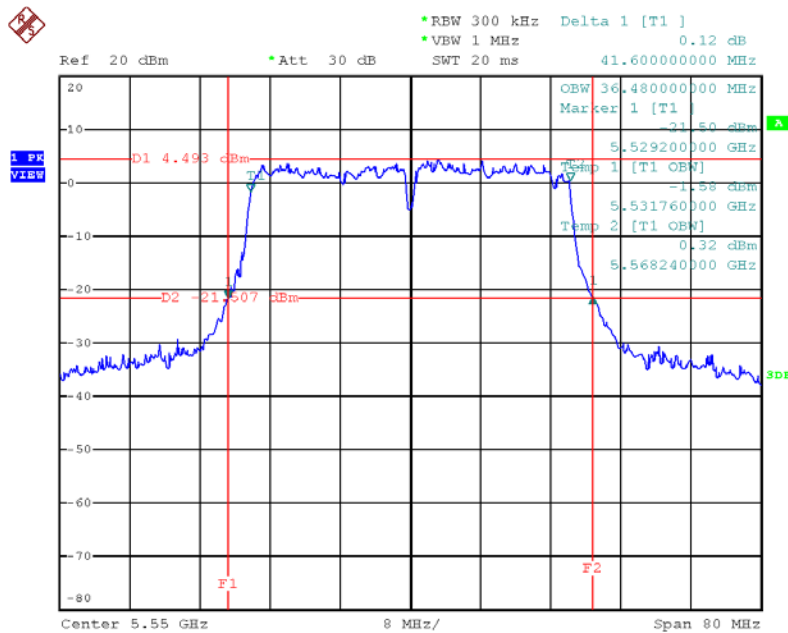

Date: 2.AUG.2013 17:47:49

26dB Bandwidth & 99% Occupied Bandwidth Plot on Configuration IEEE 802.11ac MCS0/Nss2
40MHz / Chain 1 + Chain 2 / 5670MHz

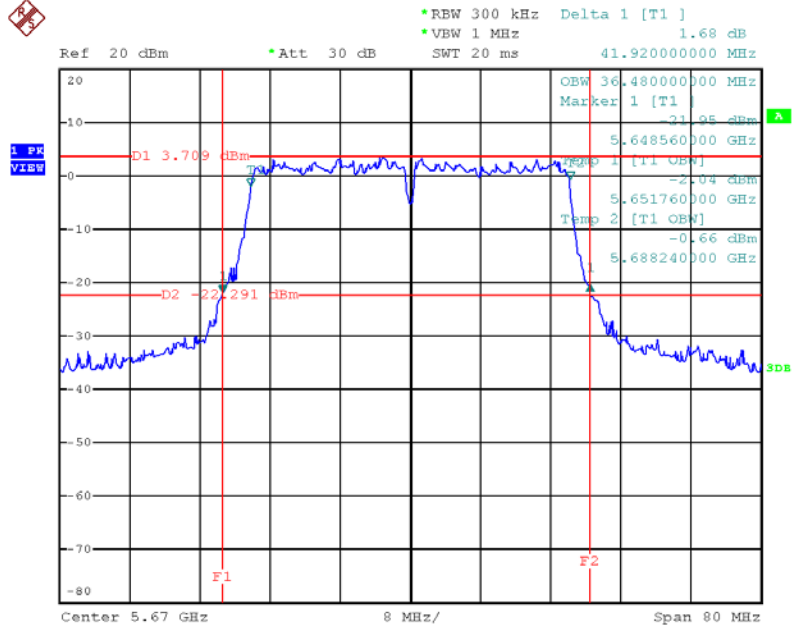

Date: 2.AUG.2013 17:48:37

26dB Bandwidth & 99% Occupied Bandwidth Plot on Configuration IEEE 802.11ac MCS0/Nss2
80MHz / Chain 1 + Chain 2 / 5290 MHz

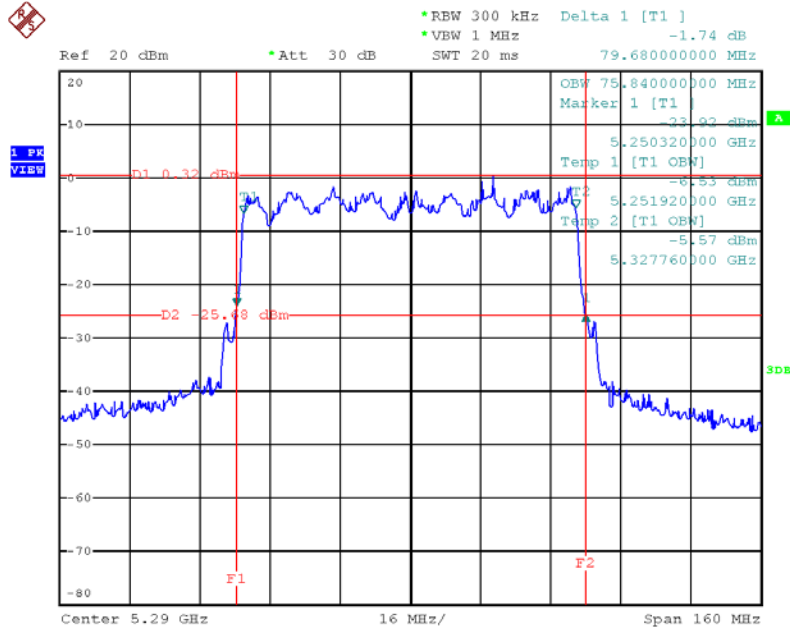

Date: 2.AUG.2013 17:54:52

26dB Bandwidth & 99% Occupied Bandwidth Plot on Configuration IEEE 802.11ac MCS0/Nss2
80MHz / Chain 1 + Chain 2 / 5530 MHz

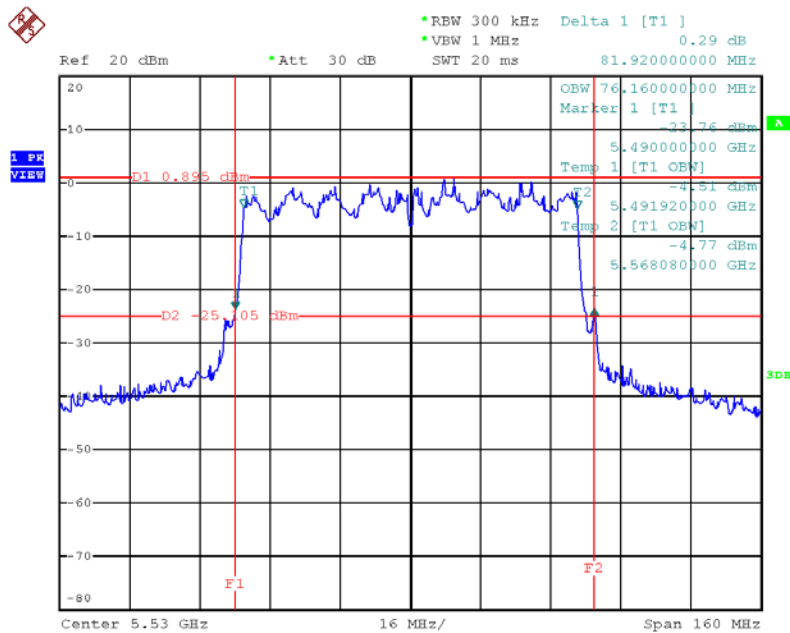

Date: 2.AUG.2013 17:56:00

26dB Bandwidth & 99% Occupied Bandwidth Plot on Configuration IEEE 802.11a / Chain 2 / 5260 MHz

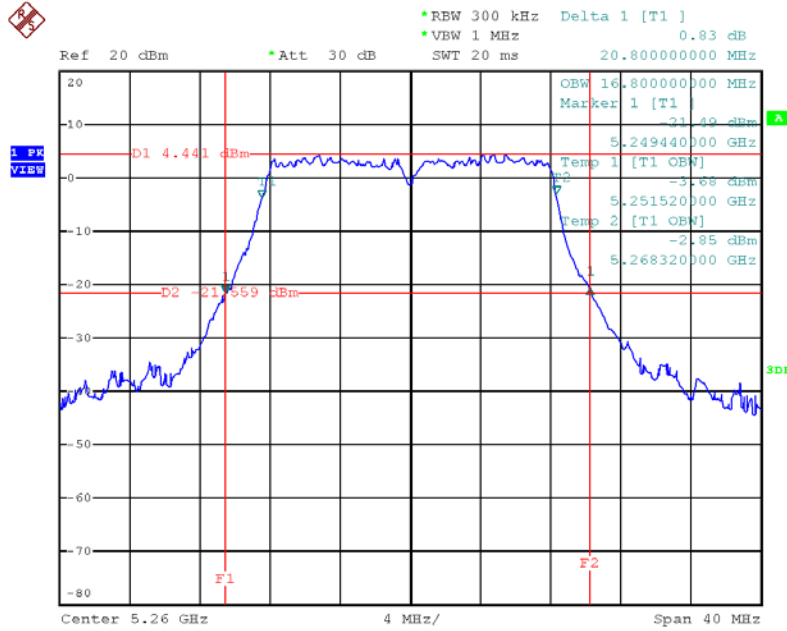

Date: 2.AUG.2013 17:13:35

26dB Bandwidth & 99% Occupied Bandwidth Plot on Configuration IEEE 802.11a / Chain 2 / 5300 MHz

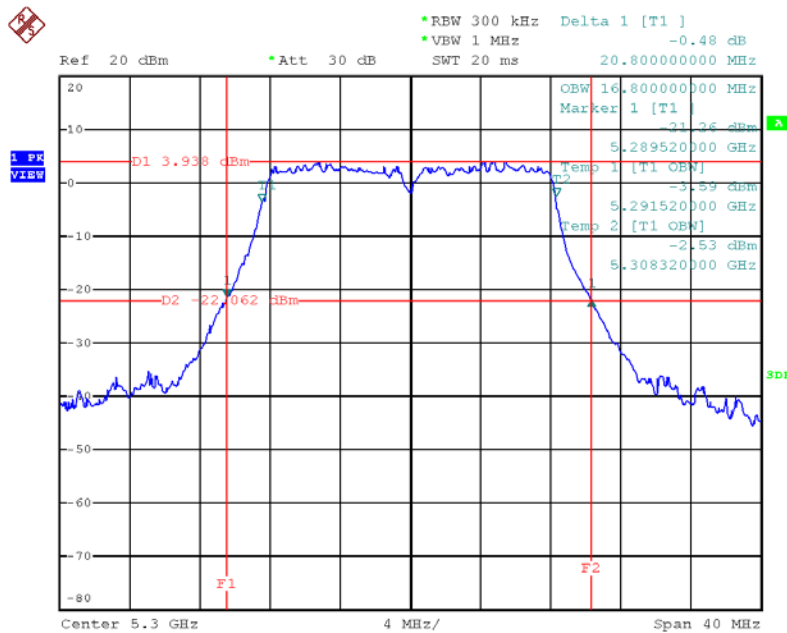

Date: 2.AUG.2013 17:15:10

26dB Bandwidth & 99% Occupied Bandwidth Plot on Configuration IEEE 802.11a / Chain 2 / 5320 MHz

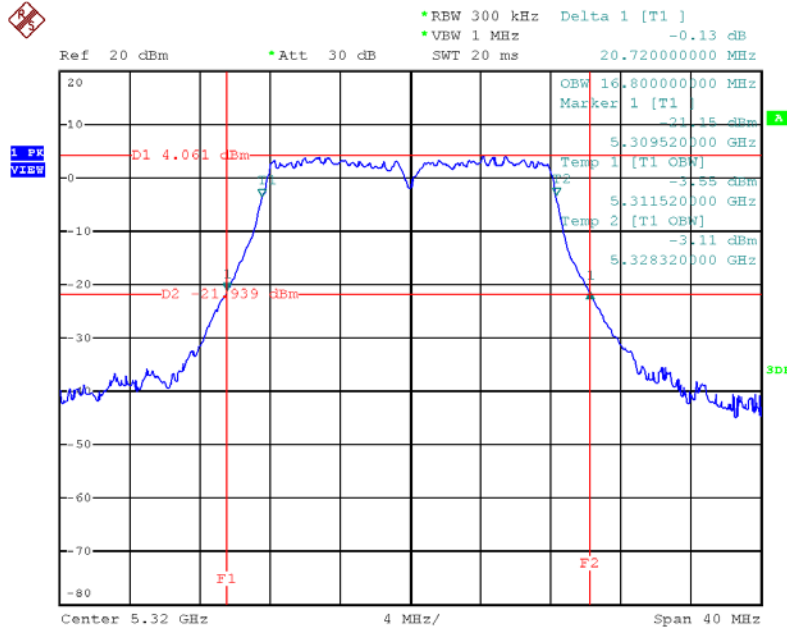

Date: 2.AUG.2013 17:19:15

26dB Bandwidth & 99% Occupied Bandwidth Plot on Configuration IEEE 802.11a / Chain 2 / 5500 MHz

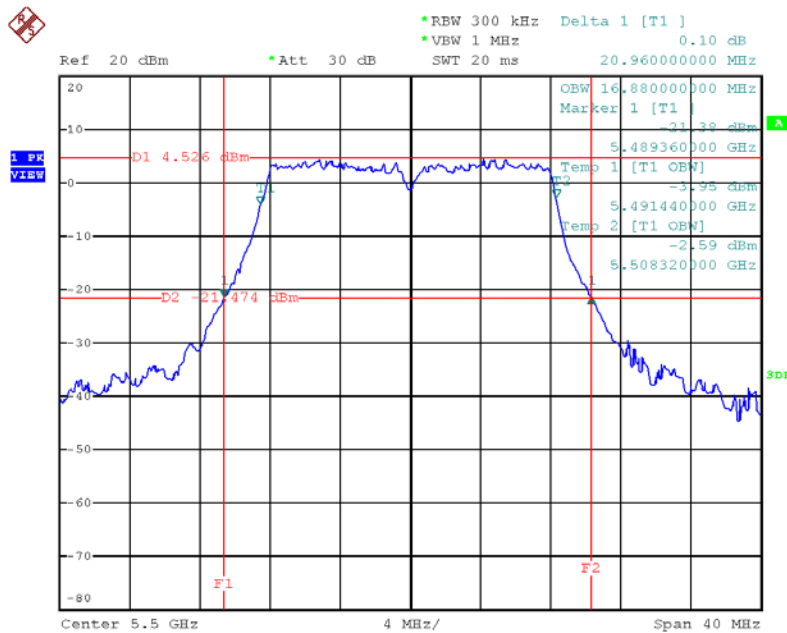

Date: 2.AUG.2013 17:20:09

26dB Bandwidth & 99% Occupied Bandwidth Plot on Configuration IEEE 802.11a / Chain 2 / 5580 MHz

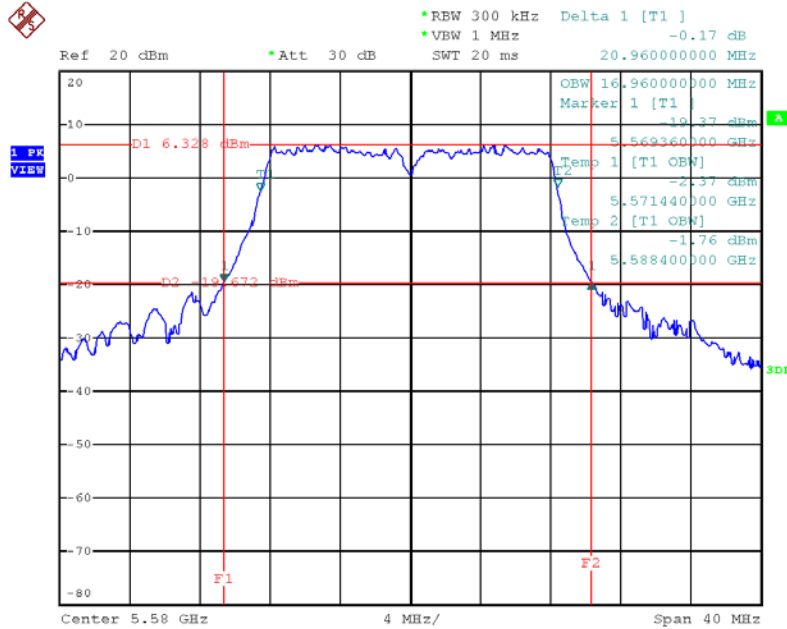

Date: 2.AUG.2013 17:21:53

26dB Bandwidth & 99% Occupied Bandwidth Plot on Configuration IEEE 802.11a / Chain 2 / 5700 MHz

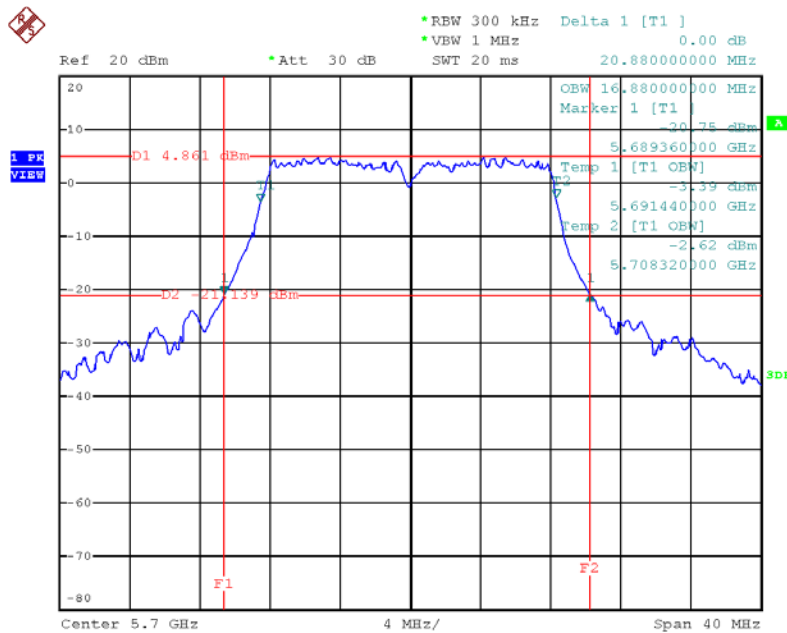

Date: 2.AUG.2013 17:22:41

4.3. Maximum Conducted Output Power Measurement

4.3.1. Limit

For the 5.25-5.35 GHz and 5.470-5.725 GHz bands, the maximum conducted output power over the frequency bands of operation shall not exceed the lesser of 250 mW (24dBm) or 11 dBm + 10log B, where B is the 26-dB emission bandwidth in MHz. If transmitting antennas of directional gain greater than 6 dBi are used, both the maximum conducted output power and the peak power spectral density shall be reduced by the amount in dB that the directional gain of the antenna exceeds 6 dBi.

For the band 5.725~5.825 GHz, the maximum conducted output power over the frequency band of operation shall not exceed the lesser of 1 W or 17 dBm + 10 log B, where B is the 26-dB emission bandwidth in MHz. In addition, the peak power spectral density shall not exceed 17 dBm in any 1MHz band. If transmitting antennas of directional gain greater than 6 dBi are used, both the maximum conducted output power and the peak power spectral density shall be reduced by the amount in dB that the directional gain of the antenna exceeds 6 dBi. However, fixed point-to-point U-NII devices operating in this band may employ transmitting antennas with directional gain up to 23 dBi without any corresponding reduction in the transmitter peak output power or peak power spectral density. For fixed, point-to-point U-NII transmitters that employ a directional antenna gain greater than 23 dBi, a 1 dB reduction in peak transmitter power and peak power spectral density for each 1 dB of antenna gain in excess of 23 dBi would be required.

4.3.2. Measuring Instruments and Setting

The following table is the setting of the peak power meter.

Power Meter Parameter	Setting
Detector	AVERAGE

4.3.3. Test Procedures

1. The transmitter output (antenna port) was connected to the power meter.
2. Test was performed in accordance with KDB 789033 D01 v01r03 for Compliance Testing of Unlicensed National Information Infrastructure (U-NII) Devices - Part 15, Subpart E, section (E) Maximum conducted output power =>(3) Method PM (Measurement using an RF average power meter) Multiple antenna systems was performed in accordance with KDB 662911 D01 v02 Emissions Testing of Transmitters with Multiple Outputs in the Same Band.
3. When measuring maximum conducted output power with multiple antenna systems, add every result of the values by mathematic formula.

4.3.4. Test Setup Layout

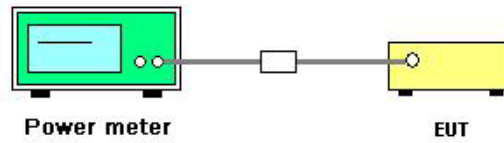

4.3.5. Test Deviation

There is no deviation with the original standard.

4.3.6. EUT Operation during Test

The EUT was programmed to be in continuously transmitting mode.

4.3.7. Test Result of Maximum Conducted Output Power

Temperature	23°C	Humidity	63%
Test Engineer	David Tseng	Configurations	IEEE 802.11ac
Test Date	Aug. 02, 2013		

Configuration IEEE 802.11ac MCS0/Nss2 20MHz / Chain 1 + Chain 2

Channel	Frequency	Conducted Power (dBm)		Total Conducted Output Power (dBm)	Max. Limit (dBm)	Result
		Chain 1	Chain 2			
52	5260 MHz	14.65	15.01	17.84	24.00	Complies
60	5300 MHz	14.19	14.48	17.35	24.00	Complies
64	5320 MHz	14.45	14.82	17.65	24.00	Complies
100	5500 MHz	14.31	14.76	17.55	24.00	Complies
116	5580 MHz	14.78	15.36	18.09	24.00	Complies
140	5700 MHz	14.49	14.89	17.70	24.00	Complies

Configuration IEEE 802.11ac MCS0/Nss2 40MHz / Chain 1 + Chain 2

Channel	Frequency	Conducted Power (dBm)		Total Conducted Output Power (dBm)	Max. Limit (dBm)	Result
		Chain 1	Chain 2			
54	5270 MHz	14.67	15.01	17.85	24.00	Complies
62	5310 MHz	13.53	12.65	16.12	24.00	Complies
102	5510 MHz	12.58	11.13	14.93	24.00	Complies
110	5550 MHz	14.52	14.99	17.77	24.00	Complies
134	5670 MHz	14.53	15.06	17.81	24.00	Complies

Configuration IEEE 802.11ac MCS0/Nss2 80MHz / Chain 1 + Chain 2

Channel	Frequency	Conducted Power (dBm)		Total Conducted Output Power (dBm)	Max. Limit (dBm)	Result
		Chain 1	Chain 2			
58	5290 MHz	12.25	10.35	14.41	24.00	Complies
106	5530 MHz	13.35	12.29	15.86	24.00	Complies

Temperature	23°C	Humidity	63%
Test Engineer	David Tseng	Configurations	IEEE 802.11a
Test Date	Aug. 02, 2013		

Configuration IEEE 802.11a / Chain 2

Channel	Frequency	Conducted Power (dBm)	Max. Limit (dBm)	Result
52	5260 MHz	13.63	24.00	Complies
60	5300 MHz	13.61	24.00	Complies
64	5320 MHz	13.72	24.00	Complies
100	5500 MHz	14.59	24.00	Complies
116	5580 MHz	15.83	24.00	Complies
140	5700 MHz	15.55	24.00	Complies

4.4. Power Spectral Density Measurement

4.4.1. Limit

The power spectral density is defined as the highest level of power in dBm per MHz generated by the transmitter within the power envelope. The following table is power spectral density limits and decrease power density limit rule refer to section 4.3.1.

Frequency Range	Power Spectral Density limit (dBm/MHz)
5.25-5.35 GHz	11
5.470-5.725 GHz	11

4.4.2. Measuring Instruments and Setting

Please refer to section 5 of equipments list in this report. The following table is the setting of the spectrum analyzer.

Spectrum Parameter	Setting
Attenuation	Auto
Span Frequency	Encompass the entire emissions bandwidth (EBW) of the signal
RBW	1000 kHz
VBW	3000 kHz
Detector	RMS
Trace	AVERAGE
Sweep Time	Auto
Trace Average	100 times

4.4.3. Test Procedures

1. The transmitter output (antenna port) was connected RF switch to the spectrum analyzer.
2. Test was performed in accordance with KDB 789033 D01 v01r03 for Compliance Testing of Unlicensed National Information Infrastructure (U-NII) Devices - Part 15, Subpart E, section (C) Maximum conducted output power => (d) Method SA-2 (trace averaging across on and off times of the EUT transmissions, followed by duty cycle correction).
3. Multiple antenna systems was performed in accordance KDB 662911 D01 v02 in-Band Power Spectral Density (PSD) Measurements (a) Measure and sum the spectra across the outputs.
4. When measuring first spectral bin of output 1 is summed with that in the first spectral bin of output 2 and that from the first spectral bin of output 3 and so on up to the Nth output to obtain the value for the first frequency bin of the summed spectrum. The summed spectrum value for each of the other frequency bins is computed in the same way.

4.4.4. Test Setup Layout

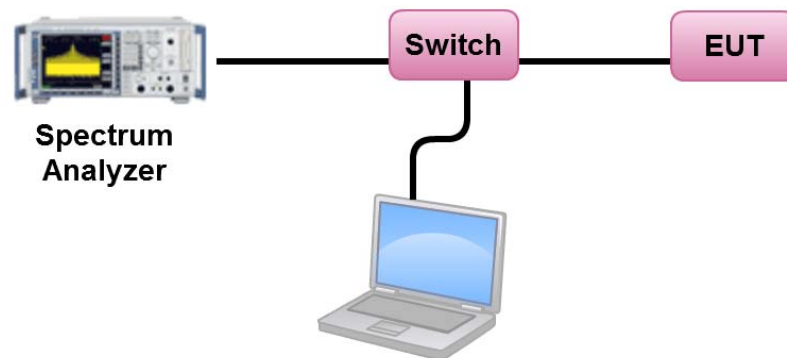

4.4.5. Test Deviation

There is no deviation with the original standard.

4.4.6. EUT Operation during Test

The EUT was programmed to be in continuously transmitting mode.

4.4.7. Test Result of Power Spectral Density

Temperature	23°C	Humidity	63%
Test Engineer	David Tseng	Configurations	IEEE 802.11ac
Test Date	Aug. 02, 2013		

Configuration IEEE 802.11ac MCS0/Nss2 20MHz / Chain 1 + Chain 2

Channel	Frequency	Total Power Density (dBm/MHz)	Max. Limit (dBm/MHz)	Result
52	5260 MHz	4.37	11.00	Complies
60	5300 MHz	6.69	11.00	Complies
64	5320 MHz	6.77	11.00	Complies
100	5500 MHz	6.44	11.00	Complies
116	5580 MHz	6.64	11.00	Complies
140	5700 MHz	5.28	11.00	Complies

Note: Directional gain= $G_{ANT}+10\log(N_{ANT}/N_{ss})=3.55\text{dBi} < 6\text{dBi}$, so Band2 limit doesn' reduce.

Directional gain= $G_{ANT}+10\log(N_{ANT}/N_{ss})=3.73\text{dBi} < 6\text{dBi}$, so Band3 limit doesn' reduce.

Configuration IEEE 802.11ac MCS0/Nss2 40MHz / Chain 1 + Chain 2

Channel	Frequency	Total Power Density (dBm/MHz)	Max. Limit (dBm/MHz)	Result
54	5270 MHz	3.66	11.00	Complies
62	5310 MHz	1.18	11.00	Complies
102	5510 MHz	0.07	11.00	Complies
110	5550 MHz	3.49	11.00	Complies
134	5670 MHz	2.74	11.00	Complies

Note: Directional gain= $G_{ANT}+10\log(N_{ANT}/N_{ss})=3.55\text{dBi} < 6\text{dBi}$, so Band2 limit=11 dBm/MHz

Directional gain= $G_{ANT}+10\log(N_{ANT}/N_{ss})=3.73\text{dBi} < 6\text{dBi}$, so Band3 limit=11 dBm/MHz

Configuration IEEE 802.11ac MCS0/Nss2 80MHz / Chain 1 + Chain 2

Channel	Frequency	Total Power Density (dBm/MHz)	Max. Limit (dBm/MHz)	Result
58	5290 MHz	-2.33	11.00	Complies
106	5530 MHz	-1.45	11.00	Complies

Note: Directional gain= $G_{ANT}+10\log(N_{ANT}/N_{ss})=3.55\text{dBi} < 6\text{dBi}$, so Band2 limit=11 dBm/MHz

Directional gain= $G_{ANT}+10\log(N_{ANT}/N_{ss})=3.73\text{dBi} < 6\text{dBi}$, so Band3 limit=11 dBm/MHz

Temperature	23°C	Humidity	63%
Test Engineer	David Tseng	Configurations	IEEE 802.11a
Test Date	Aug. 02, 2013		

Configuration IEEE 802.11a / Chain 2

Channel	Frequency	Total Power Density (dBm/MHz)	Max. Limit (dBm/MHz)	Result
52	5260 MHz	1.50	11.00	Complies
60	5300 MHz	1.09	11.00	Complies
64	5320 MHz	1.34	11.00	Complies
100	5500 MHz	1.70	11.00	Complies
116	5580 MHz	3.51	11.00	Complies
140	5700 MHz	2.16	11.00	Complies

Note: All the test values were listed in the report.

For plots, only the channel with maximum results was shown.

Power Density Plot on Configuration IEEE 802.11ac MCS0/Nss2 20MHz / Chain 1 + Chain 2 / 5320 MHz

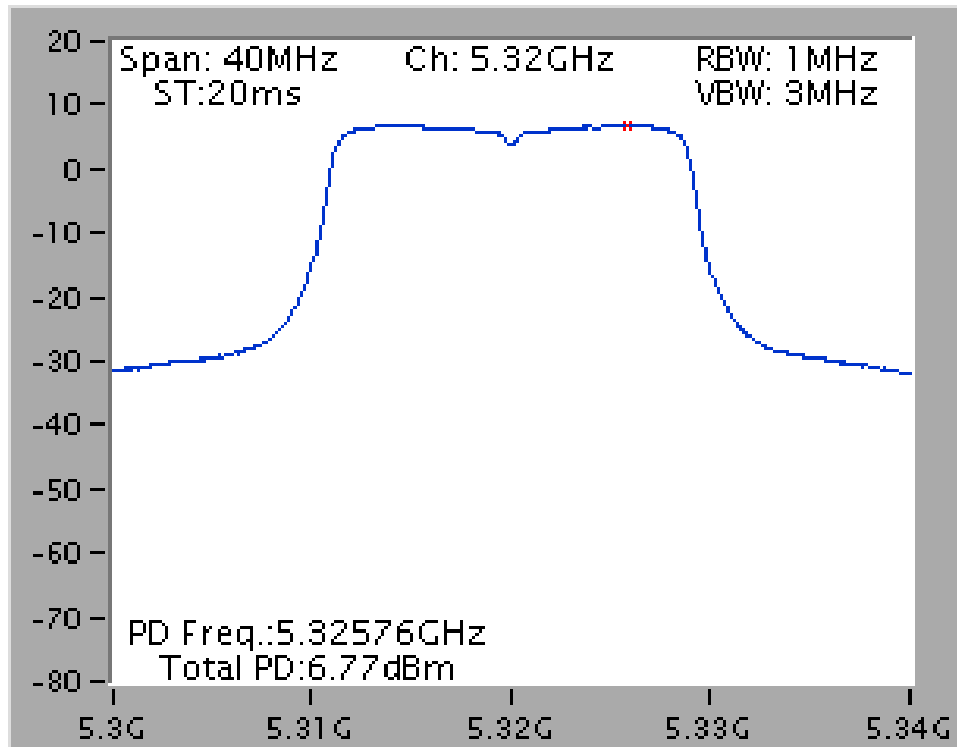

Power Density Plot on Configuration IEEE 802.11ac MCS0/Nss2 20MHz / Chain 1 + Chain 2 / 5580 MHz

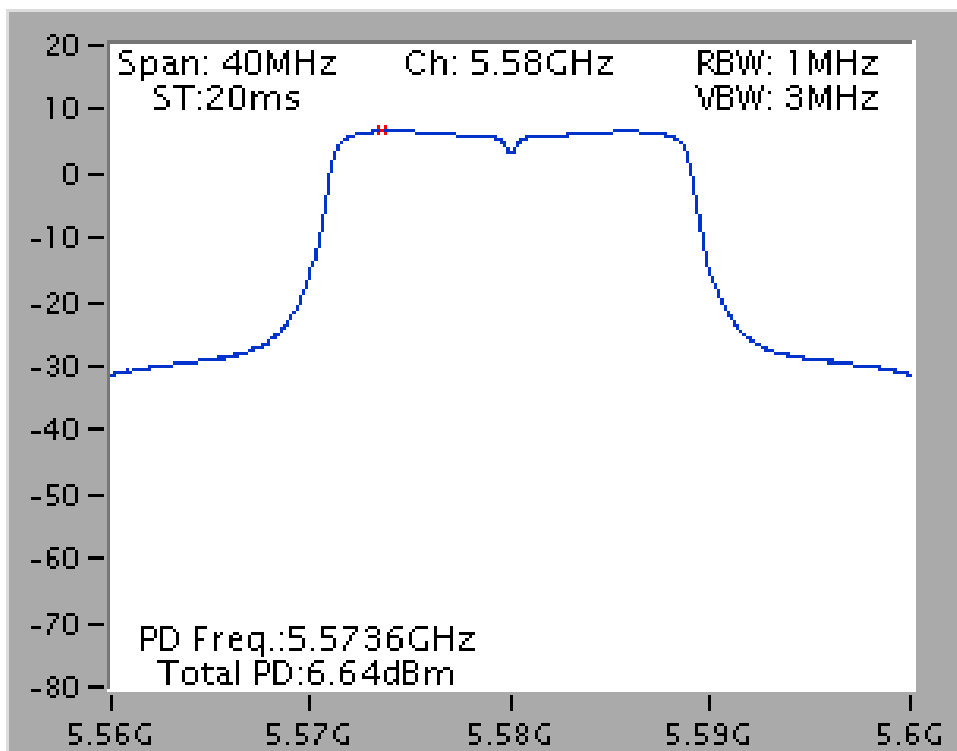

Power Density Plot on Configuration IEEE 802.11ac MCS0/Nss2 40MHz / Chain 1 + Chain 2 / 5270 MHz

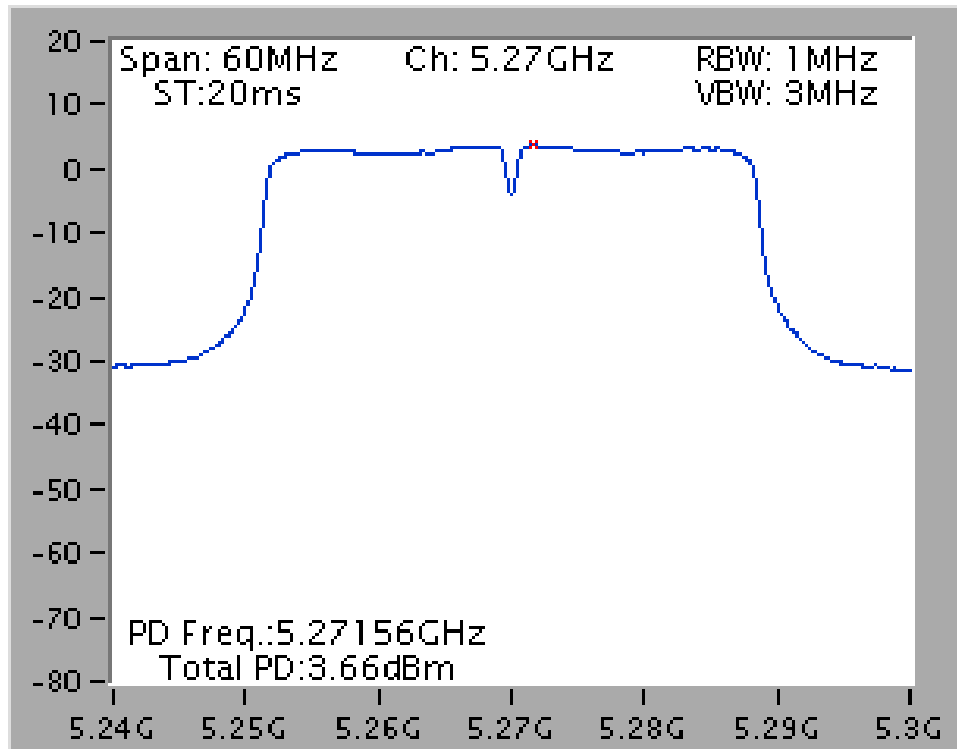

Power Density Plot on Configuration IEEE 802.11ac MCS0/Nss2 40MHz / Chain 1 + Chain 2 / 5550 MHz

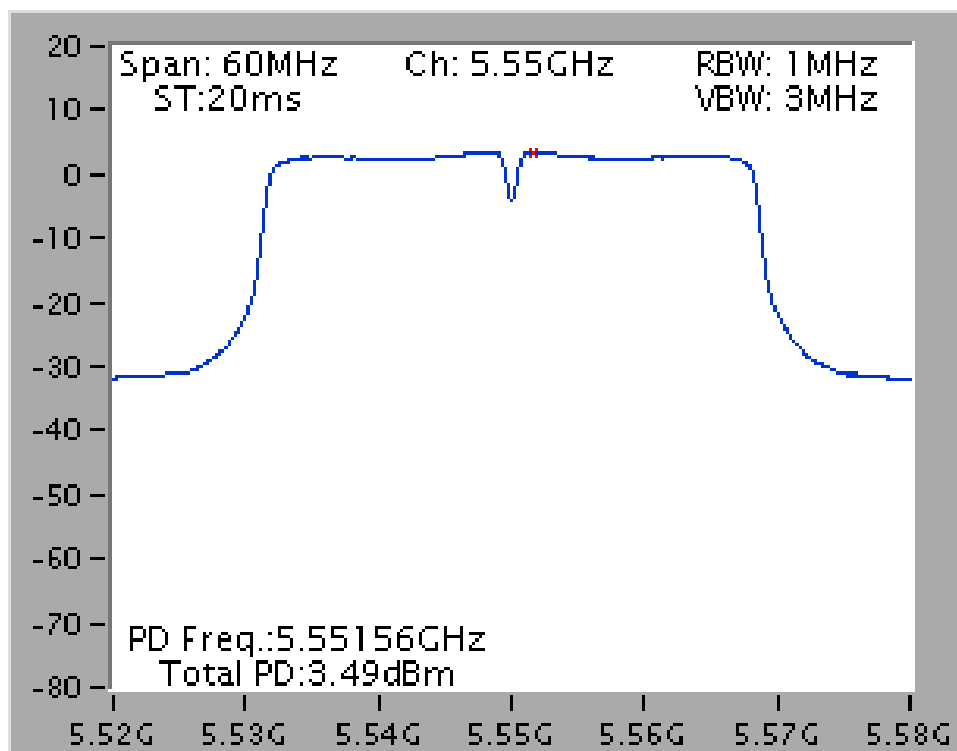

Power Density Plot on Configuration IEEE 802.11ac MCS0/Nss2 80MHz / Chain 1 + Chain 2 / 5290 MHz

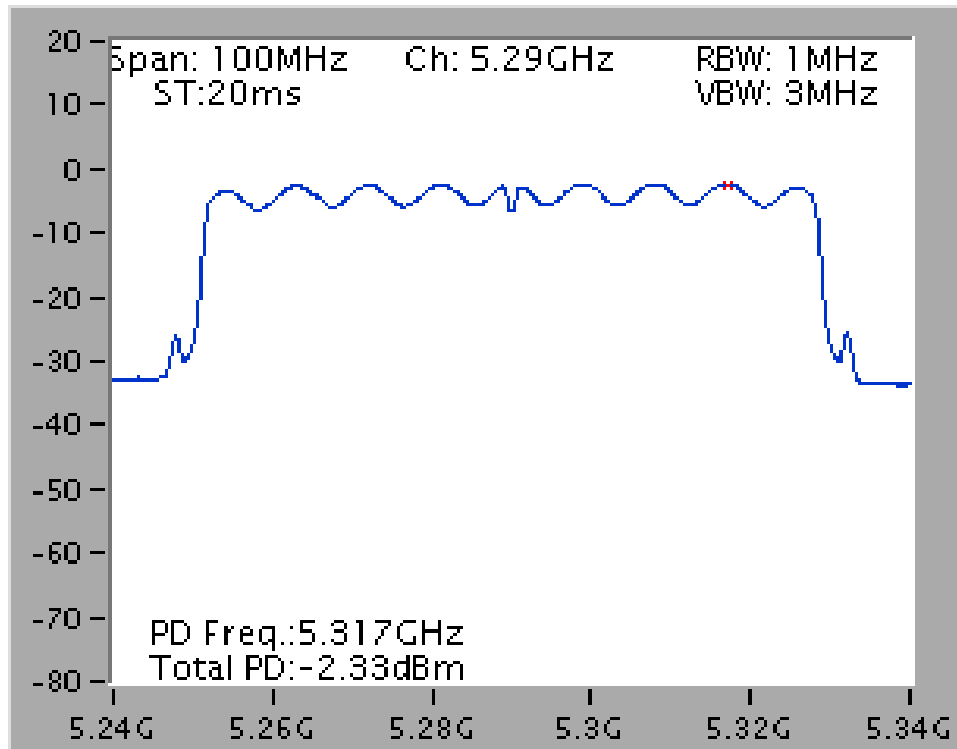

Power Density Plot on Configuration IEEE 802.11ac MCS0/Nss2 80MHz / Chain 1 + Chain 2 / 5530 MHz

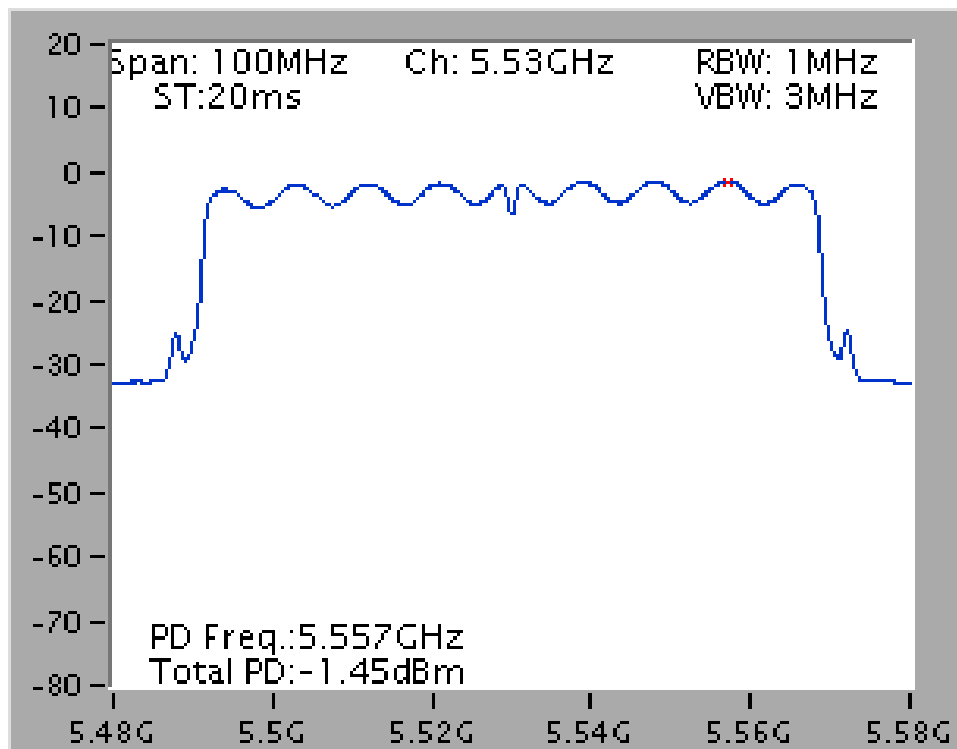

Power Density Plot on Configuration IEEE 802.11a / Chain 2 / 5260 MHz

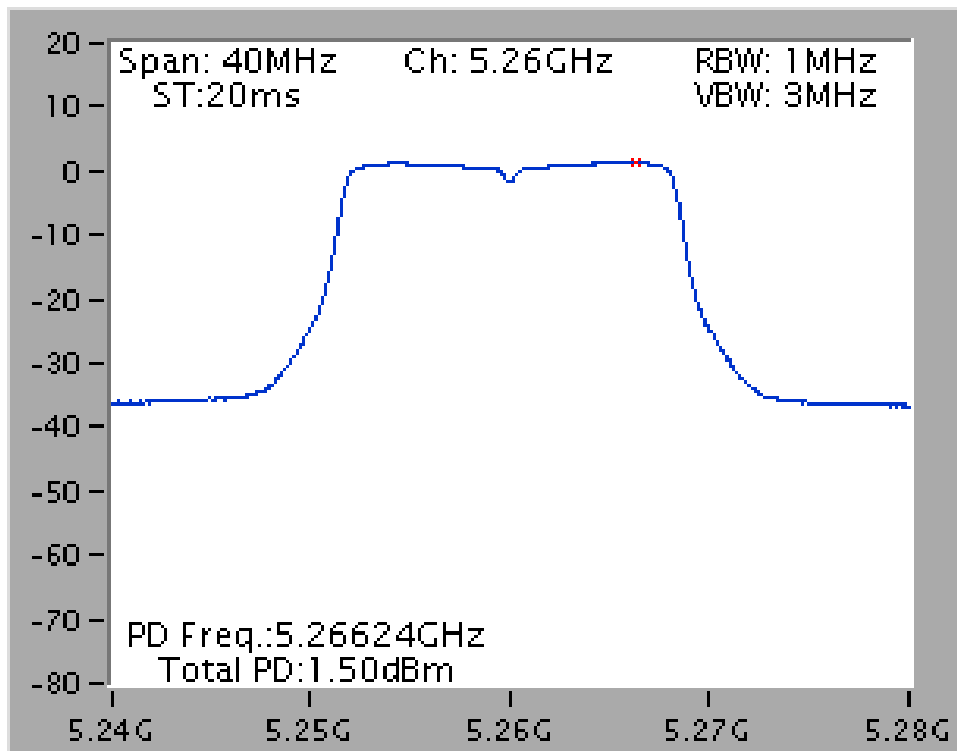

Power Density Plot on Configuration IEEE 802.11a / Chain 2 / 5580 MHz

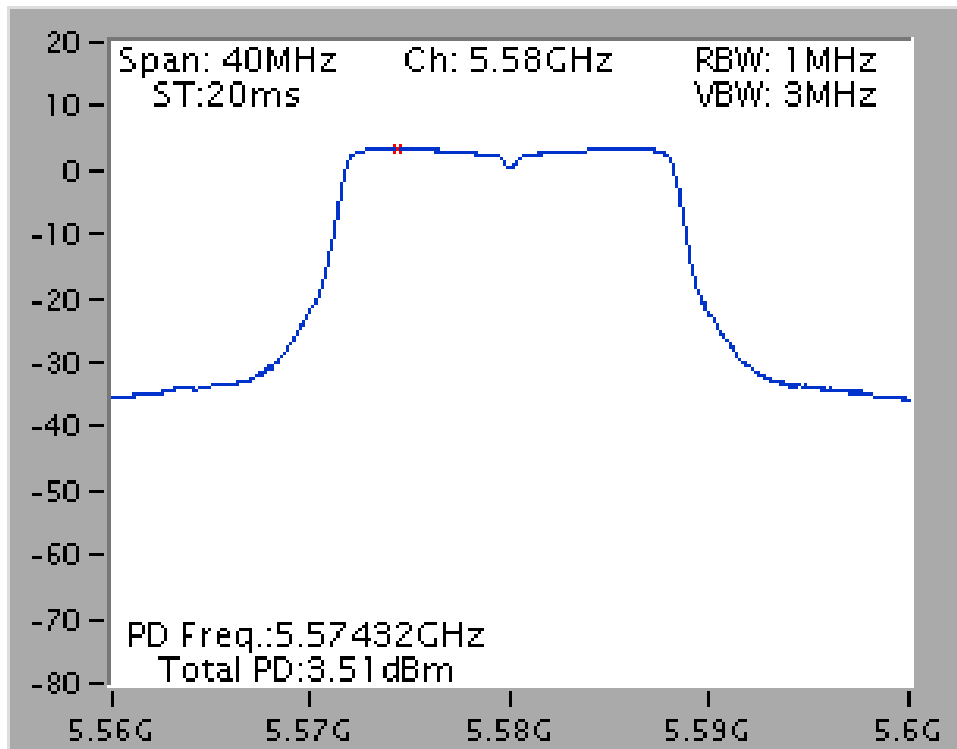

4.5. Peak Excursion Measurement

4.5.1. Limit

The ratio of the peak excursion of the modulation envelope (measured using a peak hold function) to the maximum conducted output power (measured as specified above) shall not exceed 13 dB across any 1 MHz bandwidth or the emissions bandwidth whichever is less.

4.5.2. Measuring Instruments and Setting

Please refer to section 5 of equipments list in this report. The following table is the setting of the spectrum analyzer.

Spectrum Parameter	Setting
Attenuation	Auto
Span Frequency	Encompass the entire emissions bandwidth (EBW) of the signal
RBW	1MHz (Peak Trace) / 1MHz (Average Trace)
VBW	≥ 3 MHz (Peak Trace) / ≥ 3 MHz (Average Trace)
Detector	Peak (Peak Trace) / RMS (Average Trace)
Trace	Trace: Max hold (Peak Trace) / Trace Average Sweep Count 100 (Average Trace)
Sweep Time	AUTO

4.5.3. Test Procedures

1. Trace A, Set RBW =1MHz, VBW = 3MHz, Span >26dB bandwidth, Max. hold.
2. Delta Mark trace A Maximum frequency and trace B same frequency.
3. Repeat the above procedure until measurements for all frequencies were complete.
4. Testing each modulation mode on a single channel in single operating band at single output port. All signal types need test (DSSS, OFDM). All modulation types need test (BPSK, QPSK, 16-QAM, 64-QAM, 256-QAM). All bandwidth modes need test.

4.5.4. Test Setup Layout

This test setup layout is the same as that shown in section 4.4.4.

4.5.5. Test Deviation

There is no deviation with the original standard.

4.5.6. EUT Operation during Test

The EUT was programmed to be in continuously transmitting mode.

4.5.7. Test Result of Peak Excursion

Temperature	23°C	Humidity	63%
Test Engineer	David Tseng	Configurations	IEEE 802.11ac

Configuration IEEE 802.11ac MCS0/Nss2 20MHz / Chain 1 + Chain 2

Modulation	Frequency	Peak Excursion (dB)	Max. Limit (dB)	Result
BSPK(MCS0Nss2)	5260MHz	9.02	13	Complies
QPSK(MCS1Nss2)	5260MHz	9.34	13	Complies
16QAM(MCS3Nss2)	5260MHz	9.33	13	Complies
64QAM(MCS5Nss2)	5260MHz	9.14	13	Complies
256QAM(MCS8Nss2)	5260MHz	8.71	13	Complies
BSPK(MCS0Nss2)	5580MHz	9.30	13	Complies
QPSK(MCS1Nss2)	5580MHz	9.50	13	Complies
16QAM(MCS3Nss2)	5580MHz	9.21	13	Complies
64QAM(MCS5Nss2)	5580MHz	9.31	13	Complies
256QAM(MCS8Nss2)	5580MHz	8.91	13	Complies

Configuration IEEE 802.11ac MCS0/Nss2 40MHz / Chain 1 + Chain 2

Modulation	Frequency	Peak Excursion (dB)	Max. Limit (dB)	Result
BSPK(MCS0Nss2)	5270MHz	9.18	13	Complies
QPSK(MCS1Nss2)	5270MHz	8.81	13	Complies
16QAM(MCS3Nss2)	5270MHz	9.13	13	Complies
64QAM(MCS5Nss2)	5270MHz	9.39	13	Complies
256QAM(MCS8Nss2)	5270MHz	8.63	13	Complies
BSPK(MCS0Nss2)	5670MHz	9.28	13	Complies
QPSK(MCS1Nss2)	5670MHz	9.16	13	Complies
16QAM(MCS3Nss2)	5670MHz	9.61	13	Complies
64QAM(MCS5Nss2)	5670MHz	9.43	13	Complies
256QAM(MCS8Nss2)	5670MHz	9.30	13	Complies

Configuration IEEE 802.11ac MCS0/Nss2 80MHz / Chain 1 + Chain 2

Modulation	Frequency	Peak Excursion (dB)	Max. Limit (dB)	Result
BSPK(MCS0NSS2)	5290MHz	8.55	13	Complies
QPSK(MCS1NSS2)	5290MHz	8.44	13	Complies
16QAM(MCS3NSS2)	5290MHz	9.23	13	Complies
64QAM(MCS5NSS2)	5290MHz	9.03	13	Complies
256QAM(MCS8NSS2)	5290MHz	9.22	13	Complies
BSPK(MCS0NSS2)	5530MHz	8.57	13	Complies
QPSK(MCS1NSS2)	5530MHz	8.53	13	Complies
16QAM(MCS3NSS2)	5530MHz	9.49	13	Complies
64QAM(MCS5NSS2)	5530MHz	9.34	13	Complies
256QAM(MCS8NSS2)	5530MHz	9.38	13	Complies

Temperature	23°C	Humidity	63%
Test Engineer	David Tseng	Configurations	IEEE 802.11a

Configuration IEEE 802.11a / Chain 2

Modulation	Frequency	Peak Excursion (dB)	Max. Limit (dB)	Result
BSPK(6Mbps)	5320MHz	8.39	13	Complies
QPSK(12Mbps)	5320MHz	9.88	13	Complies
16QAM(24Mbps)	5320MHz	9.52	13	Complies
64QAM(48Mbps)	5320MHz	8.97	13	Complies
BSPK(6Mbps)	5580MHz	8.03	13	Complies
QPSK(12Mbps)	5580MHz	9.51	13	Complies
16QAM(24Mbps)	5580MHz	9.38	13	Complies
64QAM(48Mbps)	5580MHz	9.17	13	Complies

Note: Only the channel with maximum results was listed in the report.

Peak Excursion Plot on Configuration IEEE 802.11ac MCS0/Nss2 20MHz / Chain 1 + Chain 2 / QPSK (MCS1Nss2) / 5260 MHz

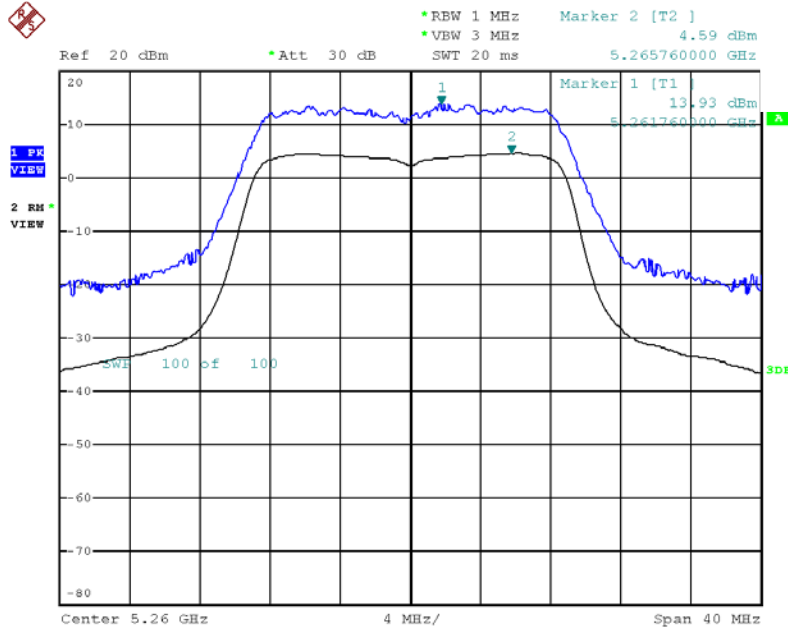

Date: 2.AUG.2013 18:19:03

Peak Excursion Plot on Configuration IEEE 802.11ac MCS0/Nss2 20MHz / Chain 1 + Chain 2 / QPSK (MCS1Nss2) / 5580 MHz

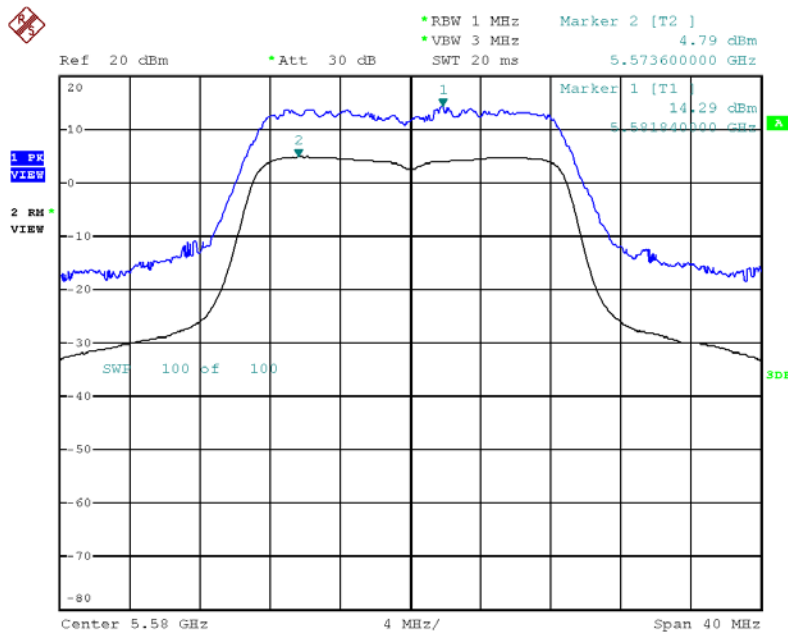

Date: 2.AUG.2013 18:24:27

Peak Excursion Plot on Configuration IEEE 802.11ac MCS0/Nss2 40MHz / Chain 1 + Chain 2 / 64QAM (MCS5Nss2) / 5270 MHz

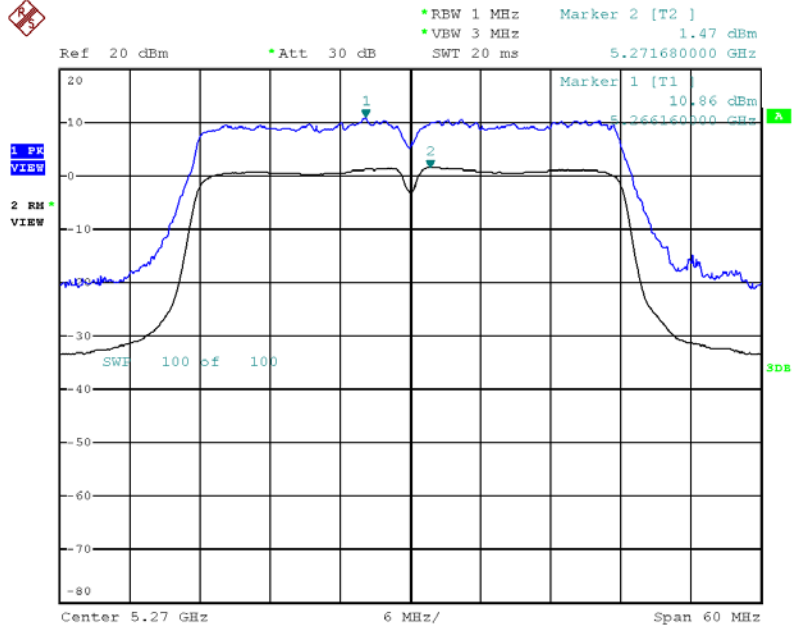

Date: 2.AUG.2013 18:32:14

Peak Excursion Plot on Configuration IEEE 802.11ac MCS0/Nss2 40MHz / Chain 1 + Chain 2 / 16QAM (MCS3Nss2) / 5670 MHz

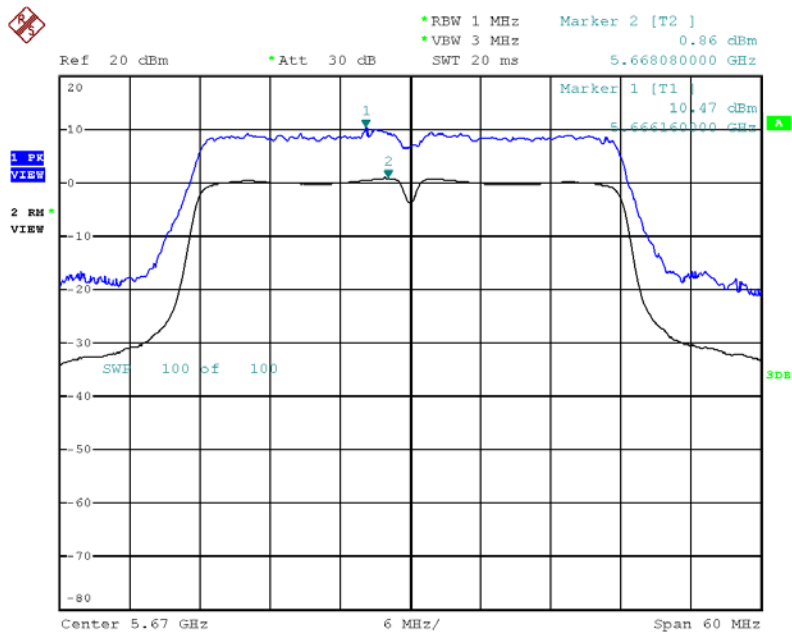

Date: 2.AUG.2013 18:39:19

Peak Excursion Plot on Configuration IEEE 802.11ac MCS0/Nss2 80MHz / Chain 1 + Chain 2 / 16QAM (MCS3Nss2) / 5290 MHz

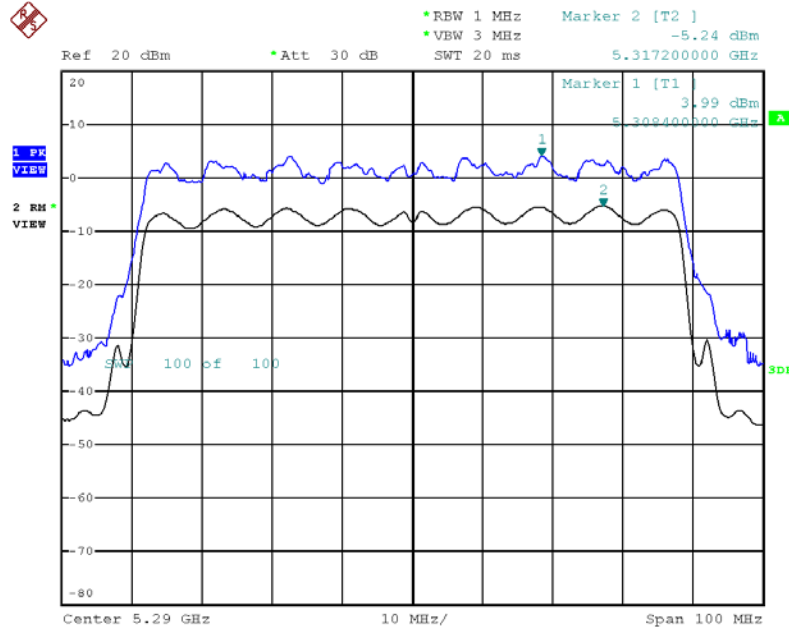

Date: 2.AUG.2013 19:09:26

Peak Excursion Plot on Configuration IEEE 802.11ac MCS0/Nss2 80MHz / Chain 1 + Chain 2 / 16QAM (MCS3Nss2) / 5530 MHz

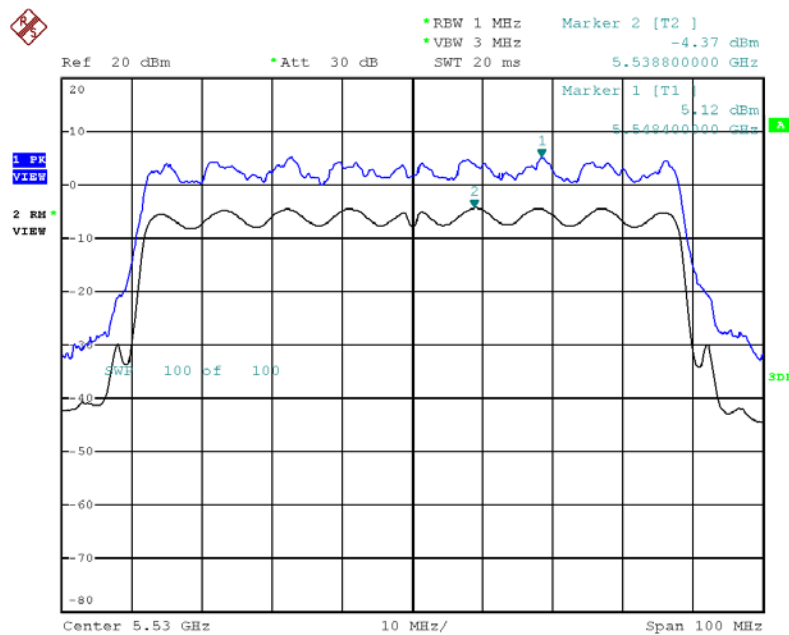

Date: 2.AUG.2013 18:45:56

Peak Excursion Plot on Configuration IEEE 802.11a / Chain 2 / QPSK (12Mbps) / 5320 MHz

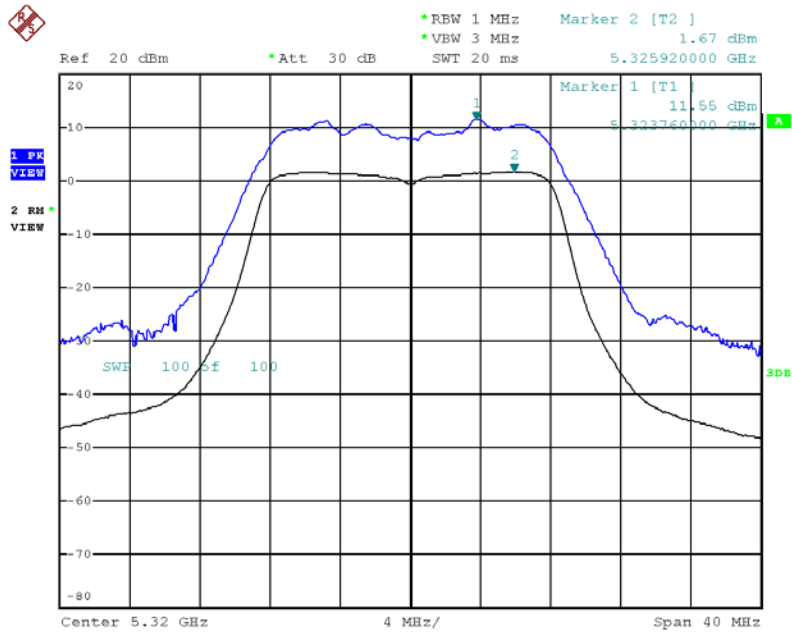

Date: 2.AUG.2013 18:04:24

Peak Excursion Plot on Configuration IEEE 802.11a / Chain 2 / QPSK (12Mbps) / 5580 MHz

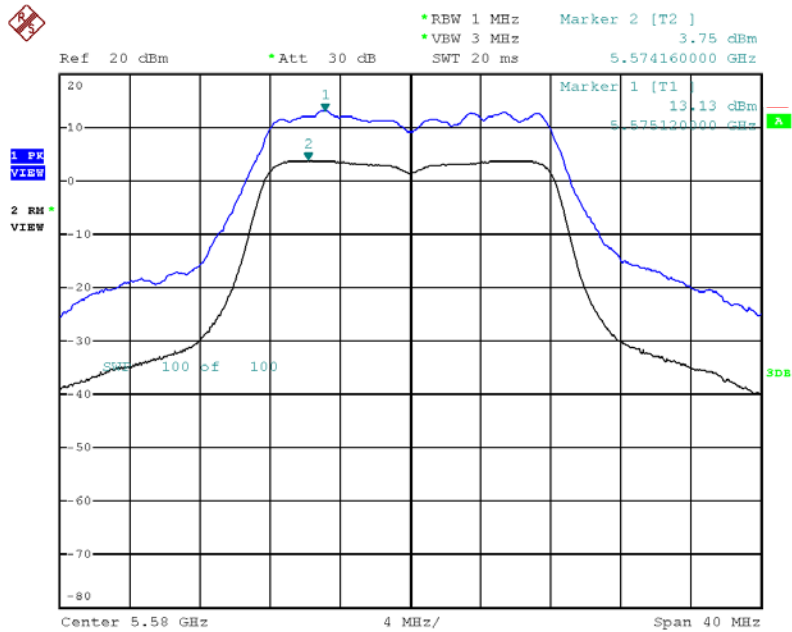

Date: 2.AUG.2013 18:11:08

4.6. Radiated Emissions Measurement

4.6.1. Limit

For transmitters operating in the 5.15-5.35 GHz band: all emissions outside of the 5.15-5.35 GHz band shall not exceed a -27dBm peak limit or average 54dBuV/m and peak 74dBuV/m limits. For transmitters operating in the 5.470-5.725 GHz band: all emissions outside of the 5.470-5.725 GHz band shall not exceed a -27dBm peak limit or average 54dBuV/m and peak 74dBuV/m limits. For transmitters operating in the 5.725-5.825 GHz band: all emissions within the frequency range from the band edge to 10 MHz above or below the band edge shall not exceed an EIRP of -17 dBm/MHz (78.3dBuV/m at 3m). In addition, In case the emission fall within the restricted band specified on 15.205(a), then the 15.209(a) limit in the table below has to be followed.

Frequencies (MHz)	Field Strength (micorvolts/meter)	Measurement Distance (meters)
0.009~0.490	2400/F(kHz)	300
0.490~1.705	24000/F(kHz)	30
1.705~30.0	30	30
30~88	100	3
88~216	150	3
216~960	200	3
Above 960	500	3

4.6.2. Measuring Instruments and Setting

Please refer to section 5 of equipments list in this report. The following table is the setting of spectrum analyzer and receiver.

Spectrum Parameter	Setting
Attenuation	Auto
Start Frequency	1000 MHz
Stop Frequency	40 GHz
RBW / VBW (Emission in restricted band)	1MHz / 3MHz for Peak, 1MHz / 10Hz for Average
RBW / VBW (Emission in non-restricted band)	1MHz / 3MHz for peak

Receiver Parameter	Setting
Attenuation	Auto
Start ~ Stop Frequency	9kHz~150kHz / RBW 200Hz for QP
Start ~ Stop Frequency	150kHz~30MHz / RBW 9kHz for QP
Start ~ Stop Frequency	30MHz~1000MHz / RBW 120kHz for QP

4.6.3. Test Procedures

1. Configure the EUT according to ANSI C63.10. The EUT was placed on the top of the turntable 0.8 meter above ground. The phase center of the receiving antenna mounted on the top of a height-variable antenna tower was placed 3 meters far away from the turntable.
2. Power on the EUT and all the supporting units. The turntable was rotated by 360 degrees to determine the position of the highest radiation.
3. The height of the broadband receiving antenna was varied between one meter and four meters above ground to find the maximum emissions field strength of both horizontal and vertical polarization.
4. For each suspected emissions, the antenna tower was scan (from 1 M to 4 M) and then the turntable was rotated (from 0 degree to 360 degrees) to find the maximum reading.
5. Set the test-receiver system to Peak or CISPR quasi-peak Detect Function with specified bandwidth under Maximum Hold Mode.
6. For emissions above 1GHz, use 1MHz VBW and RBW for peak reading. Then 1MHz RBW and 10Hz VBW for average reading in spectrum analyzer.
7. When the radiated emissions limits are expressed in terms of the average value of the emissions, and pulsed operation is employed, the measurement field strength shall be determined by averaging over one complete pulse train, including blanking intervals, as long as the pulse train does not exceed 0.1 seconds. As an alternative (provided the transmitter operates for longer than 0.1 seconds) or in cases where the pulse train exceeds 0.1 seconds, the measured field strength shall be determined from the average absolute voltage during a 0.1 second interval during which the field strength is at its maximum value.
8. If the emissions level of the EUT in peak mode was 3 dB lower than the average limit specified, then testing will be stopped and peak values of EUT will be reported, otherwise, the emissions which do not have 3 dB margin will be repeated one by one using the quasi-peak method for below 1GHz.
9. For testing above 1GHz, the emissions level of the EUT in peak mode was lower than average limit (that means the emissions level in peak mode also complies with the limit in average mode), then testing will be stopped and peak values of EUT will be reported, otherwise, the emissions will be measured in average mode again and reported.
10. In case the emission is lower than 30MHz, loop antenna has to be used for measurement and the recorded data should be QP measured by receiver. High – Low scan is not required in this case.

4.6.4. Test Setup Layout

For Radiated Emissions: 9kHz ~30MHz

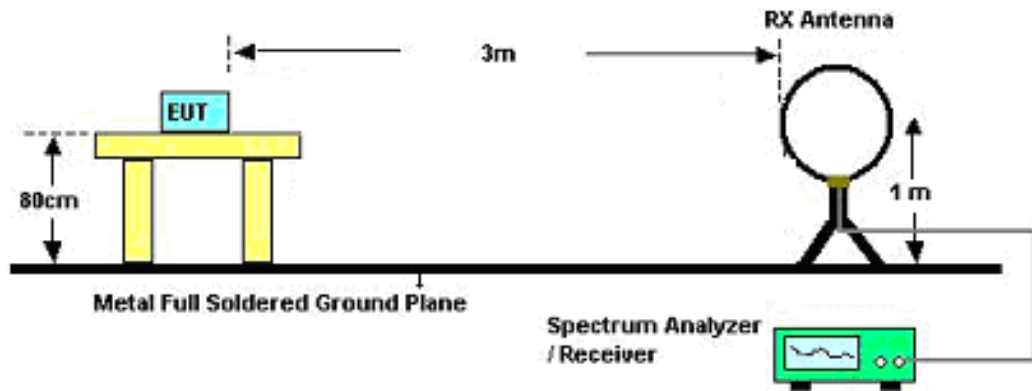

For Radiated Emissions: 30MHz~1GHz

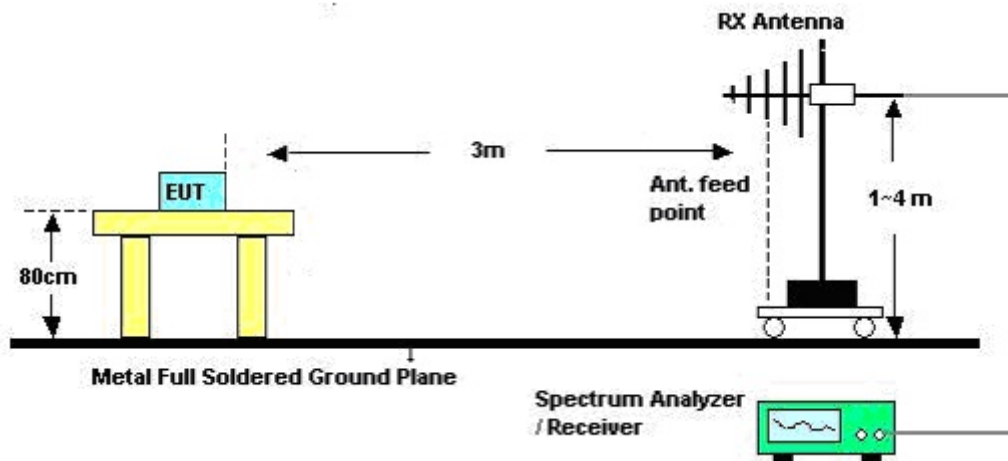

For Radiated Emissions: Above 1GHz

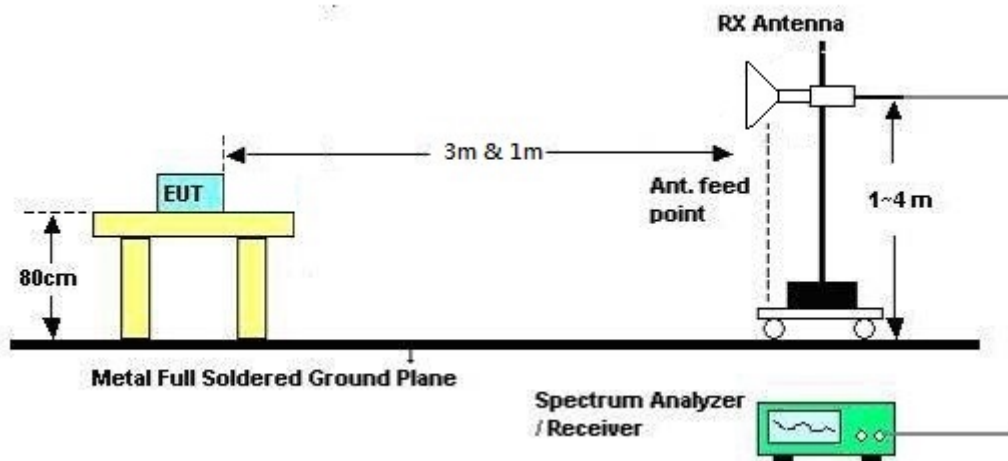

4.6.5. Test Deviation

There is no deviation with the original standard.

4.6.6. EUT Operation during Test

The EUT was programmed to be in continuously transmitting mode.

4.6.7. Results of Radiated Emissions (9kHz~30MHz)

Temperature	26°C	Humidity	60%
Test Engineer	Magic Lai	Configurations	CTX / Mode 2
Test Date	Nov. 23, 2012		

Freq. (MHz)	Level (dBuV)	Over Limit (dB)	Limit Line (dBuV)	Remark
-	-	-	-	See Note

Note:

The amplitude of spurious emissions that are attenuated by more than 20dB below the permissible value has no need to be reported.

Distance extrapolation factor = $40 \log (\text{specific distance} / \text{test distance})$ (dB);

Limit line = specific limits (dBuV) + distance extrapolation factor.

4.6.8. Results of Radiated Emissions (30MHz~1GHz)

Temperature	26°C	Humidity	60%
Test Engineer	Magic Lai	Configurations	CTX / Mode 2

Horizontal

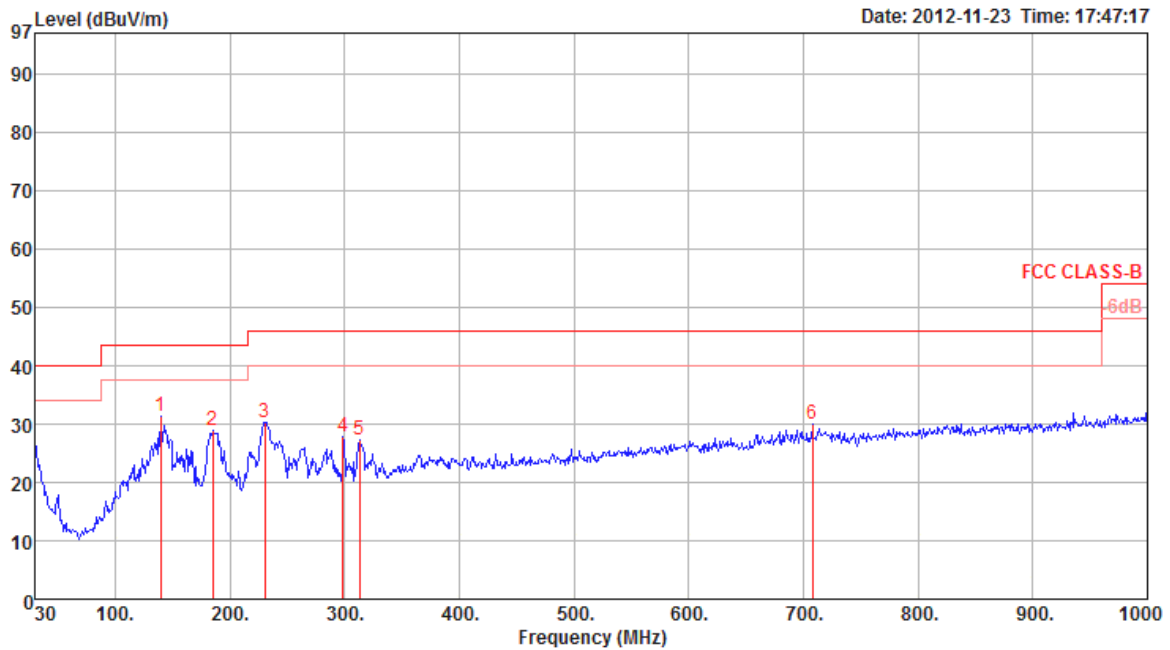

	Freq	Level	Limit	Over	Read	Cable	Preamp	Antenna	Remark	T/Pos	A/Pos	Pol/Phase
	MHz	dBuV/m	dBuV/m	dB	dBuV	dB	dB	dB/m		deg	cm	
1 p	139.61	31.22	43.50	-12.28	44.97	1.71	27.56	12.10	Peak	0	400	HORIZONTAL
2	185.20	28.93	43.50	-14.57	44.40	2.03	27.35	9.85	Peak	0	400	HORIZONTAL
3	230.79	30.28	46.00	-15.72	43.64	2.29	27.03	11.38	Peak	0	400	HORIZONTAL
4	298.69	27.90	46.00	-18.10	38.42	2.51	26.83	13.80	Peak	0	400	HORIZONTAL
5	313.24	27.41	46.00	-18.59	37.50	2.59	26.88	14.20	Peak	0	400	HORIZONTAL
6	708.03	30.12	46.00	-15.88	33.01	4.17	27.09	20.03	Peak	0	400	HORIZONTAL

Vertical

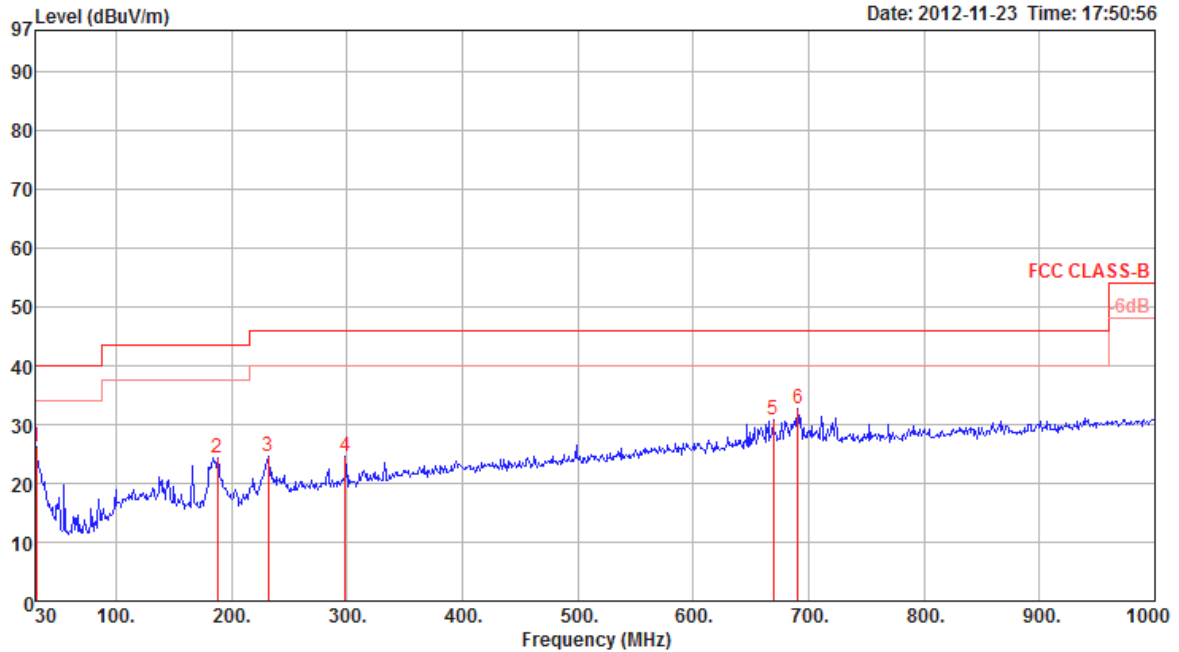

	Freq	Level	Limit Line	Over Limit	Read Level	Cable Loss	Preamp Factor	Antenna Factor	Remark	T/Pos	A/Pos	Pol/Phase
	MHz	dBuV/m	dBuV/m	dB	dBuV	dB	dB	dB/m		deg	cm	
1	30.97	26.18	40.00	-13.82	34.01	0.85	27.98	19.30	Peak	0	100	VERTICAL
2	188.11	24.23	43.50	-19.27	39.70	2.04	27.33	9.82	Peak	0	100	VERTICAL
3	231.76	24.51	46.00	-21.49	37.78	2.29	27.02	11.46	Peak	0	100	VERTICAL
4	298.69	24.50	46.00	-21.50	35.02	2.51	26.83	13.80	Peak	0	100	VERTICAL
5	669.23	30.92	46.00	-15.08	34.55	4.00	27.38	19.75	Peak	0	100	VERTICAL
6 p	690.57	32.79	46.00	-13.21	35.93	4.11	27.17	19.92	Peak	0	100	VERTICAL

Note:

The amplitude of spurious emissions that are attenuated by more than 20dB below the permissible value has no need to be reported.

Emission level (dBuV/m) = 20 log Emission level (uV/m).

Corrected Reading: Antenna Factor + Cable Loss + Read Level - Preamp Factor = Level.

4.6.9. Results for Radiated Emissions (1GHz~40GHz)

Temperature	24.5°C	Humidity	57%
Test Engineer	Jim Huang	Configurations	IEEE 802.11ac MCS0/Nss2 20MHz Ch52 / Chain 1 + Chain 2 / Mode 2
Test Date	Aug. 01, 2013		

Horizontal

	Freq	Level	Limit Line	Over Limit	Read Level	CableAntenna Loss	Antenna Factor	Preamp Factor	Remark	A/Pos	T/Pos	Pol/Phase
	MHz	dBuV/m	dBuV/m	dB	dBuV	dB	dB/m	dB		cm	deg	
1	15775.08	57.85	74.00	-16.15	44.82	10.80	37.77	35.54	Peak	100	222	HORIZONTAL
2	15781.72	44.43	54.00	-9.57	31.42	10.80	37.75	35.54	Average	100	222	HORIZONTAL

Vertical

	Freq	Level	Limit Line	Over Limit	Read Level	CableAntenna Loss	Antenna Factor	Preamp Factor	Remark	A/Pos	T/Pos	Pol/Phase
	MHz	dBuV/m	dBuV/m	dB	dBuV	dB	dB/m	dB		cm	deg	
1	15785.04	56.74	74.00	-17.26	43.73	10.80	37.75	35.54	Peak	100	148	VERTICAL
2	15789.64	44.36	54.00	-9.64	31.35	10.80	37.75	35.54	Average	100	148	VERTICAL



Temperature	24.5°C	Humidity	57%
Test Engineer	Jim Huang	Configurations	IEEE 802.11ac MCS0/Nss2 20MHz Ch60 / Chain 1 + Chain 2 / Mode 2
Test Date	Aug. 01, 2013		

Horizontal

	Freq	Level	Limit Line	Over Limit	Read Level	CableAntenna Loss	Antenna Factor	Preamp Factor	Remark	A/Pos	T/Pos	Pol/Phase
	MHz	dBuV/m	dBuV/m	dB	dBuV	dB	dB/m	dB		cm	deg	
1	10607.64	40.27	54.00	-13.73	26.85	8.64	39.90	35.12	Average	100	289	HORIZONTAL
2	10608.92	52.84	74.00	-21.16	39.42	8.64	39.90	35.12	Peak	100	289	HORIZONTAL
3	15895.80	57.06	74.00	-16.94	44.21	10.81	37.56	35.52	Peak	100	306	HORIZONTAL
4	15907.68	43.06	54.00	-10.94	30.21	10.81	37.56	35.52	Average	100	306	HORIZONTAL

Vertical

	Freq	Level	Limit Line	Over Limit	Read Level	CableAntenna Loss	Antenna Factor	Preamp Factor	Remark	A/Pos	T/Pos	Pol/Phase
	MHz	dBuV/m	dBuV/m	dB	dBuV	dB	dB/m	dB		cm	deg	
1	10607.64	40.27	54.00	-13.73	26.85	8.64	39.90	35.12	Average	100	277	VERTICAL
2	10607.64	51.04	74.00	-22.96	37.62	8.64	39.90	35.12	Peak	100	277	VERTICAL
3	15890.00	56.24	74.00	-17.76	43.36	10.81	37.59	35.52	Peak	100	208	VERTICAL
4	15891.40	43.62	54.00	-10.38	30.74	10.81	37.59	35.52	Average	100	208	VERTICAL



Temperature	24.5°C	Humidity	57%
Test Engineer	Jim Huang	Configurations	IEEE 802.11ac MCS0/Nss2 20MHz Ch64 / Chain 1 + Chain 2 / Mode 2
Test Date	Aug. 01, 2013		

Horizontal

	Freq	Level	Limit	Over	Read	CableAntenna	Preamp	Remark	A/Pos	T/Pos	Pol/Phase	
	MHz	dBuV/m	dBuV/m	dB	dBuV	dB	dB/m	dB	cm	deg		
1	10634.80	52.90	74.00	-21.10	39.47	8.66	39.86	35.09	Peak	100	239	HORIZONTAL
2	10640.04	40.69	54.00	-13.31	27.26	8.66	39.86	35.09	Average	100	239	HORIZONTAL
3	15956.56	43.38	54.00	-10.62	30.59	10.82	37.48	35.51	Average	100	213	HORIZONTAL
4	15959.20	55.66	74.00	-18.34	42.87	10.82	37.48	35.51	Peak	100	213	HORIZONTAL

Vertical

	Freq	Level	Limit	Over	Read	CableAntenna	Preamp	Remark	A/Pos	T/Pos	Pol/Phase	
	MHz	dBuV/m	dBuV/m	dB	dBuV	dB	dB/m	dB	cm	deg		
1	10639.84	40.95	54.00	-13.05	27.52	8.66	39.86	35.09	Average	100	141	VERTICAL
2	10645.44	53.89	74.00	-20.11	40.46	8.66	39.86	35.09	Peak	100	141	VERTICAL
3	15950.32	43.63	54.00	-10.37	30.85	10.81	37.48	35.51	Average	100	199	VERTICAL
4	15961.80	55.54	74.00	-18.46	42.75	10.82	37.48	35.51	Peak	100	199	VERTICAL



Temperature	24.5°C	Humidity	57%
Test Engineer	Jim Huang	Configurations	IEEE 802.11ac MCS0/Nss2 20MHz Ch100 / Chain 1 + Chain 2 / Mode 2
Test Date	Aug. 01, 2013		

Horizontal

	Freq	Level	Limit	Over	Read	CableAntenna	Preamp	Remark	A/Pos	T/Pos	Pol/Phase
	MHz	dBuV/m	dBuV/m	dB	dBuV	dB	dB/m	dB	cm	deg	
1	10995.96	40.78	54.00	-13.22	27.15	8.93	39.50	34.80	Average	100	279 HORIZONTAL
2	11005.24	54.01	74.00	-19.99	40.37	8.94	39.50	34.80	Peak	100	279 HORIZONTAL

Vertical

	Freq	Level	Limit	Over	Read	CableAntenna	Preamp	Remark	A/Pos	T/Pos	Pol/Phase
	MHz	dBuV/m	dBuV/m	dB	dBuV	dB	dB/m	dB	cm	deg	
1	10992.72	40.83	54.00	-13.17	27.20	8.93	39.50	34.80	Average	100	222 VERTICAL
2	11000.04	54.18	74.00	-19.82	40.55	8.93	39.50	34.80	Peak	100	222 VERTICAL



Temperature	24.5°C	Humidity	57%
Test Engineer	Jim Huang	Configurations	IEEE 802.11ac MCS0/Nss2 20MHz Ch116 / Chain 1 + Chain 2 / Mode 2
Test Date	Aug. 01, 2013		

Horizontal

	Freq	Level	Limit	Over	Read	CableAntenna	Preamp		A/Pos	T/Pos	Pol/Phase	
	MHz	dBuV/m	dBuV/m	dB	dBuV	Loss	Factor	Factor	Remark	cm	deg	
1	11160.04	41.54	54.00	-12.46	27.89	9.04	39.50	34.89	Average	100	209	HORIZONTAL
2	11169.52	53.54	74.00	-20.46	39.90	9.04	39.50	34.90	Peak	100	209	HORIZONTAL

Vertical

	Freq	Level	Limit	Over	Read	CableAntenna	Preamp		A/Pos	T/Pos	Pol/Phase	
	MHz	dBuV/m	dBuV/m	dB	dBuV	Loss	Factor	Factor	Remark	cm	deg	
1	11157.84	53.39	74.00	-20.61	39.74	9.04	39.50	34.89	Peak	100	127	VERTICAL
2	11159.92	40.96	54.00	-13.04	27.31	9.04	39.50	34.89	Average	100	127	VERTICAL



Temperature	24.5°C	Humidity	57%
Test Engineer	Jim Huang	Configurations	IEEE 802.11ac MCS0/Nss2 20MHz Ch140 / Chain 1 + Chain 2 / Mode 2
Test Date	Aug. 01, 2013		

Horizontal

	Freq	Level	Limit	Over	Read	CableAntenna	Preamp	Remark	A/Pos	T/Pos	Pol/Phase
	MHz	dBuV/m	dBuV/m	dB	dBuV	dB	dB/m	dB	cm	deg	
1	11395.08	54.51	74.00	-19.49	40.87	9.18	39.50	35.04	Peak	100	327 HORIZONTAL
2	11402.52	41.49	54.00	-12.51	27.84	9.19	39.50	35.04	Average	100	327 HORIZONTAL

Vertical

	Freq	Level	Limit	Over	Read	CableAntenna	Preamp	Remark	A/Pos	T/Pos	Pol/Phase
	MHz	dBuV/m	dBuV/m	dB	dBuV	dB	dB/m	dB	cm	deg	
1	11400.12	41.88	54.00	-12.12	28.23	9.19	39.50	35.04	Average	100	276 VERTICAL
2	11402.20	54.21	74.00	-19.79	40.56	9.19	39.50	35.04	Peak	100	276 VERTICAL

Temperature	24.5°C	Humidity	57%
Test Engineer	Jim Huang	Configurations	IEEE 802.11ac MCS0/Nss2 40MHz Ch54 / Chain 1 + Chain 2 / Mode 2
Test Date	Aug. 01, 2013		

Horizontal

	Freq	Level	Limit Line	Over Limit	Read Level	CableAntenna Loss	Antenna Factor	Preamp Factor	Remark	A/Pos	T/Pos	Pol/Phase
	MHz	dBuV/m	dBuV/m	dB	dBuV	dB	dB/m	dB		cm	deg	
1	15804.00	56.08	74.00	-17.92	43.10	10.80	37.72	35.54	Peak	100	275	HORIZONTAL
2	15810.32	44.07	54.00	-9.93	31.09	10.80	37.72	35.54	Average	100	275	HORIZONTAL

Vertical

	Freq	Level	Limit Line	Over Limit	Read Level	CableAntenna Loss	Antenna Factor	Preamp Factor	Remark	A/Pos	T/Pos	Pol/Phase
	MHz	dBuV/m	dBuV/m	dB	dBuV	dB	dB/m	dB		cm	deg	
1	15802.12	56.47	74.00	-17.53	43.49	10.80	37.72	35.54	Peak	100	275	VERTICAL
2	15803.16	44.23	54.00	-9.77	31.25	10.80	37.72	35.54	Average	100	275	VERTICAL



Temperature	24.5°C	Humidity	57%
Test Engineer	Jim Huang	Configurations	IEEE 802.11ac MCS0/Nss2 40MHz Ch62 / Chain 1 + Chain 2 / Mode 2
Test Date	Aug. 01, 2013		

Horizontal

	Freq	Level	Limit	Over	Read	CableAntenna	Preamp	Remark	A/Pos	T/Pos	Pol/Phase
	MHz	dBuV/m	dBuV/m	dB	dBuV	dB	dB/m	dB	cm	deg	
1	10611.40	52.68	74.00	-21.32	39.26	8.64	39.90	35.12	Peak	100	319 HORIZONTAL
2	10620.96	40.62	54.00	-13.38	27.21	8.65	39.88	35.12	Average	100	319 HORIZONTAL
3	15928.08	43.96	54.00	-10.04	31.13	10.81	37.53	35.51	Average	100	242 HORIZONTAL
4	15930.44	56.66	74.00	-17.34	43.85	10.81	37.51	35.51	Peak	100	242 HORIZONTAL

Vertical

	Freq	Level	Limit	Over	Read	CableAntenna	Preamp	Remark	A/Pos	T/Pos	Pol/Phase
	MHz	dBuV/m	dBuV/m	dB	dBuV	dB	dB/m	dB	cm	deg	
1	10617.44	53.28	74.00	-20.72	39.87	8.65	39.88	35.12	Peak	100	228 VERTICAL
2	10620.36	40.52	54.00	-13.48	27.11	8.65	39.88	35.12	Average	100	228 VERTICAL
3	15927.80	56.46	74.00	-17.54	43.63	10.81	37.53	35.51	Peak	100	187 VERTICAL
4	15937.88	43.92	54.00	-10.08	31.11	10.81	37.51	35.51	Average	100	187 VERTICAL



Temperature	24.5°C	Humidity	57%
Test Engineer	Jim Huang	Configurations	IEEE 802.11ac MCS0/Nss2 40MHz Ch102 / Chain 1 + Chain 2 / Mode 2
Test Date	Aug. 01, 2013		

Horizontal

	Freq	Level	Limit	Over	Read	CableAntenna	Preamp	Remark	A/Pos	T/Pos	Pol/Phase
	MHz	dBuV/m	dBuV/m	dB	dBuV	dB	dB/m	dB	cm	deg	
1	11016.92	52.71	74.00	-21.29	39.08	8.94	39.50	34.81	Peak	100	252 HORIZONTAL
2	11020.04	40.53	54.00	-13.47	26.90	8.94	39.50	34.81	Average	100	252 HORIZONTAL

Vertical

	Freq	Level	Limit	Over	Read	CableAntenna	Preamp	Remark	A/Pos	T/Pos	Pol/Phase
	MHz	dBuV/m	dBuV/m	dB	dBuV	dB	dB/m	dB	cm	deg	
1	11012.52	52.96	74.00	-21.04	39.33	8.94	39.50	34.81	Peak	100	202 VERTICAL
2	11020.12	41.14	54.00	-12.86	27.51	8.94	39.50	34.81	Average	100	202 VERTICAL



Temperature	24.5°C	Humidity	57%
Test Engineer	Jim Huang	Configurations	IEEE 802.11ac MCS0/Nss2 40MHz Ch110 / Chain 1 + Chain 2 / Mode 2
Test Date	Aug. 01, 2013		

Horizontal

	Freq	Level	Limit	Over	Read	CableAntenna	Preamp	Remark	A/Pos	T/Pos	Pol/Phase
	MHz	dBuV/m	dBuV/m	dB	dBuV	dB	dB/m	dB	cm	deg	
1	11111.88	41.13	54.00	-12.87	27.49	9.00	39.50	34.86	Average	100	156 HORIZONTAL
2	11118.20	53.61	74.00	-20.39	39.99	9.00	39.50	34.88	Peak	100	156 HORIZONTAL

Vertical

	Freq	Level	Limit	Over	Read	CableAntenna	Preamp	Remark	A/Pos	T/Pos	Pol/Phase
	MHz	dBuV/m	dBuV/m	dB	dBuV	dB	dB/m	dB	cm	deg	
1	11111.60	53.04	74.00	-20.96	39.40	9.00	39.50	34.86	Peak	100	212 VERTICAL
2	11111.64	41.27	54.00	-12.73	27.63	9.00	39.50	34.86	Average	100	212 VERTICAL



Temperature	24.5°C	Humidity	57%
Test Engineer	Jim Huang	Configurations	IEEE 802.11ac MCS0/Nss2 40MHz Ch134 / Chain 1 + Chain 2 / Mode 2
Test Date	Aug. 01, 2013		

Horizontal

	Freq	Level	Limit	Over	Read	CableAntenna	Preamp	Remark	A/Pos	T/Pos	Pol/Phase
	MHz	dBuV/m	dBuV/m	dB	dBuV	dB	dB/m	dB	cm	deg	
1	11340.04	40.46	54.00	-13.54	26.81	9.14	39.50	34.99	Average	100	253 HORIZONTAL
2	11341.04	53.14	74.00	-20.86	39.49	9.14	39.50	34.99	Peak	100	253 HORIZONTAL

Vertical

	Freq	Level	Limit	Over	Read	CableAntenna	Preamp	Remark	A/Pos	T/Pos	Pol/Phase
	MHz	dBuV/m	dBuV/m	dB	dBuV	dB	dB/m	dB	cm	deg	
1	11340.12	40.52	54.00	-13.48	26.87	9.14	39.50	34.99	Average	100	186 VERTICAL
2	11348.32	52.89	74.00	-21.11	39.25	9.15	39.50	35.01	Peak	100	186 VERTICAL



Temperature	24.5°C	Humidity	57%
Test Engineer	Jim Huang	Configurations	IEEE 802.11ac MCS0/Nss2 80MHz Ch58 / Chain 1 + Chain 2 / Mode 2
Test Date	Aug. 01, 2013		

Horizontal

	Freq	Level	Limit	Over	Read	CableAntenna	Preamp	Remark	A/Pos	T/Pos	Pol/Phase
	MHz	dBuV/m	dBuV/m	dB	dBuV	dB	dB/m	dB	cm	deg	
1	15872.68	44.37	54.00	-9.63	31.48	10.81	37.61	35.53 Average	100	188	HORIZONTAL
2	15878.52	57.21	74.00	-16.79	44.34	10.81	37.59	35.53 Peak	100	188	HORIZONTAL

Vertical

	Freq	Level	Limit	Over	Read	CableAntenna	Preamp	Remark	A/Pos	T/Pos	Pol/Phase
	MHz	dBuV/m	dBuV/m	dB	dBuV	dB	dB/m	dB	cm	deg	
1	15864.16	56.79	74.00	-17.21	43.90	10.81	37.61	35.53 Peak	100	298	VERTICAL
2	15868.68	44.34	54.00	-9.66	31.45	10.81	37.61	35.53 Average	100	298	VERTICAL



Temperature	24.5°C	Humidity	57%
Test Engineer	Jim Huang	Configurations	IEEE 802.11ac MCS0/Nss2 80MHz Ch106 / Chain 1 + Chain 2 / Mode 2
Test Date	Aug. 01, 2013		

Horizontal

	Freq	Level	Limit	Over	Read	Cable	Antenna	Preamp	Remark	A/Pos	T/Pos	Pol/Phase
	MHz	dBuV/m	dBuV/m	dB	dBuV	dB	dB/m	dB		cm	deg	
1	11060.08	41.69	54.00	-12.31	28.05	8.97	39.50	34.83	Average	100	104	HORIZONTAL
2	11060.16	53.47	74.00	-20.53	39.83	8.97	39.50	34.83	Peak	100	104	HORIZONTAL

Vertical

	Freq	Level	Limit	Over	Read	Cable	Antenna	Preamp	Remark	A/Pos	T/Pos	Pol/Phase
	MHz	dBuV/m	dBuV/m	dB	dBuV	dB	dB/m	dB		cm	deg	
1	11060.16	41.51	54.00	-12.49	27.87	8.97	39.50	34.83	Average	100	162	VERTICAL
2	11060.56	53.69	74.00	-20.31	40.05	8.97	39.50	34.83	Peak	100	162	VERTICAL

Note:

The amplitude of spurious emissions that are attenuated by more than 20dB below the permissible value has no need to be reported.

Emission level (dBuV/m) = 20 log Emission level (uV/m).

Corrected Reading: Antenna Factor + Cable Loss + Read Level - Preamp Factor = Level.



Temperature	24.5°C	Humidity	57%
Test Engineer	Jim Huang	Configurations	IEEE 802.11a Ch52 / Chain 2 / Mode 2
Test Date	Aug. 01, 2013		

Horizontal

	Freq	Level	Limit	Over	Read	CableAntenna	Preamp	Remark	A/Pos	T/Pos	Pol/Phase
	MHz	dBuV/m	dBuV/m	dB	dBuV	dB	dB/m	dB	cm	deg	
1	15771.84	57.18	74.00	-16.82	44.15	10.80	37.77	35.54	Peak	100	96 HORIZONTAL
2	15778.52	44.60	54.00	-9.40	31.59	10.80	37.75	35.54	Average	100	96 HORIZONTAL

Vertical

	Freq	Level	Limit	Over	Read	CableAntenna	Preamp	Remark	A/Pos	T/Pos	Pol/Phase
	MHz	dBuV/m	dBuV/m	dB	dBuV	dB	dB/m	dB	cm	deg	
1	15785.92	43.27	54.00	-10.73	30.26	10.80	37.75	35.54	Average	100	66 VERTICAL
2	15789.60	57.68	74.00	-16.32	44.67	10.80	37.75	35.54	Peak	100	66 VERTICAL



Temperature	24.5°C	Humidity	57%
Test Engineer	Jim Huang	Configurations	IEEE 802.11a Ch60 / Chain 2 / Mode 2
Test Date	Aug. 01, 2013		

Horizontal

	Freq	Level	Limit	Over	Read	CableAntenna	Preamp		A/Pos	T/Pos	Pol/Phase
	MHz	dBuV/m	dBuV/m	dB	dBuV	dB	dB/m	dB	cm	deg	
1	10601.28	53.18	74.00	-20.82	39.78	8.64	39.90	35.14	100	230	HORIZONTAL
2	10601.48	40.76	54.00	-13.24	27.34	8.64	39.90	35.12	100	230	HORIZONTAL
3	15890.36	44.01	54.00	-9.99	31.13	10.81	37.59	35.52	100	147	HORIZONTAL
4	15903.28	56.95	74.00	-17.05	44.10	10.81	37.56	35.52	100	145	HORIZONTAL

Vertical

	Freq	Level	Limit	Over	Read	CableAntenna	Preamp		A/Pos	T/Pos	Pol/Phase
	MHz	dBuV/m	dBuV/m	dB	dBuV	dB	dB/m	dB	cm	deg	
1	10600.44	40.86	54.00	-13.14	27.46	8.64	39.90	35.14	100	155	VERTICAL
2	10600.44	51.37	74.00	-22.63	37.97	8.64	39.90	35.14	100	155	VERTICAL
3	15891.48	44.27	54.00	-9.73	31.39	10.81	37.59	35.52	100	220	VERTICAL
4	15895.64	56.44	74.00	-17.56	43.59	10.81	37.56	35.52	100	220	VERTICAL



Temperature	24.5°C	Humidity	57%
Test Engineer	Jim Huang	Configurations	IEEE 802.11a Ch64 / Chain 2 / Mode 2
Test Date	Aug. 01, 2013		

Horizontal

	Freq	Level	Limit	Over	Read	CableAntenna	Preamp		A/Pos	T/Pos	Pol/Phase
	MHz	dBuV/m	dBuV/m	dB	dBuV	dB	dB/m	dB	cm	deg	
1	10644.44	40.29	54.00	-13.71	26.86	8.66	39.86	35.09	100	159	HORIZONTAL
2	10644.44	58.18	74.00	-15.82	44.75	8.66	39.86	35.09	100	159	HORIZONTAL
3	15951.00	56.13	74.00	-17.87	43.35	10.81	37.48	35.51	100	159	HORIZONTAL
4	15951.12	43.81	54.00	-10.19	31.03	10.81	37.48	35.51	100	159	HORIZONTAL

Vertical

	Freq	Level	Limit	Over	Read	CableAntenna	Preamp		A/Pos	T/Pos	Pol/Phase
	MHz	dBuV/m	dBuV/m	dB	dBuV	dB	dB/m	dB	cm	deg	
1	10633.76	53.07	74.00	-20.93	39.64	8.66	39.86	35.09	100	180	VERTICAL
2	10639.88	41.73	54.00	-12.27	28.30	8.66	39.86	35.09	100	180	VERTICAL
3	15959.80	56.95	74.00	-17.05	44.16	10.82	37.48	35.51	100	210	VERTICAL
4	15964.12	44.12	54.00	-9.88	31.36	10.82	37.45	35.51	100	210	VERTICAL



Temperature	24.5°C	Humidity	57%
Test Engineer	Jim Huang	Configurations	IEEE 802.11a Ch100 / Chain 2 / Mode 2
Test Date	Aug. 01, 2013		

Horizontal

	Freq	Level	Limit	Over	Read	CableAntenna	Preamp		A/Pos	T/Pos	Pol/Phase
	MHz	dBuV/m	dBuV/m	dB	dBuV	Loss	Factor	Factor	cm	deg	
1	10998.04	53.40	74.00	-20.60	39.77	8.93	39.50	34.80	100	123	HORIZONTAL
2	11000.04	41.36	54.00	-12.64	27.73	8.93	39.50	34.80	100	123	HORIZONTAL

Vertical

	Freq	Level	Limit	Over	Read	CableAntenna	Preamp		A/Pos	T/Pos	Pol/Phase
	MHz	dBuV/m	dBuV/m	dB	dBuV	Loss	Factor	Factor	cm	deg	
1	11004.68	53.76	74.00	-20.24	40.12	8.94	39.50	34.80	100	164	VERTICAL
2	11005.80	41.18	54.00	-12.82	27.54	8.94	39.50	34.80	100	164	VERTICAL



Temperature	24.5°C	Humidity	57%
Test Engineer	Jim Huang	Configurations	IEEE 802.11a Ch116 / Chain 2 / Mode 2
Test Date	Aug. 01, 2013		

Horizontal

	Freq	Level	Limit Line	Over Limit	Read Level	CableAntenna Loss	Antenna Factor	Preamp Factor	Remark	A/Pos	T/Pos	Pol/Phase
	MHz	dBuV/m	dBuV/m	dB	dBuV	dB	dB/m	dB		cm	deg	
1	11152.76	53.73	74.00	-20.27	40.09	9.03	39.50	34.89	Peak	100	168	HORIZONTAL
2	11163.44	40.84	54.00	-13.16	27.20	9.04	39.50	34.90	Average	100	168	HORIZONTAL

Vertical

	Freq	Level	Limit Line	Over Limit	Read Level	CableAntenna Loss	Antenna Factor	Preamp Factor	Remark	A/Pos	T/Pos	Pol/Phase
	MHz	dBuV/m	dBuV/m	dB	dBuV	dB	dB/m	dB		cm	deg	
1	11159.20	53.44	74.00	-20.56	39.79	9.04	39.50	34.89	Peak	100	166	VERTICAL
2	11159.92	41.41	54.00	-12.59	27.76	9.04	39.50	34.89	Average	100	166	VERTICAL



Temperature	24.5°C	Humidity	57%
Test Engineer	Jim Huang	Configurations	IEEE 802.11a Ch140 / Chain 2 / Mode 2
Test Date	Aug. 01, 2013		

Horizontal

	Freq	Level	Limit Line	Over Limit	Read Level	CableAntenna Loss	Antenna Factor	Preamp Factor	Remark	A/Pos	T/Pos	Pol/Phase
	MHz	dBuV/m	dBuV/m	dB	dBuV	dB	dB/m	dB		cm	deg	
1	11390.40	53.84	74.00	-20.16	40.18	9.18	39.50	35.02	Peak	100	189	HORIZONTAL
2	11399.92	42.88	54.00	-11.12	29.23	9.19	39.50	35.04	Average	100	189	HORIZONTAL

Vertical

	Freq	Level	Limit Line	Over Limit	Read Level	CableAntenna Loss	Antenna Factor	Preamp Factor	Remark	A/Pos	T/Pos	Pol/Phase
	MHz	dBuV/m	dBuV/m	dB	dBuV	dB	dB/m	dB		cm	deg	
1	11400.04	41.54	54.00	-12.46	27.89	9.19	39.50	35.04	Average	100	152	VERTICAL
2	11401.64	54.95	74.00	-19.05	41.30	9.19	39.50	35.04	Peak	100	152	VERTICAL

Note:

The amplitude of spurious emissions that are attenuated by more than 20dB below the permissible value has no need to be reported.

Emission level (dBuV/m) = 20 log Emission level (uV/m).

Corrected Reading: Antenna Factor + Cable Loss + Read Level - Preamp Factor = Level.

4.7. Band Edge Emissions Measurement

4.7.1. Limit

For transmitters operating in the 5.15-5.35 GHz band: all emissions outside of the 5.15-5.35 GHz band shall not exceed a -27dBm peak limit or average 54dBuV/m and peak 74dBuV/m limits. For transmitters operating in the 5.470-5.725 GHz band: all emissions outside of the 5.470-5.725 GHz band shall not exceed a -27dBm peak limit or average 54dBuV/m and peak 74dBuV/m limits. For transmitters operating in the 5.725-5.825 GHz band: all emissions within the frequency range from the band edge to 10 MHz above or below the band edge shall not exceed an EIRP of -17 dBm/MHz (78.3dBuV/m at 3m). In addition, In case the emission fall within the restricted band specified on 15.205(a), then the 15.209(a) limit in the table below has to be followed.

Frequencies (MHz)	Field Strength (micorvolts/meter)	Measurement Distance (meters)
0.009~0.490	2400/F(kHz)	300
0.490~1.705	24000/F(kHz)	30
1.705~30.0	30	30
30~88	100	3
88~216	150	3
216~960	200	3
Above 960	500	3

4.7.2. Measuring Instruments and Setting

Please refer to section 5 of equipments list in this report. The following table is the setting of the spectrum analyzer.

Spectrum Parameter	Setting
Attenuation	Auto
Span Frequency	100 MHz
RBW / VBW (Emission in restricted band)	1MHz / 3MHz for Peak, 1MHz / 10Hz for Average
RBW / VBW (Emission in non-restricted band)	1MHz / 3MHz for Peak

4.7.3. Test Procedures

1. The test procedure is the same as section 4.6.3, only the frequency range investigated is limited to 100MHz around bandedges.

4.7.4. Test Setup Layout

This test setup layout is the same as that shown in section 4.6.4.

4.7.5. Test Deviation

There is no deviation with the original standard.

4.7.6. EUT Operation during Test

The EUT was programmed to be in continuously transmitting mode.

4.7.7. Test Result of Band Edge and Fundamental Emissions

Temperature	24.5°C	Humidity	57%
Test Engineer	Jim Huang	Configurations	IEEE 802.11ac MCS0/Nss2 20MHz Ch 52,60, 64 / Chain 1 + Chain 2
Test Date	Aug. 01, 2013		

Channel 52

	Freq	Level	Limit	Over	Read	CableAntenna	Preamp	Remark	A/Pos	T/Pos	Pol/Phase
	MHz	dBuV/m	dBuV/m	dB	dBuV	dB	dB/m	dB	cm	deg	
1	5266.40	115.98			75.52	6.21	34.25	0.00 Peak	100	279	VERTICAL
2	5266.80	105.92			65.46	6.21	34.25	0.00 Average	100	279	VERTICAL
3	5360.00	44.96	54.00	-9.04	4.28	6.26	34.42	0.00 Average	100	279	VERTICAL
4	5360.00	56.53	74.00	-17.47	15.85	6.26	34.42	0.00 Peak	100	279	VERTICAL

Item 1, 2 are the fundamental frequency at 5260 MHz.

Channel 60

	Freq	Level	Limit	Over	Read	CableAntenna	Preamp	Remark	A/Pos	T/Pos	Pol/Phase
	MHz	dBuV/m	dBuV/m	dB	dBuV	dB	dB/m	dB	cm	deg	
1	5297.60	103.90			63.35	6.23	34.32	0.00 Average	100	90	VERTICAL
2	5302.40	115.65			75.10	6.23	34.32	0.00 Peak	100	90	VERTICAL
3	5350.00	44.68	54.00	-9.32	4.00	6.26	34.42	0.00 Average	100	90	VERTICAL
4	5350.00	56.28	74.00	-17.72	15.60	6.26	34.42	0.00 Peak	100	90	VERTICAL

Item 1, 2 are the fundamental frequency at 5300 MHz.

Channel 64

	Freq	Level	Limit	Over	Read	CableAntenna	Preamp	Remark	A/Pos	T/Pos	Pol/Phase
	MHz	dBuV/m	dBuV/m	dB	dBuV	dB	dB/m	dB	cm	deg	
1	5314.60	114.32			73.72	6.24	34.36	0.00 Peak	102	326	VERTICAL
2	5322.20	103.21			62.61	6.24	34.36	0.00 Average	102	326	VERTICAL
3	5350.00	47.15	54.00	-6.85	6.47	6.26	34.42	0.00 Average	102	326	VERTICAL
4	5350.00	60.71	74.00	-13.29	20.03	6.26	34.42	0.00 Peak	102	326	VERTICAL

Item 1, 2 are the fundamental frequency at 5320 MHz.



Temperature	24.5°C	Humidity	57%
Test Engineer	Jim Huang	Configurations	IEEE 802.11ac MCS0/Nss2 20MHz Ch 100,140 / Chain 1 + Chain 2
Test Date	Aug. 01, 2013		

Channel 100

	Freq	Level	Limit	Over	Read	CableAntenna	Preamp	Remark	A/Pos	T/Pos	Pol/Phase
	MHz	dBuV/m	dBuV/m	dB	dBuV	dB	dB/m	dB	cm	deg	
1	5460.00	46.51	54.00	-7.49	5.55	6.33	34.63	0.00 Average	100	86	VERTICAL
2	5460.00	60.69	74.00	-13.31	19.73	6.33	34.63	0.00 Peak	100	86	VERTICAL
3	5469.80	65.32	74.00	-8.68	24.31	6.34	34.67	0.00 Peak	100	86	VERTICAL
4	5470.00	49.74	54.00	-4.26	8.73	6.34	34.67	0.00 Average	100	86	VERTICAL
5	5502.60	115.41			74.34	6.36	34.71	0.00 Peak	100	86	VERTICAL
6	5504.60	103.53			62.46	6.36	34.71	0.00 Average	100	86	VERTICAL

Item 5, 6 are the fundamental frequency at 5500 MHz.

Channel 140

	Freq	Level	Limit	Over	Read	CableAntenna	Preamp	Remark	A/Pos	T/Pos	Pol/Phase
	MHz	dBuV/m	dBuV/m	dB	dBuV	dB	dB/m	dB	cm	deg	
1	5702.60	113.73			72.43	6.44	34.86	0.00 Peak	100	140	VERTICAL
2	5704.60	101.93			60.63	6.44	34.86	0.00 Average	100	140	VERTICAL
3	5725.00	52.16	54.00	-1.84	10.82	6.45	34.89	0.00 Average	100	140	VERTICAL
4	5725.20	66.70	74.00	-7.30	25.36	6.45	34.89	0.00 Peak	100	140	VERTICAL

Item 1, 2 are the fundamental frequency at 5700 MHz.

Temperature	24.5°C	Humidity	57%
Test Engineer	Jim Huang	Configurations	IEEE 802.11ac MCS0/Nss2 40MHz Ch 54,62 / Chain 1 + Chain 2
Test Date	Aug. 01, 2013		

Channel 54

	Freq	Level	Limit	Over	Read	CableAntenna	Preamp	Remark	A/Pos	T/Pos	Pol/Phase
	MHz	dBuV/m	dBuV/m	dB	dBuV	dB	dB/m	dB	cm	deg	
1	5273.20	101.20			60.74	6.21	34.25	0.00 Average	100	280	VERTICAL
2	5284.00	111.15			70.64	6.22	34.29	0.00 Peak	100	280	VERTICAL
3	5350.00	45.72	54.00	-8.28	5.04	6.26	34.42	0.00 Average	100	280	VERTICAL
4	5354.40	58.10	74.00	-15.90	17.42	6.26	34.42	0.00 Peak	100	280	VERTICAL

Item 1, 2 are the fundamental frequency at 5270 MHz.

Channel 62

	Freq	Level	Limit	Over	Read	CableAntenna	Preamp	Remark	A/Pos	T/Pos	Pol/Phase
	MHz	dBuV/m	dBuV/m	dB	dBuV	dB	dB/m	dB	cm	deg	
1	5304.80	108.97			68.42	6.23	34.32	0.00 Peak	101	97	VERTICAL
2	5308.40	97.84			57.29	6.23	34.32	0.00 Average	101	97	VERTICAL
3	5350.00	52.41	54.00	-1.59	11.73	6.26	34.42	0.00 Average	101	97	VERTICAL
4	5350.40	65.34	74.00	-8.66	24.66	6.26	34.42	0.00 Peak	101	97	VERTICAL

Item 3, 4 are the fundamental frequency at 5310 MHz.



Temperature	24.5°C	Humidity	57%
Test Engineer	Jim Huang	Configurations	IEEE 802.11ac MCS0/Nss2 40MHz Ch 102,110, 134 / Chain 1 + Chain 2
Test Date	Aug. 01, 2013		

Channel 102

	Freq	Level	Limit	Over	Read	CableAntenna	Preamp	Remark	A/Pos	T/Pos	Pol/Phase
	MHz	dBuV/m	dBuV/m	dB	dBuV	dB	dB/m	dB	cm	deg	
1	5459.20	59.36	74.00	-14.64	18.40	6.33	34.63	0.00	100	290	VERTICAL
2	5460.00	47.81	54.00	-6.19	6.85	6.33	34.63	0.00	100	290	VERTICAL
3	5470.00	52.65	54.00	-1.35	11.64	6.34	34.67	0.00	100	290	VERTICAL
4	5470.00	67.13	74.00	-6.87	26.12	6.34	34.67	0.00	100	290	VERTICAL
5	5502.00	98.86			57.79	6.36	34.71	0.00	100	290	VERTICAL
6	5508.80	108.36			67.29	6.36	34.71	0.00	100	290	VERTICAL

Item 5, 6 are the fundamental frequency at 5510 MHz.

Channel 110

	Freq	Level	Limit	Over	Read	CableAntenna	Preamp	Remark	A/Pos	T/Pos	Pol/Phase
	MHz	dBuV/m	dBuV/m	dB	dBuV	dB	dB/m	dB	cm	deg	
1	5458.80	57.41	74.00	-16.59	16.45	6.33	34.63	0.00	111	276	VERTICAL
2	5460.00	46.16	54.00	-7.84	5.20	6.33	34.63	0.00	111	276	VERTICAL
3	5470.00	46.76	54.00	-7.24	5.75	6.34	34.67	0.00	111	276	VERTICAL
4	5470.00	59.05	74.00	-14.95	18.04	6.34	34.67	0.00	111	276	VERTICAL
5	5546.40	102.07			60.96	6.37	34.74	0.00	111	276	VERTICAL
6	5546.80	111.72			70.61	6.37	34.74	0.00	111	276	VERTICAL

Item 5, 6 are the fundamental frequency at 5550 MHz.

Channel 134

	Freq	Level	Limit	Over	Read	CableAntenna	Preamp	Remark	A/Pos	T/Pos	Pol/Phase
	MHz	dBuV/m	dBuV/m	dB	dBuV	dB	dB/m	dB	cm	deg	
1	5666.40	97.99			56.74	6.42	34.83	0.00	100	141	VERTICAL
2	5671.20	109.12			67.86	6.43	34.83	0.00	100	141	VERTICAL
3	5725.00	45.99	54.00	-8.01	4.65	6.45	34.89	0.00	100	141	VERTICAL
4	5726.60	58.25	74.00	-15.75	16.91	6.45	34.89	0.00	100	141	VERTICAL

Item 1, 2 are the fundamental frequency at 5670 MHz.



Temperature	24.5°C	Humidity	57%
Test Engineer	Jim Huang	Configurations	IEEE 802.11ac MCS0/Nss2 80MHz Ch 58,106 / Chain 1 + Chain 2
Test Date	Aug. 01, 2013		

Channel 58

	Freq	Level	Limit	Over	Read	CableAntenna	Preamp		A/Pos	T/Pos	Pol/Phase
	MHz	dBuV/m	dBuV/m	dB	dBuV	dB	dB/m	dB	cm	deg	
1	5146.80	53.52	74.00	-20.48	13.38	6.13	34.01	0.00	100	89	VERTICAL
2	5150.00	42.01	54.00	-11.99	1.87	6.13	34.01	0.00	100	89	VERTICAL
3	5298.00	93.80			53.25	6.23	34.32	0.00	100	89	VERTICAL
4	5298.80	104.60			64.05	6.23	34.32	0.00	100	89	VERTICAL
5	5350.00	56.09			15.41	6.26	34.42	0.00	100	89	VERTICAL
6	5350.00	52.44	54.00	-1.56	11.76	6.26	34.42	0.00	100	89	VERTICAL
7	5350.80	64.37	74.00	-9.63	23.69	6.26	34.42	0.00	100	89	VERTICAL

Item 3, 4, 5 are the fundamental frequency at 5290 MHz.

Channel 106

	Freq	Level	Limit	Over	Read	CableAntenna	Preamp		A/Pos	T/Pos	Pol/Phase
	MHz	dBuV/m	dBuV/m	dB	dBuV	dB	dB/m	dB	cm	deg	
1	5460.00	51.83	54.00	-2.17	10.87	6.33	34.63	0.00	111	277	VERTICAL
2	5460.00	63.08	74.00	-10.92	22.12	6.33	34.63	0.00	111	277	VERTICAL
3	5468.40	65.76	74.00	-8.24	24.75	6.34	34.67	0.00	111	277	VERTICAL
4	5470.00	52.94	54.00	-1.06	11.93	6.34	34.67	0.00	111	277	VERTICAL
5	5502.80	94.96			53.89	6.36	34.71	0.00	111	277	VERTICAL
6	5502.80	104.69			63.62	6.36	34.71	0.00	111	277	VERTICAL

Item 5, 6 are the fundamental frequency at 5530 MHz.

Note:

Emission level (dBuV/m) = 20 log Emission level (uV/m)

Corrected Reading: Antenna Factor + Cable Loss + Read Level - Preamp Factor = Level

Temperature	24.5°C	Humidity	57%
Test Engineer	Jim Huang	Configurations	IEEE 802.11a Ch 52,60, 64 / Chain 2
Test Date	Jul. 24, 2013		

Channel 52

	Freq	Level	Limit	Over	Read	CableAntenna	Preamp	Remark	A/Pos	T/Pos	Pol/Phase
	MHz	dBuV/m	dBuV/m	dB	dBuV	dB	dB/m	dB	cm	deg	
1	5252.95	119.86			79.44	6.20	34.22	0.00 Peak	103	266	VERTICAL
2	5254.87	109.30			68.88	6.20	34.22	0.00 Average	103	266	VERTICAL
3	5350.00	49.00	54.00	-5.00	8.32	6.26	34.42	0.00 Average	103	266	VERTICAL
4	5350.00	62.57	74.00	-11.43	21.89	6.26	34.42	0.00 Peak	103	266	VERTICAL

Item 1, 2 are the fundamental frequency at 5260 MHz.

Channel 60

	Freq	Level	Limit	Over	Read	CableAntenna	Preamp	Remark	A/Pos	T/Pos	Pol/Phase
	MHz	dBuV/m	dBuV/m	dB	dBuV	dB	dB/m	dB	cm	deg	
1	5293.59	118.26			77.74	6.23	34.29	0.00 Peak	102	265	VERTICAL
2	5306.09	108.16			67.61	6.23	34.32	0.00 Average	102	265	VERTICAL
3	5350.00	52.65	54.00	-1.35	11.97	6.26	34.42	0.00 Average	102	265	VERTICAL
4	5350.00	66.89	74.00	-7.11	26.21	6.26	34.42	0.00 Peak	102	265	VERTICAL

Item 1, 2 are the fundamental frequency at 5300 MHz.

Channel 64

	Freq	Level	Limit	Over	Read	CableAntenna	Preamp	Remark	A/Pos	T/Pos	Pol/Phase
	MHz	dBuV/m	dBuV/m	dB	dBuV	dB	dB/m	dB	cm	deg	
1	5313.59	113.88			73.32	6.24	34.32	0.00 Peak	102	266	VERTICAL
2	5315.03	104.19			63.59	6.24	34.36	0.00 Average	102	266	VERTICAL
3	5350.00	52.14	54.00	-1.86	11.46	6.26	34.42	0.00 Average	102	266	VERTICAL
4	5350.00	66.46	74.00	-7.54	25.78	6.26	34.42	0.00 Peak	102	266	VERTICAL

Item 1, 2 are the fundamental frequency at 5320 MHz.



Temperature	24.5°C	Humidity	57%
Test Engineer	Jim Huang	Configurations	IEEE 802.11a Ch 100,140 / Chain 2
Test Date	Jul. 24, 2013		

Channel 100

	Freq	Level	Limit Line	Over Limit	Read Level	Cable Loss	Antenna Factor	Preamp Factor	Remark	A/Pos	T/Pos	Pol/Phase
	MHz	dBuV/m	dBuV/m	dB	dBuV	dB	dB/m	dB		cm	deg	
1	5460.00	47.52	54.00	-6.48	6.56	6.33	34.63	0.00	Average	101	271	VERTICAL
2	5460.00	61.68	74.00	-12.32	20.72	6.33	34.63	0.00	Peak	101	271	VERTICAL
3	5466.80	66.59	74.00	-7.41	25.62	6.34	34.63	0.00	Peak	101	271	VERTICAL
4	5470.00	51.21	54.00	-2.79	10.20	6.34	34.67	0.00	Average	101	271	VERTICAL
5	5493.59	114.69			73.64	6.35	34.70	0.00	Peak	101	271	VERTICAL
6	5505.93	105.28			64.21	6.36	34.71	0.00	Average	101	271	VERTICAL

Item 5, 6 are the fundamental frequency at 5500 MHz.

Channel 140

	Freq	Level	Limit Line	Over Limit	Read Level	Cable Loss	Antenna Factor	Preamp Factor	Remark	A/Pos	T/Pos	Pol/Phase
	MHz	dBuV/m	dBuV/m	dB	dBuV	dB	dB/m	dB		cm	deg	
1	5705.45	112.69			71.39	6.44	34.86	0.00	Peak	117	265	VERTICAL
2	5706.25	103.47			62.16	6.44	34.87	0.00	Average	117	265	VERTICAL
3	5725.00	52.72	54.00	-1.28	11.38	6.45	34.89	0.00	Average	117	265	VERTICAL
4	5728.05	66.77	74.00	-7.23	25.43	6.45	34.89	0.00	Peak	117	265	VERTICAL

Item 1, 2 are the fundamental frequency at 5700 MHz.

Note:

Emission level (dBuV/m) = 20 log Emission level (uV/m)

Corrected Reading: Antenna Factor + Cable Loss + Read Level - Preamp Factor = Level

4.8. Frequency Stability Measurement

4.8.1. Limit

In-band emission is maintained within the band of operation under all conditions of normal operation as specified in the user's manual.

The transmitter center frequency tolerance shall be ± 20 ppm maximum for the 5 GHz band (IEEE 802.11n specification).

4.8.2. Measuring Instruments and Setting

Please refer to section 5 of equipments list in this report. The following table is the setting of the spectrum analyzer.

Spectrum Parameter	Setting
Attenuation	Auto
Span Frequency	Entire absence of modulation emissions bandwidth
RBW	10 kHz
VBW	10 kHz
Sweep Time	Auto

4.8.3. Test Procedures

1. The transmitter output (antenna port) was connected to the spectrum analyzer.
2. EUT have transmitted absence of modulation signal and fixed channelize.
3. Set the spectrum analyzer span to view the entire absence of modulation emissions bandwidth.
4. Set RBW = 10 kHz, VBW = 10 kHz with peak detector and maxhold settings.
5. f_c is declaring of channel frequency. Then the frequency error formula is $(f_c - f) / f_c \times 10^6$ ppm and the limit is less than ± 20 ppm (IEEE 802.11n specification).
6. The test extreme voltage is to change the primary supply voltage from 85 to 115 percent of the nominal value
7. Extreme temperature is $0^\circ\text{C} \sim 55^\circ\text{C}$.

4.8.4. Test Setup Layout

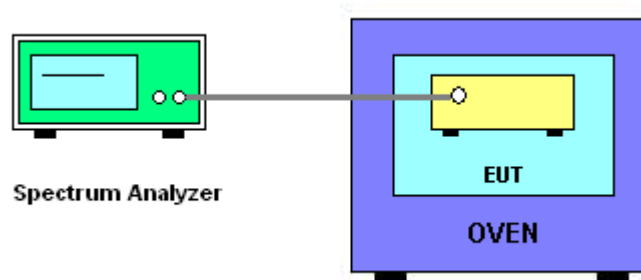

4.8.5. Test Deviation

There is no deviation with the original standard.

4.8.6. EUT Operation during Test

The EUT was programmed to be in continuously un-modulation transmitting mode.

4.8.7. Test Result of Frequency Stability

Temperature	23°C	Humidity	63%
Test Engineer	David Tseng	Test Date	Aug. 02, 2013

Voltage vs. Frequency Stability

Voltage (V)	Measurement Frequency (MHz)	
	5300	5500
126.50	5299.9712	5499.9682
110.00	5299.9712	5499.9674
93.50	5299.9744	5499.9680
Max. Deviation (MHz)	0.028800	0.032600
Max. Deviation (ppm)	5.43	5.93

Temperature vs. Frequency Stability

Temperature (°C)	Measurement Frequency (MHz)	
	5300	5500
0	5299.9722	5499.9720
10	5299.9712	5499.9720
20	5299.9712	5499.9724
30	5299.9716	5499.9720
40	5299.9722	5499.9720
50	5299.9712	5499.9722
55	5299.9987	5499.9887
Max. Deviation (MHz)	0.029000	0.032800
Max. Deviation (ppm)	5.47	5.96

4.9. Antenna Requirements

4.9.1. Limit

Except for special regulations, the Low-power Radio-frequency Devices must not be equipped with any jacket for installing an antenna with extension cable. An intentional radiator shall be designed to ensure that no antenna other than that furnished by the responsible party shall be used with the device. The use of a permanently attached antenna or of an antenna that uses a unique coupling to the intentional radiator shall be considered sufficient to comply with the provisions of this Section. The manufacturer may design the unit so that the user can replace a broken antenna, but the use of a standard antenna jack or electrical connector is prohibited. Further, this requirement does not apply to intentional radiators that must be professionally installed.

4.9.2. Antenna Connector Construction

Please refer to section 3.3 in this test report; antenna connector complied with the requirements.

5. LIST OF MEASURING EQUIPMENTS

Instrument	Manufacturer	Model No.	Serial No.	Characteristics	Calibration Date	Remark
EMI Test Receiver	R&S	ESCS 30	100377	9kHz ~ 2.75GHz	Oct. 23, 2012	Conduction (CO01-CB)
LISN	F.C.C.	FCC-LISN-50-16-2	04083	150kHz ~ 100MHz	Nov. 26, 2011	Conduction (CO01-CB)
V- LISN	Schwarzbeck	NSLK 8127	8127478	9kHz ~ 30MHz	Jun. 22, 2012	Conduction (CO01-CB)
Impulsbegrenzer Pulse Limiter	Rohde&Schwarz	ESH3-Z2	100430	9kHz~30MHz	Feb. 21, 2012	Conduction (CO01-CB)
COND Cable	Woken	Cable	01	0.15MHz~30MHz	Dec. 04, 2012	Conduction (CO01-CB)
Software	Audix	E3	5.410e	-	-	Conduction (CO01-CB)
BILOG ANTENNA	Schaffner	CBL6112D	22021	20MHz ~ 2GHz	Apr. 16, 2012	Radiation (03CH01-CB)
Loop Antenna	Teseq	HLA 6120	24155	9kHz - 30 MHz	Nov. 05, 2012*	Radiation (03CH01-CB)
Horn Antenna	EMCO	3115	00075790	750MHz~18GHz	Nov. 27, 2012	Radiation (03CH01-CB)
Horn Antenna	SCHWARZBEAK	BBHA 9170	BBHA9170252	15GHz ~ 40GHz	Nov. 23, 2012	Radiation (03CH01-CB)
Pre-Amplifier	Agilent	8447D	2944A10991	0.1MHz ~ 1.3GHz	Nov. 27, 2011	Radiation (03CH01-CB)
Pre-Amplifier	Agilent	8449B	3008A02310	1GHz ~ 26.5GHz	Nov. 23, 2012	Radiation (03CH01-CB)
Pre-Amplifier	WM	TF-130N-R1	923365	26.5GHz ~ 40GHz	Jul. 31, 2012	Radiation (03CH01-CB)
Spectrum analyzer	R&S	FSP40	100056	9kHz~40GHz	Nov. 16, 2012	Radiation (03CH01-CB)
EMI Test Receiver	R&S	ESCS 30	100355	9kHz ~ 2.75GHz	Apr. 12, 2012	Radiation (03CH01-CB)
Turn Table	INN CO	CO 2000	N/A	0 ~ 360 degree	N.C.R	Radiation (03CH01-CB)
Antenna Mast	INN CO	CO2000	N/A	1 m - 4 m	N.C.R	Radiation (03CH01-CB)
RF Cable-low	Woken	Low Cable-1	N/A	30 MHz - 1 GHz	Nov. 18, 2012	Radiation (03CH01-CB)
RF Cable-high	Woken	High Cable-1	N/A	1 GHz – 26.5 GHz	Nov. 18, 2012	Radiation (03CH01-CB)
RF Cable-high	Woken	High Cable-2	N/A	1 GHz – 26.5 GHz	Nov. 18, 2012	Radiation (03CH01-CB)
RF Cable-high	Woken	High Cable-3	N/A	1 GHz - 40 GHz	Nov. 18, 2012	Radiation (03CH01-CB)
RF Cable-high	Woken	High Cable-4	N/A	1 GHz - 40 GHz	Nov. 18, 2012	Radiation (03CH01-CB)
Signal analyzer	R&S	FSV40	100979	9kHz~40GHz	Oct. 08, 2012	Conducted (TH01-CB)
Temp. and Humidity Chamber	Ten Billion	TTH-D3SP	TBN-931011	-30~100 degree	Jun. 04, 2013	Conducted (TH01-CB)
RF Power Divider	Woken	2 Way	0120A02056002D	2GHz ~ 18GHz	Nov. 18, 2012	Conducted (TH01-CB)

Instrument	Manufacturer	Model No.	Serial No.	Characteristics	Calibration Date	Remark
RF Power Divider	Woken	3 Way	MDC2366	2GHz ~ 18GHz	Nov. 18, 2012	Conducted (TH01-CB)
RF Cable-high	Woken	High Cable-7	-	1 GHz – 26.5 GHz	Nov. 19, 2012	Conducted (TH01-CB)
RF Cable-high	Woken	High Cable-8	-	1 GHz – 26.5 GHz	Nov. 19, 2012	Conducted (TH01-CB)
RF Cable-high	Woken	High Cable-9	-	1 GHz – 26.5 GHz	Nov. 19, 2012	Conducted (TH01-CB)
RF Cable-high	Woken	High Cable-10	-	1 GHz – 26.5 GHz	Nov. 19, 2012	Conducted (TH01-CB)
RF Cable-high	Woken	High Cable-11	-	1 GHz – 26.5 GHz	Nov. 19, 2012	Conducted (TH01-CB)
Power Sensor	Anritsu	MA2411B	0917223	300MHz~40GHz	Nov. 28, 2012	Conducted (TH01-CB)
Power Meter	Anritsu	ML2495A	1035008	300MHz~40GHz	Nov. 27, 2012	Conducted (TH01-CB)

Note: Calibration Interval of instruments listed above is one year.

“*” Calibration Interval of instruments listed above is two years.

NCR means Non-Calibration required.

6. TEST LOCATION

SHIJR	ADD : 6Fl., No. 106, Sec. 1, Shintai 5th Rd., Shijr City, Taipei, Taiwan 221, R.O.C. TEL : 886-2-2696-2468 FAX : 886-2-2696-2255
HWA YA	ADD : No. 52, Hwa Ya 1st Rd., Kwei-Shan Hsiang, Tao Yuan Hsien, Taiwan, R.O.C. TEL : 886-3-327-3456 FAX : 886-3-318-0055
LINKOU	ADD : No. 30-2, Dingfu Tsuen, Linkou Shiang, Taipei, Taiwan 244, R.O.C TEL : 886-2-2601-1640 FAX : 886-2-2601-1695
DUNGHU	ADD : No. 3, Lane 238, Kangle St., Neihu Chiu, Taipei, Taiwan 114, R.O.C. TEL : 886-2-2631-4739 FAX : 886-2-2631-9740
JUNGHE	ADD : 7Fl., No. 758, Jungjeng Rd., Junghe City, Taipei, Taiwan 235, R.O.C. TEL : 886-2-8227-2020 FAX : 886-2-8227-2626
NEIHU	ADD : 4Fl., No. 339, Hsin Hu 2 nd Rd., Taipei 114, Taiwan, R.O.C. TEL : 886-2-2794-8886 FAX : 886-2-2794-9777
JHUBEI	ADD : No.8, Lane 724, Bo-ai St., Jhubei City, HsinChu County 302, Taiwan, R.O.C. TEL : 886-3-656-9065 FAX : 886-3-656-9085

7. MEASUREMENT UNCERTAINTY

Uncertainty of Conducted Emission Measurement (150kHz ~ 30MHz)

Contribution	Uncertainty of x_i			$u(x_i)$
	Value	Unit	Probability Distribution k	
Receiver reading	0.026	dB	normal(k=2)	0.013
Cable loss	0.002	dB	normal(k=2)	0.001
AMN/LISN specification	1.200	dB	normal(k=2)	0.600
Mismatch Receiver VSWR Γ_1 = AMN/LISN VSWR Γ_2 =	-0.080	dB	U-shaped	0.060
Combined standard uncertainty $U_c(y)$				1.2
Measuring uncertainty for a level of confidence of 95% $U=2U_c(y)$				2.4

Uncertainty of Radiated Emission Measurement (30MHz ~ 1,000MHz)

Contribution	Uncertainty of x_i			$u(x_i)$
	Value	Unit	Probability Distribution k	
Receiver reading	± 0.173	dB	K=1	0.086
Cable loss	± 0.174	dB	K=2	0.087
Antenna gain	± 0.169	dB	K=2	0.084
Site imperfection	± 0.433	dB	Triangular	0.214
Pre-amplifier gain	± 0.366	dB	K=2	0.183
Transmitter antenna	± 1.200	dB	Rectangular	0.600
Signal generator	± 0.461	dB	Rectangular	0.231
Mismatch	± 0.080	dB	U-shape	0.040
Spectrum analyzer	± 0.500	dB	Rectangular	0.250
Combined standard uncertainty $U_c(y)$				1.778
Measuring uncertainty for a level of confidence of 95% $U=2U_c(y)$				3.555

Uncertainty of Radiated Emission Measurement (1GHz ~ 18GHz)

Contribution	Uncertainty of x_i			$u(x_i)$
	Value	Unit	Probability Distribution k	
Receiver reading	±0.191	dB	K=1	0.095
Cable loss	±0.169	dB	K=2	0.084
Antenna gain	±0.191	dB	K=2	0.096
Site imperfection	±0.582	dB	Triangular	0.291
Pre-amplifier gain	±0.304	dB	K=2	0.152
Transmitter antenna	±1.200	dB	Rectangular	0.600
Signal generator	±0.461	dB	Rectangular	0.231
Mismatch	±0.080	dB	U-shape	0.040
Spectrum analyzer	±0.500	dB	Rectangular	0.250
Combined standard uncertainty $U_c(y)$				1.839
Measuring uncertainty for a level of confidence of 95% $U=2U_c(y)$				3.678

Uncertainty of Radiated Emission Measurement (18GHz ~ 40GHz)

Contribution	Uncertainty of x_i			$u(x_i)$
	Value	Unit	Probability Distribution k	
Receiver reading	±0.186	dB	K=1	0.093
Cable loss	±0.167	dB	K=2	0.083
Antenna gain	±0.190	dB	K=2	0.095
Site imperfection	±0.488	dB	Triangular	0.244
Pre-amplifier gain	±0.269	dB	K=2	0.134
Transmitter antenna	±1.200	dB	Rectangular	0.600
Signal generator	±0.461	dB	Rectangular	0.231
Mismatch	±0.080	dB	U-shape	0.040
Spectrum analyzer	±0.500	dB	Rectangular	0.250
Combined standard uncertainty $U_c(y)$				1.771
Measuring uncertainty for a level of confidence of 95% $U=2U_c(y)$				3.541

Uncertainty of Conducted Emission Measurement

Contribution	Uncertainty of x_i			$u(x_i)$
	Value	Unit	Probability Distribution k	
Cable loss	±0.038	dB	K=2	0.019
Attenuator	±0.047	dB	K=2	0.024
Power Meter specification	±0.300	dB	Triangular	0.150
Power Sensor specification	±0.300	dB	Rectangular	0.150
Signal generator	±0.461	dB	Rectangular	0.231
Mismatch	±0.080	dB	U-shape	0.040
Spectrum analyzer	±0.500	dB	Rectangular	0.250
Combined standard uncertainty $U_c(y)$				0.863
Measuring uncertainty for a level of confidence of 95% $U=2U_c(y)$				1.726