



# FCC TEST REPORT (15.407)

**REPORT NO.:** RF961122H02  
**MODEL NO.:** WUSB600N  
**RECEIVED:** Nov. 22, 2007  
**TESTED:** Nov. 24 to Dec. 05, 2007  
**ISSUED:** Dec. 10, 2007

**APPLICANT:** Cisco-Linksys LLC  
**ADDRESS:** 121 Theory Drive Irvine, CA 92617(USA)

**ISSUED BY:** Advance Data Technology Corporation

**TEST LOCATION:** No. 81-1, Lu Liao Keng, 9 Ling, Wu Lung  
Tsuen, Chiung Lin Hsiang, Hsin Chu Hsien,  
Taiwan, R.O.C.

This test report consists of 197 pages in total. It may be duplicated completely for legal use with the approval of the applicant. It should not be reproduced except in full, without the written approval of our laboratory. The client should not use it to claim product endorsement by TAF, A2LA or any government agencies. The test results in the report only apply to the tested sample.



No. 2177-01



## Table of Contents

1.	CERTIFICATION .....	4
2.	SUMMARY OF TEST RESULTS .....	5
2.1	MEASUREMENT UNCERTAINTY .....	6
3.	GENERAL INFORMATION .....	7
3.1	GENERAL DESCRIPTION OF EUT .....	7
3.2	DESCRIPTION OF TEST MODES .....	10
3.2.1	TEST MODE APPLICABILITY AND TESTED CHANNEL DETAIL: .....	11
3.3	GENERAL DESCRIPTION OF APPLIED STANDARDS .....	14
3.4	DESCRIPTION OF SUPPORT UNITS.....	15
3.5	CONFIGURATION OF SYSTEM UNDER TEST .....	15
4.	TEST TYPES AND RESULTS .....	16
4.1	CONDUCTED EMISSION MEASUREMENT .....	16
4.1.1	LIMITS OF CONDUCTED EMISSION MEASUREMENT .....	16
4.1.2	TEST INSTRUMENTS.....	16
4.1.3	TEST PROCEDURES .....	17
4.1.4	DEVIATION FROM TEST STANDARD .....	17
4.1.5	TEST SETUP .....	18
4.1.6	EUT OPERATING CONDITIONS .....	18
4.1.7	TEST RESULTS .....	19
4.2	RADIATED EMISSION MEASUREMENT .....	21
4.2.1	LIMITS OF RADIATED EMISSION MEASUREMENT .....	21
4.2.2	LIMITS OF UNWANTED EMISSION OUT OF THE RESTRICTED BANDS.....	22
4.2.3	TEST INSTRUMENTS.....	23
4.2.4	TEST PROCEDURES .....	24
4.2.5	DEVIATION FROM TEST STANDARD .....	24
4.2.6	TEST SETUP .....	25
4.2.7	EUT OPERATING CONDITION.....	25
	<a href="#">Below 1GHz Test Data</a> .....	26
4.2.8	TEST RESULTS .....	26
	<a href="#">Above 1GHz Test Data</a> .....	27
4.2.9	TEST RESULTS .....	27
4.3	PEAK TRANSMIT POWER MEASUREMENT .....	66
4.3.1	LIMITS OF PEAK TRANSMIT POWER MEASUREMENT .....	66
4.3.2	TEST INSTRUMENTS.....	66
4.3.3	TEST PROCEDURE.....	67
4.3.4	DEVIATION FROM TEST STANDARD .....	67



4.3.5	TEST SETUP .....	67
4.3.6	EUT OPERATING CONDITIONS .....	67
4.3.7	TEST RESULTS .....	68
4.4	PEAK POWER EXCURSION MEASUREMENT .....	111
4.4.1	LIMITS OF PEAK POWER EXCURSION MEASUREMENT .....	111
4.4.2	TEST INSTRUMENTS.....	111
4.4.3	TEST PROCEDURE.....	112
4.4.4	DEVIATION FROM TEST STANDARD .....	112
4.4.5	TEST SETUP .....	112
4.4.6	EUT OPERATING CONDITIONS .....	112
4.4.7	TEST RESULTS .....	113
4.5	PEAK POWER SPECTRAL DENSITY MEASUREMENT .....	135
4.5.1	LIMITS OF PEAK POWER SPECTRAL DENSITY MEASUREMENT .....	135
4.5.2	TEST INSTRUMENTS.....	135
4.5.3	TEST PROCEDURES .....	136
4.5.4	DEVIATION FROM TEST STANDARD .....	136
4.5.5	TEST SETUP .....	136
4.5.6	EUT OPERATING CONDITIONS .....	136
4.5.7	TEST RESULTS .....	137
4.6	FREQUENCY STABILITY.....	159
4.6.1	LIMITS OF FREQUENCY STABILITY MEASUREMENT .....	159
4.6.2	TEST INSTRUMENTS.....	159
4.6.3	TEST PROCEDURE.....	159
4.6.4	DEVIATION FROM TEST STANDARD .....	160
4.6.5	TEST SETUP .....	160
4.6.6	EUT OPERATING CONDITION.....	160
4.6.7	TEST RESULTS .....	161
4.7	BAND EDGES MEASUREMENT.....	162
4.7.1	TEST INSTRUMENTS.....	162
4.7.2	TEST PROCEDURE.....	162
4.7.3	EUT OPERATING CONDITION.....	162
4.7.4	TEST RESULTS .....	163
4.8	ANTENNA REQUIREMENT .....	195
4.8.1	STANDARD APPLICABLE.....	195
4.8.2	ANTENNA CONNECTED CONSTRUCTION.....	195
5.	INFORMATION ON THE TESTING LABORATORIES .....	196
6.	APPENDIX-A- MODIFICATIONS RECORDERS FOR ENGINEERING CHANGES TO THE EUT BY THE LAB .....	197



## 1. CERTIFICATION

**PRODUCT:** Dual-Band Wireless-N USB Network Adapter  
**BRAND NAME:** Linksys  
**MODEL NO.:** WUSB600N  
**TEST SAMPLE:** R&D SAMPLE  
**TESTED:** Nov. 24 to Dec. 05, 2007  
**APPLICANT:** Cisco-Linksys LLC  
**STANDARDS:** FCC Part 15, Subpart E (Section 15.407)  
ANSI C63.4-2003

The above equipment (Model: WUSB600N) has been tested by **Advance Data Technology Corporation**, and found compliance with the requirement of the above standards. The test record, data evaluation & Equipment Under Test (EUT) configurations represented herein are true and accurate accounts of the measurements of the sample's EMC characteristics under the conditions specified in this report.

**PREPARED BY** : Midoli Peng , **DATE:** Dec. 10, 2007  
( Midoli Peng, Specialist )

**TECHNICAL ACCEPTANCE** : Hank Chung , **DATE:** Dec. 10, 2007  
Responsible for RF ( Hank Chung, Deputy Manager )

**APPROVED BY** : May Chen , **DATE:** Dec. 10, 2007  
( May Chen, Deputy Manager )

## 2. SUMMARY OF TEST RESULTS

The EUT has been tested according to the following specifications:

<b>APPLIED STANDARD: FCC Part 15, Subpart E (Section 15.407)</b>			
<b>Standard Section</b>	<b>Test Type</b>	<b>Result</b>	<b>Remark</b>
15.407(b)(5)	AC Power Conducted Emission	PASS	Meet the requirement of limit. Minimum passing margin is -10.45dB at 0.177MHz
15.407(b/1/2/3) (b)(5)	Electric Field Strength Spurious Emissions, 30MHz ~ 40000MHz	PASS	Meet the requirement of limit. Minimum passing margin is -0.4dB at 9072.00MHz
15.407(a/1/2/3)	Peak Transmit Power	PASS	Meet the requirement of limit.
15.407(a)(6)	Peak Power Excursion	PASS	Meet the requirement of limit.
15.407(a/1/2/3)	Peak Power Spectral Density	PASS	Meet the requirement of limit.
15.407(g)	Frequency Stability	PASS	Meet the requirement of limit.

**NOTE:**

1. The EUT was operating in 2.412 ~ 2.462GHz, 5.15~5.35GHz, 5.47~5.725GHz and 5.725~5.850GHz frequencies band. This report was recorded the RF parameters including 5.15~5.35GHz and 5.47~5.725GHz. For the 2.412 ~ 2.462GHz and 5.725 ~ 5.850GHz RF parameters was recorded in another test report.

## 2.1 MEASUREMENT UNCERTAINTY

Where relevant, the following measurement uncertainty levels have been estimated for tests performed on the EUT as specified in CISPR 16-4:

This uncertainty represents an expanded uncertainty expressed at approximately the 95% confidence level using a coverage factor of k=2.

<b>Measurement</b>	<b>Value</b>
Conducted emissions	2.44 dB
Radiated emissions (30MHz-1GHz)	3.94 dB
Radiated emissions (1GHz -18GHz)	2.33 dB
Radiated emissions (18GHz -40GHz)	2.55 dB

### 3. GENERAL INFORMATION

#### 3.1 GENERAL DESCRIPTION OF EUT

<b>PRODUCT</b>	Dual-Band Wireless-N USB Network Adapter
<b>MODEL NO.</b>	WUSB600N
<b>FCC ID</b>	Q87-WUSB600N
<b>POWER SUPPLY</b>	DC 5V from host equipment
<b>MODULATION TYPE</b>	CCK, DQPSK, DBPSK for DSSS 64QAM, 16QAM, QPSK, BPSK for OFDM
<b>MODULATION TECHNOLOGY</b>	DSSS, OFDM
<b>TRANSFER RATE</b>	802.11b: 11 / 5.5 / 2 / 1Mbps 802.11g: 54 / 48 / 36 / 24 / 18 / 12 / 9 / 6Mbps 802.11a: 54 / 48 / 36 / 24 / 18 / 12 / 9 / 6Mbps Draft 802.11n (20MHz): 130 / 117 / 104 / 78 / 65 / 58.5 / 52 / 39 / 26 / 19.5 / 13 / 6.5Mbps Draft 802.11n (40MHz): 270 / 243 / 216 / 162 / 135 / 121.5 / 108 / 81 / 54 / 40.5 / 27 / 13.5Mbps
<b>FREQUENCY RANGE</b>	For 15.407 802.11a: 5.18 ~ 5.32GHz and 5.50 ~ 5.70GHz
	For 15.247 802.11b & 802.11g: 2412 ~ 2462MHz 802.11a: 5.745 ~ 5.825GHz
<b>NUMBER OF CHANNEL</b>	<b>For 15.407</b> 19 for 802.11a, draft 802.11n (20MHz) 9 for draft 802.11n (40MHz)
	<b>For 15.247(2.4GHz)</b> 11 for 802.11b, 802.11g, draft 802.11n (20MHz) 7 for draft 802.11n (40MHz) <b>For 15.247(5GHz)</b> 5 for 802.11a, draft 802.11n (20MHz) 3 for draft 802.11n (40MHz)

<b>MAXIMUM OUTPUT POWER</b>	<b>For 15.407</b> 802.11a: 32.961mW draft 802.11n (20MHz): 32.489mW draft 802.11n (40MHz): 36.377mW <b>For 15.247(2.4GHz)</b> 802.11b: 34.674mW 802.11g: 97.724mW draft 802.11n (20MHz): 133.677mW draft 802.11n (40MHz): 132.138mW <b>For 15.247(5GHz)</b> 802.11a: 47.863mW draft 802.11n (20MHz): 81.563mW draft 802.11n (40MHz): 85.882mW
<b>ANTENNA TYPE</b>	Please see note 1
<b>DATA CABLE</b>	NA
<b>INTERFACE</b>	USB
<b>ASSOCIATED DEVICES</b>	Cradle (with 1.8m cable, shielded)

**NOTE:**

1. There are two antennas provided to this EUT, please refer to the following table:

No.	Antenna Type	For 2.4GHz Gain (dBi)	For 5GHz Gain (dBi)	Antenna Connector
1	PCB Print	2	4	NA
2	PCB Print	2	4	NA

2. The EUT incorporates a MIMO function with 802.11a, 802.11b, 802.11g, draft 802.11n. Physically, the EUT provides two completed transmit and two completed receivers.
3. The EUT is 2 \* 2 spatial MIMO (2Tx & 2Rx) without beam forming function. The antenna configurations are two transmitter antennas and two receiver antennas, as there are 2 PCB Print antennas. Spatial multiplexing modes for simultaneous transmission using 2 antennas, and for simultaneous receiver using 2 antennas.
4. When the EUT operating in draft 802.11n, the software operation, which is defined by manufacturer, MCS (Modulation and Coding Schemes) from 0 to 15.





5. The EUT complies with draft 802.11n standards and backwards compatible with 802.11a, 802.11b, 802.11g products.
6. The above EUT information was declared by manufacturer and for more detailed features description, please refer to the manufacturer's specifications or user's manual.

### 3.2 DESCRIPTION OF TEST MODES

#### Operated in 5150MHz ~ 5350MHz bands:

Eight channels are provided for 802.11a and draft 802.11n (20MHz):

CHANNEL	FREQUENCY
1	5180 MHz
2	5200 MHz
3	5220 MHz
4	5240 MHz
5	5260 MHz
6	5280 MHz
7	5300 MHz
8	5320 MHz

Four channels are provided for draft 802.11n (40MHz):

CHANNEL	FREQUENCY
1	5190 MHz
2	5230 MHz
3	5270 MHz
4	5310 MHz

#### Operated in 5470MHz ~ 5725MHz bands:

Eleven channels are provided for 802.11a and draft 802.11n (20MHz):

CHANNEL	FREQUENCY
9	5500 MHz
10	5520 MHz
11	5540 MHz
12	5560 MHz
13	5580 MHz
14	5600 MHz
15	5620 MHz
16	5640 MHz
17	5660 MHz
18	5680 MHz
19	5700 MHz

Five channels are provided for draft 802.11n (40MHz):

CHANNEL	FREQUENCY
5	5510 MHz
6	5550 MHz
7	5590 MHz
8	5630 MHz
9	5670 MHz

### 3.2.1 TEST MODE APPLICABILITY AND TESTED CHANNEL DETAIL:

EUT CONFIGURE MODE	APPLICABLE TO				DESCRIPTION
	PLC	RE < 1G	RE ≥ 1G	APCM	
-	√	√	√	√	-

Where **PLC**: Power Line Conducted Emission

**RE < 1G**: Radiated Emission below 1GHz

**RE ≥ 1G**: Radiated Emission above 1GHz

**APCM**: Antenna Port Conducted Measurement

### ANTENNA COMBINATION MODE:

COMBINATION MODE	OPERATION MODE	CHAIN(0) (TX/RX)	CHAIN(1) (TX/RX)
A	802.11a	√	
B	DRAFT 802.11n(20MHz)	√	√
C	DRAFT 802.11n(40MHz)	√	√

Note:

1. The above information was declared by manufacturer and for more detailed features description, please refer to the manufacturer's specifications or user's manual.
2. Antenna 1 and Antenna 2 are PCB Print antennas.



**Power Line Conducted Emission Test:**

- Pre-Scan has been conducted to determine the worst-case mode from all possible combinations between available modulations, data rates and antenna ports (if EUT with antenna diversity architecture).
- Following channel(s) was (were) selected for the final test as listed below.

MODE	AVAILABLE CHANNEL	TESTED CHANNEL	MODULATION TECHNOLOGY	MODULATION TYPE	DATA RATE (Mbps)	TX COMBINATION
For 5 GHz Draft 802.11n (20MHz)	1 to 19	1	OFDM	BPSK	13	B

**Radiated Emission Test (Below 1 GHz):**

- Pre-Scan has been conducted to determine the worst-case mode from all possible combinations between available modulations, data rates and antenna ports (if EUT with antenna diversity architecture).
- Following channel(s) was (were) selected for the final test as listed below.

MODE	AVAILABLE CHANNEL	TESTED CHANNEL	MODULATION TECHNOLOGY	MODULATION TYPE	DATA RATE (Mbps)	TX COMBINATION
For 5 GHz Draft 802.11n (20MHz)	1 to 19	1	OFDM	BPSK	13	B

- The EUT was pre-tested in chamber as the following test modes:

TEST MODE	DESCRIPTION
Mode A	With Cradle
Mode B	Without Cradle

The worst case was found in Mode A. Their test data were recorded in this report individually.

**Radiated Emission Test (Above 1 GHz):**

- Pre-Scan has been conducted to determine the worst-case mode from all possible combinations between available modulations, data rates and antenna ports (if EUT with antenna diversity architecture).
- Following channel(s) was (were) selected for the final test as listed below.

MODE	AVAILABLE CHANNEL	TESTED CHANNEL	MODULATION TECHNOLOGY	MODULATION TYPE	DATA RATE (Mbps)	TX COMBINATION
802.11a	1 to 19	1, 4, 5, 8, 9, 14, 19	OFDM	BPSK	6	A
For 5 GHz Draft 802.11n (20MHz)	1 to 19	1, 4, 5, 8, 9, 14, 19	OFDM	BPSK	13	B
For 5 GHz Draft 802.11n (40MHz)	1 to 9	1, 2, 3, 4, 5, 7, 9	OFDM	BPSK	27	C

- The EUT was pre-tested in chamber as the following test modes:

TEST MODE	DESCRIPTION
Mode A	With Cradle
Mode B	Without Cradle

The worst case was found in Mode A. Their test data were recorded in this report individually.

### **Bandedge Measurement:**

- Pre-Scan has been conducted to determine the worst-case mode from all possible combinations between available modulations, data rates and antenna ports (if EUT with antenna diversity architecture).
- Following channel(s) was (were) selected for the final test as listed below.

MODE	AVAILABLE CHANNEL	TESTED CHANNEL	MODULATION TECHNOLOGY	MODULATION TYPE	DATA RATE (Mbps)	TX COMBINATION
802.11a	1 to 19	1, 8, 9	OFDM	BPSK	6	A
For 5 GHz Draft 802.11n (20MHz)	1 to 19	1, 8, 9	OFDM	BPSK	13	B
For 5 GHz Draft 802.11n (40MHz)	1 to 9	1, 4, 5	OFDM	BPSK	27	C

- The EUT was pre-tested in chamber as the following test modes:

TEST MODE	DESCRIPTION
Mode A	With Cradle
Mode B	Without Cradle

The worst case was found in Mode A. Their test data were recorded in this report individually.

### **Antenna Port Conducted Measurement:**

- Pre-Scan has been conducted to determine the worst-case mode from all possible combinations between available modulations, data rates and antenna ports (if EUT with antenna diversity architecture).
- Following channel(s) was (were) selected for the final test as listed below.

MODE	AVAILABLE CHANNEL	TESTED CHANNEL	MODULATION TECHNOLOGY	MODULATION TYPE	DATA RATE (Mbps)	TX COMBINATION
802.11a	1 to 19	1, 4, 5, 8, 9, 14, 19	OFDM	BPSK	6	A
For 5 GHz Draft 802.11n (20MHz)	1 to 19	1, 4, 5, 8, 9, 14, 19	OFDM	BPSK	13	B
For 5 GHz Draft 802.11n (40MHz)	1 to 9	1, 2, 3, 4, 5, 7, 9	OFDM	BPSK	27	C



### **3.3 GENERAL DESCRIPTION OF APPLIED STANDARDS**

The EUT is a Dual-Band Wireless-N USB Network Adapter. According to the specifications of the manufacturer, it must comply with the requirements of the following standards:

**FCC Part 15, Subpart E (15.407)**

**ANSI C63.4-2003**

All test items have been performed and recorded as per the above standards.

### 3.4 DESCRIPTION OF SUPPORT UNITS

The EUT has been tested as an independent unit together with other necessary accessories or support units. The following support units or accessories were used to form a representative test configuration during the tests.

NO.	PRODUCT	BRAND	MODEL NO.	SERIAL NO.	FCC ID
1	NOTEBOOK COMPUTER	DELL	PP18L	6976685584	FCC DoC

NO.	SIGNAL CABLE DESCRIPTION OF THE ABOVE SUPPORT UNITS
1	NA

**NOTE:** All power cords of the above support units are non shielded (1.8m).

### 3.5 CONFIGURATION OF SYSTEM UNDER TEST

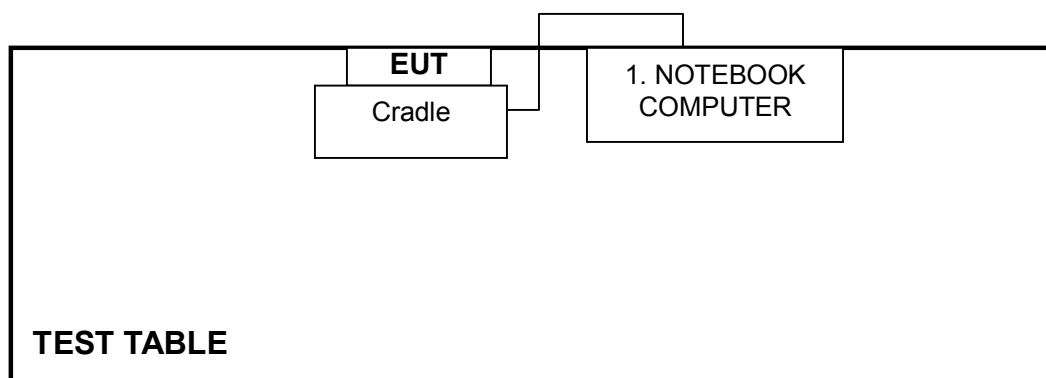

## 4. TEST TYPES AND RESULTS

### 4.1 CONDUCTED EMISSION MEASUREMENT

#### 4.1.1 LIMITS OF CONDUCTED EMISSION MEASUREMENT

FREQUENCY OF EMISSION (MHz)	CONDUCTED LIMIT (dB $\mu$ V)	
	Quasi-peak	Average
0.15-0.5	66 to 56	56 to 46
0.5-5	56	46
5-30	60	50

- NOTE:**
1. The lower limit shall apply at the transition frequencies.
  2. The limit decreases in line with the logarithm of the frequency in the range of 0.15 to 0.50 MHz.
  3. All emanations from a class A/B digital device or system, including any network of conductors and apparatus connected thereto, shall not exceed the level of field strengths specified above.

#### 4.1.2 TEST INSTRUMENTS

DESCRIPTION & MANUFACTURER	MODEL NO.	SERIAL NO.	CALIBRATED UNTIL
Test Receiver	ESCS 30	847124/029	Mar. 28, 2008
Line-Impedance Stabilization Network(for EUT)	ENV-216	100071	Nov. 26, 2008
Line-Impedance Stabilization Network(for Peripheral)	ESH3-Z5	848773/004	Nov. 08, 2008
RF Cable (JETBAO)	RG233/U	Cable_CB_01	Dec. 09, 2007
Terminator	50	2	Oct. 30, 2008
Software	ADT_Cond_V7.3.2	NA	NA

- NOTE:**
1. The calibration interval of the above test instruments is 12 months and the calibrations are traceable to NML/ROC and NIST/USA.
  2. The test was performed in ADT Shielded Room No. B.
  3. The VCCI Con B Registration No. is C-2193.



#### 4.1.3 TEST PROCEDURES

- a. The EUT was placed 0.4 meters from the conducting wall of the shielded room with EUT being connected to the power mains through a line impedance stabilization network (LISN). Other support units were connected to the power mains through another LISN. The two LISNs
- b. provide 50 ohm/ 50uH of coupling impedance for the measuring instrument.
- c. Both lines of the power mains connected to the EUT were checked for maximum conducted interference.
- d. The frequency range from 150kHz to 30MHz was searched. Emission level under (Limit – 20dB) was not recorded.

#### 4.1.4 DEVIATION FROM TEST STANDARD

No deviation

#### 4.1.5 TEST SETUP

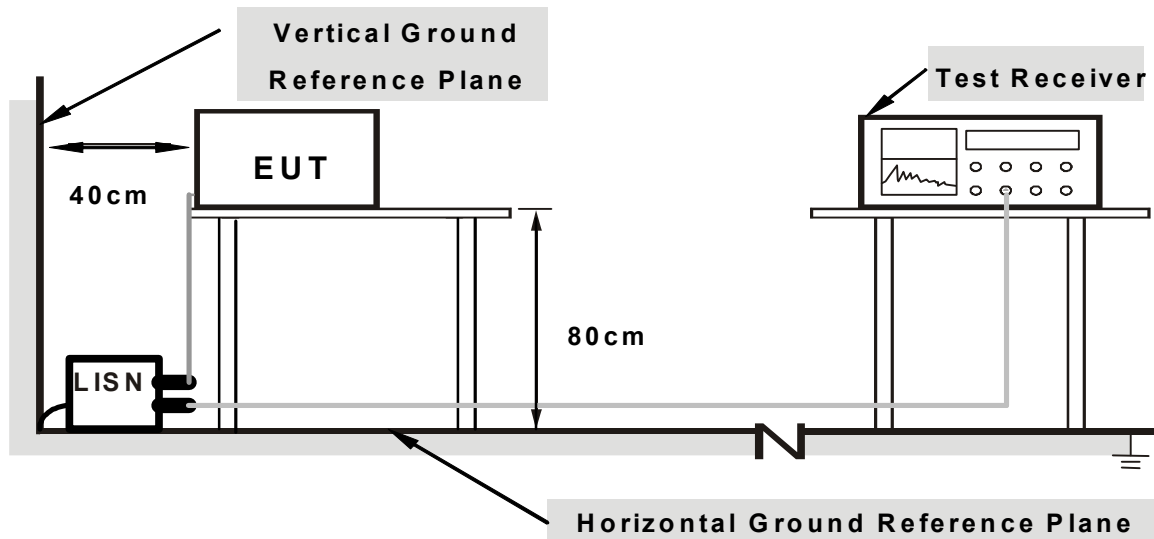

**Note: 1. Support units were connected to second LISN.**

**2. Both of LISNs (AMN) are 80 cm from EUT and at least 80 from other units and other metal planes**

For the actual test configuration, please refer to the related item – Photographs of the Test Configuration.

#### 4.1.6 EUT OPERATING CONDITIONS

- a. Connect the EUT with the support unit 1 (Notebook computer) which placed on a testing table.
- b. The support unit 1 (Notebook computer) ran a test program “RT2870QA .exe” to enable EUT under transmission condition continuously.

#### 4.1.7 TEST RESULTS

#### DRAFT 802.11n (20MHz) OFDM MODULATION:

EUT TEST CONDITION		MEASUREMENT DETAIL	
CHANNEL	Channel 1	PHASE	Line (L)
MODULATION TYPE	BPSK	6dB BANDWIDTH	9 kHz
TRANSFER RATE	13Mbps	INPUT POWER (SYSTEM)	120Vac, 60 Hz
ENVIRONMENTAL CONDITIONS	20deg. C, 60%RH, 971hPa	TESTED BY	Moris Lin

No	Freq. [MHz]	Corr. Factor (dB)	Reading Value [dB (uV)]		Emission Level [dB (uV)]		Limit [dB (uV)]		Margin (dB)	
			Q.P.	AV.	Q.P.	AV.	Q.P.	AV.	Q.P.	AV.
			1	0.177	0.15	54.01	-	54.16	-	64.61
2	0.236	0.16	48.44	-	48.60	-	62.24	52.24	-13.64	-
3	0.295	0.16	43.58	-	43.74	-	60.40	50.40	-16.65	-
4	0.353	0.17	41.00	-	41.17	-	58.89	48.89	-17.72	-
5	0.470	0.18	38.04	-	38.22	-	56.51	46.51	-18.29	-
6	0.646	0.22	37.01	-	37.23	-	56.00	46.00	-18.77	-

- REMARKS:**
1. Q.P. and AV. are abbreviations of quasi-peak and average individually.
  2. "-": The Quasi-peak reading value also meets average limit and measurement with the average detector is unnecessary.
  3. The emission levels of other frequencies were very low against the limit.
  4. Margin value = Emission level - Limit value
  5. Correction factor = Insertion loss + Cable loss
  6. Emission Level = Correction Factor + Reading Value.

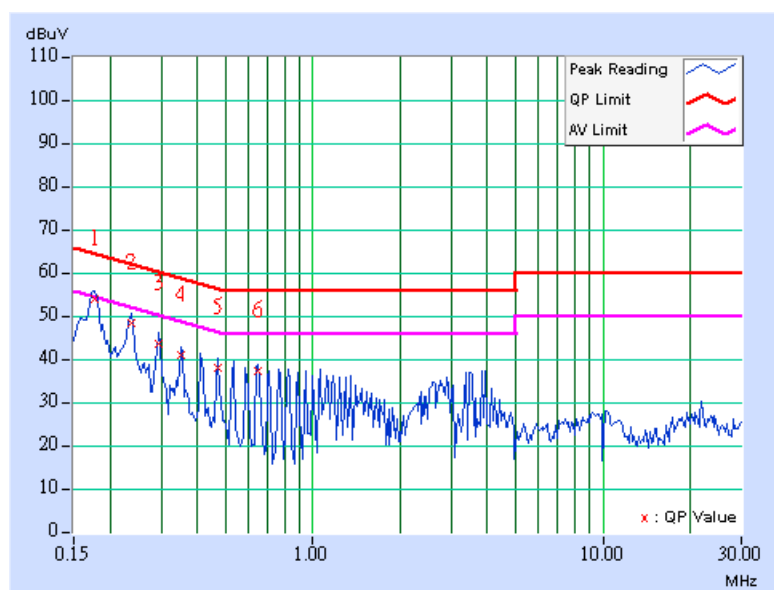

EUT TEST CONDITION		MEASUREMENT DETAIL	
CHANNEL	Channel 1	PHASE	Neutral (N)
MODULATION TYPE	BPSK	6dB BANDWIDTH	9 kHz
TRANSFER RATE	13Mbps	INPUT POWER (SYSTEM)	120Vac, 60 Hz
ENVIRONMENTAL CONDITIONS	20deg. C, 60%RH, 971hPa	TESTED BY	Moris Lin

No	Freq. [MHz]	Corr. Factor (dB)	Reading Value [dB (uV)]		Emission Level [dB (uV)]		Limit [dB (uV)]		Margin (dB)	
			Q.P.	AV.	Q.P.	AV.	Q.P.	AV.	Q.P.	AV.
1	0.173	0.08	52.60	-	52.68	-	64.79	54.79	-12.12	-
2	0.236	0.08	47.54	-	47.62	-	62.24	52.24	-14.62	-
3	0.291	0.08	43.12	-	43.20	-	60.51	50.51	-17.31	-
4	0.353	0.08	41.50	-	41.58	-	58.89	48.89	-17.31	-
5	0.412	0.08	40.31	-	40.39	-	57.61	47.61	-17.22	-
6	0.529	0.10	38.56	-	38.66	-	56.00	46.00	-17.34	-
7	0.705	0.14	38.92	-	39.06	-	56.00	46.00	-16.94	-

- REMARKS:**
1. Q.P. and AV. are abbreviations of quasi-peak and average individually.
  2. "-": The Quasi-peak reading value also meets average limit and measurement with the average detector is unnecessary.
  3. The emission levels of other frequencies were very low against the limit.
  4. Margin value = Emission level - Limit value
  5. Correction factor = Insertion loss + Cable loss
  6. Emission Level = Correction Factor + Reading Value.

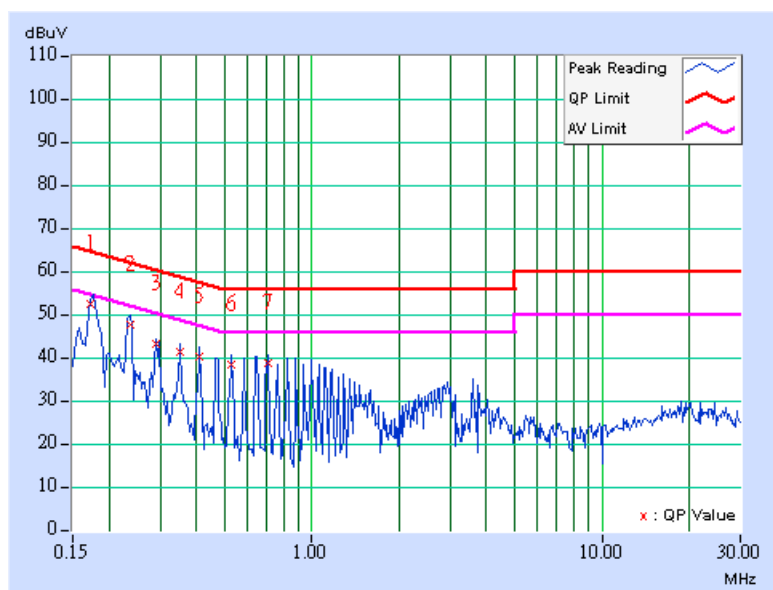



## 4.2 RADIATED EMISSION MEASUREMENT

### 4.2.1 LIMITS OF RADIATED EMISSION MEASUREMENT

Emissions radiated outside of the specified bands, shall be according to the general radiated limits in 15.209 as following:

Frequencies (MHz)	Field strength (microvolts/meter)	Measurement distance (meters)
0.009-0.490	2400/F(kHz)	300
0.490-1.705	24000/F(kHz)	30
1.705-30.0	30	30
30-88	100	3
88-216	150	3
216-960	200	3
Above 960	500	3

**NOTE:**

1. The lower limit shall apply at the transition frequencies.
2. Emission level (dBuV/m) = 20 log Emission level (uV/m).
3. As shown in 15.35(b), for frequencies above 1000MHz, the field strength limits are based on average detector, however, the peak field strength of any emission shall not exceed the maximum permitted average limits, specified above by more than 20dB under any condition of modulation.

#### 4.2.2 LIMITS OF UNWANTED EMISSION OUT OF THE RESTRICTED BANDS

Frequencies (MHz)	EIRP Limit (dBm)	Equivalent Field Strength at 3m (dBμV/m) *note 3
5150~5250	-27	68.3
5250~5350	-27	68.3
5470~5725	-27	68.3
5725~5825	-27 *note 1	68.3
	-17 *note 2	78.3

**NOTE:**

1. For frequencies 10MHz or greater above or below the band edge.
2. All emissions within the frequency range from the band edge to 10MHz above or below the band edge.
3. The following formula is used to convert the equipment isotropic radiated power (eirp) to field strength

$$E = \frac{1000000\sqrt{30P}}{3} \mu\text{V/m, where P is the eirp (Watts)}$$



#### 4.2.3 TEST INSTRUMENTS

DESCRIPTION & MANUFACTURER	MODEL NO.	SERIAL NO.	CALIBRATED UNTIL
ADVANTEST Spectrum Analyzer	R3271A	85060311	July 15, 2008
HP Pre_Amplifier	8449B	3008A01922	Oct. 04, 2008
ROHDE & SCHWARZ Test Receiver	ESCS30	100375	Mar. 26, 2008
CHASE Broadband Antenna	VULB 9168	138	July 26, 2008
Schwarzbeck Horn_Antenna	BBHA9120	D124	Jan. 01, 2008
Schwarzbeck Horn_Antenna	BBHA 9170	BBHA9170153	Jan. 25, 2008
TRILOG Broad Band Antenna	VULB 9168	138	July 26, 2008
RF Switches (ARNITSU)	CS-201	1565157	Aug. 13, 2008
RF CABLE (Chaintek)	SF102	22054-2	Nov. 14. 2008
RF Cable(RICHTEC)	9913-30M N-N Cable	STCCAB-30M-1 GHz	Aug. 13, 2008
Software	ADT_Radiated_V 7.6.15.7	NA	NA
CHANCE MOST Antenna Tower	AT-100	0203	NA
CHANCE MOST Turn Table	TT-100	0203	NA

- Note: 1. The calibration interval of the above test instruments is 12 months and the calibrations are traceable to NML/ROC and NIST/USA.  
 2. The horn antenna, HP preamplifier (model: 8449B) and Spectrum Analyzer (model: R3271A) are used only for the measurement of emission frequency above 1GHz if tested.  
 3. The test was performed in ADT Open Site No. C.  
 4. The FCC Site Registration No. is 656396.  
 5. The VCCI Site Registration No. is R-1626.  
 6. The CANADA Site Registration No. is IC 4824A-3.

#### 4.2.4 TEST PROCEDURES

- a. The EUT was placed on the top of a rotating table 0.8 meters above the ground at a 3 meter semi-anechoic chamber. The table was rotated 360 degrees to determine the position of the highest radiation.
- b. The EUT was set 3 meters away from the interference-receiving antenna, which was mounted on the top of a variable-height antenna tower.
- c. The antenna is a broadband antenna, and its height is varied from one meter to four meters above the ground to determine the maximum value of the field strength. Both horizontal and vertical polarizations of the antenna are set to make the measurement.
- d. For each suspected emission, the EUT was arranged to its worst case and then the antenna was tuned to heights from 1 meter to 4 meters and the rotatable table was turned from 0 degrees to 360 degrees to find the maximum reading.
- e. The test-receiver system was set to Peak Detect Function and Specified Bandwidth with Maximum Hold Mode.
- f. If the emission level of the EUT in peak mode was 10dB lower than the limit specified, then testing could be stopped and the peak values of the EUT would be reported. Otherwise the emissions that did not have 10dB margin would be re-tested one by one using peak, quasi-peak or average method as specified and then reported in a data sheet.

**NOTE:**

1. The resolution bandwidth and video bandwidth of test receiver/spectrum analyzer is 120kHz for Peak detection (PK) and Quasi-peak detection (QP) at frequency below 1GHz.
2. The resolution bandwidth of test receiver/spectrum analyzer is 1 MHz and the video bandwidth is 3 MHz for Peak detection (PK) at frequency above 1GHz.
3. The resolution bandwidth of test receiver/spectrum analyzer is 1 MHz and the video bandwidth is 10 Hz for Average detection (AV) at frequency above 1GHz.

#### 4.2.5 DEVIATION FROM TEST STANDARD

No deviation



#### 4.2.6 TEST SETUP

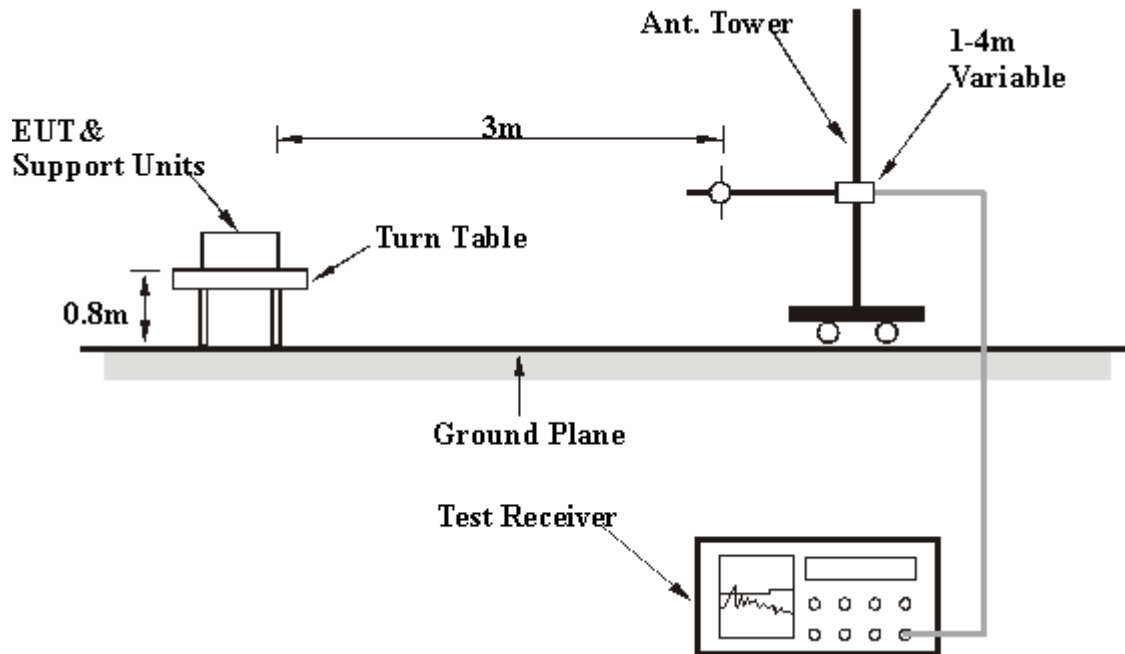

For the actual test configuration, please refer to the related item – Photographs of the Test Configuration.

#### 4.2.7 EUT OPERATING CONDITION

Same as 4.1.6



## Below 1GHz Test Data

### 4.2.8 TEST RESULTS

#### 802.11n (20MHz) OFDM MODULATION:

EUT TEST CONDITION		MEASUREMENT DETAIL	
CHANNEL	Channel 1	FREQUENCY RANGE	Below 1000MHz
INPUT POWER (SYSTEM)	120Vac, 60 Hz	DETECTOR FUNCTION	Quasi-Peak
ENVIRONMENTAL CONDITIONS	26deg. C, 68%RH, 971hPa	TESTED BY	Sky Liao

ANTENNA POLARITY & TEST DISTANCE: HORIZONTAL AT 3 M								
NO.	FREQ. (MHz)	EMISSION LEVEL (dBuV/m)	LIMIT (dBuV/m)	MARGIN (dB)	ANTENNA HEIGHT (m)	TABLE ANGLE (Degree)	RAW VALUE (dBuV)	CORRECTION FACTOR (dB/m)
1	80.00	35.60 QP	40.00	-4.40	2.08 H	52	25.46	10.14
2	120.00	40.60 QP	43.50	-2.90	2.02 H	218	28.78	11.82
3	240.00	24.20 QP	46.00	-21.80	1.24 H	36	10.86	13.34
4	360.00	23.40 QP	46.00	-22.60	1.02 H	228	5.69	17.71
5	480.00	27.90 QP	46.00	-18.10	1.40 H	220	6.65	21.25
6	600.00	27.20 QP	46.00	-18.80	1.38 H	185	2.72	24.48
7	840.00	31.20 QP	46.00	-14.80	1.08 H	48	2.97	28.23
8	960.00	41.20 QP	46.00	-4.80	1.16 H	186	11.31	29.89

ANTENNA POLARITY & TEST DISTANCE: VERTICAL AT 3 M								
NO.	FREQ. (MHz)	EMISSION LEVEL (dBuV/m)	LIMIT (dBuV/m)	MARGIN (dB)	ANTENNA HEIGHT (m)	TABLE ANGLE (Degree)	RAW VALUE (dBuV)	CORRECTION FACTOR (dB/m)
1	80.00	33.60 QP	40.00	-6.40	1.00 V	345	23.46	10.14
2	120.00	36.40 QP	43.50	-7.10	1.00 V	138	24.58	11.82
3	200.00	24.80 QP	43.50	-18.70	1.00 V	268	13.20	11.60
4	360.00	23.60 QP	46.00	-22.40	1.25 V	308	5.89	17.71
5	480.00	25.90 QP	46.00	-20.10	1.00 V	48	4.65	21.25
6	600.00	24.00 QP	46.00	-22.00	1.28 V	40	-0.48	24.48
7	840.00	28.20 QP	46.00	-17.80	1.22 V	266	-0.03	28.23
8	960.00	37.90 QP	46.00	-8.10	1.16 V	182	8.01	29.89

- REMARKS:**
1. Emission level (dBuV/m) = Raw Value (dBuV) + Correction Factor (dB/m).
  2. Correction Factor (dB/m) = Antenna Factor (dB/m) + Cable Factor (dB).
  3. The other emission levels were very low against the limit.
  4. Margin value = Emission level – Limit value.

## Above 1GHz Test Data

### 4.2.9 TEST RESULTS

#### 802.11a OFDM MODULATION:

EUT TEST CONDITION		MEASUREMENT DETAIL	
CHANNEL	Channel 1	FREQUENCY RANGE	1 ~ 40 GHz
INPUT POWER (SYSTEM)	120Vac, 60 Hz	DETECTOR FUNCTION	Peak(PK) Average (AV)
ENVIRONMENTAL CONDITIONS	19 deg. C, 70%RH, 972hPa	TESTED BY	Phoenix Huang

ANTENNA POLARITY & TEST DISTANCE: HORIZONTAL AT 3 M								
No.	Freq. (MHz)	Emission Level (dBuV/m)	Limit (dBuV/m)	Margin (dB)	Antenna Height (m)	Table Angle (Degree)	Raw Value (dBuV)	Correction Factor (dB/m)
1	#4144.00	56.30 PK	74.00	-17.70	1.10 H	204	22.35	33.95
2	#4144.00	48.20 AV	54.00	-5.80	1.10 H	204	14.25	33.95
3	#5148.70	59.30 PK	74.00	-14.70	1.07 H	328	23.06	36.24
4	#5148.70	45.90 AV	54.00	-8.10	1.07 H	328	9.66	36.24
5	*5180.00	106.70 PK			1.09 H	349	70.42	36.28
6	*5180.00	96.30 AV			1.09 H	349	60.02	36.28
7	#8288.00	56.80 PK	74.00	-17.20	1.28 H	54	12.58	44.22
8	#8288.00	50.30 AV	54.00	-3.70	1.28 H	54	6.08	44.22
9	10360.00	59.20 PK	88.30	-29.10	1.59 H	21	13.30	45.90
10	10360.00	46.10 AV	68.30	-22.20	1.59 H	21	0.20	45.90

ANTENNA POLARITY & TEST DISTANCE: VERTICAL AT 3 M								
No.	Freq. (MHz)	Emission Level (dBuV/m)	Limit (dBuV/m)	Margin (dB)	Antenna Height (m)	Table Angle (Degree)	Raw Value (dBuV)	Correction Factor (dB/m)
1	#4144.00	56.90 PK	74.00	-17.10	1.17 V	93	22.95	33.95
2	#4144.00	48.80 AV	54.00	-5.20	1.17 V	93	14.85	33.95
3	#5148.70	60.80 PK	74.00	-13.20	1.13 V	143	24.56	36.24
4	#5148.70	47.60 AV	54.00	-6.40	1.13 V	143	11.36	36.24
5	*5180.00	110.30 PK			1.15 V	115	74.02	36.28
6	*5180.00	99.90 AV			1.15 V	115	63.62	36.28
7	#8288.00	54.00 PK	74.00	-20.00	1.27 V	29	9.78	44.22
8	#8288.00	42.00 AV	54.00	-12.00	1.27 V	29	-2.22	44.22
9	10360.00	56.70 PK	88.30	-31.60	1.62 V	20	10.80	45.90
10	10360.00	44.00 AV	68.30	-24.30	1.62 V	20	-1.90	45.90

- NOTE:**
1. Emission level(dBuV/m)=Raw Value(dBuV) + Correction Factor(dB/m)
  2. Correction Factor(dB/m) = Antenna Factor (dB/m) + Cable Factor (dB)
  3. The other emission levels were very low against the limit.
  4. Margin value = Emission level – Limit value
  5. "\*" : Fundamental frequency
  6. "#"The radiated frequency falling in the restricted band.

EUT TEST CONDITION		MEASUREMENT DETAIL	
CHANNEL	Channel 4	FREQUENCY RANGE	1 ~ 40 GHz
INPUT POWER (SYSTEM)	120Vac, 60 Hz	DETECTOR FUNCTION	Peak(PK) Average (AV)
ENVIRONMENTAL CONDITIONS	19 deg. C, 70%RH, 972hPa	TESTED BY	Phoenix Huang

ANTENNA POLARITY & TEST DISTANCE: HORIZONTAL AT 3 M								
No.	Freq. (MHz)	Emission Level (dBuV/m)	Limit (dBuV/m)	Margin (dB)	Antenna Height (m)	Table Angle (Degree)	Raw Value (dBuV)	Correction Factor (dB/m)
1	#4192.00	54.80 PK	74.00	-19.20	1.36 H	231	20.70	34.10
2	#4192.00	46.80 AV	54.00	-7.20	1.36 H	231	12.70	34.10
3	*5240.00	107.64 PK			1.10 H	29	71.29	36.35
4	*5240.00	97.11 AV			1.10 H	29	60.76	36.35
5	#8384.00	56.80 PK	74.00	-17.20	1.24 H	54	12.63	44.17
6	#8384.00	50.00 AV	54.00	-4.00	1.24 H	54	5.83	44.17
7	10480.00	59.80 PK	88.30	-28.50	1.07 H	306	13.69	46.11
8	10480.00	45.80 AV	68.30	-22.50	1.07 H	306	-0.31	46.11

ANTENNA POLARITY & TEST DISTANCE: VERTICAL AT 3 M								
No.	Freq. (MHz)	Emission Level (dBuV/m)	Limit (dBuV/m)	Margin (dB)	Antenna Height (m)	Table Angle (Degree)	Raw Value (dBuV)	Correction Factor (dB/m)
1	#4192.00	55.00 PK	74.00	-19.00	1.33 V	97	20.90	34.10
2	#4192.00	44.30 AV	54.00	-9.70	1.33 V	97	10.20	34.10
3	*5240.00	109.10 PK			1.10 V	95	72.75	36.35
4	*5240.00	98.70 AV			1.10 V	95	62.35	36.35
5	#8384.00	54.70 PK	74.00	-19.30	1.18 V	58	10.53	44.17
6	#8384.00	45.00 AV	54.00	-9.00	1.18 V	58	0.83	44.17
7	10480.00	58.40 PK	88.30	-29.90	1.29 V	88	12.29	46.11
8	10480.00	44.71 AV	68.30	-23.59	1.29 V	88	-1.40	46.11

- NOTE:**
1. Emission level(dBuV/m)=Raw Value(dBuV) + Correction Factor(dB/m)
  2. Correction Factor(dB/m) = Antenna Factor (dB/m) + Cable Factor (dB)
  3. The other emission levels were very low against the limit.
  4. Margin value = Emission level – Limit value
  5. "\*" : Fundamental frequency
  6. "#"The radiated frequency falling in the restricted band.

EUT TEST CONDITION		MEASUREMENT DETAIL	
CHANNEL	Channel 5	FREQUENCY RANGE	1 ~ 40 GHz
INPUT POWER (SYSTEM)	120Vac, 60 Hz	DETECTOR FUNCTION	Peak(PK) Average (AV)
ENVIRONMENTAL CONDITIONS	19 deg. C, 70%RH, 972hPa	TESTED BY	Phoenix Huang

ANTENNA POLARITY & TEST DISTANCE: HORIZONTAL AT 3 M								
No.	Freq. (MHz)	Emission Level (dBuV/m)	Limit (dBuV/m)	Margin (dB)	Antenna Height (m)	Table Angle (Degree)	Raw Value (dBuV)	Correction Factor (dB/m)
1	#4208.00	56.40 PK	74.00	-17.60	1.40 H	239	22.26	34.14
2	#4208.00	48.60 AV	54.00	-5.40	1.40 H	239	14.46	34.14
3	*5260.00	106.53 PK			1.09 H	301	70.16	36.37
4	*5260.00	96.22 AV			1.09 H	301	59.85	36.37
5	#8416.00	57.90 PK	74.00	-16.10	1.21 H	132	13.75	44.15
6	#8416.00	51.20 AV	54.00	-2.80	1.21 H	132	7.05	44.15
7	10520.00	59.40 PK	88.30	-28.90	1.09 H	316	13.23	46.17
8	10520.00	45.30 AV	68.30	-23.00	1.09 H	316	-0.87	46.17

ANTENNA POLARITY & TEST DISTANCE: VERTICAL AT 3 M								
No.	Freq. (MHz)	Emission Level (dBuV/m)	Limit (dBuV/m)	Margin (dB)	Antenna Height (m)	Table Angle (Degree)	Raw Value (dBuV)	Correction Factor (dB/m)
1	#4208.00	57.40 PK	74.00	-16.60	1.32 V	59	23.26	34.14
2	#4208.00	49.87 AV	54.00	-4.13	1.32 V	59	15.73	34.14
3	*5260.00	108.00 PK			1.39 V	97	71.63	36.37
4	*5260.00	97.30 AV			1.39 V	97	60.93	36.37
5	#8416.00	55.18 PK	74.00	-18.82	1.10 V	29	11.03	44.15
6	#8416.00	41.55 AV	54.00	-12.45	1.10 V	29	-2.60	44.15
7	10520.00	58.60 PK	88.30	-29.70	1.30 V	29	12.43	46.17
8	10520.00	44.12 AV	68.30	-24.18	1.30 V	29	-2.05	46.17

- NOTE:**
1. Emission level(dBuV/m)=Raw Value(dBuV) + Correction Factor(dB/m)
  2. Correction Factor(dB/m) = Antenna Factor (dB/m) + Cable Factor (dB)
  3. The other emission levels were very low against the limit.
  4. Margin value = Emission level – Limit value
  5. "\*" : Fundamental frequency
  6. "#"The radiated frequency falling in the restricted band.

EUT TEST CONDITION		MEASUREMENT DETAIL	
CHANNEL	Channel 8	FREQUENCY RANGE	1 ~ 40 GHz
INPUT POWER (SYSTEM)	120Vac, 60 Hz	DETECTOR FUNCTION	Peak(PK) Average (AV)
ENVIRONMENTAL CONDITIONS	19 deg. C, 70%RH, 972hPa	TESTED BY	Phoenix Huang

ANTENNA POLARITY & TEST DISTANCE: HORIZONTAL AT 3 M								
No.	Freq. (MHz)	Emission Level (dBuV/m)	Limit (dBuV/m)	Margin (dB)	Antenna Height (m)	Table Angle (Degree)	Raw Value (dBuV)	Correction Factor (dB/m)
1	#4256.00	56.20 PK	74.00	-17.80	1.28 H	243	21.91	34.29
2	#4256.00	48.20 AV	54.00	-5.80	1.28 H	243	13.91	34.29
3	*5320.00	107.61 PK			1.19 H	236	71.17	36.44
4	*5320.00	97.41 AV			1.19 H	236	60.97	36.44
5	#5350.00	57.47 PK	74.00	-16.53	1.27 H	203	20.99	36.48
6	#5350.00	38.99 AV	54.00	-15.01	1.27 H	203	2.51	36.48
7	#10640.00	58.50 PK	74.00	-15.50	1.69 H	36	12.21	46.29
8	#10640.00	45.70 AV	54.00	-8.30	1.69 H	36	-0.59	46.29

ANTENNA POLARITY & TEST DISTANCE: VERTICAL AT 3 M								
No.	Freq. (MHz)	Emission Level (dBuV/m)	Limit (dBuV/m)	Margin (dB)	Antenna Height (m)	Table Angle (Degree)	Raw Value (dBuV)	Correction Factor (dB/m)
1	#4256.00	56.93 PK	74.00	-17.07	1.53 V	27	22.64	34.29
2	#4256.00	49.31 AV	54.00	-4.69	1.53 V	27	15.02	34.29
3	*5320.00	108.30 PK			1.12 V	98	71.86	36.44
4	*5320.00	98.00 AV			1.12 V	98	61.56	36.44
5	#5350.00	58.60 PK	74.00	-15.40	1.36 V	97	22.12	36.48
6	#5350.00	45.51 AV	54.00	-8.49	1.36 V	97	9.03	36.48
7	#10640.00	57.63 PK	74.00	-16.37	1.57 V	81	11.34	46.29
8	#10640.00	43.18 AV	54.00	-10.82	1.57 V	81	-3.11	46.29

- NOTE:**
1. Emission level(dBuV/m)=Raw Value(dBuV) + Correction Factor(dB/m)
  2. Correction Factor(dB/m) = Antenna Factor (dB/m) + Cable Factor (dB)
  3. The other emission levels were very low against the limit.
  4. Margin value = Emission level – Limit value
  5. "\*" : Fundamental frequency
  6. "#"The radiated frequency falling in the restricted band.

EUT TEST CONDITION		MEASUREMENT DETAIL	
CHANNEL	Channel 9	FREQUENCY RANGE	1 ~ 40 GHz
INPUT POWER (SYSTEM)	120Vac, 60 Hz	DETECTOR FUNCTION	Peak(PK) Average (AV)
ENVIRONMENTAL CONDITIONS	19 deg. C, 70%RH, 972hPa	TESTED BY	Phoenix Huang

ANTENNA POLARITY & TEST DISTANCE: HORIZONTAL AT 3 M								
No.	Freq. (MHz)	Emission Level (dBuV/m)	Limit (dBuV/m)	Margin (dB)	Antenna Height (m)	Table Angle (Degree)	Raw Value (dBuV)	Correction Factor (dB/m)
1	#4400.00	55.50 PK	74.00	-18.50	1.44 H	0	20.78	34.72
2	#4400.00	45.80 AV	54.00	-8.20	1.44 H	0	11.08	34.72
3	#5443.00	48.96 PK	74.00	-25.04	2.10 H	358	12.37	36.59
4	#5443.00	35.93 AV	54.00	-18.07	2.10 H	358	-0.66	36.59
5	*5500.00	99.42 PK			1.00 H	269	62.76	36.66
6	*5500.00	87.63 AV			1.00 H	269	50.97	36.66
7	#11000.00	55.50 PK	74.00	-18.50	1.59 H	137	8.85	46.65
8	#11000.00	42.30 AV	54.00	-11.70	1.59 H	137	-4.35	46.65

ANTENNA POLARITY & TEST DISTANCE: VERTICAL AT 3 M								
No.	Freq. (MHz)	Emission Level (dBuV/m)	Limit (dBuV/m)	Margin (dB)	Antenna Height (m)	Table Angle (Degree)	Raw Value (dBuV)	Correction Factor (dB/m)
1	#4400.00	56.98 PK	74.00	-17.02	1.21 V	92	22.26	34.72
2	#4400.00	49.34 AV	54.00	-4.66	1.21 V	92	14.62	34.72
3	#5443.00	57.90 PK	74.00	-16.10	1.18 V	108	21.30	36.60
4	#5443.00	45.74 AV	54.00	-8.26	1.18 V	108	9.14	36.60
5	*5500.00	104.20 PK			1.30 V	107	67.54	36.66
6	*5500.00	93.50 AV			1.30 V	107	56.84	36.66
7	#11000.00	52.15 PK	74.00	-21.85	1.22 V	33	5.50	46.65
8	#11000.00	40.36 AV	54.00	-13.64	1.22 V	33	-6.29	46.65

- NOTE:**
1. Emission level(dBuV/m)=Raw Value(dBuV) + Correction Factor(dB/m)
  2. Correction Factor(dB/m) = Antenna Factor (dB/m) + Cable Factor (dB)
  3. The other emission levels were very low against the limit.
  4. Margin value = Emission level – Limit value
  5. "\*" : Fundamental frequency
  6. "#"The radiated frequency falling in the restricted band.

EUT TEST CONDITION		MEASUREMENT DETAIL	
CHANNEL	Channel 14	FREQUENCY RANGE	1 ~ 40 GHz
INPUT POWER (SYSTEM)	120Vac, 60 Hz	DETECTOR FUNCTION	Peak(PK) Average (AV)
ENVIRONMENTAL CONDITIONS	19 deg. C, 70%RH, 972hPa	TESTED BY	Phoenix Huang

ANTENNA POLARITY & TEST DISTANCE: HORIZONTAL AT 3 M								
No.	Freq. (MHz)	Emission Level (dBuV/m)	Limit (dBuV/m)	Margin (dB)	Antenna Height (m)	Table Angle (Degree)	Raw Value (dBuV)	Correction Factor (dB/m)
1	4480.00	55.50 PK	88.30	-32.80	1.45 H	212	20.54	34.96
2	4480.00	45.40 AV	68.30	-22.90	1.45 H	212	10.44	34.96
3	*5600.00	99.40 PK			1.22 H	39	62.50	36.90
4	*5600.00	89.20 AV			1.22 H	39	52.30	36.90
5	#11200.00	54.30 PK	74.00	-19.70	1.16 H	36	7.50	46.80
6	#11200.00	40.90 AV	54.00	-13.10	1.16 H	36	-5.90	46.80

ANTENNA POLARITY & TEST DISTANCE: VERTICAL AT 3 M								
No.	Freq. (MHz)	Emission Level (dBuV/m)	Limit (dBuV/m)	Margin (dB)	Antenna Height (m)	Table Angle (Degree)	Raw Value (dBuV)	Correction Factor (dB/m)
1	4480.00	54.60 PK	88.30	-33.70	1.40 V	261	19.64	34.96
2	4480.00	48.23 AV	68.30	-20.07	1.40 V	261	13.27	34.96
3	*5600.00	104.00 PK			1.13 V	107	67.10	36.90
4	*5600.00	93.50 AV			1.13 V	107	56.60	36.90
5	#11200.00	54.22 PK	74.00	-19.78	1.60 V	43	7.42	46.80
6	#11200.00	40.19 AV	54.00	-13.81	1.60 V	43	-6.61	46.80

- NOTE:**
1. Emission level(dBuV/m)=Raw Value(dBuV) + Correction Factor(dB/m)
  2. Correction Factor(dB/m) = Antenna Factor (dB/m) + Cable Factor (dB)
  3. The other emission levels were very low against the limit.
  4. Margin value = Emission level – Limit value
  5. "\*" : Fundamental frequency
  6. "#"The radiated frequency falling in the restricted band.



EUT TEST CONDITION		MEASUREMENT DETAIL	
CHANNEL	Channel 19	FREQUENCY RANGE	1 ~ 40 GHz
INPUT POWER (SYSTEM)	120Vac, 60 Hz	DETECTOR FUNCTION	Peak(PK) Average (AV)
ENVIRONMENTAL CONDITIONS	19 deg. C, 70%RH, 972hPa	TESTED BY	Phoenix Huang

ANTENNA POLARITY & TEST DISTANCE: HORIZONTAL AT 3 M								
No.	Freq. (MHz)	Emission Level (dBuV/m)	Limit (dBuV/m)	Margin (dB)	Antenna Height (m)	Table Angle (Degree)	Raw Value (dBuV)	Correction Factor (dB/m)
1	#4560.00	58.70 PK	74.00	-15.30	1.24 H	355	23.56	35.14
2	#4560.00	51.80 AV	54.00	-2.20	1.24 H	355	16.66	35.14
3	*5700.00	101.70 PK			1.59 H	293	64.55	37.15
4	*5700.00	91.34 AV			1.59 H	293	54.19	37.15
5	#9120.00	59.90 PK	74.00	-14.10	1.18 H	234	15.16	44.74
6	#9120.00	53.50 AV	54.00	-0.50	1.18 H	234	8.76	44.74
7	#11400.00	69.20 PK	74.00	-4.80	1.17 H	326	22.25	46.95
8	#11400.00	52.30 AV	54.00	-1.70	1.17 H	326	5.35	46.95

ANTENNA POLARITY & TEST DISTANCE: VERTICAL AT 3 M								
No.	Freq. (MHz)	Emission Level (dBuV/m)	Limit (dBuV/m)	Margin (dB)	Antenna Height (m)	Table Angle (Degree)	Raw Value (dBuV)	Correction Factor (dB/m)
1	#4560.00	59.63 PK	74.00	-14.37	1.49 V	77	24.49	35.14
2	#4560.00	52.19 AV	54.00	-1.81	1.49 V	77	17.05	35.14
3	*5700.00	107.00 PK			1.27 V	61	69.85	37.15
4	*5700.00	96.50 AV			1.27 V	61	59.35	37.15
5	#9120.00	60.34 PK	74.00	-13.66	1.27 V	93	15.60	44.74
6	#9120.00	52.81 AV	54.00	-1.19	1.27 V	93	8.07	44.74
7	#11400.00	68.48 PK	74.00	-5.52	1.50 V	124	21.53	46.95
8	#11400.00	51.20 AV	54.00	-2.80	1.50 V	124	4.25	46.95

- NOTE:**
1. Emission level(dBuV/m)=Raw Value(dBuV) + Correction Factor(dB/m)
  2. Correction Factor(dB/m) = Antenna Factor (dB/m) + Cable Factor (dB)
  3. The other emission levels were very low against the limit.
  4. Margin value = Emission level – Limit value
  5. "\*" : Fundamental frequency
  6. "#"The radiated frequency falling in the restricted band.

RESTRICTED BANDEDGE (802.11a MODE, CH1, HORIZONTAL)

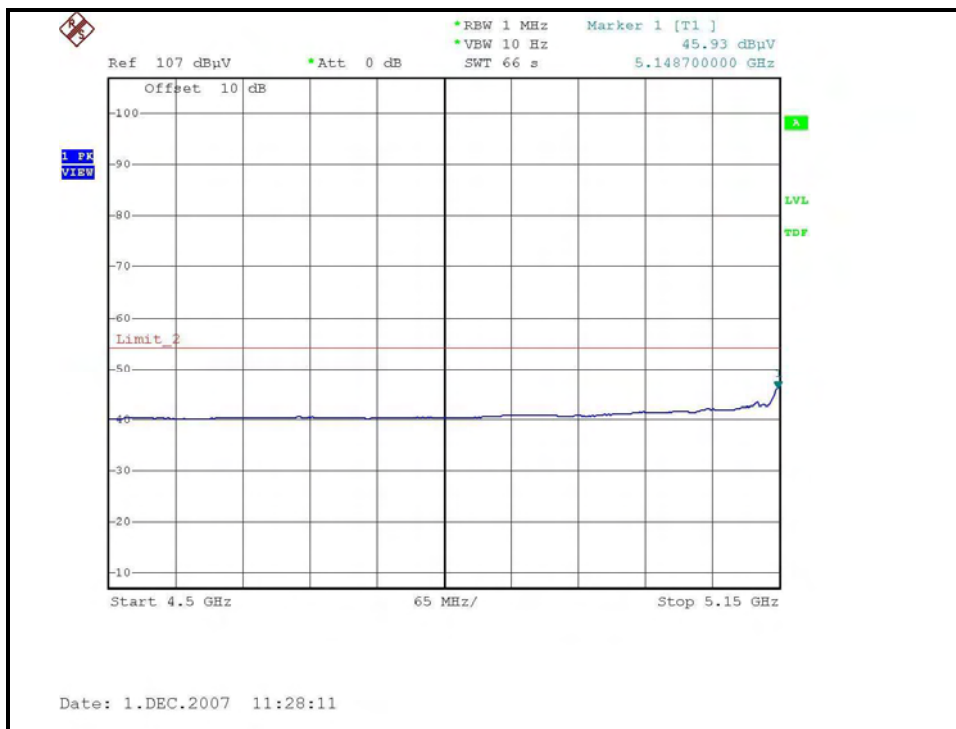
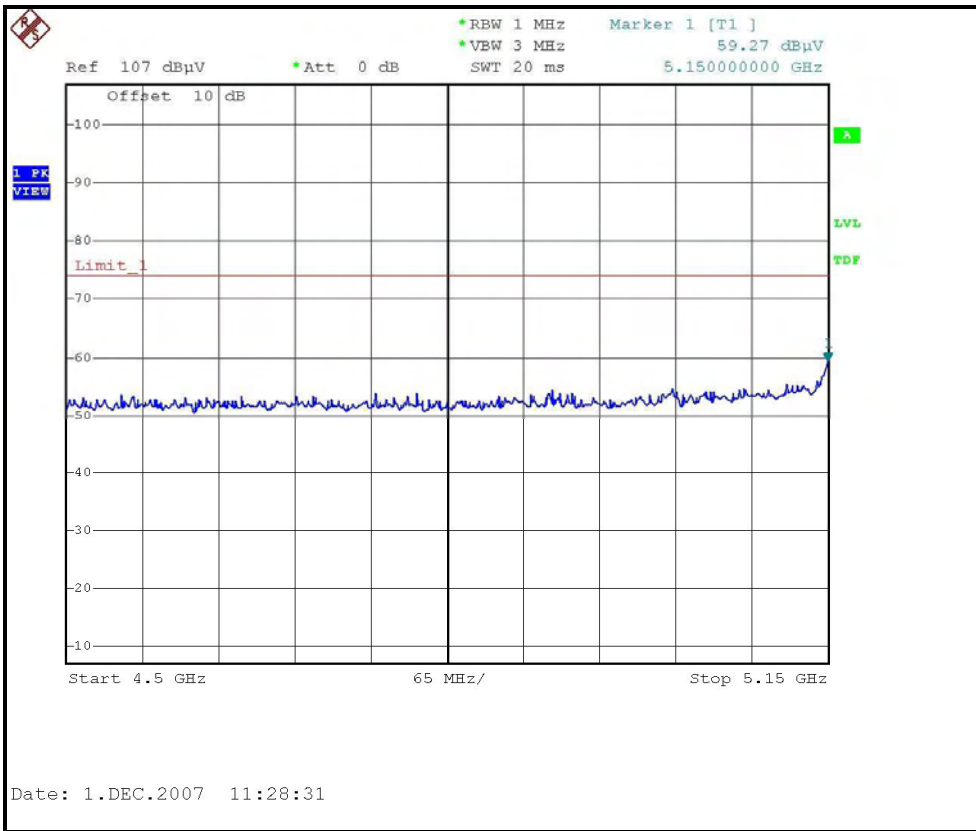

RESTRICTED BANDEDGE (802.11a MODE, CH1, VERTICAL)

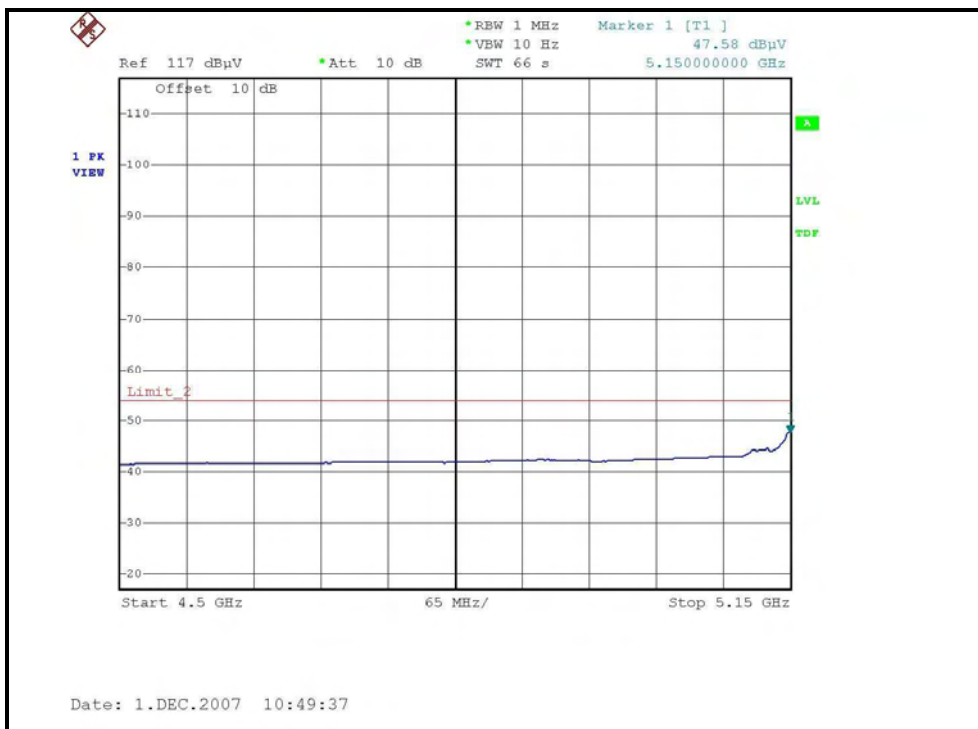
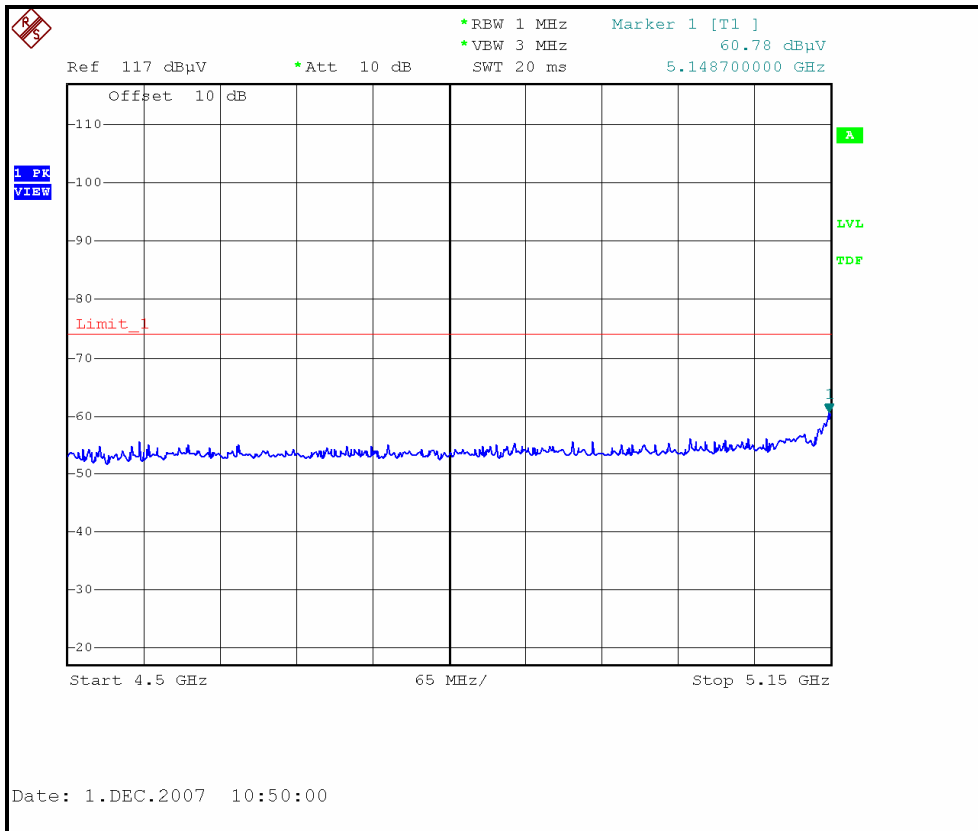

RESTRICTED BANDEDGE (802.11a MODE, CH8, HORIZONTAL)

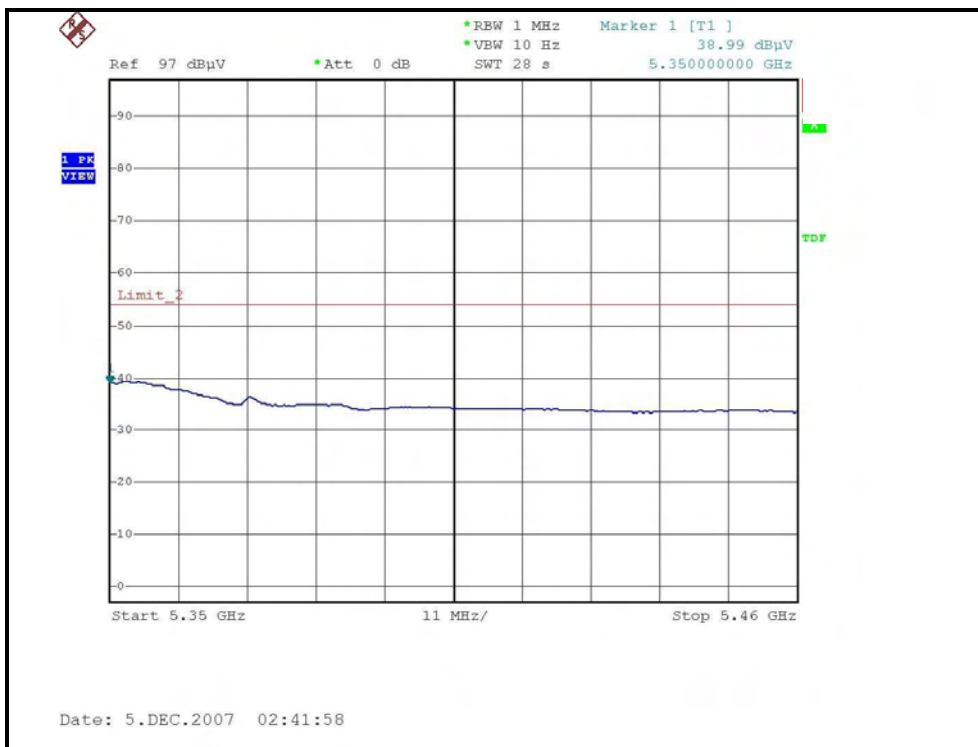
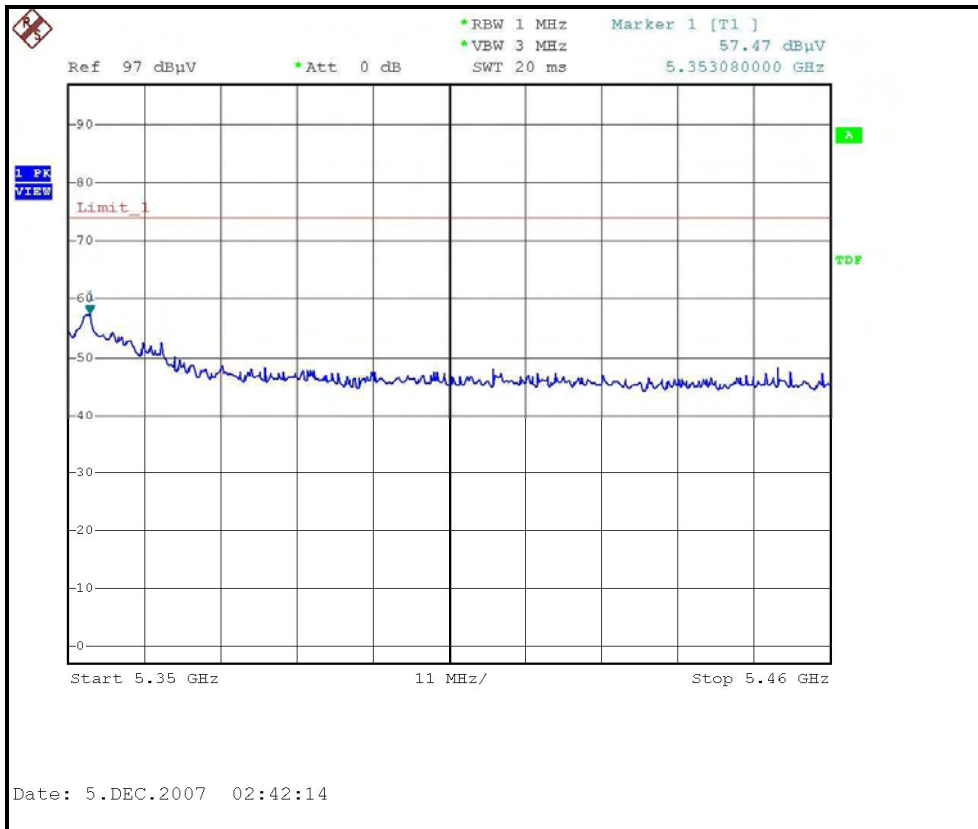



RESTRICTED BANDEdge (802.11a MODE, CH8, VERTICAL)

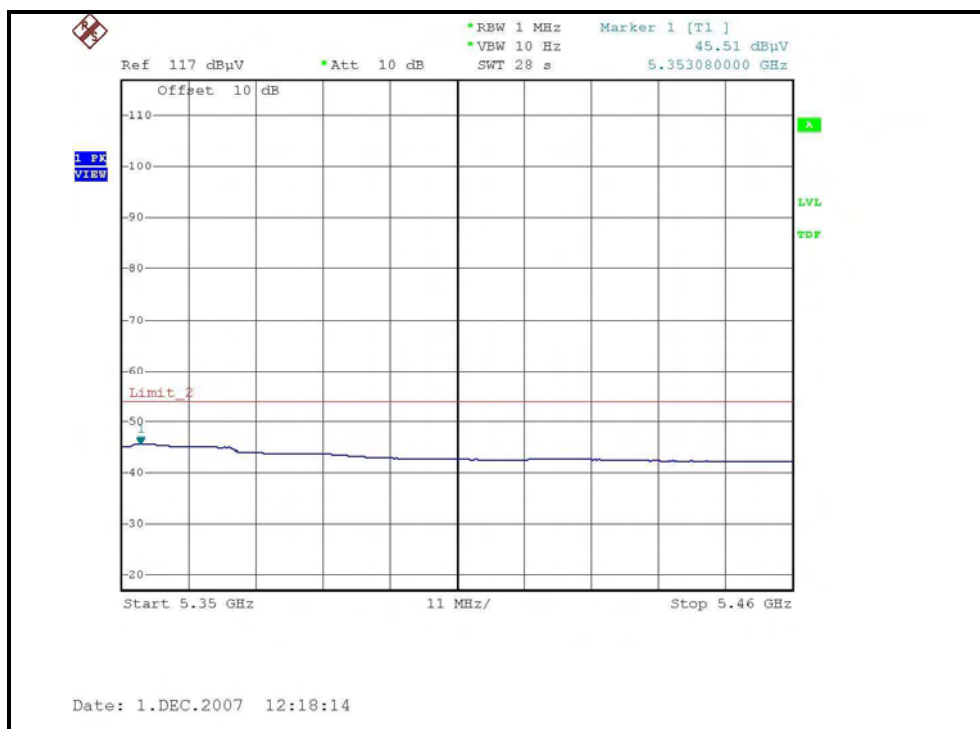
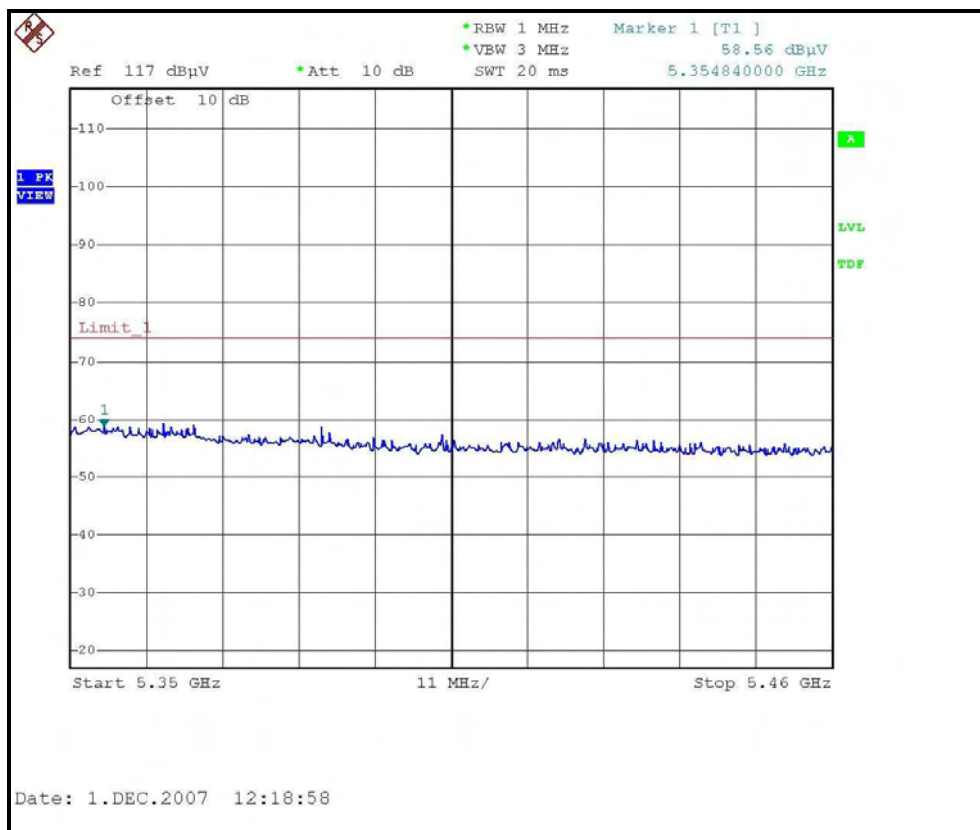

RESTRICTED BANDEDGE (802.11a MODE, CH9, HORIZONTAL)

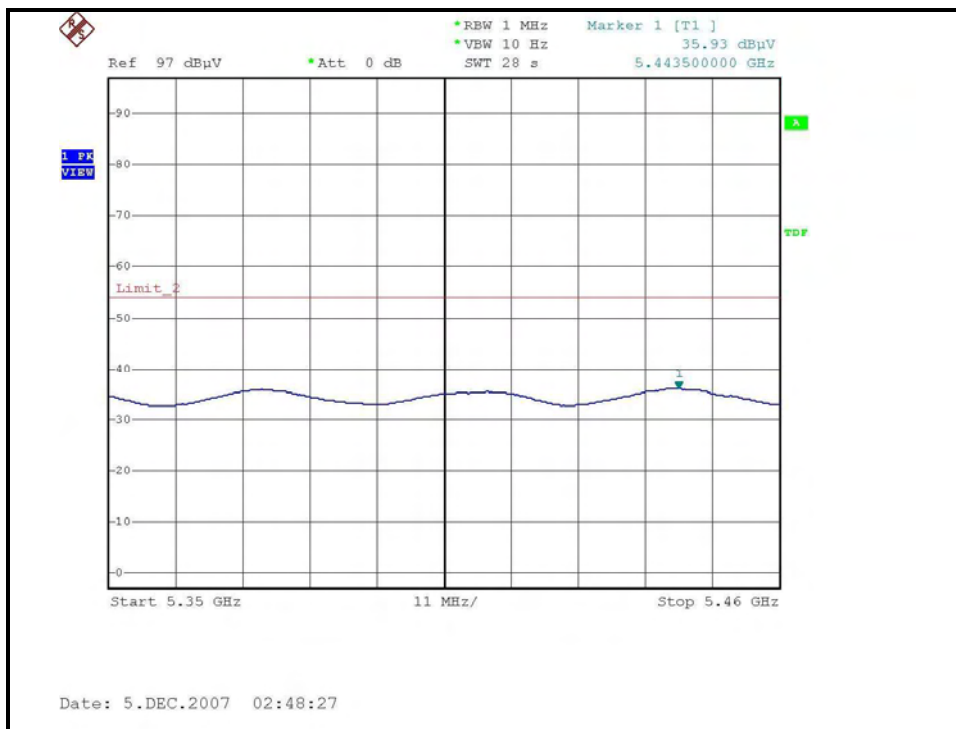
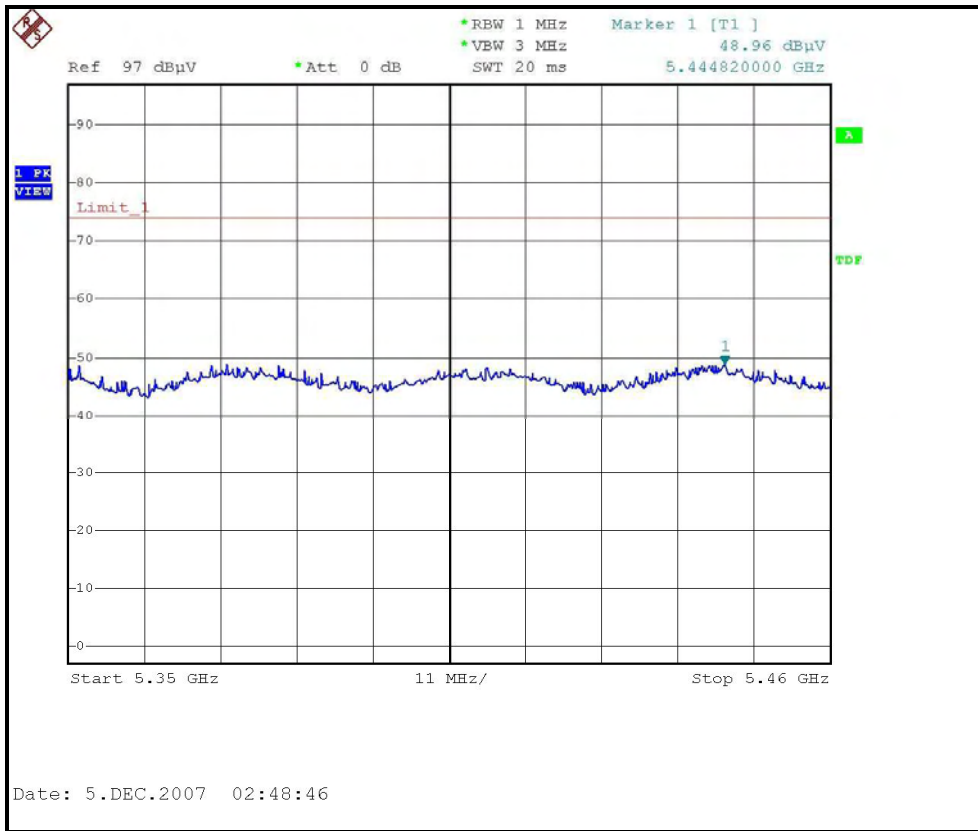

RESTRICTED BANDEDGE (802.11a MODE, CH9, VERTICAL)

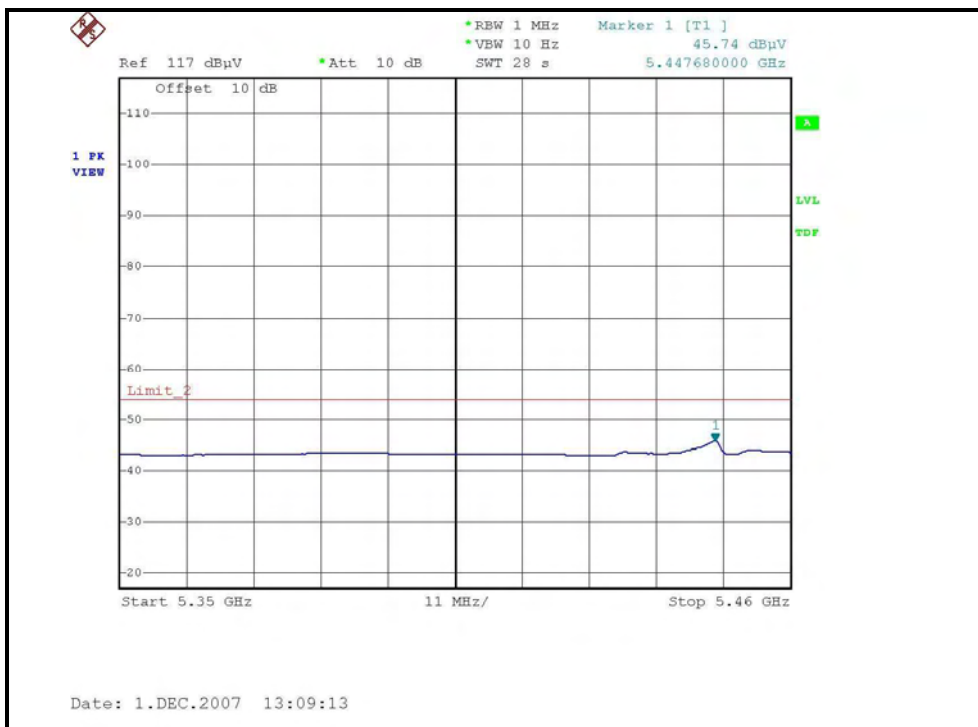
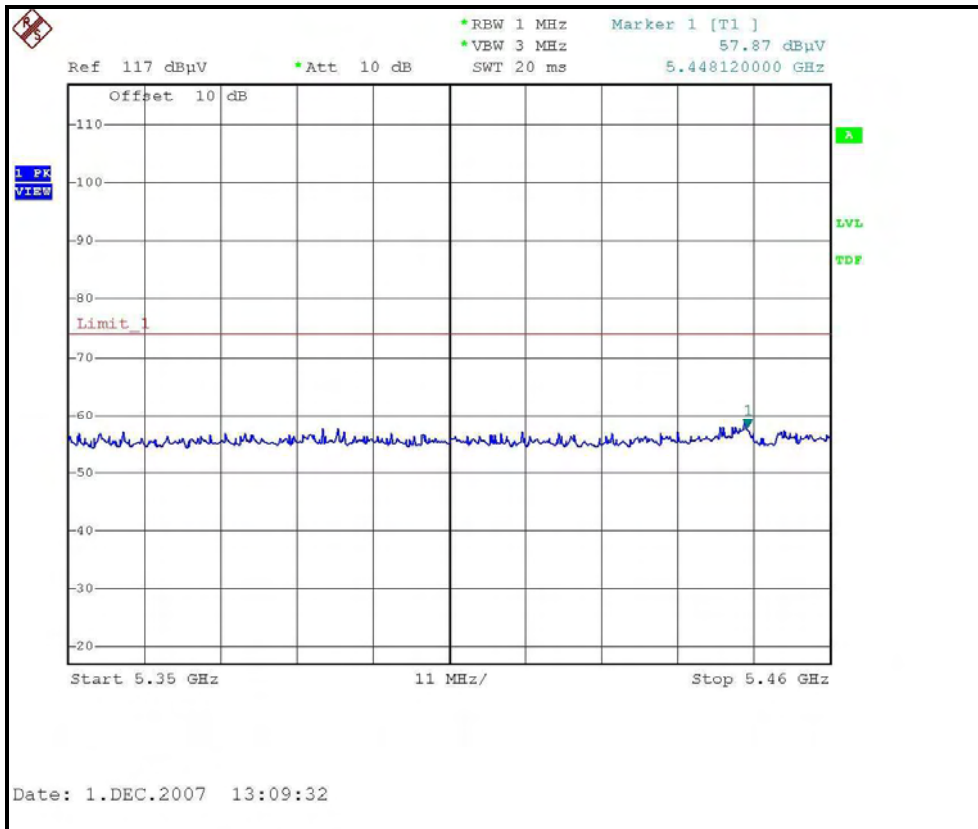

### DRAFT 802.11n (20MHz) OFDM MODULATION:

EUT TEST CONDITION		MEASUREMENT DETAIL	
CHANNEL	Channel 1	FREQUENCY RANGE	1 ~ 40 GHz
INPUT POWER (SYSTEM)	120Vac, 60 Hz	DETECTOR FUNCTION	Peak(PK) Average (AV)
ENVIRONMENTAL CONDITIONS	19 deg. C, 70%RH, 972hPa	TESTED BY	Phoenix Huang

ANTENNA POLARITY & TEST DISTANCE: HORIZONTAL AT 3 M								
No.	Freq. (MHz)	Emission Level (dBuV/m)	Limit (dBuV/m)	Margin (dB)	Antenna Height (m)	Table Angle (Degree)	Raw Value (dBuV)	Correction Factor (dB/m)
1	#4144.00	55.30 PK	74.00	-18.70	1.26 H	187	21.35	33.95
2	#4144.00	47.30 AV	54.00	-6.70	1.26 H	187	13.35	33.95
3	#5147.00	49.07 PK	74.00	-24.93	1.14 H	358	12.83	36.24
4	#5147.00	38.68 AV	54.00	-15.32	1.14 H	358	2.44	36.24
5	*5180.00	100.12 PK			1.10 H	47	63.84	36.28
6	*5180.00	90.70 AV			1.10 H	47	54.42	36.28
7	#8288.00	56.10 PK	74.00	-17.90	1.18 H	101	11.88	44.22
8	#8288.00	49.50 AV	54.00	-4.50	1.18 H	101	5.28	44.22
9	10360.00	56.90 PK	88.30	-31.40	1.50 H	158	11.00	45.90
10	10360.00	43.00 AV	68.30	-25.30	1.50 H	158	-2.90	45.90

ANTENNA POLARITY & TEST DISTANCE: VERTICAL AT 3 M								
No.	Freq. (MHz)	Emission Level (dBuV/m)	Limit (dBuV/m)	Margin (dB)	Antenna Height (m)	Table Angle (Degree)	Raw Value (dBuV)	Correction Factor (dB/m)
1	#4144.00	57.63 PK	74.00	-16.37	1.59 V	226	23.68	33.95
2	#4144.00	49.21 AV	54.00	-4.79	1.59 V	226	15.26	33.95
3	#5147.00	65.10 PK	74.00	-8.90	1.12 V	247	28.86	36.24
4	#5147.00	52.60 AV	54.00	-1.40	1.12 V	247	16.36	36.24
5	*5180.00	106.60 PK			1.22 V	252	70.32	36.28
6	*5180.00	94.60 AV			1.22 V	252	58.32	36.28
7	#8288.00	53.22 PK	74.00	-20.78	1.47 V	30	9.00	44.22
8	#8288.00	46.31 AV	54.00	-7.69	1.47 V	30	2.09	44.22
9	10360.00	55.31 PK	88.30	-32.99	1.60 V	199	9.41	45.90
10	10360.00	42.14 AV	68.30	-26.16	1.60 V	199	-3.76	45.90

- NOTE:**
1. Emission level(dBuV/m)=Raw Value(dBuV) + Correction Factor(dB/m)
  2. Correction Factor(dB/m) = Antenna Factor (dB/m) + Cable Factor (dB)
  3. The other emission levels were very low against the limit.
  4. Margin value = Emission level – Limit value
  5. "\*" : Fundamental frequency
  6. "#”The radiated frequency falling in the restricted band.



EUT TEST CONDITION		MEASUREMENT DETAIL	
CHANNEL	Channel 4	FREQUENCY RANGE	1 ~ 40 GHz
INPUT POWER (SYSTEM)	120Vac, 60 Hz	DETECTOR FUNCTION	Peak(PK) Average (AV)
ENVIRONMENTAL CONDITIONS	19 deg. C, 70%RH, 972hPa	TESTED BY	Phoenix Huang

ANTENNA POLARITY & TEST DISTANCE: HORIZONTAL AT 3 M								
No.	Freq. (MHz)	Emission Level (dBuV/m)	Limit (dBuV/m)	Margin (dB)	Antenna Height (m)	Table Angle (Degree)	Raw Value (dBuV)	Correction Factor (dB/m)
1	#4192.00	56.30 PK	74.00	-17.70	1.58 H	192	22.20	34.10
2	#4192.00	48.60 AV	54.00	-5.40	1.58 H	192	14.50	34.10
3	*5240.00	102.34 PK			1.25 H	237	65.99	36.35
4	*5240.00	91.23 AV			1.25 H	237	54.88	36.35
5	#8384.00	57.70 PK	74.00	-16.30	1.23 H	107	13.53	44.17
6	#8384.00	49.80 AV	54.00	-4.20	1.23 H	107	5.63	44.17
7	10480.00	57.20 PK	88.30	-31.10	1.55 H	244	11.09	46.11
8	10480.00	43.80 AV	68.30	-24.50	1.55 H	244	-2.31	46.11

ANTENNA POLARITY & TEST DISTANCE: VERTICAL AT 3 M								
No.	Freq. (MHz)	Emission Level (dBuV/m)	Limit (dBuV/m)	Margin (dB)	Antenna Height (m)	Table Angle (Degree)	Raw Value (dBuV)	Correction Factor (dB/m)
1	#4192.00	56.28 PK	74.00	-17.72	1.29 V	38	22.18	34.10
2	#4192.00	49.31 AV	54.00	-4.69	1.29 V	38	15.21	34.10
3	*5240.00	108.10 PK			1.13 V	90	71.75	36.35
4	*5240.00	96.70 AV			1.13 V	90	60.35	36.35
5	#8384.00	55.26 PK	74.00	-18.74	1.34 V	189	11.09	44.17
6	#8384.00	48.74 AV	54.00	-5.26	1.34 V	189	4.57	44.17
7	10480.00	55.61 PK	88.30	-32.69	1.60 V	58	9.50	46.11
8	10480.00	42.13 AV	68.30	-26.17	1.60 V	58	-3.98	46.11

- NOTE:**
1. Emission level(dBuV/m)=Raw Value(dBuV) + Correction Factor(dB/m)
  2. Correction Factor(dB/m) = Antenna Factor (dB/m) + Cable Factor (dB)
  3. The other emission levels were very low against the limit.
  4. Margin value = Emission level – Limit value
  5. “\*” : Fundamental frequency
  6. “#”The radiated frequency falling in the restricted band.

EUT TEST CONDITION		MEASUREMENT DETAIL	
CHANNEL	Channel 5	FREQUENCY RANGE	1 ~ 40 GHz
INPUT POWER (SYSTEM)	120Vac, 60 Hz	DETECTOR FUNCTION	Peak(PK) Average (AV)
ENVIRONMENTAL CONDITIONS	19 deg. C, 70%RH, 972hPa	TESTED BY	Phoenix Huang

ANTENNA POLARITY & TEST DISTANCE: HORIZONTAL AT 3 M								
No.	Freq. (MHz)	Emission Level (dBuV/m)	Limit (dBuV/m)	Margin (dB)	Antenna Height (m)	Table Angle (Degree)	Raw Value (dBuV)	Correction Factor (dB/m)
1	#4208.00	57.00 PK	74.00	-17.00	1.40 H	230	22.86	34.14
2	#4208.00	49.30 AV	54.00	-4.70	1.40 H	230	15.16	34.14
3	*5260.00	99.72 PK			1.09 H	28	63.35	36.37
4	*5260.00	89.50 AV			1.09 H	28	53.13	36.37
5	#8416.00	57.00 PK	74.00	-17.00	1.22 H	132	12.85	44.15
6	#8416.00	50.60 AV	54.00	-3.40	1.22 H	132	6.45	44.15
7	10520.00	57.80 PK	88.30	-30.50	1.16 H	318	11.63	46.17
8	10520.00	45.00 AV	68.30	-23.30	1.16 H	318	-1.17	46.17

ANTENNA POLARITY & TEST DISTANCE: VERTICAL AT 3 M								
No.	Freq. (MHz)	Emission Level (dBuV/m)	Limit (dBuV/m)	Margin (dB)	Antenna Height (m)	Table Angle (Degree)	Raw Value (dBuV)	Correction Factor (dB/m)
1	#4208.00	57.15 PK	74.00	-16.85	1.90 V	226	23.01	34.14
2	#4208.00	48.41 AV	54.00	-5.59	1.90 V	226	14.27	34.14
3	*5260.00	106.30 PK			1.23 V	14	69.93	36.37
4	*5260.00	94.60 AV			1.23 V	14	58.23	36.37
5	#8416.00	56.83 PK	74.00	-17.17	1.59 V	68	12.68	44.15
6	#8416.00	49.34 AV	54.00	-4.66	1.59 V	68	5.19	44.15
7	10520.00	57.25 PK	88.30	-31.05	1.43 V	214	11.08	46.17
8	10520.00	44.31 AV	68.30	-23.99	1.43 V	214	-1.86	46.17

- NOTE:**
1. Emission level(dBuV/m)=Raw Value(dBuV) + Correction Factor(dB/m)
  2. Correction Factor(dB/m) = Antenna Factor (dB/m) + Cable Factor (dB)
  3. The other emission levels were very low against the limit.
  4. Margin value = Emission level – Limit value
  5. "\*" : Fundamental frequency
  6. "#"The radiated frequency falling in the restricted band.

EUT TEST CONDITION		MEASUREMENT DETAIL	
<b>CHANNEL</b>	Channel 8	<b>FREQUENCY RANGE</b>	1 ~ 40 GHz
<b>INPUT POWER (SYSTEM)</b>	120Vac, 60 Hz	<b>DETECTOR FUNCTION</b>	Peak(PK) Average (AV)
<b>ENVIRONMENTAL CONDITIONS</b>	19 deg. C, 70%RH, 972hPa	<b>TESTED BY</b>	Phoenix Huang

ANTENNA POLARITY & TEST DISTANCE: HORIZONTAL AT 3 M								
No.	Freq. (MHz)	Emission Level (dBuV/m)	Limit (dBuV/m)	Margin (dB)	Antenna Height (m)	Table Angle (Degree)	Raw Value (dBuV)	Correction Factor (dB/m)
1	#4256.00	56.40 PK	74.00	-17.60	1.24 H	244	22.11	34.29
2	#4256.00	48.00 AV	54.00	-6.00	1.24 H	244	13.71	34.29
3	*5320.00	103.30 PK			1.21 H	184	66.86	36.44
4	*5320.00	91.90 AV			1.21 H	184	55.46	36.44
5	#5372.00	51.85 PK	74.00	-22.15	1.23 H	138	15.34	36.51
6	#5372.00	38.20 AV	54.00	-15.80	1.23 H	138	1.69	36.51
7	#10640.00	57.40 PK	74.00	-16.60	1.65 H	318	11.11	46.29
8	#10640.00	43.30 AV	54.00	-10.70	1.65 H	318	-2.99	46.29

ANTENNA POLARITY & TEST DISTANCE: VERTICAL AT 3 M								
No.	Freq. (MHz)	Emission Level (dBuV/m)	Limit (dBuV/m)	Margin (dB)	Antenna Height (m)	Table Angle (Degree)	Raw Value (dBuV)	Correction Factor (dB/m)
1	#4256.00	57.88 PK	74.00	-16.12	1.48 V	25	23.59	34.29
2	#4256.00	50.38 AV	54.00	-3.62	1.48 V	25	16.09	34.29
3	*5320.00	105.60 PK			1.19 V	104	69.16	36.44
4	*5320.00	94.50 AV			1.19 V	104	58.06	36.44
5	#5372.00	62.10 PK	74.00	-11.90	1.35 V	291	25.62	36.48
6	#5372.00	48.00 AV	54.00	-6.00	1.35 V	291	11.52	36.48
7	#10640.00	55.69 PK	74.00	-18.31	1.37 V	268	9.40	46.29
8	#10640.00	42.24 AV	54.00	-11.76	1.37 V	268	-4.05	46.29

- NOTE:**
1. Emission level(dBuV/m)=Raw Value(dBuV) + Correction Factor(dB/m)
  2. Correction Factor(dB/m) = Antenna Factor (dB/m) + Cable Factor (dB)
  3. The other emission levels were very low against the limit.
  4. Margin value = Emission level – Limit value
  5. "\*" : Fundamental frequency
  6. "#"The radiated frequency falling in the restricted band.

EUT TEST CONDITION		MEASUREMENT DETAIL	
<b>CHANNEL</b>	Channel 9	<b>FREQUENCY RANGE</b>	1 ~ 40 GHz
<b>INPUT POWER (SYSTEM)</b>	120Vac, 60 Hz	<b>DETECTOR FUNCTION</b>	Peak(PK) Average (AV)
<b>ENVIRONMENTAL CONDITIONS</b>	19 deg. C, 70%RH, 972hPa	<b>TESTED BY</b>	Phoenix Huang

ANTENNA POLARITY & TEST DISTANCE: HORIZONTAL AT 3 M								
No.	Freq. (MHz)	Emission Level (dBuV/m)	Limit (dBuV/m)	Margin (dB)	Antenna Height (m)	Table Angle (Degree)	Raw Value (dBuV)	Correction Factor (dB/m)
1	#4400.00	56.10 PK	74.00	-17.90	1.12 H	187	21.38	34.72
2	#4400.00	46.30 AV	54.00	-7.70	1.12 H	187	11.58	34.72
3	#5441.00	50.28 PK	74.00	-23.72	2.09 H	12	13.69	36.59
4	#5441.00	36.97 AV	54.00	-17.03	2.09 H	12	0.38	36.59
5	*5500.00	99.75 PK			1.49 H	221	63.09	36.66
6	*5500.00	89.21 AV			1.49 H	221	52.55	36.66
7	#11000.00	57.90 PK	74.00	-16.10	1.13 H	110	11.25	46.65
8	#11000.00	44.10 AV	54.00	-9.90	1.13 H	110	-2.55	46.65

ANTENNA POLARITY & TEST DISTANCE: VERTICAL AT 3 M								
No.	Freq. (MHz)	Emission Level (dBuV/m)	Limit (dBuV/m)	Margin (dB)	Antenna Height (m)	Table Angle (Degree)	Raw Value (dBuV)	Correction Factor (dB/m)
1	#4400.00	56.39 PK	74.00	-17.61	1.18 V	263	21.67	34.72
2	#4400.00	48.45 AV	54.00	-5.55	1.18 V	263	13.73	34.72
3	#5441.00	58.90 PK	74.00	-15.10	1.09 V	90	22.30	36.60
4	#5441.00	46.70 AV	54.00	-7.30	1.09 V	90	10.10	36.60
5	*5500.00	104.80 PK			1.41 V	156	68.14	36.66
6	*5500.00	93.60 AV			1.41 V	156	56.94	36.66
7	#11000.00	57.96 PK	74.00	-16.04	1.50 V	29	11.31	46.65
8	#11000.00	43.21 AV	54.00	-10.79	1.50 V	29	-3.44	46.65

- NOTE:**
1. Emission level(dBuV/m)=Raw Value(dBuV) + Correction Factor(dB/m)
  2. Correction Factor(dB/m) = Antenna Factor (dB/m) + Cable Factor (dB)
  3. The other emission levels were very low against the limit.
  4. Margin value = Emission level – Limit value
  5. "\*" : Fundamental frequency
  6. "#"The radiated frequency falling in the restricted band.

EUT TEST CONDITION		MEASUREMENT DETAIL	
<b>CHANNEL</b>	Channel 14	<b>FREQUENCY RANGE</b>	1 ~ 40 GHz
<b>INPUT POWER (SYSTEM)</b>	120Vac, 60 Hz	<b>DETECTOR FUNCTION</b>	Peak(PK) Average (AV)
<b>ENVIRONMENTAL CONDITIONS</b>	19 deg. C, 70%RH, 972hPa	<b>TESTED BY</b>	Phoenix Huang

ANTENNA POLARITY & TEST DISTANCE: HORIZONTAL AT 3 M								
No.	Freq. (MHz)	Emission Level (dBuV/m)	Limit (dBuV/m)	Margin (dB)	Antenna Height (m)	Table Angle (Degree)	Raw Value (dBuV)	Correction Factor (dB/m)
1	4480.00	55.80 PK	88.30	-32.50	1.39 H	23	20.84	34.96
2	4480.00	45.70 AV	68.30	-22.60	1.39 H	23	10.74	34.96
3	*5600.00	98.63 PK			1.00 H	296	61.73	36.90
4	*5600.00	88.42 AV			1.00 H	296	51.52	36.90
5	#11200.00	56.80 PK	74.00	-17.20	1.45 H	274	10.00	46.80
6	#11200.00	43.70 AV	54.00	-10.30	1.45 H	274	-3.10	46.80

ANTENNA POLARITY & TEST DISTANCE: VERTICAL AT 3 M								
No.	Freq. (MHz)	Emission Level (dBuV/m)	Limit (dBuV/m)	Margin (dB)	Antenna Height (m)	Table Angle (Degree)	Raw Value (dBuV)	Correction Factor (dB/m)
1	4480.00	55.17 PK	88.30	-33.13	1.44 V	25	20.21	34.96
2	4480.00	47.25 AV	68.30	-21.05	1.44 V	25	12.29	34.96
3	*5600.00	105.80 PK			1.05 V	100	68.90	36.90
4	*5600.00	94.50 AV			1.05 V	100	57.60	36.90
5	#11200.00	56.30 PK	74.00	-17.70	1.56 V	98	9.50	46.80
6	#11200.00	42.80 AV	54.00	-11.20	1.56 V	98	-4.00	46.80

- NOTE:**
1. Emission level(dBuV/m)=Raw Value(dBuV) + Correction Factor(dB/m)
  2. Correction Factor(dB/m) = Antenna Factor (dB/m) + Cable Factor (dB)
  3. The other emission levels were very low against the limit.
  4. Margin value = Emission level – Limit value
  5. "\*" : Fundamental frequency
  6. "#"The radiated frequency falling in the restricted band.

EUT TEST CONDITION		MEASUREMENT DETAIL	
CHANNEL	Channel 19	FREQUENCY RANGE	1 ~ 40 GHz
INPUT POWER (SYSTEM)	120Vac, 60 Hz	DETECTOR FUNCTION	Peak(PK) Average (AV)
ENVIRONMENTAL CONDITIONS	19 deg. C, 70%RH, 972hPa	TESTED BY	Phoenix Huang

ANTENNA POLARITY & TEST DISTANCE: HORIZONTAL AT 3 M								
No.	Freq. (MHz)	Emission Level (dBuV/m)	Limit (dBuV/m)	Margin (dB)	Antenna Height (m)	Table Angle (Degree)	Raw Value (dBuV)	Correction Factor (dB/m)
1	#4560.00	59.30 PK	74.00	-14.70	1.23 H	357	24.16	35.14
2	#4560.00	52.00 AV	54.00	-2.00	1.23 H	357	16.86	35.14
3	*5700.00	99.72 PK			1.18 H	121	62.57	37.15
4	*5700.00	89.24 AV			1.18 H	121	52.09	37.15
5	#9120.00	56.90 PK	74.00	-17.10	1.26 H	240	12.16	44.74
6	#9120.00	53.50 AV	54.00	-0.50	1.26 H	240	8.76	44.74
7	#11400.00	58.10 PK	74.00	-15.90	1.18 H	328	11.15	46.95
8	#11400.00	44.60 AV	54.00	-9.40	1.18 H	328	-2.35	46.95

ANTENNA POLARITY & TEST DISTANCE: VERTICAL AT 3 M								
No.	Freq. (MHz)	Emission Level (dBuV/m)	Limit (dBuV/m)	Margin (dB)	Antenna Height (m)	Table Angle (Degree)	Raw Value (dBuV)	Correction Factor (dB/m)
1	#4560.00	58.73 PK	74.00	-15.27	1.46 V	29	23.59	35.14
2	#4560.00	51.47 AV	54.00	-2.53	1.46 V	29	16.33	35.14
3	*5700.00	106.80 PK			1.02 V	73	69.65	37.15
4	*5700.00	94.30 AV			1.02 V	73	57.15	37.15
5	#9120.00	57.18 PK	74.00	-16.82	1.59 V	316	12.44	44.74
6	#9120.00	50.69 AV	54.00	-3.31	1.59 V	316	5.95	44.74
7	#11400.00	58.17 PK	74.00	-15.83	1.60 V	33	11.22	46.95
8	#11400.00	43.84 AV	54.00	-10.16	1.60 V	33	-3.11	46.95

- NOTE:**
1. Emission level(dBuV/m)=Raw Value(dBuV) + Correction Factor(dB/m)
  2. Correction Factor(dB/m) = Antenna Factor (dB/m) + Cable Factor (dB)
  3. The other emission levels were very low against the limit.
  4. Margin value = Emission level – Limit value
  5. "\*" : Fundamental frequency
  6. "#"The radiated frequency falling in the restricted band.

RESTRICTED BANDEDGE (DRAFT 802.11n (20MHz) MODE, CH1, HORIZONTAL )

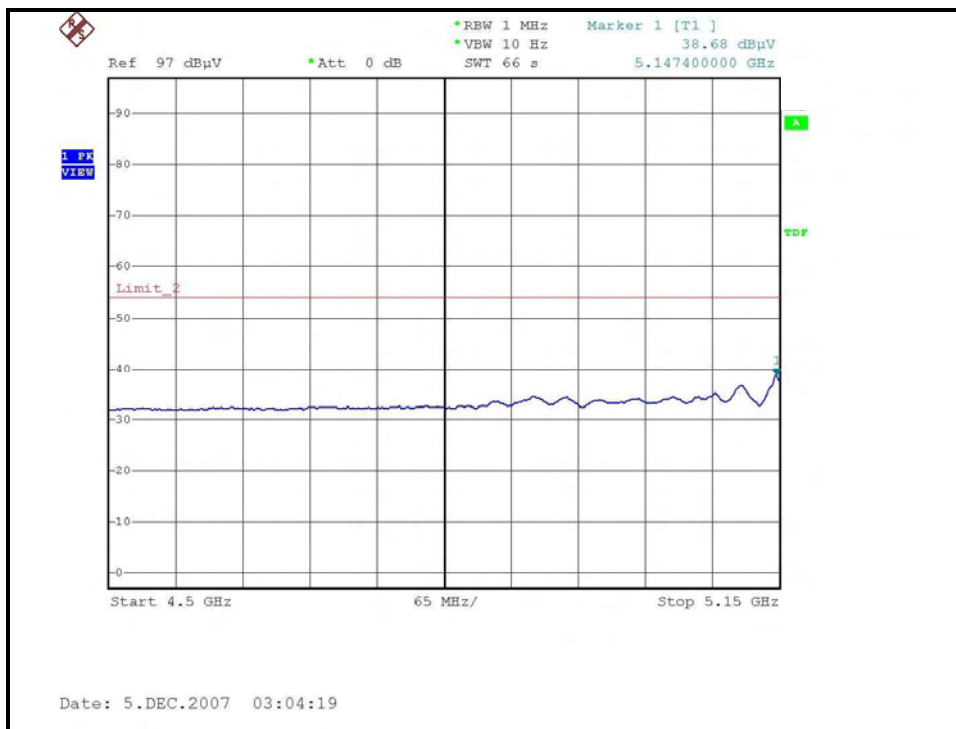
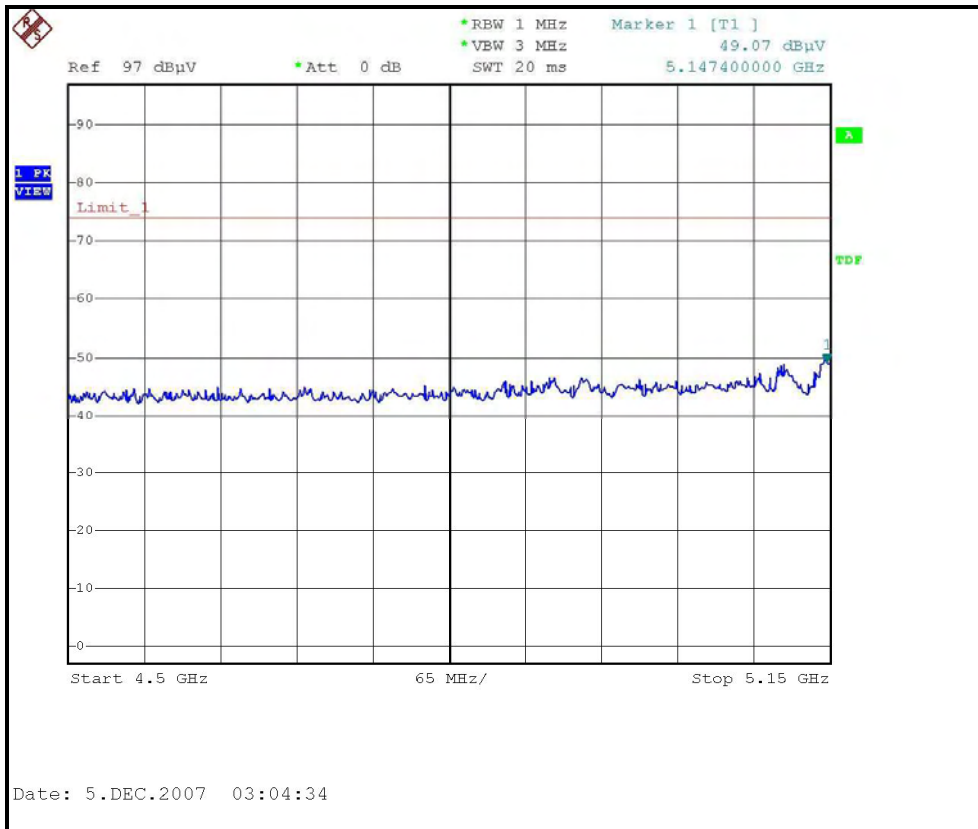

RESTRICTED BANDEDGE (DRAFT 802.11n (20MHz) MODE, CH1, VERTICAL )

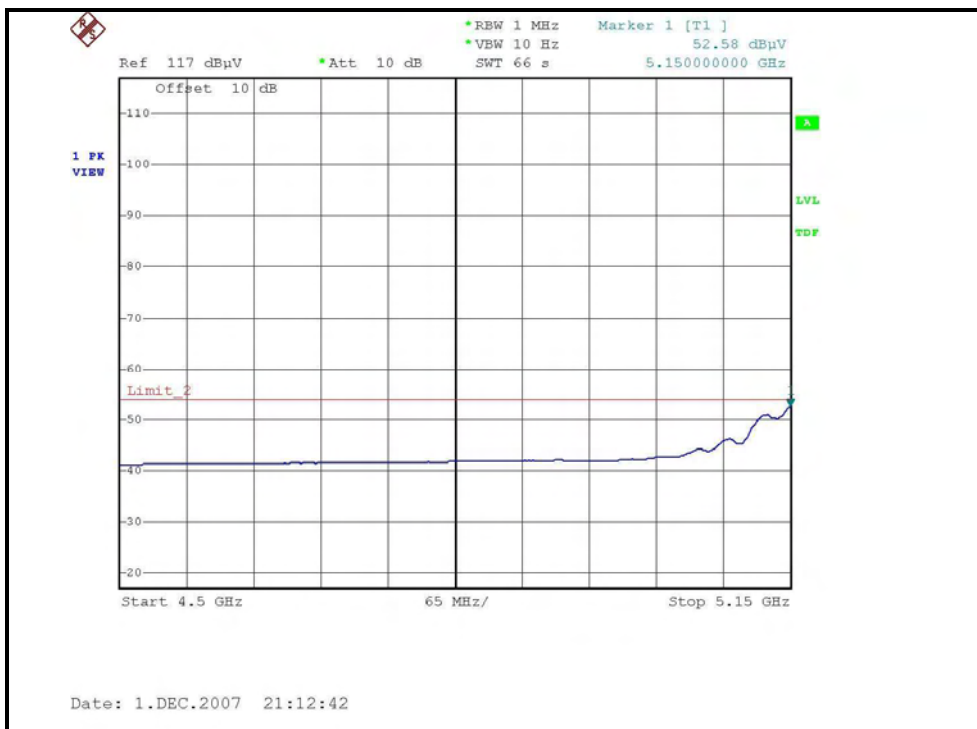
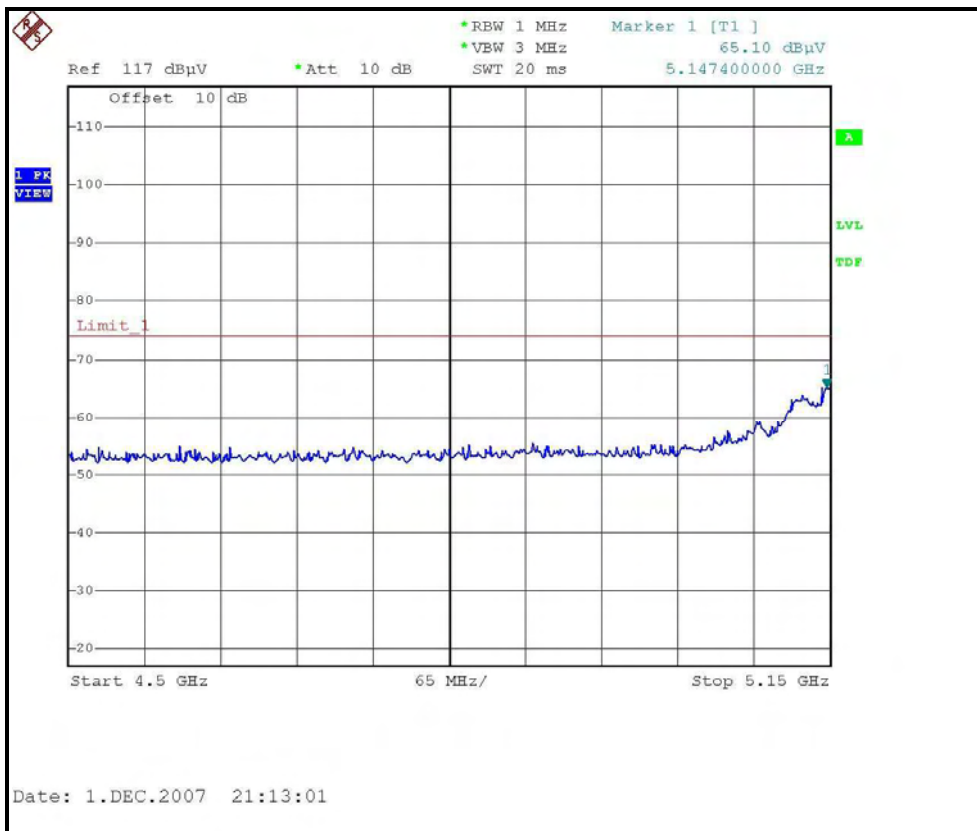



RESTRICTED BANDEDGE (DRAFT 802.11n (20MHz) MODE, CH8, HORIZONTAL )

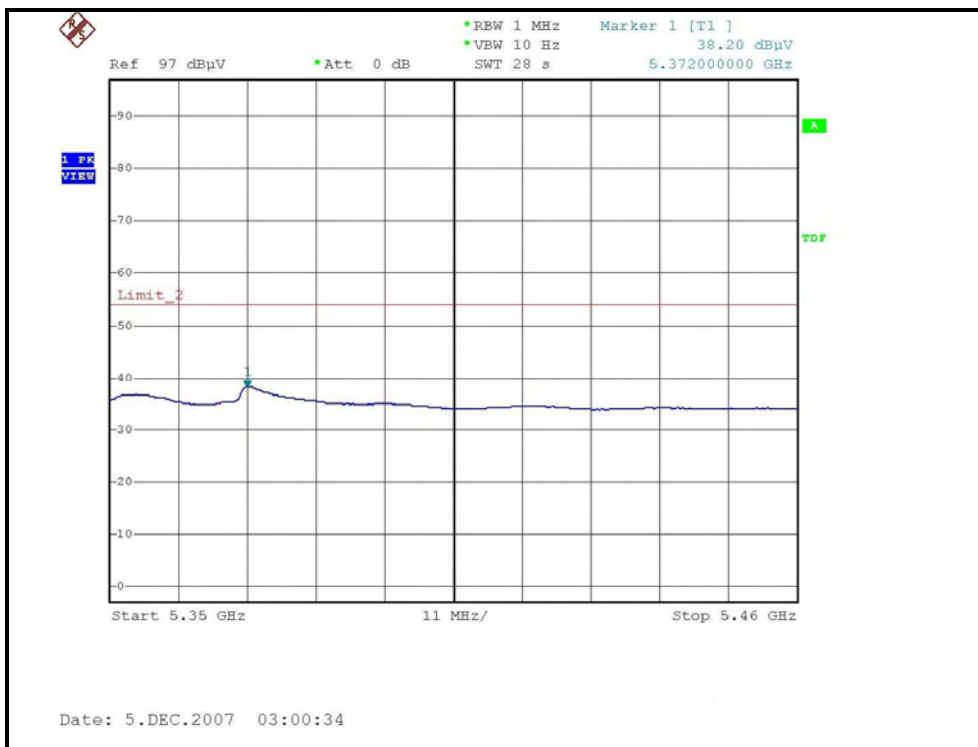
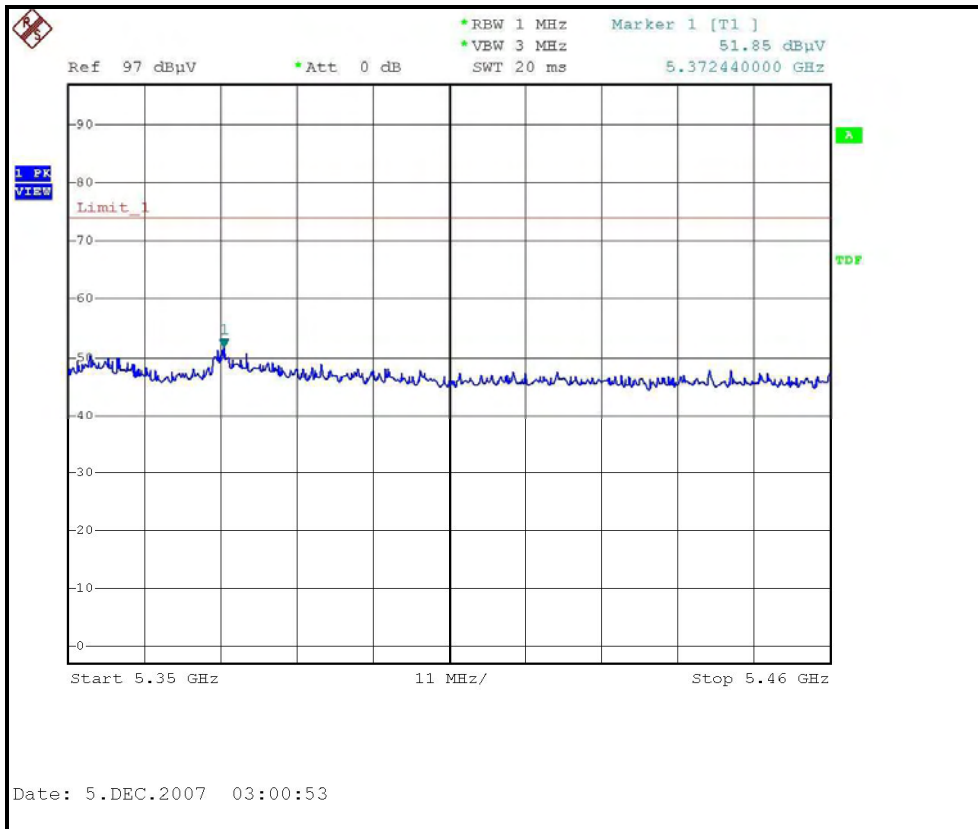

RESTRICTED BANDEDGE (DRAFT 802.11n (20MHz) MODE,CH8, VERTICAL )

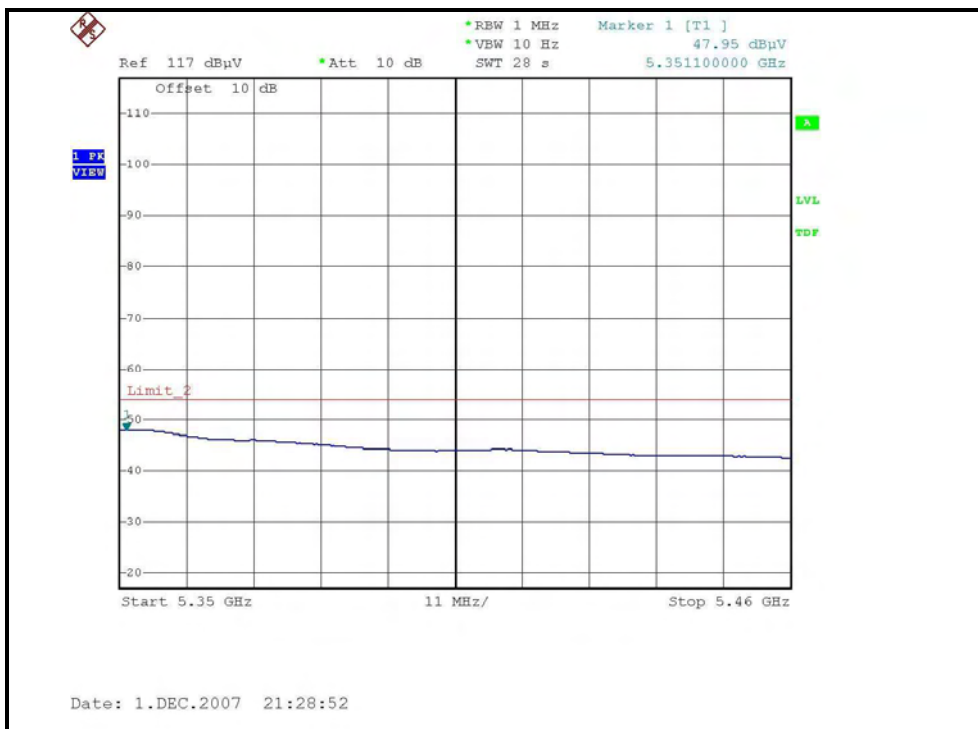
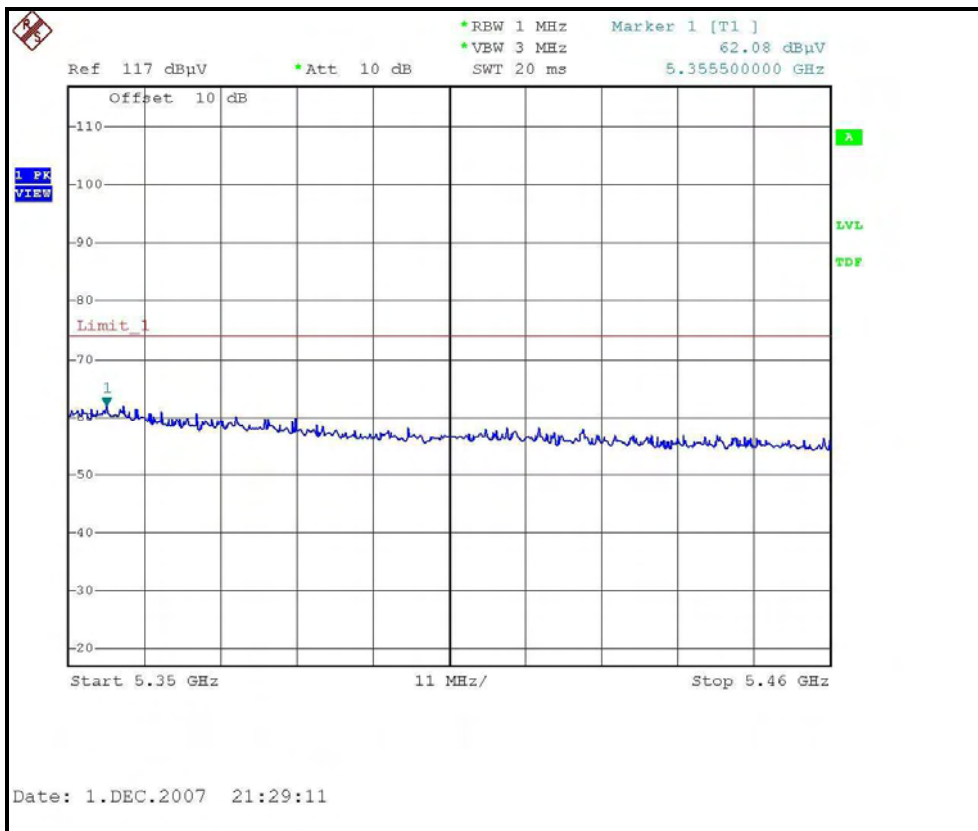

RESTRICTED BANDEDGE (DRAFT 802.11n (20MHz) MODE, CH9, HORIZONTAL )

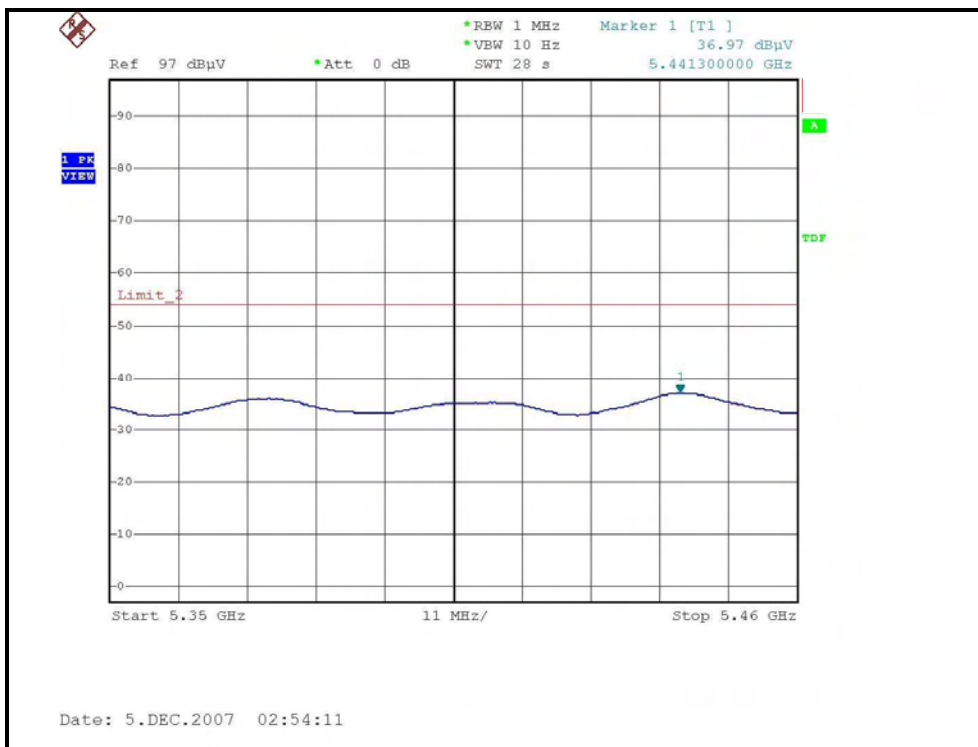
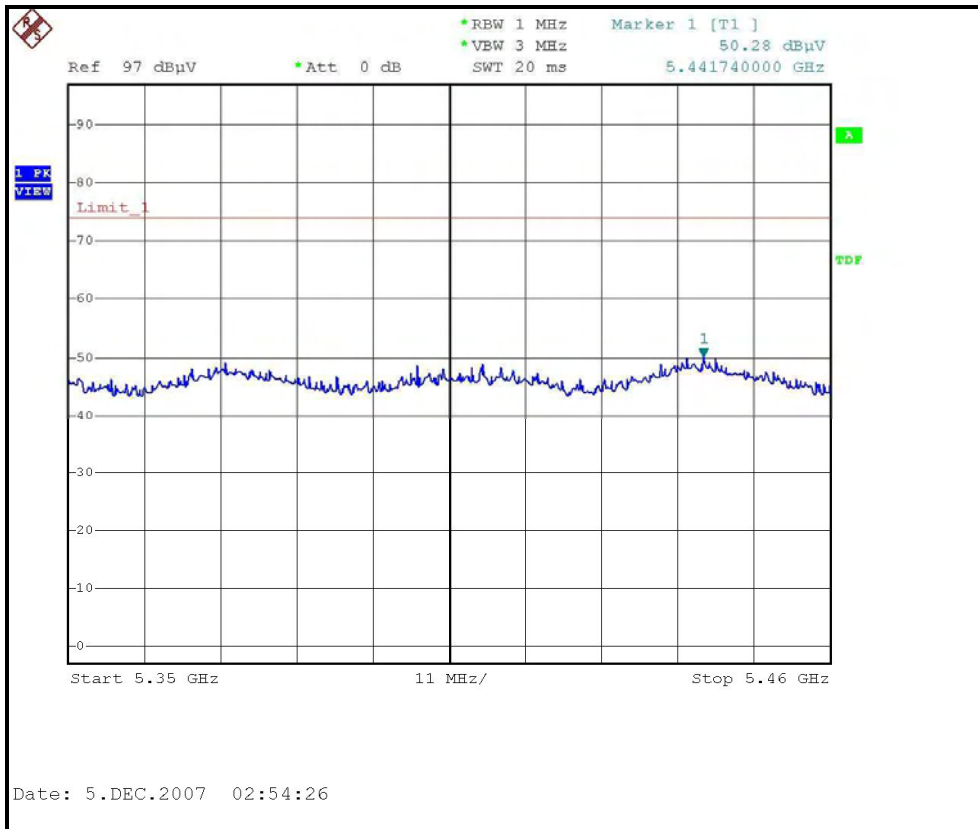

RESTRICTED BANDEDGE (DRAFT 802.11n (20MHz) MODE, CH9, VERTICAL )

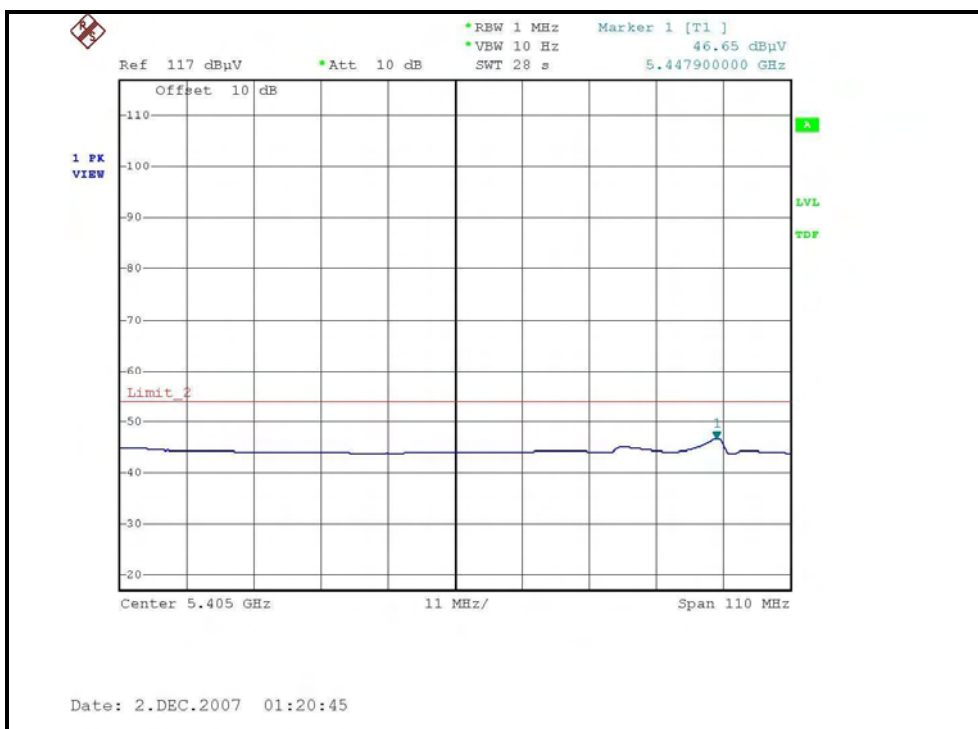
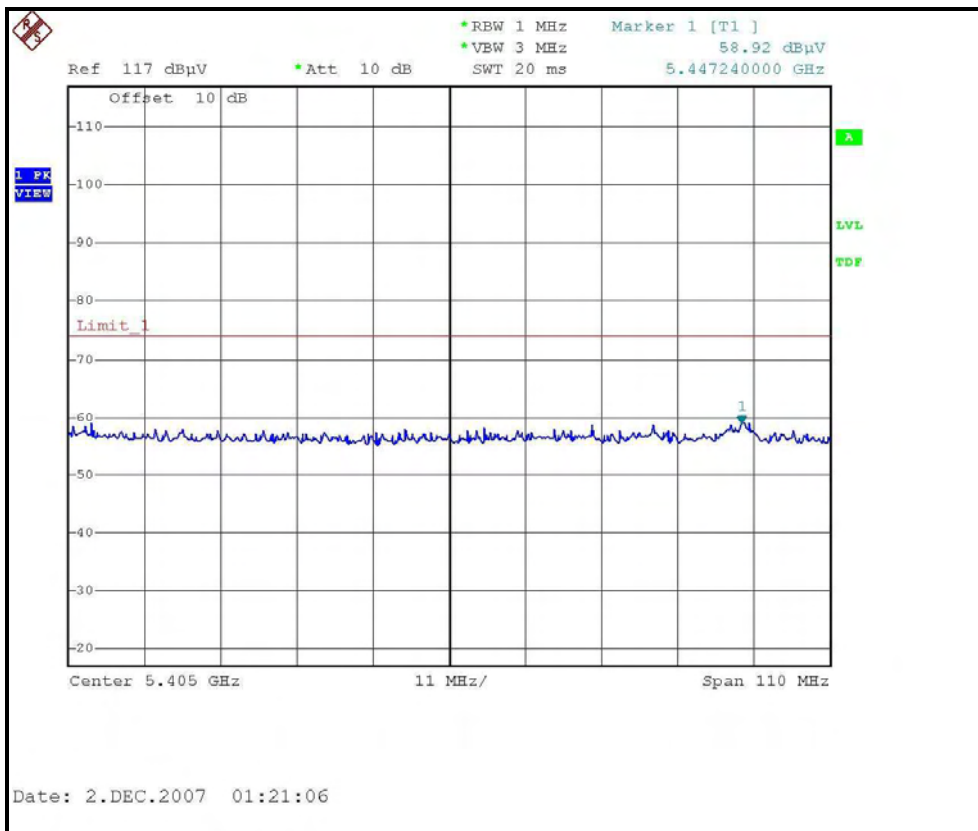

**DRAFT 802.11n (40MHz) OFDM MODULATION:**

EUT TEST CONDITION		MEASUREMENT DETAIL	
CHANNEL	Channel 1	FREQUENCY RANGE	1 ~ 40 GHz
INPUT POWER (SYSTEM)	120Vac, 60 Hz	DETECTOR FUNCTION	Peak(PK) Average (AV)
ENVIRONMENTAL CONDITIONS	19 deg. C, 70%RH, 972hPa	TESTED BY	Phoenix Huang

ANTENNA POLARITY & TEST DISTANCE: HORIZONTAL AT 3 M								
No.	Freq. (MHz)	Emission Level (dBuV/m)	Limit (dBuV/m)	Margin (dB)	Antenna Height (m)	Table Angle (Degree)	Raw Value (dBuV)	Correction Factor (dB/m)
1	#4152.00	54.50 PK	74.00	-19.50	1.26 H	204	20.52	33.98
2	#4152.00	46.50 AV	54.00	-7.50	1.26 H	204	12.52	33.98
3	#5150.00	56.31 PK	74.00	-17.69	1.26 H	191	20.07	36.24
4	#5150.00	40.22 AV	54.00	-13.78	1.26 H	191	3.98	36.24
5	*5190.00	102.70 PK			1.33 H	260	66.41	36.29
6	*5190.00	91.63 AV			1.33 H	260	55.34	36.29
7	#8304.00	56.90 PK	74.00	-17.10	1.29 H	59	12.69	44.21
8	#8304.00	49.50 AV	54.00	-4.50	1.29 H	59	5.29	44.21
9	10380.00	57.30 PK	88.30	-31.00	1.30 H	179	11.37	45.93
10	10380.00	44.70 AV	68.30	-23.60	1.30 H	179	-1.23	45.93

ANTENNA POLARITY & TEST DISTANCE: VERTICAL AT 3 M								
No.	Freq. (MHz)	Emission Level (dBuV/m)	Limit (dBuV/m)	Margin (dB)	Antenna Height (m)	Table Angle (Degree)	Raw Value (dBuV)	Correction Factor (dB/m)
1	#4152.00	54.60 PK	74.00	-19.40	1.29 V	58	20.62	33.98
2	#4152.00	47.18 AV	54.00	-6.82	1.29 V	58	13.20	33.98
3	#5150.00	65.56 PK	74.00	-8.44	1.14 V	334	29.32	36.24
4	#5150.00	52.80 AV	54.00	-1.20	1.14 V	334	16.56	36.24
5	*5190.00	104.50 PK			1.13 V	23	68.21	36.29
6	*5190.00	94.90 AV			1.13 V	23	58.61	36.29
7	#8304.00	55.42 PK	74.00	-18.58	1.58 V	64	11.21	44.21
8	#8304.00	48.65 AV	54.00	-5.35	1.58 V	64	4.44	44.21
9	10380.00	56.29 PK	88.30	-32.01	1.32 V	160	10.36	45.93
10	10380.00	43.17 AV	68.30	-25.13	1.32 V	160	-2.76	45.93

- NOTE:**
1. Emission level(dBuV/m)=Raw Value(dBuV) + Correction Factor(dB/m)
  2. Correction Factor(dB/m) = Antenna Factor (dB/m) + Cable Factor (dB)
  3. The other emission levels were very low against the limit.
  4. Margin value = Emission level – Limit value
  5. "\*" : Fundamental frequency
  6. "#"The radiated frequency falling in the restricted band.

EUT TEST CONDITION		MEASUREMENT DETAIL	
CHANNEL	Channel 2	FREQUENCY RANGE	1 ~ 40 GHz
INPUT POWER (SYSTEM)	120Vac, 60 Hz	DETECTOR FUNCTION	Peak(PK) Average (AV)
ENVIRONMENTAL CONDITIONS	19 deg. C, 70%RH, 972hPa	TESTED BY	Phoenix Huang

ANTENNA POLARITY & TEST DISTANCE: HORIZONTAL AT 3 M								
No.	Freq. (MHz)	Emission Level (dBuV/m)	Limit (dBuV/m)	Margin (dB)	Antenna Height (m)	Table Angle (Degree)	Raw Value (dBuV)	Correction Factor (dB/m)
1	#4184.00	55.90 PK	74.00	-18.10	1.45 H	240	21.83	34.07
2	#4184.00	48.70 AV	54.00	-5.30	1.45 H	240	14.63	34.07
3	*5230.00	98.24 PK			1.29 H	30	61.90	36.34
4	*5230.00	88.16 AV			1.29 H	30	51.82	36.34
5	#8368.00	56.90 PK	74.00	-17.10	1.18 H	62	12.72	44.18
6	#8368.00	50.80 AV	54.00	-3.20	1.18 H	62	6.62	44.18
7	10460.00	58.30 PK	88.30	-30.00	1.40 H	270	12.22	46.08
8	10460.00	45.20 AV	68.30	-23.10	1.40 H	270	-0.88	46.08

ANTENNA POLARITY & TEST DISTANCE: VERTICAL AT 3 M								
No.	Freq. (MHz)	Emission Level (dBuV/m)	Limit (dBuV/m)	Margin (dB)	Antenna Height (m)	Table Angle (Degree)	Raw Value (dBuV)	Correction Factor (dB/m)
1	#4184.00	54.27 PK	74.00	-19.73	1.32 V	269	20.20	34.07
2	#4184.00	46.13 AV	54.00	-7.87	1.32 V	269	12.06	34.07
3	*5230.00	104.30 PK			1.23 V	106	67.96	36.34
4	*5230.00	92.70 AV			1.23 V	106	56.36	36.34
5	#8368.00	57.14 PK	74.00	-16.86	1.56 V	37	12.96	44.18
6	#8368.00	49.88 AV	54.00	-4.12	1.56 V	37	5.70	44.18
7	10460.00	58.63 PK	88.30	-29.67	1.49 V	26	12.55	46.08
8	10460.00	44.31 AV	68.30	-23.99	1.49 V	26	-1.77	46.08

- NOTE:**
1. Emission level(dBuV/m)=Raw Value(dBuV) + Correction Factor(dB/m)
  2. Correction Factor(dB/m) = Antenna Factor (dB/m) + Cable Factor (dB)
  3. The other emission levels were very low against the limit.
  4. Margin value = Emission level – Limit value
  5. “\*” : Fundamental frequency
  6. “#”The radiated frequency falling in the restricted band.

EUT TEST CONDITION		MEASUREMENT DETAIL	
CHANNEL	Channel 3	FREQUENCY RANGE	1 ~ 40 GHz
INPUT POWER (SYSTEM)	120Vac, 60 Hz	DETECTOR FUNCTION	Peak(PK) Average (AV)
ENVIRONMENTAL CONDITIONS	19 deg. C, 70%RH, 972hPa	TESTED BY	Phoenix Huang

ANTENNA POLARITY & TEST DISTANCE: HORIZONTAL AT 3 M								
No.	Freq. (MHz)	Emission Level (dBuV/m)	Limit (dBuV/m)	Margin (dB)	Antenna Height (m)	Table Angle (Degree)	Raw Value (dBuV)	Correction Factor (dB/m)
1	#4216.00	56.90 PK	74.00	-17.10	1.45 H	243	22.73	34.17
2	#4216.00	49.90 AV	54.00	-4.10	1.45 H	243	15.73	34.17
3	*5270.00	98.47 PK			1.52 H	21	62.09	36.38
4	*5270.00	88.73 AV			1.52 H	21	52.35	36.38
5	#8432.00	57.70 PK	74.00	-16.30	1.18 H	108	13.55	44.15
6	#8432.00	50.60 AV	54.00	-3.40	1.18 H	108	6.45	44.15
7	10540.00	57.80 PK	88.30	-30.50	1.19 H	232	11.61	46.19
8	10540.00	45.00 AV	68.30	-23.30	1.19 H	232	-1.19	46.19

ANTENNA POLARITY & TEST DISTANCE: VERTICAL AT 3 M								
No.	Freq. (MHz)	Emission Level (dBuV/m)	Limit (dBuV/m)	Margin (dB)	Antenna Height (m)	Table Angle (Degree)	Raw Value (dBuV)	Correction Factor (dB/m)
1	#4216.00	54.37 PK	74.00	-19.63	1.64 V	29	20.20	34.17
2	#4216.00	48.14 AV	54.00	-5.86	1.64 V	29	13.97	34.17
3	*5270.00	103.60 PK			1.24 V	68	67.22	36.38
4	*5270.00	93.80 AV			1.24 V	68	57.42	36.38
5	#8432.00	57.22 PK	74.00	-16.78	1.50 V	30	13.07	44.15
6	#8432.00	49.69 AV	54.00	-4.31	1.50 V	30	5.54	44.15
7	10540.00	58.62 PK	88.30	-29.68	1.43 V	291	12.43	46.19
8	10540.00	44.81 AV	68.30	-23.49	1.43 V	291	-1.38	46.19

- NOTE:**
1. Emission level(dBuV/m)=Raw Value(dBuV) + Correction Factor(dB/m)
  2. Correction Factor(dB/m) = Antenna Factor (dB/m) + Cable Factor (dB)
  3. The other emission levels were very low against the limit.
  4. Margin value = Emission level – Limit value
  5. "\*" : Fundamental frequency
  6. "#"The radiated frequency falling in the restricted band.

EUT TEST CONDITION		MEASUREMENT DETAIL	
CHANNEL	Channel 4	FREQUENCY RANGE	1 ~ 40 GHz
INPUT POWER (SYSTEM)	120Vac, 60 Hz	DETECTOR FUNCTION	Peak(PK) Average (AV)
ENVIRONMENTAL CONDITIONS	19 deg. C, 70%RH, 972hPa	TESTED BY	Phoenix Huang

ANTENNA POLARITY & TEST DISTANCE: HORIZONTAL AT 3 M								
No.	Freq. (MHz)	Emission Level (dBuV/m)	Limit (dBuV/m)	Margin (dB)	Antenna Height (m)	Table Angle (Degree)	Raw Value (dBuV)	Correction Factor (dB/m)
1	#4248.00	58.00 PK	74.00	-16.00	1.58 H	230	23.74	34.26
2	#4248.00	49.30 AV	54.00	-4.70	1.58 H	230	15.04	34.26
3	*5310.00	100.21 PK			1.40 H	0	63.78	36.43
4	*5310.00	89.76 AV			1.40 H	0	53.33	36.43
5	#5358.00	55.01 PK	74.00	-18.99	1.37 H	0	18.52	36.49
6	#5358.00	41.70 AV	54.00	-12.30	1.37 H	0	5.21	36.49
7	#8496.00	58.20 PK	74.00	-15.80	1.16 H	56	14.09	44.11
8	#8496.00	51.80 AV	54.00	-2.20	1.16 H	56	7.69	44.11
9	#10620.00	56.70 PK	74.00	-17.30	1.62 H	148	10.43	46.27
10	#10620.00	44.30 AV	54.00	-9.70	1.62 H	148	-1.97	46.27

ANTENNA POLARITY & TEST DISTANCE: VERTICAL AT 3 M								
No.	Freq. (MHz)	Emission Level (dBuV/m)	Limit (dBuV/m)	Margin (dB)	Antenna Height (m)	Table Angle (Degree)	Raw Value (dBuV)	Correction Factor (dB/m)
1	#4248.00	53.86 PK	74.00	-20.14	1.64 V	288	19.60	34.26
2	#4248.00	47.24 AV	54.00	-6.76	1.64 V	288	12.98	34.26
3	*5310.00	104.10 PK			1.12 V	26	67.67	36.43
4	*5310.00	93.00 AV			1.12 V	26	56.57	36.43
5	#5358.00	60.60 PK	74.00	-13.40	1.00 V	33	24.12	36.48
6	#5358.00	47.70 AV	54.00	-6.30	1.00 V	33	11.22	36.48
7	#8496.00	56.82 PK	74.00	-17.18	1.57 V	43	12.71	44.11
8	#8496.00	50.49 AV	54.00	-3.51	1.57 V	43	6.38	44.11
9	#10620.00	57.69 PK	74.00	-16.31	1.47 V	83	11.42	46.27
10	#10620.00	43.22 AV	54.00	-10.78	1.47 V	83	-3.05	46.27

- NOTE:**
1. Emission level(dBuV/m)=Raw Value(dBuV) + Correction Factor(dB/m)
  2. Correction Factor(dB/m) = Antenna Factor (dB/m) + Cable Factor (dB)
  3. The other emission levels were very low against the limit.
  4. Margin value = Emission level – Limit value
  5. "\*" : Fundamental frequency
  6. "#"The radiated frequency falling in the restricted band.



EUT TEST CONDITION		MEASUREMENT DETAIL	
CHANNEL	Channel 5	FREQUENCY RANGE	1 ~ 40 GHz
INPUT POWER (SYSTEM)	120Vac, 60 Hz	DETECTOR FUNCTION	Peak(PK) Average (AV)
ENVIRONMENTAL CONDITIONS	19 deg. C, 70%RH, 972hPa	TESTED BY	Phoenix Huang

ANTENNA POLARITY & TEST DISTANCE: HORIZONTAL AT 3 M								
No.	Freq. (MHz)	Emission Level (dBuV/m)	Limit (dBuV/m)	Margin (dB)	Antenna Height (m)	Table Angle (Degree)	Raw Value (dBuV)	Correction Factor (dB/m)
1	4408.00	55.90 PK	88.30	-32.40	1.33 H	21	21.16	34.74
2	4408.00	45.90 AV	68.30	-22.40	1.33 H	21	11.16	34.74
3	#5379.00	56.06 PK	74.00	-17.94	1.21 H	0	19.55	36.51
4	#5379.00	41.70 AV	54.00	-12.30	1.21 H	0	5.19	36.51
5	*5510.00	100.72 PK			1.30 H	20	64.04	36.68
6	*5510.00	90.37 AV			1.30 H	20	53.69	36.68
7	#11020.00	56.20 PK	74.00	-17.80	1.33 H	311	9.53	46.67
8	#11020.00	44.20 AV	54.00	-9.80	1.33 H	311	-2.47	46.67

ANTENNA POLARITY & TEST DISTANCE: VERTICAL AT 3 M								
No.	Freq. (MHz)	Emission Level (dBuV/m)	Limit (dBuV/m)	Margin (dB)	Antenna Height (m)	Table Angle (Degree)	Raw Value (dBuV)	Correction Factor (dB/m)
1	4408.00	55.38 PK	88.30	-32.92	1.40 V	29	20.64	34.74
2	4408.00	45.21 AV	68.30	-23.09	1.40 V	29	10.47	34.74
3	#5379.00	58.90 PK	74.00	-15.10	1.29 V	112	22.29	36.61
4	#5379.00	44.60 AV	54.00	-9.40	1.29 V	112	7.99	36.61
5	*5510.00	102.60 PK			1.30 V	109	65.92	36.68
6	*5510.00	91.70 AV			1.30 V	109	55.02	36.68
7	#11020.00	56.84 PK	74.00	-17.16	1.30 V	64	10.17	46.67
8	#11020.00	43.22 AV	54.00	-10.78	1.30 V	64	-3.45	46.67

- NOTE:**
1. Emission level(dBuV/m)=Raw Value(dBuV) + Correction Factor(dB/m)
  2. Correction Factor(dB/m) = Antenna Factor (dB/m) + Cable Factor (dB)
  3. The other emission levels were very low against the limit.
  4. Margin value = Emission level – Limit value
  5. "\*" : Fundamental frequency
  6. "#"The radiated frequency falling in the restricted band.



EUT TEST CONDITION		MEASUREMENT DETAIL	
CHANNEL	Channel 7	FREQUENCY RANGE	1 ~ 40 GHz
INPUT POWER (SYSTEM)	120Vac, 60 Hz	DETECTOR FUNCTION	Peak(PK) Average (AV)
ENVIRONMENTAL CONDITIONS	19 deg. C, 70%RH, 972hPa	TESTED BY	Phoenix Huang

ANTENNA POLARITY & TEST DISTANCE: HORIZONTAL AT 3 M								
No.	Freq. (MHz)	Emission Level (dBuV/m)	Limit (dBuV/m)	Margin (dB)	Antenna Height (m)	Table Angle (Degree)	Raw Value (dBuV)	Correction Factor (dB/m)
1	4472.00	56.20 PK	88.30	-32.10	1.25 H	193	21.26	34.94
2	4472.00	47.20 AV	68.30	-21.10	1.25 H	193	12.26	34.94
3	*5590.00	97.65 PK			1.20 H	30	60.77	36.88
4	*5590.00	88.42 AV			1.20 H	30	51.54	36.88
5	#11180.00	56.30 PK	74.00	-17.70	1.19 H	147	9.51	46.79
6	#11180.00	45.30 AV	54.00	-8.70	1.19 H	147	-1.49	46.79

ANTENNA POLARITY & TEST DISTANCE: VERTICAL AT 3 M								
No.	Freq. (MHz)	Emission Level (dBuV/m)	Limit (dBuV/m)	Margin (dB)	Antenna Height (m)	Table Angle (Degree)	Raw Value (dBuV)	Correction Factor (dB/m)
1	4472.00	57.22 PK	88.30	-31.08	1.28 V	93	22.28	34.94
2	4472.00	49.69 AV	68.30	-18.61	1.28 V	93	14.75	34.94
3	*5590.00	103.40 PK			1.05 V	101	66.52	36.88
4	*5590.00	92.60 AV			1.05 V	101	55.72	36.88
5	#11180.00	56.89 PK	74.00	-17.11	1.20 V	115	10.10	46.79
6	#11180.00	44.11 AV	54.00	-9.89	1.20 V	115	-2.68	46.79

- NOTE:**
1. Emission level(dBuV/m)=Raw Value(dBuV) + Correction Factor(dB/m)
  2. Correction Factor(dB/m) = Antenna Factor (dB/m) + Cable Factor (dB)
  3. The other emission levels were very low against the limit.
  4. Margin value = Emission level – Limit value
  5. "\*" : Fundamental frequency
  6. "#"The radiated frequency falling in the restricted band.

EUT TEST CONDITION		MEASUREMENT DETAIL	
CHANNEL	Channel 9	FREQUENCY RANGE	1 ~ 40 GHz
INPUT POWER (SYSTEM)	120Vac, 60 Hz	DETECTOR FUNCTION	Peak(PK) Average (AV)
ENVIRONMENTAL CONDITIONS	19 deg. C, 70%RH, 972hPa	TESTED BY	Phoenix Huang

ANTENNA POLARITY & TEST DISTANCE: HORIZONTAL AT 3 M								
No.	Freq. (MHz)	Emission Level (dBuV/m)	Limit (dBuV/m)	Margin (dB)	Antenna Height (m)	Table Angle (Degree)	Raw Value (dBuV)	Correction Factor (dB/m)
1	#4536.00	57.40 PK	74.00	-16.60	1.42 H	4	22.31	35.09
2	#4536.00	49.10 AV	54.00	-4.90	1.42 H	4	14.01	35.09
3	*5670.00	102.00 PK			1.17 H	354	64.93	37.07
4	*5670.00	90.50 AV			1.17 H	354	53.43	37.07
5	9072.00	60.90 PK	74.00	-13.10	1.19 H	264	16.19	44.71
6	<b>9072.00</b>	<b>53.60 AV</b>	<b>54.00</b>	<b>-0.40</b>	<b>1.19 H</b>	<b>264</b>	<b>8.89</b>	<b>44.71</b>
7	#11340.00	59.30 PK	74.00	-14.70	1.19 H	330	12.39	46.91
8	#11340.00	45.20 AV	54.00	-8.80	1.19 H	330	-1.71	46.91

ANTENNA POLARITY & TEST DISTANCE: VERTICAL AT 3 M								
No.	Freq. (MHz)	Emission Level (dBuV/m)	Limit (dBuV/m)	Margin (dB)	Antenna Height (m)	Table Angle (Degree)	Raw Value (dBuV)	Correction Factor (dB/m)
1	#4536.00	57.42 PK	74.00	-16.58	1.27 V	22	22.33	35.09
2	#4536.00	50.62 AV	54.00	-3.38	1.27 V	22	15.53	35.09
3	*5670.00	104.00 PK			1.02 V	75	66.93	37.07
4	*5670.00	92.90 AV			1.02 V	75	55.83	37.07
5	9072.00	56.28 PK	74.00	-17.72	1.30 V	210	11.57	44.71
6	9072.00	49.24 AV	54.00	-4.76	1.30 V	210	4.53	44.71
7	#11340.00	57.83 PK	74.00	-16.17	1.50 V	230	11.00	46.83
8	#11340.00	44.72 AV	54.00	-9.28	1.50 V	230	-2.11	46.83

- NOTE:**
1. Emission level(dBuV/m)=Raw Value(dBuV) + Correction Factor(dB/m)
  2. Correction Factor(dB/m) = Antenna Factor (dB/m) + Cable Factor (dB)
  3. The other emission levels were very low against the limit.
  4. Margin value = Emission level – Limit value
  5. "\*" : Fundamental frequency
  6. "#"The radiated frequency falling in the restricted band.

RESTRICTED BANDEDGE (DRAFT 802.11n (40MHz) MODE, CH1, HORIZONTAL)

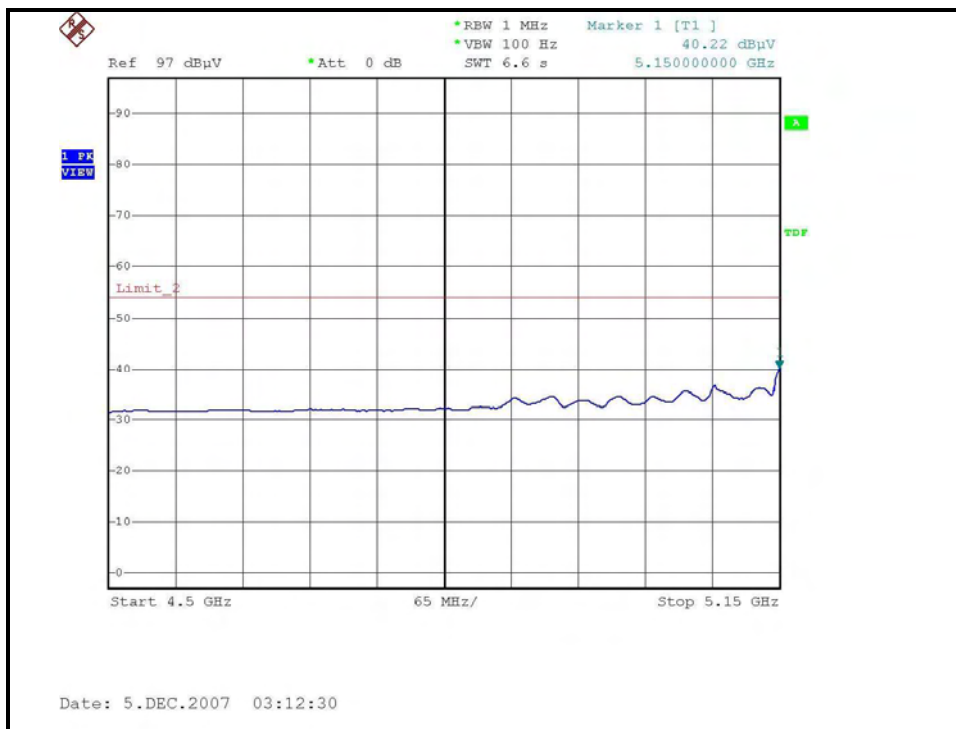
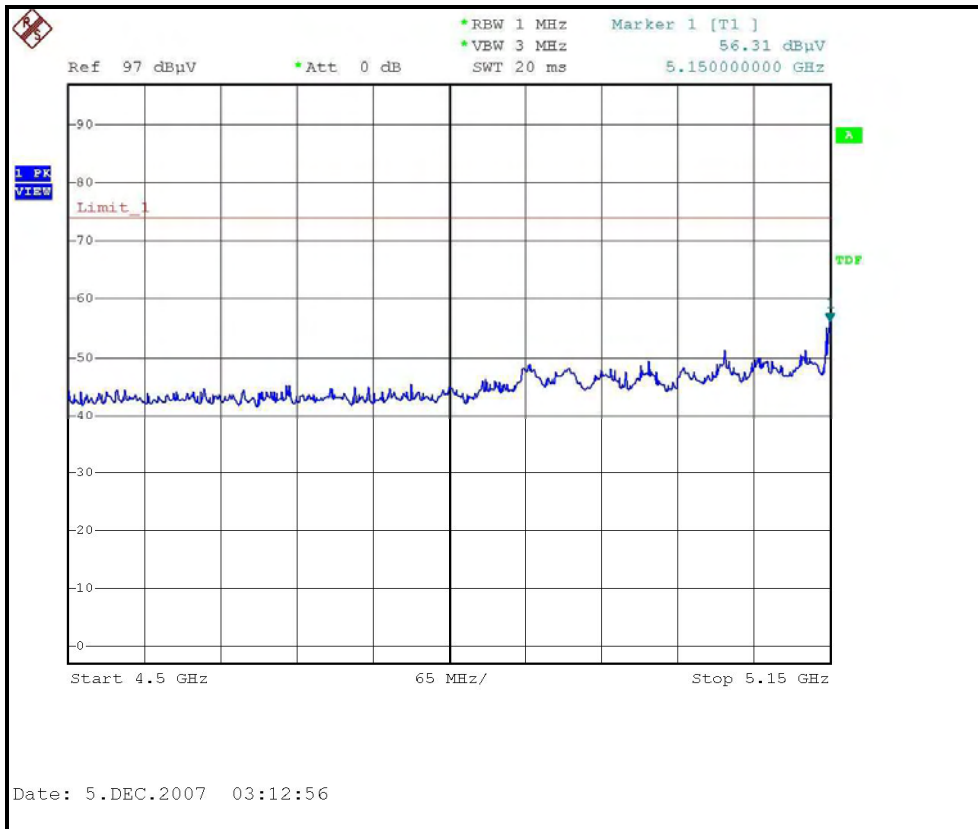

RESTRICTED BANDEDGE (DRAFT 802.11n (40MHz) MODE,CH1, VERTICAL )

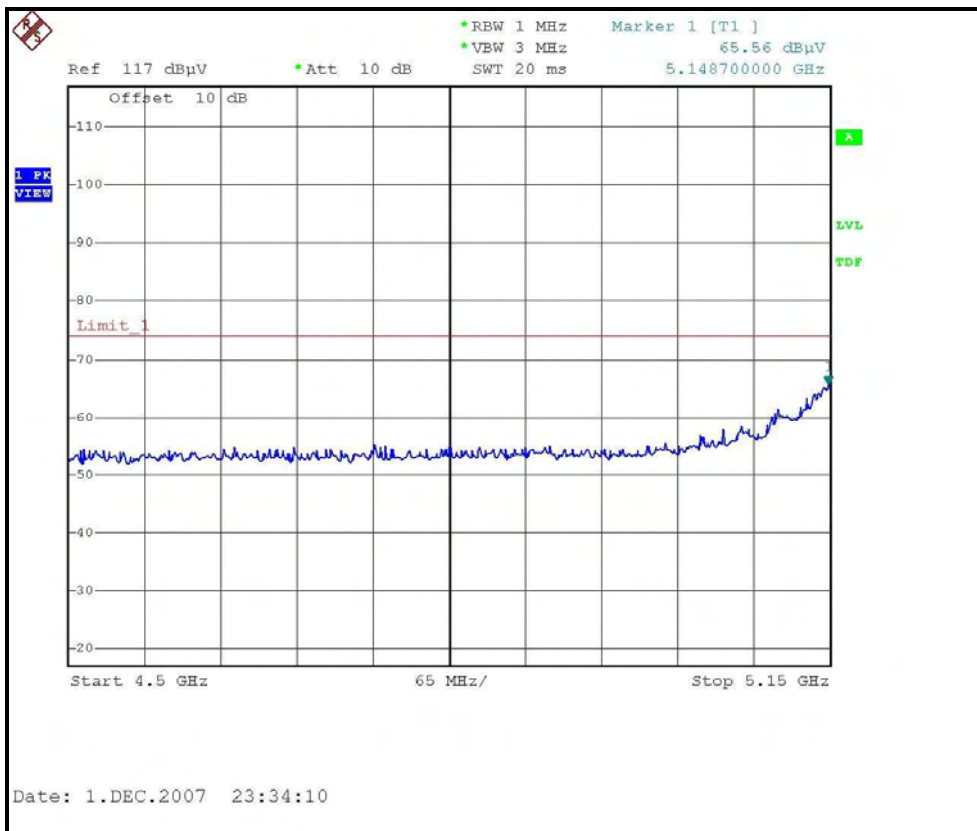

RESTRICTED BANDEDGE (DRAFT 802.11n (40MHz) MODE, CH4, HORIZONTAL)

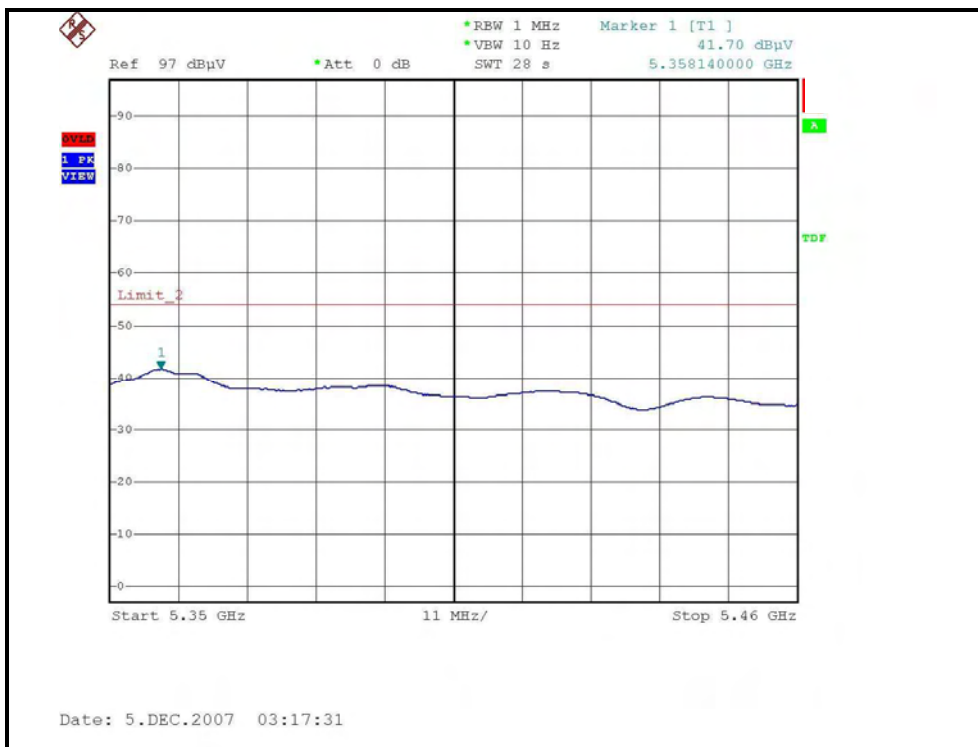
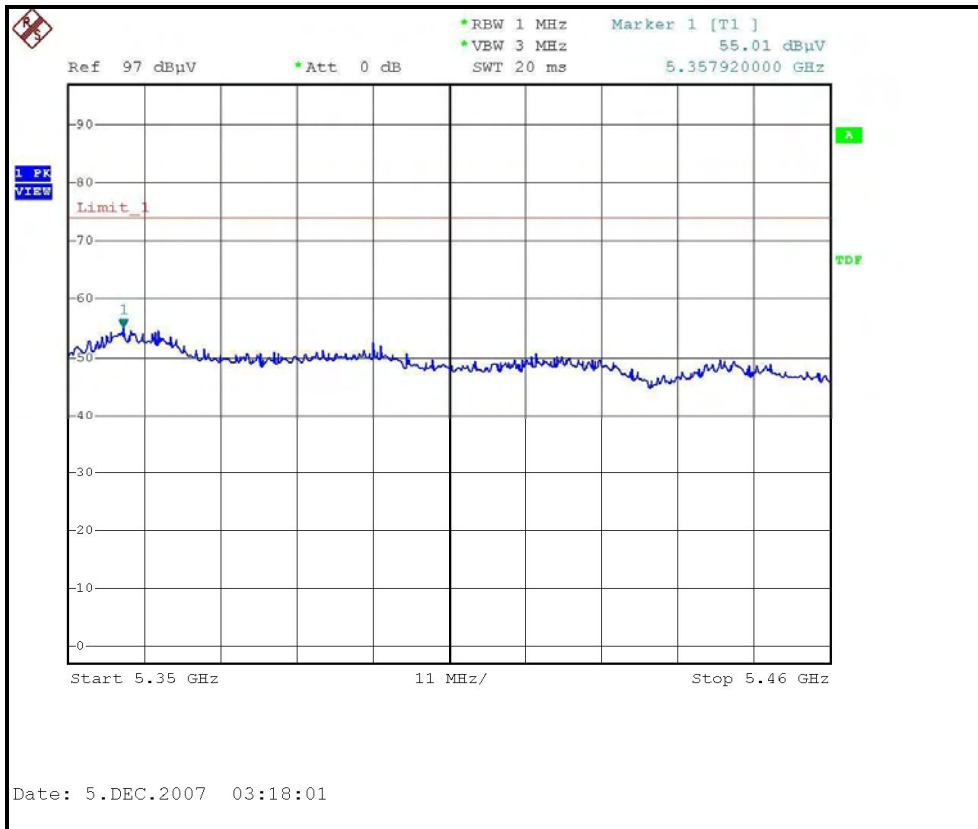

RESTRICTED BANDEDGE (DRAFT 802.11n (40MHz) MODE, CH4, VERTICAL)

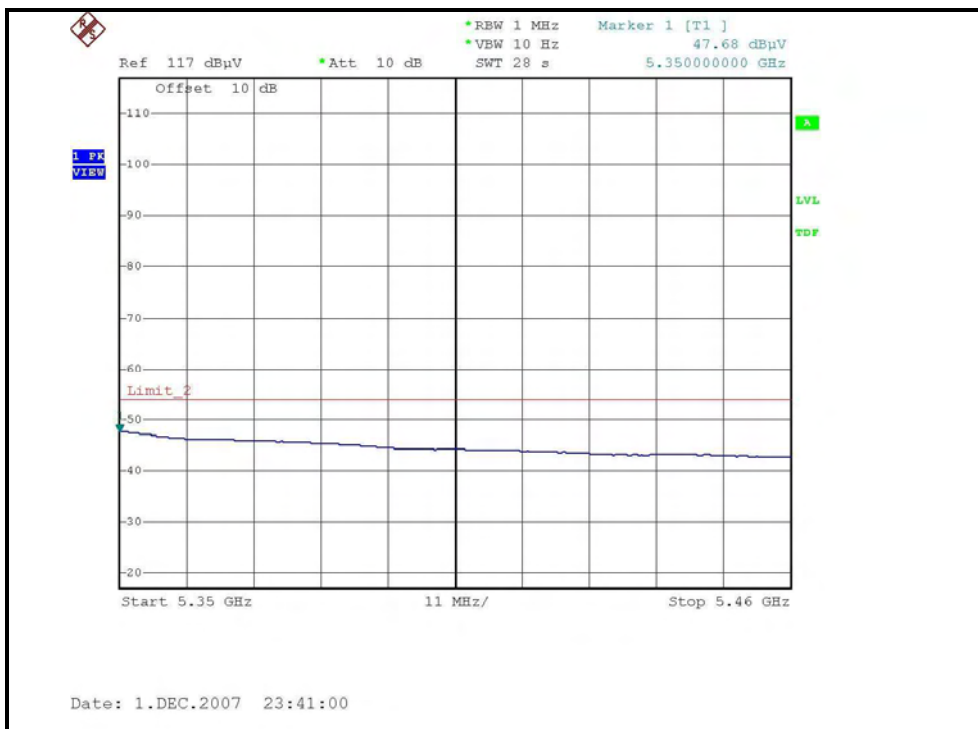
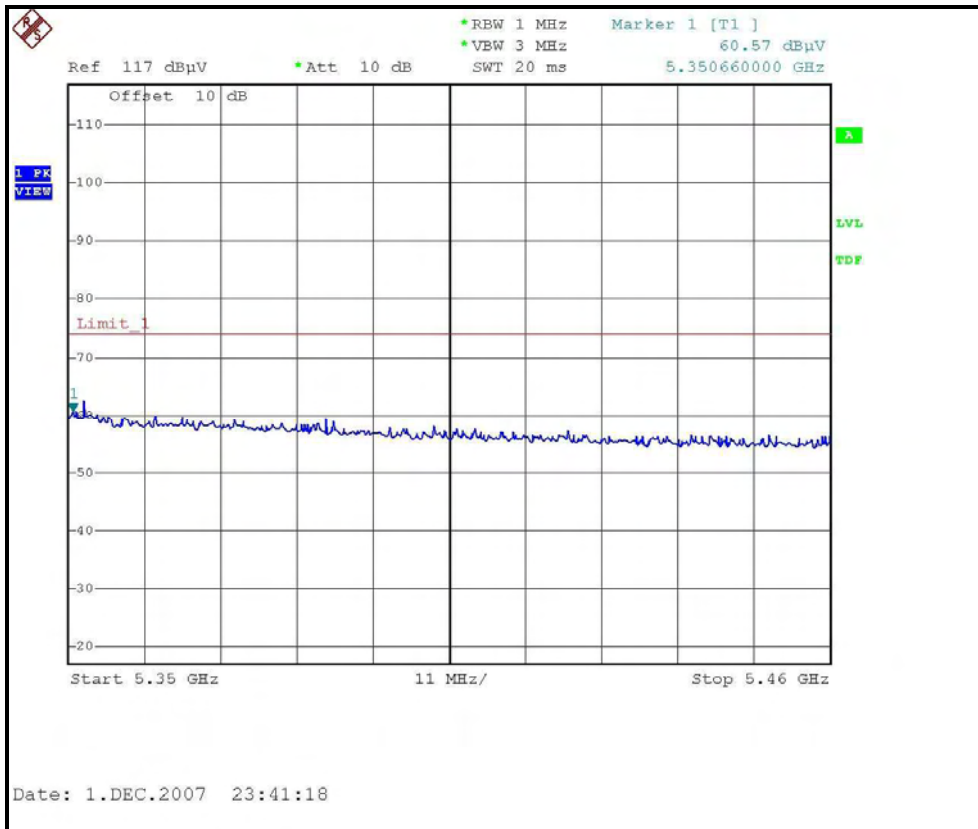

RESTRICTED BANDEDGE (DRAFT 802.11n (40MHz) MODE, CH5, HORIZONTAL)

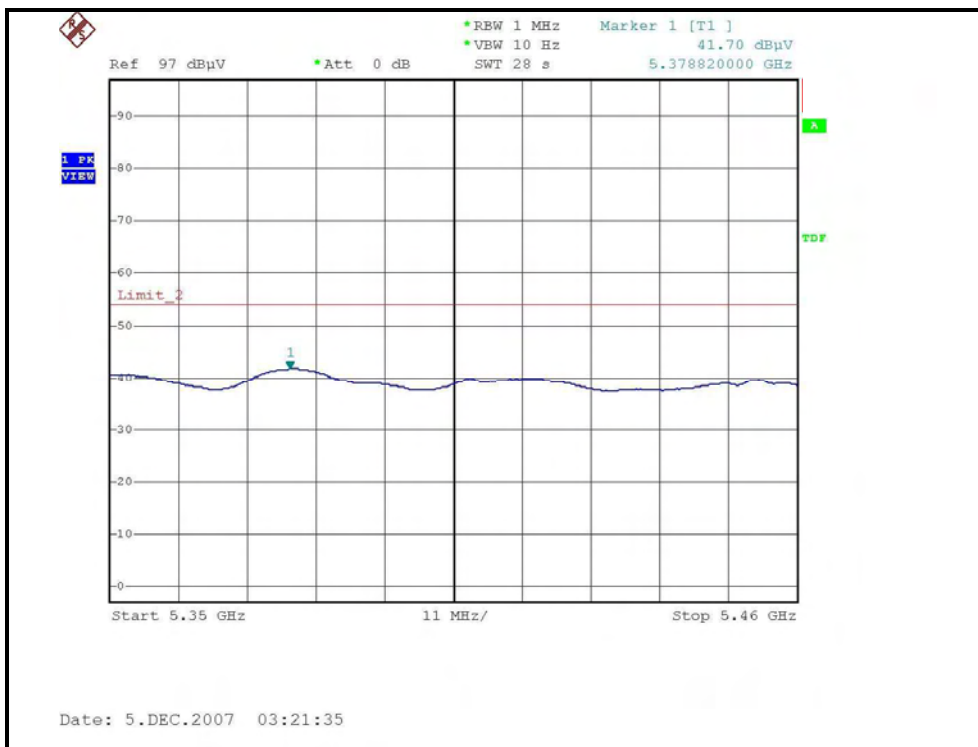
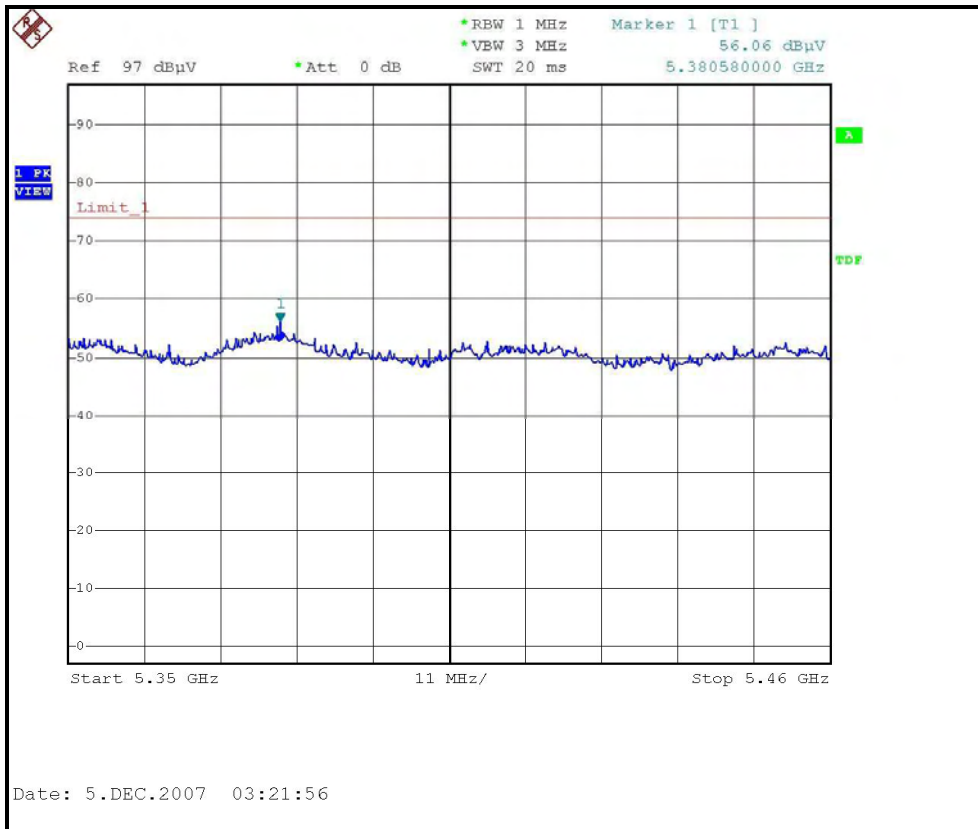



RESTRICTED BANDEDGE (DRAFT 802.11n (40MHz) MODE, CH5, VERTICAL)

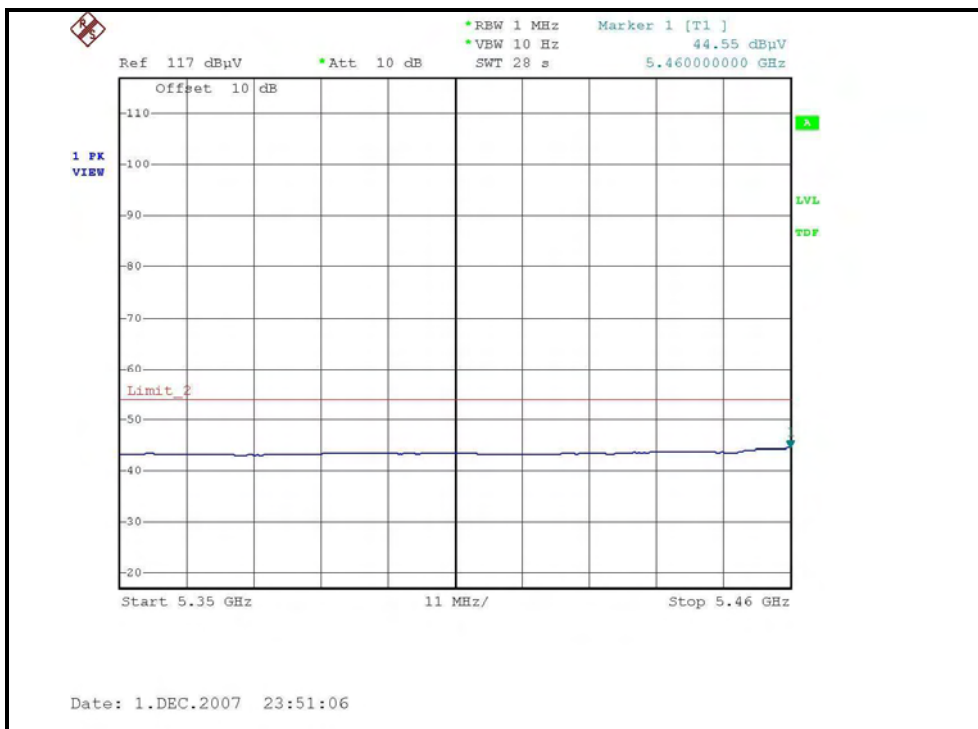
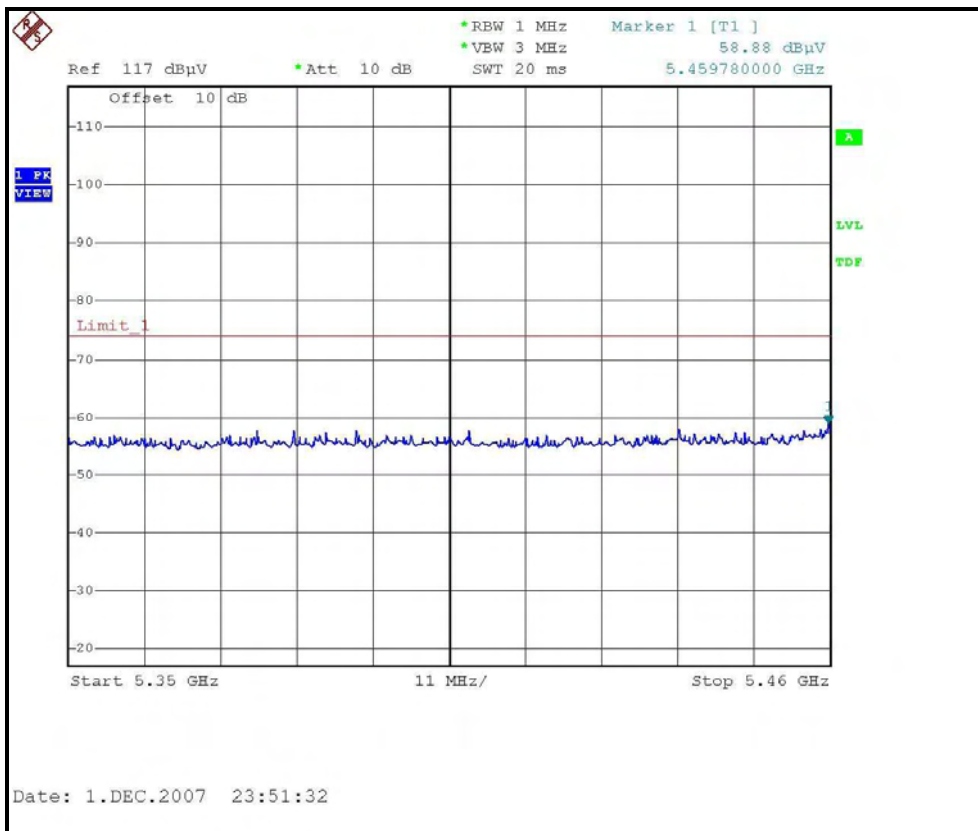



### 4.3 PEAK TRANSMIT POWER MEASUREMENT

#### 4.3.1 LIMITS OF PEAK TRANSMIT POWER MEASUREMENT

Frequency Band	Limit
5.15 – 5.25GHz	The lesser of 50mW (17dBm) or 4dBm + 10logB
5.25 – 5.35GHz	The lesser of 250mW (24dBm) or 11dBm + 10logB
5.47 – 5.725GHz	The lesser of 250mW (24dBm) or 11dBm + 10logB
5.725 – 5.825GHz	The lesser of 1W (30dBm) or 17dBm + 10logB

**NOTE:** Where B is the 26dB emission bandwidth in MHz.

#### 4.3.2 TEST INSTRUMENTS

Description & Manufacturer	Model No.	Serial No.	Calibrated Until
ADVANTEST SPECTRUM ANALYZER	U3772	160100280	April 10, 2008

**NOTE:**

- 1.The measurement uncertainty is less than +/- 2.6dB, which is calculated as per the NAMAS document NIS81.
- 2.The calibration interval of the above test instruments is 12 months and the calibrations are traceable to NML/ROC and NIST/USA.

#### 4.3.3 TEST PROCEDURE

1. The transmitter output was connected to the spectrum analyzer.
2. Set span to encompass the entire emission bandwidth of the signal.
3. Set RBW to 1MHz, VBW to 300kHz.
4. Using the spectrum analyzer's channel power measurement function to measure the output power.

**NOTE:**

The test is performed in accordance with FCC Public Notice: APPENDIX A Guidelines for Assessing Unlicensed National Information Infrastructure (U-NII) Devices – Part 15, Subpart E, August 2002.

The transmitter output operates continuously therefore Method # 1 is used.

#### 4.3.4 DEVIATION FROM TEST STANDARD

No deviation

#### 4.3.5 TEST SETUP

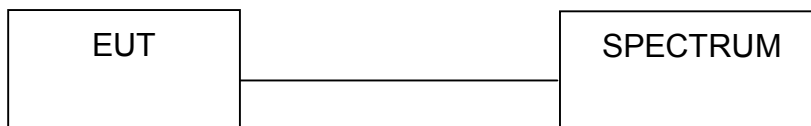

#### 4.3.6 EUT OPERATING CONDITIONS

The software provided by client to enable the EUT under transmission condition continuously at specific channel frequencies individually.



#### 4.3.7 TEST RESULTS

##### 802.11a OFDM MODULATION:

<b>MODULATION TYPE</b>	BPSK	<b>TRANSFER RATE</b>	6Mbps
<b>INPUT POWER (SYSTEM)</b>	120Vac, 60 Hz	<b>ENVIRONMENTAL CONDITIONS</b>	20deg.C, 60%RH, 972hPa
<b>TESTED BY</b>	Rex Huang		

CHANNEL	CHANNEL FREQUENCY (MHz)	PEAK POWER OUTPUT (dBm)	PEAK POWER OUTPUT (mW)	PEAK POWER LIMIT (dBm)	26dBc Occupied Bandwidth (MHz)	PASS/FAIL
1	5180	13.92	24.660	17	20.58	PASS
4	5240	14.85	30.549	17	20.58	PASS
5	5260	15.16	32.810	24	20.51	PASS
8	5320	15.18	32.961	24	22.57	PASS
9	5500	13.12	20.512	24	20.61	PASS
14	5600	11.53	14.223	24	20.55	PASS
19	5700	13.37	21.727	24	20.58	PASS

**NOTE:** The 26dBc Occupied Bandwidth plot, please refer to the following pages.

Peak Power Output:  
CH1

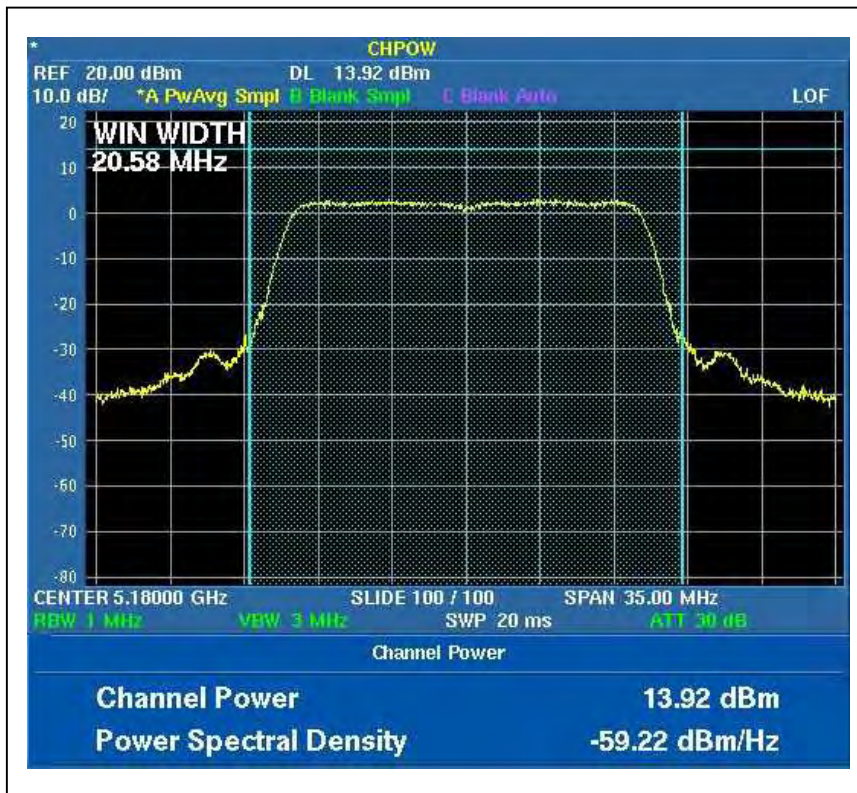

CH4

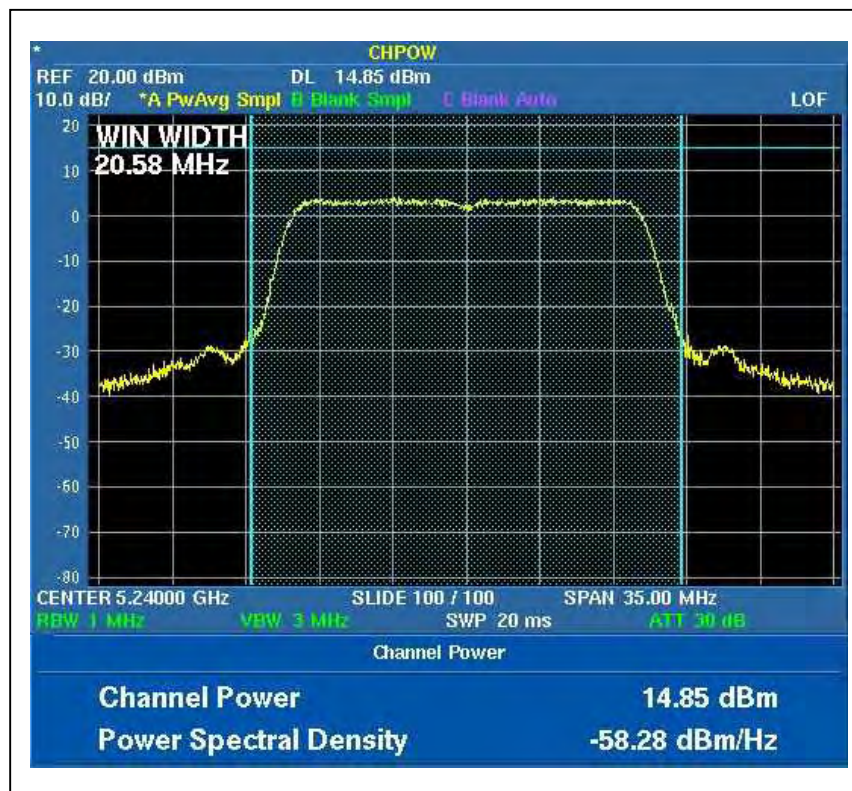

CH5

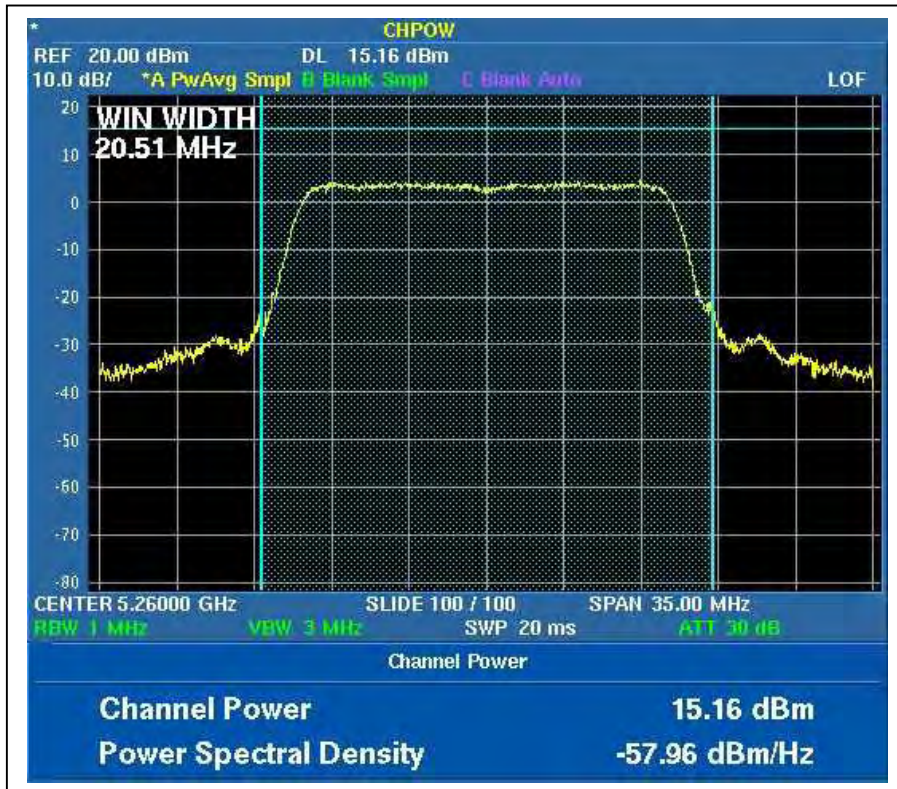

CH8

