



# FCC TEST REPORT (15.407)

**REPORT NO.:** RF120614E05-1

**MODEL NO.:** WUMC710

**FCC ID:** Q87-WUMC710

**RECEIVED:** June 22, 2012

**TESTED:** June 27 to July 04, 2012

**ISSUED:** July 12, 2012

**APPLICANT:** Cisco Consumer Products LLC

**ADDRESS:** 121 Theory Drive Irvine, CA 92617(USA)

**ISSUED BY:** Bureau Veritas Consumer Products Services  
(H.K.) Ltd., Taoyuan Branch Hsin Chu Laboratory

**LAB ADDRESS :** No. 81-1, Lu Liao Keng, 9th Ling, Wu Lung Tsuen,  
Chiung Lin Hsiang, Hsin Chu Hsien 307, Taiwan,  
R.O.C.

**TEST LOCATION (1):** No. 81-1, Lu Liao Keng, 9th Ling, Wu Lung Tsuen,  
Chiung Lin Hsiang, Hsin Chu Hsien 307, Taiwan,  
R.O.C.

**TEST LOCATION (2):** No. 49, Ln. 206, Wende Rd., Shangshan Tsuen,  
Chiung Lin Hsiang, Hsin Chu Hsien 307, Taiwan,  
R.O.C.

This report should not be used by the client to claim product certification, approval, or endorsement by TAF or any government agencies.



This report is for your exclusive use. Any copying or replication of this report to or for any other person or entity, or use of our name or trademark, is permitted only with our prior written permission. This report sets forth our findings solely with respect to the test samples identified herein. The results set forth in this report are not indicative or representative of the quality or characteristics of the lot from which a test sample was taken or any similar or identical product unless specifically and expressly noted. Our report includes all of the tests requested by you and the results thereof based upon the information that you provided to us. You have 60 days from date of issuance of this report to notify us of any material error or omission caused by our negligence, provided, however, that such notice shall be in writing and shall specifically address the issue you wish to raise. A failure to raise such issue within the prescribed time shall constitute your unqualified acceptance of the completeness of this report, the tests conducted and the correctness of the report contents. Unless specific mention, the uncertainty of measurement has been explicitly taken into account to declare the compliance or non-compliance to the specification



A D T

## Table of Contents

RELEASE CONTROL RECORD .....	4
1. CERTIFICATION .....	5
2. SUMMARY OF TEST RESULTS .....	6
2.1 MEASUREMENT UNCERTAINTY .....	7
3. GENERAL INFORMATION .....	8
3.1 GENERAL DESCRIPTION OF EUT .....	8
3.2 DESCRIPTION OF TEST MODES .....	11
3.2.1 TEST MODE APPLICABILITY AND TESTED CHANNEL DETAIL .....	12
3.3 GENERAL DESCRIPTION OF APPLIED STANDARDS .....	14
3.4 DUTY CYCLE OF TEST SIGNAL .....	14
3.5 DESCRIPTION OF SUPPORT UNITS .....	15
3.6 CONFIGURATION OF SYSTEM UNDER TEST .....	16
4. TEST TYPES AND RESULTS .....	17
4.1 CONDUCTED EMISSION MEASUREMENT .....	17
4.1.1 LIMITS OF CONDUCTED EMISSION MEASUREMENT .....	17
4.1.2 TEST INSTRUMENTS .....	17
4.1.3 TEST PROCEDURES .....	18
4.1.4 DEVIATION FROM TEST STANDARD .....	18
4.1.5 TEST SETUP .....	19
4.1.6 EUT OPERATING CONDITIONS .....	19
4.1.7 TEST RESULTS (MODE 1) .....	20
4.1.8 TEST RESULTS (MODE 2) .....	22
4.2 RADIATED EMISSION AND BANDEDGE MEASUREMENT .....	24
4.2.1 LIMITS OF RADIATED EMISSION AND BANDEDGE MEASUREMENT .....	24
4.2.2 LIMITS OF UNWANTED EMISSION OUT OF THE RESTRICTED BANDS .....	25
4.2.3 TEST INSTRUMENTS .....	26
4.2.4 TEST PROCEDURES .....	28
4.2.5 DEVIATION FROM TEST STANDARD .....	28
4.2.6 TEST SETUP .....	29
4.2.7 EUT OPERATING CONDITION .....	29
4.2.8 TEST RESULTS .....	30
4.3 TRANSMIT POWER MEASUREMENT .....	40
4.3.1 LIMITS OF TRANSMIT POWER MEASUREMENT .....	40
4.3.2 TEST INSTRUMENTS .....	40
4.3.3 TEST PROCEDURE .....	40
4.3.4 DEVIATION FROM TEST STANDARD .....	41
4.3.5 TEST SETUP .....	41
4.3.6 EUT OPERATING CONDITIONS .....	41
4.3.7 TEST RESULTS .....	42
4.4 PEAK POWER SPECTRAL DENSITY MEASUREMENT .....	44
4.4.1 LIMITS OF PEAK POWER SPECTRAL DENSITY MEASUREMENT .....	44
4.4.2 TEST INSTRUMENTS .....	44
4.4.3 TEST PROCEDURES .....	44
4.4.4 DEVIATION FROM TEST STANDARD .....	44
4.4.5 TEST SETUP .....	45
4.4.6 EUT OPERATING CONDITIONS .....	45
4.4.7 TEST RESULTS .....	46
4.5 PEAK POWER EXCURSION MEASUREMENT .....	48
4.5.1 LIMITS OF PEAK POWER EXCURSION MEASUREMENT .....	48



A D T

4.5.2	TEST INSTRUMENTS .....	48
4.5.3	TEST PROCEDURE .....	48
4.5.4	DEVIATION FROM TEST STANDARD.....	48
4.5.5	TEST SETUP .....	48
4.5.6	EUT OPERATING CONDITIONS .....	48
4.5.7	TEST RESULTS .....	49
4.6	FREQUENCY STABILITY .....	57
4.6.1	LIMITS OF FREQUENCY STABILITY MEASUREMENT .....	57
4.6.2	TEST INSTRUMENTS .....	57
4.6.3	TEST PROCEDURE .....	57
4.6.4	DEVIATION FROM TEST STANDARD.....	58
4.6.5	TEST SETUP .....	58
4.6.6	EUT OPERATING CONDITION.....	58
4.6.7	TEST RESULTS .....	59
5.	PHOTOGRAPHS OF THE TEST CONFIGURATION.....	60
6.	INFORMATION ON THE TESTING LABORATORIES .....	61
7.	APPENDIX A - MODIFICATIONS RECORDERS FOR ENGINEERING CHANGES TO THE EUT BY THE LAB .....	62



A D T

## RELEASE CONTROL RECORD

ISSUE NO.	REASON FOR CHANGE	DATE ISSUED
RF120614E05-1	Original release	July 12, 2012



A D T

## 1. CERTIFICATION

**PRODUCT:** 802.11ac Wireless Ethernet Bridge  
**BRAND NAME:** Cisco  
**MODEL NO.:** WUMC710  
**TEST SAMPLE:** ENGINEERING SAMPLE  
**APPLICANT:** Cisco Consumer Products LLC  
**TESTED:** June 27 to July 04, 2012  
**STANDARDS:** **FCC Part 15, Subpart E (Section 15.407)**  
ANSI C63.10-2009

The above equipment (Model: WUMC710) has been tested by **Bureau Veritas Consumer Products Services (H.K.) Ltd., Taoyuan Branch**, and found compliance with the requirement of the above standards. The test record, data evaluation & Equipment Under Test (EUT) configurations represented herein are true and accurate accounts of the measurements of the sample's EMC characteristics under the conditions specified in this report.

**PREPARED BY** : Phoenix Huang , **DATE:** July 12, 2012  
( Phoenix Huang, Specialist )

**APPROVED BY** : May Chen , **DATE:** July 12, 2012  
( May Chen, Deputy Manager )

## 2. SUMMARY OF TEST RESULTS

The EUT has been tested according to the following specifications:

APPLIED STANDARD: FCC PART 15, SUBPART E (SECTION 15.407)			
STANDARD SECTION	TEST TYPE	RESULT	REMARK
15.407(b)(6)	AC Power Conducted Emission	PASS	Meet the requirement of limit. Minimum passing margin is -6.17dB at 0.15391MHz
15.407(b/1/2/3)(b)(6)	Spurious Emissions	PASS	Meet the requirement of limit. Minimum passing margin is -0.6dB at 5150.00MHz.
15.407(a/1/2)	Peak Transmit Power	PASS	Meet the requirement of limit.
15.407(a)(6)	Peak Power Excursion	PASS	Meet the requirement of limit.
15.407(a/1/2)	Peak Power Spectral Density	PASS	Meet the requirement of limit.
15.407(g)	Frequency Stability	PASS	Meet the requirement of limit.
15.203	Antenna Requirement	PASS	Antenna connector is IPEX not a standard connector.

### NOTE:

1. The EUT was operating in 5.15~5.25GHz and 5.725~5.850GHz frequencies band. This report was recorded the RF parameters including 5.15~5.25GHz. For the 5.725~5.850GHz RF parameters was recorded in another test report.



A D T

## 2.1 MEASUREMENT UNCERTAINTY

Where relevant, the following measurement uncertainty levels have been estimated for tests performed on the EUT as specified in CISPR 16-4-2:

This uncertainty represents an expanded uncertainty expressed at approximately the 95% confidence level using a coverage factor of  $k=2$ .

Measurement	Value
Conducted emissions	2.98 dB
Radiated emissions (30MHz-1GHz)	5.69 dB
Radiated emissions (1GHz -6GHz)	3.56 dB
Radiated emissions (6GHz -18GHz)	4.10 dB
Radiated emissions (18GHz -40GHz)	4.24 dB



A D T

### 3. GENERAL INFORMATION

#### 3.1 GENERAL DESCRIPTION OF EUT

<b>PRODUCT</b>	802.11ac Wireless Ethernet Bridge
<b>MODEL NO.</b>	WUMC710
<b>POWER SUPPLY</b>	DC 12V from power adapter
<b>MODULATION TYPE</b>	64QAM, 16QAM, QPSK, BPSK for OFDM 256QAM for OFDM in 11ac mode only.
<b>MODULATION TECHNOLOGY</b>	OFDM
<b>TRANSFER RATE</b>	802.11a: up to 54Mbps 802.11n: up to 450Mbps 802.11ac: up to 1300Mbps
<b>OPERATING FREQUENCY</b>	<b>For 15.407</b> 802.11a/n/ac: 5.18 ~ 5.24GHz
	<b>For 15.247</b> 802.11a/n/ac: 5.745 ~ 5.825GHz
<b>NUMBER OF CHANNEL</b>	<b>For 15.407</b> 4 for 802.11a, 802.11n (HT20), 802.11ac (VHT20) 2 for 802.11n (HT40), 802.11ac (VHT40) 1 for 802.11ac (VHT80)
	<b>For 15.247</b> 5 for 802.11a, 802.11n (HT20), 802.11ac (VHT20) 2 for 802.11n (HT40), 802.11ac (VHT40) 1 for 802.11ac (VHT80)
<b>MAXIMUM OUTPUT POWER</b>	<b>For 15.407</b> 802.11a: 13.196mW 802.11n (HT20): 28.954mW 802.11n (HT40): 47.349mW 802.11ac (VHT80): 48.464mW <b>For 15.247</b> 802.11a: 171.845mW 802.11n (HT20): 169.758mW 802.11n (HT40): 240.256mW 802.11ac (VHT80): 328.245mW



<b>ANTENNA TYPE</b>	Please see NOTE
<b>DATA CABLE</b>	UTP cable (1.5m) × 1
<b>I/O PORTS</b>	Refer to user's manual
<b>ASSOCIATED DEVICES</b>	Adapter x 1

**NOTE:**

1. The EUT has two transformers and following below:

No.	Model	Transformer
1	WUMC710	TAG Transformer Model : GC3601A
2		Mingtek Transformer Model : HN36201CG

Above two transformers were pre-tested in chamber, the worse case was found in transformer 1. Therefore only the test data of the model was recorded in this report.

2. The EUT must be supplied with a power adapter and following two different models could be chosen as following table:

No.	Brand	Model No.	Spec.
1	HON-KWANG	HK-AX-120A150-US	Input: 100-240V, 0.8A, 50/60Hz Output: 12V, 1.5A DC output cable: (1.5m, unshielded)
2	SOLYTECH	CAD1812C	Input: 100-240V, 1.0A, 50-60Hz Output: 12V, 1.5A DC output cable: (1.5m, unshielded)

Above two adapters were pre-tested in chamber, the radiated emission worse case was found in adapter 2. Therefore only the test data of the model was recorded in this report.

3. The EUT incorporates a MIMO function.

MODULATION MODE	TX/RX FUNCTION
<b>802.11a</b>	3Tx/3Rx
<b>802.11n (HT20)</b>	3Tx/3Rx
<b>802.11n (HT40)</b>	3Tx/3Rx
<b>802.11n (VHT20)</b>	3Tx/3Rx
<b>802.11ac(VHT40)</b>	3Tx/3Rx
<b>802.11ac (VHT80)</b>	3Tx/3Rx

Note: The modulation and bandwidth are similar for 11n mode for 20MHz (40MHz) and 11ac mode for 20MHz (40MHz), therefore investigated worst case to representative mode in test report. (Final test mode refer section 3.2.1)



A D T

4. The antennas provided to the EUT, please refer to the following table:

Transmitter Circuit	Antenna Type	Gain (dBi) (Include cable loss)	Frequency range (MHz to MHz)	Cable Loss (dB)	Cable Length (cm)
Chain (0)	Balanced	4.87	5150 – 5825	0.8	13
Chain (1)	Balanced	4.49	5150 – 5825	0.73	12.7
Chain (2)	Balanced	4.04	5150 – 5825	0.85	15.5

5. When the EUT operating in 802.11n, the software operation, which is defined by manufacturer, MCS (Modulation and Coding Schemes) from 0 to 23.

6. When the EUT operating in 802.11ac, the software operation, which is defined by manufacturer, MCS (Modulation and Coding Schemes) from 0 to 9.

7. The above EUT information was declared by the manufacturer and for more detailed features description, please refer to the manufacturer's specifications or User's Manual.



A D T

### 3.2 DESCRIPTION OF TEST MODES

Four channels are provided for 802.11a, 802.11n (HT20), 802.11ac (VHT20):

CHANNEL	FREQUENCY
36	5180 MHz
40	5200 MHz
44	5220 MHz
48	5240 MHz

Two channels are provided for 802.11n (HT40), 802.11ac (VHT40):

CHANNEL	FREQUENCY
38	5190 MHz
46	5230 MHz

One channel is provided for 802.11ac (VHT80):

CHANNEL	FREQUENCY
42	5210 MHz

### 3.2.1 TEST MODE APPLICABILITY AND TESTED CHANNEL DETAIL

EUT CONFIGURE MODE	APPLICABLE TO				DESCRIPTION
	PLC	RE < 1G	RE ≥ 1G	APCM	
1	√	-	-	-	With Adapter 1
2	√	√	√	√	With Adapter 2

Where **PLC**: Power Line Conducted Emission                      **RE < 1G**: Radiated Emission below 1GHz  
**RE ≥ 1G**: Radiated Emission above 1GHz                      **APCM**: Antenna Port Conducted Measurement

#### **POWER LINE CONDUCTED EMISSION TEST:**

- Pre-Scan has been conducted to determine the worst-case mode from all possible combinations between available modulations, data rates and antenna ports (if EUT with antenna diversity architecture).
- Following channel(s) was (were) selected for the final test as listed below.

MODE	AVAILABLE CHANNEL	TESTED CHANNEL	MODULATION TECHNOLOGY	MODULATION TYPE	DATA RATE (MBPS)
802.11n (HT20)	36 to 48	40	OFDM	BPSK	6.5

#### **RADIATED EMISSION TEST (BELOW 1 GHz):**

- Pre-Scan has been conducted to determine the worst-case mode from all possible combinations between available modulations, data rates and antenna ports (if EUT with antenna diversity architecture).
- Following channel(s) was (were) selected for the final test as listed below.

MODE	AVAILABLE CHANNEL	TESTED CHANNEL	MODULATION TECHNOLOGY	MODULATION TYPE	DATA RATE (Mbps)
802.11n (HT20)	36 to 48	40	OFDM	BPSK	6.5



A D T

**RADIATED EMISSION TEST (ABOVE 1 GHZ):**

- Pre-Scan has been conducted to determine the worst-case mode from all possible combinations between available modulations, data rates and antenna ports (if EUT with antenna diversity architecture).
- Following channel(s) was (were) selected for the final test as listed below.

MODE	AVAILABLE CHANNEL	TESTED CHANNEL	MODULATION TECHNOLOGY	MODULATION TYPE	DATA RATE (Mbps)
802.11a	36 to 48	36, 40, 48	OFDM	BPSK	6
802.11n (HT20)	36 to 48	36, 40, 48	OFDM	BPSK	6.5
802.11n (HT40)	38 to 46	38, 46	OFDM	BPSK	13.5
802.11ac (VHT80)	42	42	OFDM	BPSK	97.5

**ANTENNA PORT CONDUCTED MEASUREMENT:**

- Pre-Scan has been conducted to determine the worst-case mode from all possible combinations between available modulations, data rates and antenna ports (if EUT with antenna diversity architecture).
- Following channel(s) was (were) selected for the final test as listed below.

MODE	AVAILABLE CHANNEL	TESTED CHANNEL	MODULATION TECHNOLOGY	MODULATION TYPE	DATA RATE (Mbps)
802.11a	36 to 48	36, 40, 48	OFDM	BPSK	6
802.11n (HT20)	36 to 48	36, 40, 48	OFDM	BPSK	6.5
802.11n (HT40)	38 to 46	38, 46	OFDM	BPSK	13.5
802.11ac (VHT80)	42	42	OFDM	BPSK	97.5

**TEST CONDITION:**

APPLICABLE TO	ENVIRONMENTAL CONDITIONS	INPUT POWER	TESTED BY
PLC	25deg. C, 65%RH	120Vac, 60Hz	Kyle Huang
RE<1G	22deg. C, 68%RH	120Vac, 60Hz	Evan Huang
RE <sup>3</sup> 1G	22deg. C, 61%RH	120Vac, 60Hz	Amos Chuang
APCM	25deg. C, 60%RH	120Vac, 60Hz	Rex Huang

### 3.3 GENERAL DESCRIPTION OF APPLIED STANDARDS

The EUT is a RF product. According to the specifications of the manufacturer, it must comply with the requirements of the following standards:

#### FCC Part 15, Subpart E (15.407)

#### 789033 D01 General UNII Test Procedures v01r01

#### ANSI C63.10-2009

All test items have been performed and recorded as per the above standards.

**Note:** The EUT has been verified to comply with the requirements of FCC Part 15, Subpart B, Class B (DoC). The test report has been issued separately.

### 3.4 DUTY CYCLE OF TEST SIGNAL

Test tool can set the EUT to transmit at > 98 % duty cycle.

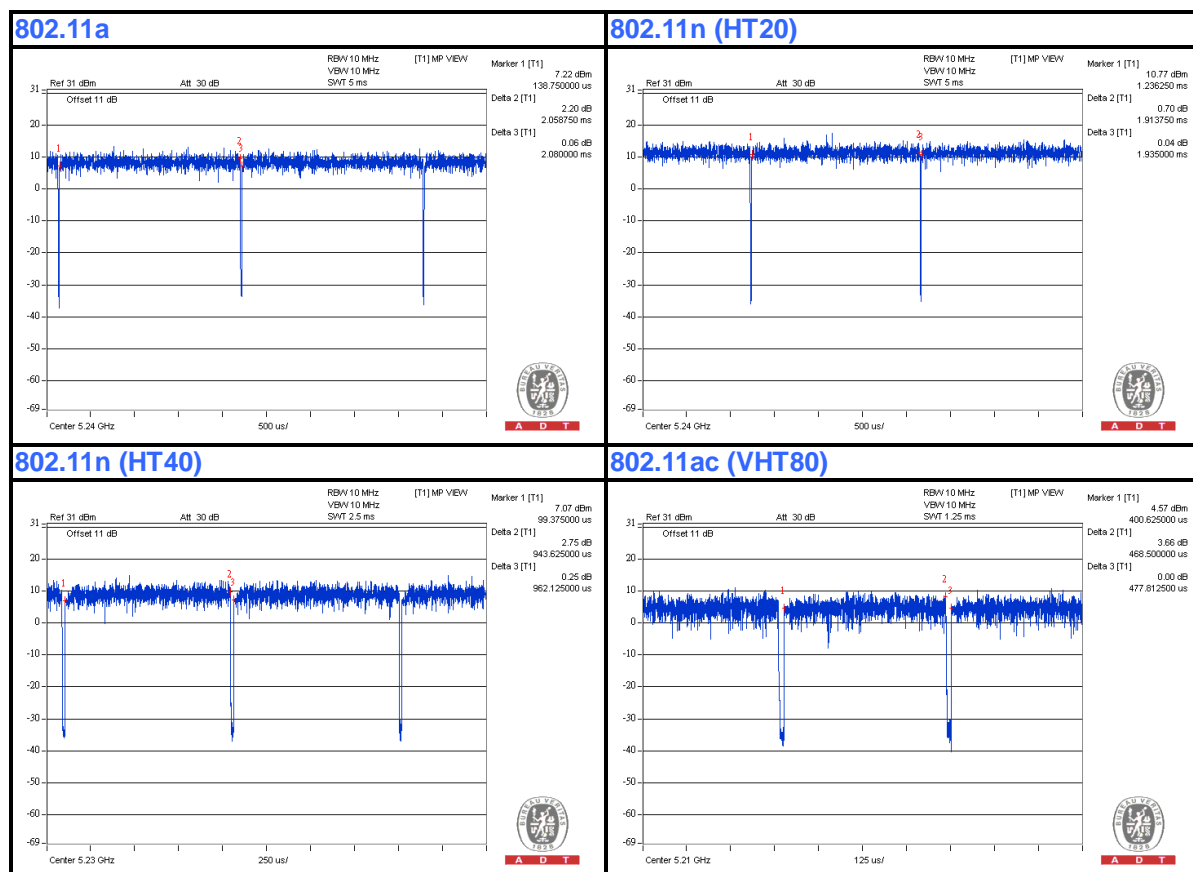



A D T

### 3.5 DESCRIPTION OF SUPPORT UNITS

The EUT has been tested as an independent unit together with other necessary accessories or support units. The following support units or accessories were used to form a representative test configuration during the tests.

NO.	PRODUCT	BRAND	MODEL NO.	SERIAL NO.	FCC ID
1	NOTEBOOK COMPUTER	DELL	PP32LA	FSLB32S	FCC DoC
2	HUB	ZyXEL	ES-116P	S060H0200021 5	FCC DoC

NO.	SIGNAL CABLE DESCRIPTION OF THE ABOVE SUPPORT UNITS
1	UTP cable, 10m
2	UTP cable, 10m

**NOTE:** All power cords of the above support units are non shielded (1.8m).

### 3.6 CONFIGURATION OF SYSTEM UNDER TEST

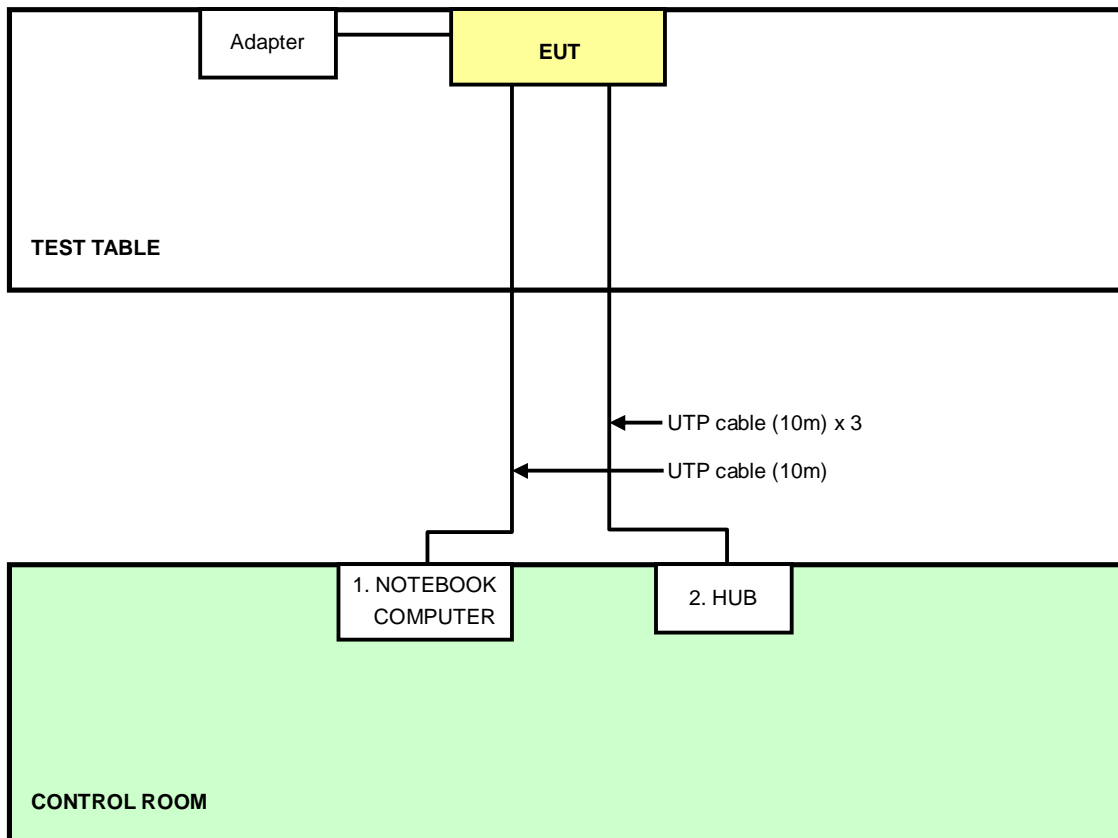





A D T

## 4. TEST TYPES AND RESULTS

### 4.1 CONDUCTED EMISSION MEASUREMENT

#### 4.1.1 LIMITS OF CONDUCTED EMISSION MEASUREMENT

FREQUENCY OF EMISSION (MHz)	CONDUCTED LIMIT (dB $\mu$ V)	
	Quasi-peak	Average
0.15-0.5	66 to 56	56 to 46
0.5-5	56	46
5-30	60	50

- NOTE:**
1. The lower limit shall apply at the transition frequencies.
  2. The limit decreases in line with the logarithm of the frequency in the range of 0.15 to 0.50 MHz.

#### 4.1.2 TEST INSTRUMENTS

DESCRIPTION & MANUFACTURER	MODEL NO.	SERIAL NO.	CALIBRATED DATE	CALIBRATED UNTIL
Test Receiver ROHDE & SCHWARZ	ESCS 30	100287	Feb. 29, 2012	Feb. 28, 2013
Line-Impedance Stabilization Network (for EUT) SCHWARZBECK	NSLK 8127	8127-523	Sep. 20, 2011	Sep. 19, 2012
Line-Impedance Stabilization Network (for Peripheral) ROHDE & SCHWARZ	ESH3-Z5	848773/004	Nov. 01, 2011	Oct. 31, 2012
RF Cable (JYBAO)	5DFB	COACAB-002	Aug. 06, 2011	Aug. 05, 2012
50 ohms Terminator	50	3	Nov. 02, 2011	Nov. 01, 2012
Software ADT	BV ADT_Cond_V7.3.7 .3	NA	NA	NA

**Note:**

1. The calibration interval of the above test instruments is 12 months and the calibrations are traceable to NML/ROC and NIST/USA.
2. The test was performed in Shielded Room No. A.
3. The VCCI Con A Registration No. is C-817.
4. Tested Date: June 28, 2012



A D T

#### 4.1.3 TEST PROCEDURES

- a. The EUT was placed 0.4 meters from the conducting wall of the shielded room with EUT being connected to the power mains through a line impedance stabilization network (LISN). Other support units were connected to the power mains through another LISN.
- b. The two LISNs provide 50 ohm/ 50uH of coupling impedance for the measuring instrument.
- c. Both lines of the power mains connected to the EUT were checked for maximum conducted interference.
- d. The frequency range from 150kHz to 30MHz was searched. Emission level under (Limit – 20dB) was not recorded.

#### 4.1.4 DEVIATION FROM TEST STANDARD

No deviation

#### 4.1.5 TEST SETUP

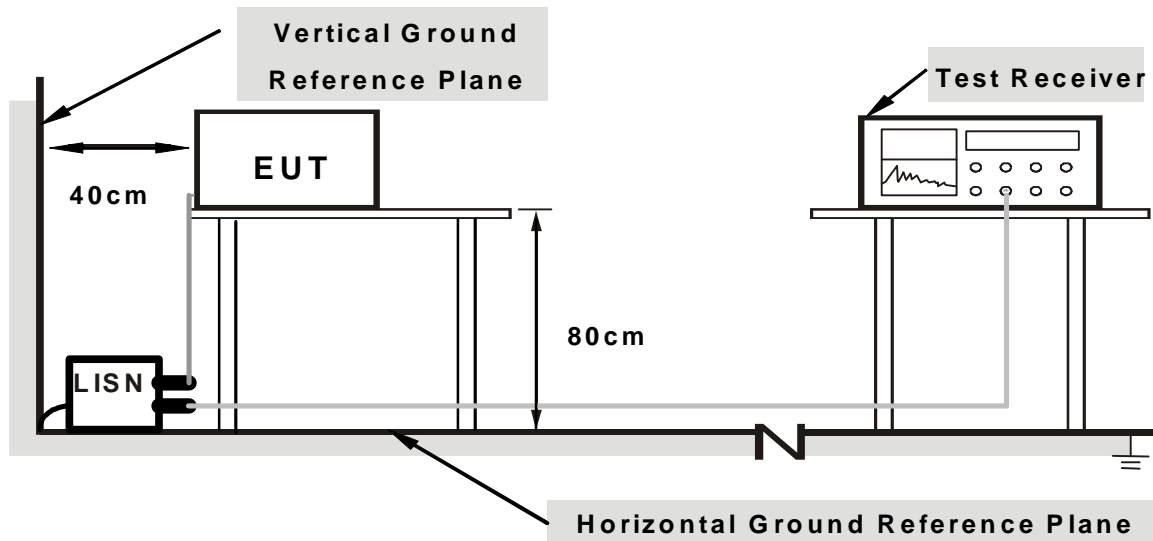

**Note: 1. Support units were connected to second LISN.**

**2. Both of LISNs (AMN) are 80 cm from EUT and at least 80 from other units and other metal planes**

For the actual test configuration, please refer to the related item – Photographs of the Test Configuration.

#### 4.1.6 EUT OPERATING CONDITIONS

1. Placed the EUT on testing table.
2. Prepared other computer system (support unit 1) to act as communication partners and placed them outside of testing area.
3. The communication partners ran test program “MTool.exe v1.0.0.9” to enable EUT under transmission/receiving condition continuously via one UTP cable.

### 4.1.7 TEST RESULTS (MODE 1)

<b>PHASE</b>	Line (L)	<b>6dB BANDWIDTH</b>	9 kHz
--------------	----------	----------------------	-------

No	Freq.	Corr. Factor	Reading Value		Emission Level		Limit		Margin	
	[MHz]		[dB (uV)]		[dB (uV)]		[dB (uV)]		(dB)	
			Q.P.	AV.	Q.P.	AV.	Q.P.	AV.	Q.P.	AV.
1	0.15391	0.06	59.56	49.09	59.62	49.15	65.79	55.79	-6.17	-6.64
2	0.19297	0.06	51.46	36.34	51.52	36.40	63.91	53.91	-12.39	-17.51
3	0.23984	0.06	42.59	27.97	42.65	28.03	62.10	52.10	-19.45	-24.07
4	0.45078	0.07	43.49	36.39	43.56	36.46	56.86	46.86	-13.30	-10.40
5	0.99375	0.12	38.89	29.58	39.01	29.70	56.00	46.00	-16.99	-16.30
6	6.33984	0.32	39.09	30.99	39.41	31.31	60.00	50.00	-20.59	-18.69

**REMARKS:**

1. Q.P. and AV. are abbreviations of quasi-peak and average individually.
2. The emission levels of other frequencies were very low against the limit.
3. Margin value = Emission level - Limit value
4. Correction factor = Insertion loss + Cable loss
5. Emission Level = Correction Factor + Reading Value.

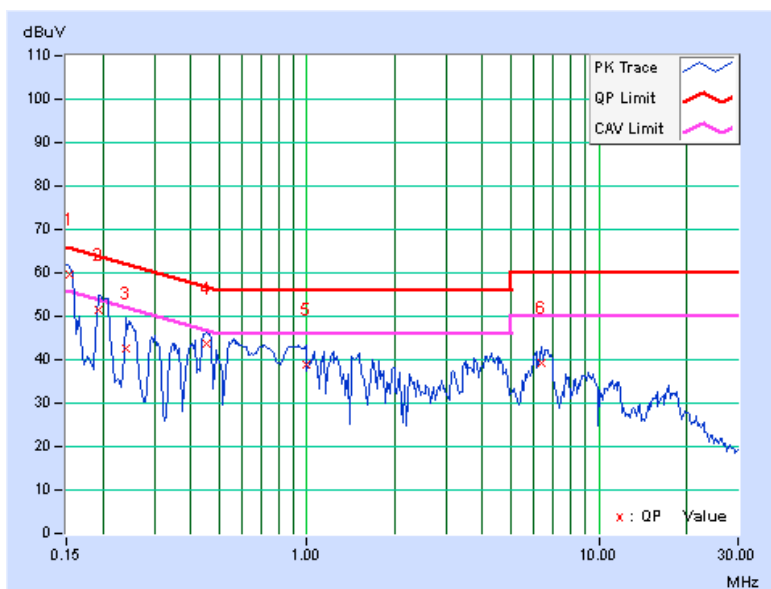

<b>PHASE</b>	Neutral (N)	<b>6dB BANDWIDTH</b>	9 kHz
--------------	-------------	----------------------	-------

No	Freq.	Corr. Factor	Reading Value		Emission Level		Limit		Margin	
	[MHz]		[dB (uV)]		[dB (uV)]		[dB (uV)]		(dB)	
			Q.P.	AV.	Q.P.	AV.	Q.P.	AV.	Q.P.	AV.
1	0.19687	0.07	52.68	41.01	52.75	41.08	63.74	53.74	-10.99	-12.66
2	0.24766	0.07	46.13	35.62	46.20	35.69	61.84	51.84	-15.63	-16.14
3	0.50547	0.09	41.04	33.56	41.13	33.65	56.00	46.00	-14.87	-12.35
4	2.08984	0.18	36.83	26.74	37.01	26.92	56.00	46.00	-18.99	-19.08
5	6.94531	0.31	35.80	27.67	36.11	27.98	60.00	50.00	-23.89	-22.02
6	17.00781	0.54	36.82	30.60	37.36	31.14	60.00	50.00	-22.64	-18.86

**REMARKS:**

1. Q.P. and AV. are abbreviations of quasi-peak and average individually.
2. The emission levels of other frequencies were very low against the limit.
3. Margin value = Emission level - Limit value
4. Correction factor = Insertion loss + Cable loss
5. Emission Level = Correction Factor + Reading Value.

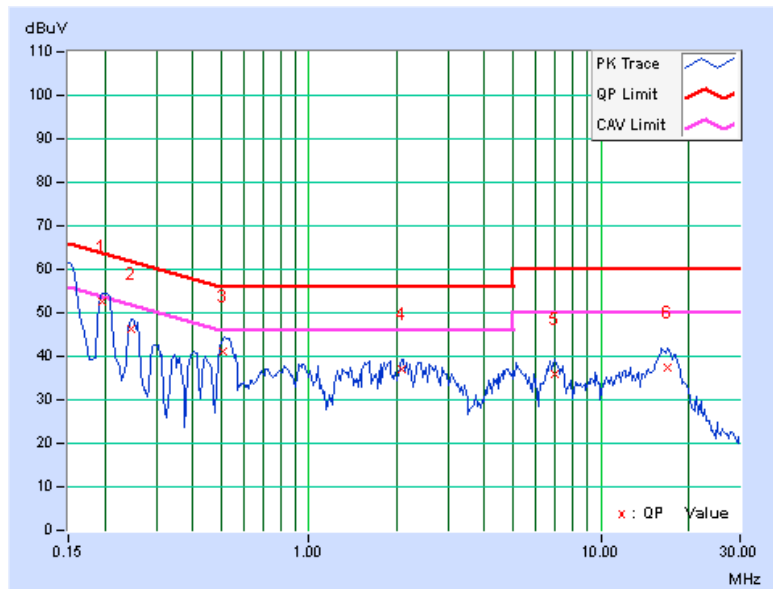

### 4.1.8 TEST RESULTS (MODE 2)

<b>PHASE</b>	Line (L)	<b>6dB BANDWIDTH</b>	9 kHz
--------------	----------	----------------------	-------

No	Freq. [MHz]	Corr. Factor (dB)	Reading Value [dB (uV)]		Emission Level [dB (uV)]		Limit [dB (uV)]		Margin (dB)	
			Q.P.	AV.	Q.P.	AV.	Q.P.	AV.	Q.P.	AV.
			1	0.15391	0.06	48.58	35.78	48.64	35.84	65.79
2	0.20469	0.06	38.82	29.69	38.88	29.75	63.42	53.42	-24.54	-23.67
3	0.31797	0.07	34.78	24.17	34.85	24.24	59.76	49.76	-24.91	-25.52
4	0.45469	0.07	25.39	11.31	25.46	11.38	56.79	46.79	-31.32	-35.40
5	4.11719	0.27	25.98	16.27	26.25	16.54	56.00	46.00	-29.75	-29.46
6	12.62891	0.46	31.41	28.40	31.87	28.86	60.00	50.00	-28.13	-21.14

#### REMARKS:

1. Q.P. and AV. are abbreviations of quasi-peak and average individually.
2. The emission levels of other frequencies were very low against the limit.
3. Margin value = Emission level - Limit value
4. Correction factor = Insertion loss + Cable loss
5. Emission Level = Correction Factor + Reading Value.

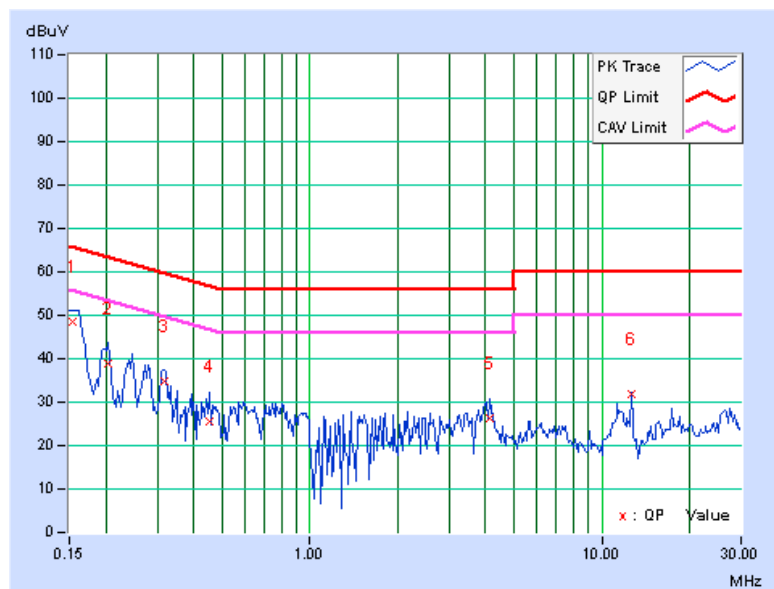

<b>PHASE</b>	Neutral (N)	<b>6dB BANDWIDTH</b>	9 kHz
--------------	-------------	----------------------	-------

No	Freq. [MHz]	Corr. Factor (dB)	Reading Value [dB (uV)]		Emission Level [dB (uV)]		Limit [dB (uV)]		Margin (dB)	
			Q.P.	AV.	Q.P.	AV.	Q.P.	AV.	Q.P.	AV.
			1	0.16562	0.07	46.19	41.82	46.26	41.89	65.18
2	0.24375	0.07	38.14	24.40	38.21	24.47	61.97	51.97	-23.76	-27.50
3	0.31797	0.08	35.37	25.67	35.45	25.75	59.76	49.76	-24.31	-24.01
4	0.95859	0.12	26.53	15.94	26.65	16.06	56.00	46.00	-29.35	-29.94
5	4.06250	0.25	27.43	16.77	27.68	17.02	56.00	46.00	-28.32	-28.98
6	12.63281	0.44	30.77	28.34	31.21	28.78	60.00	50.00	-28.79	-21.22

**REMARKS:**

1. Q.P. and AV. are abbreviations of quasi-peak and average individually.
2. The emission levels of other frequencies were very low against the limit.
3. Margin value = Emission level - Limit value
4. Correction factor = Insertion loss + Cable loss
5. Emission Level = Correction Factor + Reading Value.

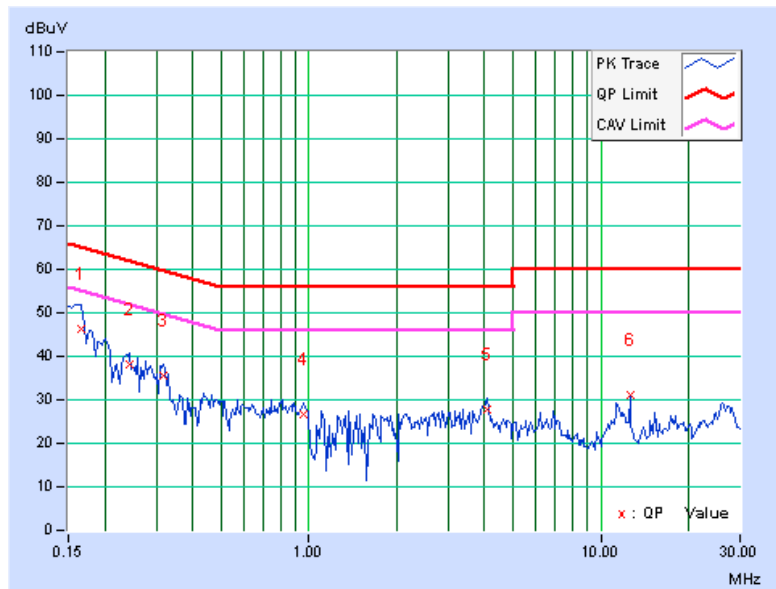

## 4.2 RADIATED EMISSION AND BANDEDGE MEASUREMENT

### 4.2.1 LIMITS OF RADIATED EMISSION AND BANDEDGE MEASUREMENT

Radiated emissions which fall in the restricted bands must comply with the radiated emission limits specified as below table:

Frequencies (MHz)	Field strength (microvolts/meter)	Measurement distance (meters)
0.009-0.490	2400/F(kHz)	300
0.490-1.705	24000/F(kHz)	30
1.705-30.0	30	30
30-88	100	3
88-216	150	3
216-960	200	3
Above 960	500	3

**NOTE:**

1. The lower limit shall apply at the transition frequencies.
2. Emission level (dBuV/m) = 20 log Emission level (uV/m).
3. For frequencies above 1000MHz, the field strength limits are based on average detector, however, the peak field strength of any emission shall not exceed the maximum permitted average limits, specified above by more than 20dB under any condition of modulation.





A D T

#### 4.2.2 LIMITS OF UNWANTED EMISSION OUT OF THE RESTRICTED BANDS

Frequencies (MHz)	EIRP Limit (dBm)	Equivalent Field Strength at 3m (dBµV/m) *note 3
5150~5250	-27	68.3
5250~5350	-27	68.3
5470~5725	-27	68.3
5725~5825	-27 *note 1	68.3
	-17 *note 2	78.3

**NOTE:**

1. For frequencies 10MHz or greater above or below the band edge.
2. All emissions within the frequency range from the band edge to 10MHz above or below the band edge.
3. The following formula is used to convert the equipment isotropic radiated power (eirp) to field strength

$$E = \frac{1000000\sqrt{30P}}{3} \mu\text{V/m, where P is the eirp (Watts)}$$



A D T

## 4.2.3 TEST INSTRUMENTS

### For below 1GHz

DESCRIPTION & MANUFACTURER	MODEL NO.	SERIAL NO.	CALIBRATED DATE	CALIBRATED UNTIL
Spectrum Analyzer Agilent	E4446A	MY48250253	Aug. 29, 2011	Aug. 28, 2012
Pre-Selector Agilent	N9039A	MY46520310	Aug. 29, 2011	Aug. 28, 2012
Signal Generator Agilent	N5181A	MY49060347	July 25, 2011	July 24, 2012
Pre-Amplifier Mini-Circuits	ZFL-1000VH2 B	AMP-ZFL-04	Nov. 15, 2011	Nov. 14, 2012
Pre-Amplifier Agilent	8449B	3008A02465	Feb. 27, 2012	Feb. 26, 2013
SPACEK LABS	SLKKa-48-6	9K16	Nov. 15, 2011	Nov. 14, 2012
Trilog Broadband Antenna SCHWARZBECK	VULB 9168	9168-361	Apr. 06, 2012	Apr. 05, 2013
Horn_Antenna AISI	AIH.8018	000022009111 0	Nov. 23, 2011	Nov. 22, 2012
Horn_Antenna SCHWARZBECK	BBHA 9170	9170-424	Oct. 07, 2011	Oct. 06, 2012
Loop Antenna <sup>(*)</sup> R&S	HFH2-Z2	100070	Jan. 31, 2012	Jan. 30, 2014
RF Cable	NA	RF104-205 RF104-207 RF104-202	Dec. 27, 2011	Dec. 26, 2012
RF Cable	NA	CHHCAB_001	Oct. 08, 2011	Oct. 07, 2012
Software	ADT_Radiated _V8.7.05	NA	NA	NA
Antenna Tower & Turn Table CT	NA	NA	NA	NA

#### Note:

1. The calibration interval of the above test instruments is 12 months and the calibrations are traceable to NML/ROC and NIST/USA.
2. \* = The calibration interval of the above test instruments is 24 months and the calibrations are traceable to NML/ROC and NIST/USA.
3. The horn antenna, preamplifier (model: 8449B) are used only for the measurement of emission frequency above 1GHz if tested.
4. The test was performed in 966 Chamber No. H.
5. The FCC Site Registration No. is 797305.
6. The CANADA Site Registration No. is IC 7450H-3.
7. Tested Date: June 27, 2012



A D T

**For above 1GHz**

DESCRIPTION & MANUFACTURER	MODEL NO.	SERIAL NO.	CALIBRATED DATE	CALIBRATED UNTIL
Spectrum Analyzer Agilent	E4446A	MY48250254	July 12, 2011	July 11, 2012
Pre-Selector Agilent	N9039A	MY46520311	July 12, 2011	July 11, 2012
Signal Generator Agilent	N5181A	MY49060517	July 12, 2011	July 11, 2012
Pre-Amplifier Mini-Circuits	ZFL-1000VH2 B	AMP-ZFL-03	Nov. 15, 2011	Nov. 14, 2012
Pre-Amplifier Agilent	8449B	3008A02578	July 04, 2011	July 03, 2012
Pre-Amplifier SPACEK LABS	SLKKa-48-6	9K16	Nov. 15, 2011	Nov. 14, 2012
Trilog Broadband Antenna SCHWARZBECK	VULB 9168	9168-360	Apr. 09, 2012	Apr. 08, 2013
Horn_Antenna AISI	AIH.8018	0000320091110	Nov. 14, 2011	Nov. 13, 2012
Horn_Antenna SCHWARZBECK	BBHA 9170	9170-424	Oct. 07, 2011	Oct. 06, 2012
Loop Antenna <sup>(7)</sup> R&S	HFH2-Z2	100070	Jan. 31, 2012	Jan. 30, 2014
RF Cable	NA	RF104-201 RF104-203 RF104-204	Dec. 26, 2011	Dec. 25, 2012
RF Cable	NA	CHGCAB_001	Oct. 07, 2011	Oct. 06, 2012
Software	ADT_Radiated _V8.7.05	NA	NA	NA
Antenna Tower & Turn Table CT	NA	NA	NA	NA

**Note:**

1. The calibration interval of the above test instruments is 12 months and the calibrations are traceable to NML/ROC and NIST/USA.
2. \* = The calibration interval of the above test instruments is 24 months and the calibrations are traceable to NML/ROC and NIST/USA.
3. The horn antenna, preamplifier (model: 8449B) are used only for the measurement of emission frequency above 1GHz if tested.
4. The test was performed in 966 Chamber No. G.
5. The FCC Site Registration No. is 966073.
6. The VCCI Site Registration No. is G-137.
7. The CANADA Site Registration No. is IC 7450H-2.
8. Tested Date: June 29, 2012

#### 4.2.4 TEST PROCEDURES

- a. The EUT was placed on the top of a rotating table 0.8 meters above the ground at 3 meter chamber room for test. The table was rotated 360 degrees to determine the position of the highest radiation.
- b. The EUT was set 3 meters away from the interference-receiving antenna, which was mounted on the top of a variable-height antenna tower.
- c. The height of antenna is varied from one meter to four meters above the ground to determine the maximum value of the field strength. Both horizontal and vertical polarizations of the antenna are set to make the measurement.
- d. For each suspected emission, the EUT was arranged to its worst case and then the antenna was tuned to heights from 1 meter to 4 meters and the rotatable table was turned from 0 degrees to 360 degrees to find the maximum reading.
- e. The test-receiver system was set to quasi-peak detect function and specified bandwidth with maximum hold mode when the test frequency is below 1 GHz.
- f. The test-receiver system was set to peak and average detect function and specified bandwidth with maximum hold mode when the test frequency is above 1 GHz. If the peak reading value also meets average limit, measurement with the average detector is unnecessary.

**NOTE:**

1. The resolution bandwidth and video bandwidth of test receiver/spectrum analyzer is 120kHz for Quasi-peak detection (QP) at frequency below 1GHz.
2. The resolution bandwidth of test receiver/spectrum analyzer is 1 MHz and the video bandwidth is 3 MHz for Peak detection (PK) at frequency above 1GHz.
3. The resolution bandwidth of test receiver/spectrum analyzer is 1 MHz and the video bandwidth is 10 Hz for Average detection (AV) at frequency above 1GHz.
4. All modes of operation were investigated and the worst-case emissions are reported.

#### 4.2.5 DEVIATION FROM TEST STANDARD

No deviation

#### 4.2.6 TEST SETUP

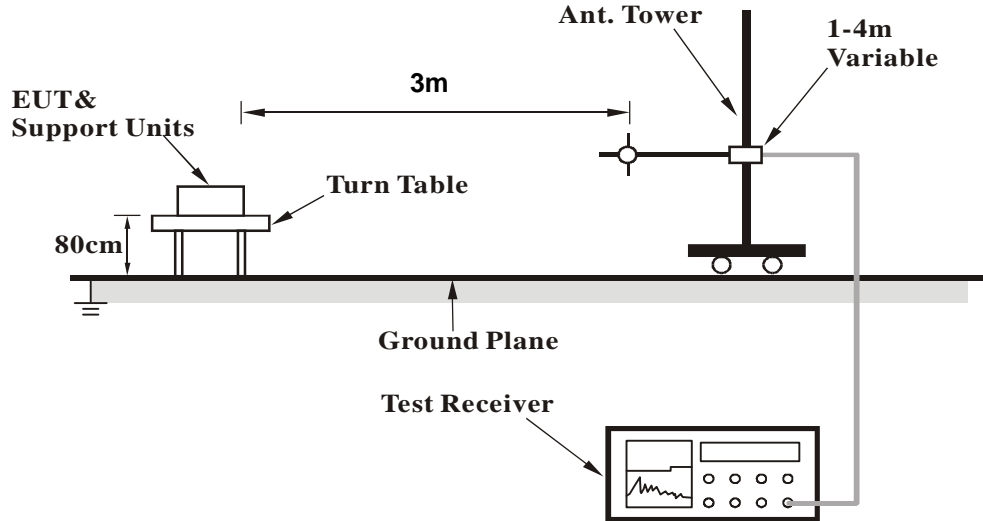

For the actual test configuration, please refer to the related item – Photographs of the Test Configuration.

#### 4.2.7 EUT OPERATING CONDITION

Same as 4.1.6



## 4.2.8 TEST RESULTS

### BELOW 1GHz WORST-CASE DATA

#### 802.11n (HT20)

<b>CHANNEL</b>	TX Channel 40	<b>DETECTOR FUNCTION</b>	Quasi-Peak (QP)
<b>FREQUENCY RANGE</b>	Below 1GHz		

#### ANTENNA POLARITY & TEST DISTANCE: HORIZONTAL AT 3 M

NO.	FREQ. (MHz)	EMISSION LEVEL (dBuV/m)	LIMIT (dBuV/m)	MARGIN (dB)	ANTENNA HEIGHT (m)	TABLE ANGLE (Degree)	RAW VALUE (dBuV)	CORRECTION FACTOR (dB/m)
1	246.00	37.2 QP	46.0	-8.8	1.25 H	24	24.08	13.12
2	599.50	33.2 QP	46.0	-12.8	1.48 H	15	10.99	22.21
3	625.03	35.7 QP	46.0	-10.3	1.53 H	254	13.18	22.54
4	750.00	33.6 QP	46.0	-12.4	1.00 H	23	9.03	24.56
5	801.00	35.1 QP	46.0	-11.0	1.00 H	230	9.42	25.63
6	875.04	43.3 QP	46.0	-2.7	1.00 H	356	16.67	26.66

#### ANTENNA POLARITY & TEST DISTANCE: VERTICAL AT 3 M

NO.	FREQ. (MHz)	EMISSION LEVEL (dBuV/m)	LIMIT (dBuV/m)	MARGIN (dB)	ANTENNA HEIGHT (m)	TABLE ANGLE (Degree)	RAW VALUE (dBuV)	CORRECTION FACTOR (dB/m)
1	43.81	35.7 QP	40.0	-4.3	1.20 V	25	21.61	14.07
2	250.03	32.2 QP	46.0	-13.8	1.54 V	24	18.87	13.30
3	600.09	35.0 QP	46.0	-11.0	1.24 V	298	12.79	22.22
4	625.00	36.3 QP	46.0	-9.7	1.00 V	47	13.75	22.54
5	800.00	34.5 QP	46.0	-11.5	1.21 V	144	8.88	25.62
6	875.02	41.1 QP	46.0	-4.9	1.00 V	245	14.46	26.66

#### REMARKS:

1. Emission level (dBuV/m) = Raw Value (dBuV) + Correction Factor (dB/m).
2. Correction Factor (dB/m) = Antenna Factor (dB/m) + Cable Factor (dB).
3. The other emission levels were very low against the limit.
4. Margin value = Emission level – Limit value.



A D T

ABOVE 1GHz DATA

802.11a

<b>CHANNEL</b>	TX Channel 36	<b>DETECTOR FUNCTION</b>	Peak (PK)
<b>FREQUENCY RANGE</b>	1GHz ~ 40GHz		Average (AV)

**ANTENNA POLARITY & TEST DISTANCE: HORIZONTAL AT 3 M**

NO.	FREQ. (MHz)	EMISSION LEVEL (dBuV/m)	LIMIT (dBuV/m)	MARGIN (dB)	ANTENNA HEIGHT (m)	TABLE ANGLE (Degree)	RAW VALUE (dBuV)	CORRECTION FACTOR (dB/m)
1	5150.00	57.6 PK	74.0	-16.4	1.22 H	104	15.62	41.98
2	5150.00	47.7 AV	54.0	-6.3	1.22 H	104	5.72	41.98
3	*5180.00	105.6 PK			1.22 H	104	63.53	42.07
4	*5180.00	95.1 AV			1.22 H	104	53.03	42.07
5	#10360.00	55.1 PK	68.3	-13.2	1.27 H	56	6.31	48.79
6	15540.00	62.1 PK	74.0	-11.9	1.36 H	298	7.73	54.37
7	15540.00	50.7 AV	54.0	-3.3	1.36 H	298	-3.67	54.37

**ANTENNA POLARITY & TEST DISTANCE: VERTICAL AT 3 M**

NO.	FREQ. (MHz)	EMISSION LEVEL (dBuV/m)	LIMIT (dBuV/m)	MARGIN (dB)	ANTENNA HEIGHT (m)	TABLE ANGLE (Degree)	RAW VALUE (dBuV)	CORRECTION FACTOR (dB/m)
1	5150.00	57.6 PK	74.0	-16.4	1.09 V	171	15.62	41.98
2	5150.00	46.6 AV	54.0	-7.4	1.09 V	171	4.62	41.98
3	*5180.00	101.2 PK			1.09 V	171	59.13	42.07
4	*5180.00	91.8 AV			1.09 V	171	49.73	42.07
5	#10360.00	55.3 PK	68.3	-13.0	1.36 V	36	6.51	48.79
6	15540.00	62.9 PK	74.0	-11.1	1.24 V	172	8.53	54.37
7	15540.00	50.7 AV	54.0	-3.3	1.24 V	172	-3.67	54.37

**REMARKS:**

1. Emission level (dBuV/m) = Raw Value (dBuV) + Correction Factor (dB/m).
2. Correction Factor (dB/m) = Antenna Factor (dB/m) + Cable Factor (dB).
3. The other emission levels were very low against the limit.
4. Margin value = Emission level – Limit value.
5. " \* ": Fundamental frequency.
6. " # ": The radiated frequency is out of the restricted band.



A D T

<b>CHANNEL</b>	TX Channel 40	<b>DETECTOR FUNCTION</b>	Peak (PK)
<b>FREQUENCY RANGE</b>	1GHz ~ 40GHz		Average (AV)

**ANTENNA POLARITY & TEST DISTANCE: HORIZONTAL AT 3 M**

NO.	FREQ. (MHz)	EMISSION LEVEL (dBuV/m)	LIMIT (dBuV/m)	MARGIN (dB)	ANTENNA HEIGHT (m)	TABLE ANGLE (Degree)	RAW VALUE (dBuV)	CORRECTION FACTOR (dB/m)
1	*5200.00	104.8 PK			1.22 H	103	62.67	42.13
2	*5200.00	95.2 AV			1.22 H	103	53.07	42.13
3	#10400.00	55.3 PK	68.3	-13.0	1.21 H	51	6.83	48.47
4	15600.00	61.7 PK	74.0	-12.3	1.41 H	294	7.32	54.38
5	15600.00	50.7 AV	54.0	-3.3	1.41 H	294	-3.68	54.38

**ANTENNA POLARITY & TEST DISTANCE: VERTICAL AT 3 M**

NO.	FREQ. (MHz)	EMISSION LEVEL (dBuV/m)	LIMIT (dBuV/m)	MARGIN (dB)	ANTENNA HEIGHT (m)	TABLE ANGLE (Degree)	RAW VALUE (dBuV)	CORRECTION FACTOR (dB/m)
1	*5200.00	101.4 PK			1.07 V	162	59.27	42.13
2	*5200.00	91.9 AV			1.07 V	162	49.77	42.13
3	#10400.00	54.4 PK	68.3	-13.9	1.35 V	40	5.93	48.47
4	15600.00	63.0 PK	74.0	-11.0	1.24 V	181	8.62	54.38
5	15600.00	50.6 AV	54.0	-3.4	1.24 V	181	-3.78	54.38

**REMARKS:**

1. Emission level (dBuV/m) = Raw Value (dBuV) + Correction Factor (dB/m).
2. Correction Factor (dB/m) = Antenna Factor (dB/m) + Cable Factor (dB).
3. The other emission levels were very low against the limit.
4. Margin value = Emission level – Limit value.
5. " \* ": Fundamental frequency.
6. " # ": The radiated frequency is out of the restricted band.





A D T

<b>CHANNEL</b>	TX Channel 48	<b>DETECTOR FUNCTION</b>	Peak (PK)
<b>FREQUENCY RANGE</b>	1GHz ~ 40GHz		Average (AV)

**ANTENNA POLARITY & TEST DISTANCE: HORIZONTAL AT 3 M**

NO.	FREQ. (MHz)	EMISSION LEVEL (dBuV/m)	LIMIT (dBuV/m)	MARGIN (dB)	ANTENNA HEIGHT (m)	TABLE ANGLE (Degree)	RAW VALUE (dBuV)	CORRECTION FACTOR (dB/m)
1	*5240.00	105.6 PK			1.21 H	103	63.42	42.18
2	*5240.00	95.7 AV			1.21 H	103	53.52	42.18
3	5350.00	58.9 PK	74.0	-15.1	1.21 H	103	16.62	42.28
4	5350.00	47.8 AV	54.0	-6.2	1.21 H	103	5.52	42.28
5	#10480.00	54.6 PK	68.3	-13.7	1.29 H	50	5.67	48.93
6	15720.00	61.1 PK	74.0	-12.9	1.38 H	299	7.17	53.93
7	15720.00	49.8 AV	54.0	-4.2	1.38 H	299	-4.13	53.93

**ANTENNA POLARITY & TEST DISTANCE: VERTICAL AT 3 M**

NO.	FREQ. (MHz)	EMISSION LEVEL (dBuV/m)	LIMIT (dBuV/m)	MARGIN (dB)	ANTENNA HEIGHT (m)	TABLE ANGLE (Degree)	RAW VALUE (dBuV)	CORRECTION FACTOR (dB/m)
1	*5240.00	101.9 PK			1.08 V	160	59.72	42.18
2	*5240.00	92.3 AV			1.08 V	160	50.12	42.18
3	5350.00	58.2 PK	74.0	-15.8	1.08 V	160	15.92	42.28
4	5350.00	46.7 AV	54.0	-7.3	1.08 V	160	4.42	42.28
5	#10480.00	55.4 PK	68.3	-12.9	1.30 V	67	6.47	48.93
6	15720.00	62.9 PK	74.0	-11.1	1.20 V	161	8.97	53.93
7	15720.00	51.0 AV	54.0	-3.0	1.20 V	161	-2.93	53.93

**REMARKS:**

1. Emission level (dBuV/m) = Raw Value (dBuV) + Correction Factor (dB/m).
2. Correction Factor (dB/m) = Antenna Factor (dB/m) + Cable Factor (dB).
3. The other emission levels were very low against the limit.
4. Margin value = Emission level – Limit value.
5. " \* ": Fundamental frequency.
6. " # ": The radiated frequency is out of the restricted band.

802.11n (HT20)

<b>CHANNEL</b>	TX Channel 36	<b>DETECTOR FUNCTION</b>	Peak (PK)
<b>FREQUENCY RANGE</b>	1GHz ~ 40GHz		Average (AV)

ANTENNA POLARITY & TEST DISTANCE: HORIZONTAL AT 3 M								
NO.	FREQ. (MHz)	EMISSION LEVEL (dBuV/m)	LIMIT (dBuV/m)	MARGIN (dB)	ANTENNA HEIGHT (m)	TABLE ANGLE (Degree)	RAW VALUE (dBuV)	CORRECTION FACTOR (dB/m)
1	5100.00	58.9 PK	74.0	-15.1	1.19 H	97	17.07	41.83
2	5100.00	47.9 AV	54.0	-6.1	1.19 H	97	6.07	41.83
3	*5180.00	106.3 PK			1.19 H	97	64.23	42.07
4	*5180.00	95.9 AV			1.19 H	97	53.83	42.07
5	#10360.00	54.3 PK	68.3	-14.0	1.25 H	62	5.51	48.79
6	15540.00	61.6 PK	74.0	-12.4	1.36 H	284	7.23	54.37
7	15540.00	50.3 AV	54.0	-3.7	1.36 H	284	-4.07	54.37

ANTENNA POLARITY & TEST DISTANCE: VERTICAL AT 3 M								
NO.	FREQ. (MHz)	EMISSION LEVEL (dBuV/m)	LIMIT (dBuV/m)	MARGIN (dB)	ANTENNA HEIGHT (m)	TABLE ANGLE (Degree)	RAW VALUE (dBuV)	CORRECTION FACTOR (dB/m)
1	5150.00	57.7 PK	74.0	-16.3	1.04 V	105	15.72	41.98
2	5150.00	47.4 AV	54.0	-6.6	1.04 V	105	5.42	41.98
3	*5180.00	102.8 PK			1.04 V	105	60.73	42.07
4	*5180.00	93.7 AV			1.04 V	105	51.63	42.07
5	#10360.00	55.1 PK	68.3	-13.2	1.33 V	51	6.31	48.79
6	15540.00	62.3 PK	74.0	-11.7	1.16 V	142	7.93	54.37
7	15540.00	50.4 AV	54.0	-3.6	1.16 V	142	-3.97	54.37

**REMARKS:**

1. Emission level (dBuV/m) = Raw Value (dBuV) + Correction Factor (dB/m).
2. Correction Factor (dB/m) = Antenna Factor (dB/m) + Cable Factor (dB).
3. The other emission levels were very low against the limit.
4. Margin value = Emission level – Limit value.
5. " \* ": Fundamental frequency.
6. " # ": The radiated frequency is out of the restricted band.



A D T

<b>CHANNEL</b>	TX Channel 40	<b>DETECTOR FUNCTION</b>	Peak (PK)
<b>FREQUENCY RANGE</b>	1GHz ~ 40GHz		Average (AV)

**ANTENNA POLARITY & TEST DISTANCE: HORIZONTAL AT 3 M**

NO.	FREQ. (MHz)	EMISSION LEVEL (dBuV/m)	LIMIT (dBuV/m)	MARGIN (dB)	ANTENNA HEIGHT (m)	TABLE ANGLE (Degree)	RAW VALUE (dBuV)	CORRECTION FACTOR (dB/m)
1	*5200.00	106.7 PK			1.21 H	103	64.57	42.13
2	*5200.00	95.9 AV			1.21 H	103	53.77	42.13
3	#10400.00	54.6 PK	68.3	-13.7	1.21 H	57	6.13	48.47
4	15600.00	62.5 PK	74.0	-11.5	1.00 H	110	8.12	54.38
5	15600.00	50.6 AV	54.0	-3.4	1.00 H	110	-3.78	54.38

**ANTENNA POLARITY & TEST DISTANCE: VERTICAL AT 3 M**

NO.	FREQ. (MHz)	EMISSION LEVEL (dBuV/m)	LIMIT (dBuV/m)	MARGIN (dB)	ANTENNA HEIGHT (m)	TABLE ANGLE (Degree)	RAW VALUE (dBuV)	CORRECTION FACTOR (dB/m)
1	*5200.00	104.5 PK			1.03 V	104	62.37	42.13
2	*5200.00	94.2 AV			1.03 V	104	52.07	42.13
3	#10400.00	54.9 PK	68.3	-13.4	1.33 V	62	6.43	48.47
4	15600.00	62.8 PK	74.0	-11.2	1.25 V	172	8.42	54.38
5	15600.00	50.7 AV	54.0	-3.3	1.25 V	172	-3.68	54.38

**REMARKS:**

1. Emission level (dBuV/m) = Raw Value (dBuV) + Correction Factor (dB/m).
2. Correction Factor (dB/m) = Antenna Factor (dB/m) + Cable Factor (dB).
3. The other emission levels were very low against the limit.
4. Margin value = Emission level – Limit value.
5. " \* ": Fundamental frequency.
6. " # ": The radiated frequency is out of the restricted band.



A D T

<b>CHANNEL</b>	TX Channel 48	<b>DETECTOR FUNCTION</b>	Peak (PK)
<b>FREQUENCY RANGE</b>	1GHz ~ 40GHz		Average (AV)

**ANTENNA POLARITY & TEST DISTANCE: HORIZONTAL AT 3 M**

NO.	FREQ. (MHz)	EMISSION LEVEL (dBuV/m)	LIMIT (dBuV/m)	MARGIN (dB)	ANTENNA HEIGHT (m)	TABLE ANGLE (Degree)	RAW VALUE (dBuV)	CORRECTION FACTOR (dB/m)
1	*5240.00	106.1 PK			1.21 H	103	63.92	42.18
2	*5240.00	96.6 AV			1.21 H	103	54.42	42.18
3	5350.00	58.6 PK	74.0	-15.4	1.21 H	103	16.32	42.28
4	5350.00	48.5 AV	54.0	-5.5	1.21 H	103	6.22	42.28
5	#10480.00	53.9 PK	68.3	-14.4	1.26 H	70	4.97	48.93
6	15720.00	61.6 PK	74.0	-12.4	1.35 H	272	7.67	53.93
7	15720.00	50.2 AV	54.0	-3.8	1.35 H	272	-3.73	53.93

**ANTENNA POLARITY & TEST DISTANCE: VERTICAL AT 3 M**

NO.	FREQ. (MHz)	EMISSION LEVEL (dBuV/m)	LIMIT (dBuV/m)	MARGIN (dB)	ANTENNA HEIGHT (m)	TABLE ANGLE (Degree)	RAW VALUE (dBuV)	CORRECTION FACTOR (dB/m)
1	*5240.00	105.3 PK			1.01 V	104	63.12	42.18
2	*5240.00	95.8 AV			1.01 V	104	53.62	42.18
3	5350.00	58.3 PK	74.0	-15.7	1.01 V	104	16.02	42.28
4	5350.00	47.5 AV	54.0	-6.5	1.01 V	104	5.22	42.28
5	#10480.00	54.6 PK	68.3	-13.7	1.33 V	57	5.67	48.93
6	15720.00	62.4 PK	74.0	-11.6	1.21 V	157	8.47	53.93
7	15720.00	50.3 AV	54.0	-3.7	1.21 V	157	-3.63	53.93

**REMARKS:**

1. Emission level (dBuV/m) = Raw Value (dBuV) + Correction Factor (dB/m).
2. Correction Factor (dB/m) = Antenna Factor (dB/m) + Cable Factor (dB).
3. The other emission levels were very low against the limit.
4. Margin value = Emission level – Limit value.
5. " \* ": Fundamental frequency.
6. " # ": The radiated frequency is out of the restricted band.

802.11n (HT40)

<b>CHANNEL</b>	TX Channel 38	<b>DETECTOR FUNCTION</b>	Peak (PK)
<b>FREQUENCY RANGE</b>	1GHz ~ 40GHz		Average (AV)

**ANTENNA POLARITY & TEST DISTANCE: HORIZONTAL AT 3 M**

NO.	FREQ. (MHz)	EMISSION LEVEL (dBuV/m)	LIMIT (dBuV/m)	MARGIN (dB)	ANTENNA HEIGHT (m)	TABLE ANGLE (Degree)	RAW VALUE (dBuV)	CORRECTION FACTOR (dB/m)
1	5150.00	66.8 PK	74.0	-7.2	1.20 H	93	24.82	41.98
2	5150.00	52.6 AV	54.0	-1.4	1.20 H	93	10.62	41.98
3	*5190.00	109.4 PK			1.20 H	93	67.30	42.10
4	*5190.00	98.5 AV			1.20 H	93	56.40	42.10
5	5350.00	61.1 PK	74.0	-12.9	1.18 H	107	18.82	42.28
6	5350.00	52.9 AV	54.0	-1.1	1.18 H	107	10.62	42.28
7	#10380.00	54.6 PK	68.3	-13.7	1.25 H	63	5.97	48.63
8	15570.00	62.3 PK	74.0	-11.7	1.33 H	261	7.92	54.38
9	15570.00	50.6 AV	54.0	-3.4	1.33 H	261	-3.78	54.38

**ANTENNA POLARITY & TEST DISTANCE: VERTICAL AT 3 M**

NO.	FREQ. (MHz)	EMISSION LEVEL (dBuV/m)	LIMIT (dBuV/m)	MARGIN (dB)	ANTENNA HEIGHT (m)	TABLE ANGLE (Degree)	RAW VALUE (dBuV)	CORRECTION FACTOR (dB/m)
1	5150.00	62.3 PK	74.0	-11.7	1.02 V	104	20.32	41.98
2	5150.00	51.1 AV	54.0	-2.9	1.02 V	104	9.12	41.98
3	*5190.00	106.8 PK			1.02 V	104	64.70	42.10
4	*5190.00	96.3 AV			1.02 V	104	54.20	42.10
5	#10380.00	54.9 PK	68.3	-13.4	1.36 V	58	6.27	48.63
6	15570.00	62.7 PK	74.0	-11.3	1.22 V	151	8.32	54.38
7	15570.00	50.1 AV	54.0	-3.9	1.22 V	151	-4.28	54.38

**REMARKS:**

1. Emission level (dBuV/m) = Raw Value (dBuV) + Correction Factor (dB/m).
2. Correction Factor (dB/m) = Antenna Factor (dB/m) + Cable Factor (dB).
3. The other emission levels were very low against the limit.
4. Margin value = Emission level – Limit value.
5. " \* ": Fundamental frequency.
6. " # ": The radiated frequency is out of the restricted band.



A D T

<b>CHANNEL</b>	TX Channel 46	<b>DETECTOR FUNCTION</b>	Peak (PK)
<b>FREQUENCY RANGE</b>	1GHz ~ 40GHz		Average (AV)

**ANTENNA POLARITY & TEST DISTANCE: HORIZONTAL AT 3 M**

NO.	FREQ. (MHz)	EMISSION LEVEL (dBuV/m)	LIMIT (dBuV/m)	MARGIN (dB)	ANTENNA HEIGHT (m)	TABLE ANGLE (Degree)	RAW VALUE (dBuV)	CORRECTION FACTOR (dB/m)
1	*5230.00	105.6 PK			1.19 H	94	63.43	42.17
2	*5230.00	95.1 AV			1.19 H	94	52.93	42.17
3	5350.00	58.8 PK	74.0	-15.2	1.19 H	94	16.52	42.28
4	5350.00	48.1 AV	54.0	-5.9	1.19 H	94	5.82	42.28
5	#10460.00	54.3 PK	68.3	-14.0	1.26 H	65	5.49	48.81
6	15690.00	61.5 PK	74.0	-12.5	1.33 H	265	7.59	53.91
7	15690.00	50.9 AV	54.0	-3.1	1.33 H	265	-3.01	53.91

**ANTENNA POLARITY & TEST DISTANCE: VERTICAL AT 3 M**

NO.	FREQ. (MHz)	EMISSION LEVEL (dBuV/m)	LIMIT (dBuV/m)	MARGIN (dB)	ANTENNA HEIGHT (m)	TABLE ANGLE (Degree)	RAW VALUE (dBuV)	CORRECTION FACTOR (dB/m)
1	*5230.00	103.6 PK			1.02 V	105	61.43	42.17
2	*5230.00	93.3 AV			1.02 V	105	51.13	42.17
3	5350.00	57.6 PK	74.0	-16.4	1.02 V	105	15.32	42.28
4	5350.00	47.1 AV	54.0	-6.9	1.02 V	105	4.82	42.28
5	#10460.00	55.1 PK	68.3	-13.2	1.31 V	53	6.29	48.81
6	15690.00	62.6 PK	74.0	-11.4	1.21 V	154	8.69	53.91
7	15690.00	50.7 AV	54.0	-3.3	1.21 V	154	-3.21	53.91

**REMARKS:**

1. Emission level (dBuV/m) = Raw Value (dBuV) + Correction Factor (dB/m).
2. Correction Factor (dB/m) = Antenna Factor (dB/m) + Cable Factor (dB).
3. The other emission levels were very low against the limit.
4. Margin value = Emission level – Limit value.
5. " \* ": Fundamental frequency.
6. " # ": The radiated frequency is out of the restricted band.



802.11ac VHT80

<b>CHANNEL</b>	TX Channel 42	<b>DETECTOR FUNCTION</b>	Peak (PK)
<b>FREQUENCY RANGE</b>	1GHz ~ 40GHz		Average (AV)

**ANTENNA POLARITY & TEST DISTANCE: HORIZONTAL AT 3 M**

NO.	FREQ. (MHz)	EMISSION LEVEL (dBuV/m)	LIMIT (dBuV/m)	MARGIN (dB)	ANTENNA HEIGHT (m)	TABLE ANGLE (Degree)	RAW VALUE (dBuV)	CORRECTION FACTOR (dB/m)
1	5150.00	64.9 PK	74.0	-9.1	1.19 H	92	22.92	41.98
2	5150.00	53.4 AV	54.0	-0.6	1.19 H	92	11.42	41.98
3	*5210.00	106.1 PK			1.19 H	92	63.96	42.14
4	*5210.00	93.6 AV			1.19 H	92	51.46	42.14
5	5350.00	59.2 PK	74.0	-14.8	1.19 H	92	16.92	42.28
6	5350.00	47.7 AV	54.0	-6.3	1.19 H	92	5.42	42.28
7	#10420.00	54.6 PK	68.3	-13.7	1.24 H	58	6.02	48.58
9	15630.00	61.5 PK	74.0	-12.5	1.31 H	261	7.28	54.22
10	15630.00	50.7 AV	54.0	-3.3	1.31 H	261	-3.52	54.22

**ANTENNA POLARITY & TEST DISTANCE: VERTICAL AT 3 M**

NO.	FREQ. (MHz)	EMISSION LEVEL (dBuV/m)	LIMIT (dBuV/m)	MARGIN (dB)	ANTENNA HEIGHT (m)	TABLE ANGLE (Degree)	RAW VALUE (dBuV)	CORRECTION FACTOR (dB/m)
1	5150.00	63.9 PK	74.0	-10.1	1.29 V	104	21.92	41.98
2	5150.00	52.5 AV	54.0	-1.5	1.29 V	104	10.52	41.98
3	*5210.00	103.6 PK			1.02 V	104	61.46	42.14
4	*5210.00	91.5 AV			1.02 V	104	49.36	42.14
5	5350.00	58.9 PK	74.0	-15.1	1.29 V	104	16.62	42.28
6	5350.00	46.8 AV	54.0	-7.2	1.29 V	104	4.52	42.28
7	#10420.00	55.3 PK	68.3	-13.0	1.30 V	54	6.72	48.58
9	15630.00	62.4 PK	74.0	-11.6	1.22 V	151	8.18	54.22
10	15630.00	50.3 AV	54.0	-3.7	1.22 V	151	-3.92	54.22

**REMARKS:**

1. Emission level (dBuV/m) = Raw Value (dBuV) + Correction Factor (dB/m).
2. Correction Factor (dB/m) = Antenna Factor (dB/m) + Cable Factor (dB).
3. The other emission levels were very low against the limit.
4. Margin value = Emission level – Limit value.
5. " \* ": Fundamental frequency.
6. " # ": The radiated frequency is out of the restricted band.



A D T

### 4.3 TRANSMIT POWER MEASUREMENT

#### 4.3.1 LIMITS OF TRANSMIT POWER MEASUREMENT

Frequency Band	Limit
5.15 – 5.25GHz	The lesser of 50mW (17dBm) or 4dBm + 10logB
5.25 – 5.35GHz	The lesser of 250mW (24dBm) or 11dBm + 10logB
5.47 – 5.725GHz	The lesser of 250mW (24dBm) or 11dBm + 10logB
5.725 – 5.825GHz	The lesser of 1W (30dBm) or 17dBm + 10logB

**NOTE:** Where B is the 26dB emission bandwidth in MHz.

#### 4.3.2 TEST INSTRUMENTS

DESCRIPTION & MANUFACTURER	MODEL NO.	SERIAL NO.	CALIBRATED DATE	CALIBRATED UNTIL
R&S Spectrum Analyzer	FSP40	100036	Dec. 14, 2011	Dec. 13, 2012

**Note:**

1. The calibration interval of the above test instruments is 12 months and the calibrations are traceable to NML/ROC and NIST/USA.
2. Tested date : July 04, 2012

#### 4.3.3 TEST PROCEDURE

##### FOR POWER OUTPUT MEASUREMENT

Follow FCC KDB 789033 UNII test procedure:

Method SA-1

- 1) Set span to encompass the entire emission bandwidth (EBW) of the signal.
- 2) Set RBW =1MHz.
- 3) Set the VBW  $\geq 3 \times$  RBW.
- 4) Number of points in sweep  $\geq 2$  Span / RBW.
- 5) Sweep time = auto.
- 6) Set trigger to free run (duty cycle  $\geq 98$  percent) ; Set video trigger (duty cycle  $< 98$  percent)
- 6) Detector = RMS.
- 7) Trace average at least 100 traces in power averaging mode
- 8) Compute power by integrating the spectrum across the 26 dB EBW of the signal.



#### FOR 26dB OCCUPIED BANDWIDTH

- 1) Set RBW = approximately 1% of the emission bandwidth.
- 2) Set the VBW > RBW.
- 3) Detector = Peak.
- 4) Trace mode = max hold.
- 5) Measure the maximum width of the emission that is 26 dB down from the peak of the emission. Compare this with the RBW setting of the analyzer. Readjust RBW and repeat measurement as needed until the RBW/EBW ratio is approximately 1%.

#### 4.3.4 DEVIATION FROM TEST STANDARD

No deviation

#### 4.3.5 TEST SETUP

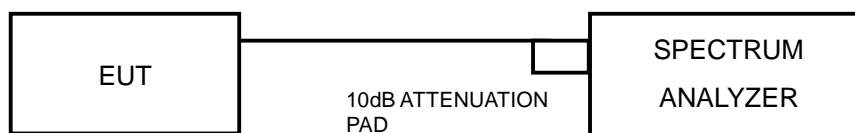

#### 4.3.6 EUT OPERATING CONDITIONS

The software provided by client to enable the EUT under transmission condition continuously at specific channel frequencies individually.

### 4.3.7 TEST RESULTS

#### POWER OUTPUT:

##### 802.11a

CHAN.	CHAN. FREQ. (MHz)	AVERAGE POWER (dBm)			TOTAL POWER (mW)	TOTAL POWER (dBm)	POWER LIMIT (dBm)	PASS / FAIL
		CHAIN 0	CHAIN 1	CHAIN 2				
36	5180	5.50	6.64	7.02	13.196	11.20	13.76	PASS
40	5200	5.39	6.61	6.74	12.761	11.06	13.76	PASS
48	5240	5.62	6.43	6.75	12.775	11.06	13.76	PASS

**Note:** Directional gain =  $10 \log[(10^{G1(\text{Chain}0)/20} + 10^{G2(\text{Chain}1)/20} + 10^{G3(\text{Chain}2)/20})^2 / 3]$

Effective Legacy Gain (dBi) = 9.24

The effective legacy gain is 9.24dBi, therefore the limit needs to reduce.

##### 802.11n (HT20)

CHAN.	CHAN. FREQ. (MHz)	AVERAGE POWER (dBm)			TOTAL POWER (mW)	TOTAL POWER (dBm)	POWER LIMIT (dBm)	PASS / FAIL
		CHAIN 0	CHAIN 1	CHAIN 2				
36	5180	9.10	10.08	10.16	28.689	14.58	17	PASS
40	5200	8.82	10.24	10.32	28.954	14.62	17	PASS
48	5240	9.06	10.16	9.97	28.360	14.53	17	PASS

##### 802.11n (HT40)

CHAN.	CHAN. FREQ. (MHz)	AVERAGE POWER (dBm)			TOTAL POWER (mW)	TOTAL POWER (dBm)	POWER LIMIT (dBm)	PASS / FAIL
		CHAIN 0	CHAIN 1	CHAIN 2				
38	5190	11.24	11.98	12.12	45.374	16.57	17	PASS
46	5230	11.08	12.27	12.47	47.349	16.75	17	PASS

##### 802.11ac (VHT80)

CHAN.	CHAN. FREQ. (MHz)	AVERAGE POWER (dBm)			TOTAL POWER (mW)	TOTAL POWER (dBm)	POWER LIMIT (dBm)	PASS / FAIL
		CHAIN 0	CHAIN 1	CHAIN 2				
42	5210	11.49	12.23	12.47	48.464	16.85	17	PASS



A D T

## 26dB BANDWIDTH:

### 802.11a

CHANNEL	CHANNEL FREQUENCY (MHz)	26dBc BANDWIDTH (MHz)		
		CHAIN 0	CHAIN 1	CHAIN 2
36	5180	20.62	20.51	20.28
40	5200	20.62	20.42	20.54
48	5240	20.60	20.53	20.34

### 802.11n (HT20)

CHANNEL	CHANNEL FREQUENCY (MHz)	26dBc BANDWIDTH (MHz)		
		CHAIN 0	CHAIN 1	CHAIN 2
36	5180	20.86	20.65	20.64
40	5200	20.85	20.67	20.65
48	5240	20.80	20.62	20.75

### 802.11n (HT40)

CHANNEL	CHANNEL FREQUENCY (MHz)	26dBc BANDWIDTH (MHz)		
		CHAIN 0	CHAIN 1	CHAIN 2
38	5190	41.65	41.15	41.19
46	5230	41.68	41.23	41.17

### 802.11ac (VHT80)

CHANNEL	CHANNEL FREQUENCY (MHz)	26dBc BANDWIDTH (MHz)		
		CHAIN 0	CHAIN 1	CHAIN 2
42	5210	82.98	82.51	82.47



A D T

#### 4.4 PEAK POWER SPECTRAL DENSITY MEASUREMENT

##### 4.4.1 LIMITS OF PEAK POWER SPECTRAL DENSITY MEASUREMENT

Frequency Band	Limit
5.15 ~ 5.25GHz	4dBm
5.25 ~ 5.35GHz	11dBm
5.47 ~ 5.725GHz	11dBm
5.725 ~ 5.825GHz	17dBm

##### 4.4.2 TEST INSTRUMENTS

DESCRIPTION & MANUFACTURER	MODEL NO.	SERIAL NO.	CALIBRATED DATE	CALIBRATED UNTIL
R&S Spectrum Analyzer	FSP40	100036	Dec. 14, 2011	Dec. 13, 2012

**Note:**

1. The calibration interval of the above test instruments is 12 months and the calibrations are traceable to NML/ROC and NIST/USA.
2. Tested date : July 04, 2012

##### 4.4.3 TEST PROCEDURES

- 1) Set span to encompass the entire emission bandwidth (EBW) of the signal.
- 2) Set RBW = 1 MHz, Set VBW  $\geq$  3 MHz, Detector = RMS
- 3) Sweep time = auto, trigger set to "free run".
- 4) Trace average at least 100 traces in power averaging mode.
- 5) Record the max value

##### 4.4.4 DEVIATION FROM TEST STANDARD

No deviation



A D T

#### 4.4.5 TEST SETUP

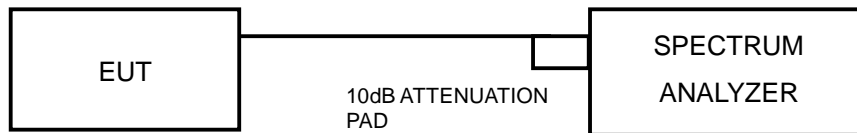

#### 4.4.6 EUT OPERATING CONDITIONS

Same as 4.3.6



### 4.4.7 TEST RESULTS

#### 802.11a

CHAN.	CHAN. FREQ. (MHz)	PSD (dBm)			TOTAL POWER DENSITY (dBm)	MAX. LIMIT (dBm)	PASS / FAIL
		CHAIN 0	CHAIN 1	CHAIN 2			
36	5180	-5.24	-3.96	-3.59	0.50	0.76	PASS
40	5200	-5.29	-3.86	-3.75	0.46	0.76	PASS
48	5240	-4.97	-4.10	-3.77	0.48	0.76	PASS

**NOTE:** Directional gain =  $10 \log[(10^{G1(\text{Chain0})/20} + 10^{G2(\text{Chain1})/20} + 10^{G3(\text{Chain2})/20})^2 / 3]$

Effective Legacy Gain (dBi) = 9.24

The effective legacy gain is 9.24dBi, therefore the limit needs to reduce.

Method 1 of power density measurement of KDB 662911 is using for calculating total power density. Total power density is summing entire spectra across corresponding frequency bins on the various outputs by computer

#### 802.11n (HT20)

CHAN.	CHAN. FREQ. (MHz)	PSD (dBm)			TOTAL POWER DENSITY (dBm)	MAX. LIMIT (dBm)	PASS / FAIL
		CHAIN 0	CHAIN 1	CHAIN 2			
36	5180	-1.66	-0.90	-0.46	3.74	4	PASS
40	5200	-1.90	-0.61	-0.30	3.86	4	PASS
48	5240	-1.69	-0.69	-0.78	3.72	4	PASS

**NOTE:** Method 1 of power density measurement of KDB 662911 is using for calculating total power density. Total power density is summing entire spectra across corresponding frequency bins on the various outputs by computer.

#### 802.11n (HT40)

CHAN.	CHAN. FREQ. (MHz)	PSD (dBm)			TOTAL POWER DENSITY (dBm)	MAX. LIMIT (dBm)	PASS / FAIL
		CHAIN 0	CHAIN 1	CHAIN 2			
38	5190	-2.59	-1.69	-1.56	2.79	4	PASS
46	5230	-2.68	-1.45	-1.14	3.04	4	PASS

**NOTE:** Method 1 of power density measurement of KDB 662911 is using for calculating total power density. Total power density is summing entire spectra across corresponding frequency bins on the various outputs by computer.



A D T

802.11ac (VHT80)

CHAN.	CHAN. FREQ. (MHz)	PSD (dBm)			TOTAL POWER DENSITY (dBm)	MAX. LIMIT (dBm)	PASS / FAIL
		CHAIN 0	CHAIN 1	CHAIN 2			
42	5210	-5.11	-4.51	-4.20	0.13	4	PASS

**NOTE:** Method 1 of power density measurement of KDB 662911 is using for calculating total power density. Total power density is summing entire spectra across corresponding frequency bins on the various outputs by computer.

## 4.5 PEAK POWER EXCURSION MEASUREMENT

### 4.5.1 LIMITS OF PEAK POWER EXCURSION MEASUREMENT

Shall not exceed 13 dB

### 4.5.2 TEST INSTRUMENTS

DESCRIPTION & MANUFACTURER	MODEL NO.	SERIAL NO.	CALIBRATED DATE	CALIBRATED UNTIL
R&S Spectrum Analyzer	FSP40	100036	Dec. 14, 2011	Dec. 13, 2012

**Note:**

1. The calibration interval of the above test instruments is 12 months and the calibrations are traceable to NML/ROC and NIST/USA.
2. Tested date : July 04, 2012

### 4.5.3 TEST PROCEDURE

- 1) Set RBW = 1 MHz, VBW  $\geq$  3 MHz, Detector = peak.
- 2) Trace mode = max-hold. Allow the sweeps to continue until the trace stabilizes.
- 3) Use the peak search function to find the peak of the spectrum.
- 4) Measure the PPSD.
- 5) Compute the ratio of the maximum of the peak-max-hold spectrum to the PPSD.

### 4.5.4 DEVIATION FROM TEST STANDARD

No deviation

### 4.5.5 TEST SETUP

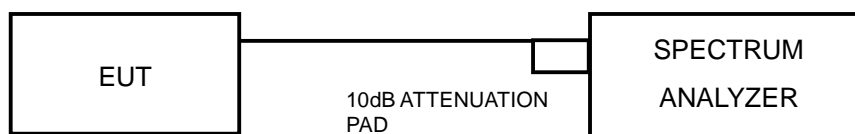

### 4.5.6 EUT OPERATING CONDITIONS

The software provided by client to enable the EUT under transmission condition continuously at specific channel frequencies individually.





A D T

## 4.5.7 TEST RESULTS

### 802.11a

CHAN.	CHAN. FREQ. (MHz)	PEAK VALUE (dBm)			PPSD (dBm)			PEAK EXCURSION (dB)			LIMIT (dB)	PASS/ FAIL
		CHAIN 0	CHAIN 1	CHAIN 2	CHAIN 0	CHAIN 1	CHAIN 2	CHAIN 0	CHAIN 1	CHAIN 2		
36	5180	4.36	6.07	6.67	-5.24	-3.96	-3.59	9.60	10.03	10.26	13	PASS
40	5200	4.51	6.15	7.10	-5.29	-3.86	-3.75	9.80	10.01	10.85	13	PASS
48	5240	4.95	5.99	6.66	-4.97	-4.10	-3.77	9.92	10.09	10.43	13	PASS



A D T

### For Chain (2): CH 40

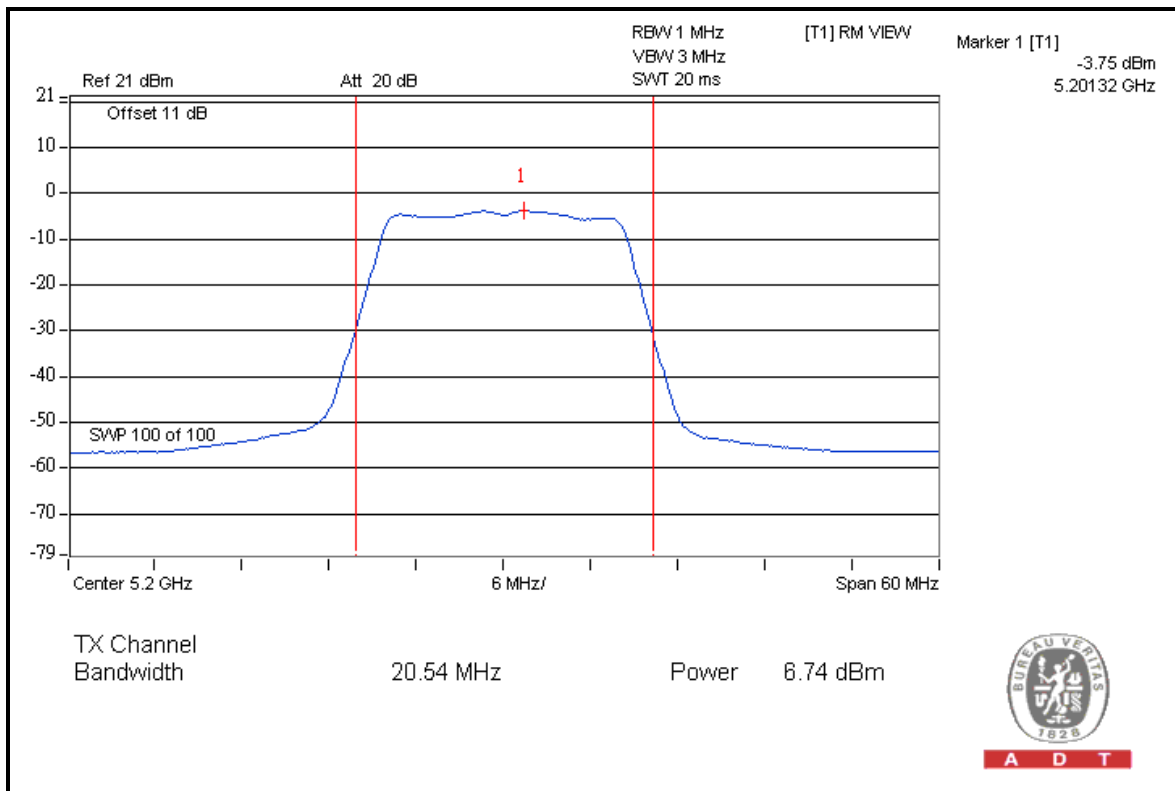
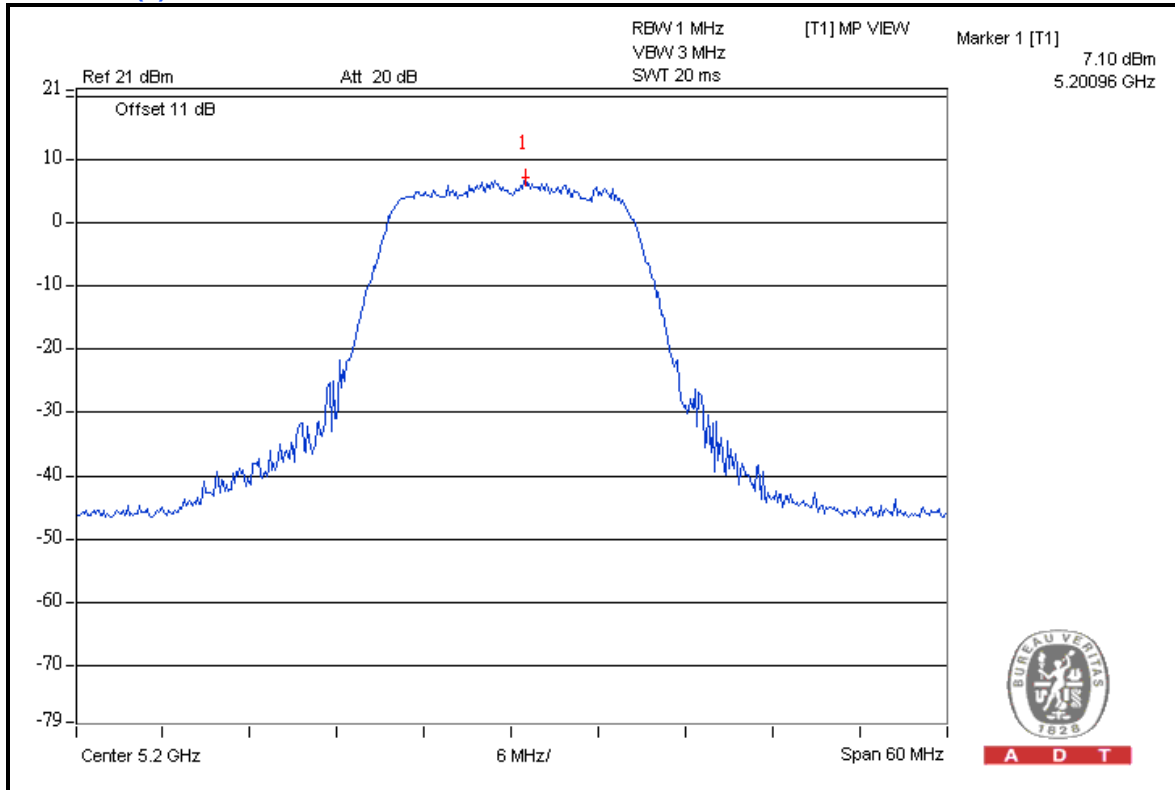



A D T

802.11n (HT20)

CHAN.	CHAN. FREQ. (MHz)	PEAK VALUE (dBm)			PPSD (dBm)			PEAK EXCURSION (dB)			LIMIT (dB)	PASS/ FAIL
		CHAIN 0	CHAIN 1	CHAIN 2	CHAIN 0	CHAIN 1	CHAIN 2	CHAIN 0	CHAIN 1	CHAIN 2		
36	5180	7.34	9.22	10.08	-1.66	-0.90	-0.46	9.00	10.12	10.54	13	PASS
40	5200	7.42	9.08	9.85	-1.90	-0.61	-0.30	9.32	9.69	10.15	13	PASS
48	5240	7.46	8.75	9.56	-1.69	-0.69	-0.78	9.15	9.44	10.34	13	PASS



A D T

### For Chain (2): CH 36

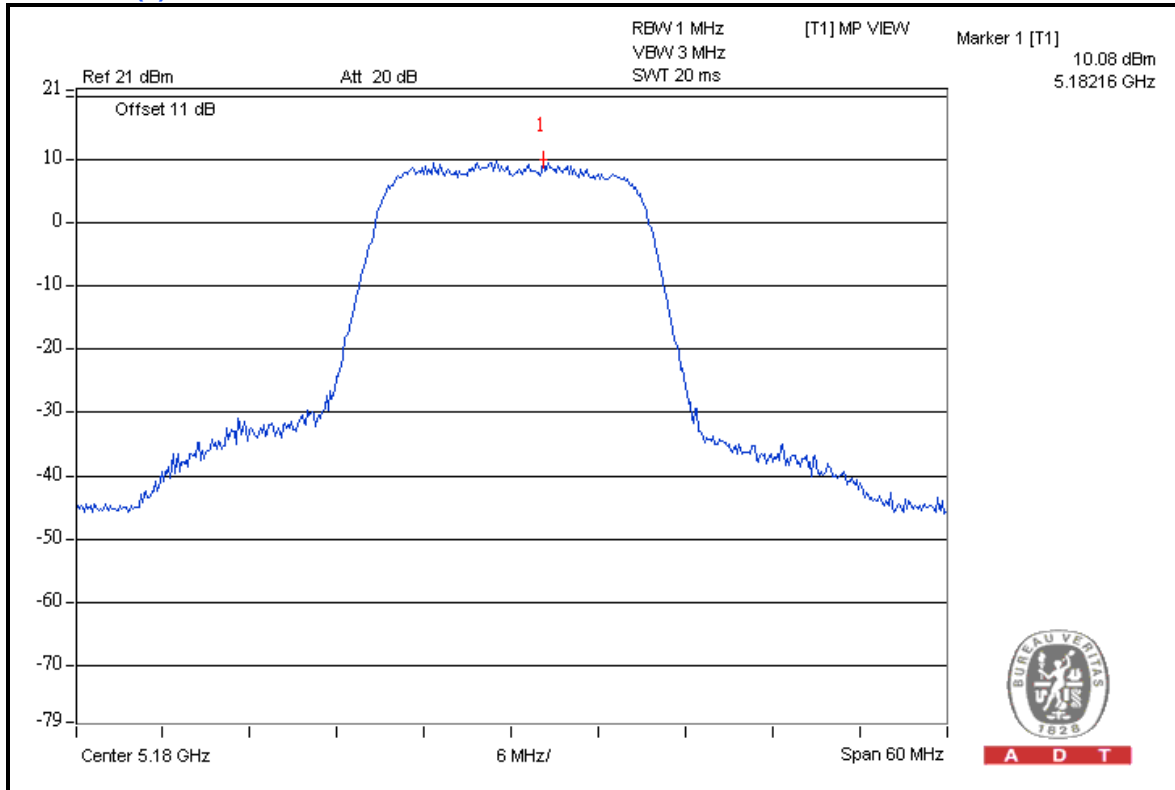

A D T

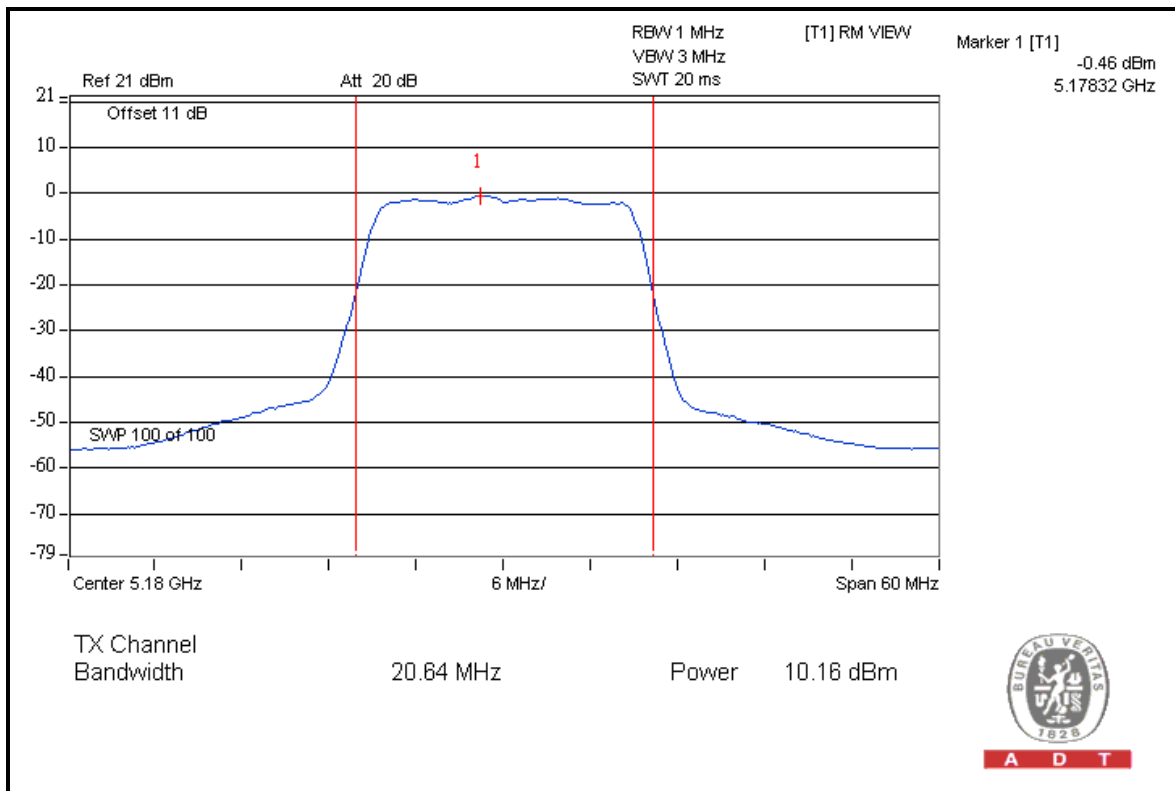

A D T



A D T

802.11n (HT40)

CHAN.	CHAN. FREQ. (MHz)	PEAK VALUE (dBm)			PPSD (dBm)			PEAK EXCURSION (dB)			LIMIT (dB)	PASS/ FAIL
		CHAIN 0	CHAIN 1	CHAIN 2	CHAIN 0	CHAIN 1	CHAIN 2	CHAIN 0	CHAIN 1	CHAIN 2		
38	5190	6.88	8.24	8.97	-2.59	-1.69	-1.56	9.47	9.93	10.53	13	PASS
46	5230	6.46	8.53	9.00	-2.68	-1.45	-1.14	9.14	9.98	10.14	13	PASS



A D T

### For Chain (2): CH 38

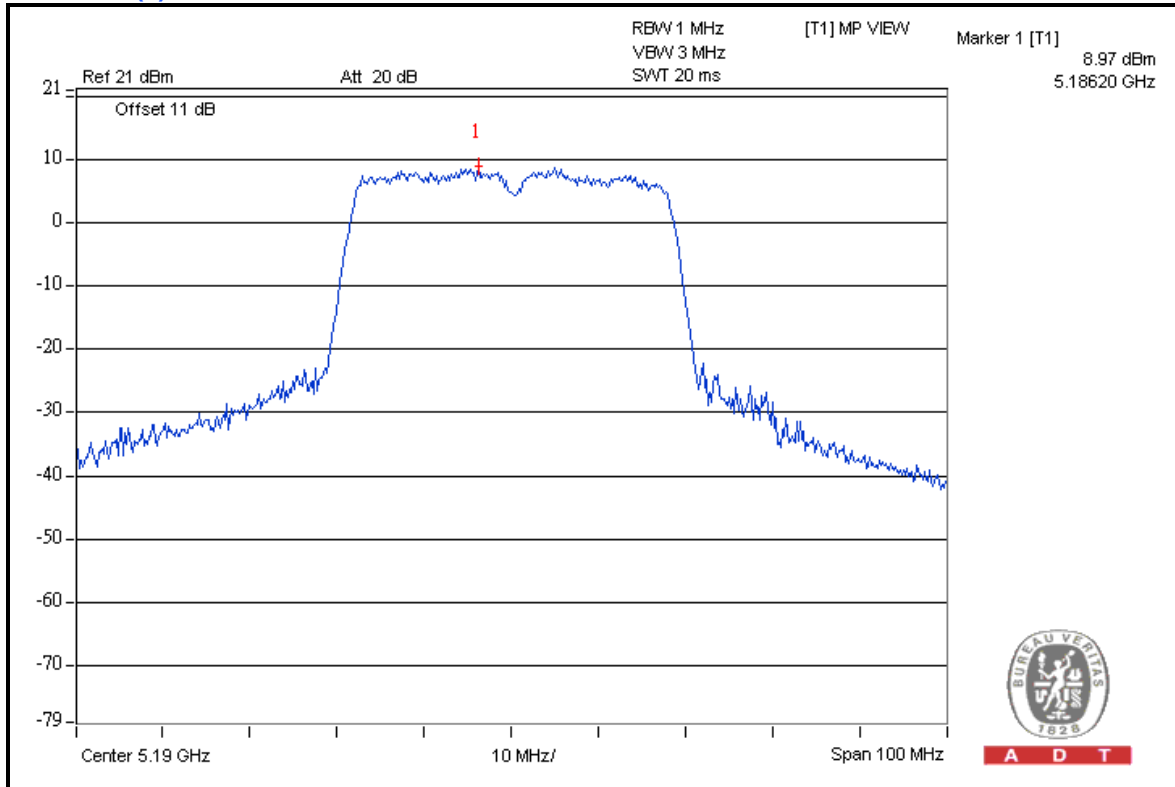

A D T

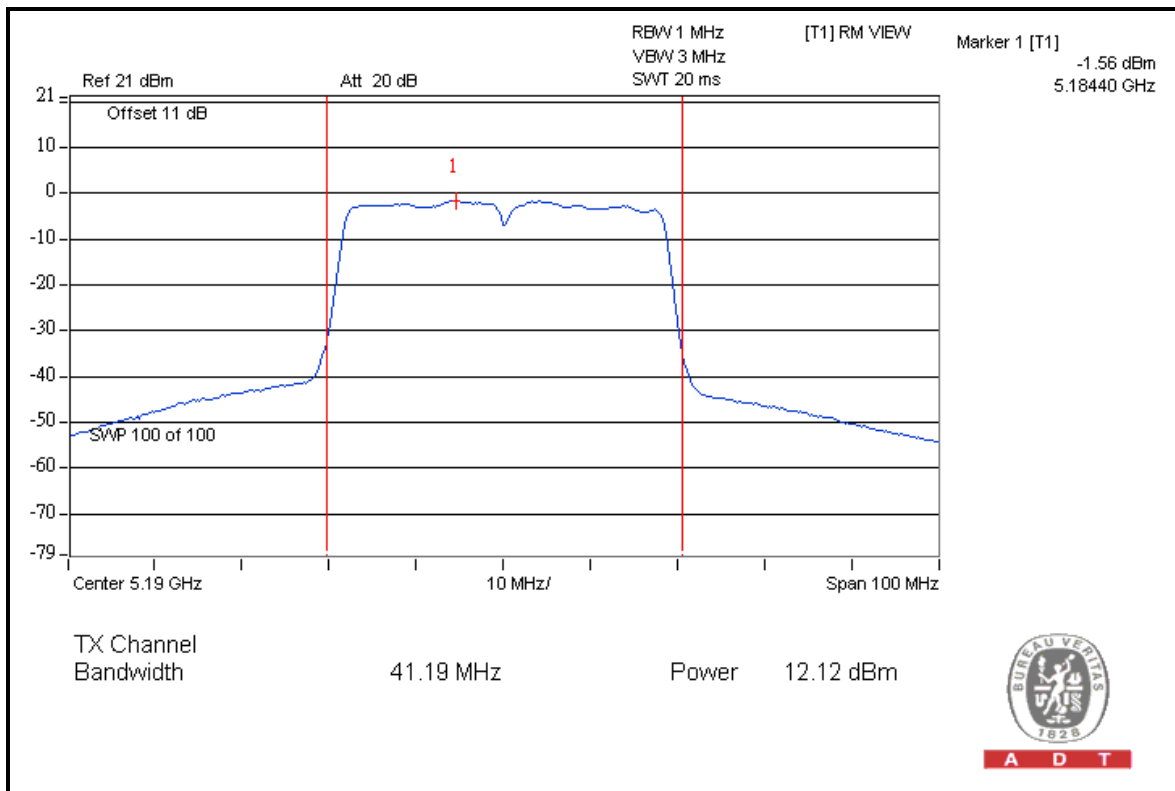

A D T



A D T

802.11ac (VHT80)

CHAN.	CHAN. FREQ. (MHz)	PEAK VALUE (dBm)			PPSD (dBm)			PEAK EXCURSION (dB)			LIMIT (dB)	PASS/ FAIL
		CHAIN 0	CHAIN 1	CHAIN 2	CHAIN 0	CHAIN 1	CHAIN 2	CHAIN 0	CHAIN 1	CHAIN 2		
42	5210	4.30	5.73	6.88	-5.11	-4.51	-4.20	9.41	10.24	11.08	13	PASS



A D T

### For Chain (2): CH 42

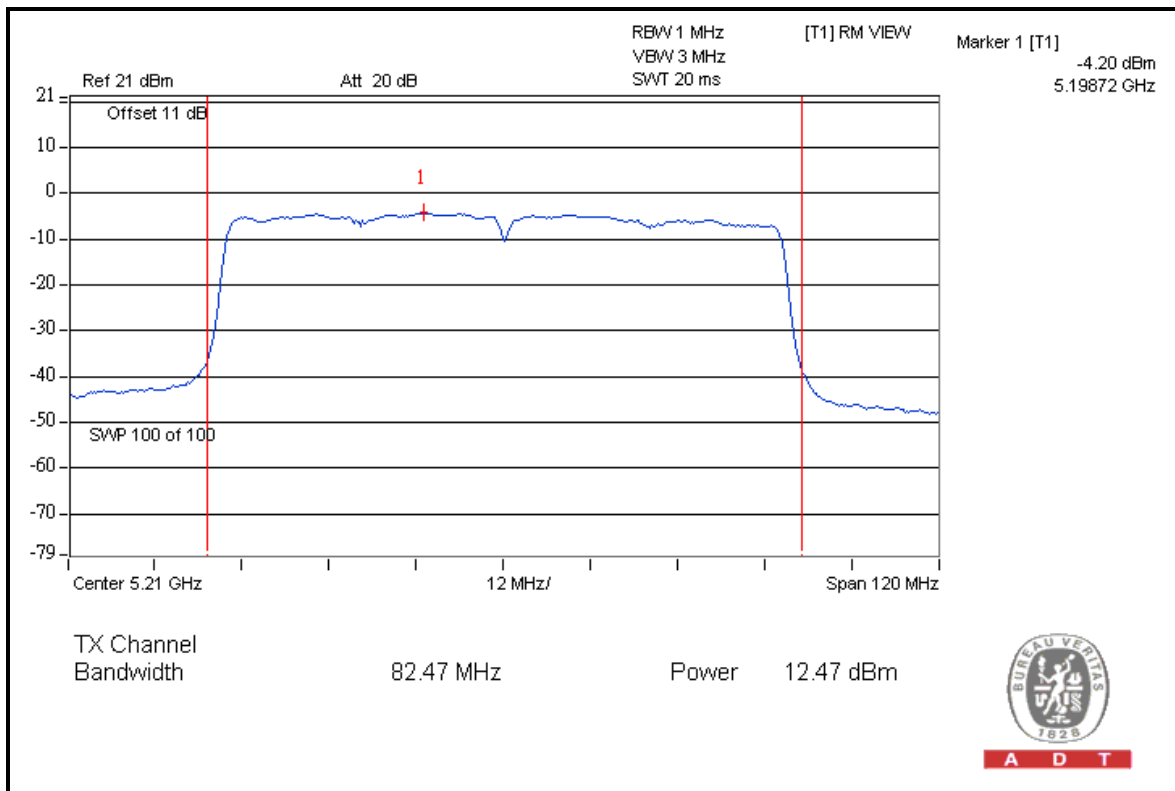
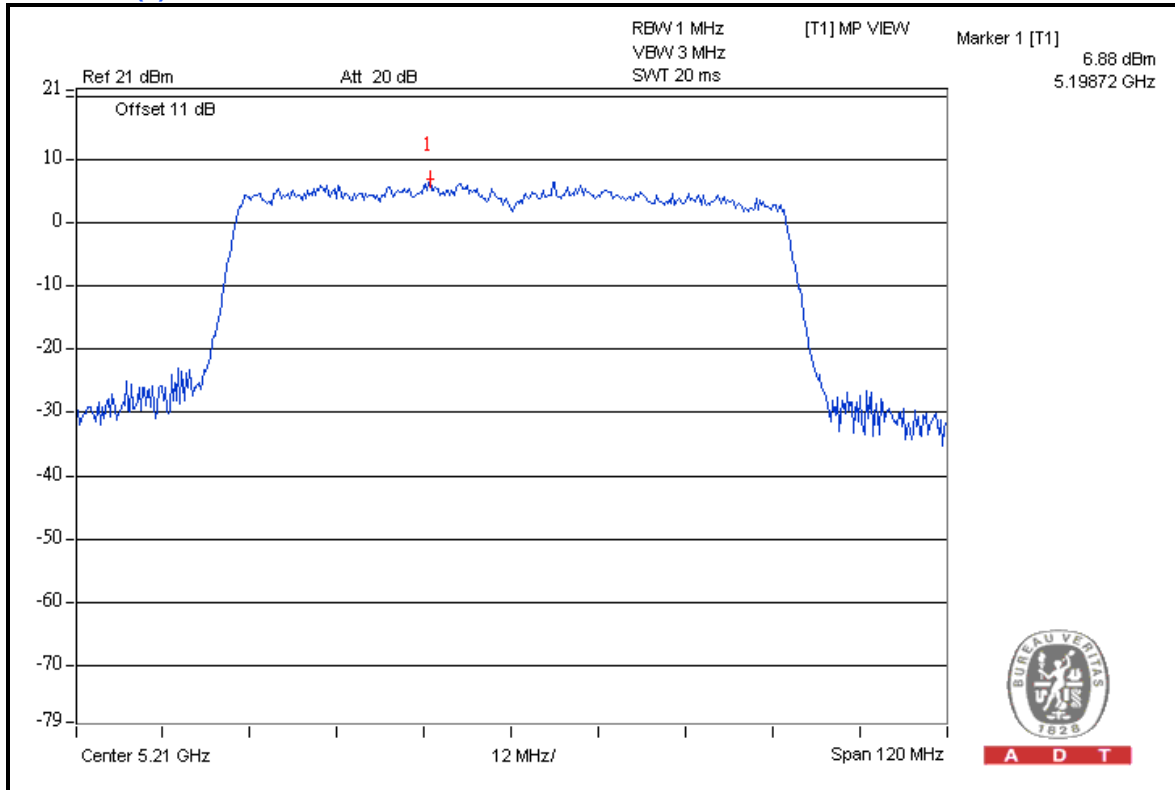



## 4.6 FREQUENCY STABILITY

### 4.6.1 LIMITS OF FREQUENCY STABILITY MEASUREMENT

The frequency of the carrier signal shall be maintained within band of operation

### 4.6.2 TEST INSTRUMENTS

DESCRIPTION & MANUFACTURER	MODEL NO.	SERIAL NO.	CALIBRATED DATE	CALIBRATED UNTIL
R&S Spectrum Analyzer	FSP40	100036	Dec. 14, 2011	Dec. 13, 2012

**Note:**

1. The calibration interval of the above test instruments is 12 months and the calibrations are traceable to NML/ROC and NIST/USA.
2. Tested date : July 04, 2012

### 4.6.3 TEST PROCEDURE

1. The EUT was placed inside the environmental test chamber and powered by nominal AC voltage.
2. Turn the EUT on and couple its output to a spectrum analyzer.
3. Turn the EUT off and set the chamber to the highest temperature specified.
4. Allow sufficient time (approximately 30 min) for the temperature of the chamber to stabilize, turn the EUT on and measure the operating frequency after 2, 5, and 10 minutes.
5. Repeat step 2 and 3 with the temperature chamber set to the lowest temperature.
6. The test chamber was allowed to stabilize at +20 degree C for a minimum of 30 minutes. The supply voltage was then adjusted on the EUT from 85% to 115% and the frequency record.

#### 4.6.4 DEVIATION FROM TEST STANDARD

No deviation

#### 4.6.5 TEST SETUP

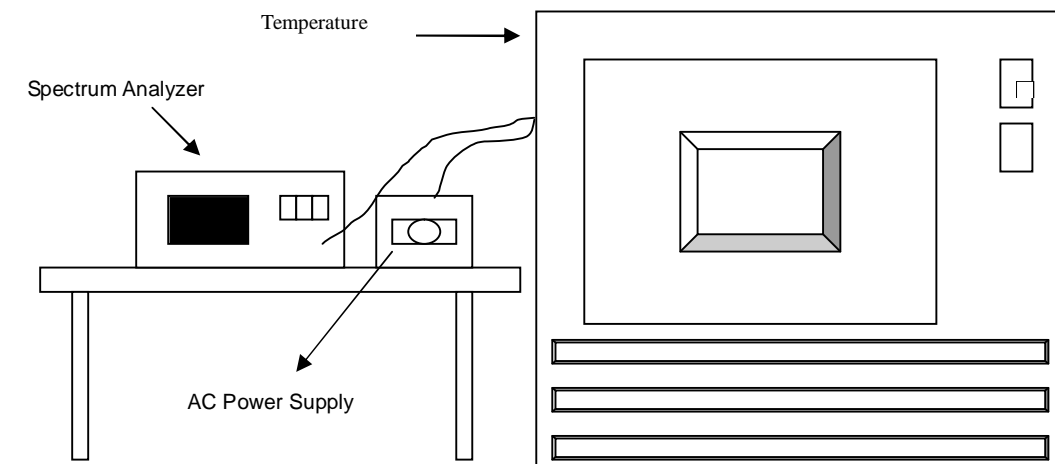

#### 4.6.6 EUT OPERATING CONDITION

Set the EUT transmit at un-modulation mode to test frequency stability.



A D T

#### 4.6.7 TEST RESULTS

FREQUENCY STABILITY VERSUS TEMP.									
OPERATING FREQUENCY: 5240MHz									
TEMP. (°C)	POWER SUPPLY (Vac)	0 MINUTE		2 MINUTE		5 MINUTE		10 MINUTE	
		Measured Frequency	Frequency Drift	Measured Frequency	Frequency Drift	Measured Frequency	Frequency Drift	Measured Frequency	Frequency Drift
		(MHz)	ppm	(MHz)	ppm	(MHz)	ppm	(MHz)	ppm
50	120	5240.0122	2.3282	5240.0111	2.1183	5240.0141	2.6908	5240.0112	2.1374
40	120	5239.9793	-3.9504	5239.9834	-3.1679	5239.9806	-3.7023	5239.9821	-3.4160
30	120	5239.985	-2.8626	5239.9878	-2.3282	5239.9882	-2.2519	5239.992	-1.5267
20	120	5239.9934	-1.2595	5239.9959	-0.7824	5239.9985	-0.2863	5239.9989	-0.2099
10	120	5239.9936	-1.2214	5239.9981	-0.3626	5239.9936	-1.2214	5239.988	-2.2901
0	120	5240.006	1.1450	5240.0102	1.9466	5240.0101	1.9275	5240.0113	2.1565
-10	120	5240.018	3.4351	5240.014	2.6718	5240.0121	2.3092	5240.0171	3.2634
-20	120	5240.0046	0.8779	5240.0027	0.5153	5240.0021	0.4008	5240.0004	0.0763
-30	120	5239.9927	-1.3931	5239.9977	-0.4389	5239.9991	-0.1718	5240.0045	0.8588

FREQUENCY STABILITY VERSUS VOLTAGE									
OPERATING FREQUENCY: 5240MHz									
TEMP. (°C)	POWER SUPPLY (Vac)	0 MINUTE		2 MINUTE		5 MINUTE		10 MINUTE	
		Measured Frequency	Frequency Drift	Measured Frequency	Frequency Drift	Measured Frequency	Frequency Drift	Measured Frequency	Frequency Drift
		(MHz)	ppm	(MHz)	ppm	(MHz)	ppm	(MHz)	ppm
20	138	5239.9934	-1.2595	5239.994	-1.1450	5239.9991	-0.1718	5239.9995	-0.0954
	120	5239.9934	-1.2595	5239.9959	-0.7824	5239.9985	-0.2863	5239.9989	-0.2099
	102	5239.9918	-1.5649	5239.9944	-1.0687	5239.9987	-0.2481	5239.9987	-0.2481



A D T

## 5. PHOTOGRAPHS OF THE TEST CONFIGURATION

Please refer to the attached file (Test Setup Photo).





## 6. INFORMATION ON THE TESTING LABORATORIES

We, Bureau Veritas Consumer Products Services (H.K.) Ltd., Taoyuan Branch, were founded in 1988 to provide our best service in EMC, Radio, Telecom and Safety consultation. Our laboratories are accredited and approved according to ISO/IEC 17025.

If you have any comments, please feel free to contact us at the following:

**Linko EMC/RF Lab:**

Tel: 886-2-26052180

Fax: 886-2-26052943

**Hsin Chu EMC/RF Lab:**

Tel: 886-3-5935343

Fax: 886-3-5935342

**Hwa Ya EMC/RF/Safety/Telecom Lab:**

Tel: 886-3-3183232

Fax: 886-3-3270892

**Email:** [service.adt@tw.bureauveritas.com](mailto:service.adt@tw.bureauveritas.com)

**Web Site:** [www.adt.com.tw](http://www.adt.com.tw)

The address and road map of all our labs can be found in our web site also.



A D T

## **7.APPENDIX A - MODIFICATIONS RECORDERS FOR ENGINEERING CHANGES TO THE EUT BY THE LAB**

No modifications were made to the EUT by the lab during the test.

**--- END ---**