



FCC 47 CFR PART 15 SUBPART C

TEST REPORT

For

Wireless Compact Router

Model: WRT54GC V3

Trade Name: Linksys

Issued to

Cisco-Linksys LLC.
121 Theory Drive Irvine, CA 92617

Issued by

Compliance Certification Services Inc.
No. 11, Wu-Gong 6th Rd., Wugu Industrial Park,
Taipei Hsien 248, Taiwan (R.O.C.)
<http://www.ccsemc.com.tw>
service@tw.ccsemc.com



Note: This report shall not be reproduced except in full, without the written approval of Compliance Certification Services Inc. This document may be altered or revised by Compliance Certification Services Inc. personnel only, and shall be noted in the revision section of the document.



TABLE OF CONTENTS

- 1. TEST RESULT CERTIFICATION..... 3**
- 2. EUT DESCRIPTION..... 4**
- 3. TEST METHODOLOGY 5**
 - 3.1 EUT CONFIGURATION.....5
 - 3.2 EUT EXERCISE5
 - 3.3 GENERAL TEST PROCEDURES5
 - 3.4 FCC PART 15.205 RESTRICTED BANDS OF OPERATIONS.....6
 - 3.5 DESCRIPTION OF TEST MODES7
- 4. INSTRUMENT CALIBRATION..... 8**
 - 4.1 MEASURING INSTRUMENT CALIBRATION.....8
 - 4.2 MEASUREMENT EQUIPMENT USED.....8
- 5. FACILITIES AND ACCREDITATIONS..... 10**
 - 5.1 FACILITIES 10
 - 5.2 EQUIPMENT 10
 - 5.3 TABLE OF ACCREDITATIONS AND LISTINGS..... 11
- 6. SETUP OF EQUIPMENT UNDER TEST 12**
 - 6.1 SETUP CONFIGURATION OF EUT.....12
 - 6.2 SUPPORT EQUIPMENT.....12
- 7. FCC PART 15.247 REQUIREMENTS 13**
 - 7.1 6DB BANDWIDTH.....13
 - 7.2 PEAK POWER18
 - 7.3 AVERAGE POWER22
 - 7.4 BAND EDGES MEASUREMENT.....27
 - 7.5 PEAK POWER SPECTRAL DENSITY.....36
 - 7.6 SPURIOUS EMISSIONS.....41
 - 7.7 POWERLINE CONDUCTED EMISSIONS55
- APPENDIX I RADIO FREQUENCY EXPOSURE..... 58**
- APPENDIX II PHOTOGRAPHS OF TEST SETUP 60**



1. TEST RESULT CERTIFICATION

Applicant: Cisco-Linksys LLC.
121 Theory Drive Irvine, CA 92617

Equipment Under Test: Wireless Compact Router

Trade Name: Linksys

Model: WRT54GC V3

Date of Test: July 29 ~ August 4, 2008

APPLICABLE STANDARDS	
STANDARD	TEST RESULT
FCC 47 CFR Part 15 Subpart C	No non-compliance noted
Deviation from Applicable Standard	
None	

We hereby certify that:

The above equipment was tested by Compliance Certification Services Inc. The test data, data evaluation, test procedures, and equipment configurations shown in this report were made in accordance with the procedures given in **ANSI C63.4: 2003** and the energy emitted by the sample EUT tested as described in this report is in compliance with the requirements of FCC Rules Part 15.207, 15.209, 15.247.

The test results of this report relate only to the tested sample EUT identified in this report.

Approved by:

Reviewed by:

Rex Lai
Section Manager
Compliance Certification Services Inc.

Amanda Wu
Section Manager
Compliance Certification Services Inc.



2. EUT DESCRIPTION

Product	Wireless Compact Router
Trade Name	Linksys
Model Number	WRT54GC V3
Model Discrepancy	N/A
Power Supply	DVE / Model number: DSA-6G-05 FUK 050100 I/P: 100-240 ~ 50/60Hz 0.2A O/P: +5V, 1A DVE / Model number: DSA-6E-05 FUK 050100 I/P: 100-240 ~ 50/60Hz 0.2A O/P: +5V, 1A DVE / Model number: DSA-5W-05 FUK 050100 I/P: 100-240 ~ 50/60Hz 0.2A O/P: +5V, 1A
Frequency Range	2412 ~ 2462 MHz
Transmit Power	IEEE 802.11b: 16.56 dBm IEEE 802.11g: 17.44 dBm
Modulation Technique	IEEE 802.11b: DSSS (CCK, DQPSK, DBPSK) IEEE 802.11g: DSSS (CCK, DQPSK, DBPSK) + OFDM (QPSK, BPSK, 16-QAM, 64-QAM)
Transmit Data Rate	IEEE 802.11b Mode: 11, 5.5, 2, 1 Mbps IEEE 802.11g Mode: 54, 48, 36, 24, 18, 12, 11, 9, 6, 5.5, 2, 1Mbps
Number of Channels	11 Channels
Antenna Specification	1.8 dBi
Antenna Designation	Dipole Antenna

Remark:

1. The sample selected for test was production product and was provided by manufacturer.
2. This submittal(s) (test report) is intended for FCC ID: **Q87-WRT54GCV3** filing to comply with Section 15.207, 15.209 and 15.247 of the FCC Part 15, Subpart C Rules.



3. TEST METHODOLOGY

The tests documented in this report were performed in accordance with ANSI C63.4 and FCC CFR 47 2.1046, 2.1047, 2.1049, 2.1051, 2.1053, 2.1055, 2.1057, 15.207, 15.209 and 15.247.

3.1 EUT CONFIGURATION

The EUT configuration for testing is installed on RF field strength measurement to meet the Commissions requirement and operating in a manner that intends to maximize its emission characteristics in a continuous normal application.

3.2 EUT EXERCISE

The EUT was operated in the engineering mode to fix the TX frequency that was for the purpose of the measurements.

According to its specifications, the EUT must comply with the requirements of the Section 15.207, 15.209 and 15.247 under the FCC Rules Part 15 Subpart C.

3.3 GENERAL TEST PROCEDURES

Conducted Emissions

The EUT is placed on the turntable, which is 0.8 m above ground plane. According to the requirements in Section 13.1.4.1 of ANSI C63.4 Conducted emissions from the EUT measured in the frequency range between 0.15 MHz and 30MHz using CISPR Quasi-peak and average detector modes.

Radiated Emissions

The EUT is placed on a turn table, which is 0.8 m above ground plane. The turntable shall rotate 360 degrees to determine the position of maximum emission level. EUT is set 3m away from the receiving antenna, which varied from 1m to 4m to find out the highest emission. And also, each emission was to be maximized by changing the polarization of receiving antenna both horizontal and vertical. In order to find out the maximum emissions, exploratory radiated emission measurements were made according to the requirements in Section 13.1.4.1 of ANSI C63.4.



3.4 FCC PART 15.205 RESTRICTED BANDS OF OPERATIONS

(a) Except as shown in paragraph (d) of this section, only spurious emissions are permitted in any of the frequency bands listed below:

MHz	MHz	MHz	GHz
0.090 - 0.110	16.42 - 16.423	399.9 - 410	4.5 - 5.15
¹ 0.495 - 0.505	16.69475 - 16.69525	608 - 614	5.35 - 5.46
2.1735 - 2.1905	16.80425 - 16.80475	960 - 1240	7.25 - 7.75
4.125 - 4.128	25.5 - 25.67	1300 - 1427	8.025 - 8.5
4.17725 - 4.17775	37.5 - 38.25	1435 - 1626.5	9.0 - 9.2
4.20725 - 4.20775	73 - 74.6	1645.5 - 1646.5	9.3 - 9.5
6.215 - 6.218	74.8 - 75.2	1660 - 1710	10.6 - 12.7
6.26775 - 6.26825	108 - 121.94	1718.8 - 1722.2	13.25 - 13.4
6.31175 - 6.31225	123 - 138	2200 - 2300	14.47 - 14.5
8.291 - 8.294	149.9 - 150.05	2310 - 2390	15.35 - 16.2
8.362 - 8.366	156.52475 -	2483.5 - 2500	17.7 - 21.4
8.37625 - 8.38675	156.52525	2655 - 2900	22.01 - 23.12
8.41425 - 8.41475	156.7 - 156.9	3260 - 3267	23.6 - 24.0
12.29 - 12.293	162.0125 - 167.17	3332 - 3339	31.2 - 31.8
12.51975 - 12.52025	167.72 - 173.2	3345.8 - 3358	36.43 - 36.5
12.57675 - 12.57725	240 - 285	3600 - 4400	(²)
13.36 - 13.41	322 - 335.4		

¹ Until February 1, 1999, this restricted band shall be 0.490-0.510 MHz.

² Above 38.6

(b) Except as provided in paragraphs (d) and (e), the field strength of emissions appearing within these frequency bands shall not exceed the limits shown in Section 15.209. At frequencies equal to or less than 1000 MHz, compliance with the limits in Section 15.209 shall be demonstrated using measurement instrumentation employing a CISPR quasi-peak detector. Above 1000 MHz, compliance with the emission limits in Section 15.209 shall be demonstrated based on the average value of the measured emissions. The provisions in Section 15.35 apply to these measurements.



3.5 DESCRIPTION OF TEST MODES

The EUT (model: WRT54GC V3) comes with three types of adapter for sale. After the preliminary test, the EUT with adapter (Model: DSA-6G-05 FUK 050100) was found to emit the worst emissions and therefore had been tested under operating condition.

Software used to control the EUT for staying in continuous transmitting mode was programmed.

After verification, all tests were carried out with the worst case test modes as shown below except radiated spurious emission below 1GHz and power line conducted emissions below 30MHz, which worst case was in normal link mode only.

IEEE 802.11b mode:

Channel 1(2412MHz), Channel 6(2437MHz) and Channel 11(2462MHz) with 11Mbps data rate were chosen for the final testing.

IEEE 802.11g mode:

Channel 1(2412MHz), Channel 6(2437MHz) and Channel 11(2462MHz) with 54Mbps data rate were chosen for the final testing.



4. INSTRUMENT CALIBRATION

4.1 MEASURING INSTRUMENT CALIBRATION

The measuring equipment, which was utilized in performing the tests documented herein, has been calibrated in accordance with the manufacturer's recommendations for utilizing calibration equipment, which is traceable to recognized national standards.

4.2 MEASUREMENT EQUIPMENT USED

Equipment Used for Emissions Measurement

Remark: Each piece of equipment is scheduled for calibration once a year.

Conducted Emissions Test Site				
Name of Equipment	Manufacturer	Model	Serial Number	Calibration Due
Spectrum Analyzer	Agilent	E4446A	MY43360131	02/24/2009

3M Semi Anechoic Chamber				
Name of Equipment	Manufacturer	Model	Serial Number	Calibration Due
Spectrum Analyzer	Agilent	E4446A	US42510252	09/10/2009
Test Receiver	Rohde&Schwarz	ESCI	100064	11/30/2009
Switch Controller	TRC	Switch Controller	SC94050010	05/03/2009
4 Port Switch	TRC	4 Port Switch	SC94050020	05/03/2009
Horn-Antenna	TRC	HA-0502	06	06/04/2009
Horn-Antenna	TRC	HA-0801	04	06/18/2009
Horn-Antenna	TRC	HA-1201A	01	08/10/2009
Horn-Antenna	TRC	HA-1301A	01	08/11/2009
Bilog- Antenna	Sunol Sciences	JB3	A030205	03/28/2009
Turn Table	Max-Full	MFT-120S	T120S940302	N.C.R.
Antenna Tower	Max-Full	MFA-430	A440940302	N.C.R.
Controller	Max-Full	MF-CM886	CC-C-1F-13	N.C.R.
Site NSA	CCS	N/A	FCC: 965860 IC: IC 6106	09/25/2008
Test S/W	LABVIEW (V 6.1)			

Remark: The measurement uncertainty is less than $\pm 3.7046\text{dB}$ (30MHz ~ 1GHz), $\pm 3.0958\text{dB}$ (Above 1GHz) which is evaluated as per the NAMAS NIS 81 and CISPR/A/291/CDV.



Powerline Conducted Emissions Test Site				
Name of Equipment	Manufacturer	Model	Serial Number	Calibration Due
EMI TEST RECEIVER 9kHz-30MHz	ROHDE & SCHWARZ	ESHS30	828144/003	11/18/2009
TWO-LINE V-NETWORK 9kHz-30MHz	SCHAFFNER	NNB41	03/10013	06/11/2009
LISN 10kHz-100MHz	EMCO	3825/2	9106-1809	04/09/2009
Test S/W	LABVIEW (V 6.1)			

Remark: The measurement uncertainty is less than +/- 2.81dB, which is evaluated as per the NAMAS NIS 81 and CISPR/A/291/CDV.



5. FACILITIES AND ACCREDITATIONS

5.1 FACILITIES

All measurement facilities used to collect the measurement data are located at

No.11, Wugong 6th Rd., Wugu Industrial Park, Taipei Hsien 248, Taiwan

Tel: 886-2-2299-9720 / Fax: 886-2-2298-4045

The sites are constructed in conformance with the requirements of ANSI C63.7, ANSI C63.4 and CISPR Publication 22.

5.2 EQUIPMENT





Radiated emissions are measured with one or more of the following types of linearly polarized antennas: tuned dipole, biconical, log periodic, bi-log, and/or ridged waveguide, horn. Spectrum analyzers with pre-selectors and quasi-peak detectors are used to perform radiated measurements.

Conducted emissions are measured with Line Impedance Stabilization Networks and EMI Test Receivers.

Calibrated wideband preamplifiers, coaxial cables, and coaxial attenuators are also used for making measurements.

All receiving equipment conforms to CISPR Publication 16-1, "Radio Interference Measuring Apparatus and Measurement Methods."

5.3 TABLE OF ACCREDITATIONS AND LISTINGS

Country	Agency	Scope of Accreditation	Logo
USA	A2LA	EN 55011, EN 55014-1/2, CISPR 11, CISPR 14-1/2, EN 55022, EN 55015, CISPR 22, CISPR 15, AS/NZS 3548, VCCI V3 (2001), CFR 47, FCC Part 15/18, CNS 13783-1, CNS 13439, CNS 13438, CNS 13803, CNS 14115, EN 55024, IEC 801-2, IEC 801-3, IEC 801-4, IEC/EN 61000-3-2, EIC/EN 61000-3-3, IEC/EN 61000-4-2/3/4/5/6/8/11, EN 50081-1/EN 61000-6-3, EN 50081-2/EN 61000-6-4, EN 50081-2/EN 61000-6-1: 2001	 ACCREDITED TESTING CERT #0824.01
USA	FCC	3M Semi Anechoic Chamber (965860 and 898658) to perform FCC Part 15/18 measurements	 965860, 898658
Taiwan	TAF	LP0002, RTTE01, FCC Method-47 CFR Part 15 Subpart C, D, E, RSS-210, RSS-310 IDA TS SRD, AS/NZS 4268, AS/NZS 4771, TS 12.1 & 12.2, ETSI EN 300 440-1, ETSI EN 300 440-2, ETSI EN 300 328, ETSI EN 300 220-1, ETSI EN 300 220-2, ETSI EN 301 893, ETSI EN 301 489-1/3/7/17 FCC OET Bulletin 65 + Supplement C, EN 50360, EN 50361, EN 50371, RSS 102, EN 50383, EN 50385, EN 50392, IEC 62209, CNS 14958-1, CNS 14959 FCC Method -47 CFR Part 15 Subpart B IEC / EN 61000-3-2, IEC / EN 61000-3-3, IEC / EN 61000-4-2/3/4/5/6/8/11	 Testing Laboratory 1309
Canada	Industry Canada	3M Semi Anechoic Chamber (IC 6106 & IC 6106A-2) to perform RSS 212 Issue 1	 IC 6106 IC 6106A-2

* No part of this report may be used to claim or imply product endorsement by A2LA or any agency of the US Government.



6. SETUP OF EQUIPMENT UNDER TEST

6.1 SETUP CONFIGURATION OF EUT

See test photographs attached in Appendix II for the actual connections between EUT and support equipment.

6.2 SUPPORT EQUIPMENT

No.	Device Type	Brand	Model	Series No.	FCC ID	Data Cable	Power Cord
1.	Notebook PC	IBM	2656	AK-VFOHT	FCC DoC	LAN Cable: Unshielded, 10m Line Cable: Unshielded, 10m	AC I/P: Unshielded, 1.8m DC O/P: Unshielded, 1.8m with a core
2.	Notebook PC (Remote)	IBM	2662	FX-T5362	FCC DoC	LAN Cable: Unshielded, 10m Line Cable: Unshielded, 10m	AC I/P: Unshielded, 1.8m DC O/P: Unshielded, 1.8m with a core
3.	Test Kit	N/A	N/A	N/A	N/A	N/A	N/A

Remark:

- All the equipment/cables were placed in the worst-case configuration to maximize the emission during the test.*
- Grounding was established in accordance with the manufacturer's requirements and conditions for the intended use.*



7. FCC PART 15.247 REQUIREMENTS

7.1 6DB BANDWIDTH

LIMIT

According to §15.247(a)(2), systems using digital modulation techniques may operate in the 902 - 928 MHz, 2400 - 2483.5 MHz, and 5725 - 5850 MHz bands. The minimum 6 dB bandwidth shall be at least 500 kHz.

Test Configuration

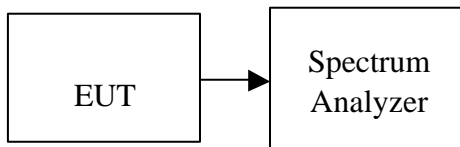

TEST PROCEDURE

1. Place the EUT on the table and set it in the transmitting mode.
2. Remove the antenna from the EUT and then connect a low loss RF cable from the antenna port to the spectrum analyzer.
3. Set the spectrum analyzer as RBW = 100kHz, VBW = RBW, Span = 50MHz, Sweep = auto.
4. Mark the peak frequency and -6dB (upper and lower) frequency.
5. Repeat until all the rest channels are investigated.

TEST RESULTS

No non-compliance noted.



Test mode: IEEE 802.11b

Channel	Frequency (MHz)	6Db Bandwidth (kHz)	Limit (kHz)	Result
Low	2412	9830	>500	PASS
Mid	2437	10000		PASS
High	2462	9500		PASS

Test mode: IEEE 802.11g

Channel	Frequency (MHz)	6Db Bandwidth (kHz)	Limit (kHz)	Result
Low	2412	16500	>500	PASS
Mid	2437	16420		PASS
High	2462	16500		PASS



Test Plot

IEEE 802.11b

6dB Bandwidth (CH Low)

Agilent 13:11:19 Aug 4, 2008

R T

6dB BW, b Mode Low Ch.

Δ Mkr1 9.83 MHz

Ref 20 dBm

Atten 20 dB

1.25 dB

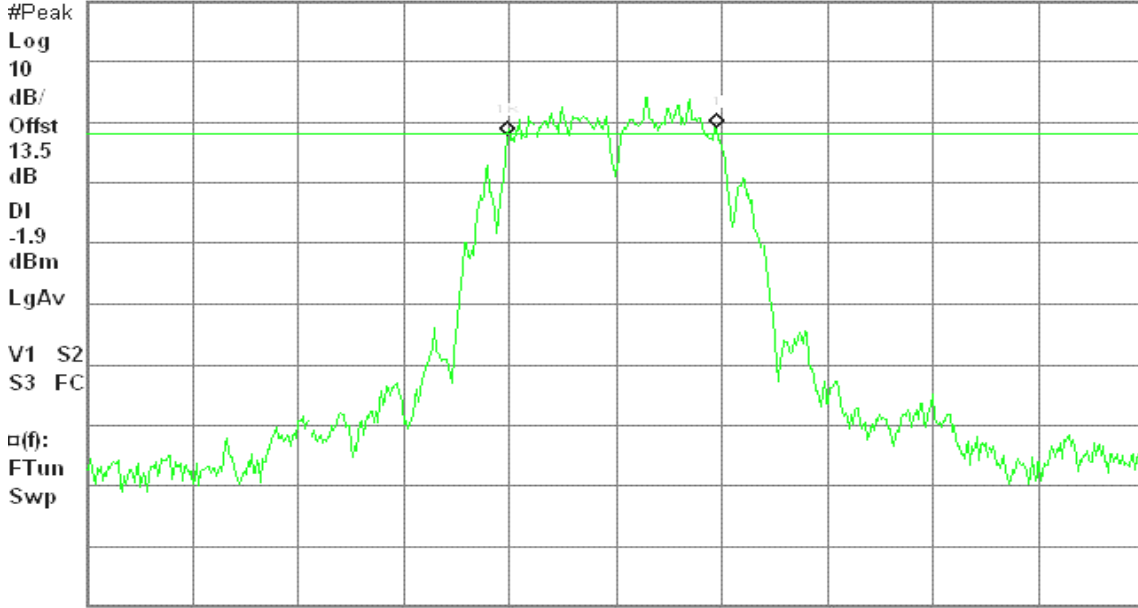

Center 2.412 00 GHz

Span 50 MHz

#Res BW 100 kHz

#VBW 100 kHz

Sweep 6.04 ms (601 pts)

6dB Bandwidth (CH Mid)

Agilent 13:19:15 Aug 4, 2008

R T

6dB BW, b Mode Mid Ch.

Δ Mkr1 10.00 MHz

Ref 20 dBm

Atten 20 dB

0.98 dB

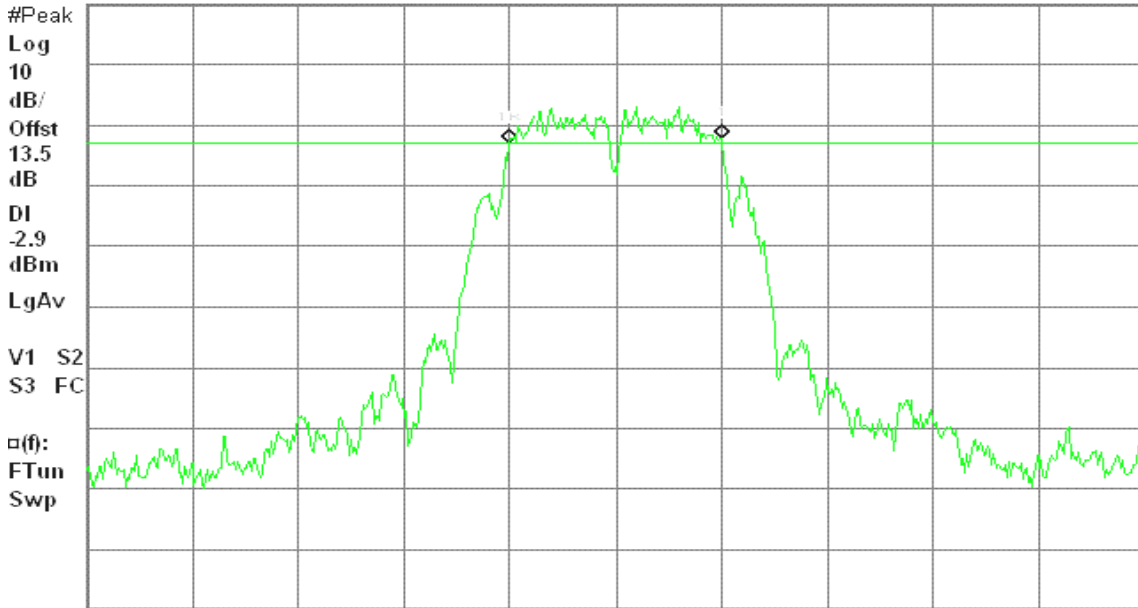

Center 2.437 00 GHz

Span 50 MHz

#Res BW 100 kHz

#VBW 100 kHz

Sweep 6.04 ms (601 pts)



6dB Bandwidth (CH High)

Agilent 13:29:42 Aug 4, 2008

R T

6dB BW, b Mode High Ch.

Δ Mkr1 9.50 MHz

Ref 20 dBm

Atten 20 dB

0.35 dB

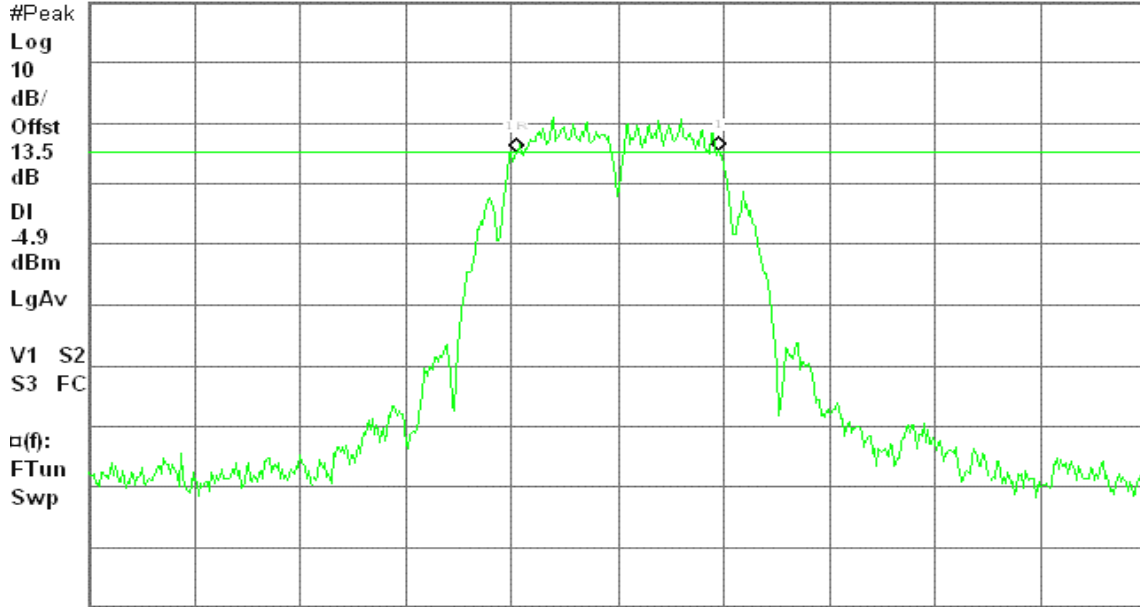

Center 2.462 00 GHz

Span 50 MHz

#Res BW 100 kHz

#VBW 100 kHz

Sweep 6.04 ms (601 pts)

IEEE 802.11g

6dB Bandwidth (CH Low)

Agilent 13:42:09 Aug 4, 2008

R T

6dB BW, g Mode Low Ch.

Δ Mkr1 16.50 MHz

Ref 20 dBm

Atten 20 dB

0.31 dB

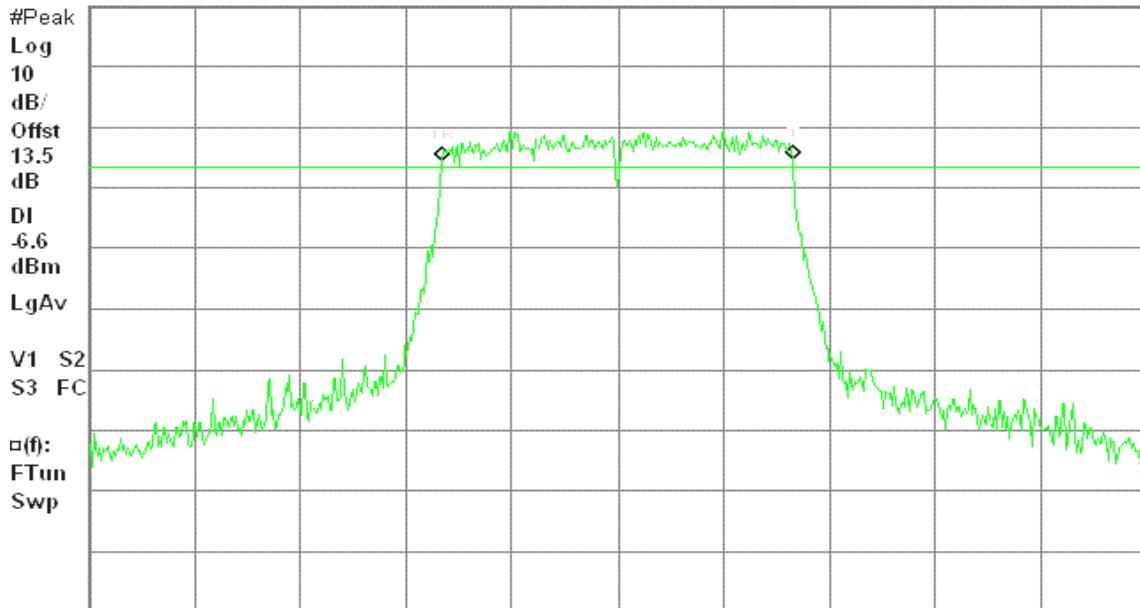

Center 2.412 00 GHz

Span 50 MHz

#Res BW 100 kHz

#VBW 100 kHz

Sweep 6.04 ms (601 pts)



6dB Bandwidth (CH Mid)

Agilent 13:51:59 Aug 4, 2008

R T

6dB BW, g Mode Mid Ch.

Δ Mkr1 16.42 MHz

Ref 20 dBm

Atten 20 dB

0.81 dB

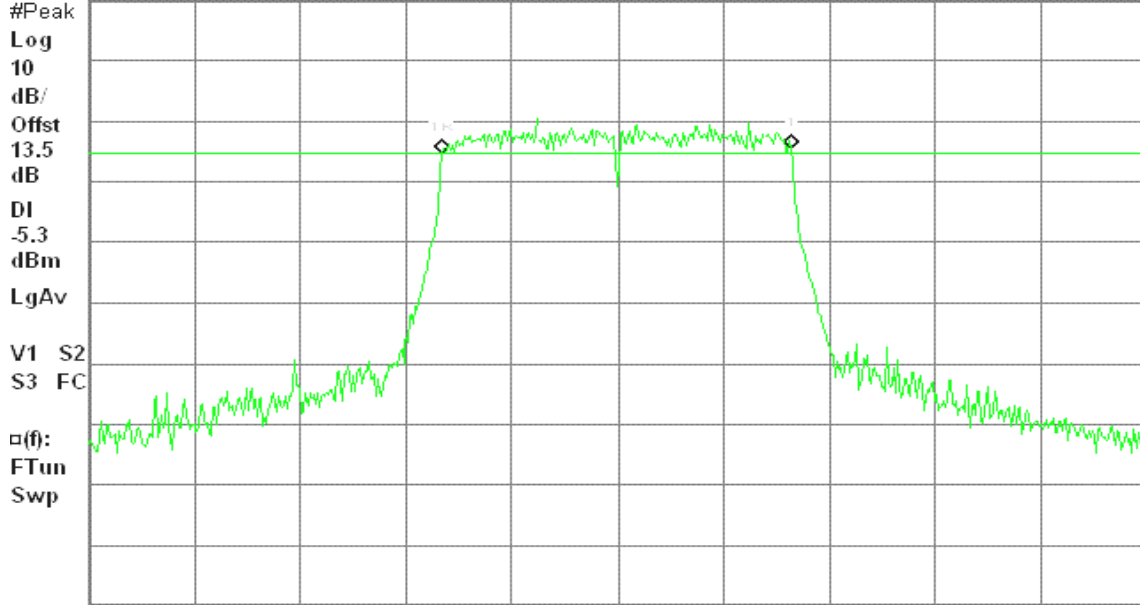

Center 2.437 00 GHz

Span 50 MHz

#Res BW 100 kHz

#VBW 100 kHz

Sweep 6.04 ms (601 pts)

6dB Bandwidth (CH High)

Agilent 14:02:10 Aug 4, 2008

R T

6dB BW, g Mode High Ch.

Δ Mkr1 16.50 MHz

Ref 20 dBm

Atten 20 dB

-2.33 dB

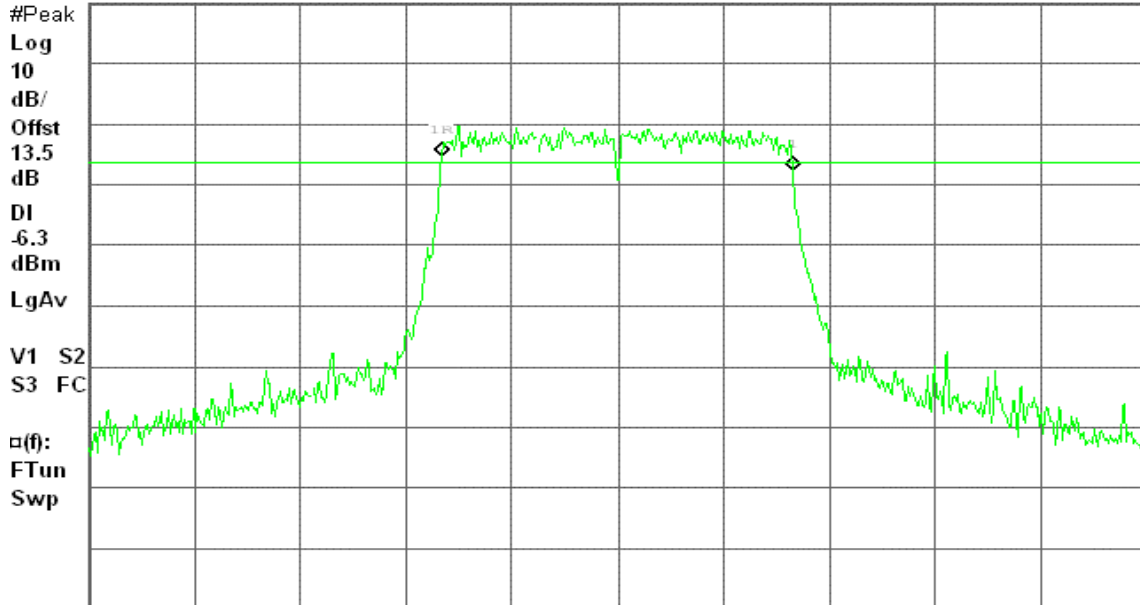

Center 2.462 00 GHz

Span 50 MHz

#Res BW 100 kHz

#VBW 100 kHz

Sweep 6.04 ms (601 pts)



7.2 PEAK POWER

LIMIT

The maximum peak output power of the intentional radiator shall not exceed the following:

1. According to §15.247(b)(3), for systems using digital modulation in the bands of 902-928 MHz, 2400-2483.5 MHz, and 5725-5850 MHz: 1 Watt.
2. According to §15.247(b)(4), the conducted output power limit specified in paragraph (b) of this section is based on the use of antennas with directional gains that do not exceed 6 dBi. Except as shown in paragraph (c) of this section, if transmitting antennas of directional gain greater than 6 dBi are used, the conducted output power from the intentional radiator shall be reduced below the stated values in paragraphs (b)(1), (b)(2), and (b)(3) of this section, as appropriate, by the amount in dB that the directional gain of the antenna exceeds 6 dBi.

Test Configuration

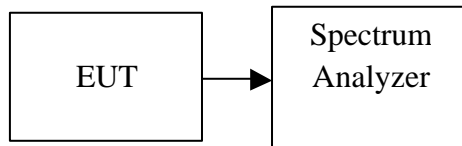

TEST PROCEDURE

1. Peak power is measured using the spectrum analyzer's internal channel power integration function.
2. Power is integrated over a bandwidth greater than or equal to the 99% bandwidth.

TEST RESULTS

No non-compliance noted.

Test mode: IEEE 802.11b

Channel	Frequency (MHz)	Output Power (dBm)	Output Power (W)	Limit (W)	Result
Low	2412	16.56	0.04529	1.00	PASS
Mid	2437	16.60	0.04571		PASS
High	2462	13.56	0.02270		PASS

Test mode: IEEE 802.11g

Channel	Frequency (MHz)	Output Power (dBm)	Output Power (W)	Limit (W)	Result
Low	2412	17.22	0.05272	1.00	PASS
Mid	2437	17.41	0.05508		PASS
High	2462	17.44	0.05546		PASS



Test Plot

IEEE 802.11b

Peak Power (CH Low)

Agilent 13:12:34 Aug 4, 2008

R T

Peak Output Power , b Mode Low Ch.

Ref 20 dBm

Atten 20 dB

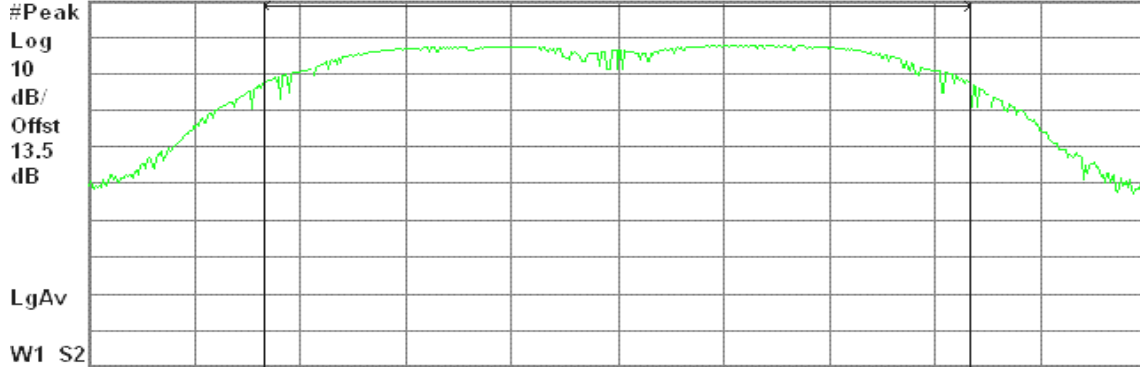

Center 2.412 00 GHz

Span 17.77 MHz

#Res BW 1 MHz

#VBW 3 MHz

Sweep 1 ms (601 pts)

Channel Power

Power Spectral Density

16.56 dBm / 11.8440 MHz

-54.17 dBm/Hz

Peak Power (CH Mid)

Agilent 13:20:25 Aug 4, 2008

R T

Peak Output Power , b Mode Mid Ch.

Ref 20 dBm

Atten 20 dB

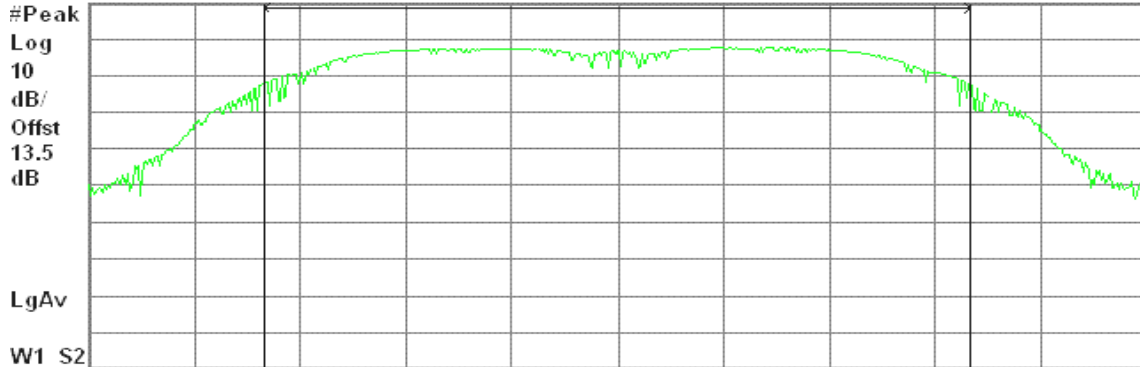

Center 2.437 00 GHz

Span 17.68 MHz

#Res BW 1 MHz

#VBW 3 MHz

Sweep 1 ms (601 pts)

Channel Power

Power Spectral Density

16.60 dBm / 11.7860 MHz

-54.11 dBm/Hz



Peak Power (CH High)

Agilent 13:31:33 Aug 4, 2008

R T

Peak Output Power , b Mode High Ch.

Ref 20 dBm

Atten 20 dB

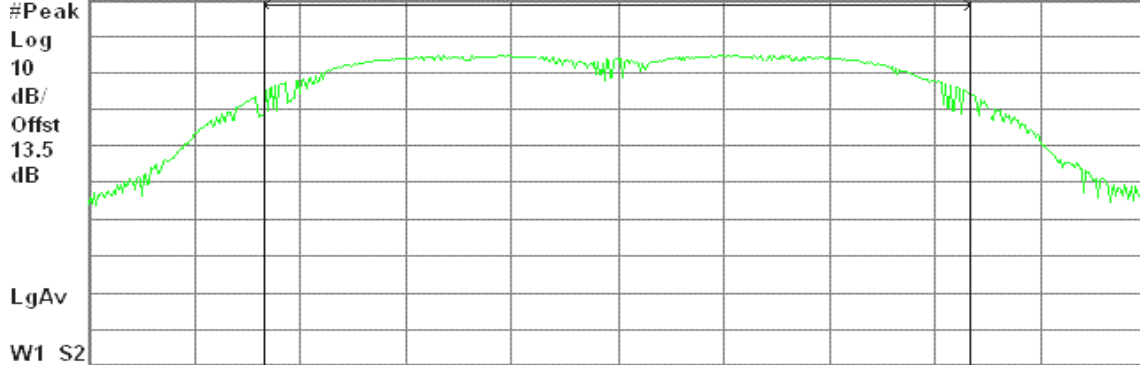

Center 2.462 00 GHz

Span 17.74 MHz

#Res BW 1 MHz

#VBW 3 MHz

Sweep 1 ms (601 pts)

Channel Power

Power Spectral Density

13.56 dBm / 11.8280 MHz

-57.17 dBm/Hz

IEEE 802.11g

Peak Power (CH Low)

Agilent 13:43:36 Aug 4, 2008

R T

Peak Output Power , g Mode Low Ch.

Ref 20 dBm

Atten 20 dB

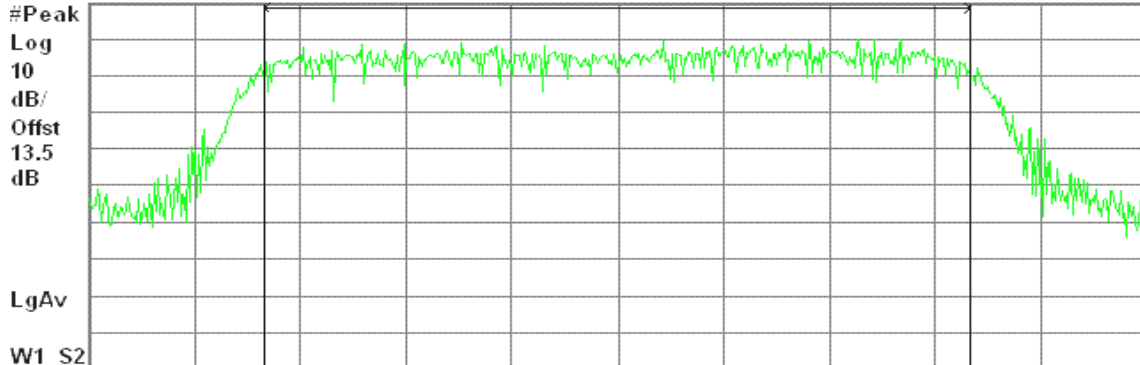

Center 2.412 00 GHz

Span 24.63 MHz

#Res BW 1 MHz

#VBW 3 MHz

Sweep 1 ms (601 pts)

Channel Power

Power Spectral Density

17.22 dBm / 16.4220 MHz

-54.94 dBm/Hz



Peak Power (CH Mid)

Agilent 13:53:47 Aug 4, 2008

R T

Peak Output Power , g Mode Mid Ch.

Ref 20 dBm

Atten 20 dB

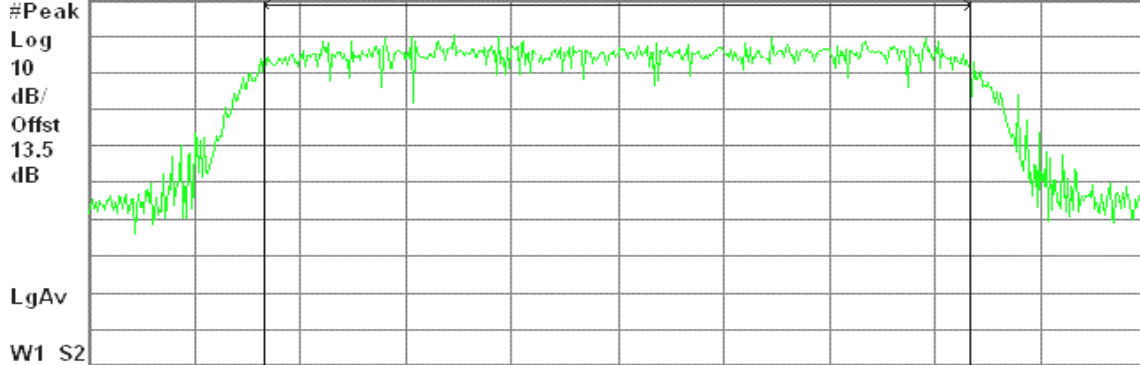

Center 2.437 00 GHz

Span 24.64 MHz

#Res BW 1 MHz

#VBW 3 MHz

Sweep 1 ms (601 pts)

Channel Power

Power Spectral Density

17.41 dBm / 16.4280 MHz

-54.74 dBm/Hz

Peak Power (CH High)

Agilent 14:03:06 Aug 4, 2008

R T

Peak Output Power , g Mode High Ch.

Ref 20 dBm

Atten 20 dB

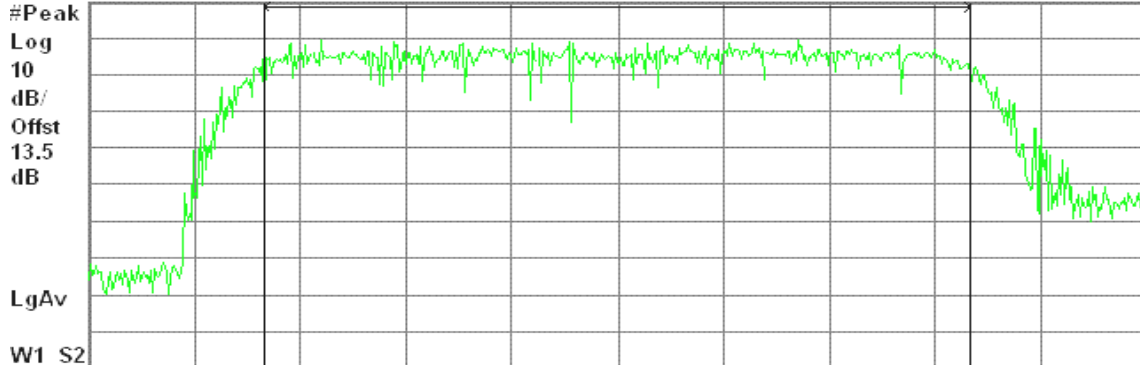

Center 2.462 00 GHz

Span 24.63 MHz

#Res BW 1 MHz

#VBW 3 MHz

Sweep 1 ms (601 pts)

Channel Power

Power Spectral Density

17.44 dBm / 16.4200 MHz

-54.72 dBm/Hz



7.3 AVERAGE POWER

LIMIT

None; for reporting purposes only.

Test Configuration

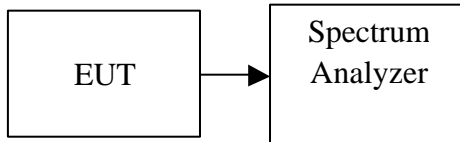

TEST PROCEDURE

The transmitter output is connected to the Spectrum analyzer. The Spectrum analyzer is set to the average power detection.

TEST RESULTS

No non-compliance noted.



Test Data

Test mode: IEEE 802.11b mode

Channel	Frequency (MHz)	Output Power (dBm)
Low	2412	13.94
Mid	2437	13.98
High	2462	10.88

Test mode: IEEE 802.11g mode

Channel	Frequency (MHz)	Output Power (dBm)
Low	2412	14.05
Mid	2437	14.21
High	2462	14.14



Test Plot

IEEE 802.11b

Average Power (CH Low)

Agilent 13:13:52 Aug 4, 2008

R T

AVG Output Power , b Mode Low Ch.

Ref 30 dBm

Atten 30 dB

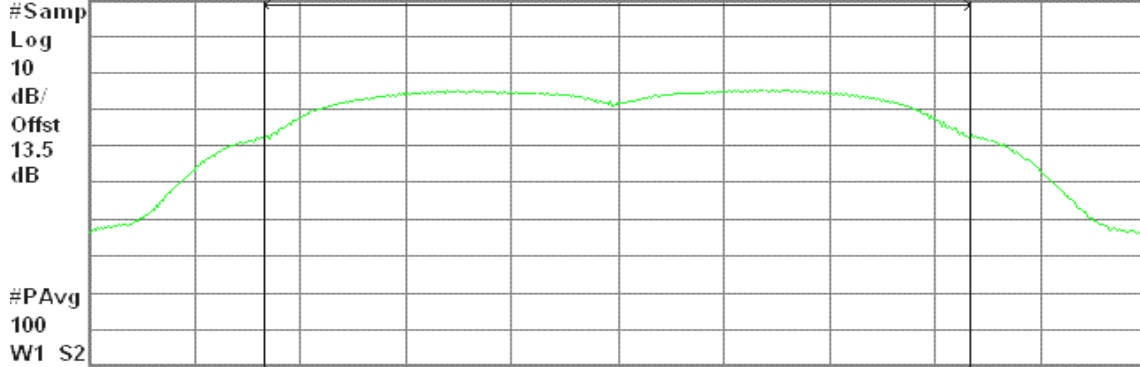

Center 2.412 00 GHz

Span 17.77 MHz

#Res BW 1 MHz

#VBW 3 MHz

Sweep 1 ms (601 pts)

Channel Power

Power Spectral Density

13.94 dBm / 11.8440 MHz

-56.79 dBm/Hz

Average Power (CH Mid)

Agilent 13:22:43 Aug 4, 2008

R T

AVG Output Power , b Mode Mid Ch.

Ref 30 dBm

Atten 30 dB

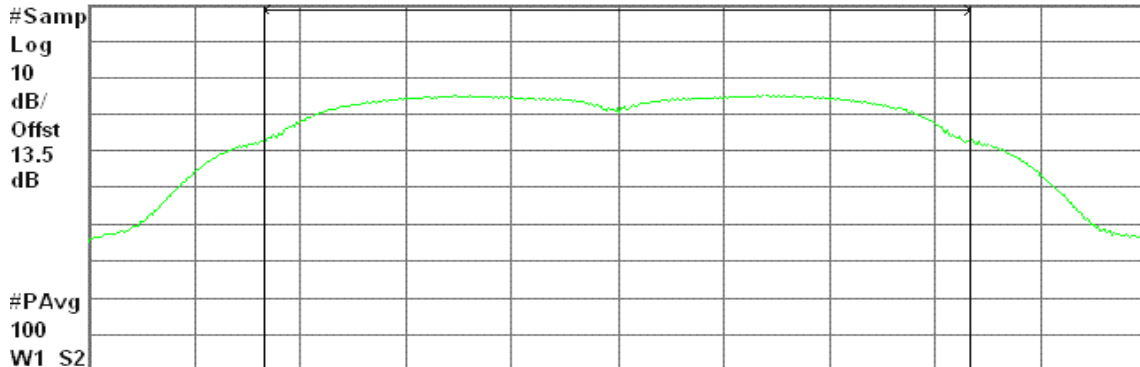

Center 2.437 00 GHz

Span 17.68 MHz

#Res BW 1 MHz

#VBW 3 MHz

Sweep 1 ms (601 pts)

Channel Power

Power Spectral Density

13.98 dBm / 11.7860 MHz

-56.73 dBm/Hz



Average Power (CH High)

Agilent 13:32:40 Aug 4, 2008

R T

AVG Output Power , b Mode High Ch.

Ref 30 dBm

Atten 30 dB

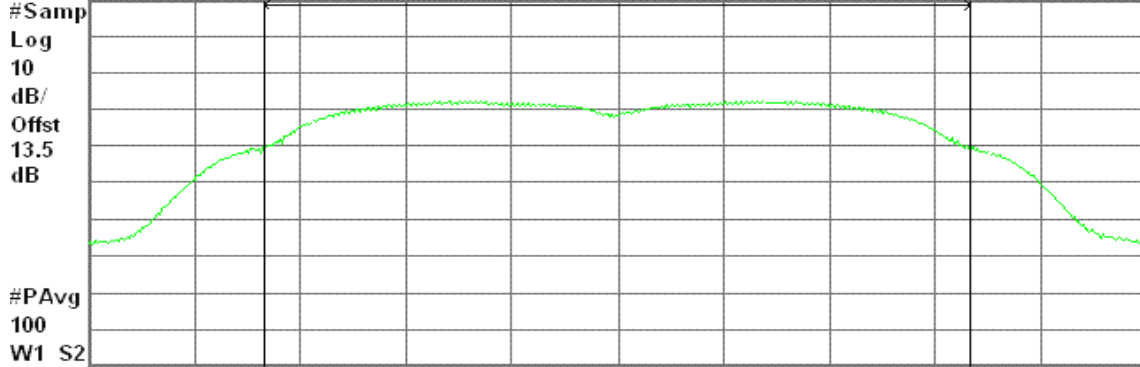

Center 2.462 00 GHz

Span 17.74 MHz

#Res BW 1 MHz

#VBW 3 MHz

Sweep 1 ms (601 pts)

Channel Power

Power Spectral Density

10.88 dBm / 11.8280 MHz

-59.85 dBm/Hz

IEEE 802.11g

Average Power (CH Low)

Agilent 13:45:24 Aug 4, 2008

R T

AVG Output Power , g Mode Low Ch.

Ref 30 dBm

Atten 30 dB

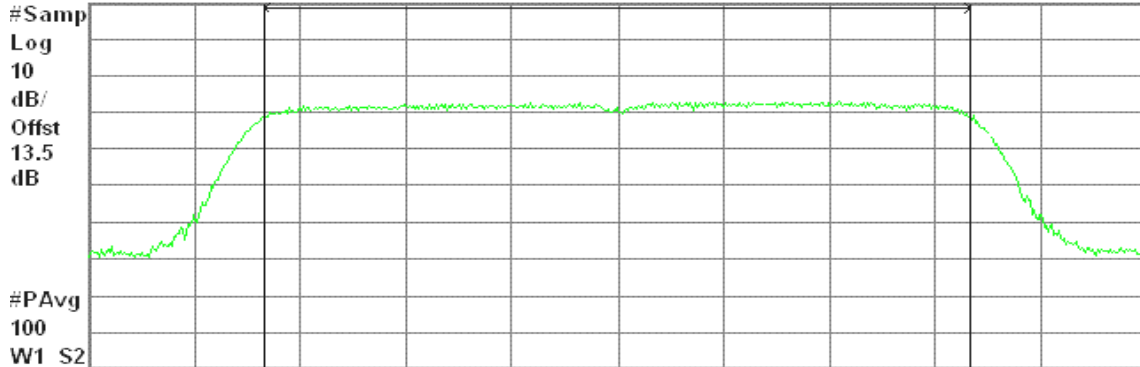

Center 2.412 00 GHz

Span 24.63 MHz

#Res BW 1 MHz

#VBW 3 MHz

Sweep 1 ms (601 pts)

Channel Power

Power Spectral Density

14.05 dBm / 16.4220 MHz

-58.11 dBm/Hz



Average Power (CH Mid)

Agilent 13:55:25 Aug 4, 2008

R T

AVG Output Power , g Mode Mid Ch.

Ref 30 dBm

Atten 30 dB

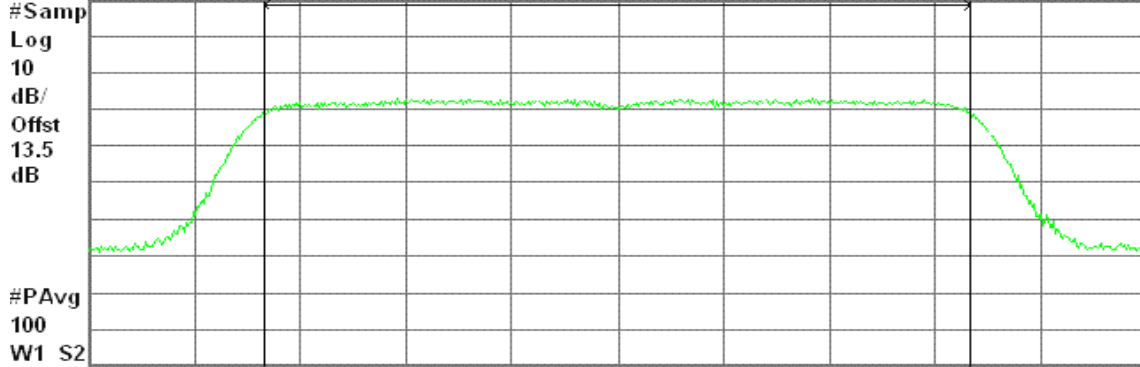

Channel Power

14.21 dBm / 16.4280 MHz

Power Spectral Density

-57.94 dBm/Hz

Average Power (CH High)

Agilent 14:05:01 Aug 4, 2008

R T

AVG Output Power , g Mode High Ch.

Ref 30 dBm

Atten 30 dB

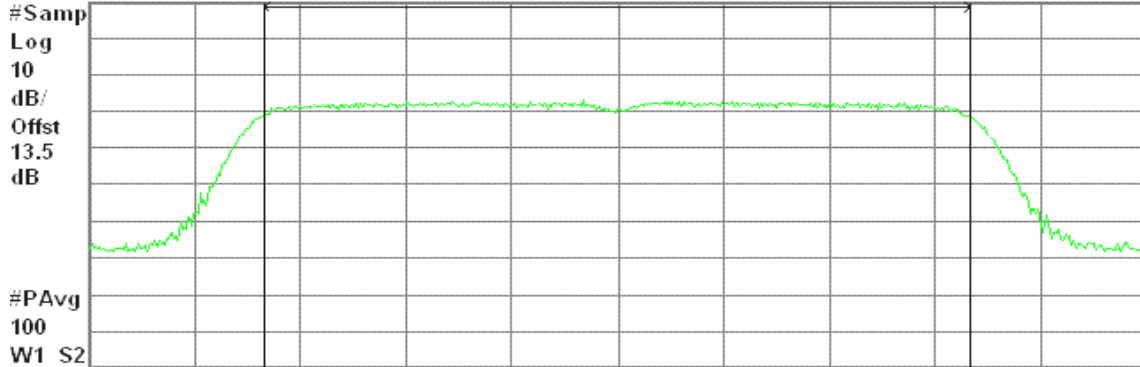

Channel Power

14.14 dBm / 16.4200 MHz

Power Spectral Density

-58.02 dBm/Hz

7.4 BAND EDGES MEASUREMENT

LIMIT

According to §15.247(d), in any 100 kHz bandwidth outside the frequency bands in which the spread spectrum intentional radiator is operating, the radio frequency power that is produced by the intentional radiator shall be at least 20 dB below that in the 100 kHz bandwidth within the band that contains the highest level of the desired power, based on either an RF conducted or a radiated measurement, provided the transmitter demonstrates compliance with the peak conducted power limits. In addition, radiated emissions which fall in the restricted bands, as defined in §15.205(a), must also comply with the radiated emission limits specified in 15.209(a) (see Section 15.205(c)).

Test Configuration

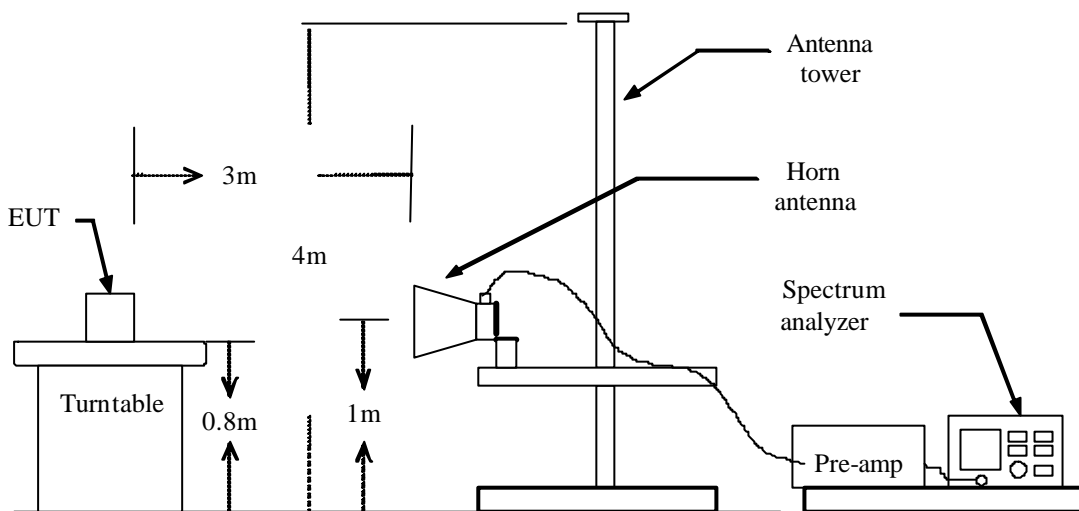

TEST PROCEDURE

1. The EUT is placed on a turntable, which is 0.8m above the ground plane.
2. The turntable shall be rotated for 360 degrees to determine the position of maximum emission level.
3. EUT is set 3m away from the receiving antenna, which is varied from 1m to 4m to find out the highest emission.
4. Set the spectrum analyzer in the following setting in order to capture the lower and upper band-edges of the emission:
 - (a) PEAK: RBW=VBW=1MHz / Sweep=AUTO
 - (b) AVERAGE: RBW=1MHz / VBW=10Hz / Sweep=AUTO
5. Repeat the procedures until all the PEAK and AVERAGE versus POLARIZATION are measured.

TEST RESULTS

Refer to attach spectrum analyzer data chart.



Band Edges (IEEE 802.11b/ CH Low)

Detector mode: Peak

Polarity: Vertical

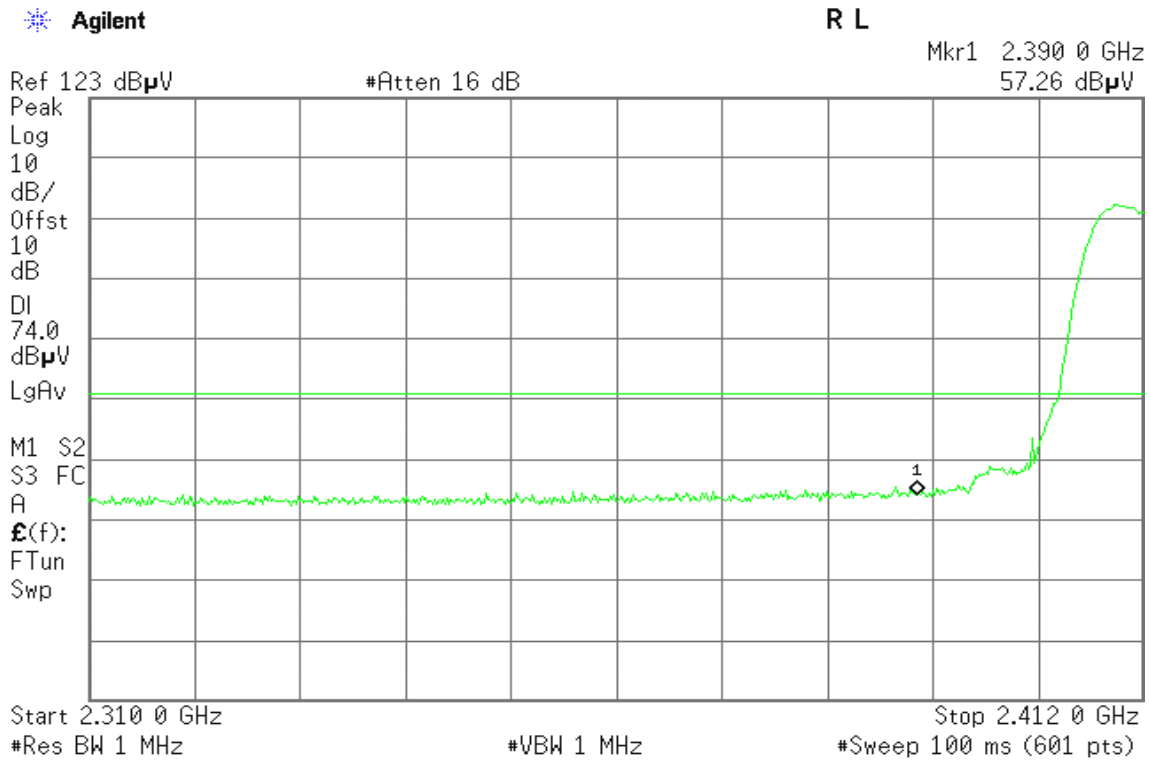

Detector mode: Average

Polarity: Vertical

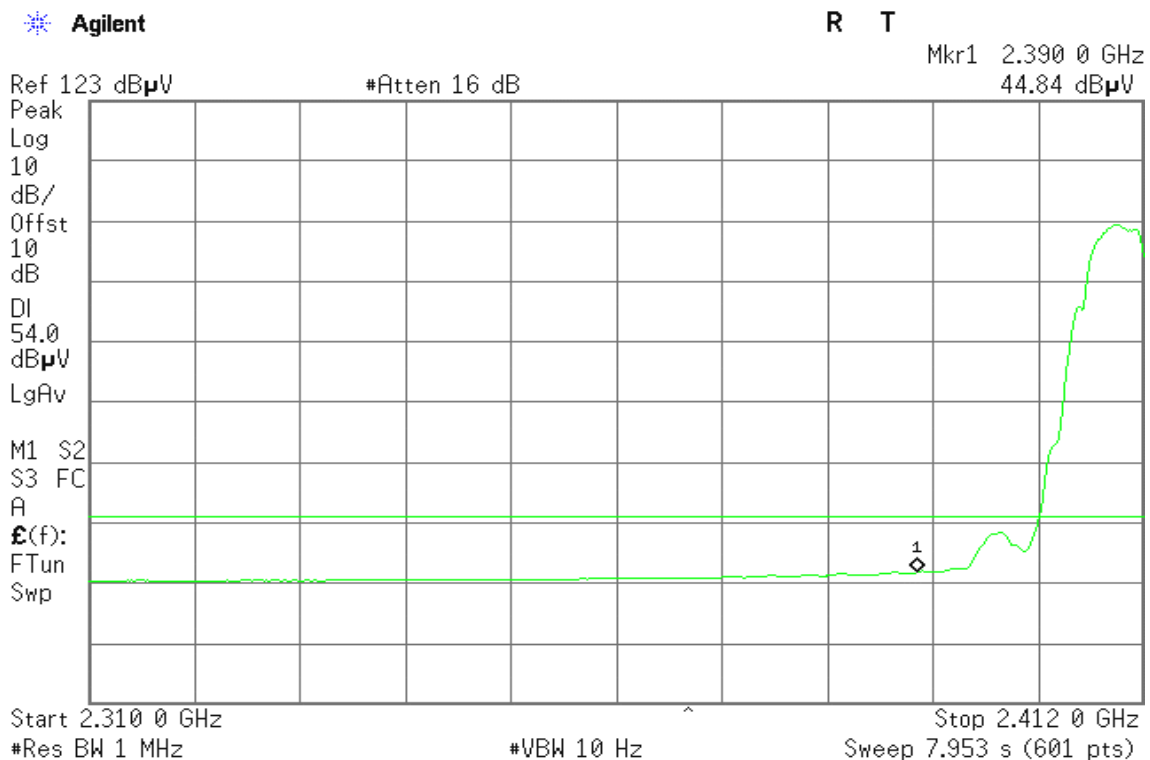



Detector mode: Peak

Polarity: Horizontal

Agilent

R T

Mkr1 2.390 0 GHz
55.94 dBμV

Ref 123 dBμV

#Atten 16 dB

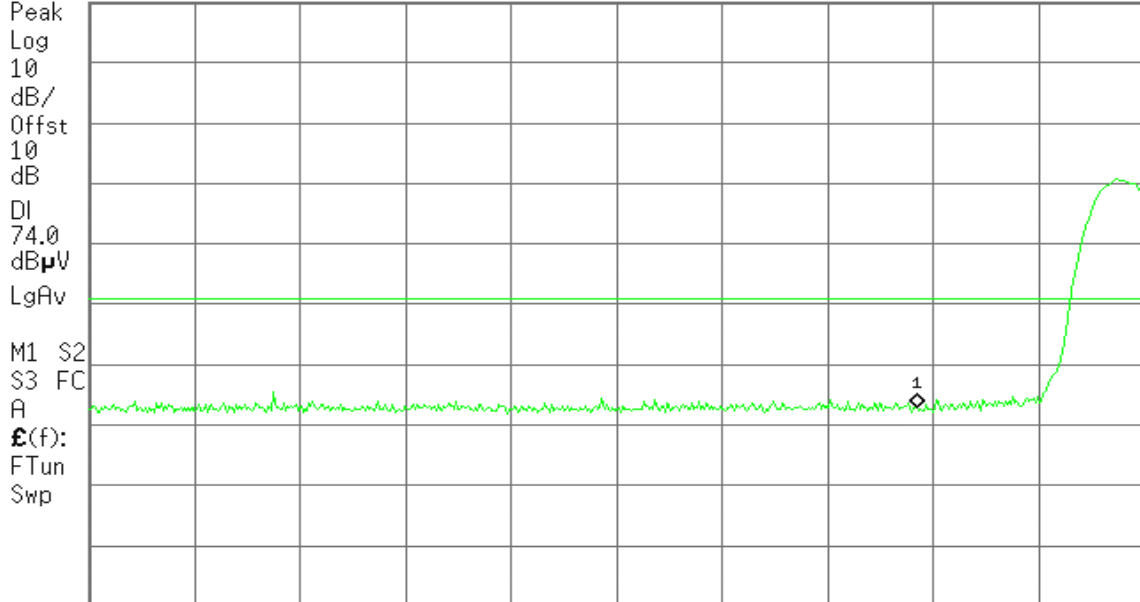

Start 2.310 0 GHz

#Res BW 1 MHz

#VBW 1 MHz

Stop 2.412 0 GHz

#Sweep 100 ms (601 pts)

Detector mode: Average

Polarity: Horizontal

Agilent

R T

Mkr1 2.390 0 GHz
43.43 dBμV

Ref 123 dBμV

#Atten 16 dB



Start 2.310 0 GHz

#Res BW 1 MHz

#VBW 10 Hz

Stop 2.412 0 GHz

Sweep 7.953 s (601 pts)



Band Edges (IEEE 802.11b/ CH High)

Detector mode: Peak

Polarity: Vertical

Agilent

R T

Mkr1 2.483 50 GHz
56.89 dBμV

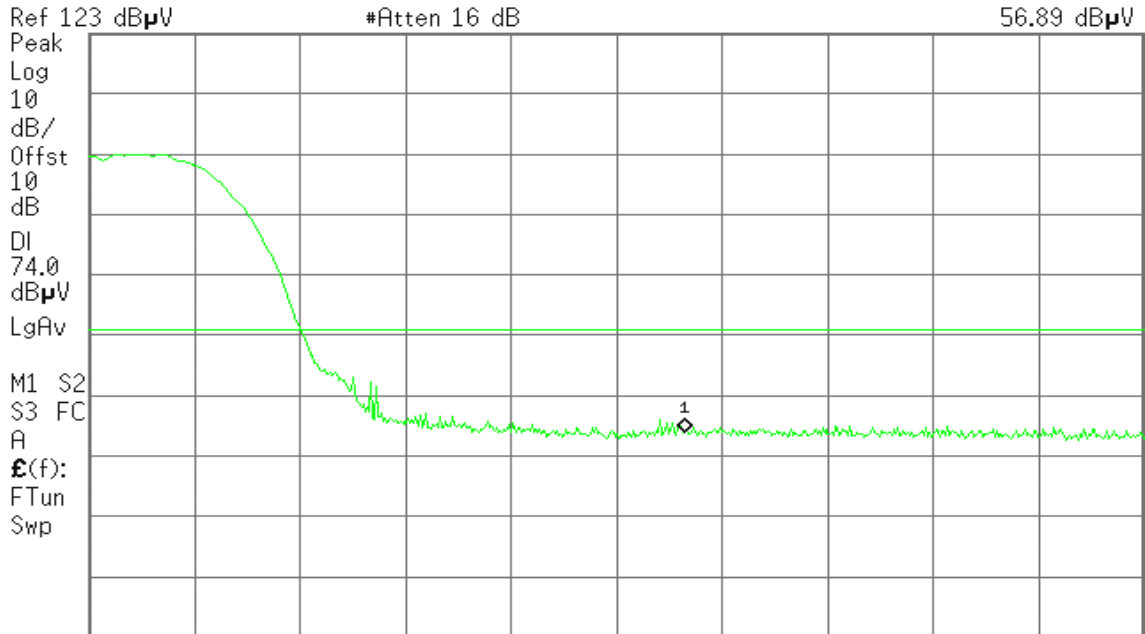

Start 2.462 00 GHz #Res BW 1 MHz #VBW 1 MHz Stop 2.500 00 GHz #Sweep 100 ms (601 pts)

Detector mode: Average

Polarity: Vertical

Agilent

R T

Mkr1 2.483 50 GHz
45.11 dBμV

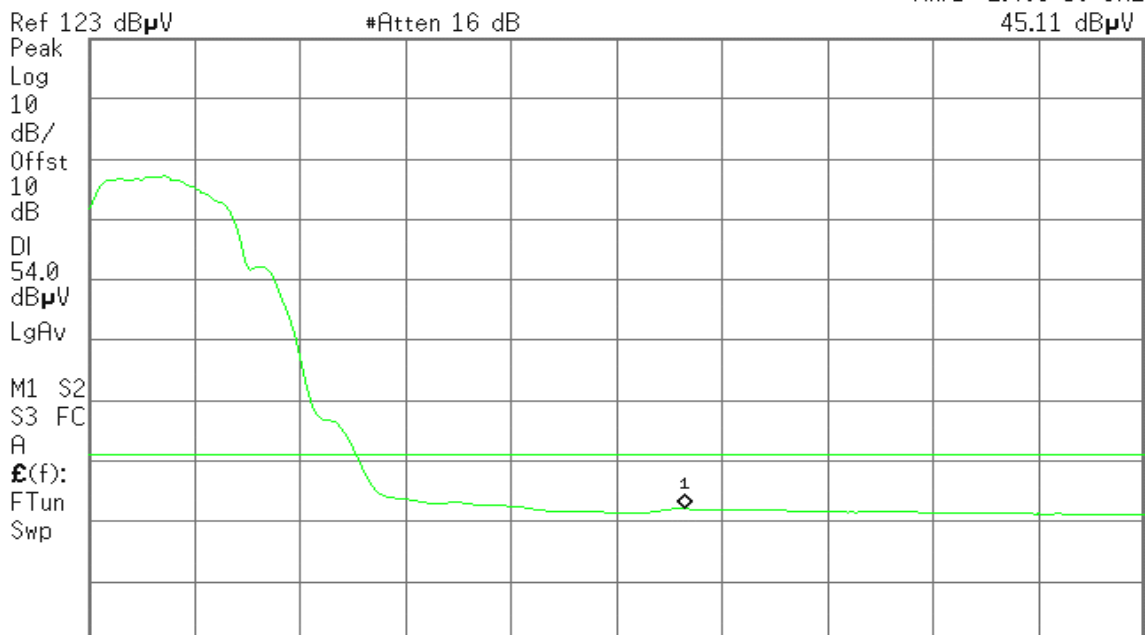

Start 2.462 00 GHz #Res BW 1 MHz #VBW 10 Hz Stop 2.500 00 GHz Sweep 2.963 s (601 pts)



Detector mode: Peak

Polarity: Horizontal

Agilent

R T

Mkr1 2.483 50 GHz
56.81 dBμV

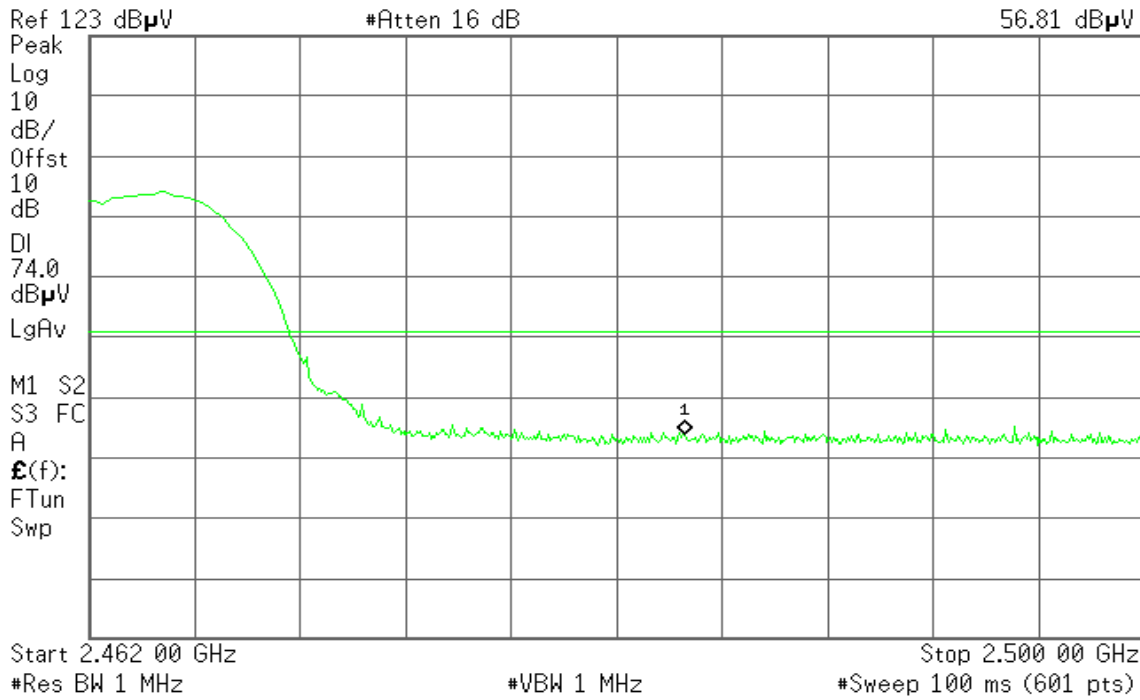

Detector mode: Average

Polarity: Horizontal

Agilent

R T

Mkr1 2.483 50 GHz
44.21 dBμV

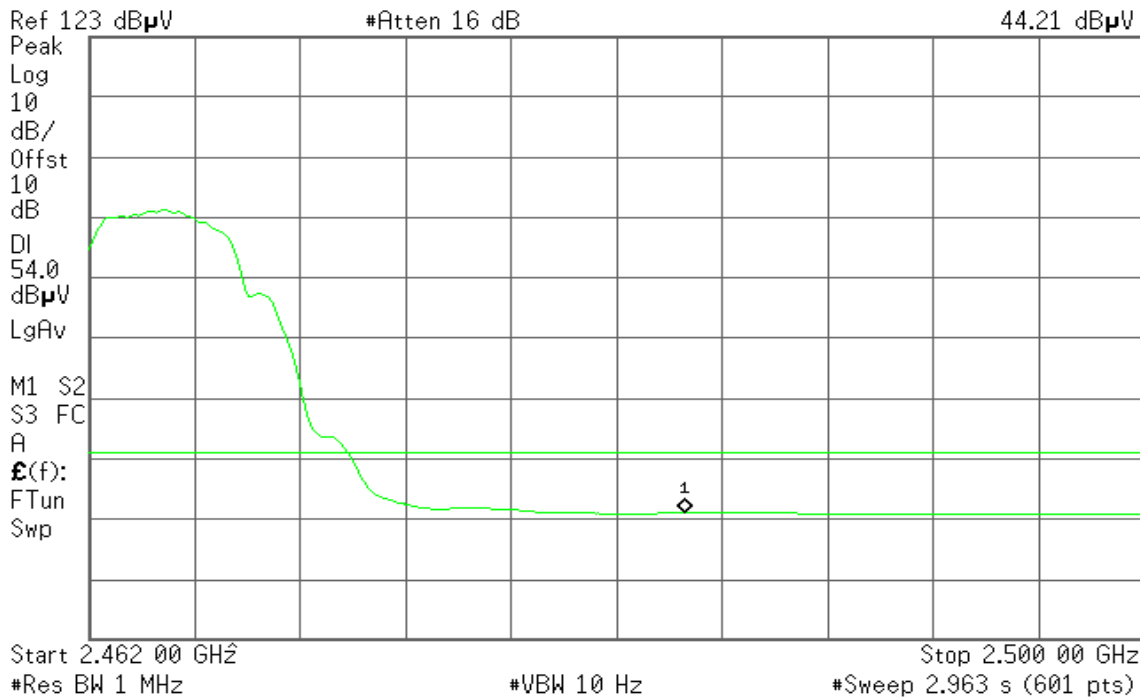



Band Edges (IEEE 802.11g / CH Low)

Detector mode: Peak

Polarity: Vertical

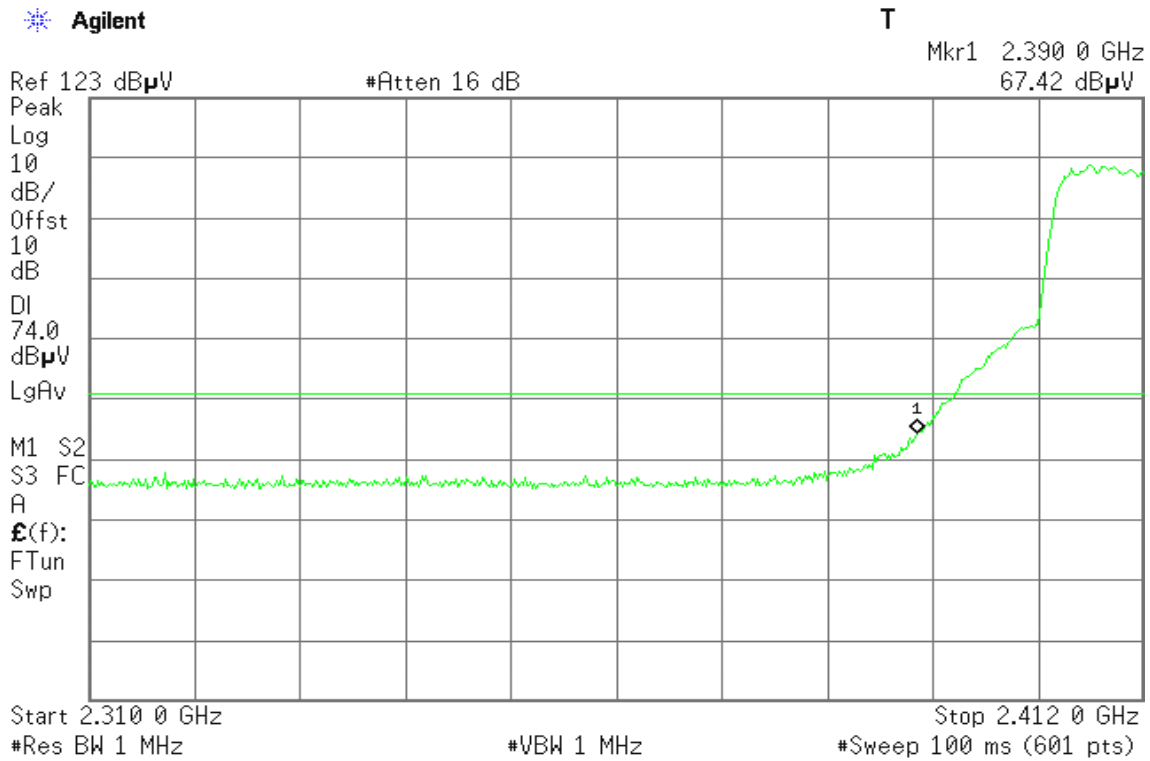

Detector mode: Average

Polarity: Vertical

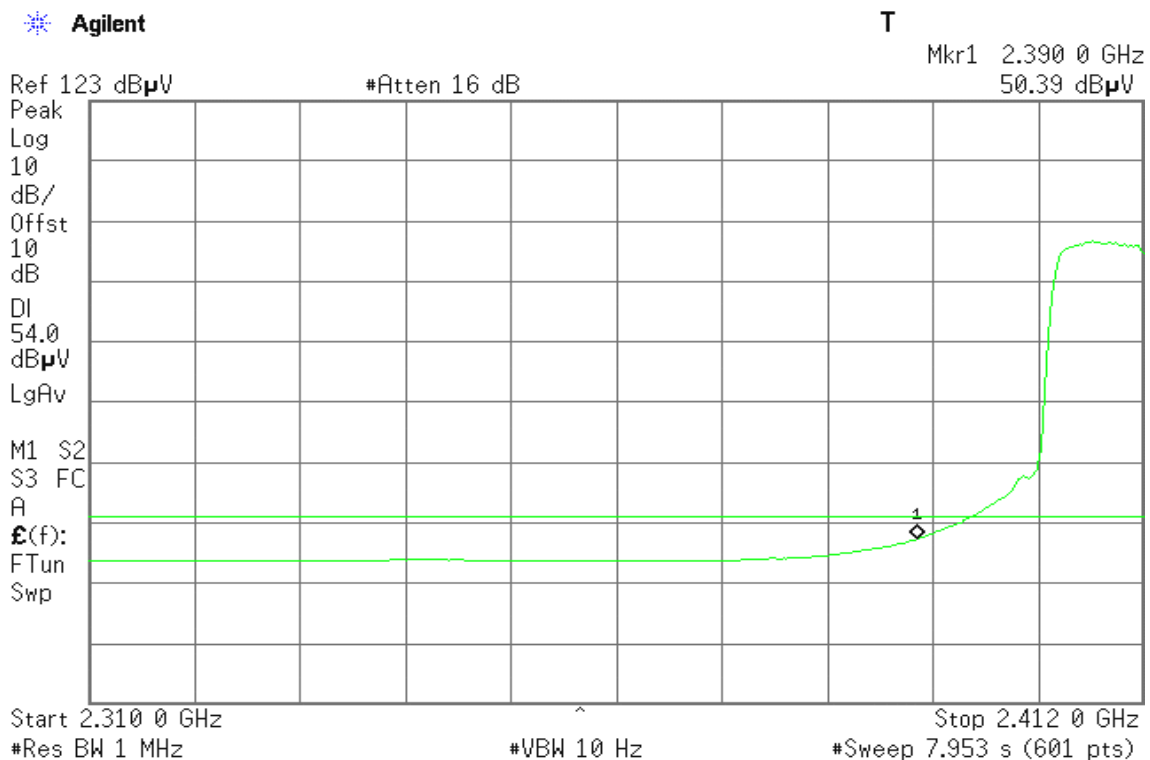



Detector mode: Peak

Polarity: Horizontal

Agilent

T

Mkr1 2.390 0 GHz
58.73 dBμV

Ref 123 dBμV

#Atten 16 dB

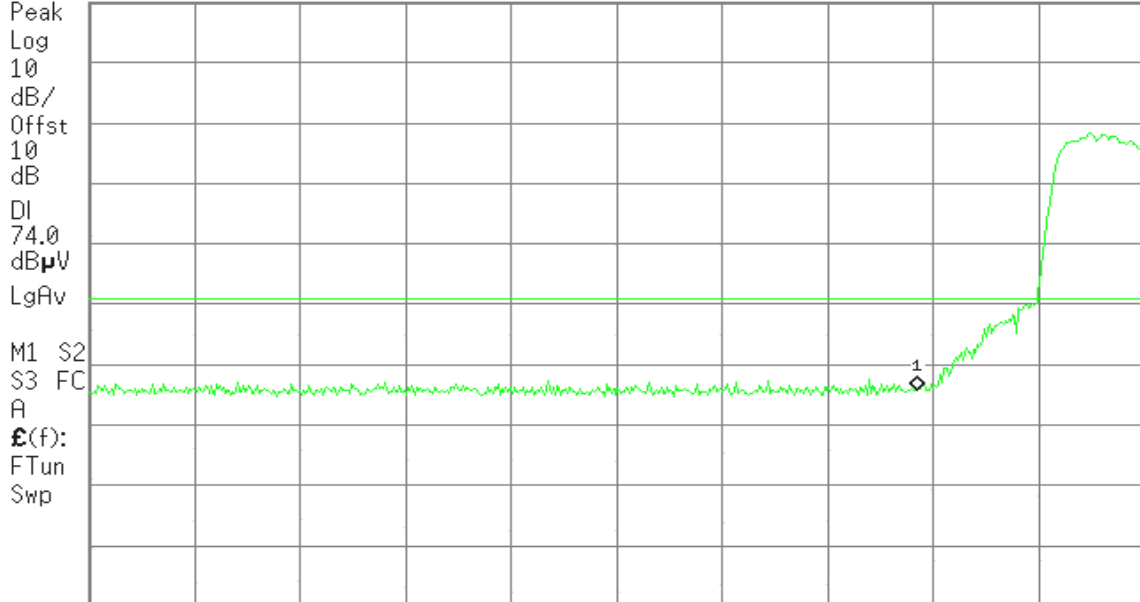

Start 2.310 0 GHz

#Res BW 1 MHz

#VBW 1 MHz

Stop 2.412 0 GHz

#Sweep 100 ms (601 pts)

Detector mode: Average

Polarity: Horizontal

Agilent

T

Mkr1 2.390 0 GHz
46.71 dBμV

Ref 123 dBμV

#Atten 16 dB



Start 2.310 0 GHz

#Res BW 1 MHz

#VBW 10 Hz

Stop 2.412 0 GHz

Sweep 7.953 s (601 pts)



Band Edges (IEEE 802.11g / CH High)

Detector mode: Peak

Polarity: Vertical

Agilent

R T

Mkr1 2.483 50 GHz
65.72 dB μ V

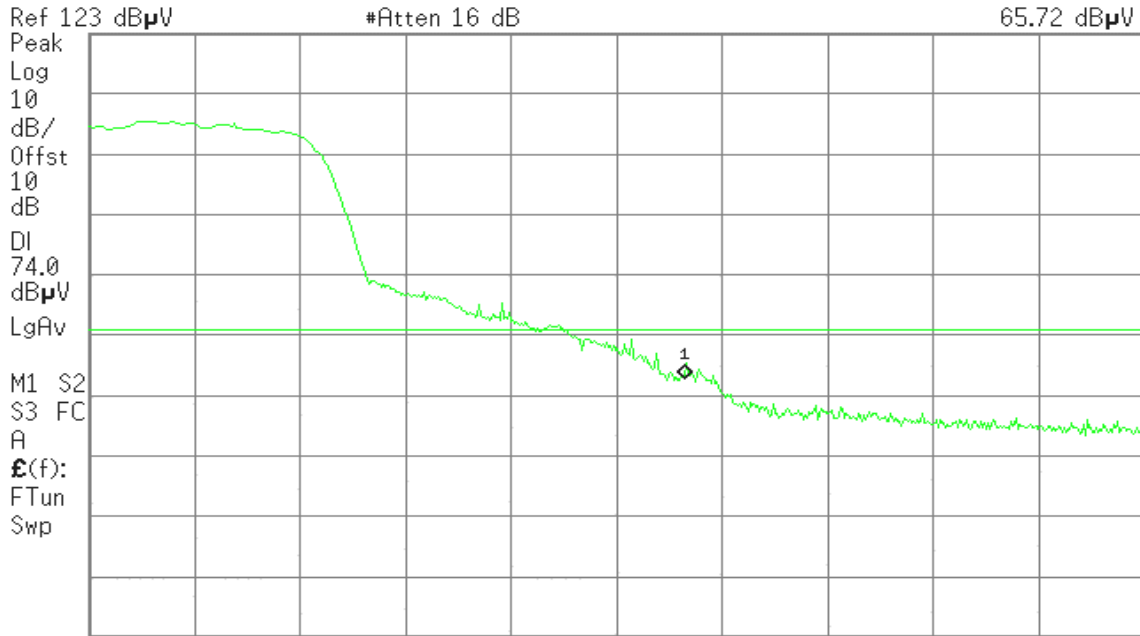

Start 2.462 00 GHz #Res BW 1 MHz #VBW 1 MHz Stop 2.500 00 GHz #Sweep 100 ms (601 pts)

Detector mode: Average

Polarity: Vertical

Agilent

R T

Mkr1 2.483 50 GHz
49.09 dB μ V

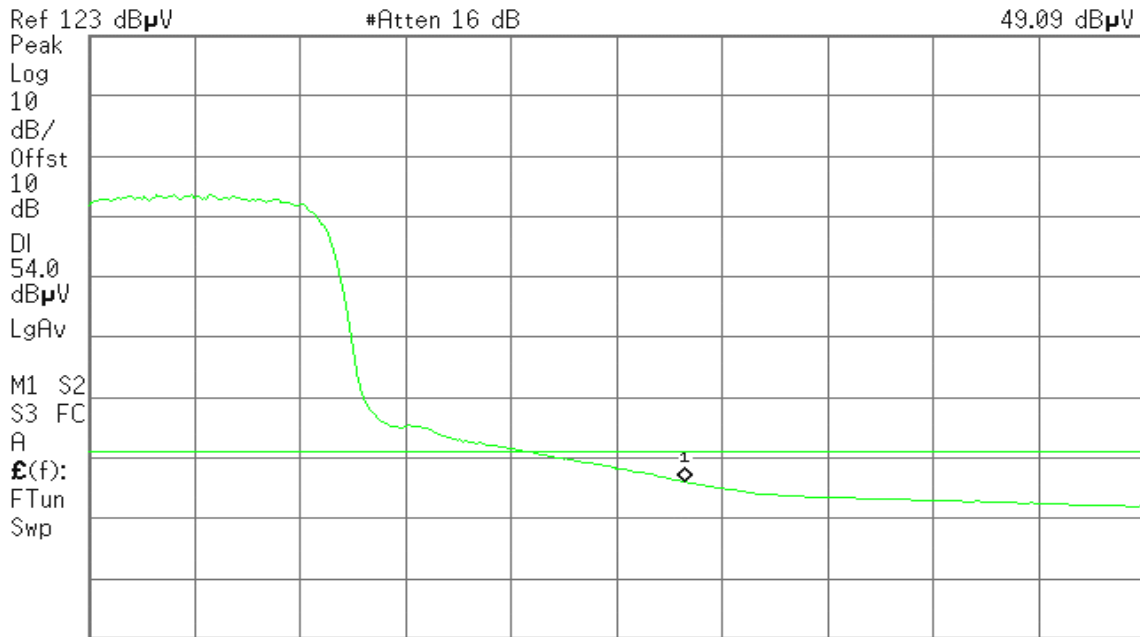

Start 2.462 00 GHz #Res BW 1 MHz #VBW 10 Hz Stop 2.500 00 GHz Sweep 2.963 s (601 pts)



Detector mode: Peak

Polarity: Horizontal

Agilent

R T

Mkr1 2.483 50 GHz
60.13 dBμV

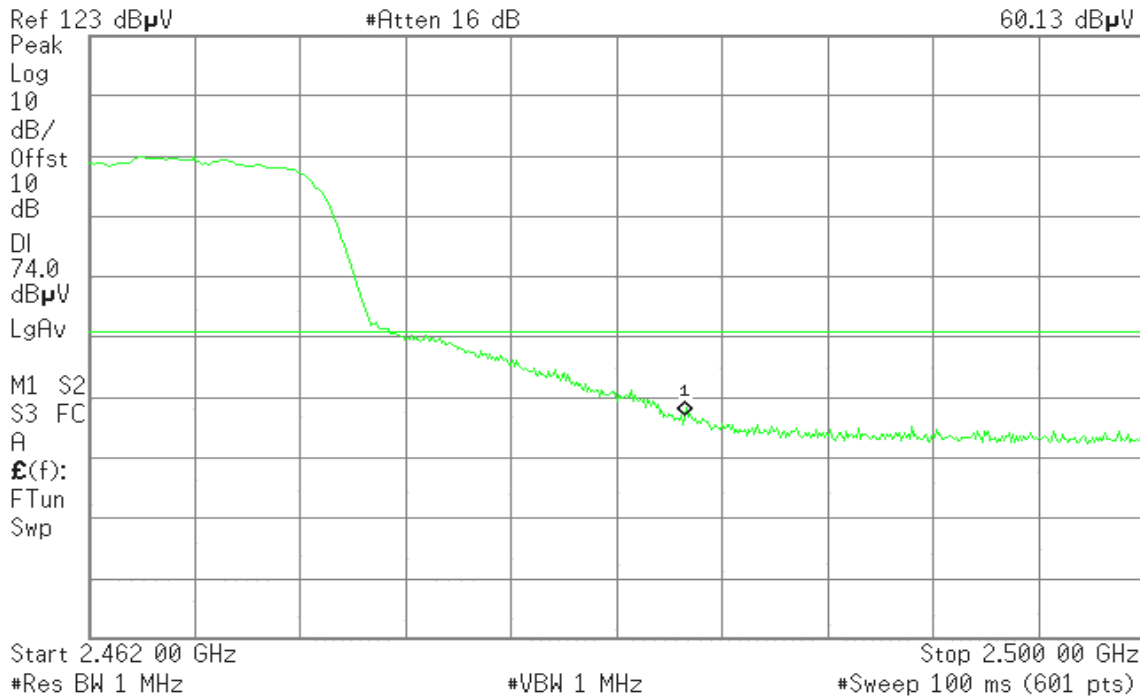

Detector mode: Average

Polarity: Horizontal

Agilent

R T

Mkr1 2.483 50 GHz
45.36 dBμV

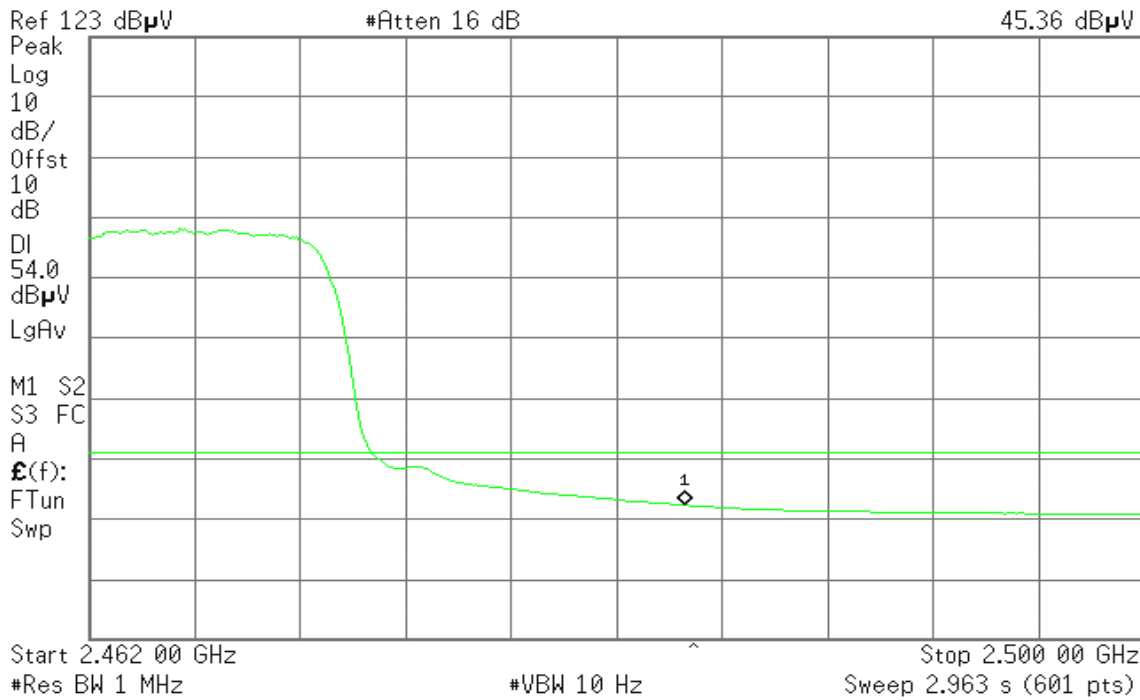

7.5 PEAK POWER SPECTRAL DENSITY

LIMIT

1. According to §15.247(e), for digitally modulated systems, the power spectral density conducted from the intentional radiator to the antenna shall not be greater than 8 dBm in any 3 kHz band during any time interval of continuous transmission.
2. According to §15.247(f), the digital modulation operation of the hybrid system, with the frequency hopping turned off, shall comply with the power density requirements of paragraph (d) of this section.

Test Configuration

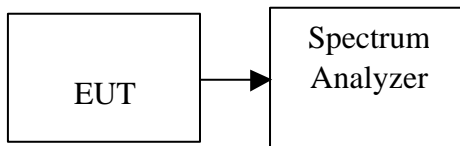

TEST PROCEDURE

1. Place the EUT on the table and set it in transmitting mode.
Remove the antenna from the EUT and then connect a low loss RF cable from the antenna port to the spectrum analyzer.
2. Set the spectrum analyzer as RBW = 3kHz, VBW = 10kHz, Span = 300kHz, Sweep=100s
3. Record the max. reading.
4. Repeat the above procedure until the measurements for all frequencies are completed.

TEST RESULTS

No non-compliance noted.



Test Data

Test mode: IEEE 802.11b

Channel	Frequency (MHz)	PPSD (dBm)	Limit (dBm)	Result
Low	2412	-7.54	8.00	PASS
Mid	2437	-8.52		PASS
High	2462	-12.97		PASS

Test mode: IEEE 802.11g

Channel	Frequency (MHz)	PPSD (dBm)	Limit (dBm)	Result
Low	2412	-10.21	8.00	PASS
Mid	2437	-10.81		PASS
High	2462	-10.29		PASS



Test Plot

IEEE 802.11b

PPSD (CH Low)

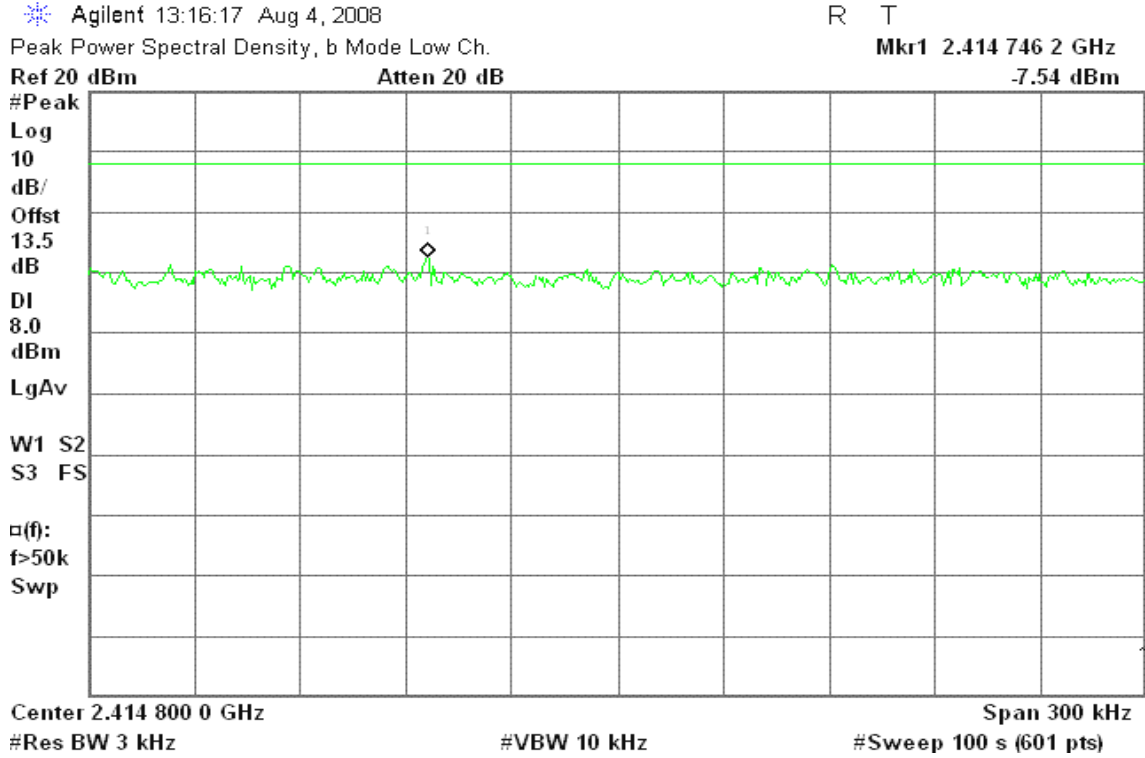

PPSD (CH Mid)

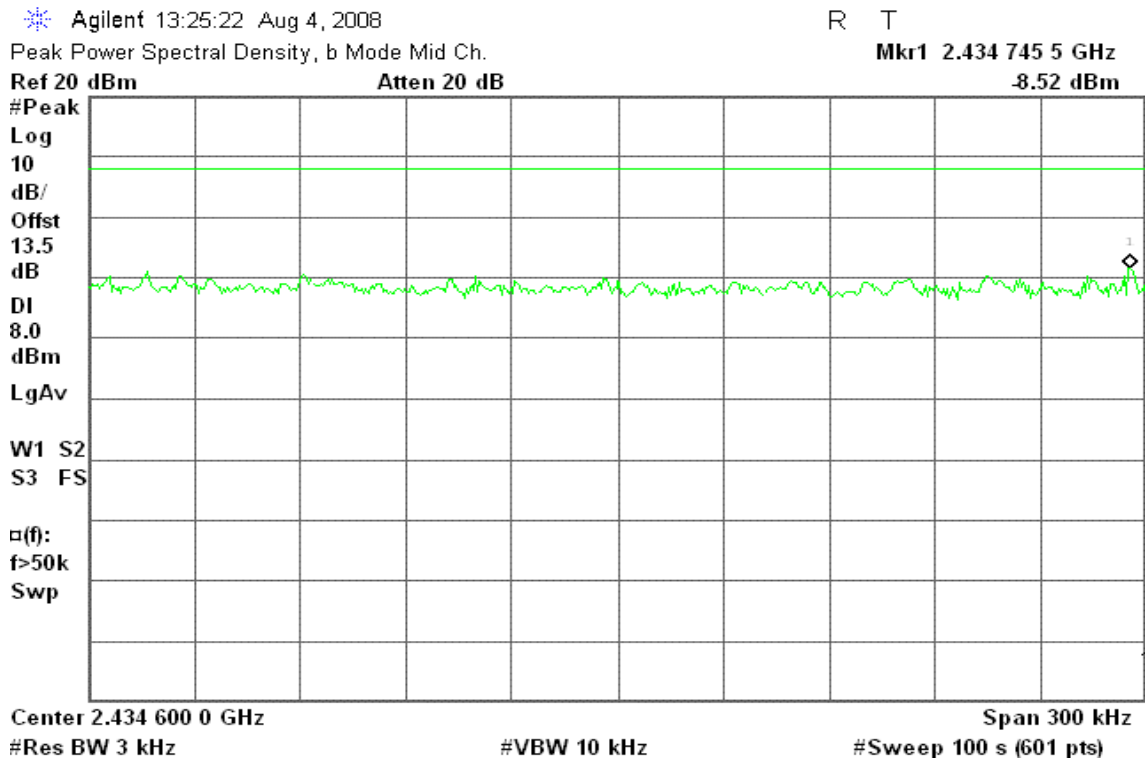



PPSD (CH High)

Agilent 13:34:54 Aug 4, 2008

R T

Peak Power Spectral Density, b Mode High Ch.

Mkr1 2.461 369 9 GHz

Ref 20 dBm

Atten 20 dB

-12.97 dBm

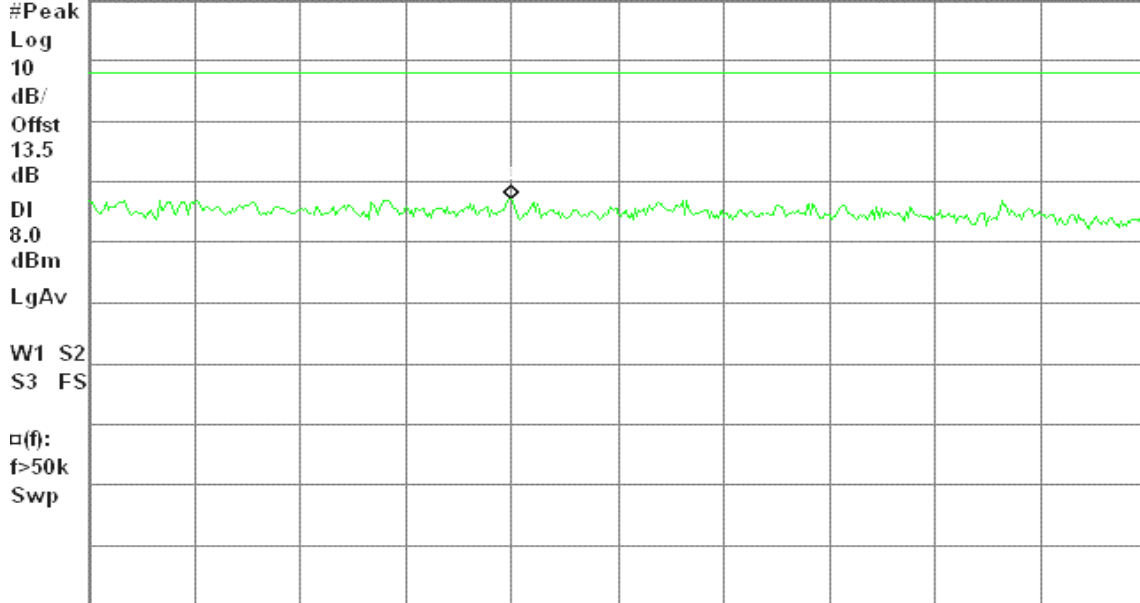

Center 2.461 400 0 GHz

Span 300 kHz

#Res BW 3 kHz

#VBW 10 kHz

#Sweep 100 s (601 pts)

IEEE 802.11g

PPSD (CH Low)

Agilent 13:47:45 Aug 4, 2008

R T

Peak Power Spectral Density, g Mode Low Ch.

Mkr1 2.416 091 0 GHz

Ref 20 dBm

Atten 20 dB

-10.21 dBm

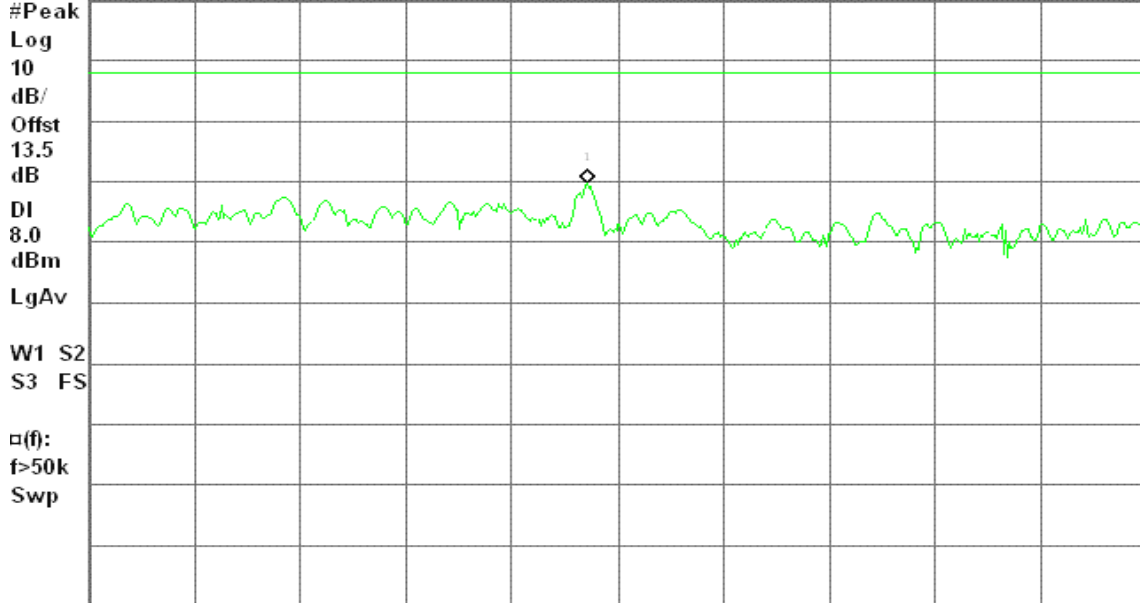

Center 2.416 100 0 GHz

Span 300 kHz

#Res BW 3 kHz

#VBW 10 kHz

#Sweep 100 s (601 pts)



PPSD (CH Mid)

Agilent 13:58:08 Aug 4, 2008

R T

Peak Power Spectral Density, g Mode Mid Ch.

Mkr1 2.433 538 5 GHz

Ref 20 dBm

Atten 20 dB

-10.81 dBm

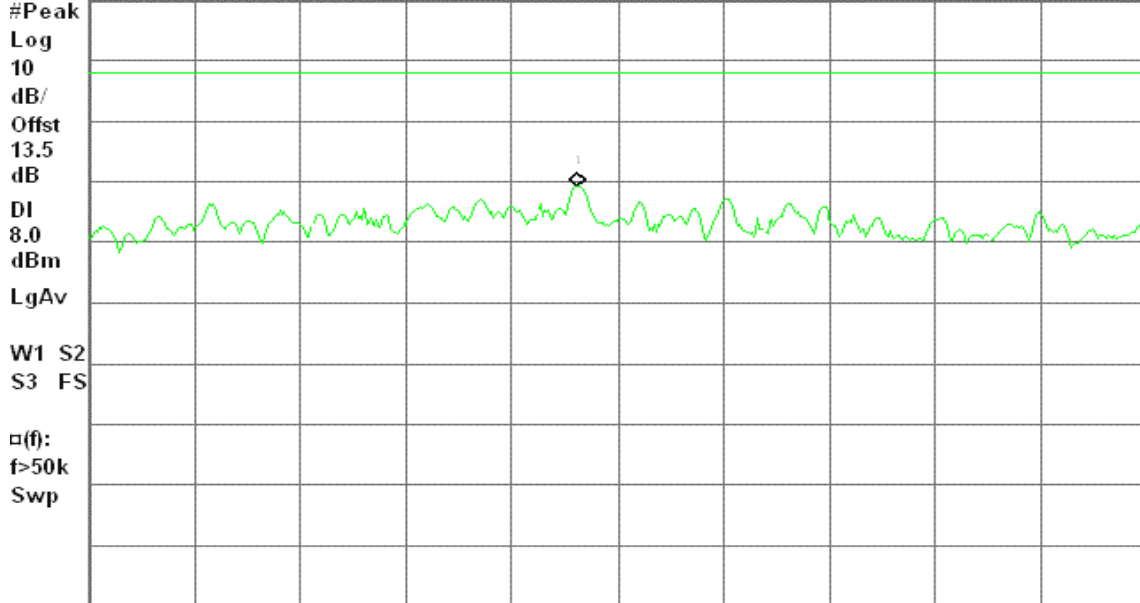

Center 2.433 550 0 GHz

Span 300 kHz

#Res BW 3 kHz

#VBW 10 kHz

#Sweep 100 s (601 pts)

PPSD (CH High)

Agilent 14:07:17 Aug 4, 2008

R T

Peak Power Spectral Density, g Mode High Ch.

Mkr1 2.466 090 0 GHz

Ref 20 dBm

Atten 20 dB

-10.29 dBm

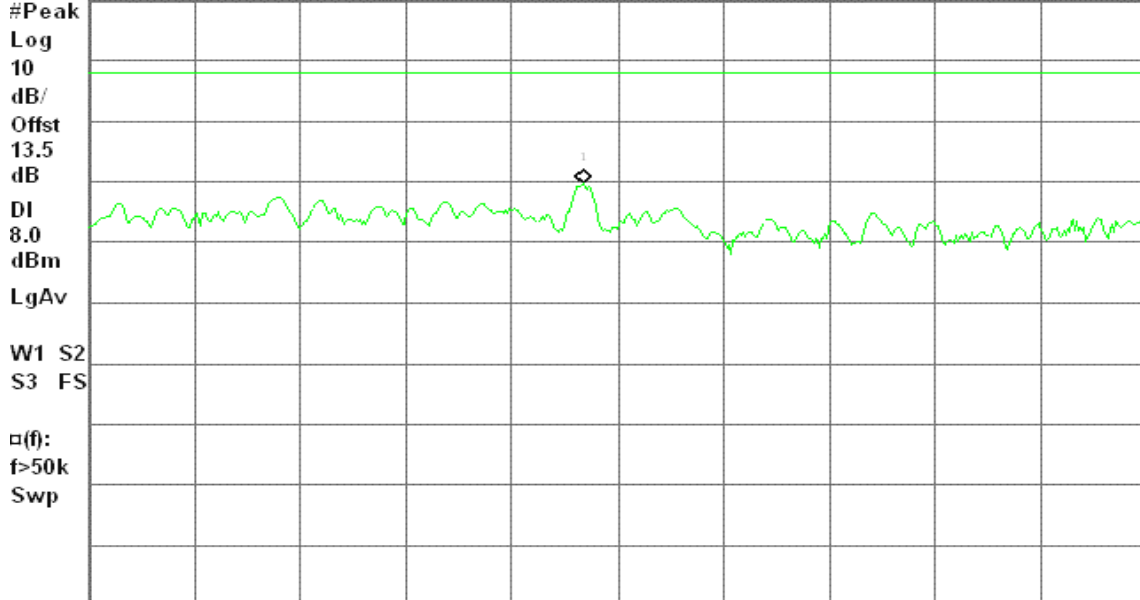

Center 2.466 100 0 GHz

Span 300 kHz

#Res BW 3 kHz

#VBW 10 kHz

#Sweep 100 s (601 pts)



7.6 SPURIOUS EMISSIONS

7.6.1 Conducted Measurement

LIMIT

According to §15.247(d), in any 100 kHz bandwidth outside the frequency bands in which the spread spectrum intentional radiator is operating, the radio frequency power that is produced by the intentional radiator shall be at least 20 dB below that in the 100 kHz bandwidth within the band that contains the highest level of the desired power, based on either an RF conducted or a radiated measurement, provided the transmitter demonstrates compliance with the peak conducted power limits. In addition, radiated emissions which fall in the restricted bands, as defined in §15.205(a), must also comply with the radiated emission limits specified in 15.209(a) (see Section 15.205(c)).

Test Configuration

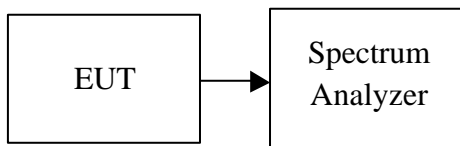

TEST PROCEDURE

Conducted RF measurements of the transmitter output were made to confirm that the EUT antenna port conducted emissions meet the specified limit and to identify any spurious signals that require further investigation or measurements on the radiated emissions site.

The transmitter output is connected to the spectrum analyzer. The resolution bandwidth is set to 100 kHz. The video bandwidth is set to 100 kHz.

Measurements are made over the 30MHz to 26GHz range with the transmitter set to the lowest, middle, and highest channels.

TEST RESULTS

No non-compliance noted.



Test Plot

IEEE 802.11b

CH Low

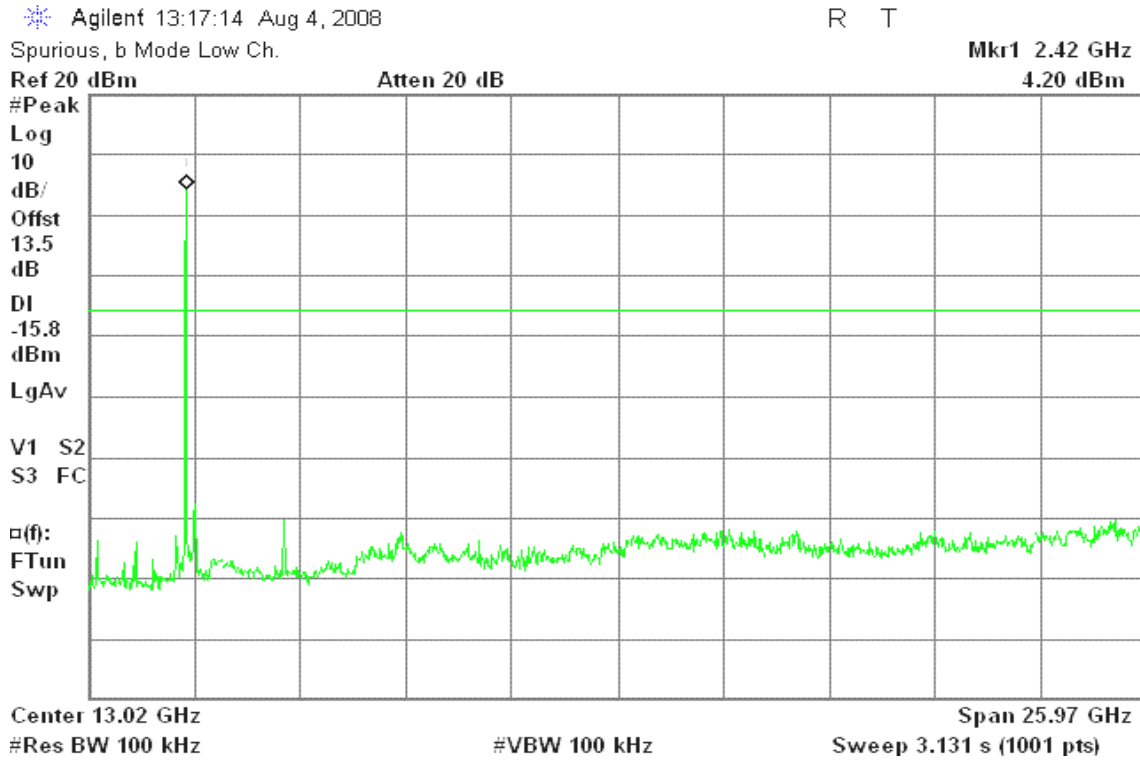

CH Mid

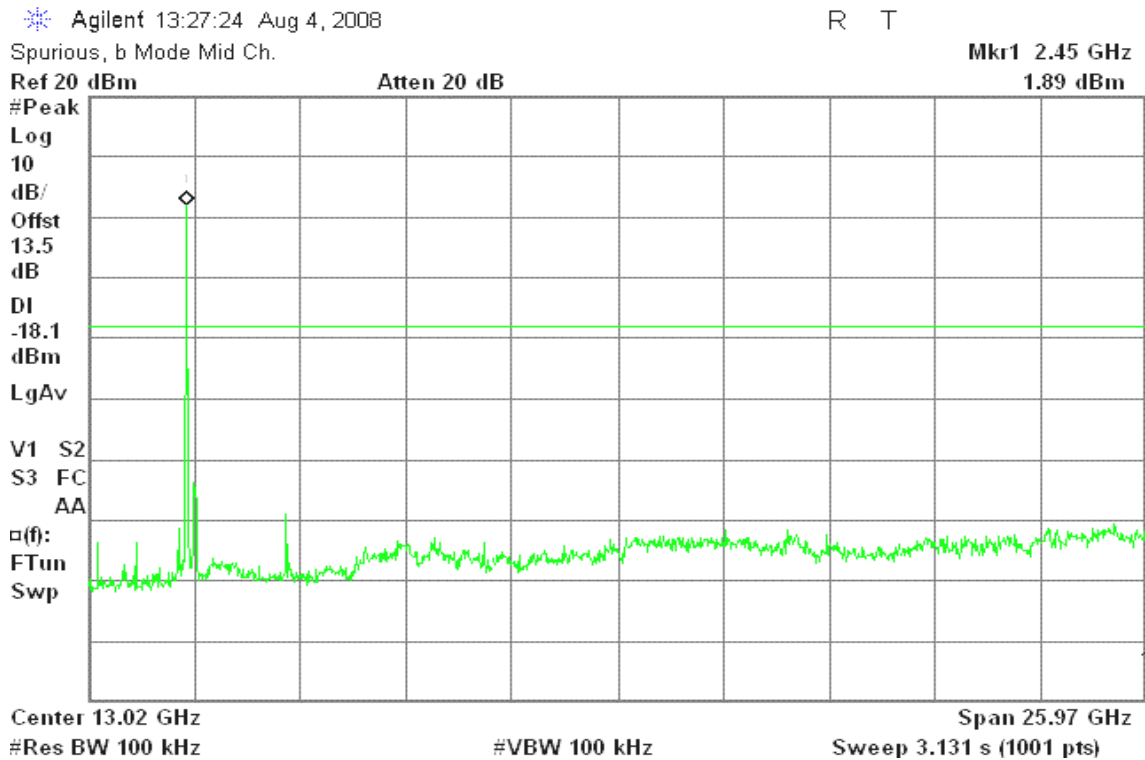



CH High

Agilent 13:35:44 Aug 4, 2008

R T

Spurious, b Mode High Ch.

Mkr1 2.45 GHz

Ref 20 dBm

Atten 20 dB

-1.46 dBm

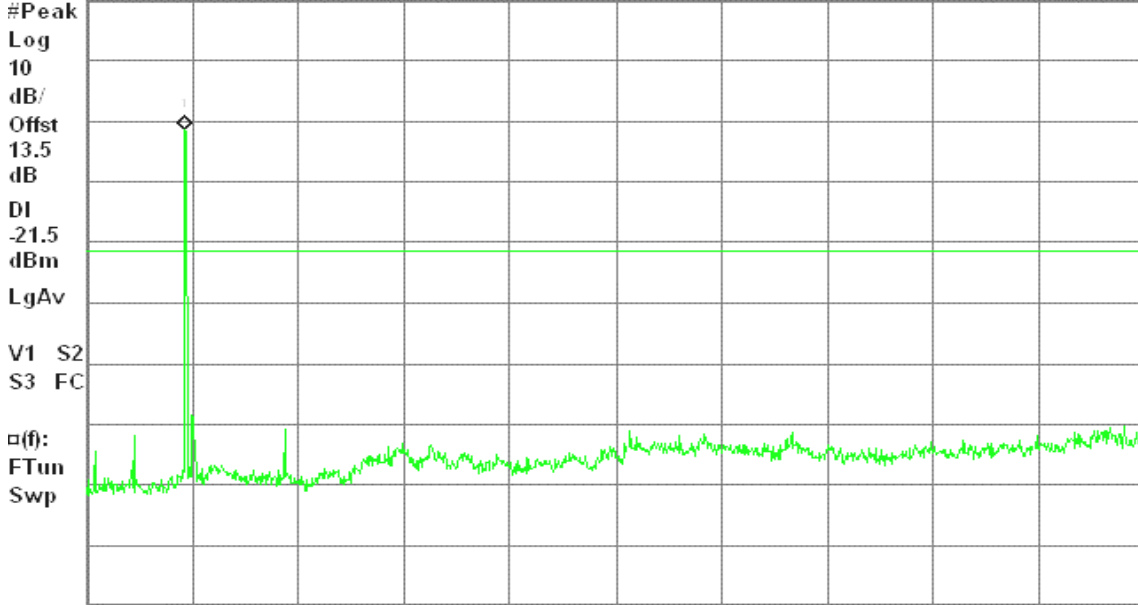

Center 13.02 GHz

Span 25.97 GHz

#Res BW 100 kHz

#VBW 100 kHz

Sweep 3.131 s (1001 pts)

IEEE 802.11g

CH Low

Agilent 13:48:50 Aug 4, 2008

R T

Spurious, g Mode Low Ch.

Mkr1 2.42 GHz

Ref 20 dBm

Atten 20 dB

1.35 dBm

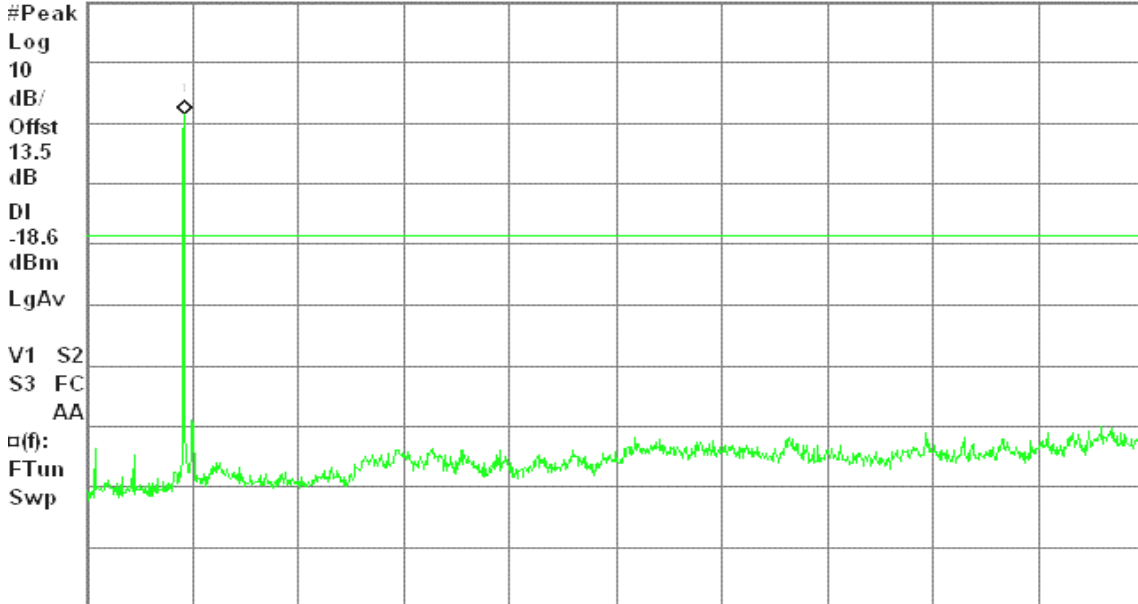

Center 13.02 GHz

Span 25.97 GHz

#Res BW 100 kHz

#VBW 100 kHz

Sweep 3.131 s (1001 pts)



CH Mid

Agilent 13:59:34 Aug 4, 2008

R T

Spurious, g Mode Mid Ch.

Mkr1 2.45 GHz

Ref 20 dBm

Atten 20 dB

-1.15 dBm

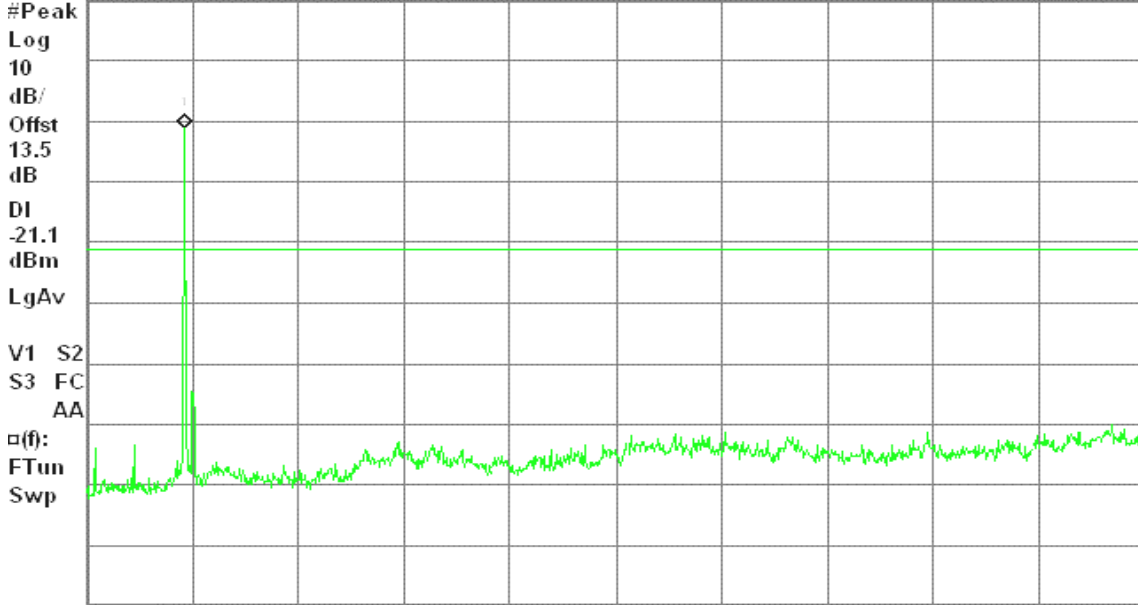

Center 13.02 GHz

Span 25.97 GHz

#Res BW 100 kHz

#VBW 100 kHz

Sweep 3.131 s (1001 pts)

CH High

Agilent 14:08:20 Aug 4, 2008

R T

Spurious, g Mode High Ch.

Mkr1 2.45 GHz

Ref 20 dBm

Atten 20 dB

-0.88 dBm

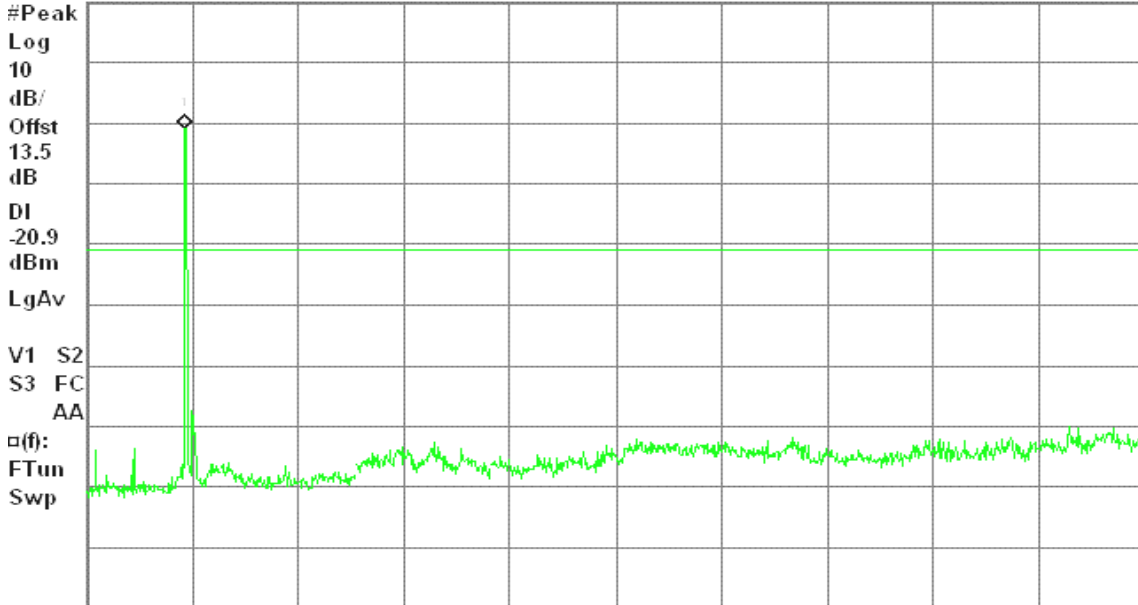

Center 13.02 GHz

Span 25.97 GHz

#Res BW 100 kHz

#VBW 100 kHz

Sweep 3.131 s (1001 pts)



7.6.2 Radiated Emissions

LIMIT

1. According to §15.209(a), except as provided elsewhere in this Subpart, the emissions from an intentional radiator shall not exceed the field strength levels specified in the following table:

Frequency (MHz)	Field Strength (µV/m)	Measurement Distance (m)
30-88	100*	3
88-216	150*	3
216-960	200*	3
Above 960	500	3

Remark: Except as provided in paragraph (g), fundamental emissions from intentional radiators operating under this Section shall not be located in the frequency bands 54-72 MHz, 76-88 MHz, 174-216 MHz or 470-806 MHz. However, operation within these frequency bands is permitted under other sections of this Part, e.g., Sections 15.231 and 15.241.

2. In the emission table above, the tighter limit applies at the band edges.

Frequency (MHz)	Field Strength (µV/m at 3-meter)	Field Strength (dBµV/m at 3-meter)
30-88	100	40
88-216	150	43.5
216-960	200	46
Above 960	500	54

Test Configuration

Below 1 GHz

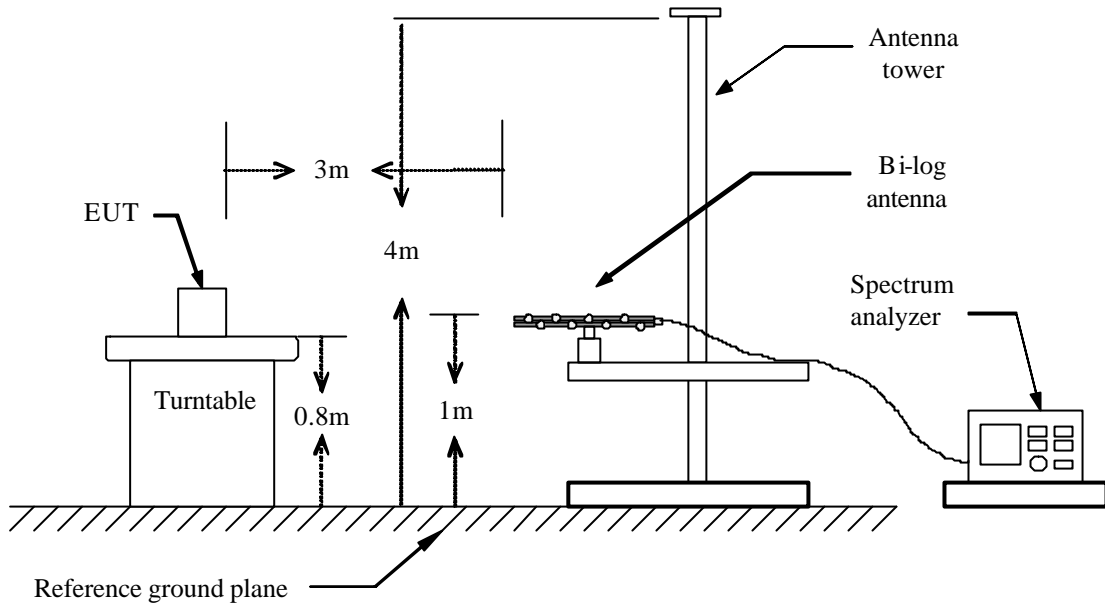

Above 1 GHz

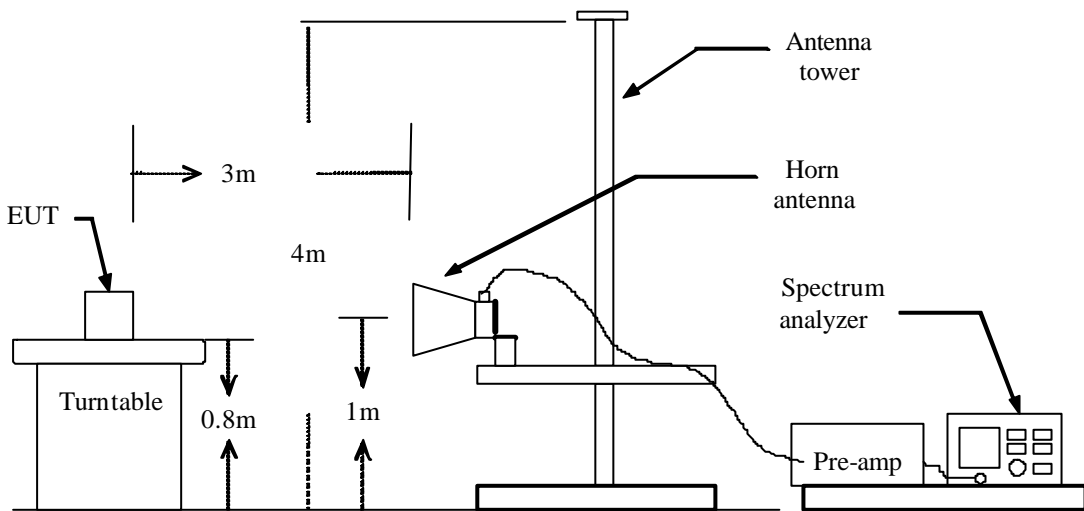



TEST PROCEDURE

1. The EUT is placed on a turntable, which is 0.8m above ground plane.
2. The turntable shall be rotated for 360 degrees to determine the position of maximum emission level.
3. EUT is set 3m away from the receiving antenna, which is varied from 1m to 4m to find out the highest emissions.
4. Maximum procedure was performed on the six highest emissions to ensure EUT compliance.
5. And also, each emission was to be maximized by changing the polarization of receiving antenna both horizontal and vertical.
6. Set the spectrum analyzer in the following setting as:
Below 1GHz:
RBW=100kHz / VBW=300kHz / Sweep=AUTO
Above 1GHz:
(a) PEAK: RBW=VBW=1MHz / Sweep=AUTO
(b) AVERAGE: RBW=1MHz / VBW=10Hz / Sweep=AUTO
7. Repeat above procedures until the measurements for all frequencies are complete.

TEST RESULTS

No non-compliance noted.

**Below 1 GHz****Operation Mode:** Normal Link**Test Date:** July 30, 2008**Temperature:** 20°C**Tested by:** Jerry Lin**Humidity:** 50 % RH**Polarity:** Ver. / Hor.

Frequency (MHz)	Ant.Pol. (H/V)	Reading (dBuV)	Correction Factor (dB/m)	Result (dBuV/m)	Limit (dBuV/m)	Margin (dB)	Remark
120.53	V	47.62	-7.85	39.76	43.50	-3.74	Peak
240.17	V	50.80	-7.87	42.93	46.00	-3.07	Peak
479.43	V	41.47	-1.33	40.14	46.00	-5.86	Peak
542.48	V	40.22	0.56	40.79	46.00	-5.21	Peak
600.68	V	37.92	1.27	39.19	46.00	-6.81	Peak
749.42	V	34.05	4.31	38.36	46.00	-7.64	Peak
240.17	H	50.38	-7.87	42.51	46.00	-3.49	Peak
359.80	H	44.38	-4.61	39.76	46.00	-6.24	Peak
479.43	H	38.56	-1.33	37.23	46.00	-8.77	Peak
542.48	H	39.14	0.56	39.70	46.00	-6.30	Peak
720.32	H	35.88	3.25	39.13	46.00	-6.87	Peak
839.95	H	33.91	5.37	39.28	46.00	-6.72	Peak

Remark:

1. *Measuring frequencies from 30 MHz to the 1GHz.*
2. *Radiated emissions measured in frequency range from 30 MHz to 1000MHz were made with an instrument using peak/quasi-peak detector mode.*
3. *Quasi-peak test would be performed if the peak result were greater than the quasi-peak limit or as required by the applicant.*
4. *Measurements above show only up to 6 maximum emissions noted, or would be lesser, with " N/A " remark, if no specific emissions from the EUT are recorded (ie: margin>20dB from the applicable limit) and considered that's already beyond the background noise floor.*
5. *Margin (dB) = Remark result (dBuV/m) – Quasi-peak limit (dBuV/m).*

**Above 1 GHz****Operation Mode:** IEEE 802.11b / TX / CH Low**Test Date:** July 29, 2008**Temperature:** 25°C**Tested by:** Jerry Lin**Humidity:** 50 % RH**Polarity:** Ver. / Hor.

Frequency (MHz)	Ant.Pol. (H/V)	Reading (Peak) (dBuV)	Reading (Average) (dBuV)	Correction Factor (dB/m)	Result (Peak) (dBuV/m)	Result (Average) (dBuV/m)	Limit (Peak) (dBuV/m)	Limit (Average) (dBuV/m)	Margin (dB)	Remark
2653.33	V	60.68	54.80	-2.23	58.46	52.57	74.00	54.00	-1.43	AVG
3216.67	V	48.75	---	-0.91	47.84	---	74.00	54.00	-6.16	Peak
4825.00	V	56.00	52.36	0.35	56.35	52.71	74.00	54.00	-1.29	AVG
7233.33	V	49.33	---	2.96	52.30	---	74.00	54.00	-1.70	Peak
N/A										
2653.33	H	57.79	54.12	-2.23	55.57	51.89	74.00	54.00	-2.11	AVG
3216.67	H	51.62	---	-0.91	50.71	---	74.00	54.00	-3.29	Peak
4825.00	H	51.85	---	0.35	52.19	---	74.00	54.00	-1.81	Peak
7233.33	H	45.76	---	2.96	48.72	---	74.00	54.00	-5.28	Peak
N/A										

Remark:

1. *Measuring frequencies from 1 GHz to the 10th harmonic of highest fundamental frequency.*
2. *Radiated emissions measured in frequency above 1000MHz were made with an instrument using peak/average detector mode.*
3. *Average test would be performed if the peak result were greater than the average limit or as required by the applicant.*
4. *Data of measurement within this frequency range shown " --- " in the table above means the reading of emissions are attenuated more than 20dB below the permissible limits or the field strength is too small to be measured.*
5. *Measurements above show only up to 6 maximum emissions noted, or would be lesser, with " N/A " remark, if no specific emissions from the EUT are recorded (ie: margin>20dB from the applicable limit) and considered that's already beyond the background noise floor.*
6. *Margin (dB) = Remark result (dBuV/m) – Average limit (dBuV/m).*

**Operation Mode:** IEEE 802.11b / TX / CH Mid**Test Date:** July 29, 2008**Temperature:** 25°C**Tested by:** Jerry Lin**Humidity:** 50 % RH**Polarity:** Ver. / Hor.

Frequency (MHz)	Ant.Pol. (H/V)	Reading (Peak) (dBuV)	Reading (Average) (dBuV)	Correction Factor (dB/m)	Result (Peak) (dBuV/m)	Result (Average) (dBuV/m)	Limit (Peak) (dBuV/m)	Limit (Average) (dBuV/m)	Margin (dB)	Remark
1666.67	V	57.99	---	-6.97	51.03	---	74.00	54.00	-2.97	Peak
2636.67	V	58.28	52.60	-2.27	56.01	50.33	74.00	54.00	-3.67	AVG
2680.00	V	61.56	54.98	-2.15	59.40	52.83	74.00	54.00	-1.17	AVG
4875.00	V	56.38	50.97	0.24	56.62	51.21	74.00	54.00	-2.79	AVG
7316.67	V	50.73	---	2.95	53.67	---	74.00	54.00	-0.33	Peak
N/A										
2676.67	H	56.78	49.70	-2.16	54.62	47.54	74.00	54.00	-6.46	AVG
3250.00	H	53.07	---	-0.85	52.23	---	74.00	54.00	-1.77	Peak
4875.00	H	51.08	---	0.24	51.32	---	74.00	54.00	-2.68	Peak
7316.67	H	46.49	---	2.95	49.44	---	74.00	54.00	-4.56	Peak
N/A										

Remark:

1. Measuring frequencies from 1 GHz to the 10th harmonic of highest fundamental frequency.
2. Radiated emissions measured in frequency above 1000MHz were made with an instrument using peak/average detector mode.
3. Average test would be performed if the peak result were greater than the average limit or as required by the applicant.
4. Data of measurement within this frequency range shown " --- " in the table above means the reading of emissions are attenuated more than 20dB below the permissible limits or the field strength is too small to be measured.
5. Measurements above show only up to 6 maximum emissions noted, or would be lesser, with " N/A " remark, if no specific emissions from the EUT are recorded (ie: margin > 20dB from the applicable limit) and considered that's already beyond the background noise floor.
6. Margin (dB) = Remark result (dBuV/m) – Average limit (dBuV/m).



Operation Mode: IEEE 802.11b / TX / CH High

Test Date: July 29, 2008

Temperature: 25°C

Tested by: Jerry Lin

Humidity: 50 % RH

Polarity: Ver. / Hor.

Frequency (MHz)	Ant.Pol. (H/V)	Reading (Peak) (dBuV)	Reading (Average) (dBuV)	Correction Factor (dB/m)	Result (Peak) (dBuV/m)	Result (Average) (dBuV/m)	Limit (Peak) (dBuV/m)	Limit (Average) (dBuV/m)	Margin (dB)	Remark
1660.00	V	56.85	---	-7.02	49.83	---	74.00	54.00	-4.17	Peak
2696.67	V	58.61	53.15	-2.11	56.50	51.04	74.00	54.00	-2.96	AVG
3283.33	V	50.34	---	-0.78	49.56	---	74.00	54.00	-4.44	Peak
4925.00	V	53.66	---	0.13	53.79	---	74.00	54.00	-0.21	Peak
7391.67	V	45.99	---	2.93	48.92	---	74.00	54.00	-5.08	Peak
N/A										
3283.33	H	53.41	---	-0.78	52.62	---	74.00	54.00	-1.38	Peak
4925.00	H	49.33	---	0.13	49.45	---	74.00	54.00	-4.55	Peak
7383.33	H	46.41	---	2.93	49.34	---	74.00	54.00	-4.66	Peak
N/A										Peak

Remark:

1. Measuring frequencies from 1 GHz to the 10th harmonic of highest fundamental frequency.
2. Radiated emissions measured in frequency above 1000MHz were made with an instrument using peak/average detector mode.
3. Average test would be performed if the peak result were greater than the average limit or as required by the applicant.
4. Data of measurement within this frequency range shown " --- " in the table above means the reading of emissions are attenuated more than 20dB below the permissible limits or the field strength is too small to be measured.
5. Measurements above show only up to 6 maximum emissions noted, or would be lesser, with " N/A " remark, if no specific emissions from the EUT are recorded (ie: margin>20dB from the applicable limit) and considered that's already beyond the background noise floor.
6. Margin (dB) = Remark result (dBuV/m) – Average limit (dBuV/m).

**Operation Mode:** IEEE 802.11g / TX / CH Low**Test Date:** July 29, 2008**Temperature:** 25°C**Tested by:** Jerry Lin**Humidity:** 50 % RH**Polarity:** Ver. / Hor.

Frequency (MHz)	Ant.Pol. (H/V)	Reading (Peak) (dBuV)	Reading (Average) (dBuV)	Correction Factor (dB/m)	Result (Peak) (dBuV/m)	Result (Average) (dBuV/m)	Limit (Peak) (dBuV/m)	Limit (Average) (dBuV/m)	Margin (dB)	Remark
2656.67	V	61.64	53.25	-2.22	59.42	51.03	74.00	54.00	-2.97	AVG
3216.67	V	48.63	---	-0.91	47.72	---	74.00	54.00	-6.28	Peak
4825.00	V	47.26	---	0.35	47.61	---	74.00	54.00	-6.39	Peak
7241.67	V	46.30	---	2.96	49.27	---	74.00	54.00	-4.73	Peak
N/A										
2653.33	H	56.27	54.21	-2.23	54.04	51.98	74.00	54.00	-2.02	AVG
3216.67	H	51.53	---	-0.91	50.62	---	74.00	54.00	-3.38	Peak
4825.00	H	47.82	---	0.35	48.17	---	74.00	54.00	-5.83	Peak
6125.00	H	46.49	---	1.31	47.81	---	74.00	54.00	-6.19	Peak
N/A										

Remark:

1. Measuring frequencies from 1 GHz to the 10th harmonic of highest fundamental frequency.
2. Radiated emissions measured in frequency above 1000MHz were made with an instrument using peak/average detector mode.
3. Average test would be performed if the peak result were greater than the average limit or as required by the applicant.
4. Data of measurement within this frequency range shown " --- " in the table above means the reading of emissions are attenuated more than 20dB below the permissible limits or the field strength is too small to be measured.
5. Measurements above show only up to 6 maximum emissions noted, or would be lesser, with " N/A " remark, if no specific emissions from the EUT are recorded (ie: margin > 20dB from the applicable limit) and considered that's already beyond the background noise floor.
6. Margin (dB) = Remark result (dBuV/m) – Average limit (dBuV/m).



Operation Mode: IEEE 802.11g / TX / CH Mid

Test Date: July 29, 2008

Temperature: 25°C

Tested by: Jerry Lin

Humidity: 50 % RH

Polarity: Ver. / Hor.

Frequency (MHz)	Ant.Pol. (H/V)	Reading (Peak) (dBuV)	Reading (Average) (dBuV)	Correction Factor (dB/m)	Result (Peak) (dBuV/m)	Result (Average) (dBuV/m)	Limit (Peak) (dBuV/m)	Limit (Average) (dBuV/m)	Margin (dB)	Remark
2680.00	V	63.53	54.08	-2.15	61.38	51.93	74.00	54.00	-2.07	AVG
3250.00	V	50.08	---	-0.85	49.24	---	74.00	54.00	-4.76	Peak
4875.00	V	46.22	---	0.24	46.46	---	74.00	54.00	-7.54	Peak
7308.33	V	47.31	---	2.95	50.26	---	74.00	54.00	-3.74	Peak
N/A										
2673.33	H	56.09	---	-2.17	53.91	---	74.00	54.00	-0.09	Peak
3250.00	H	52.17	---	-0.85	51.33	---	74.00	54.00	-2.67	Peak
4875.00	H	45.80	---	0.24	46.04	---	74.00	54.00	-7.96	Peak
7316.67	H	45.71	---	2.95	48.65	---	74.00	54.00	-5.35	Peak
N/A										

Remark:

1. Measuring frequencies from 1 GHz to the 10th harmonic of highest fundamental frequency.
2. Radiated emissions measured in frequency above 1000MHz were made with an instrument using peak/average detector mode.
3. Average test would be performed if the peak result were greater than the average limit or as required by the applicant.
4. Data of measurement within this frequency range shown " --- " in the table above means the reading of emissions are attenuated more than 20dB below the permissible limits or the field strength is too small to be measured.
5. Measurements above show only up to 6 maximum emissions noted, or would be lesser, with " N/A " remark, if no specific emissions from the EUT are recorded (ie: margin>20dB from the applicable limit) and considered that's already beyond the background noise floor.
6. Margin (dB) = Remark result (dBuV/m) – Average limit (dBuV/m).

**Operation Mode:** IEEE 802.11g / TX / CH High**Test Date:** July 29, 2008**Temperature:** 25°C**Tested by:** Jerry Lin**Humidity:** 50 % RH**Polarity:** Ver. / Hor.

Frequency (MHz)	Ant.Pol. (H/V)	Reading (Peak) (dBuV)	Reading (Average) (dBuV)	Correction Factor (dB/m)	Result (Peak) (dBuV/m)	Result (Average) (dBuV/m)	Limit (Peak) (dBuV/m)	Limit (Average) (dBuV/m)	Margin (dB)	Remark
2700.00	V	62.61	54.11	-2.10	60.50	52.01	74.00	54.00	-1.99	AVG
3283.33	V	49.56	---	-0.78	48.77	---	74.00	54.00	-5.23	Peak
4925.00	V	48.70	---	0.13	48.83	---	74.00	54.00	-5.17	Peak
7391.67	V	50.62	---	2.93	53.55	---	74.00	54.00	-0.45	Peak
N/A										
3283.33	H	53.57	---	-0.78	52.79	---	74.00	54.00	-1.21	Peak
4925.00	H	53.61	---	0.13	53.74	---	74.00	54.00	-0.26	Peak
7391.67	H	47.62	---	2.93	50.55	---	74.00	54.00	-3.45	Peak
N/A										

Remark:

1. Measuring frequencies from 1 GHz to the 10th harmonic of highest fundamental frequency.
2. Radiated emissions measured in frequency above 1000MHz were made with an instrument using peak/average detector mode.
3. Average test would be performed if the peak result were greater than the average limit or as required by the applicant.
4. Data of measurement within this frequency range shown " --- " in the table above means the reading of emissions are attenuated more than 20dB below the permissible limits or the field strength is too small to be measured.
5. Measurements above show only up to 6 maximum emissions noted, or would be lesser, with " N/A " remark, if no specific emissions from the EUT are recorded (ie: margin>20dB from the applicable limit) and considered that's already beyond the background noise floor.
6. Margin (dB) = Remark result (dBuV/m) – Average limit (dBuV/m).



7.7 POWERLINE CONDUCTED EMISSIONS

LIMIT

According to §15.207(a), except as shown in paragraphs (b) and (c) of this section, for an intentional radiator that is designed to be connected to the public utility (AC) power line, the radio frequency voltage that is conducted back onto the AC power line on any frequency or frequencies within the band 150 kHz to 30 MHz shall not exceed the limits in the following table, as measured using a 50 μ H/50 ohms line impedance stabilization network (LISN). Compliance with the provisions of this paragraph shall be based on the measurement of the radio frequency voltage between each power line and ground at the power terminal. The lower limit applies at the boundary between the frequency ranges.

Frequency Range (MHz)	Limits (dB μ V)	
	Quasi-peak	Average
0.15 to 0.50	66 to 56*	56 to 46*
0.50 to 5	56	46
5 to 30	60	50

Test Configuration

See test photographs attached in Appendix II for the actual connections between EUT and support equipment.

TEST PROCEDURE

1. The EUT was placed on a table, which is 0.8m above ground plane.
2. Maximum procedure was performed on the six highest emissions to ensure EUT compliance.
3. Repeat above procedures until all frequency measured were complete.



TEST RESULTS

The initial step in collecting conducted data is a spectrum analyzer peak scan of the measurement range. Significant peaks are then marked as shown on the following data page, and these signals are then quasi-peaked.

Test Data

Operation Mode: Normal Link **Test Date:** July 29, 2008
Temperature: 22°C **Tested by:** Chihkai Chung
Humidity: 54% RH

Frequency (MHz)	QP Reading (dBuV)	AV Reading (dBuV)	Corr. factor (dB)	QP Result (dBuV)	AV Result (dBuV)	QP Limit (dBuV)	AV Limit (dBuV)	QP Margin (dB)	AV Margin (dB)	Note
0.1500	26.80	17.50	0.20	27.00	17.70	66.00	56.00	-39.00	-38.30	L1
0.6600	30.07	19.57	0.03	30.10	19.60	56.00	46.00	-25.90	-26.40	L1
0.9900	32.77	20.27	0.03	32.80	20.30	56.00	46.00	-23.20	-25.70	L1
4.0150	32.34	22.44	0.16	32.50	22.60	56.00	46.00	-23.50	-23.40	L1
6.5950	35.96	25.26	0.34	36.30	25.60	60.00	50.00	-23.70	-24.40	L1
10.1400	31.33	21.03	0.57	31.90	21.60	60.00	50.00	-28.10	-28.40	L1
0.1850	31.34	17.24	0.16	31.50	17.40	64.26	54.26	-32.76	-36.86	L2
0.3200	40.00	28.10	0.10	40.10	28.20	59.71	49.71	-19.61	-21.51	L2
0.6350	31.27	18.47	0.03	31.30	18.50	56.00	46.00	-24.70	-27.50	L2
1.4400	28.57	17.47	0.03	28.60	17.50	56.00	46.00	-27.40	-28.50	L2
4.6450	33.38	22.68	0.22	33.60	22.90	56.00	46.00	-22.40	-23.10	L2
12.9350	33.68	22.18	0.62	34.30	22.80	60.00	50.00	-25.70	-27.20	L2

Remark:

1. Measuring frequencies from 0.15 MHz to 30MHz.
2. The emissions measured in frequency range from 0.15 MHz to 30MHz were made with an instrument using Quasi-peak detector and average detector.
3. The IF bandwidth of SPA between 0.15MHz to 30MHz was 10kHz; the IF bandwidth of Test Receiver between 0.15MHz to 30MHz was 9kHz;
4. L1 = Line One (Live Line) / L2 = Line Two (Neutral Line)



Test Plots

Conducted emissions (Line 1)

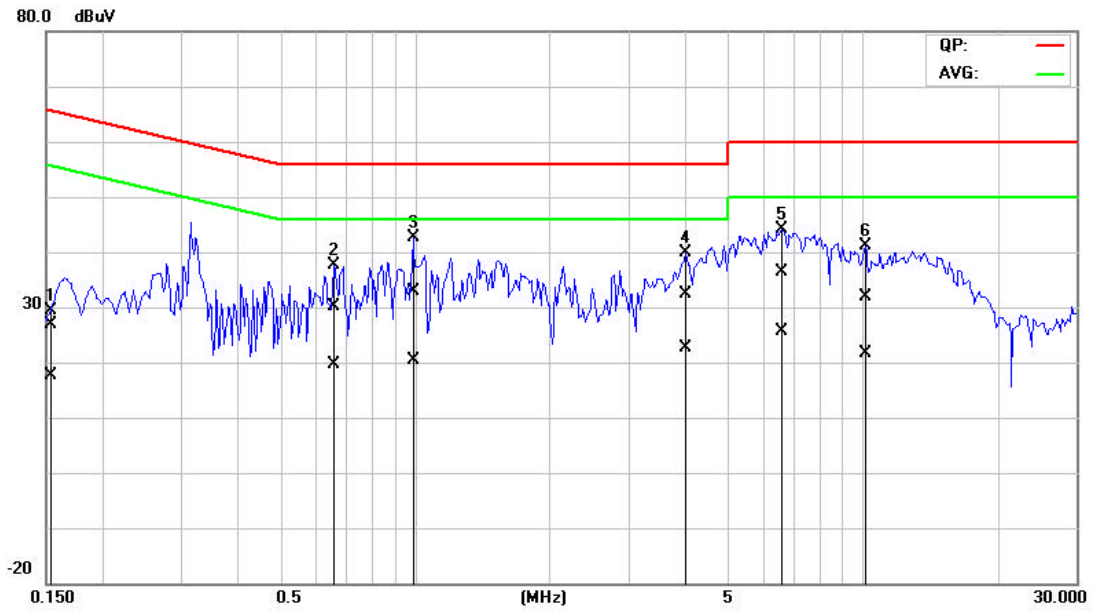

Conducted emissions (Line 2)

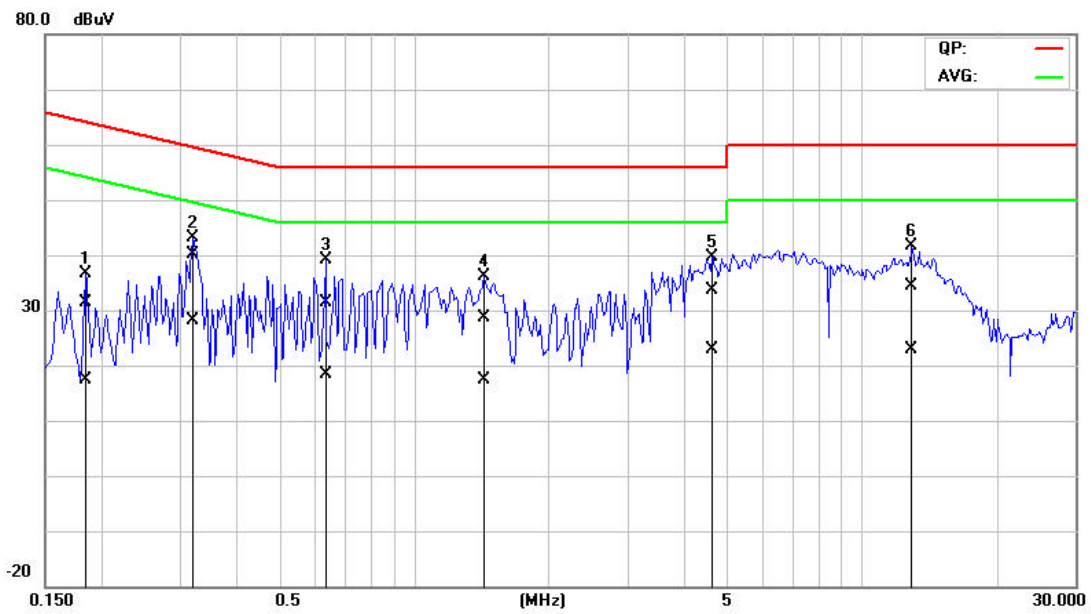



APPENDIX I RADIO FREQUENCY EXPOSURE

LIMIT

Systems operating under the provisions of this section shall be operated in a manner that ensures that the public is not exposed to radio frequency energy levels in excess of the Commission's guidelines. See §15.247(i) and §1.1307(b)(1) of this chapter.

EUT Specification

EUT	Wireless Compact Router
Frequency band (Operating)	<input checked="" type="checkbox"/> WLAN: 2.412GHz ~ 2.462GHz <input type="checkbox"/> WLAN: 5.18GHz ~ 5.32GHz / 5.50GHz ~ 5.70GHz <input type="checkbox"/> WLAN: 5.745GHz ~ 5.825GHz <input type="checkbox"/> Bluetooth: <u>2.402GHz ~ 2.480 GHz</u>
Device category	<input type="checkbox"/> Portable (<20cm separation) <input checked="" type="checkbox"/> Mobile (>20cm separation)
Exposure classification	<input type="checkbox"/> Occupational/Controlled exposure (S = 5mW/cm2) <input checked="" type="checkbox"/> General Population/Uncontrolled exposure (S=1mW/cm2)
Antenna diversity	<input checked="" type="checkbox"/> Single antenna <input type="checkbox"/> Multiple antennas <input type="checkbox"/> Tx diversity <input type="checkbox"/> Rx diversity <input type="checkbox"/> Tx/Rx diversity
Max. output power	IEEE 802.11b: 16.56 dBm(45.29mW) IEEE 802.11g: 17.44 dBm(55.46mW)
Antenna gain (Max)	1.8 dBi (Numeric gain: 1.51)
Evaluation applied	<input checked="" type="checkbox"/> MPE Evaluation* <input type="checkbox"/> SAR Evaluation <input type="checkbox"/> N/A

Remark:

- The maximum output power is 17.44dBm (55.46mW) at 2462MHz (with 1.51 numeric antenna gain.)*
- DTS device is not subject to routine RF evaluation; MPE estimate is used to justify the compliance.*
- For mobile or fixed location transmitters, no SAR consideration applied. The maximum power density is 1.0 mW/cm^2 even if the calculation indicates that the power density would be larger.*

TEST RESULTS

No non-compliance noted.



Calculation

Given $E = \frac{\sqrt{30 \times P \times G}}{d}$ & $S = \frac{E^2}{3770}$

Where $E =$ Field strength in Volts / meter

$P =$ Power in Watts

$G =$ Numeric antenna gain

$d =$ Distance in meters

$S =$ Power density in milliwatts / square centimeter

Combining equations and re-arranging the terms to express the distance as a function of the remaining variables yields:

$$S = \frac{30 \times P \times G}{3770 d^2}$$

Changing to units of mW and cm, using:

$$P (mW) = P (W) / 1000 \text{ and}$$

$$d (cm) = d(m) / 100$$

Yields

$$S = \frac{30 \times (P / 1000) \times G}{3770 \times (d / 100)^2} = 0.0796 \times \frac{P \times G}{d^2} \quad \text{Equation 1}$$

Where $d =$ Distance in cm

$P =$ Power in mW

$G =$ Numeric antenna gain

$S =$ Power density in mW / cm²

Maximum Permissible Exposure

EUT output power = 55.46mW

Numeric Antenna gain = 1.51

Substituting the MPE safe distance using d = 20 cm into Equation 1:

Yields

$$S = 0.000199 \times P \times G$$

Where $P =$ Power in mW

$G =$ Numeric antenna gain

$S =$ Power density in mW / cm²

→ Power density = 0.0167 mW / cm²

(For mobile or fixed location transmitters, the maximum power density is 1.0 mW/cm² even if the calculation indicates that the power density would be larger.)