



FCC TEST REPORT

REPORT NO.: RF960903H01-1

MODEL NO.: WRT54G3G V2-XX

RECEIVED: Sep. 03, 2007

TESTED: Sep. 09 to 11, 2007

ISSUED: Sep. 26, 2007

APPLICANT: Cisco-Linksys LLC

ADDRESS: 121 Theory Drive Irvine, CA 92617(USA)

ISSUED BY: Advance Data Technology Corporation

LAB LOCATION: No. 81-1, Lu Liao Keng, 9 Ling, Wu Lung Tsuen,
Chiung Lin Hsiang, Hsin Chu Hsien,
Taiwan, R.O.C.

This test report consists of 45 pages in total. It may be duplicated completely for legal use with the approval of the applicant. It should not be reproduced except in full, without the written approval of our laboratory. The client should not use it to claim product endorsement by TAF, A2LA or any government agencies. The test results in the report only apply to the tested sample. The test results in this report are traceable to the national or international standards.





Table of Contents

1	CERTIFICATION	3
2	SUMMARY OF TEST RESULTS	4
2.1	MEASUREMENT UNCERTAINTY	4
3	GENERAL INFORMATION.....	5
3.1	GENERAL DESCRIPTION OF EUT	5
3.2	DESCRIPTION OF TEST MODES	7
3.3	TEST MODE APPLICABILITY AND TESTED CHANNEL DETAIL:	8
3.4	GENERAL DESCRIPTION OF APPLIED STANDARDS	9
3.5	DESCRIPTION OF SUPPORT UNITS.....	10
3.6	CONFIGURATION OF SYSTEM UNDER TEST	11
4	TEST TYPES AND RESULTS	13
4.1	CONDUCTED EMISSION MEASUREMENT	13
4.1.1	LIMITS OF CONDUCTED EMISSION MEASUREMENT	13
4.1.2	TEST INSTRUMENTS.....	13
4.1.3	TEST PROCEDURES	14
4.1.4	TEST SETUP	14
4.1.5	EUT OPERATING CONDITIONS	15
4.1.6	TEST RESULTS	16
4.1.7	TEST RESULTS	18
4.2	RADIATED EMISSION MEASUREMENT	20
4.2.1	LIMITS OF RADIATED EMISSION MEASUREMENT	20
4.2.2	TEST INSTRUMENTS.....	21
4.2.3	TEST PROCEDURES	22
4.2.4	TEST SETUP	23
4.2.5	EUT OPERATING CONDITIONS	23
4.2.6	TEST RESULTS	24
4.2.7	TEST RESULTS - DSSS	30
5	PHOTOGRAPHS OF THE TEST CONFIGURATION	36
6	INFORMATION ON THE TESTING LABORATORIES	44
7	APPENDIX A - MODIFICATIONS RECORDERS FOR ENGINEERING CHANGES TO THE EUT BY THE LAB	45



1 CERTIFICATION

PRODUCT : Wireless-G Router for Mobile Broadband
BRAND NAME : Linksys
MODEL NO. : WRT54G3G V2-XX
TESTED : Sep. 09 to 11, 2007
APPLICANT : Cisco-Linksys LLC
TEST SAMPLE : ENGINEERING SAMPLE
STANDARDS : 47 CFR Part 15, Subpart C (Section 15.247)
ANSI C63.4-2003

The above equipment (Model: WRT54G3G V2-ST) has been tested by **Advance Data Technology Corporation**, and found compliance with the requirement of the above standards. The test record, data evaluation & Equipment Under Test (EUT) configurations represented herein are true and accurate accounts of the measurements of the sample's EMC characteristics under the conditions specified in this report.

PREPARED BY :  , **DATE:** Sep. 26, 2007
(Sunny Wen, Specialist)

TECHNICAL ACCEPTANCE :  , **DATE:** Sep. 26, 2007
Responsible for RF (Hank Chung, Deputy Manager)

APPROVED BY :  , **DATE:** Sep. 26, 2007
(May Chen, Deputy Manager)

2 SUMMARY OF TEST RESULTS

The EUT has been tested according to the following specifications:

APPLIED STANDARD: 47 CFR Part 15, Subpart C			
Standard Section	Test Type and Limit	Result	REMARK
15.207	AC Power Conducted Emission	PASS	Meet the requirement of limit Minimum passing margin is -16.40 dB at 13.770 MHz
15.247(c)	Transmitter Radiated Emissions Limit: Table 15.209	PASS	Meet the requirement of limit Minimum passing margin is -0.50 dB at 4924.00 MHz

2.1 MEASUREMENT UNCERTAINTY

Where relevant, the following measurement uncertainty levels have been estimated for tests performed on the EUT as specified in CISPR 16-4:

This uncertainty represents an expanded uncertainty expressed at approximately the 95% confidence level using a coverage factor of k=2.

Measurement	Value
Conducted emissions	2.41 dB
Radiated emissions (30MHz-1GHz)	3.89 dB
Radiated emissions (1GHz -18GHz)	2.21 dB
Radiated emissions (18GHz -40GHz)	1.88 dB

3 GENERAL INFORMATION

3.1 GENERAL DESCRIPTION OF EUT

PRODUCT	Wireless-G Router for Mobile Broadband
MODEL NO.	WRT54G3G V2-XX
FCC ID	Q87-WRT54G3GV2
POWER SUPPLY	DC 12V from power adapter
MODULATION TYPE	CCK, DQPSK, DBPSK for DSSS 64QAM, 16QAM, QPSK, BPSK for OFDM
RADIO TECHNOLOGY	DSSS, OFDM
TRANSFER RATE	802.11b: 11/5.5/2/1Mbps 802.11g: 54/48/36/24/18/12/9/6Mbps
FREQUENCY RANGE	2412MHz ~ 2462MHz
NUMBER OF CHANNEL	11
CHANNEL SPACING	5MHz
OUTPUT POWER	802.11b: 70.795mW 802.11g: 102.329mW
ANTENNA TYPE	External Fixed Dipole antenna (Antenna gain : 3.3dBi)
DATA CABLE	NA
I/O PORT	Ethernet port x 4, Modem port x 1, Data Card Slot port x 1, USB port x 3

NOTE:

- The EUT has different models names, which are identical to each other in all aspects except for the followings :

Brand	Model No.
Linksys	WRT54G3G V2-XX (1st X : 0-9 & A-Z, 2st X : 0-9 & A-Z)

From the above models, model: **WRT54G3G V2-ST** was selected as representative model for the test and its data was recorded in this report.

2. The EUT was tested with following six GSM Cards individually; therefore emission tests are added for simultaneously transmit between wireless LAN and GSM function. The emission tests have been performed at the worst channel of both WLAN and GSM, and recorded in the report.

Item	Brand name	Model name	FCC ID
1	SIERRA WIRELESS	AC595	N7NAC595
2	Sprint	S620	PKRNVWV620
3	Sprint	Merlin S720	PKRNVWV720
4	Sprint	U720	PKRNVWMCD3000
5	HUAWEI	E220	QISE220
6	Sprint	595U	N7N-MC5725U

For conducted emission, the worse case was found in No. 1 & 5. Its test data was recorded in this report individually.

3. The EUT was operated with the following power adapter :

BRAND:	LINKSYS
MODEL:	PSA18R-120P(CA)-R
INPUT:	AC 100~240V, 0.5A, 50~60Hz
OUTPUT:	DC 12V, 1.5A, 1.8m / nonshield with one core

4. The EUT operates in the 2.4GHz frequency spectrum with throughput of up to 54Mbps.
5. The EUT complies with IEEE 802.11g standards, and backwards compatible with IEEE 802.11b products.
6. The above EUT information was declared by the manufacturer and for more detailed features description, please refer to the manufacturer's specifications or User's Manual.

3.2 DESCRIPTION OF TEST MODES

Operated in 2400 ~ 2483.5MHz band:

For 802.11b/g normal mode: Eleven channels are provided to this EUT.

Channel	Frequency	Channel	Frequency
1	2412 MHz	7	2442 MHz
2	2417 MHz	8	2447 MHz
3	2422 MHz	9	2452 MHz
4	2427 MHz	10	2457 MHz
5	2432 MHz	11	2462 MHz
6	2437 MHz		

3.3 TEST MODE APPLICABILITY AND TESTED CHANNEL DETAIL:

EUT configure mode	Applicable to			Description
	PLC	RE<1G	RE≥1G	
A	√	√	√	Co-located with card 1
B		√	√	Co-located with card 2
C		√	√	Co-located with card 3
D		√	√	Co-located with card 4
E	√	√	√	Co-located with card 5
F		√	√	Co-located with card 6

Where PLC: Power Line Conducted Emission RE<1G RE: Radiated Emission below 1GHz
RE≥1G: Radiated Emission above 1GHz

Power Line Conducted Emission Test:

- Pre-Scan has been conducted to determine the worst-case mode from all possible combinations between available modulations, data rates and antenna ports (if EUT with antenna diversity architecture).
- Following channel(s) was (were) selected for the final test as listed below.

Mode	Available Channel	Tested Channel	Modulation Technology	Modulation Type	Data Rate (Mbps)
802.11b	1 to 11	11	DSSS	CCK	11

Radiated Emission Test (Below 1 GHz):

- Pre-Scan has been conducted to determine the worst-case mode from all possible combinations between available modulations, data rates and antenna ports (if EUT with antenna diversity architecture).
- Following channel(s) was (were) selected for the final test as listed below.

Mode	Available Channel	Tested Channel	Modulation Technology	Modulation Type	Data Rate (Mbps)
802.11b	1 to 11	11	DSSS	CCK	1

Radiated Emission Test (Above 1 GHz):

- Pre-Scan has been conducted to determine the worst-case mode from all possible combinations between available modulations, data rates and antenna ports (if EUT with antenna diversity architecture).
- Following channel(s) was (were) selected for the final test as listed below.

Mode	Available Channel	Tested Channel	Modulation Technology	Modulation Type	Data Rate (Mbps)
802.11b	1 to 11	11	DSSS	CCK	1



3.4 GENERAL DESCRIPTION OF APPLIED STANDARDS

The EUT is a Wireless-G Router for Mobile Broadband. According to the specifications of the manufacturer, it must comply with the requirements of the following standards:

47 CFR Part 15, Subpart C. (15.247)
ANSI C63.4 : 2003

All tests have been performed and recorded as per the above standards.



3.5 DESCRIPTION OF SUPPORT UNITS

The EUT has been tested as an independent unit together with other necessary accessories or support units. The following support units or accessories were used to form a representative test configuration during the tests.

No.	Product	Brand	Model No.	Serial No.	FCC ID
1	NOTEBOOK COMPUTER	DELL	PP19L	CN-OHC416-70166-5CA-0448	PIW632500516610
2	NOTEBOOK COMPUTER	DELL	PP21L	CN-0GD366-70166-5B3-09ZX	QDS-BRCM1016
3	HUB	AVSYS	110H8	01-20E-000002	DoC
4	iPod	Apple	A1137	5K7170JBUPR	DoC

No.	Signal cable description
1	NA
2	NA
3	NA
4	NA

NOTE: All power cords of the above support units are non-shielded (1.8m).

3.6 CONFIGURATION OF SYSTEM UNDER TEST

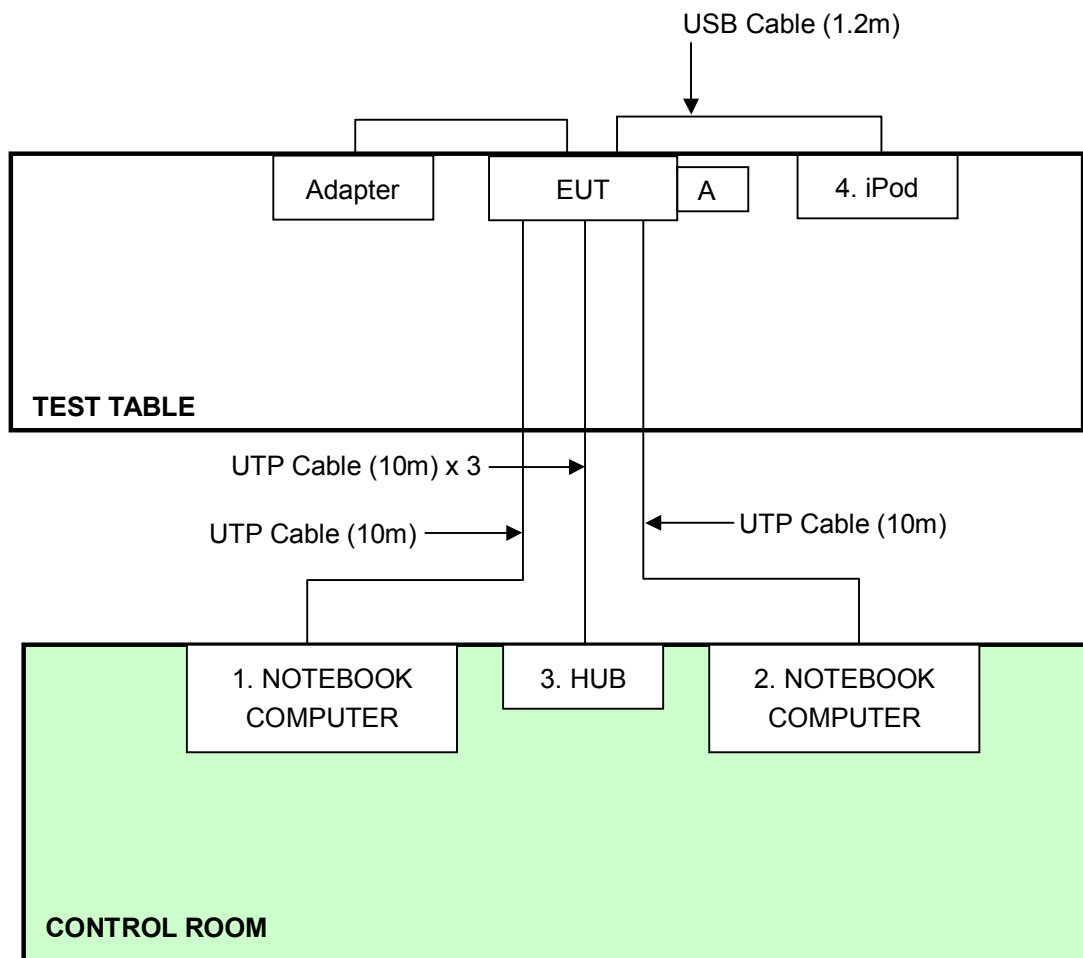

NOTE:

1. Item A is GSM Card (3G card, USB 3G Card).

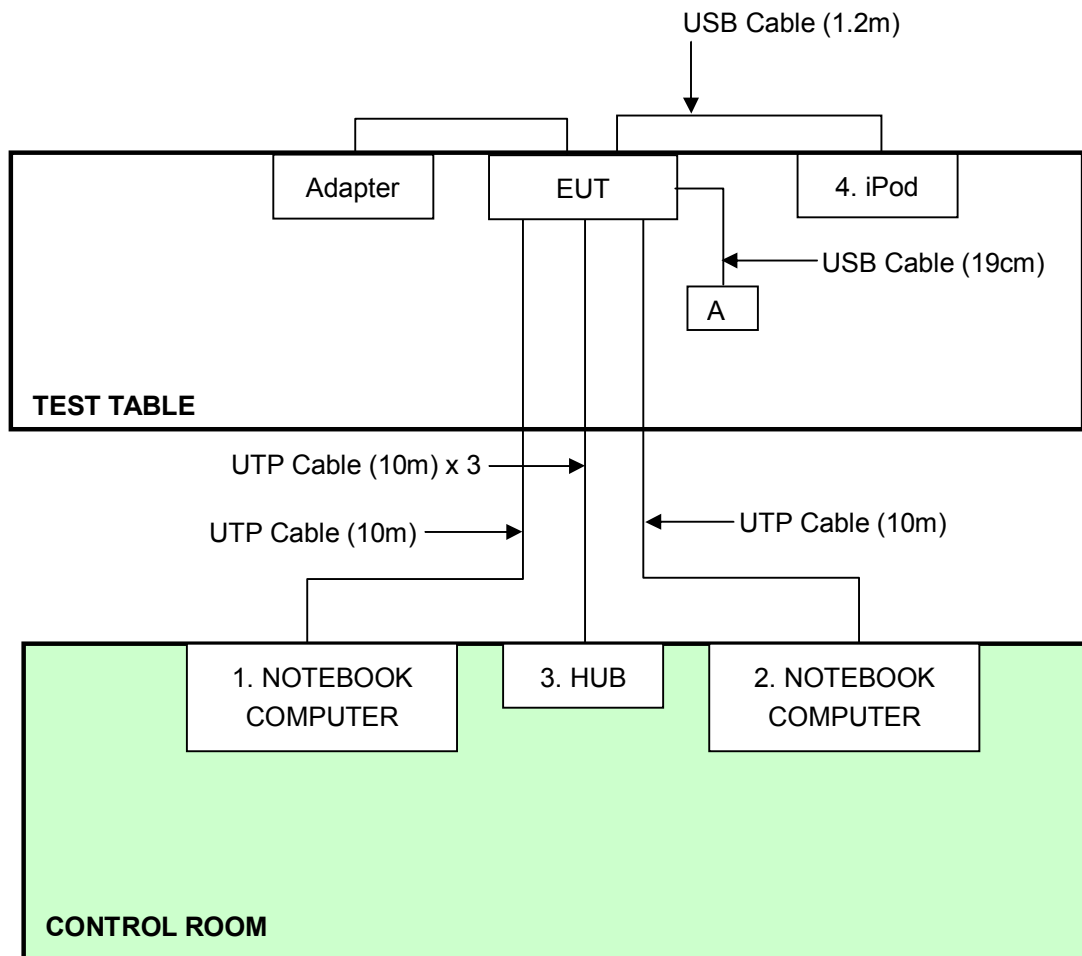

NOTE:

1. Item A is GSM Card (USB 3G Card).



4 TEST TYPES AND RESULTS

4.1 CONDUCTED EMISSION MEASUREMENT

4.1.1 LIMITS OF CONDUCTED EMISSION MEASUREMENT

FREQUENCY OF EMISSION (MHz)	CONDUCTED LIMIT (dB μ V)	
	Quasi-peak	Average
0.15-0.5	66 to 56	56 to 46
0.5-5	56	46
5-30	60	50

NOTE:

1. The lower limit shall apply at the transition frequencies.
2. All emanations from a class B digital device or system, including any network of conductors and apparatus connected thereto, shall not exceed the level of field strengths specified above.

4.1.2 TEST INSTRUMENTS

DESCRIPTION & MANUFACTURER	MODEL NO.	SERIAL NO.	CALIBRATED UNTIL
Test Receiver	ESCS 30	847124/029	Mar. 28, 2008
Line-Impedance Stabilization Network(for EUT)	ENV-216	100071	Nov. 26, 2007
Line-Impedance Stabilization Network(for Peripheral)	ESH3-Z5	848773/004	Oct. 26, 2007
RF Cable (JETBAO)	RG233/U	Cable_CB_01	Dec. 09, 2007
Terminator	50	2	Oct. 30, 2007
Software	ADT_Cond_V7.3.2	NA	NA

- NOTE: 1. The calibration interval of the above test instruments is 12 months and the calibrations are traceable to NML/ROC and NIST/USA.
 2. The test was performed in ADT Shielded Room No. B.
 3. The VCCI Con B Registration No. is C-2193.

4.1.3 TEST PROCEDURES

- a. The EUT/HOST was placed 0.4 meters from the conducting wall of the shielded room with EUT/HOST being connected to the power mains through a line impedance stabilization network (LISN). Other support units were connected to the power mains through another LISN. The two LISNs provide 50 ohm/ 50uH of coupling impedance for the measuring instrument.
- b. Both lines of the power mains connected to the EUT/HOST were checked for maximum conducted interference.
- c. The frequency range from 150 kHz to 30 MHz was searched. Emission levels over 10dB under the prescribed limits could not be reported

4.1.4 TEST SETUP

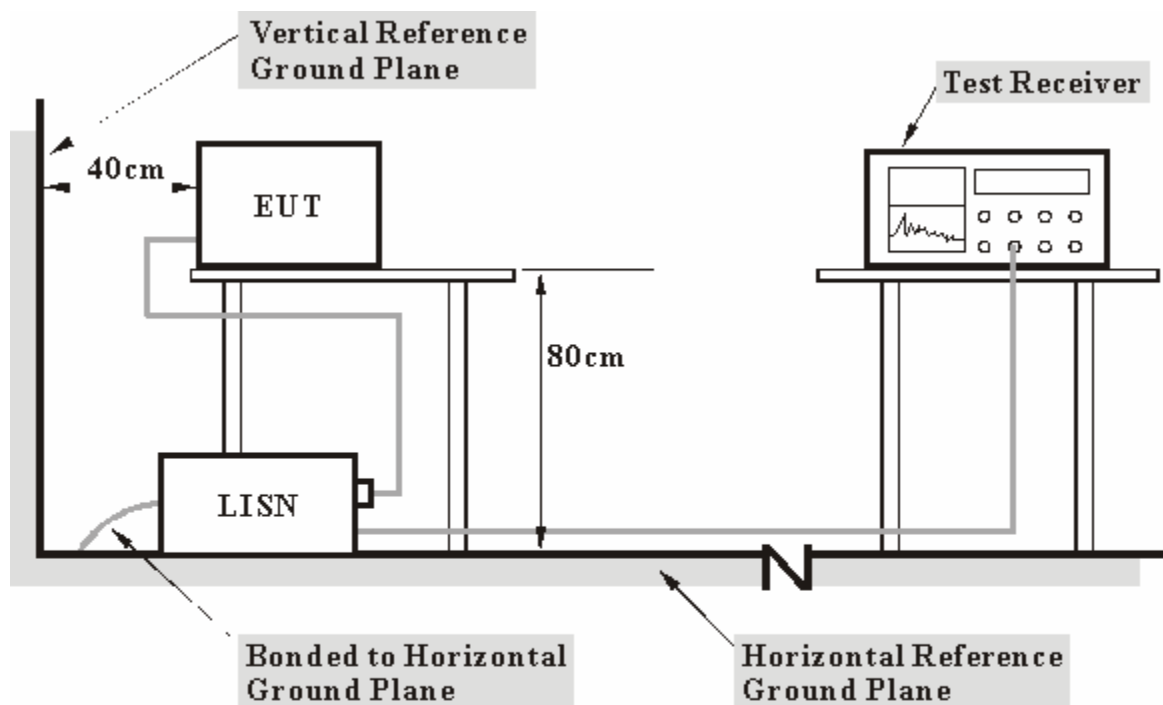

- Note:**
1. Support units were connected to second LISN.
 2. Both of LISNs (AMIN) 80 cm from EUT and at the least 80 cm from other units and other metal planes support units.

For the actual test configuration, please refer to the related item – Photographs of the Test Configuration.

4.1.5 EUT OPERATING CONDITIONS

- A. Placed the EUT on the testing table.
- B. Prepared the computer system (support unit 1, 2) to act as communication partner and placed them outside of testing area.
- C. The communication partner runs test program " MFGTEST " to enable EUT under transmission/receiving condition continuously at specific channel frequency via UTP cables and wireless.

4.1.6 TEST RESULTS

MODULATION TYPE	CCK	CHANNEL	CH11
INPUT POWER (SYSTEM)	120Vac, 60 Hz	6dB BANDWIDTH	9 kHz
ENVIRONMENTAL CONDITIONS	27 deg. C, 59%RH, 962hPa	TRANSFER RATE	11Mbps
PHASE	Line (L)	TEST MODE	Mode A
TESTED BY	Tony Chen		

No	Freq. [MHz]	Corr. Factor (dB)	Reading Value		Emission Level		Limit		Margin	
			[dB (uV)]		[dB (uV)]		[dB (uV)]		(dB)	
			Q.P.	AV.	Q.P.	AV.	Q.P.	AV.	Q.P.	AV.
1	0.205	0.40	42.60	-	43.00	-	63.42	53.42	-20.42	-
2	0.275	0.40	38.70	-	39.10	-	60.97	50.97	-21.87	-
3	0.412	0.40	34.90	-	35.30	-	57.61	47.61	-22.31	-
4	1.306	0.43	31.25	-	31.68	-	56.00	46.00	-24.32	-
5	3.512	0.58	34.23	-	34.81	-	56.00	46.00	-21.19	-
6	13.793	1.03	38.73	-	39.76	-	60.00	50.00	-20.24	-
7	14.992	1.10	32.43	-	33.53	-	60.00	50.00	-26.47	-

- REMARKS:**
1. Q.P. and AV. are abbreviations of quasi-peak and average individually.
 2. "-": The Quasi-peak reading value also meets average limit and measurement with the average detector is unnecessary.
 3. The emission levels of other frequencies were very low against the limit.
 4. Margin value = Emission level - Limit value
 5. Correction factor = Insertion loss + Cable loss
 6. Emission Level = Correction Factor + Reading Value.

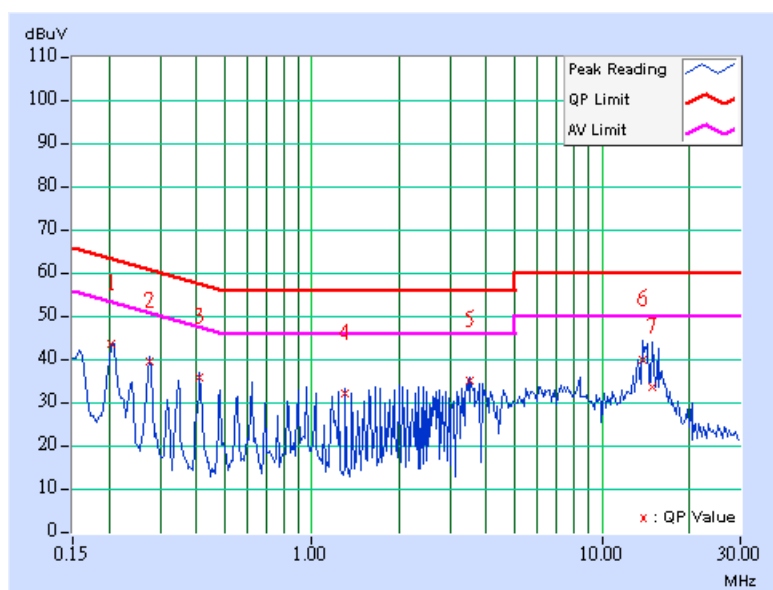

MODULATION TYPE	CCK	CHANNEL	CH11
INPUT POWER (SYSTEM)	120Vac, 60 Hz	6dB BANDWIDTH	9 kHz
ENVIRONMENTAL CONDITIONS	27 deg. C, 59%RH, 962hPa	TRANSFER RATE	11Mbps
PHASE	Neutral (N)	TEST MODE	Mode A
TESTED BY	Tony Chen		

No	Freq. [MHz]	Corr. Factor (dB)	Reading Value		Emission Level		Limit		Margin	
			[dB (uV)]		[dB (uV)]		[dB (uV)]		(dB)	
			Q.P.	AV.	Q.P.	AV.	Q.P.	AV.	Q.P.	AV.
1	0.158	0.20	40.81	-	41.01	-	65.58	55.58	-24.57	-
2	0.205	0.20	43.16	-	43.36	-	63.42	53.42	-20.06	-
3	0.345	0.20	36.58	-	36.78	-	59.07	49.07	-22.29	-
4	0.482	0.21	33.43	-	33.64	-	56.30	46.30	-22.66	-
5	2.822	0.44	30.75	-	31.19	-	56.00	46.00	-24.81	-
6	14.273	1.16	41.31	-	42.47	-	60.00	50.00	-17.53	-

- REMARKS:**
1. Q.P. and AV. are abbreviations of quasi-peak and average individually.
 2. "-": The Quasi-peak reading value also meets average limit and measurement with the average detector is unnecessary.
 3. The emission levels of other frequencies were very low against the limit.
 4. Margin value = Emission level - Limit value
 5. Correction factor = Insertion loss + Cable loss
 6. Emission Level = Correction Factor + Reading Value.

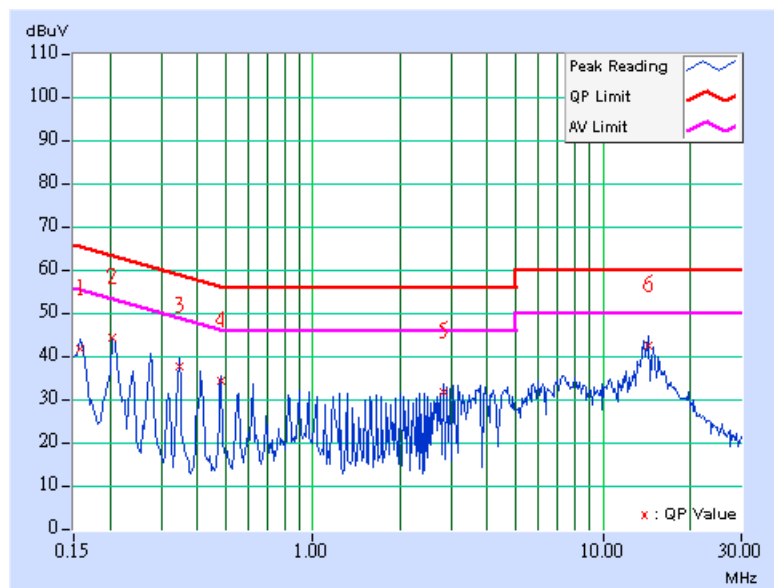

4.1.7 TEST RESULTS

MODULATION TYPE	CCK	CHANNEL	CH11
INPUT POWER (SYSTEM)	120Vac, 60 Hz	6dB BANDWIDTH	9 kHz
ENVIRONMENTAL CONDITIONS	27 deg. C, 59%RH, 962hPa	TRANSFER RATE	11Mbps
PHASE	Line (L)	TEST MODE	Mode E
TESTED BY	Tony Chen		

No	Freq. [MHz]	Corr. Factor (dB)	Reading Value		Emission Level		Limit		Margin	
			[dB (uV)]		[dB (uV)]		[dB (uV)]		(dB)	
			Q.P.	AV.	Q.P.	AV.	Q.P.	AV.	Q.P.	AV.
1	0.205	0.40	42.34	-	42.74	-	63.42	53.42	-20.68	-
2	0.275	0.40	39.06	-	39.46	-	60.97	50.97	-21.51	-
3	0.412	0.40	36.09	-	36.49	-	57.61	47.61	-21.12	-
4	0.482	0.40	33.97	-	34.37	-	56.30	46.30	-21.93	-
5	3.168	0.56	34.45	-	35.01	-	56.00	46.00	-20.99	-
6	13.770	1.03	42.47	-	43.50	-	60.00	50.00	-16.50	-

- REMARKS:**
1. Q.P. and AV. are abbreviations of quasi-peak and average individually.
 2. "-": The Quasi-peak reading value also meets average limit and measurement with the average detector is unnecessary.
 3. The emission levels of other frequencies were very low against the limit.
 4. Margin value = Emission level - Limit value
 5. Correction factor = Insertion loss + Cable loss
 6. Emission Level = Correction Factor + Reading Value.

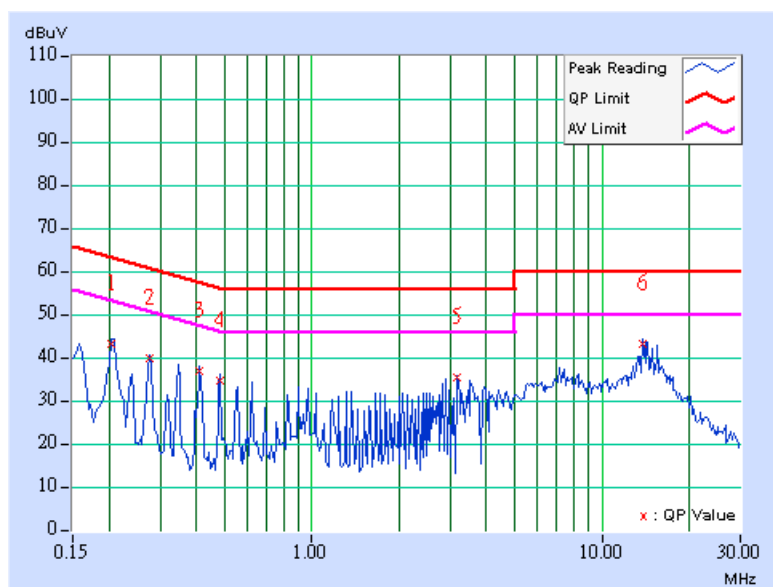

MODULATION TYPE	CCK	CHANNEL	CH11
INPUT POWER (SYSTEM)	120Vac, 60 Hz	6dB BANDWIDTH	9 kHz
ENVIRONMENTAL CONDITIONS	27 deg. C, 59%RH, 962hPa	TRANSFER RATE	11Mbps
PHASE	Neutral (N)	TEST MODE	Mode E
TESTED BY	Tony Chen		

No	Freq. [MHz]	Corr. Factor (dB)	Reading Value		Emission Level		Limit		Margin	
			[dB (uV)]		[dB (uV)]		[dB (uV)]		(dB)	
			Q.P.	AV.	Q.P.	AV.	Q.P.	AV.	Q.P.	AV.
1	0.158	0.20	38.21	-	38.41	-	65.58	55.58	-27.17	-
2	0.205	0.20	41.43	-	41.63	-	63.42	53.42	-21.79	-
3	0.275	0.20	38.58	-	38.78	-	60.97	50.97	-22.19	-
4	1.033	0.30	31.55	-	31.85	-	56.00	46.00	-24.15	-
5	3.652	0.48	32.89	-	33.37	-	56.00	46.00	-22.63	-
6	13.770	1.13	42.47	-	43.60	-	60.00	50.00	-16.40	-

- REMARKS:**
1. Q.P. and AV. are abbreviations of quasi-peak and average individually.
 2. "-": The Quasi-peak reading value also meets average limit and measurement with the average detector is unnecessary.
 3. The emission levels of other frequencies were very low against the limit.
 4. Margin value = Emission level - Limit value
 5. Correction factor = Insertion loss + Cable loss
 6. Emission Level = Correction Factor + Reading Value.

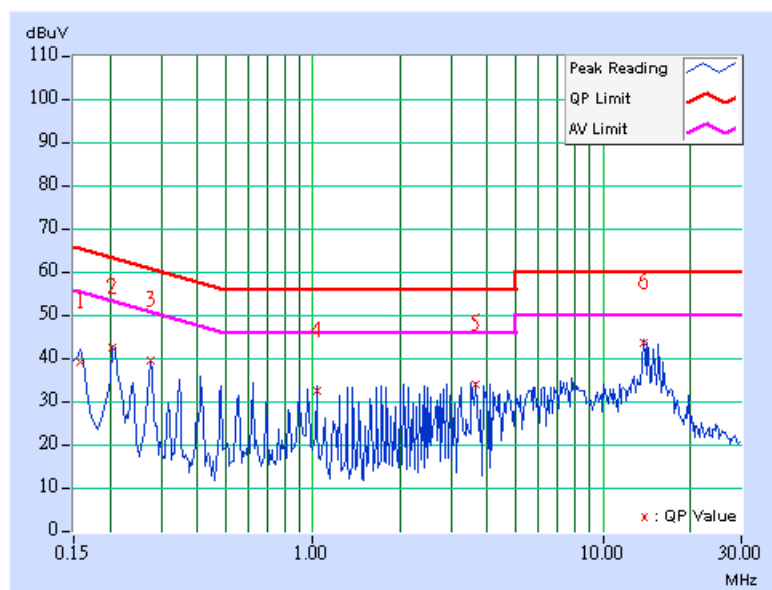

4.2 RADIATED EMISSION MEASUREMENT

4.2.1 LIMITS OF RADIATED EMISSION MEASUREMENT

Emissions radiated outside of the specified bands, shall be according to the general radiated limits in 15.209 as following:

Frequencies (MHz)	Field strength (microvolts/meter)	Measurement distance (meters)
0.009-0.490	2400/F(kHz)	300
0.490-1.705	24000/F(kHz)	30
1.705-30.0	30	30
30-88	100	3
88-216	150	3
216-960	200	3
Above 960	500	3

NOTE:

1. The lower limit shall apply at the transition frequencies.
2. Emission level (dBuV/m) = 20 log Emission level (uV/m).
3. As shown in 15.35(b), for frequencies above 1000MHz, the field strength limits are based on average detector, however, the peak field strength of any emission shall not exceed the maximum permitted average limits, specified above by more than 20dB under any condition of modulation.



4.2.2 TEST INSTRUMENTS

DESCRIPTION & MANUFACTURER	MODEL NO.	SERIAL NO.	CALIBRATED UNTIL
ADVANTEST Spectrum Analyzer	R3271A	85060311	July 03, 2008
HP Pre_Amplifier	8449B	3008A01922	Sep. 18, 2007
ROHDE & SCHWARZ Test Receiver	ESCS30	100375	Sep. 20, 2007
CHASE Broadband Antenna	VULB 9168	138	July 17, 2008
Schwarzbeck Horn_Antenna	BBHA9120	D124	Jan. 01, 2008
Schwarzbeck Horn_Antenna	BBHA 9170	BBHA9170153	Jan. 25, 2008
SCHWARZBECK Biconical Antenna	VHBA9123	459	Jun. 08, 2009
SCHWARZBECK Periodic Antenna	UPA6108	1148	Jun. 08, 2009
R&S Loop Antenna	HFH2-Z2	881058/15	Nov. 29, 2007
RF Switches (ARNITSU)	CS-201	1565157	NA
RF CABLE (Chaintek)	SF102	22054-2	Nov. 14. 2007
RF Cable(RICHTEC)	9913-30M N-N Cable	STCCAB-30M-1 GHz	Jul. 15, 2008
Software	ADT_Radiated_V 7.6.15.7	NA	NA
CHANCE MOST Antenna Tower	AT-100	0203	NA
CHANCE MOST Turn Table	TT-100	0203	NA

- Note: 1. The calibration interval of the above test instruments is 12 months (36 months for Biconical and Periodic Antenna) and the calibrations are traceable to NML/ROC and NIST/USA.
2. The horn antenna, HP preamplifier (model: 8449B) and Spectrum Analyzer (model: R3271A) are used only for the measurement of emission frequency above 1GHz if tested.
 3. The test was performed in ADT Open Site No. C.
 4. The FCC Site Registration No. is 656396.
 5. The VCCI Site Registration No. is R-1626.
 6. The CANADA Site Registration No. is IC 4824A-3.
 7. Loop antenna was used for all emissions below 30 MHz.

4.2.3 TEST PROCEDURES

- a. The EUT was placed on the top of a rotating table 0.8 meters above the ground at a 10 meter open area test site. The table was rotated 360 degrees to determine the position of the highest radiation.
- b. The EUT was set 3 meters away from the interference-receiving antenna, which was mounted on the top of a variable-height antenna tower.
- c. The antenna is a broadband antenna, and its height is varied from one meter to four meters above the ground to determine the maximum value of the field strength. Both horizontal and vertical polarizations of the antenna are set to make the measurement.
- d. For each suspected emission, the EUT was arranged to its worst case and then the antenna was tuned to heights from 1 meter to 4 meters and the rotatable table was turned from 0 degrees to 360 degrees to find the maximum reading.
- e. The test-receiver system was set to Peak Detect Function and Specified Bandwidth with Maximum Hold Mode.
- f. If the emission level of the EUT in peak mode was 10 dB lower than the limit specified, then testing could be stopped and the peak values of the EUT would be reported. Otherwise the emissions that did not have 10 dB margin would be re-tested one by one using peak, quasi-peak or average method as specified and then reported in a data sheet.

NOTE:

1. The resolution bandwidth and video bandwidth of test receiver/spectrum analyzer is 120kHz for Peak detection (PK) and Quasi-peak detection (QP) at frequency below 1GHz.
2. The resolution bandwidth and video bandwidth of test receiver/spectrum analyzer is 1 MHz for Peak detection at frequency above 1GHz.
3. The resolution bandwidth of test receiver/spectrum analyzer is 1 MHz and the video bandwidth is 10 Hz for Average detection (AV) at frequency above 1GHz.

4.2.4 TEST SETUP

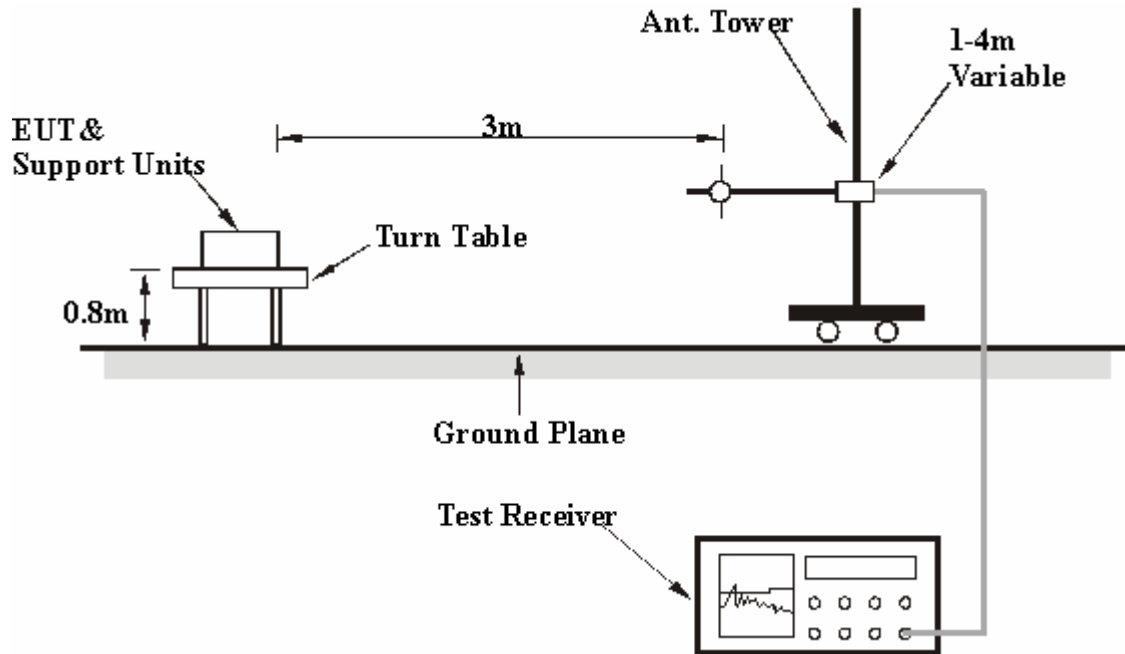

For the actual test configuration, please refer to the related item – Photographs of the Test Configuration.

4.2.5 EUT OPERATING CONDITIONS

Same as 4.1.5

4.2.6 TEST RESULTS

Below 1GHz Worst-Case Data

MODULATION TYPE	CCK	CHANNEL	CH11
INPUT POWER (SYSTEM)	120Vac, 60 Hz	FREQUENCY RANGE	30-1000 MHz
ENVIRONMENTAL CONDITIONS	27deg. C, 66%RH, 962hPa	TRANSFER RATE	1Mbps
DETECTOR FUNCTION	Quasi-Peak, 120kHz	TEST MODE	Mode A
TESTED BY	Phoenix Huang		

ANTENNA POLARITY & TEST DISTANCE: HORIZONTAL AT 3 M

No.	Freq. (MHz)	Emission Level (dBuV/m)	Limit (dBuV/m)	Margin (dB)	Antenna Height (m)	Table Angle (Degree)	Raw Value (dBuV)	Correction Factor (dB/m)
1	79.86	28.45 QP	40.00	-11.55	1.76 H	317	18.28	10.17
2	132.00	33.05 QP	43.50	-10.45	1.41 H	83	20.26	12.79
3	165.00	34.17 QP	43.50	-9.33	1.81 H	91	20.32	13.85
4	250.01	37.59 QP	46.00	-8.41	1.00 H	280	23.81	13.78
5	396.01	41.52 QP	46.00	-4.48	1.00 H	149	22.63	18.89
6	500.03	34.69 QP	46.00	-11.31	1.00 H	7	12.93	21.76
7	594.01	36.51 QP	46.00	-9.49	1.59 H	222	12.18	24.33
8	660.01	36.41 QP	46.00	-9.59	1.40 H	105	11.23	25.18
9	924.02	35.84 QP	46.00	-10.16	1.66 H	42	6.50	29.34

ANTENNA POLARITY & TEST DISTANCE: VERTICAL AT 3 M

No.	Freq. (MHz)	Emission Level (dBuV/m)	Limit (dBuV/m)	Margin (dB)	Antenna Height (m)	Table Angle (Degree)	Raw Value (dBuV)	Correction Factor (dB/m)
1	69.02	35.65 QP	40.00	-4.35	1.00 V	73	22.97	12.68
2	80.15	37.57 QP	40.00	-2.43	1.00 V	214	27.46	10.11
3	132.14	34.87 QP	43.50	-8.63	1.00 V	95	22.07	12.80
4	165.00	32.14 QP	43.50	-11.36	1.00 V	207	18.29	13.85
5	300.13	34.02 QP	46.00	-11.98	1.00 V	193	17.19	16.83
6	396.01	38.71 QP	46.00	-7.29	1.19 V	33	19.82	18.89
7	500.30	36.67 QP	46.00	-9.33	1.19 V	349	14.90	21.77
8	750.40	37.53 QP	46.00	-8.47	1.39 V	155	10.18	27.35
9	924.02	35.73 QP	46.00	-10.27	1.31 V	49	6.39	29.34

- REMARKS:**
1. Emission level(dBuV/m)=Raw Value(dBuV) + Correction Factor(dB/m)
 2. Correction Factor(dB/m) = Antenna Factor (dB/m) + Cable Factor (dB)
 3. The other emission levels were very low against the limit.
 4. Margin value = Emission level – Limit value.

MODULATION TYPE	CCK	CHANNEL	CH11
INPUT POWER (SYSTEM)	120Vac, 60 Hz	FREQUENCY RANGE	30-1000 MHz
ENVIRONMENTAL CONDITIONS	27deg. C, 66%RH, 962hPa	TRANSFER RATE	1Mbps
DETECTOR FUNCTION	Quasi-Peak, 120kHz	TEST MODE	Mode B
TESTED BY	Phoenix Huang		

ANTENNA POLARITY & TEST DISTANCE: HORIZONTAL AT 3 M

No.	Freq. (MHz)	Emission Level (dBuV/m)	Limit (dBuV/m)	Margin (dB)	Antenna Height (m)	Table Angle (Degree)	Raw Value (dBuV)	Correction Factor (dB/m)
1	79.71	30.10 QP	40.00	-9.90	1.54 H	276	19.89	10.21
2	132.00	32.58 QP	43.50	-10.92	1.54 H	230	19.79	12.79
3	165.00	41.76 QP	43.50	-1.74	1.69 H	187	27.91	13.85
4	198.01	32.39 QP	43.50	-11.11	1.18 H	172	20.65	11.74
5	300.30	40.23 QP	46.00	-5.77	1.00 H	80	23.40	16.83
6	500.03	38.52 QP	46.00	-7.48	1.60 H	317	16.76	21.76
7	594.01	36.57 QP	46.00	-9.43	1.51 H	308	12.24	24.33
8	660.02	38.14 QP	46.00	-7.86	1.36 H	18	12.96	25.18
9	924.02	38.85 QP	46.00	-7.15	1.00 H	25	9.51	29.34

ANTENNA POLARITY & TEST DISTANCE: VERTICAL AT 3 M

No.	Freq. (MHz)	Emission Level (dBuV/m)	Limit (dBuV/m)	Margin (dB)	Antenna Height (m)	Table Angle (Degree)	Raw Value (dBuV)	Correction Factor (dB/m)
1	79.73	35.71 QP	40.00	-4.29	1.00 V	1	25.50	10.21
2	132.00	35.17 QP	43.50	-8.33	1.00 V	254	22.38	12.79
3	165.00	39.98 QP	43.50	-3.52	1.00 V	51	26.13	13.85
4	198.00	29.69 QP	43.50	-13.81	1.00 V	265	17.95	11.74
5	300.31	36.82 QP	46.00	-9.18	1.00 V	1	19.99	16.83
6	359.90	36.34 QP	46.00	-9.66	1.00 V	21	18.64	17.70
7	500.03	37.12 QP	46.00	-8.88	1.09 V	217	15.36	21.76
8	700.04	32.43 QP	46.00	-13.57	1.00 V	262	6.63	25.80
9	924.02	37.60 QP	46.00	-8.40	1.28 V	39	8.26	29.34

- REMARKS:**
1. Emission level(dBuV/m)=Raw Value(dBuV) + Correction Factor(dB/m)
 2. Correction Factor(dB/m) = Antenna Factor (dB/m) + Cable Factor (dB)
 3. The other emission levels were very low against the limit.
 4. Margin value = Emission level – Limit value.

MODULATION TYPE	CCK	CHANNEL	CH11
INPUT POWER (SYSTEM)	120Vac, 60 Hz	FREQUENCY RANGE	30-1000 MHz
ENVIRONMENTAL CONDITIONS	27deg. C, 66%RH, 962hPa	TRANSFER RATE	1Mbps
DETECTOR FUNCTION	Quasi-Peak, 120kHz	TEST MODE	Mode C
TESTED BY	Phoenix Huang		

ANTENNA POLARITY & TEST DISTANCE: HORIZONTAL AT 3 M

No.	Freq. (MHz)	Emission Level (dBuV/m)	Limit (dBuV/m)	Margin (dB)	Antenna Height (m)	Table Angle (Degree)	Raw Value (dBuV)	Correction Factor (dB/m)
1	78.23	30.34 QP	40.00	-9.66	1.61 H	103	19.77	10.57
2	165.00	38.65 QP	43.50	-4.85	1.71 H	57	24.80	13.85
3	198.15	32.01 QP	43.50	-11.49	1.44 H	171	20.28	11.73
4	396.01	43.99 QP	46.00	-2.01	1.00 H	312	25.10	18.89
5	462.20	39.35 QP	46.00	-6.65	1.37 H	272	18.56	20.79
6	500.30	38.76 QP	46.00	-7.24	1.25 H	223	16.99	21.77
7	594.01	39.06 QP	46.00	-6.94	1.29 H	195	14.73	24.33
8	660.40	38.43 QP	46.00	-7.57	1.17 H	183	13.24	25.19
9	750.40	35.41 QP	46.00	-10.59	1.13 H	280	8.06	27.35
10	924.20	39.32 QP	46.00	-6.68	1.00 H	131	9.97	29.35

ANTENNA POLARITY & TEST DISTANCE: VERTICAL AT 3 M

No.	Freq. (MHz)	Emission Level (dBuV/m)	Limit (dBuV/m)	Margin (dB)	Antenna Height (m)	Table Angle (Degree)	Raw Value (dBuV)	Correction Factor (dB/m)
1	68.79	36.94 QP	40.00	-3.06	1.00 V	275	24.23	12.71
2	80.15	37.53 QP	40.00	-2.47	1.00 V	208	27.42	10.11
3	165.09	38.71 QP	43.50	-4.79	1.02 V	231	24.87	13.84
4	198.00	30.30 QP	43.50	-13.20	1.02 V	253	18.56	11.74
5	297.13	33.74 QP	46.00	-12.26	1.13 V	57	17.05	16.69
6	396.01	39.93 QP	46.00	-6.07	1.18 V	37	21.04	18.89
7	500.02	36.43 QP	46.00	-9.57	1.50 V	99	14.67	21.76
8	594.01	34.83 QP	46.00	-11.17	1.38 V	98	10.50	24.33
9	750.40	35.74 QP	46.00	-10.26	1.45 V	229	8.39	27.35
10	924.02	34.02 QP	46.00	-11.98	1.31 V	263	4.68	29.34

- REMARKS:**
1. Emission level(dBuV/m)=Raw Value(dBuV) + Correction Factor(dB/m)
 2. Correction Factor(dB/m) = Antenna Factor (dB/m) + Cable Factor (dB)
 3. The other emission levels were very low against the limit.
 4. Margin value = Emission level – Limit value.

MODULATION TYPE	CCK	CHANNEL	CH11
INPUT POWER (SYSTEM)	120Vac, 60 Hz	FREQUENCY RANGE	30-1000 MHz
ENVIRONMENTAL CONDITIONS	27deg. C, 66%RH, 962hPa	TRANSFER RATE	1Mbps
DETECTOR FUNCTION	Quasi-Peak, 120kHz	TEST MODE	Mode D
TESTED BY	Phoenix Huang		

ANTENNA POLARITY & TEST DISTANCE: HORIZONTAL AT 3 M

No.	Freq. (MHz)	Emission Level (dBuV/m)	Limit (dBuV/m)	Margin (dB)	Antenna Height (m)	Table Angle (Degree)	Raw Value (dBuV)	Correction Factor (dB/m)
1	79.86	30.26 QP	40.00	-9.74	1.77 H	62	20.09	10.17
2	125.87	40.32 QP	43.50	-3.18	1.47 H	167	28.03	12.29
3	144.00	37.26 QP	43.50	-6.24	1.47 H	21	23.69	13.57
4	275.19	38.27 QP	46.00	-7.73	1.51 H	21	22.65	15.62
5	300.30	41.20 QP	46.00	-4.80	1.48 H	280	24.37	16.83
6	500.30	39.01 QP	46.00	-6.99	1.37 H	175	17.24	21.77
7	660.01	33.74 QP	46.00	-12.26	1.29 H	39	8.56	25.18
8	750.40	37.15 QP	46.00	-8.85	1.20 H	314	9.80	27.35
9	924.02	36.79 QP	46.00	-9.21	1.00 H	112	7.45	29.34

ANTENNA POLARITY & TEST DISTANCE: VERTICAL AT 3 M

No.	Freq. (MHz)	Emission Level (dBuV/m)	Limit (dBuV/m)	Margin (dB)	Antenna Height (m)	Table Angle (Degree)	Raw Value (dBuV)	Correction Factor (dB/m)
1	69.24	35.98 QP	40.00	-4.02	1.00 V	152	23.32	12.66
2	79.86	37.20 QP	40.00	-2.80	1.00 V	221	27.03	10.17
3	125.13	33.65 QP	43.50	-9.85	1.00 V	93	21.42	12.23
4	144.00	31.95 QP	43.50	-11.55	1.00 V	1	18.38	13.57
5	200.09	35.41 QP	43.50	-8.09	1.00 V	300	23.81	11.60
6	300.13	36.53 QP	46.00	-9.47	1.00 V	232	19.70	16.83
7	400.30	36.91 QP	46.00	-9.09	1.00 V	95	17.88	19.03
8	500.30	40.32 QP	46.00	-5.68	1.00 V	230	18.55	21.77
9	750.40	35.64 QP	46.00	-10.36	1.41 V	149	8.29	27.35
10	924.20	36.84 QP	46.00	-9.16	1.36 V	242	7.49	29.35

- REMARKS:**
1. Emission level(dBuV/m)=Raw Value(dBuV) + Correction Factor(dB/m)
 2. Correction Factor(dB/m) = Antenna Factor (dB/m) + Cable Factor (dB)
 3. The other emission levels were very low against the limit.
 4. Margin value = Emission level – Limit value.

MODULATION TYPE	CCK	CHANNEL	CH11
INPUT POWER (SYSTEM)	120Vac, 60 Hz	FREQUENCY RANGE	30-1000 MHz
ENVIRONMENTAL CONDITIONS	27deg. C, 66%RH, 962hPa	TRANSFER RATE	1Mbps
DETECTOR FUNCTION	Quasi-Peak, 120kHz	TEST MODE	Mode E
TESTED BY	Phoenix Huang		

ANTENNA POLARITY & TEST DISTANCE: HORIZONTAL AT 3 M

No.	Freq. (MHz)	Emission Level (dBuV/m)	Limit (dBuV/m)	Margin (dB)	Antenna Height (m)	Table Angle (Degree)	Raw Value (dBuV)	Correction Factor (dB/m)
1	79.85	31.25 QP	40.00	-8.75	1.75 H	58	21.07	10.18
2	125.04	41.25 QP	43.50	-2.25	1.44 H	165	29.02	12.23
3	144.05	38.52 QP	43.50	-4.98	1.44 H	236	24.95	13.57
4	275.20	39.85 QP	46.00	-6.15	1.55 H	247	24.23	15.62
5	500.07	41.21 QP	46.00	-4.79	1.33 H	185	19.45	21.76
6	660.05	34.75 QP	46.00	-11.25	1.28 H	311	9.57	25.18
7	750.04	37.28 QP	46.00	-8.72	1.22 H	325	9.93	27.35
8	924.21	37.88 QP	46.00	-8.12	1.00 H	117	8.53	29.35

ANTENNA POLARITY & TEST DISTANCE: VERTICAL AT 3 M

No.	Freq. (MHz)	Emission Level (dBuV/m)	Limit (dBuV/m)	Margin (dB)	Antenna Height (m)	Table Angle (Degree)	Raw Value (dBuV)	Correction Factor (dB/m)
1	70.12	36.52 QP	40.00	-3.48	1.00 V	24	23.98	12.54
2	80.12	37.41 QP	40.00	-2.59	1.00 V	321	27.29	10.12
3	125.13	34.14 QP	43.50	-9.36	1.00 V	99	21.91	12.23
4	144.03	32.52 QP	43.50	-10.98	1.00 V	74	18.95	13.57
5	200.04	36.25 QP	43.50	-7.25	1.00 V	241	24.65	11.60
6	300.12	37.52 QP	46.00	-8.48	1.00 V	223	20.69	16.83
7	400.41	38.12 QP	46.00	-7.88	1.00 V	174	19.09	19.03
8	500.17	41.12 QP	46.00	-4.88	1.41 V	156	19.35	21.77
9	750.18	36.41 QP	46.00	-9.59	1.33 V	154	9.06	27.35
10	924.03	37.52 QP	46.00	-8.48	1.33 V	74	8.17	29.35

- REMARKS:**
1. Emission level(dBuV/m)=Raw Value(dBuV) + Correction Factor(dB/m)
 2. Correction Factor(dB/m) = Antenna Factor (dB/m) + Cable Factor (dB)
 3. The other emission levels were very low against the limit.
 4. Margin value = Emission level – Limit value.

MODULATION TYPE	CCK	CHANNEL	CH11
INPUT POWER (SYSTEM)	120Vac, 60 Hz	FREQUENCY RANGE	30-1000 MHz
ENVIRONMENTAL CONDITIONS	27deg. C, 66%RH, 962hPa	TRANSFER RATE	1Mbps
DETECTOR FUNCTION	Quasi-Peak, 120kHz	TEST MODE	Mode F
TESTED BY	Phoenix Huang		

ANTENNA POLARITY & TEST DISTANCE: HORIZONTAL AT 3 M

No.	Freq. (MHz)	Emission Level (dBuV/m)	Limit (dBuV/m)	Margin (dB)	Antenna Height (m)	Table Angle (Degree)	Raw Value (dBuV)	Correction Factor (dB/m)
1	80.41	31.25 QP	40.00	-8.75	1.75 H	58	21.18	10.07
2	125.32	40.15 QP	43.50	-3.35	1.55 H	47	27.90	12.25
3	144.05	38.24 QP	43.50	-5.26	1.52 H	227	24.67	13.57
4	275.41	39.55 QP	46.00	-6.45	1.48 H	165	23.92	15.63
5	300.21	42.52 QP	46.00	-3.48	1.44 H	275	25.69	16.83
6	660.41	34.25 QP	46.00	-11.75	1.22 H	249	9.06	25.19
7	750.07	38.52 QP	46.00	-7.48	1.22 H	335	11.17	27.35
8	924.02	37.52 QP	46.00	-8.48	1.00 H	241	8.18	29.34

ANTENNA POLARITY & TEST DISTANCE: VERTICAL AT 3 M

No.	Freq. (MHz)	Emission Level (dBuV/m)	Limit (dBuV/m)	Margin (dB)	Antenna Height (m)	Table Angle (Degree)	Raw Value (dBuV)	Correction Factor (dB/m)
1	68.75	36.65 QP	40.00	-3.35	1.00 V	241	23.94	12.71
2	79.85	36.98 QP	40.00	-3.02	1.00 V	155	26.80	10.18
3	144.02	32.52 QP	43.50	-10.98	1.00 V	174	18.95	13.57
4	200.05	36.95 QP	43.50	-6.55	1.00 V	284	25.35	11.60
5	200.11	36.95 QP	43.50	-6.55	1.00 V	285	25.35	11.60
6	300.25	37.74 QP	46.00	-8.26	1.00 V	36	20.91	16.83
7	400.21	38.52 QP	46.00	-7.48	1.00 V	45	19.49	19.03
8	500.01	40.52 QP	46.00	-5.48	1.44 V	274	18.76	21.76
9	924.06	37.52 QP	46.00	-8.48	1.33 V	227	8.17	29.35

- REMARKS:**
1. Emission level(dBuV/m)=Raw Value(dBuV) + Correction Factor(dB/m)
 2. Correction Factor(dB/m) = Antenna Factor (dB/m) + Cable Factor (dB)
 3. The other emission levels were very low against the limit.
 4. Margin value = Emission level – Limit value.



4.2.7 TEST RESULTS - DSSS
802.11b DSSS modulation

CHANNEL	CH11	FREQUENCY RANGE	1000~25000MHz
INPUT POWER (SYSTEM)	120Vac, 60 Hz	DETECTOR FUNCTION & BANDWIDTH	Peak (PK) Average (AV) 1 MHz
ENVIRONMENTAL CONDITIONS	27 deg. C, 60 %RH, 962hPa	TEST MODE	Mode A
TESTED BY	Phoenix Huang		

ANTENNA POLARITY & TEST DISTANCE: HORIZONTAL AT 3 M

No.	Freq. (MHz)	Emission Level (dBuV/m)	Limit (dBuV/m)	Margin (dB)	Antenna Height (m)	Table Angle (Degree)	Raw Value (dBuV)	Correction Factor (dB/m)
1	*2462.00	101.40 PK			1.28 H	95	70.77	30.63
2	*2462.00	95.90 AV			1.28 H	95	65.27	30.63
3	2483.50	56.80 PK	74.00	-17.20	1.28 H	90	26.08	30.72
4	2483.50	45.00 AV	54.00	-9.00	1.28 H	90	14.28	30.72
5	4924.00	54.40 PK	74.00	-19.60	1.66 H	313	18.34	36.06
6	4924.00	50.80 AV	54.00	-3.20	1.66 H	313	14.74	36.06
7	7386.00	53.10 PK	74.00	-20.90	1.51 H	294	11.09	42.01
8	7386.00	41.70 AV	54.00	-12.30	1.51 H	294	-0.31	42.01

ANTENNA POLARITY & TEST DISTANCE: VERTICAL AT 3 M

No.	Freq. (MHz)	Emission Level (dBuV/m)	Limit (dBuV/m)	Margin (dB)	Antenna Height (m)	Table Angle (Degree)	Raw Value (dBuV)	Correction Factor (dB/m)
1	*2462.00	108.50 PK			1.44 V	285	77.87	30.63
2	*2462.00	104.10 AV			1.44 V	285	73.47	30.63
3	2483.50	61.00 PK	74.00	-13.00	1.44 V	285	30.28	30.72
4	2483.50	52.00 AV	54.00	-2.00	1.44 V	285	21.28	30.72
5	4924.00	65.10 PK	74.00	-8.90	1.36 V	351	29.04	36.06
6	4924.00	53.50 AV	54.00	-0.50	1.36 V	351	17.44	36.06
7	7386.00	55.50 PK	74.00	-18.50	1.43 V	247	13.49	42.01
8	7386.00	44.80 AV	54.00	-9.20	1.43 V	247	2.79	42.01

- REMARKS:**
1. Emission level(dBuV/m)=Raw Value(dBuV) + Correction Factor(dB/m)
 2. Correction Factor(dB/m) = Antenna Factor (dB/m) + Cable Factor (dB)
 3. The other emission levels were very low against the limit.
 4. Margin value = Emission level – Limit value.
 5. The limit value is defined as per 15.247
 6. “ * “ : Fundamental frequency

CHANNEL	CH11	FREQUENCY RANGE	1000~25000MHz
INPUT POWER (SYSTEM)	120Vac, 60 Hz	DETECTOR FUNCTION & BANDWIDTH	Peak (PK) Average (AV) 1 MHz
ENVIRONMENTAL CONDITIONS	27 deg. C, 60 %RH, 962hPa	TEST MODE	Mode B
TESTED BY	Phoenix Huang		

ANTENNA POLARITY & TEST DISTANCE: HORIZONTAL AT 3 M

No.	Freq. (MHz)	Emission Level (dBuV/m)	Limit (dBuV/m)	Margin (dB)	Antenna Height (m)	Table Angle (Degree)	Raw Value (dBuV)	Correction Factor (dB/m)
1	*2462.00	105.80 PK			1.28 H	94	75.17	30.63
2	*2462.00	100.70 AV			1.28 H	94	70.07	30.63
3	2483.50	56.80 PK	74.00	-17.20	1.28 H	94	26.08	30.72
4	2483.50	44.90 AV	54.00	-9.10	1.28 H	94	14.18	30.72
5	4924.00	54.00 PK	74.00	-20.00	1.70 H	233	17.94	36.06
6	4924.00	50.70 AV	54.00	-3.30	1.70 H	233	14.64	36.06
7	7386.00	53.00 PK	74.00	-21.00	1.20 H	211	10.99	42.01
8	7386.00	42.10 AV	54.00	-11.90	1.20 H	211	0.09	42.01

ANTENNA POLARITY & TEST DISTANCE: VERTICAL AT 3 M

No.	Freq. (MHz)	Emission Level (dBuV/m)	Limit (dBuV/m)	Margin (dB)	Antenna Height (m)	Table Angle (Degree)	Raw Value (dBuV)	Correction Factor (dB/m)
1	*2462.00	108.80 PK			1.00 V	277	78.17	30.63
2	*2462.00	103.54 AV			1.00 V	277	72.91	30.63
3	2484.70	62.00 PK	74.00	-12.00	1.00 V	277	31.28	30.72
4	2484.70	50.40 AV	54.00	-3.60	1.00 V	277	19.68	30.72
5	4924.00	55.80 PK	74.00	-18.20	1.46 V	182	19.74	36.06
6	4924.00	53.10 AV	54.00	-0.90	1.46 V	182	17.04	36.06
7	7386.00	54.60 PK	74.00	-19.40	1.50 V	191	12.59	42.01
8	7386.00	44.30 AV	54.00	-9.70	1.50 V	191	2.29	42.01

- REMARKS:**
1. Emission level(dBuV/m)=Raw Value(dBuV) + Correction Factor(dB/m)
 2. Correction Factor(dB/m) = Antenna Factor (dB/m) + Cable Factor (dB)
 3. The other emission levels were very low against the limit.
 4. Margin value = Emission level – Limit value.
 5. The limit value is defined as per 15.247
 6. “ * “ : Fundamental frequency

CHANNEL	CH11	FREQUENCY RANGE	1000~25000MHz
INPUT POWER (SYSTEM)	120Vac, 60 Hz	DETECTOR FUNCTION & BANDWIDTH	Peak (PK) Average (AV) 1 MHz
ENVIRONMENTAL CONDITIONS	27 deg. C, 60 %RH, 962hPa	TEST MODE	Mode C
TESTED BY	Phoenix Huang		

ANTENNA POLARITY & TEST DISTANCE: HORIZONTAL AT 3 M

No.	Freq. (MHz)	Emission Level (dBuV/m)	Limit (dBuV/m)	Margin (dB)	Antenna Height (m)	Table Angle (Degree)	Raw Value (dBuV)	Correction Factor (dB/m)
1	*2462.00	100.30 PK			1.13 H	267	69.67	30.63
2	*2462.00	94.60 AV			1.13 H	267	63.97	30.63
3	2483.50	57.40 PK	74.00	-16.60	1.12 H	265	26.68	30.72
4	2483.50	45.60 AV	54.00	-8.40	1.12 H	265	14.88	30.72
5	4924.00	53.40 PK	74.00	-20.60	1.52 H	240	17.34	36.06
6	4924.00	49.90 AV	54.00	-4.10	1.52 H	240	13.84	36.06
7	7386.00	53.60 PK	74.00	-20.40	1.70 H	81	11.59	42.01
8	7386.00	42.10 AV	54.00	-11.90	1.70 H	81	0.09	42.01

ANTENNA POLARITY & TEST DISTANCE: VERTICAL AT 3 M

No.	Freq. (MHz)	Emission Level (dBuV/m)	Limit (dBuV/m)	Margin (dB)	Antenna Height (m)	Table Angle (Degree)	Raw Value (dBuV)	Correction Factor (dB/m)
1	*2462.00	108.70 PK			1.43 V	285	78.07	30.63
2	*2462.00	104.30 AV			1.43 V	285	73.67	30.63
3	2483.50	62.90 PK	74.00	-11.10	1.40 V	285	32.18	30.72
4	2483.50	52.70 AV	54.00	-1.30	1.40 V	285	21.98	30.72
5	4924.00	56.10 PK	74.00	-17.90	1.68 V	341	20.04	36.06
6	4924.00	53.40 AV	54.00	-0.60	1.68 V	341	17.34	36.06
7	7386.00	55.60 PK	74.00	-18.40	1.64 V	342	13.59	42.01
8	7386.00	45.50 AV	54.00	-8.50	1.64 V	342	3.49	42.01

- REMARKS:**
1. Emission level(dBuV/m)=Raw Value(dBuV) + Correction Factor(dB/m)
 2. Correction Factor(dB/m) = Antenna Factor (dB/m) + Cable Factor (dB)
 3. The other emission levels were very low against the limit.
 4. Margin value = Emission level – Limit value.
 5. The limit value is defined as per 15.247
 6. “ * “ : Fundamental frequency

CHANNEL	CH11	FREQUENCY RANGE	1000~25000MHz
INPUT POWER (SYSTEM)	120Vac, 60 Hz	DETECTOR FUNCTION & BANDWIDTH	Peak (PK) Average (AV) 1 MHz
ENVIRONMENTAL CONDITIONS	27 deg. C, 60 %RH, 962hPa	TEST MODE	Mode D
TESTED BY	Phoenix Huang		

ANTENNA POLARITY & TEST DISTANCE: HORIZONTAL AT 3 M

No.	Freq. (MHz)	Emission Level (dBuV/m)	Limit (dBuV/m)	Margin (dB)	Antenna Height (m)	Table Angle (Degree)	Raw Value (dBuV)	Correction Factor (dB/m)
1	*2462.00	99.30 PK			1.02 H	81	68.67	30.63
2	*2462.00	93.80 AV			1.02 H	81	63.17	30.63
3	2483.50	57.70 PK	74.00	-16.30	1.01 H	80	26.98	30.72
4	2483.50	44.80 AV	54.00	-9.20	1.01 H	80	14.08	30.72
5	4924.00	53.50 PK	74.00	-20.50	1.54 H	138	17.44	36.06
6	4924.00	49.50 AV	54.00	-4.50	1.54 H	138	13.44	36.06
7	7386.00	53.80 PK	74.00	-20.20	1.42 H	247	11.79	42.01
8	7386.00	41.80 AV	54.00	-12.20	1.42 H	247	-0.21	42.01

ANTENNA POLARITY & TEST DISTANCE: VERTICAL AT 3 M

No.	Freq. (MHz)	Emission Level (dBuV/m)	Limit (dBuV/m)	Margin (dB)	Antenna Height (m)	Table Angle (Degree)	Raw Value (dBuV)	Correction Factor (dB/m)
1	*2462.00	107.80 PK			1.00 V	84	77.17	30.63
2	*2462.00	103.00 AV			1.00 V	84	72.37	30.63
3	2483.50	60.10 PK	74.00	-13.90	1.00 V	84	29.38	30.72
4	2483.50	52.00 AV	54.00	-2.00	1.00 V	84	21.28	30.72
5	4924.00	53.90 PK	74.00	-20.10	1.63 V	32	17.84	36.06
6	4924.00	51.30 AV	54.00	-2.70	1.63 V	32	15.24	36.06
7	7386.00	55.90 PK	74.00	-18.10	1.52 V	248	13.89	42.01
8	7386.00	47.60 AV	54.00	-6.40	1.52 V	248	5.59	42.01

- REMARKS:**
1. Emission level(dBuV/m)=Raw Value(dBuV) + Correction Factor(dB/m)
 2. Correction Factor(dB/m) = Antenna Factor (dB/m) + Cable Factor (dB)
 3. The other emission levels were very low against the limit.
 4. Margin value = Emission level – Limit value.
 5. The limit value is defined as per 15.247
 6. “ * “ : Fundamental frequency



CHANNEL	CH11	FREQUENCY RANGE	1000~25000MHz
INPUT POWER (SYSTEM)	120Vac, 60 Hz	DETECTOR FUNCTION & BANDWIDTH	Peak (PK) Average (AV) 1 MHz
ENVIRONMENTAL CONDITIONS	27 deg. C, 60 %RH, 962hPa	TEST MODE	Mode E
TESTED BY	Phoenix Huang		

ANTENNA POLARITY & TEST DISTANCE: HORIZONTAL AT 3 M

No.	Freq. (MHz)	Emission Level (dBuV/m)	Limit (dBuV/m)	Margin (dB)	Antenna Height (m)	Table Angle (Degree)	Raw Value (dBuV)	Correction Factor (dB/m)
1	*2462.00	100.30 PK			1.36 H	274	69.67	30.63
2	*2462.00	94.50 AV			1.36 H	274	63.87	30.63
3	2483.50	56.80 PK	74.00	-17.20	1.36 H	274	26.08	30.72
4	2483.50	45.00 AV	54.00	-9.00	1.36 H	274	14.28	30.72
5	4924.00	54.10 PK	74.00	-19.90	1.67 H	315	18.04	36.06
6	4924.00	50.80 AV	54.00	-3.20	1.67 H	315	14.74	36.06
7	7386.00	53.80 PK	74.00	-20.20	1.57 H	211	11.79	42.01
8	7386.00	41.90 AV	54.00	-12.10	1.57 H	211	-0.11	42.01

ANTENNA POLARITY & TEST DISTANCE: VERTICAL AT 3 M

No.	Freq. (MHz)	Emission Level (dBuV/m)	Limit (dBuV/m)	Margin (dB)	Antenna Height (m)	Table Angle (Degree)	Raw Value (dBuV)	Correction Factor (dB/m)
1	*2462.00	107.20 PK			1.43 V	63	76.57	30.63
2	*2462.00	102.80 AV			1.43 V	63	72.17	30.63
3	2483.50	60.60 PK	74.00	-13.40	1.44 V	62	29.88	30.72
4	2483.50	50.50 AV	54.00	-3.50	1.44 V	62	19.78	30.72
5	4924.00	55.60 PK	74.00	-18.40	1.36 V	308	19.54	36.06
6	4924.00	53.20 AV	54.00	-0.80	1.36 V	308	17.14	36.06
7	7386.00	55.30 PK	74.00	-18.70	1.21 V	252	13.29	42.01
8	7386.00	45.70 AV	54.00	-8.30	1.21 V	252	3.69	42.01

- REMARKS:**
1. Emission level(dBuV/m)=Raw Value(dBuV) + Correction Factor(dB/m)
 2. Correction Factor(dB/m) = Antenna Factor (dB/m) + Cable Factor (dB)
 3. The other emission levels were very low against the limit.
 4. Margin value = Emission level – Limit value.
 5. The limit value is defined as per 15.247
 6. “ * “ : Fundamental frequency

CHANNEL	CH11	FREQUENCY RANGE	1000~25000MHz
INPUT POWER (SYSTEM)	120Vac, 60 Hz	DETECTOR FUNCTION & BANDWIDTH	Peak (PK) Average (AV) 1 MHz
ENVIRONMENTAL CONDITIONS	27 deg. C, 60 %RH, 962hPa	TEST MODE	Mode F
TESTED BY	Phoenix Huang		

ANTENNA POLARITY & TEST DISTANCE: HORIZONTAL AT 3 M

No.	Freq. (MHz)	Emission Level (dBuV/m)	Limit (dBuV/m)	Margin (dB)	Antenna Height (m)	Table Angle (Degree)	Raw Value (dBuV)	Correction Factor (dB/m)
1	*2462.00	100.50 PK			1.29 H	76	69.87	30.63
2	*2462.00	94.80 AV			1.29 H	76	64.17	30.63
3	2483.50	56.50 PK	74.00	-17.50	1.29 H	76	25.78	30.72
4	2483.50	45.10 AV	54.00	-8.90	1.29 H	76	14.38	30.72
5	4924.00	50.30 PK	74.00	-23.70	1.69 H	66	14.24	36.06
6	4924.00	45.10 AV	54.00	-8.90	1.69 H	66	9.04	36.06
7	7386.00	53.70 PK	74.00	-20.30	1.35 H	243	11.69	42.01
8	7386.00	41.50 AV	54.00	-12.50	1.35 H	243	-0.51	42.01

ANTENNA POLARITY & TEST DISTANCE: VERTICAL AT 3 M

No.	Freq. (MHz)	Emission Level (dBuV/m)	Limit (dBuV/m)	Margin (dB)	Antenna Height (m)	Table Angle (Degree)	Raw Value (dBuV)	Correction Factor (dB/m)
1	*2462.00	108.30 PK			1.40 V	87	77.67	30.63
2	*2462.00	104.20 AV			1.40 V	87	73.57	30.63
3	2483.50	58.50 PK	74.00	-15.50	1.39 V	90	27.78	30.72
4	2483.50	51.50 AV	54.00	-2.50	1.39 V	90	20.78	30.72
5	4924.00	55.50 PK	74.00	-18.50	1.35 V	319	19.44	36.06
6	4924.00	52.50 AV	54.00	-1.50	1.35 V	319	16.44	36.06
7	7386.00	56.80 PK	74.00	-17.20	1.77 V	339	14.79	42.01
8	7386.00	47.30 AV	54.00	-6.70	1.77 V	339	5.29	42.01

- REMARKS:**
1. Emission level(dBuV/m)=Raw Value(dBuV) + Correction Factor(dB/m)
 2. Correction Factor(dB/m) = Antenna Factor (dB/m) + Cable Factor (dB)
 3. The other emission levels were very low against the limit.
 4. Margin value = Emission level – Limit value.
 5. The limit value is defined as per 15.247
 6. “ * “ : Fundamental frequency

5 PHOTOGRAPHS OF THE TEST CONFIGURATION CONDUCTED EMISSION TEST (Mode A)

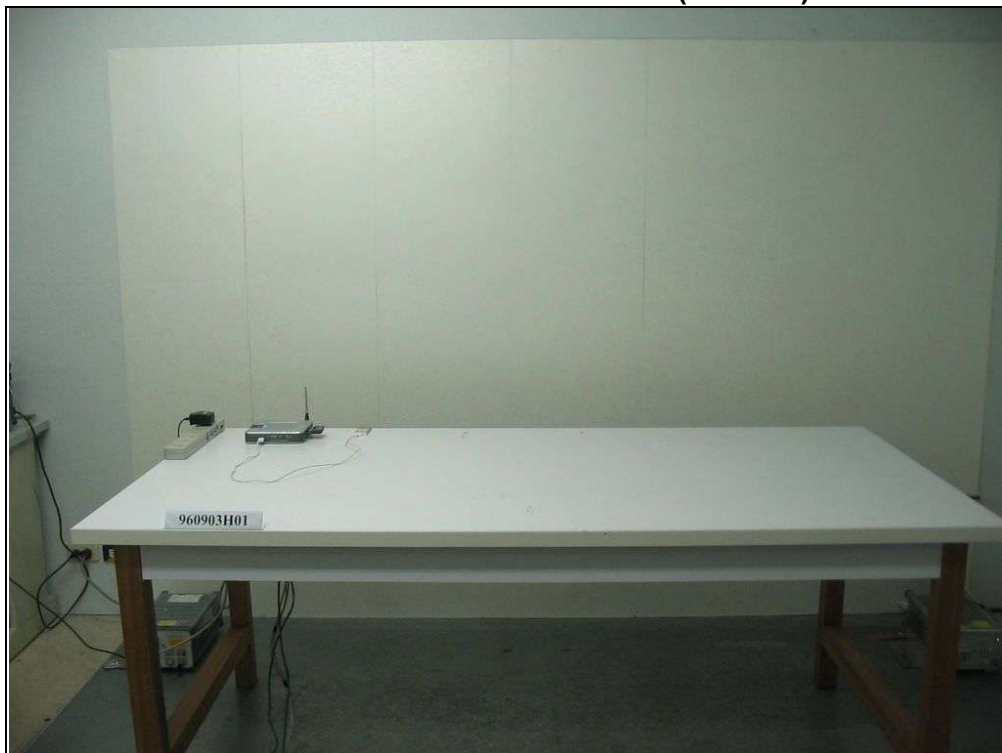

CONDUCTED EMISSION TEST (Mode E)



RADIATED EMISSION TEST (Mode A)



RADIATED EMISSION TEST (Mode B)

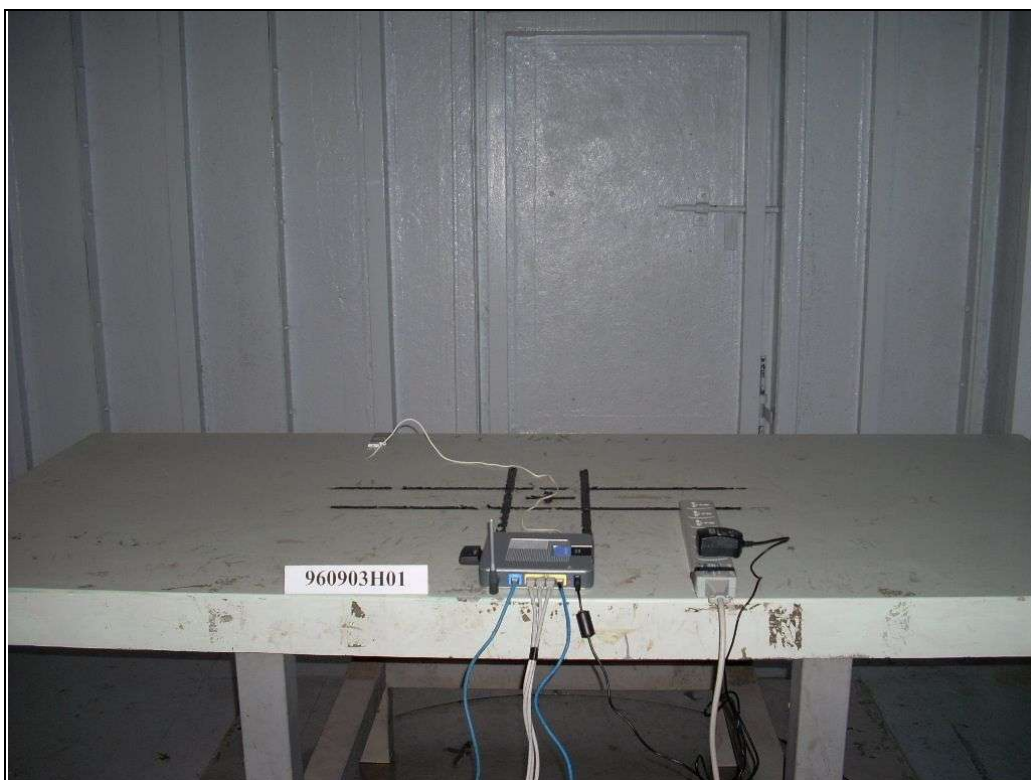

RADIATED EMISSION TEST (Mode C)



RADIATED EMISSION TEST (Mode D)



RADIATED EMISSION TEST (Mode E)



RADIATED EMISSION TEST (Mode F)

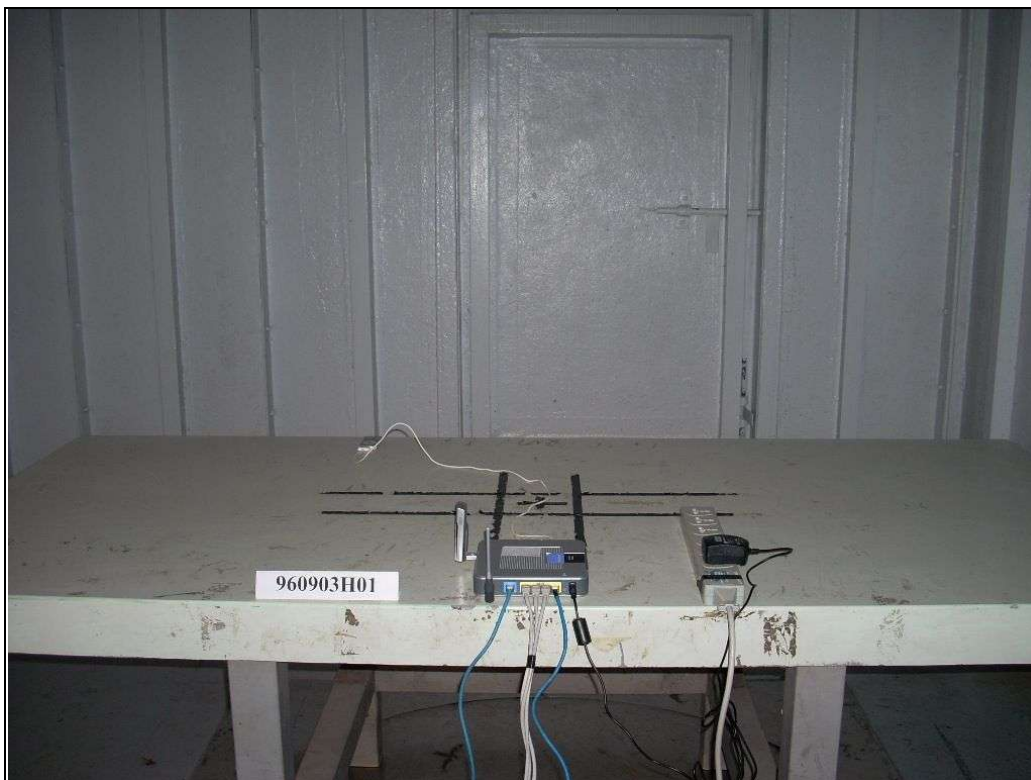



6 INFORMATION ON THE TESTING LABORATORIES

We, ADT Corp., were founded in 1988 to provide our best service in EMC, Radio, Telecom and Safety consultation. Our laboratories are accredited and approved by the following approval agencies according to ISO/IEC 17025:

USA	FCC, UL, A2LA
Germany	TUV Rheinland
Japan	VCCI
Norway	NEMKO
Canada	INDUSTRY CANADA, CSA
R.O.C.	TAF, BSMI, NCC
Netherlands	Telefication
Singapore	GOST-ASIA (MOU)
Russia	CERTIS (MOU)

Copies of accreditation certificates of our laboratories obtained from approval agencies can be downloaded from our web site: www.adt.com.tw/index.5/phtml.

If you have any comments, please feel free to contact us at the following:

Linko EMC/RF Lab:

Tel: 886-2-26052180

Fax: 886-2-26052943

Hsin Chu EMC/RF Lab:

Tel: 886-3-5935343

Fax: 886-3-5935342

Hwa Ya EMC/RF/Safety/Telecom Lab:

Tel: 886-3-3183232

Fax: 886-3-3185050

Email: service@adt.com.tw

Web Site: www.adt.com.tw

The address and road map of all our labs can be found in our web site also.

7 APPENDIX A - MODIFICATIONS RECORDERS FOR ENGINEERING CHANGES TO THE EUT BY THE LAB

No any modifications are made to the EUT by the lab during the test.