



FCC TEST REPORT

REPORT NO.: RF961018H02

MODEL NO.: WRT160N

RECEIVED: Oct. 18, 2007

TESTED: Nov. 06 to 22, 2007

ISSUED: Nov. 22, 2007

APPLICANT: Cisco-Linksys LLC

ADDRESS: 121 Theory Drive Irvine, CA 92617(USA)

ISSUED BY: Advance Data Technology Corporation

TEST LOCATION: No. 81-1, Lu Liao Keng, 9 Ling, Wu Lung
Tsuen, Chiung Lin Hsiang, Hsin Chu Hsien,
Taiwan, R.O.C.

This test report consists of 111 pages in total. It may be duplicated completely for legal use with the approval of the applicant. It should not be reproduced except in full, without the written approval of our laboratory. The client should not use it to claim product endorsement by TAF, A2LA or any government agencies. The test results in the report only apply to the tested sample.



No. 2177-01



Table of Contents

1.	CERTIFICATION	4
2.	SUMMARY OF TEST RESULTS	5
2.1	MEASUREMENT UNCERTAINTY	6
3.	GENERAL INFORMATION	7
3.1	GENERAL DESCRIPTION OF EUT	7
3.2	DESCRIPTION OF TEST MODES	9
3.2.1	TEST MODE APPLICABILITY AND TESTED CHANNEL DETAIL:	10
3.3	GENERAL DESCRIPTION OF APPLIED STANDARDS	14
3.4	DESCRIPTION OF SUPPORT UNITS	15
3.5	CONFIGURATION OF SYSTEM UNDER TEST	16
4.	TEST TYPES AND RESULTS	17
4.1	CONDUCTED EMISSION MEASUREMENT	17
4.1.1	LIMITS OF CONDUCTED EMISSION MEASUREMENT	17
4.1.2	TEST INSTRUMENTS	17
4.1.3	TEST PROCEDURES	18
4.1.4	DEVIATION FROM TEST STANDARD	18
4.1.5	TEST SETUP	19
4.1.6	EUT OPERATING CONDITIONS	19
4.1.7	TEST RESULTS	20
4.2	RADIATED EMISSION MEASUREMENT	24
4.2.1	LIMITS OF RADIATED EMISSION MEASUREMENT	24
4.2.2	TEST INSTRUMENTS	25
4.2.3	TEST PROCEDURES	26
4.2.4	DEVIATION FROM TEST STANDARD	26
4.2.5	TEST SETUP	27
4.2.6	EUT OPERATING CONDITIONS	27
	Below 1GHz Test Data	28
4.2.7	TEST RESULTS	28
	Above 1GHz Test Data	29
4.2.8	TEST RESULTS	29
4.3	6dB BANDWIDTH MEASUREMENT	57
4.3.1	LIMITS OF 6dB BANDWIDTH MEASUREMENT	57
4.3.2	TEST INSTRUMENTS	57
4.3.3	TEST PROCEDURE	58
4.3.4	DEVIATION FROM TEST STANDARD	58
4.3.5	TEST SETUP	58



4.3.6	EUT OPERATING CONDITIONS.....	58
4.3.7	TEST RESULTS.....	59
4.4	MAXIMUM PEAK OUTPUT POWER.....	73
4.4.1	LIMITS OF MAXIMUM PEAK OUTPUT POWER MEASUREMENT.....	73
4.4.2	INSTRUMENTS.....	73
4.4.3	TEST PROCEDURES.....	74
4.4.4	DEVIATION FROM TEST STANDARD.....	74
4.4.5	TEST SETUP.....	74
4.4.6	EUT OPERATING CONDITIONS.....	74
4.4.7	TEST RESULTS.....	75
4.5	POWER SPECTRAL DENSITY MEASUREMENT.....	77
4.5.1	LIMITS OF POWER SPECTRAL DENSITY MEASUREMENT.....	77
4.5.2	TEST INSTRUMENTS.....	77
4.5.3	TEST PROCEDURE.....	78
4.5.4	DEVIATION FROM TEST STANDARD.....	78
4.5.5	TEST SETUP.....	78
4.5.6	EUT OPERATING CONDITION.....	78
4.5.7	TEST RESULTS.....	79
4.6	BAND EDGES MEASUREMENT.....	93
4.6.1	LIMITS OF BAND EDGES MEASUREMENT.....	93
4.6.2	TEST INSTRUMENTS.....	93
4.6.3	TEST PROCEDURE.....	93
4.6.4	DEVIATION FROM TEST STANDARD.....	94
4.6.5	EUT OPERATING CONDITION.....	94
4.6.6	TEST RESULTS.....	94
4.7	ANTENNA REQUIREMENT.....	109
4.7.1	STANDARD APPLICABLE.....	109
4.7.2	ANTENNA CONNECTED CONSTRUCTION.....	109
5.	INFORMATION ON THE TESTING LABORATORIES.....	110
6.	APPENDIX A - MODIFICATIONS RECORDERS FOR ENGINEERING CHANGES TO THE EUT BY THE LAB.....	111



1. CERTIFICATION

PRODUCT: Wireless-N Broadband Router
BRAND NAME: Linksys
MODEL NO.: WRT160N
TESTED: Nov. 06 to 22, 2007
APPLICANT: Cisco-Linksys LLC
STANDARDS: FCC Part 15, Subpart C (Section 15.247),
ANSI C63.4-2003

The above equipment (Model: WRT160N) has been tested by **Advance Data Technology Corporation**, and found compliance with the requirement of the above standards. The test record, data evaluation & Equipment Under Test (EUT) configurations represented herein are true and accurate accounts of the measurements of the sample's EMC characteristics under the conditions specified in this report.

PREPARED BY : Sunny Wen , **DATE:** Nov. 22, 2007
(Sunny Wen, Specialist)

TECHNICAL ACCEPTANCE : Hank Chung , **DATE:** Nov. 22, 2007
Responsible for RF (Hank Chung, Deputy Manager)

APPROVED BY : May Chen , **DATE:** Nov. 22, 2007
(May Chen, Deputy Manager)

2. SUMMARY OF TEST RESULTS

The EUT has been tested according to the following specifications:

APPLIED STANDARD: FCC Part 15, Subpart C (Section 15.247)			
Standard Section	Test Type and Limit	Result	Remark
15.207	AC Power Conducted Emission	PASS	Meet the requirement of limit. Minimum passing margin is -3.26dB at 0.189MHz
15.247(a)(2)	Spectrum Bandwidth of a Direct Sequence Spread Spectrum System Limit: min. 500kHz	PASS	Meet the requirement of limit.
15.247(b)	Maximum Peak Output Power Limit: max. 30dBm	PASS	Meet the requirement of limit.
15.247(d)	Radiated Emissions Limit: Table 15.209	PASS	Meet the requirement of limit. Minimum passing margin is -0.50dB at 4844.00MHz
15.247(e)	Power Spectral Density Limit: max. 8dBm	PASS	Meet the requirement of limit.
15.247(d)	Band Edge Measurement Limit: 20dB less than the peak value of fundamental frequency	PASS	Meet the requirement of limit.

2.1 MEASUREMENT UNCERTAINTY

Where relevant, the following measurement uncertainty levels have been estimated for tests performed on the EUT as specified in CISPR 16-4:

This uncertainty represents an expanded uncertainty expressed at approximately the 95% confidence level using a coverage factor of $k=2$.

Measurement	Value
Conducted emissions	2.44 dB
Radiated emissions (30MHz-1GHz)	3.94 dB
Radiated emissions (1GHz -18GHz)	2.33 dB
Radiated emissions (18GHz -40GHz)	2.55 dB

3. GENERAL INFORMATION

3.1 GENERAL DESCRIPTION OF EUT

PRODUCT	Wireless-N Broadband Router
MODEL NO.	WRT160N
FCC ID	Q87-WRT160N
POWER SUPPLY	DC 12V from power adapter
MODULATION TYPE	CCK, DQPSK, DBPSK for DSSS 64QAM, 16QAM, QPSK, BPSK for OFDM
MODULATION TECHNOLOGY	DSSS, OFDM
TRANSFER RATE	802.11b: 11 / 5.5 / 2 / 1Mbps 802.11g: 54 / 48 / 36 / 24 / 18 / 12 / 9 / 6Mbps Draft 802.11n (20MHz): 130 / 117 / 104 / 78 / 65 / 58.5 / 52 / 39 / 26 / 19.5 / 13 / 6.5Mbps Draft 802.11n (40MHz): 270 / 243 / 216 / 162 / 135 / 121.5 / 108 / 81 / 54 / 40.5 / 27 / 13.5Mbps
FREQUENCY RANGE	802.11b & 802.11g: 2412 ~ 2462MHz
NUMBER OF CHANNEL	11 for 802.11b, 802.11g, draft 802.11n (20MHz) 7 for draft 802.11n (40MHz)
MAXIMUM OUTPUT POWER	802.11b: 186.21mW 802.11g: 428.05mW draft 802.11n (20MHz): 432.57mW draft 802.11n (40MHz): 182.45mW
ANTENNA TYPE	Please see note 1
DATA CABLE	NA
I/O PORT	WAN Port x 1, LAN Port x 4

NOTE:

- There are two antennas provided to this EUT, please refer to the following table:

Transmitter Circuit	Antenna Type	Antenna Connector	Gain(dBi)
Chain(0)	PIFA	NA	1.5
Chain(1)	PIFA	NA	1.5

2. The EUT incorporates a MIMO function with 802.11b, 802.11g, draft 802.11n. Physically, the EUT provides two completed transmit and two completed receivers.
3. The EUT is 2 * 2 spatial MIMO without beam forming function. The antenna configurations are two transmitter antennas and two receiver antennas, as there are 2 PIFA antennas. Spatial multiplexing modes for simultaneous transmission using 2 antennas, and for simultaneous receiver using 2 antennas.
4. When the EUT operating in draft 802.11n, the software operation, which is defined by manufacturer, MCS (Modulation and Coding Schemes) from 0 to 15.
5. The EUT complies with draft 802.11n standards and backwards compatible with 802.11b, 802.11g products.
6. The EUT operates in the 2.4GHz frequency spectrum with data rate up to 270Mbps.
7. The EUT must be supplied with a power adapter and following two different models could be chosen:

Adapter 1	
Brand:	Linksys (ENG)
Model No.:	AD12V/1A-SW
Input power :	AC100-240V, 0.5A, 50-60Hz
Output power :	DC12V, 1A Cable:1.8m/unshielded/without core
Adapter 2	
Brand:	Linksys (ENERTRONIX)
Model No.:	AD12V/1A-SW
Input power :	AC100-240V, 0.5A, 50-60Hz
Output power :	DC12V, 1A Cable:1.8m/unshielded/without core

8. The EUT, operates in the 2.4GHz frequency range, lets you connect IEEE 802.11g or IEEE 802.11b and draft 802.11n technique devices to the network.
9. The above EUT information was declared by manufacturer and for more detailed features description, please refer to the manufacturer's specifications or user's manual.

3.2 DESCRIPTION OF TEST MODES

Eleven channels are provided for 802.11b, 802.11g, draft 802.11n (20MHz):

CHANNEL	FREQUENCY	CHANNEL	FREQUENCY
1	2412MHz	7	2442MHz
2	2417MHz	8	2447MHz
3	2422MHz	9	2452MHz
4	2427MHz	10	2457MHz
5	2432MHz	11	2462MHz
6	2437MHz		

Seven channels are provided for draft 802.11n (40MHz):

CHANNEL	FREQUENCY	CHANNEL	FREQUENCY
1	2422MHz	5	2442MHz
2	2427MHz	6	2447MHz
3	2432MHz	7	2452MHz
4	2437MHz		

3.2.1 TEST MODE APPLICABILITY AND TESTED CHANNEL DETAIL:

EUT CONFIGURE MODE	APPLICABLE TO				DESCRIPTION
	PLC	RE < 1G	RE ≥ 1G	APCM	
-	√	√	√	√	-

Where **PLC**: Power Line Conducted Emission

RE < 1G: Radiated Emission below 1GHz

RE ≥ 1G: Radiated Emission above 1GHz

APCM: Antenna Port Conducted Measurement

ANTENNA COMBINATION MODE:

COMBINATION MODE	OPERATION MODE	TX CHAIN(0)	TX CHAIN(1)
A	802.11 b	√	
B	802.11 g	√	
C		√	√
D	DRAFT 802.11n(20MHz)	√	
E		√	√
F	DRAFT 802.11n(40MHz)	√	
G		√	√

Note:

1. The above information was declared by manufacturer and for more detailed features description, please refer to the manufacturer's specifications or user's manual.
2. From above mode, the different modes were chosen for pretest.
3. Mode A, C, E, G the worst modes, was selected as representative mode for the report.

POWER LINE CONDUCTED EMISSION TEST:

- Pre-Scan has been conducted to determine the worst-case mode from all possible combinations between available modulations, data rates and antenna ports (if EUT with antenna diversity architecture).
- Following channel(s) was (were) selected for the final test as listed below.

MODE	AVAILABLE CHANNEL	TESTED CHANNEL	MODULATION TECHNOLOGY	MODULATION TYPE	DATA RATE (Mbps)	TX COMBINATION
802.11n	1 to 11	1	OFDM	BPSK	6.5	E

- For conducted emissions, the EUT was tested as the following test modes:

Test Mode	Description
Mode A	Adapter 1
Mode B	Adapter 2

RADIATED EMISSION TEST (BELOW 1 GHz):

- Pre-Scan has been conducted to determine the worst-case mode from all possible combinations between available modulations, data rates and antenna ports (if EUT with antenna diversity architecture).
- Following channel(s) was (were) selected for the final test as listed below.

MODE	AVAILABLE CHANNEL	TESTED CHANNEL	MODULATION TECHNOLOGY	MODULATION TYPE	DATA RATE (Mbps)	TX COMBINATION
802.11b	1 to 11	1	DSSS	DBPSK	1	A

- For spurious emissions, the EUT was pre-tested in chamber as the following test modes:

Test Mode	Description
Mode A	Adapter 1
Mode B	Adapter 2

The worst adapter was found in Adapter 1. Their test data were recorded in this report individually.

RADIATED EMISSION TEST (ABOVE 1 GHz):

- Pre-Scan has been conducted to determine the worst-case mode from all possible combinations between available modulations, data rates and antenna ports (if EUT with antenna diversity architecture).
- Following channel(s) was (were) selected for the final test as listed below.

MODE	AVAILABLE CHANNEL	TESTED CHANNEL	MODULATION TECHNOLOGY	MODULATION TYPE	DATA RATE (Mbps)	TX COMBINATION
802.11b	1 to 11	1, 6, 11	DSSS	DBPSK	1	A
802.11g	1 to 11	1, 6, 11	OFDM	BPSK	6	C
Draft 802.11n (20MHz)	1 to 11	1, 6, 11	OFDM	BPSK	6.5	E
Draft 802.11n (40MHz)	1 to 7	1, 4, 7	OFDM	BPSK	13.5	G

- For spurious emissions, the EUT was pre-tested in chamber as the following test modes:

Test Mode	Description
Mode A	Adapter 1
Mode B	Adapter 2

The worst adapter was found in Adapter 1. Their test data were recorded in this report individually.

BANDEDGE MEASUREMENT:

- Pre-Scan has been conducted to determine the worst-case mode from all possible combinations between available modulations, data rates and antenna ports (if EUT with antenna diversity architecture).
- Following channel(s) was (were) selected for the final test as listed below.

MODE	AVAILABLE CHANNEL	TESTED CHANNEL	MODULATION TECHNOLOGY	MODULATION TYPE	DATA RATE (Mbps)	TX COMBINATION
802.11b	1 to 11	1, 11	DSSS	DBPSK	1	A
802.11g	1 to 11	1, 11	OFDM	BPSK	6	C
Draft 802.11n (20MHz)	1 to 11	1, 11	OFDM	BPSK	6.5	E
Draft 802.11n (40MHz)	1 to 7	1, 7	OFDM	BPSK	13.5	G

ANTENNA PORT CONDUCTED MEASUREMENT:

- Pre-Scan has been conducted to determine the worst-case mode from all possible combinations between available modulations, data rates and antenna ports (if EUT with antenna diversity architecture).
- Following channel(s) was (were) selected for the final test as listed below.

MODE	AVAILABLE CHANNEL	TESTED CHANNEL	MODULATION TECHNOLOGY	MODULATION TYPE	DATA RATE (Mbps)	TX COMBINATION
802.11b	1 to 11	1, 6, 11	DSSS	CCK	11	A
802.11g	1 to 11	1, 6, 11	OFDM	BPSK	6	C
Draft 802.11n (20MHz)	1 to 11	1, 6, 11	OFDM	BPSK	6.5	E
Draft 802.11n (40MHz)	1 to 7	1, 4, 7	OFDM	BPSK	13.5	G



3.3 GENERAL DESCRIPTION OF APPLIED STANDARDS

The EUT is a Wireless-N Broadband Router. According to the specifications of the manufacturer, it must comply with the requirements of the following standards:

FCC Part 15, Subpart C. (15.247)

ANSI C63.4-2003

All test items have been performed and recorded as per the above standards.

NOTE: The EUT is also considered as a kind of computer peripheral, because the connection to computer is necessary for typical use. It has been verified to comply with the requirements of FCC Part 15, Subpart B, Class B (DoC). The test report has been issued separately.



3.4 DESCRIPTION OF SUPPORT UNITS

The EUT has been tested as an independent unit together with other necessary accessories or support units. The following support units or accessories were used to form a representative test configuration during the tests.

NO.	PRODUCT	BRAND	MODEL NO.	SERIAL NO.	FCC ID
1	NOTEBOOK COMPUTER	DELL	PP18L	6976685584	FCC Doc
2	NOTEBOOK COMPUTER	DELL	PP19L	CN-OHC416-70166-5CA-0448	PIW632500516610
3	HUB	AVSYS	110H8	01-20E-000002	DoC

NO.	SIGNAL CABLE DESCRIPTION OF THE ABOVE SUPPORT UNITS
1	NA
2	NA
3	NA

NOTE: All power cords of the above support units are non shielded (1.8m).

3.5 CONFIGURATION OF SYSTEM UNDER TEST

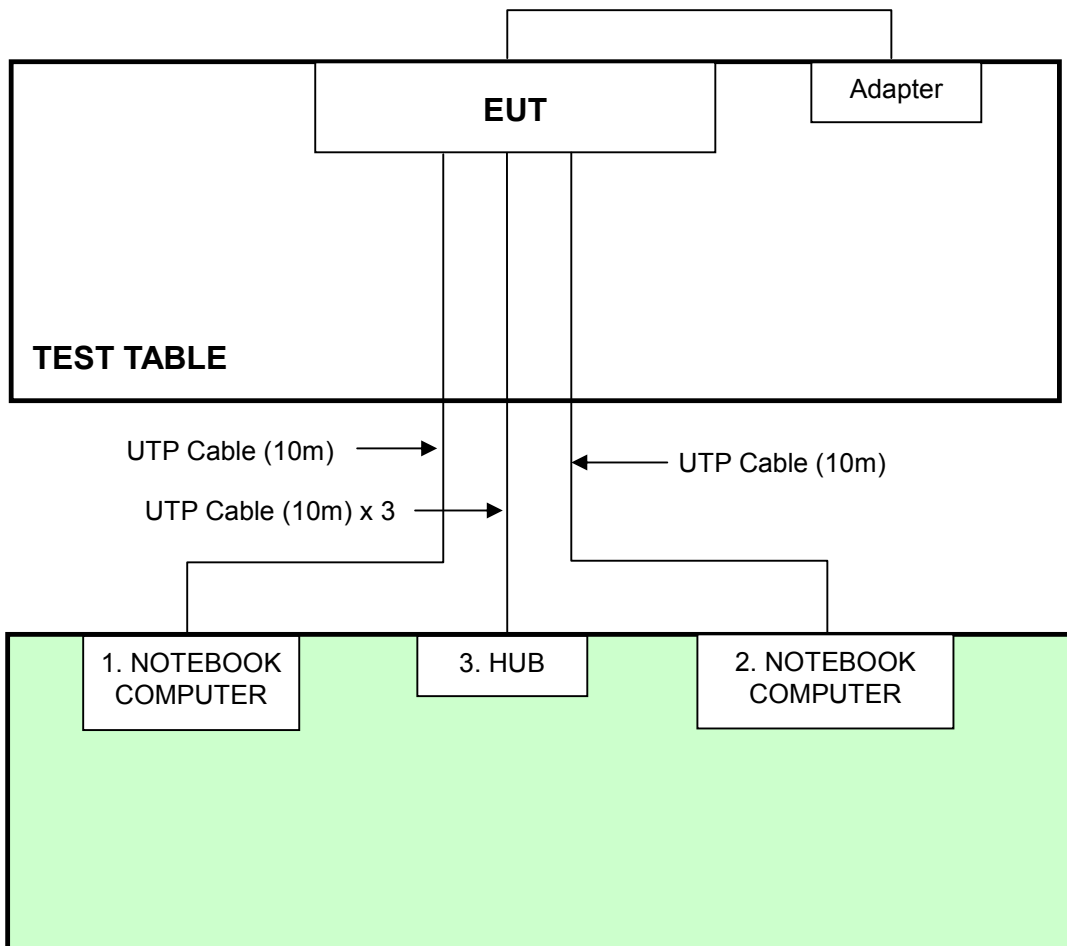

4. TEST TYPES AND RESULTS

4.1 CONDUCTED EMISSION MEASUREMENT

4.1.1 LIMITS OF CONDUCTED EMISSION MEASUREMENT

FREQUENCY OF EMISSION (MHz)	CONDUCTED LIMIT (dB μ V)	
	Quasi-peak	Average
0.15-0.5	66 to 56	56 to 46
0.5-5	56	46
5-30	60	50

- NOTE:**
1. The lower limit shall apply at the transition frequencies.
 2. The limit decreases in line with the logarithm of the frequency in the range of 0.15 to 0.50 MHz.
 3. All emanations from a class A/B digital device or system, including any network of conductors and apparatus connected thereto, shall not exceed the level of field strengths specified above.

4.1.2 TEST INSTRUMENTS

DESCRIPTION & MANUFACTURER	MODEL NO.	SERIAL NO.	CALIBRATED UNTIL
ROHDE & SCHWARZ Test Receiver	ESCS 30	100287	Mar. 06, 2008
Line-Impedance Stabilization Network(for EUT)	ENV-216	100072	Nov. 08, 2008
Line-Impedance Stabilization Network(for Peripheral)	KNW-407	8-1395-12	Aug. 19, 2008
RF Cable (JETBAO)	RG5B/U-6m	COACAB-9KHz-3 0MHz	Aug. 15, 2008
Terminator	50	1	Oct. 30, 2008
Software	ADT_Cond_V7.3.2	NA	NA

- NOTE:**
1. The calibration interval of the above test instruments is 12 months and the calibrations are traceable to NML/ROC and NIST/USA.
 2. The test was performed in ADT Shielded Room No. A.
 3. The VCCI Con A Registration No. is C-817.

4.1.3 TEST PROCEDURES

- a. The EUT was placed 0.4 meters from the conducting wall of the shielded room with EUT being connected to the power mains through a line impedance stabilization network (LISN). Other support units were connected to the power mains through another LISN. The two LISNs provide 50 ohm/ 50uH of coupling impedance for the measuring instrument.
- b. Both lines of the power mains connected to the EUT were checked for maximum conducted interference.
- c. The frequency range from 150kHz to 30MHz was searched. Emission levels under (Limit - 20dB) were not recorded.

4.1.4 DEVIATION FROM TEST STANDARD

No deviation

4.1.5 TEST SETUP

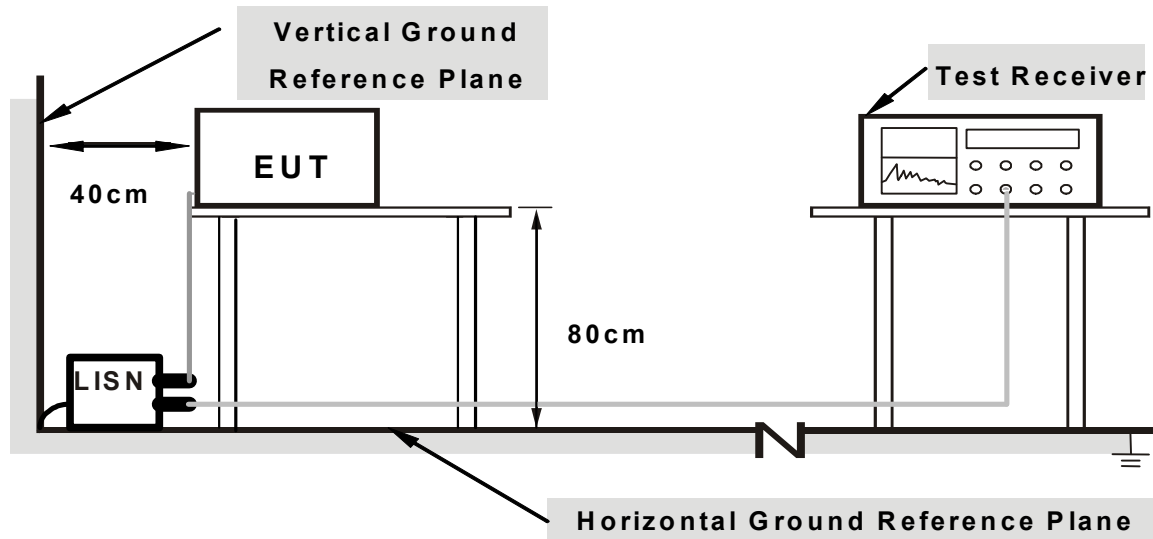

Note: 1. Support units were connected to second LISN.

2. Both of LISNs (AMN) are 80 cm from EUT and at least 80 from other units and other metal planes

For the actual test configuration, please refer to the related item – Photographs of the Test Configuration.

4.1.6 EUT OPERATING CONDITIONS

1. Placed the EUT on testing table.
2. Prepared other computer systems (support unit 1 ~ 2) to act as communication partners and placed them outside of testing area.
3. The communication partners run test program “MFGTEST” to enable EUT under transmission/receiving condition continuously via UTP cables and wireless transmission.

4.1.7 TEST RESULTS

802.11n (20MHz) OFDM MODULATION: WITH ADAPTER 1

EUT TEST CONDITION		MEASUREMENT DETAIL	
CHANNEL	Channel 1	PHASE	Line (L)
MODULATION TYPE	BPSK	6dB BANDWIDTH	9 kHz
TRANSFER RATE	6.5Mbps	INPUT POWER (SYSTEM)	120Vac, 60 Hz
ENVIRONMENTAL CONDITIONS	20deg. C, 62%RH, 955hPa	TESTED BY	Eagle Chen

No	Freq. [MHz]	Corr. Factor (dB)	Reading Value [dB (uV)]		Emission Level [dB (uV)]		Limit [dB (uV)]		Margin (dB)	
			Q.P.	AV.	Q.P.	AV.	Q.P.	AV.	Q.P.	AV.
			1	0.150	0.45	39.00	-	39.45	-	66.00
2	0.408	0.30	47.30	-	47.60	-	57.69	47.69	-10.09	-
3	1.771	0.30	37.24	-	37.54	-	56.00	46.00	-18.46	-
4	3.563	0.38	36.27	-	36.65	-	56.00	46.00	-19.35	-
5	13.266	0.70	32.64	-	33.34	-	60.00	50.00	-26.66	-
6	28.688	1.00	32.08	-	33.08	-	60.00	50.00	-26.92	-

- REMARKS:**
1. Q.P. and AV. are abbreviations of quasi-peak and average individually.
 2. "-": The Quasi-peak reading value also meets average limit and measurement with the average detector is unnecessary.
 3. The emission levels of other frequencies were very low against the limit.
 4. Margin value = Emission level - Limit value
 5. Correction factor = Insertion loss + Cable loss
 6. Emission Level = Correction Factor + Reading Value.

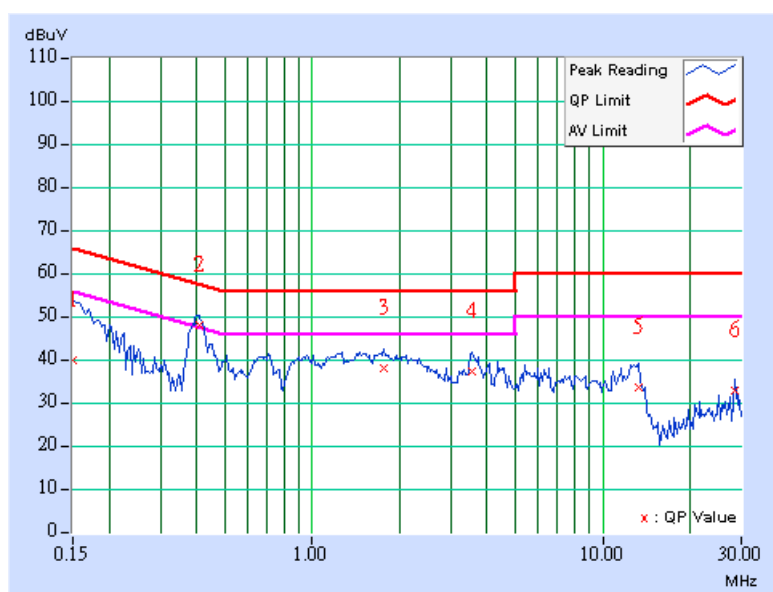

EUT TEST CONDITION		MEASUREMENT DETAIL	
CHANNEL	Channel 1	PHASE	Neutral (N)
MODULATION TYPE	BPSK	6dB BANDWIDTH	9 kHz
TRANSFER RATE	6.5Mbps	INPUT POWER (SYSTEM)	120Vac, 60 Hz
ENVIRONMENTAL CONDITIONS	20deg. C, 62%RH, 955hPa	TESTED BY	Eagle Chen

No	Freq. [MHz]	Corr. Factor (dB)	Reading Value [dB (uV)]		Emission Level [dB (uV)]		Limit [dB (uV)]		Margin (dB)	
			Q.P.	AV.	Q.P.	AV.	Q.P.	AV.	Q.P.	AV.
			1	0.170	0.43	35.52	-	35.95	-	64.98
2	0.412	0.30	47.73	40.08	48.03	40.38	57.61	47.61	-9.58	-7.23
3	0.705	0.30	38.21	-	38.51	-	56.00	46.00	-17.49	-
4	1.826	0.38	36.87	-	37.25	-	56.00	46.00	-18.75	-
5	3.621	0.40	37.17	-	37.57	-	56.00	46.00	-18.43	-
6	12.832	0.71	36.72	-	37.43	-	60.00	50.00	-22.57	-

- REMARKS:**
1. Q.P. and AV. are abbreviations of quasi-peak and average individually.
 2. "-": The Quasi-peak reading value also meets average limit and measurement with the average detector is unnecessary.
 3. The emission levels of other frequencies were very low against the limit.
 4. Margin value = Emission level - Limit value
 5. Correction factor = Insertion loss + Cable loss
 6. Emission Level = Correction Factor + Reading Value.

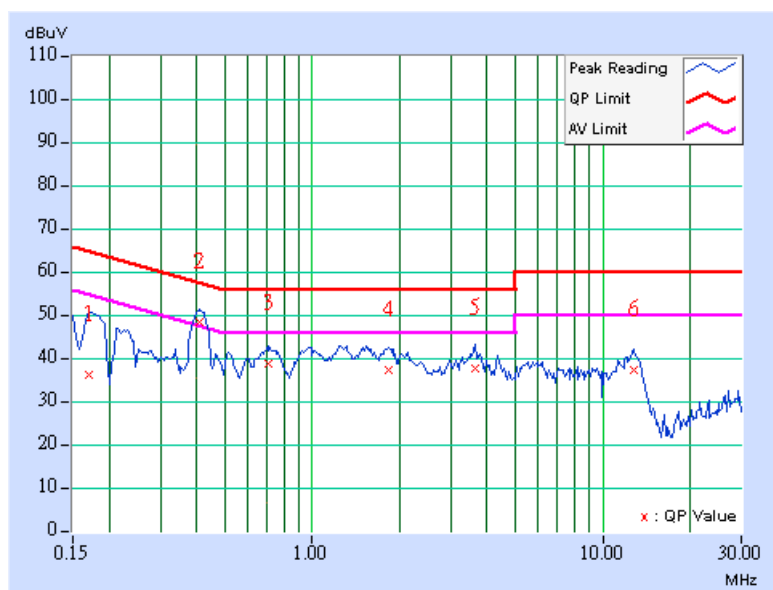

802.11n (20MHz) OFDM MODULATION: WITH ADAPTER 2

EUT TEST CONDITION		MEASUREMENT DETAIL	
CHANNEL	Channel 1	PHASE	Line (L)
MODULATION TYPE	BPSK	6dB BANDWIDTH	9 kHz
TRANSFER RATE	6.5Mbps	INPUT POWER (SYSTEM)	120Vac, 60 Hz
ENVIRONMENTAL CONDITIONS	25deg. C, 65%RH, 962hPa	TESTED BY	Eagle Chen

No	Freq. [MHz]	Corr. Factor (dB)	Reading Value		Emission Level		Limit		Margin	
			[dB (uV)]		[dB (uV)]		[dB (uV)]		(dB)	
			Q.P.	AV.	Q.P.	AV.	Q.P.	AV.	Q.P.	AV.
1	0.189	0.41	58.56	50.41	58.97	50.82	64.08	54.08	-5.11	-3.26
2	0.252	0.37	50.28	-	50.65	-	61.71	51.71	-11.05	-
3	0.314	0.34	42.18	-	42.52	-	59.86	49.86	-17.34	-
4	0.502	0.30	39.86	-	40.16	-	56.00	46.00	-15.84	-
5	4.332	0.41	30.76	-	31.17	-	56.00	46.00	-24.83	-
6	24.348	0.99	37.55	-	38.54	-	60.00	50.00	-21.46	-

- REMARKS:**
1. Q.P. and AV. are abbreviations of quasi-peak and average individually.
 2. "-": The Quasi-peak reading value also meets average limit and measurement with the average detector is unnecessary.
 3. The emission levels of other frequencies were very low against the limit.
 4. Margin value = Emission level - Limit value
 5. Correction factor = Insertion loss + Cable loss
 6. Emission Level = Correction Factor + Reading Value.

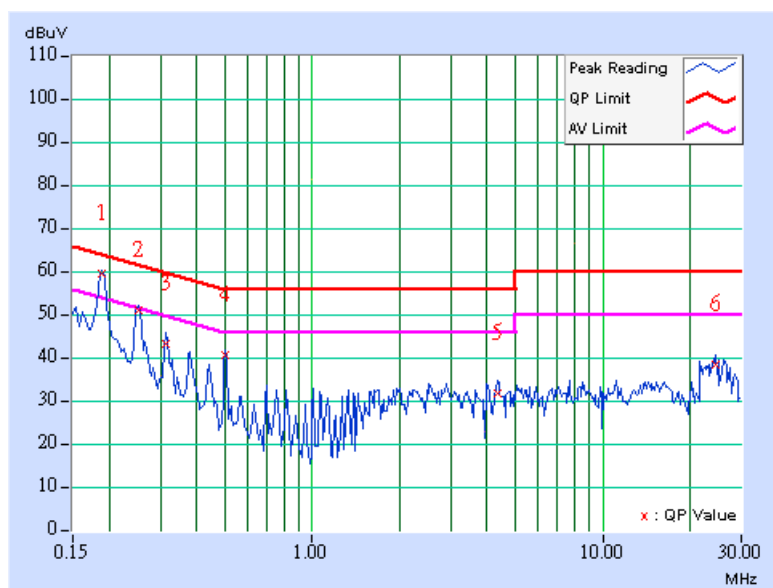

EUT TEST CONDITION		MEASUREMENT DETAIL	
CHANNEL	Channel 1	PHASE	Neutral (N)
MODULATION TYPE	BPSK	6dB BANDWIDTH	9 kHz
TRANSFER RATE	6.5Mbps	INPUT POWER (SYSTEM)	120Vac, 60 Hz
ENVIRONMENTAL CONDITIONS	25deg. C, 65%RH, 962hPa	TESTED BY	Eagle Chen

No	Freq. [MHz]	Corr. Factor (dB)	Reading Value [dB (uV)]		Emission Level [dB (uV)]		Limit [dB (uV)]		Margin (dB)	
			Q.P.	AV.	Q.P.	AV.	Q.P.	AV.	Q.P.	AV.
			1	0.190	0.41	57.91	49.69	58.32	50.10	64.06
2	0.253	0.37	49.41	-	49.78	-	61.66	51.66	-11.87	-
3	0.314	0.34	41.58	-	41.92	-	59.86	49.86	-17.94	-
4	0.505	0.30	39.30	-	39.60	-	56.00	46.00	-16.40	-
5	2.888	0.40	30.71	-	31.11	-	56.00	46.00	-24.89	-
6	21.664	0.93	38.44	-	39.37	-	60.00	50.00	-20.63	-

- REMARKS:**
1. Q.P. and AV. are abbreviations of quasi-peak and average individually.
 2. "-": The Quasi-peak reading value also meets average limit and measurement with the average detector is unnecessary.
 3. The emission levels of other frequencies were very low against the limit.
 4. Margin value = Emission level - Limit value
 5. Correction factor = Insertion loss + Cable loss
 6. Emission Level = Correction Factor + Reading Value.

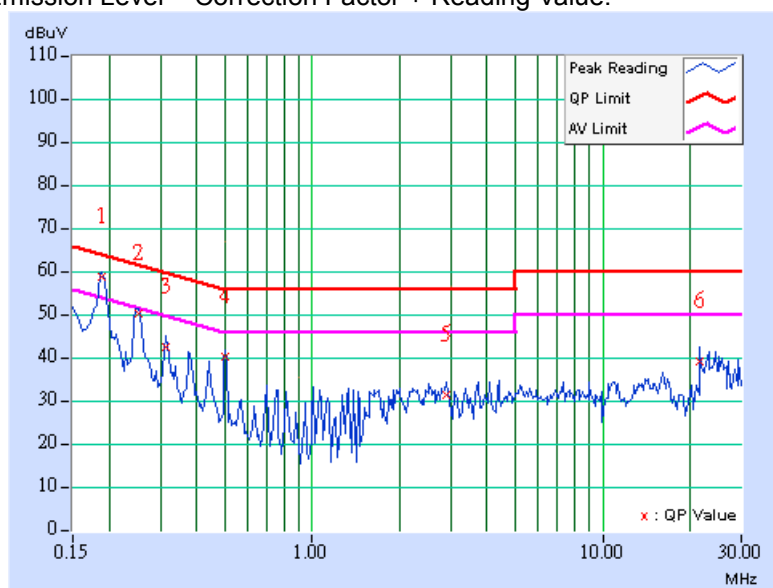

4.2 RADIATED EMISSION MEASUREMENT

4.2.1 LIMITS OF RADIATED EMISSION MEASUREMENT

Emissions radiated outside of the specified bands, shall be according to the general radiated limits in 15.209 as following:

Frequencies (MHz)	Field strength (microvolts/meter)	Measurement distance (meters)
0.009-0.490	2400/F(kHz)	300
0.490-1.705	24000/F(kHz)	30
1.705-30.0	30	30
30-88	100	3
88-216	150	3
216-960	200	3
Above 960	500	3

NOTE:

1. The lower limit shall apply at the transition frequencies.
2. Emission level (dBuV/m) = 20 log Emission level (uV/m).
3. As shown in 15.35(b), for frequencies above 1000MHz, the field strength limits are based on average detector, however, the peak field strength of any emission shall not exceed the maximum permitted average limits, specified above by more than 20dB under any condition of modulation.



4.2.2 TEST INSTRUMENTS

DESCRIPTION & MANUFACTURER	MODEL NO.	SERIAL NO.	CALIBRATED UNTIL
ADVANTEST Spectrum Analyzer	R3271A	85060311	July 15, 2008
HP Pre_Amplifier	8449B	3008A01922	Oct. 04, 2008
ROHDE & SCHWARZ Test Receiver	ESCS30	100375	Mar. 26, 2008
CHASE Broadband Antenna	VULB 9168	138	July 26, 2008
Schwarzbeck Horn_Antenna	BBHA9120	D124	Jan. 01, 2008
Schwarzbeck Horn_Antenna	BBHA 9170	BBHA9170153	Jan. 25, 2008
TRILOG Broad Band Antenna	VULB 9168	138	July 26, 2008
R&S Loop Antenna	HFH2-Z2	881058/15	Nov. 29, 2007
RF Switches (ARNITSU)	CS-201	1565157	Aug. 13, 2008
RF CABLE (Chaintek)	SF102	22054-2	Nov. 14. 2008
RF Cable(RICHTEC)	9913-30M N-N Cable	STCCAB-30M-1 GHz	Aug. 13, 2008
Software	ADT_Radiated_V 7.6.15.7	NA	NA
CHANCE MOST Antenna Tower	AT-100	0203	NA
CHANCE MOST Turn Table	TT-100	0203	NA

- Note: 1. The calibration interval of the above test instruments is 12 months and the calibrations are traceable to NML/ROC and NIST/USA.
 2. The horn antenna, HP preamplifier (model: 8449B) and Spectrum Analyzer (model: R3271A) are used only for the measurement of emission frequency above 1GHz if tested.
 3. The test was performed in ADT Open Site No. C.
 4. The FCC Site Registration No. is 656396.
 5. The VCCI Site Registration No. is R-1626.
 6. The CANADA Site Registration No. is IC 4824A-3.

4.2.3 TEST PROCEDURES

- a. The EUT was placed on the top of a rotating table 0.8 meters above the ground at a 3 meter semi- anechoic. The table was rotated 360 degrees to determine the position of the highest radiation.
- b. The EUT was set 3 meters away from the interference-receiving antenna, which was mounted on the top of a variable-height antenna tower.
- c. The antenna is a broadband antenna, and its height is varied from one meter to four meters above the ground to determine the maximum value of the field strength. Both horizontal and vertical polarizations of the antenna are set to make the measurement.
- d. For each suspected emission, the EUT was arranged to its worst case and then the antenna was tuned to heights from 1 meter to 4 meters and the rotatable table was turned from 0 degrees to 360 degrees to find the maximum reading.
- e. The test-receiver system was set to Peak Detect Function and Specified Bandwidth with Maximum Hold Mode.
- f. If the emission level of the EUT in peak mode was 10 dB lower than the limit specified, then testing could be stopped and the peak values of the EUT would be reported. Otherwise the emissions that did not have 10 dB margin would be re-tested one by one using the quasi-peak method or average method as specified and then reported in Data sheet peak mode and QP mode.

NOTE:

1. The resolution bandwidth and video bandwidth of test receiver/spectrum analyzer is 120kHz for Peak detection (PK) and Quasi-peak detection (QP) at frequency below 1GHz.
2. The resolution bandwidth of test receiver/spectrum analyzer is 1 MHz and the video bandwidth is 3 MHz for Peak detection (PK) at frequency above 1GHz.
3. The resolution bandwidth of test receiver/spectrum analyzer is 1 MHz and the video bandwidth is 10 Hz for Average detection (AV) at frequency above 1GHz.

4.2.4 DEVIATION FROM TEST STANDARD

No deviation

4.2.5 TEST SETUP

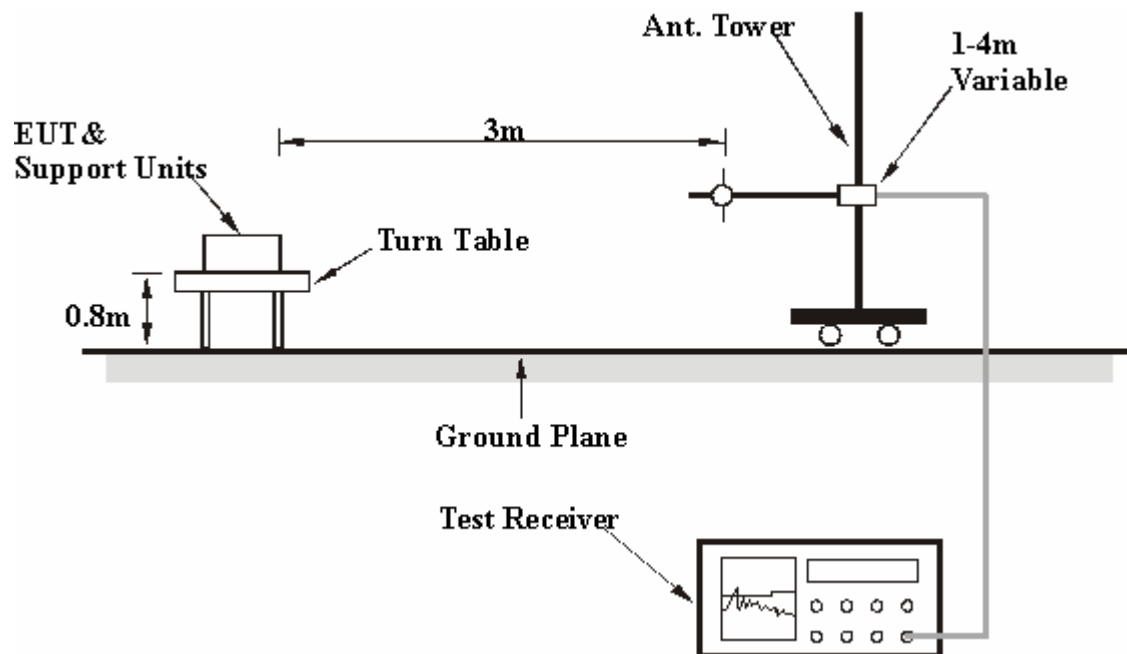

For the actual test configuration, please refer to the related item – Photographs of the Test Configuration.

4.2.6 EUT OPERATING CONDITIONS

1. Placed the EUT on testing table.
2. Prepared other computer systems (support unit 1 ~ 2) to act as communication partners and placed them outside of testing area.
3. The communication partners run test program “MFGTEST” to enable EUT under transmission/receiving condition continuously via UTP cables and wireless transmission.

Below 1GHz Test Data

4.2.7 TEST RESULTS

EUT TEST CONDITION		MEASUREMENT DETAIL	
CHANNEL	Channel 1	FREQUENCY RANGE	Below 1000MHz
MODULATION TYPE	802.11b	INPUT POWER (SYSTEM)	120Vac, 60 Hz
TRANSFER RATE	1Mbps	DETECTOR FUNCTION	Quasi-Peak
ENVIRONMENTAL CONDITIONS	24deg. C, 58%RH, 955hPa	TESTED BY	Sky Liao

ANTENNA POLARITY & TEST DISTANCE: HORIZONTAL AT 3 M

No.	Freq. (MHz)	Emission Level (dBuV/m)	Limit (dBuV/m)	Margin (dB)	Antenna Height (m)	Table Angle (Degree)	Raw Value (dBuV)	Correction Factor (dB/m)
1	299.98	37.57 QP	46.00	-8.43	2.98 H	128	20.74	16.83
2	375.01	35.01 QP	46.00	-10.99	2.87 H	147	16.81	18.20
3	399.98	37.44 QP	46.00	-8.56	2.50 H	23	18.42	19.02
4	500.01	39.60 QP	46.00	-6.40	2.43 H	11	17.84	21.76
5	600.01	40.11 QP	46.00	-5.89	2.00 H	179	15.63	24.48
6	625.01	40.17 QP	46.00	-5.83	2.11 H	39	15.41	24.76
7	792.01	44.39 QP	46.00	-1.61	1.14 H	258	16.86	27.53

ANTENNA POLARITY & TEST DISTANCE: VERTICAL AT 3 M

No.	Freq. (MHz)	Emission Level (dBuV/m)	Limit (dBuV/m)	Margin (dB)	Antenna Height (m)	Table Angle (Degree)	Raw Value (dBuV)	Correction Factor (dB/m)
1	125.00	41.98 QP	43.50	-1.52	1.00 V	299	29.76	12.22
2	225.01	44.79 QP	46.00	-1.21	1.00 V	247	32.10	12.69
3	300.01	37.13 QP	46.00	-8.87	1.00 V	22	20.30	16.83
4	375.02	39.13 QP	46.00	-6.87	1.00 V	123	20.93	18.20
5	399.98	37.83 QP	46.00	-8.17	1.69 V	45	18.81	19.02
6	499.99	39.48 QP	46.00	-6.52	1.88 V	199	17.72	21.76
7	599.98	35.77 QP	46.00	-10.23	2.01 V	137	11.29	24.48
8	625.37	35.20 QP	46.00	-10.80	2.21 V	179	10.44	24.76
9	750.01	42.36 QP	46.00	-3.64	2.98 V	221	15.01	27.35

- REMARKS:**
1. Emission level (dBuV/m) = Raw Value (dBuV) + Correction Factor (dB/m).
 2. Correction Factor (dB/m) = Antenna Factor (dB/m) + Cable Factor (dB).
 3. The other emission levels were very low against the limit.
 4. Margin value = Emission level – Limit value.

Above 1GHz Test Data

4.2.8 TEST RESULTS

802.11b DSSS MODULATION:

EUT TEST CONDITION		MEASUREMENT DETAIL	
CHANNEL	Channel 1	FREQUENCY RANGE	1 ~ 25GHz
MODULATION TYPE	DBPSK	INPUT POWER (SYSTEM)	120Vac, 60 Hz
TRANSFER RATE	1Mbps	DETECTOR FUNCTION	Peak(PK) Average (AV)
ENVIRONMENTAL CONDITIONS	22deg. C, 68%RH, 955hPa	TESTED BY	Wen Yu

ANTENNA POLARITY & TEST DISTANCE: HORIZONTAL AT 3 M

No.	Freq. (MHz)	Emission Level (dBuV/m)	Limit (dBuV/m)	Margin (dB)	Antenna Height (m)	Table Angle (Degree)	Raw Value (dBuV)	Correction Factor (dB/m)
1	2387.60	57.73 PK	74.00	-16.27	2.18 H	145	27.35	30.38
2	2387.60	47.71 AV	54.00	-6.29	2.18 H	145	17.33	30.38
3	*2412.00	99.73 PK			2.06 H	146	69.24	30.49
4	*2412.00	96.00 AV			2.06 H	146	65.51	30.49
5	4824.00	52.04 PK	74.00	-21.96	1.98 H	10	16.35	35.69
6	4824.00	47.63 AV	54.00	-6.37	1.98 H	10	11.94	35.69
7	7236.00	53.64 PK	74.00	-20.36	1.55 H	19	11.40	42.24
8	7236.00	41.31 AV	54.00	-12.69	1.55 H	19	-0.93	42.24
9	14472.00	60.15 PK	74.00	-13.85	1.63 H	255	10.92	49.23
10	14472.00	48.70 AV	54.00	-5.30	1.63 H	255	-0.53	49.23

ANTENNA POLARITY & TEST DISTANCE: VERTICAL AT 3 M

No.	Freq. (MHz)	Emission Level (dBuV/m)	Limit (dBuV/m)	Margin (dB)	Antenna Height (m)	Table Angle (Degree)	Raw Value (dBuV)	Correction Factor (dB/m)
1	2389.36	64.42 PK	74.00	-9.58	1.14 V	348	34.03	30.39
2	2389.36	52.40 AV	54.00	-1.60	1.14 V	348	22.01	30.39
3	*2412.00	111.40 PK			1.09 V	92	80.91	30.49
4	*2412.00	106.80 AV			1.09 V	92	76.31	30.49
5	4824.00	52.70 PK	74.00	-21.30	1.45 V	182	17.01	35.69
6	4824.00	50.50 AV	54.00	-3.50	1.45 V	182	14.81	35.69
7	7236.00	52.90 PK	74.00	-21.10	1.64 V	202	10.66	42.24
8	7236.00	42.80 AV	54.00	-11.20	1.64 V	202	0.56	42.24
9	14472.00	60.20 PK	74.00	-13.80	1.29 V	139	10.97	49.23
10	14472.00	49.10 AV	54.00	-4.90	1.29 V	139	-0.13	49.23

- REMARKS:**
1. Emission level (dBuV/m) = Raw Value (dBuV) + Correction Factor (dB/m).
 2. Correction Factor (dB/m) = Antenna Factor (dB/m) + Cable Factor (dB).
 3. The other emission levels were very low against the limit.
 4. Margin value = Emission level – Limit value.
 5. The limit value is defined as per 15.247.
 6. " * ": Fundamental frequency.

EUT TEST CONDITION		MEASUREMENT DETAIL	
CHANNEL	Channel 6	FREQUENCY RANGE	1 ~ 25GHz
MODULATION TYPE	DBPSK	INPUT POWER (SYSTEM)	120Vac, 60 Hz
TRANSFER RATE	1Mbps	DETECTOR FUNCTION	Peak(PK) Average (AV)
ENVIRONMENTAL CONDITIONS	22deg. C, 68%RH, 955hPa	TESTED BY	Wen Yu

ANTENNA POLARITY & TEST DISTANCE: HORIZONTAL AT 3 M

No.	Freq. (MHz)	Emission Level (dBuV/m)	Limit (dBuV/m)	Margin (dB)	Antenna Height (m)	Table Angle (Degree)	Raw Value (dBuV)	Correction Factor (dB/m)
1	*2437.00	102.01 PK			1.63 H	306	71.40	30.61
2	*2437.00	98.23 AV			1.63 H	306	67.62	30.61
3	4874.00	52.13 PK	74.00	-21.87	1.41 H	15	16.33	35.80
4	4874.00	47.23 AV	54.00	-6.77	1.41 H	15	11.43	35.80
5	7311.00	55.26 PK	74.00	-18.74	1.50 H	23	12.74	42.52
6	7311.00	42.88 AV	54.00	-11.12	1.50 H	23	0.36	42.52

ANTENNA POLARITY & TEST DISTANCE: VERTICAL AT 3 M

No.	Freq. (MHz)	Emission Level (dBuV/m)	Limit (dBuV/m)	Margin (dB)	Antenna Height (m)	Table Angle (Degree)	Raw Value (dBuV)	Correction Factor (dB/m)
1	*2437.00	113.20 PK			1.05 V	17	82.59	30.61
2	*2437.00	108.40 AV			1.05 V	17	77.79	30.61
3	4874.00	54.81 PK	74.00	-19.19	1.39 V	187	19.01	35.80
4	4874.00	52.80 AV	54.00	-1.20	1.39 V	187	17.00	35.80
5	7311.00	55.13 PK	74.00	-18.87	1.57 V	152	12.61	42.52
6	7311.00	47.22 AV	54.00	-6.78	1.57 V	152	4.70	42.52

- REMARKS:**
1. Emission level (dBuV/m) = Raw Value (dBuV) + Correction Factor (dB/m).
 2. Correction Factor (dB/m) = Antenna Factor (dB/m) + Cable Factor (dB).
 3. The other emission levels were very low against the limit.
 4. Margin value = Emission level – Limit value.
 5. The limit value is defined as per 15.247.
 6. “ * “: Fundamental frequency.

EUT TEST CONDITION		MEASUREMENT DETAIL	
CHANNEL	Channel 11	FREQUENCY RANGE	1 ~ 25GHz
MODULATION TYPE	DBPSK	INPUT POWER (SYSTEM)	120Vac, 60 Hz
TRANSFER RATE	1Mbps	DETECTOR FUNCTION	Peak(PK) Average (AV)
ENVIRONMENTAL CONDITIONS	22deg. C, 68%RH, 955hPa	TESTED BY	Wen Yu

ANTENNA POLARITY & TEST DISTANCE: HORIZONTAL AT 3 M

No.	Freq. (MHz)	Emission Level (dBuV/m)	Limit (dBuV/m)	Margin (dB)	Antenna Height (m)	Table Angle (Degree)	Raw Value (dBuV)	Correction Factor (dB/m)
1	*2462.00	98.76 PK			1.63 H	307	68.04	30.72
2	*2462.00	94.23 AV			1.63 H	307	63.51	30.72
3	2486.30	57.03 PK	74.00	-16.97	1.01 H	17	26.20	30.83
4	2486.30	45.58 AV	54.00	-8.42	1.01 H	17	14.75	30.83
5	4924.00	51.68 PK	74.00	-22.32	1.52 H	17	15.78	35.90
6	4924.00	47.12 AV	54.00	-6.88	1.52 H	17	11.22	35.90
7	7386.00	53.75 PK	74.00	-20.25	1.58 H	21	10.95	42.80
8	7386.00	41.96 AV	54.00	-12.04	1.58 H	21	-0.84	42.80

ANTENNA POLARITY & TEST DISTANCE: VERTICAL AT 3 M

No.	Freq. (MHz)	Emission Level (dBuV/m)	Limit (dBuV/m)	Margin (dB)	Antenna Height (m)	Table Angle (Degree)	Raw Value (dBuV)	Correction Factor (dB/m)
1	*2462.00	112.30 PK			1.00 V	91	81.58	30.72
2	*2462.00	108.00 AV			1.00 V	91	77.28	30.72
3	2486.30	61.31 PK	74.00	-12.69	1.00 V	90	30.48	30.83
4	2486.30	53.49 AV	54.00	-0.51	1.00 V	90	22.66	30.83
5	4924.00	53.30 PK	74.00	-20.70	1.00 V	70	17.40	35.90
6	4924.00	49.50 AV	54.00	-4.50	1.00 V	70	13.60	35.90
7	7386.00	56.70 PK	74.00	-17.30	1.36 V	63	13.90	42.80
8	7386.00	46.70 AV	54.00	-7.30	1.36 V	63	3.90	42.80

- REMARKS:**
1. Emission level (dBuV/m) = Raw Value (dBuV) + Correction Factor (dB/m).
 2. Correction Factor (dB/m) = Antenna Factor (dB/m) + Cable Factor (dB).
 3. The other emission levels were very low against the limit.
 4. Margin value = Emission level – Limit value.
 5. The limit value is defined as per 15.247.
 6. “ * “: Fundamental frequency.

RESTRICTED BANDEDGE (802.11b MODE, CH1, HORIZONTAL)

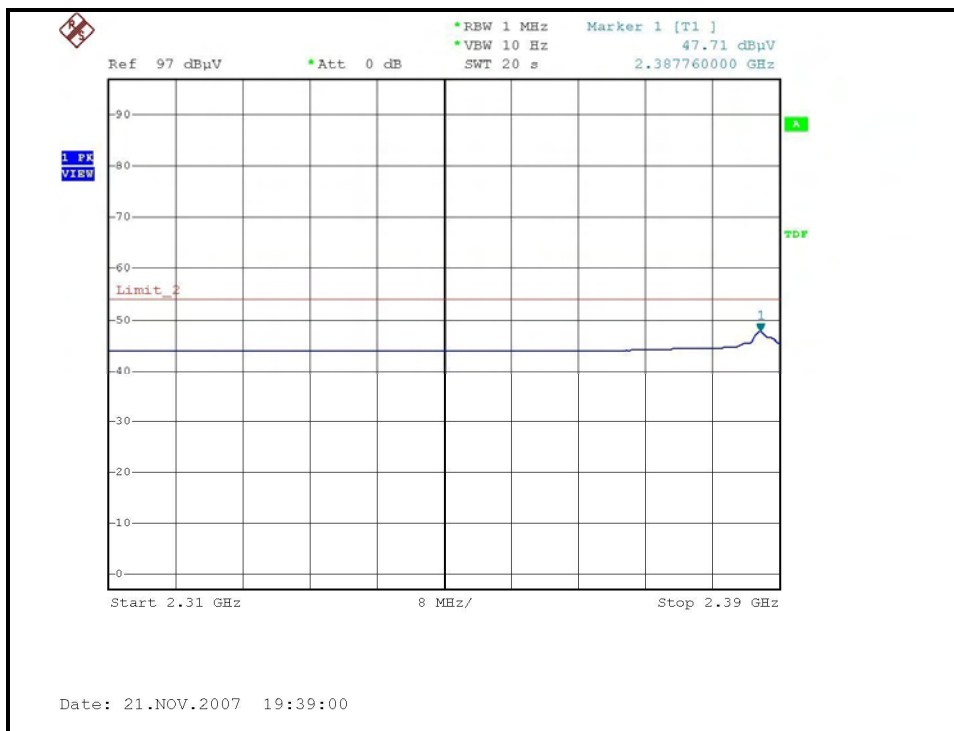
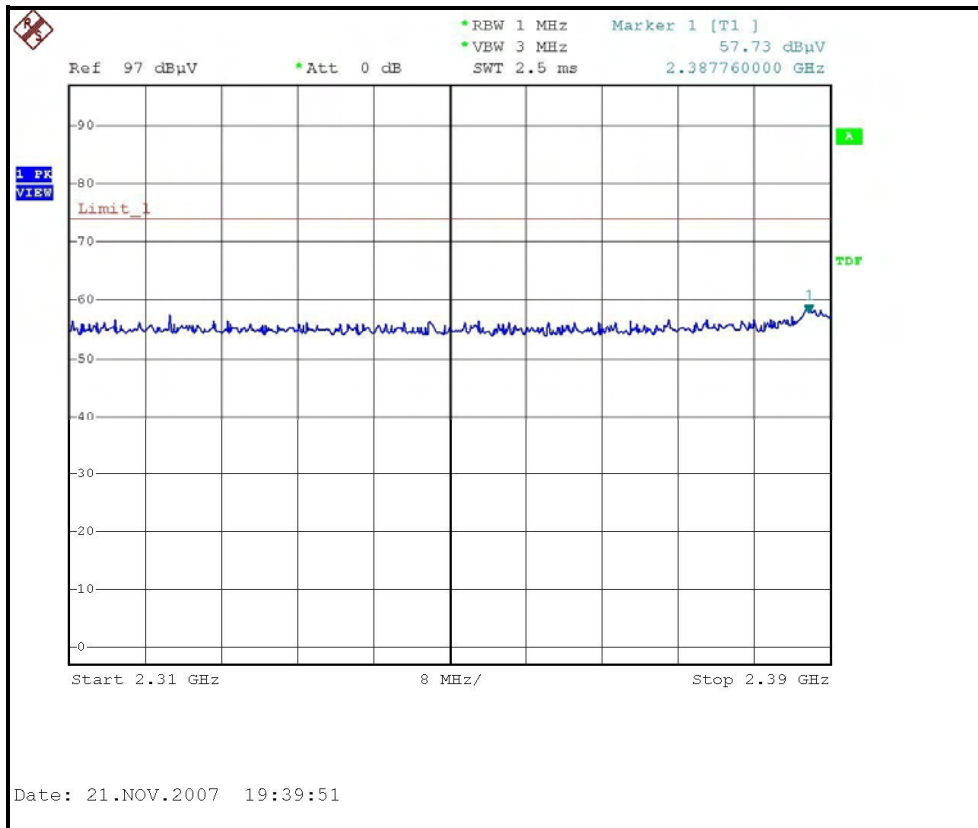

RESTRICTED BANDEDGE (802.11b MODE, CH1, VERTICAL)

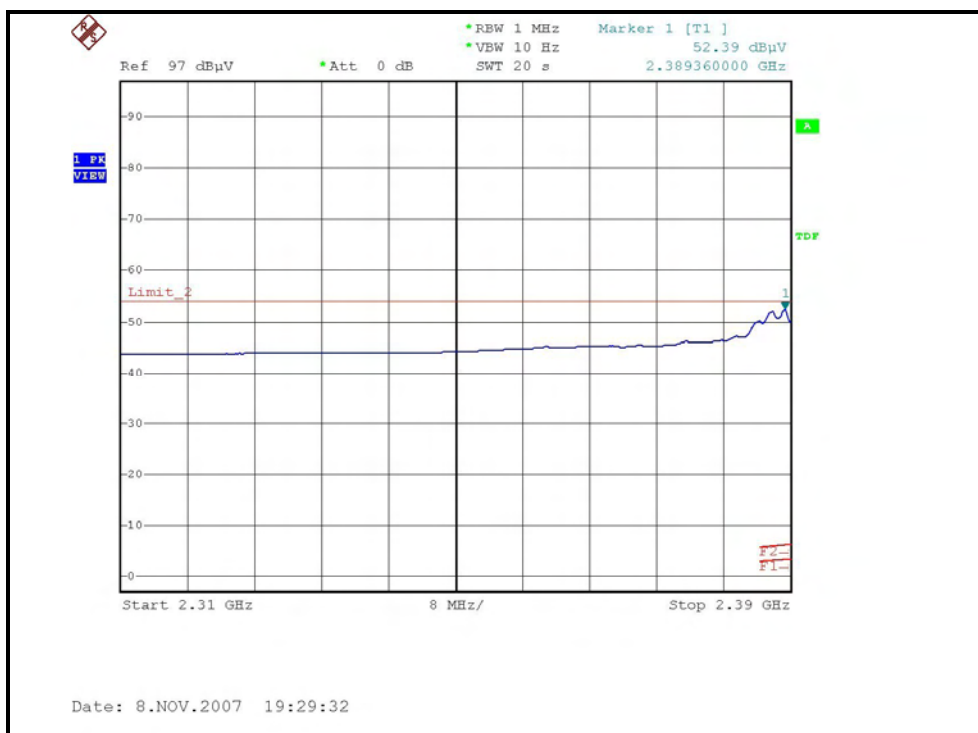
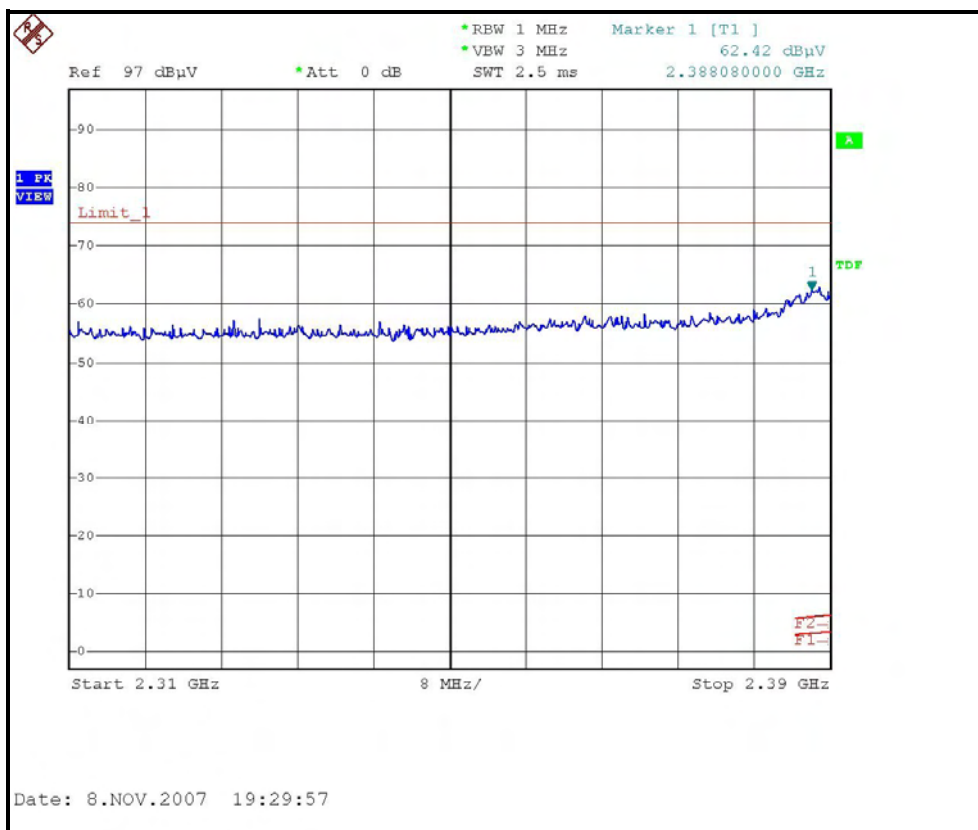

RESTRICTED BANDEDGE (802.11b MODE,CH11, HORIZONTAL)

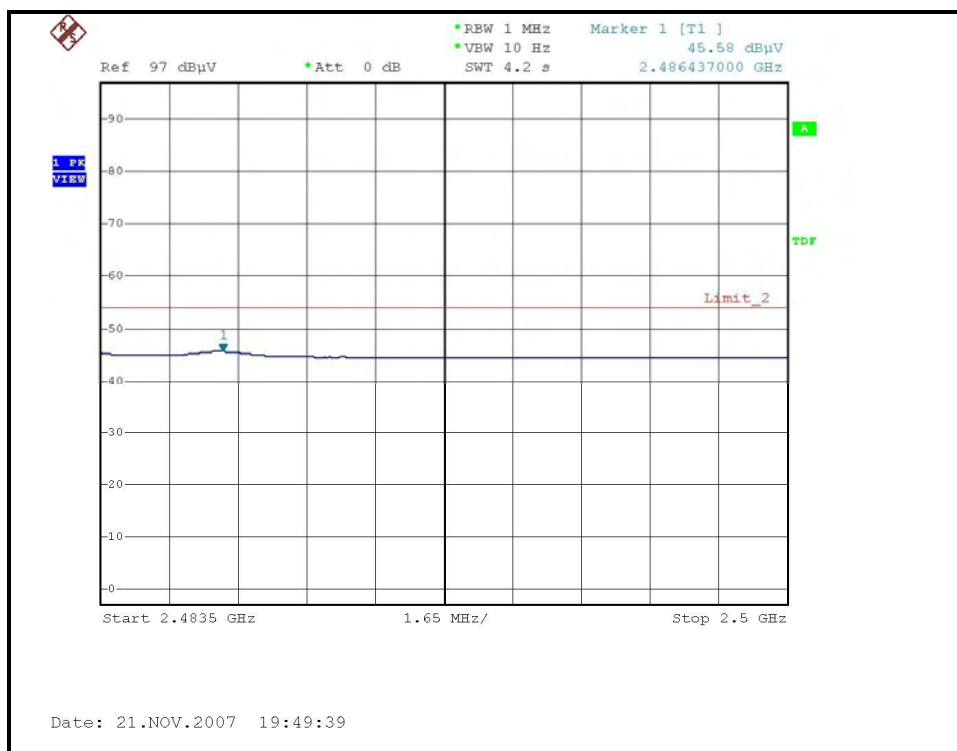
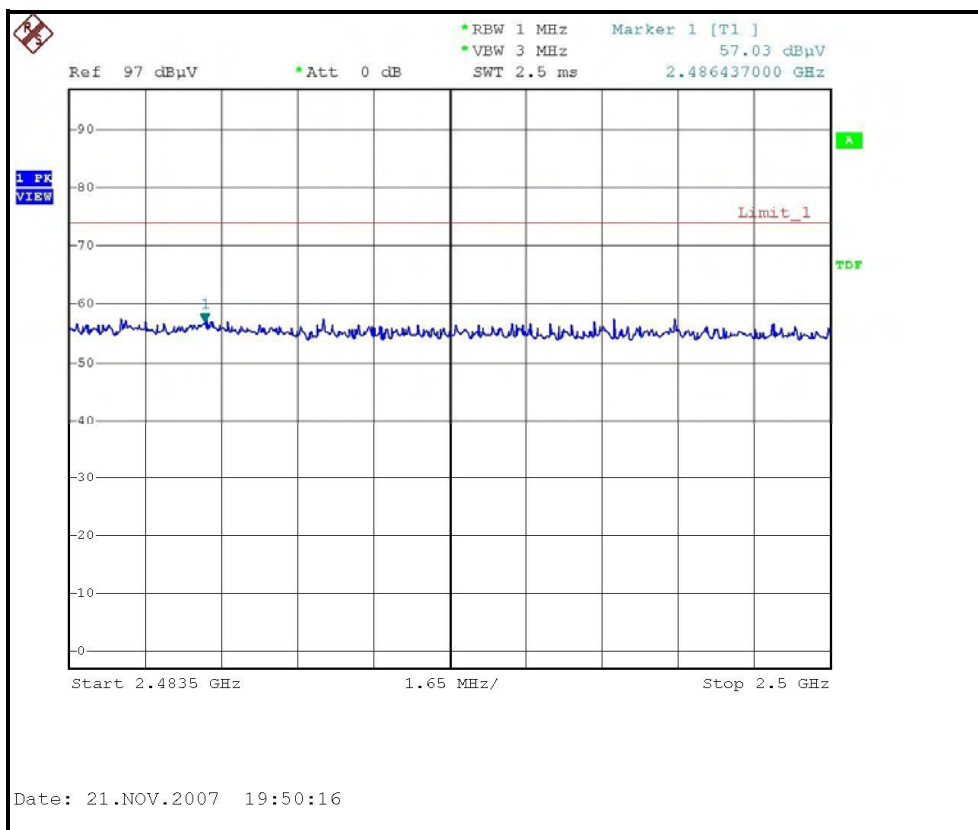

RESTRICTED BANDEDGE (802.11b MODE,CH11, VERTICAL)

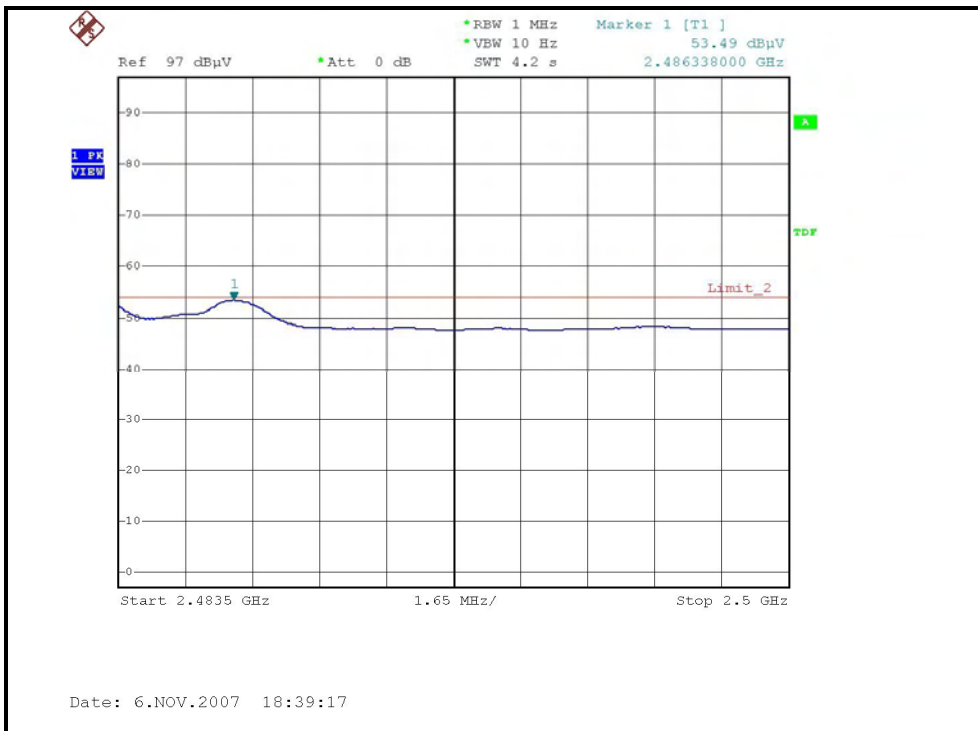
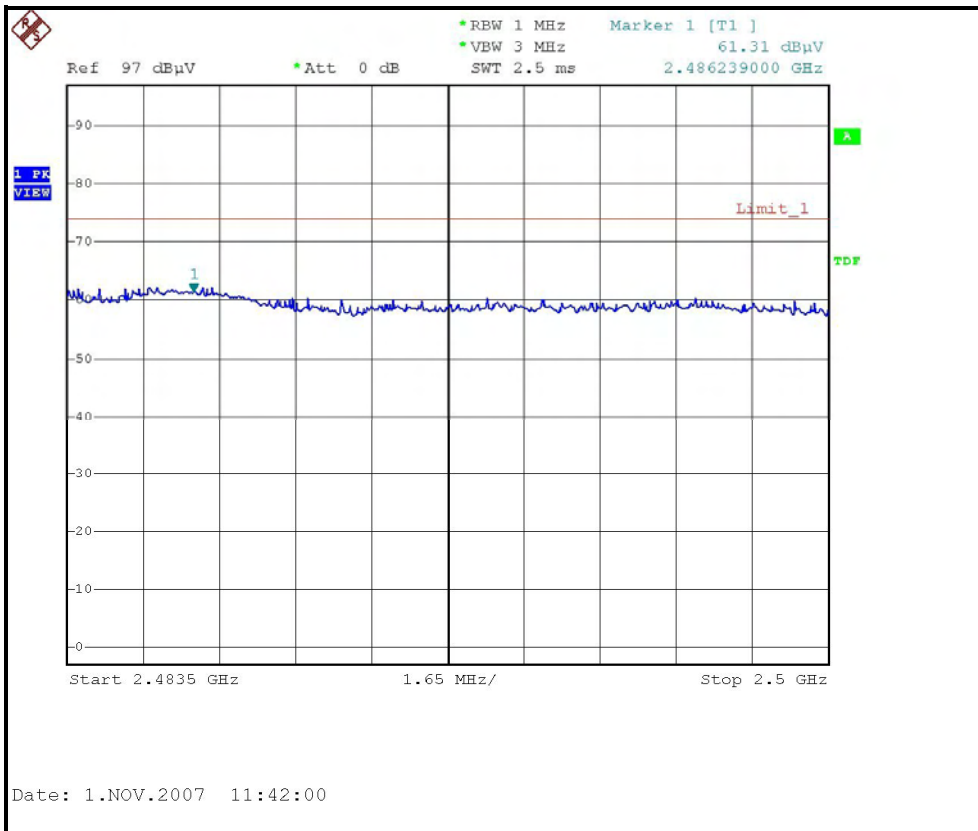

802.11g OFDM MODULATION:

EUT TEST CONDITION		MEASUREMENT DETAIL	
CHANNEL	Channel 1	FREQUENCY RANGE	1 ~ 25GHz
MODULATION TYPE	BPSK	INPUT POWER (SYSTEM)	120Vac, 60 Hz
TRANSFER RATE	6Mbps	DETECTOR FUNCTION	Peak(PK) Average (AV)
ENVIRONMENTAL CONDITIONS	22deg. C, 68%RH, 955hPa	TESTED BY	Wen Yu

ANTENNA POLARITY & TEST DISTANCE: HORIZONTAL AT 3 M

No.	Freq. (MHz)	Emission Level (dBuV/m)	Limit (dBuV/m)	Margin (dB)	Antenna Height (m)	Table Angle (Degree)	Raw Value (dBuV)	Correction Factor (dB/m)
1	2390.00	56.93 PK	74.00	-17.07	2.04 H	317	26.53	30.40
2	2390.00	45.86 AV	54.00	-8.14	2.04 H	317	15.46	30.40
3	*2412.00	104.03 PK			1.62 H	306	73.54	30.49
4	*2412.00	93.13 AV			1.62 H	306	62.64	30.49
5	4824.00	50.93 PK	74.00	-23.07	1.42 H	0	15.24	35.69
6	4824.00	44.87 AV	54.00	-9.13	1.42 H	0	9.18	35.69
7	7236.00	59.12 PK	74.00	-14.88	1.66 H	331	16.88	42.24
8	7236.00	42.61 AV	54.00	-11.39	1.66 H	331	0.37	42.24

ANTENNA POLARITY & TEST DISTANCE: VERTICAL AT 3 M

No.	Freq. (MHz)	Emission Level (dBuV/m)	Limit (dBuV/m)	Margin (dB)	Antenna Height (m)	Table Angle (Degree)	Raw Value (dBuV)	Correction Factor (dB/m)
1	2389.04	71.94 PK	74.00	-2.06	1.11 V	168	41.55	30.39
2	2389.04	52.91 AV	54.00	-1.09	1.11 V	168	22.52	30.39
3	*2412.00	114.90 PK			1.07 V	279	84.41	30.49
4	*2412.00	104.30 AV			1.07 V	279	73.81	30.49
5	4824.00	54.30 PK	74.00	-19.70	1.56 V	234	18.61	35.69
6	4824.00	47.70 AV	54.00	-6.30	1.56 V	234	12.01	35.69
7	7236.00	59.67 PK	74.00	-14.33	1.50 V	279	17.43	42.24
8	7236.00	48.26 AV	54.00	-5.74	1.50 V	279	6.02	42.24

- REMARKS:**
1. Emission level (dBuV/m) = Raw Value (dBuV) + Correction Factor (dB/m).
 2. Correction Factor (dB/m) = Antenna Factor (dB/m) + Cable Factor (dB).
 3. The other emission levels were very low against the limit.
 4. Margin value = Emission level – Limit value.
 5. The limit value is defined as per 15.247.
 6. “ * “: Fundamental frequency.

EUT TEST CONDITION		MEASUREMENT DETAIL	
CHANNEL	Channel 6	FREQUENCY RANGE	1 ~ 25GHz
MODULATION TYPE	BPSK	INPUT POWER (SYSTEM)	120Vac, 60 Hz
TRANSFER RATE	6Mbps	DETECTOR FUNCTION	Peak(PK) Average (AV)
ENVIRONMENTAL CONDITIONS	22deg. C, 68%RH, 955hPa	TESTED BY	Wen Yu

ANTENNA POLARITY & TEST DISTANCE: HORIZONTAL AT 3 M								
No.	Freq. (MHz)	Emission Level (dBuV/m)	Limit (dBuV/m)	Margin (dB)	Antenna Height (m)	Table Angle (Degree)	Raw Value (dBuV)	Correction Factor (dB/m)
1	2390.00	56.75 PK	74.00	-17.25	1.95 H	316	26.35	30.40
2	2390.00	44.89 AV	54.00	-9.11	1.95 H	316	14.49	30.40
3	*2437.00	107.22 PK			1.84 H	317	76.61	30.61
4	*2437.00	96.65 AV			1.84 H	317	66.04	30.61
5	2483.50	56.20 PK	74.00	-17.80	1.73 H	294	25.38	30.82
6	2483.50	45.07 AV	54.00	-8.93	1.73 H	294	14.25	30.82
7	4874.00	51.09 PK	74.00	-22.91	1.41 H	1	15.29	35.80
8	4874.00	45.00 AV	54.00	-9.00	1.41 H	1	9.20	35.80
9	7311.00	59.31 PK	74.00	-14.69	1.65 H	328	16.79	42.52
10	7311.00	42.80 AV	54.00	-11.20	1.65 H	328	0.28	42.52

ANTENNA POLARITY & TEST DISTANCE: VERTICAL AT 3 M								
No.	Freq. (MHz)	Emission Level (dBuV/m)	Limit (dBuV/m)	Margin (dB)	Antenna Height (m)	Table Angle (Degree)	Raw Value (dBuV)	Correction Factor (dB/m)
1	2389.04	71.70 PK	74.00	-2.30	1.10 V	167	41.31	30.39
2	2389.04	52.60 AV	54.00	-1.40	1.10 V	167	22.21	30.39
3	*2437.00	120.40 PK			1.06 V	167	89.79	30.61
4	*2437.00	109.10 AV			1.06 V	167	78.49	30.61
5	2484.78	69.94 PK	74.00	-4.06	1.31 V	195	39.12	30.82
6	2484.78	52.80 AV	54.00	-1.20	1.31 V	195	21.98	30.82
7	4874.00	53.20 PK	74.00	-20.80	1.71 V	128	17.40	35.80
8	4874.00	47.90 AV	54.00	-6.10	1.71 V	128	12.10	35.80
9	7311.00	59.90 PK	74.00	-14.10	1.55 V	272	17.38	42.52
10	7311.00	48.30 AV	54.00	-5.70	1.55 V	272	5.78	42.52

- REMARKS:**
1. Emission level (dBuV/m) = Raw Value (dBuV) + Correction Factor (dB/m).
 2. Correction Factor (dB/m) = Antenna Factor (dB/m) + Cable Factor (dB).
 3. The other emission levels were very low against the limit.
 4. Margin value = Emission level – Limit value.
 5. The limit value is defined as per 15.247.
 6. “ * “: Fundamental frequency.

EUT TEST CONDITION		MEASUREMENT DETAIL	
CHANNEL	Channel 11	FREQUENCY RANGE	1 ~ 25GHz
MODULATION TYPE	BPSK	INPUT POWER (SYSTEM)	120Vac, 60 Hz
TRANSFER RATE	6Mbps	DETECTOR FUNCTION	Peak(PK) Average (AV)
ENVIRONMENTAL CONDITIONS	22deg. C, 68%RH, 955hPa	TESTED BY	Wen Yu

ANTENNA POLARITY & TEST DISTANCE: HORIZONTAL AT 3 M

No.	Freq. (MHz)	Emission Level (dBuV/m)	Limit (dBuV/m)	Margin (dB)	Antenna Height (m)	Table Angle (Degree)	Raw Value (dBuV)	Correction Factor (dB/m)
1	*2462.00	100.93 PK			1.75 H	306	70.21	30.72
2	*2462.00	90.53 AV			1.75 H	306	59.81	30.72
3	2483.50	60.18 PK	74.00	-13.82	2.13 H	304	29.36	30.82
4	2483.50	45.29 AV	54.00	-8.71	2.13 H	304	14.47	30.82
5	4924.00	51.15 PK	74.00	-22.85	1.42 H	5	15.25	35.90
6	4924.00	45.13 AV	54.00	-8.87	1.42 H	5	9.23	35.90
7	7386.00	59.12 PK	74.00	-14.88	1.60 H	315	16.32	42.80
8	7386.00	42.62 AV	54.00	-11.38	1.60 H	315	-0.18	42.80

ANTENNA POLARITY & TEST DISTANCE: VERTICAL AT 3 M

No.	Freq. (MHz)	Emission Level (dBuV/m)	Limit (dBuV/m)	Margin (dB)	Antenna Height (m)	Table Angle (Degree)	Raw Value (dBuV)	Correction Factor (dB/m)
1	*2462.00	112.68 PK			1.08 V	171	81.96	30.72
2	*2462.00	102.32 AV			1.08 V	171	71.60	30.72
3	2483.50	69.80 PK	74.00	-4.20	1.02 V	170	38.98	30.82
4	2483.50	53.11 AV	54.00	-0.89	1.02 V	170	22.29	30.82
5	4924.00	53.79 PK	74.00	-20.21	1.69 V	131	17.89	35.90
6	4924.00	47.80 AV	54.00	-6.20	1.69 V	131	11.90	35.90
7	7386.00	60.32 PK	74.00	-13.68	1.52 V	278	17.52	42.80
8	7386.00	48.81 AV	54.00	-5.19	1.52 V	278	6.01	42.80

- REMARKS:**
1. Emission level (dBuV/m) = Raw Value (dBuV) + Correction Factor (dB/m).
 2. Correction Factor (dB/m) = Antenna Factor (dB/m) + Cable Factor (dB).
 3. The other emission levels were very low against the limit.
 4. Margin value = Emission level – Limit value.
 5. The limit value is defined as per 15.247.
 6. " * ": Fundamental frequency.

RESTRICTED BANDEDGE (802.11g MODE, CH1, HORIZONTAL)

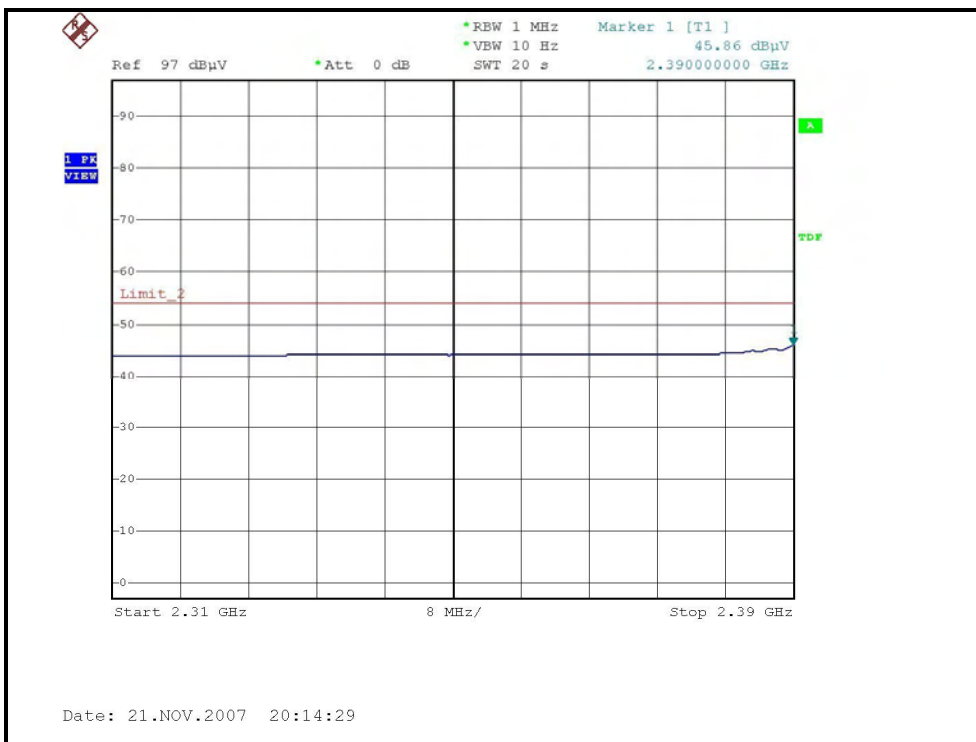
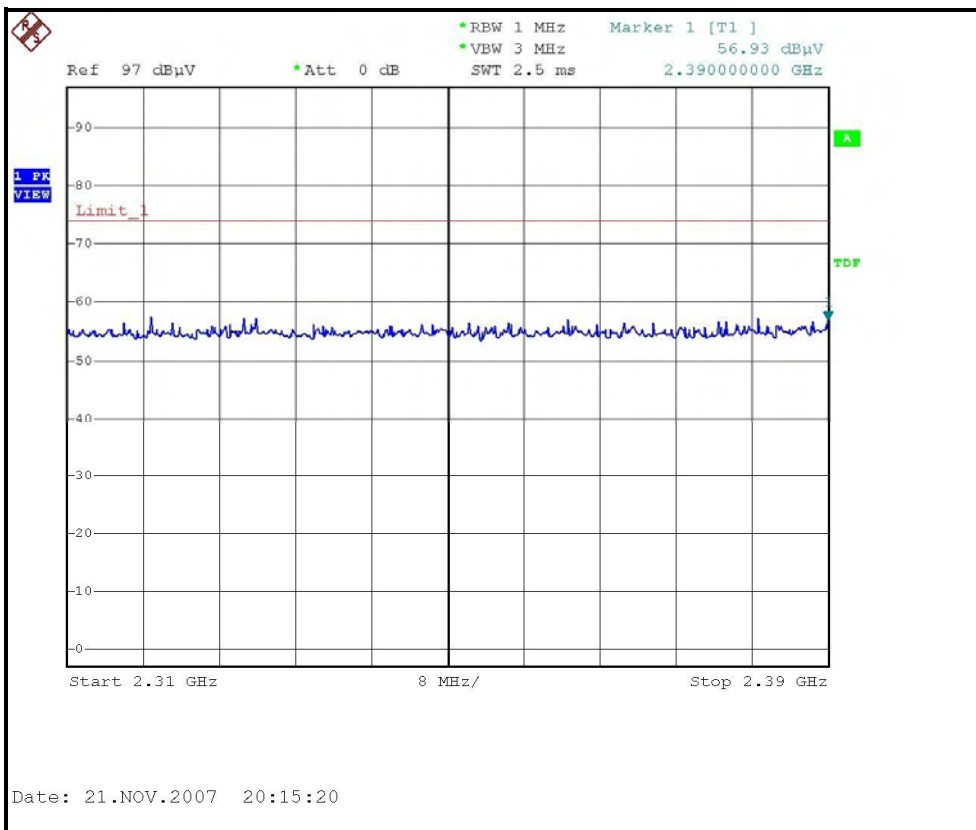

RESTRICTED BANDEDGE (802.11g MODE,CH1, VERTICAL)

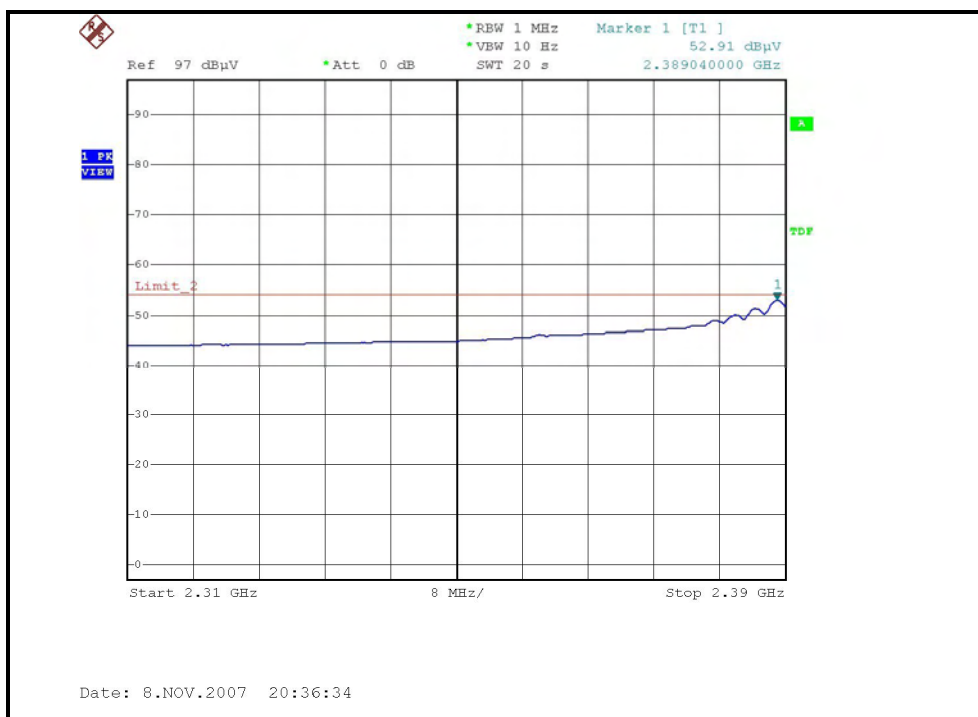
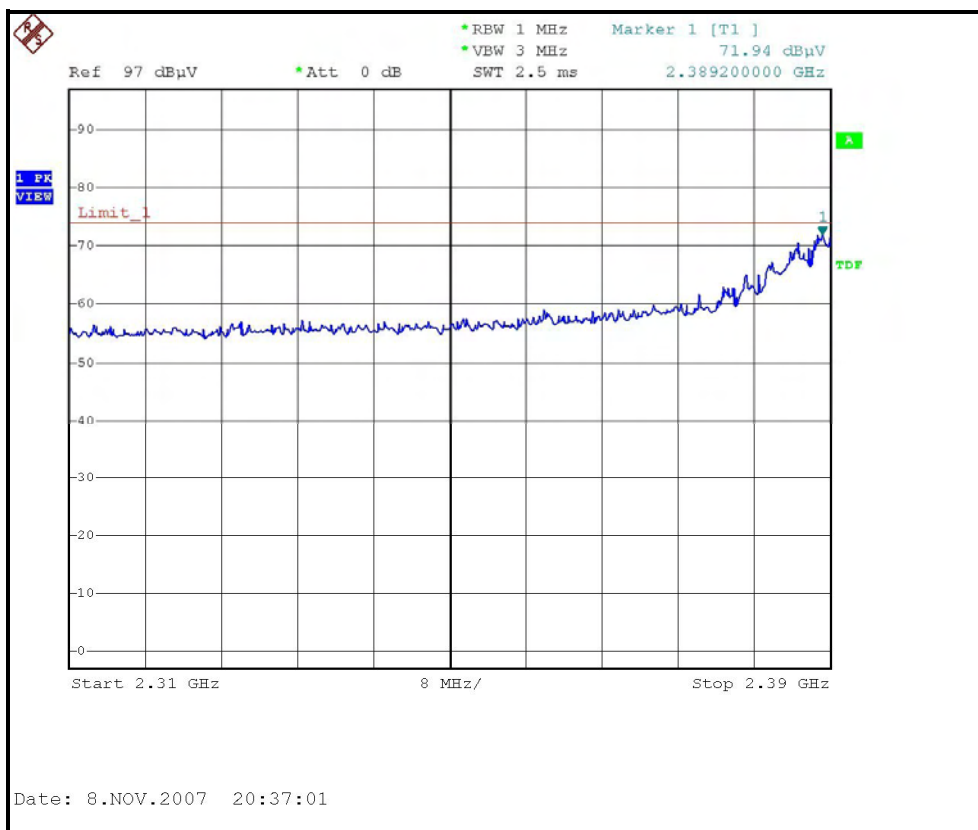

RESTRICTED BANDEDGE (802.11g MODE,CH11, HORIZONTAL)

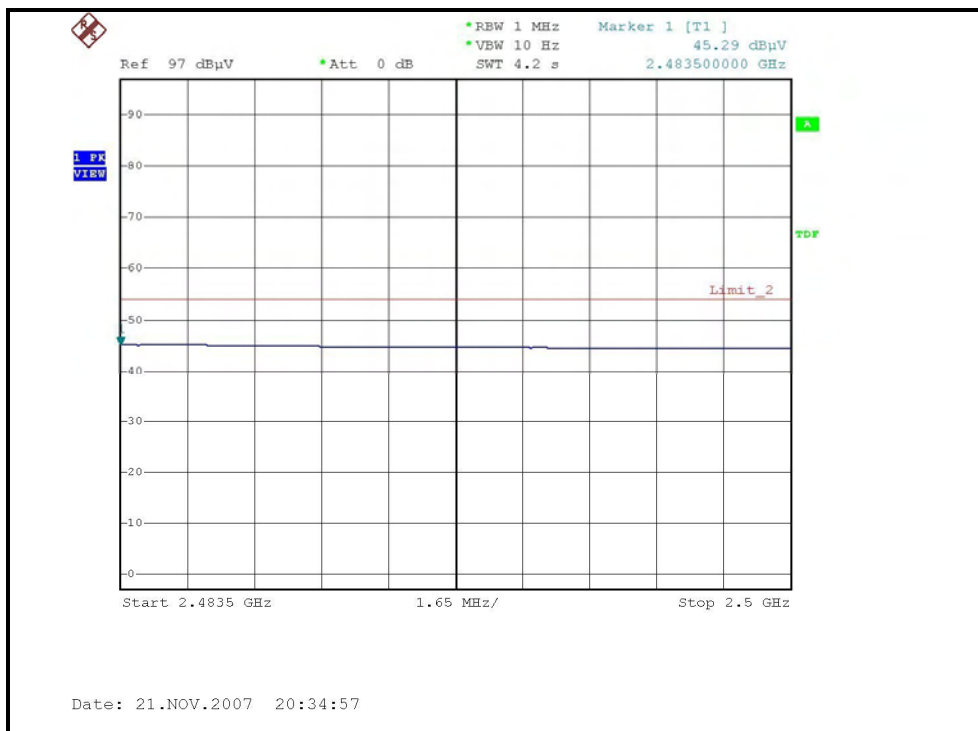
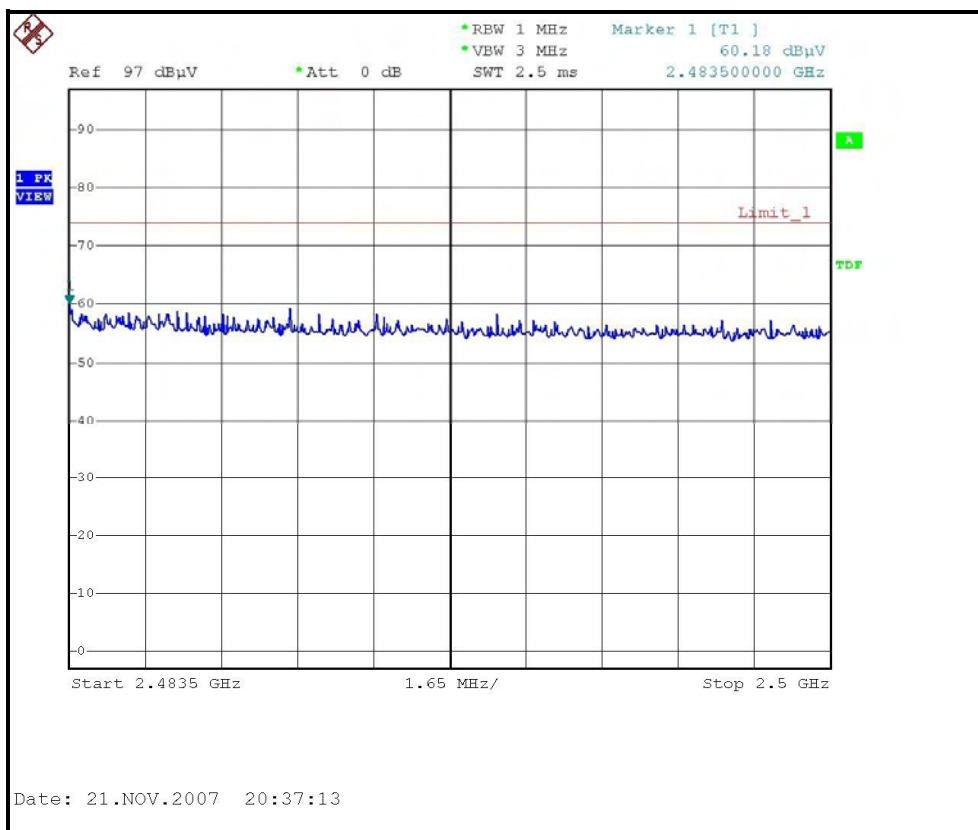

RESTRICTED BANDEDGE (802.11g MODE, CH11, VERTICAL)

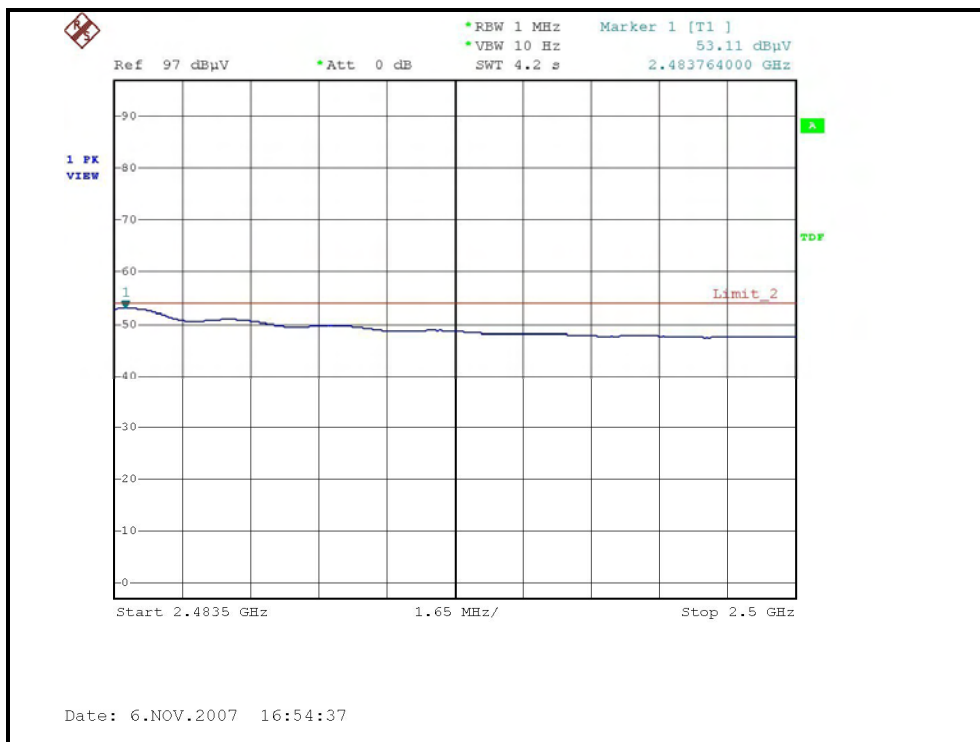
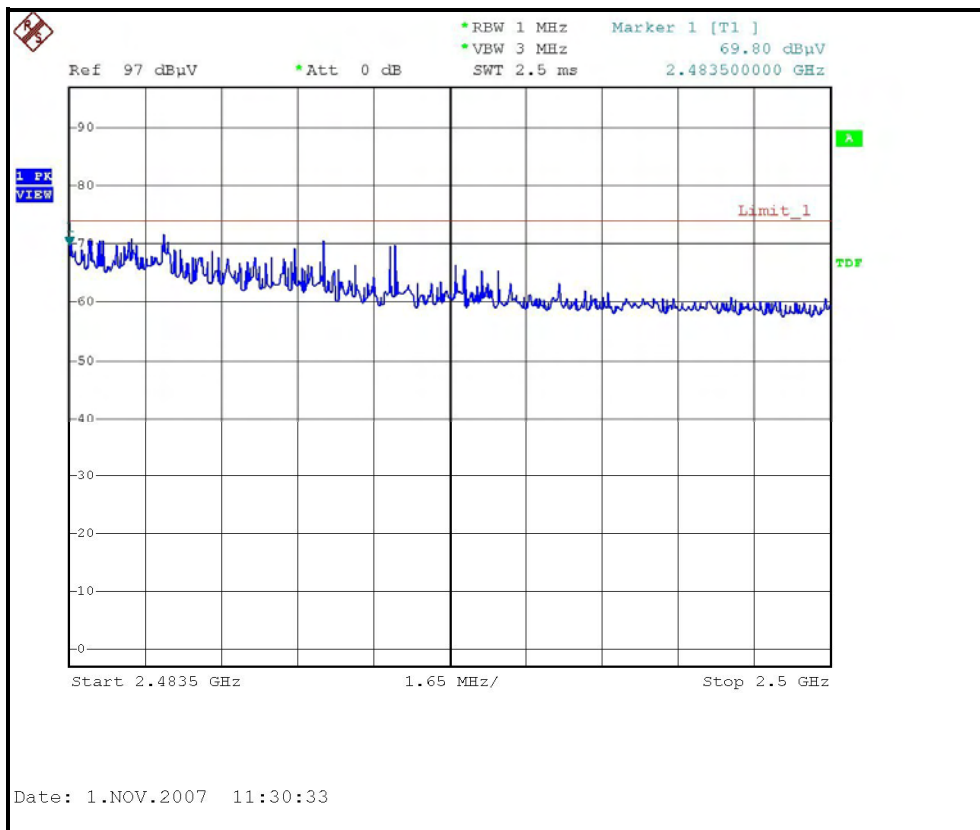



DRAFT 802.11n (20MHz) OFDM MODULATION:

EUT TEST CONDITION		MEASUREMENT DETAIL	
CHANNEL	Channel 1	FREQUENCY RANGE	1 ~ 25GHz
MODULATION TYPE	BPSK	INPUT POWER (SYSTEM)	120Vac, 60 Hz
TRANSFER RATE	6.5Mbps	DETECTOR FUNCTION	Peak(PK) Average (AV)
ENVIRONMENTAL CONDITIONS	22deg. C, 68%RH, 955hPa	TESTED BY	Wen Yu

ANTENNA POLARITY & TEST DISTANCE: HORIZONTAL AT 3 M

No.	Freq. (MHz)	Emission Level (dBuV/m)	Limit (dBuV/m)	Margin (dB)	Antenna Height (m)	Table Angle (Degree)	Raw Value (dBuV)	Correction Factor (dB/m)
1	2390.00	60.27 PK	74.00	-13.73	1.62 H	7	29.87	30.40
2	2390.00	45.05 AV	54.00	-8.95	1.62 H	7	14.65	30.40
3	*2412.00	102.60 PK			1.61 H	302	72.11	30.49
4	*2412.00	91.21 AV			1.61 H	302	60.72	30.49
5	4824.00	50.02 PK	74.00	-23.98	1.50 H	336	14.33	35.69
6	4824.00	42.86 AV	54.00	-11.14	1.50 H	336	7.17	35.69
7	7236.00	61.65 PK	74.00	-12.35	1.66 H	325	19.41	42.24
8	7236.00	42.62 AV	54.00	-11.38	1.66 H	325	0.38	42.24

ANTENNA POLARITY & TEST DISTANCE: VERTICAL AT 3 M

No.	Freq. (MHz)	Emission Level (dBuV/m)	Limit (dBuV/m)	Margin (dB)	Antenna Height (m)	Table Angle (Degree)	Raw Value (dBuV)	Correction Factor (dB/m)
1	2390.00	71.90 PK	74.00	-2.10	1.10 V	167	41.51	30.40
2	2390.00	53.20 AV	54.00	-0.80	1.10 V	167	22.80	30.40
3	*2412.00	115.70 PK			1.07 V	167	85.21	30.49
4	*2412.00	102.60 AV			1.07 V	167	72.11	30.49
5	4824.00	53.70 PK	74.00	-20.30	1.77 V	118	18.01	35.69
6	4824.00	48.00 AV	54.00	-6.00	1.77 V	118	12.31	35.69
7	7236.00	62.38 PK	74.00	-11.62	1.49 V	271	20.14	42.24
8	7236.00	46.33 AV	54.00	-7.67	1.49 V	271	4.09	42.24

- REMARKS:**
1. Emission level (dBuV/m) = Raw Value (dBuV) + Correction Factor (dB/m).
 2. Correction Factor (dB/m) = Antenna Factor (dB/m) + Cable Factor (dB).
 3. The other emission levels were very low against the limit.
 4. Margin value = Emission level – Limit value.
 5. The limit value is defined as per 15.247.
 6. “ * “: Fundamental frequency.

EUT TEST CONDITION		MEASUREMENT DETAIL	
CHANNEL	Channel 6	FREQUENCY RANGE	1 ~ 25GHz
MODULATION TYPE	BPSK	INPUT POWER (SYSTEM)	120Vac, 60 Hz
TRANSFER RATE	6.5Mbps	DETECTOR FUNCTION	Peak(PK) Average (AV)
ENVIRONMENTAL CONDITIONS	22deg. C, 68%RH, 955hPa	TESTED BY	Wen Yu

ANTENNA POLARITY & TEST DISTANCE: HORIZONTAL AT 3 M								
No.	Freq. (MHz)	Emission Level (dBuV/m)	Limit (dBuV/m)	Margin (dB)	Antenna Height (m)	Table Angle (Degree)	Raw Value (dBuV)	Correction Factor (dB/m)
1	2390.00	57.74 PK	74.00	-16.26	1.61 H	6	27.34	30.40
2	2390.00	45.00 AV	54.00	-9.00	1.61 H	6	14.60	30.40
3	*2437.00	108.23 PK			1.93 H	7	77.62	30.61
4	*2437.00	96.96 AV			1.93 H	7	66.35	30.61
5	2483.50	61.20 PK	74.00	-12.80	1.82 H	21	30.38	30.82
6	2483.50	46.13 AV	54.00	-7.87	1.82 H	21	15.31	30.82
7	4874.00	50.28 PK	74.00	-23.72	1.51 H	337	14.48	35.80
8	4874.00	43.12 AV	54.00	-10.88	1.51 H	337	7.32	35.80
9	7311.00	61.84 PK	74.00	-12.16	1.61 H	329	19.32	42.52
10	7311.00	42.89 AV	54.00	-11.11	1.61 H	329	0.37	42.52

ANTENNA POLARITY & TEST DISTANCE: VERTICAL AT 3 M								
No.	Freq. (MHz)	Emission Level (dBuV/m)	Limit (dBuV/m)	Margin (dB)	Antenna Height (m)	Table Angle (Degree)	Raw Value (dBuV)	Correction Factor (dB/m)
1	2390.00	67.90 PK	74.00	-6.10	1.11 V	167	37.51	30.40
2	2390.00	52.81 AV	54.00	-1.19	1.11 V	167	22.41	30.40
3	*2437.00	119.20 PK			1.05 V	279	88.59	30.61
4	*2437.00	106.60 AV			1.05 V	279	75.99	30.61
5	2483.50	68.70 PK	74.00	-5.30	1.31 V	195	37.88	30.82
6	2483.50	52.40 AV	54.00	-1.60	1.31 V	195	21.58	30.82
7	4874.00	52.00 PK	74.00	-22.00	1.42 V	29	16.20	35.80
8	4874.00	46.90 AV	54.00	-7.10	1.42 V	29	11.10	35.80
9	7311.00	62.11 PK	74.00	-11.89	1.48 V	276	19.59	42.52
10	7311.00	45.90 AV	54.00	-8.10	1.48 V	276	3.38	42.52

- REMARKS:**
1. Emission level (dBuV/m) = Raw Value (dBuV) + Correction Factor (dB/m).
 2. Correction Factor (dB/m) = Antenna Factor (dB/m) + Cable Factor (dB).
 3. The other emission levels were very low against the limit.
 4. Margin value = Emission level – Limit value.
 5. The limit value is defined as per 15.247.
 6. “ * “: Fundamental frequency.

EUT TEST CONDITION		MEASUREMENT DETAIL	
CHANNEL	Channel 11	FREQUENCY RANGE	1 ~ 25GHz
MODULATION TYPE	BPSK	INPUT POWER (SYSTEM)	120Vac, 60 Hz
TRANSFER RATE	6.5Mbps	DETECTOR FUNCTION	Peak(PK) Average (AV)
ENVIRONMENTAL CONDITIONS	22deg. C, 68%RH, 955hPa	TESTED BY	Wen Yu

ANTENNA POLARITY & TEST DISTANCE: HORIZONTAL AT 3 M

No.	Freq. (MHz)	Emission Level (dBuV/m)	Limit (dBuV/m)	Margin (dB)	Antenna Height (m)	Table Angle (Degree)	Raw Value (dBuV)	Correction Factor (dB/m)
1	*2462.00	102.05 PK			1.82 H	7	71.33	30.72
2	*2462.00	90.20 AV			1.82 H	7	59.48	30.72
3	2483.50	59.06 PK	74.00	-14.94	1.82 H	8	28.24	30.82
4	2483.50	45.74 AV	54.00	-8.26	1.82 H	8	14.92	30.82
5	4924.00	50.13 PK	74.00	-23.87	1.50 H	328	14.23	35.90
6	4924.00	42.91 AV	54.00	-11.09	1.50 H	328	7.01	35.90
7	7386.00	61.78 PK	74.00	-12.22	1.60 H	321	18.98	42.80
8	7386.00	42.73 AV	54.00	-11.27	1.60 H	321	-0.07	42.80

ANTENNA POLARITY & TEST DISTANCE: VERTICAL AT 3 M

No.	Freq. (MHz)	Emission Level (dBuV/m)	Limit (dBuV/m)	Margin (dB)	Antenna Height (m)	Table Angle (Degree)	Raw Value (dBuV)	Correction Factor (dB/m)
1	*2462.00	113.82 PK			1.05 V	177	83.10	30.72
2	*2462.00	100.76 AV			1.05 V	177	70.04	30.72
3	2483.50	69.48 PK	74.00	-4.52	1.04 V	170	38.66	30.82
4	2483.50	53.26 AV	54.00	-0.74	1.04 V	170	22.44	30.82
5	4924.00	52.61 PK	74.00	-21.39	1.49 V	31	16.71	35.90
6	4924.00	47.39 AV	54.00	-6.61	1.49 V	31	11.49	35.90
7	7386.00	61.65 PK	74.00	-12.35	1.44 V	265	18.85	42.80
8	7386.00	46.12 AV	54.00	-7.88	1.44 V	265	3.32	42.80

- REMARKS:**
1. Emission level (dBuV/m) = Raw Value (dBuV) + Correction Factor (dB/m).
 2. Correction Factor (dB/m) = Antenna Factor (dB/m) + Cable Factor (dB).
 3. The other emission levels were very low against the limit.
 4. Margin value = Emission level – Limit value.
 5. The limit value is defined as per 15.247.
 6. " * ": Fundamental frequency.

RESTRICTED BANDEDGE (DRAFT 802.11n (20MHz) MODE, CH1, HORIZONTAL)

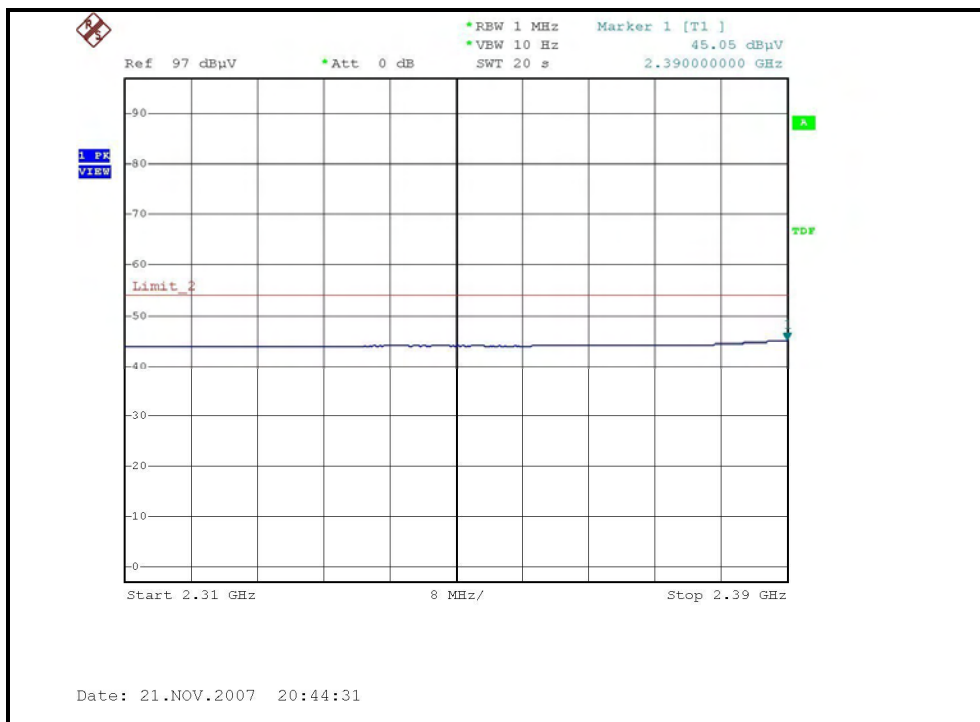
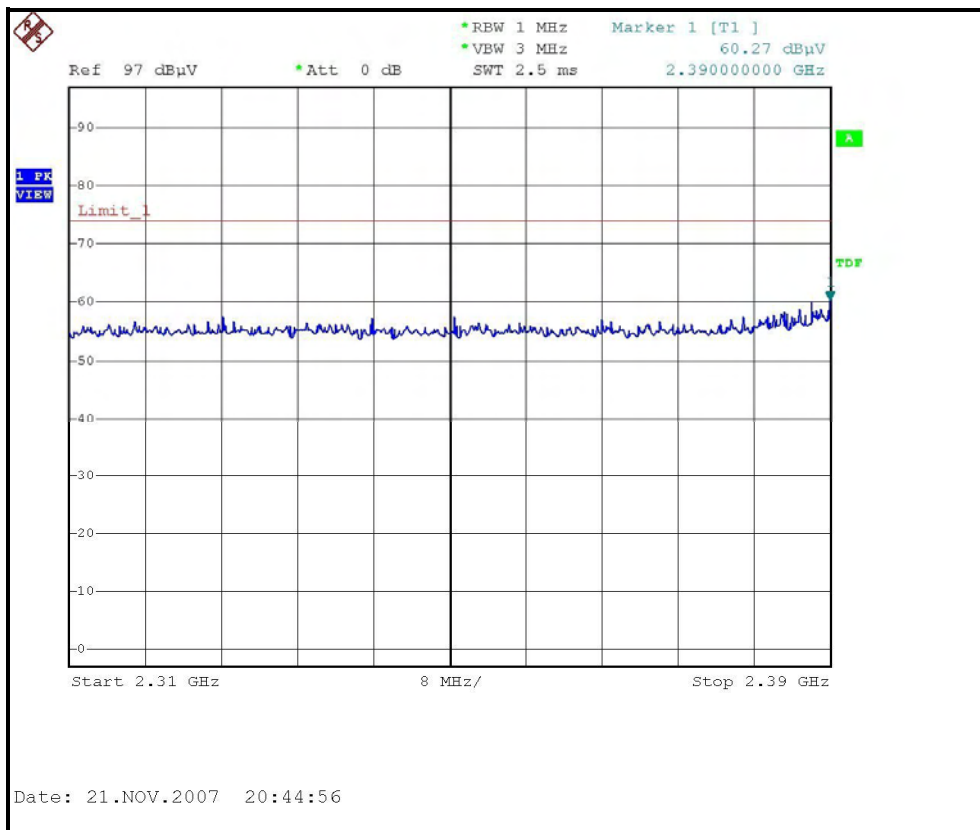

RESTRICTED BANDEDGE (DRAFT 802.11n (20MHz) MODE,CH1, VERTICAL)

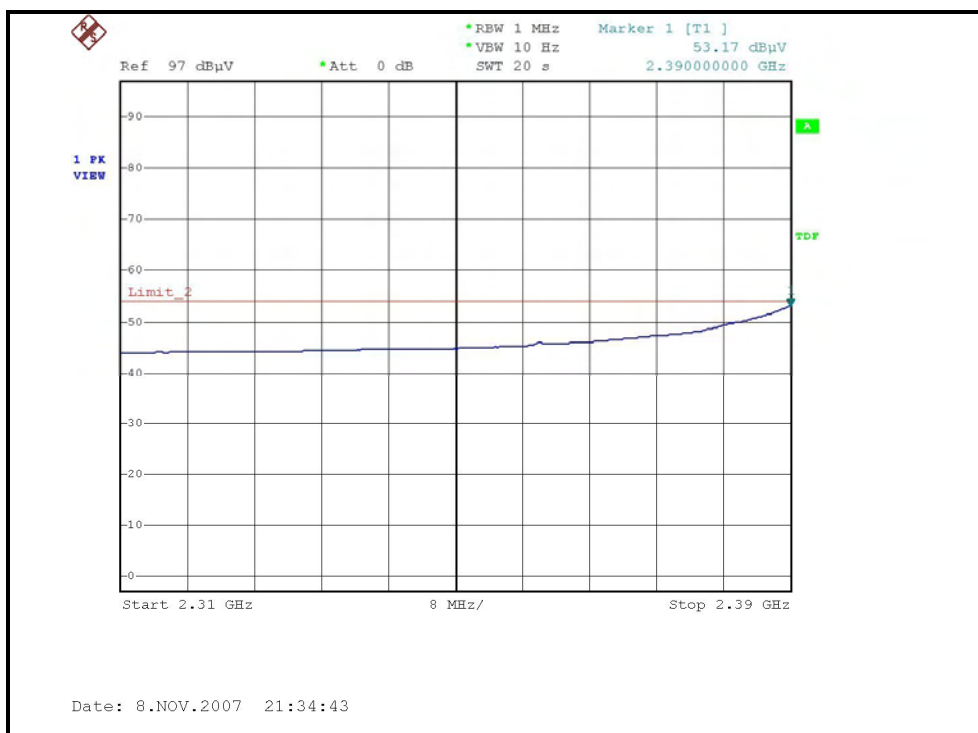
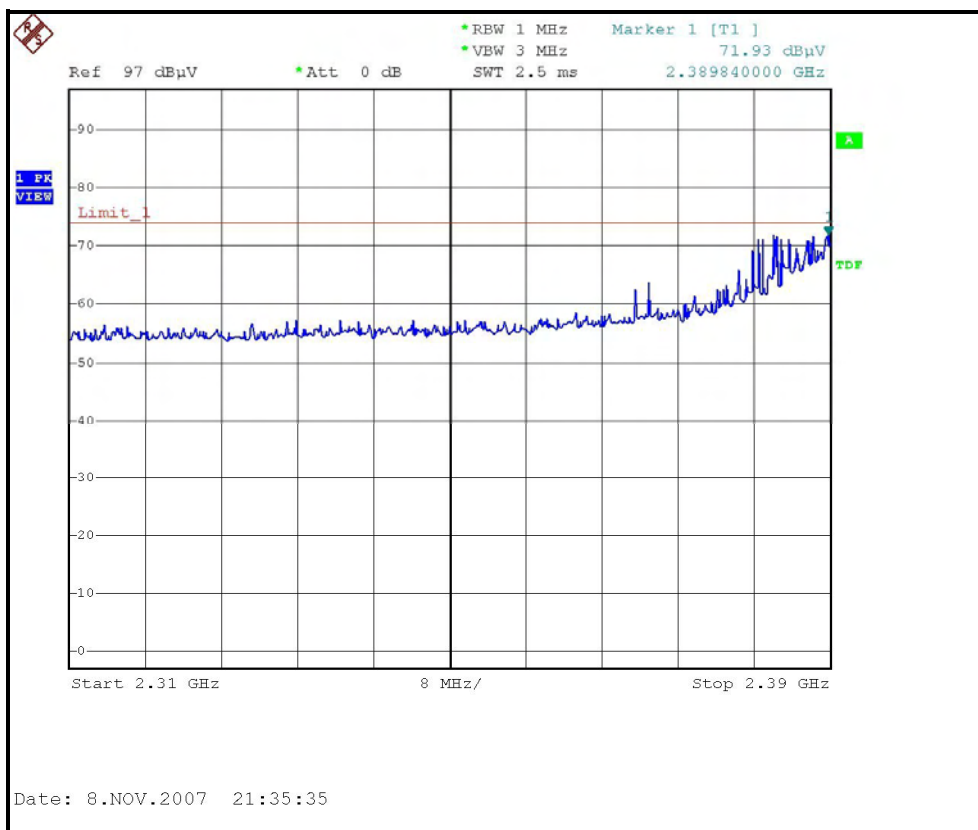

RESTRICTED BANDEDGE (DRAFT 802.11n (20MHz) MODE, CH11, HORIZONTAL)

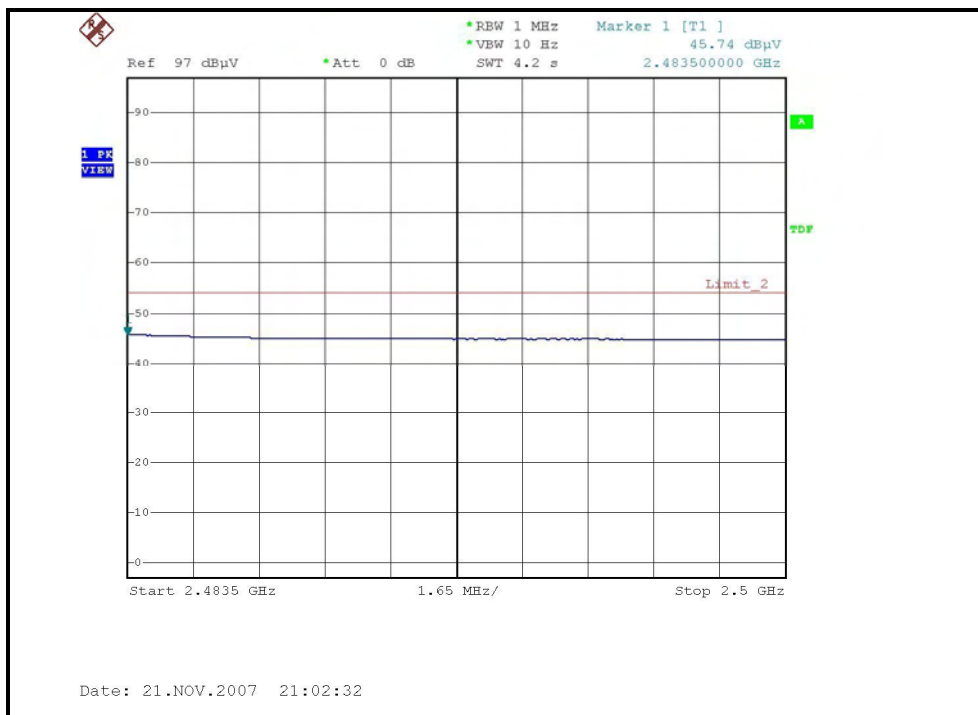
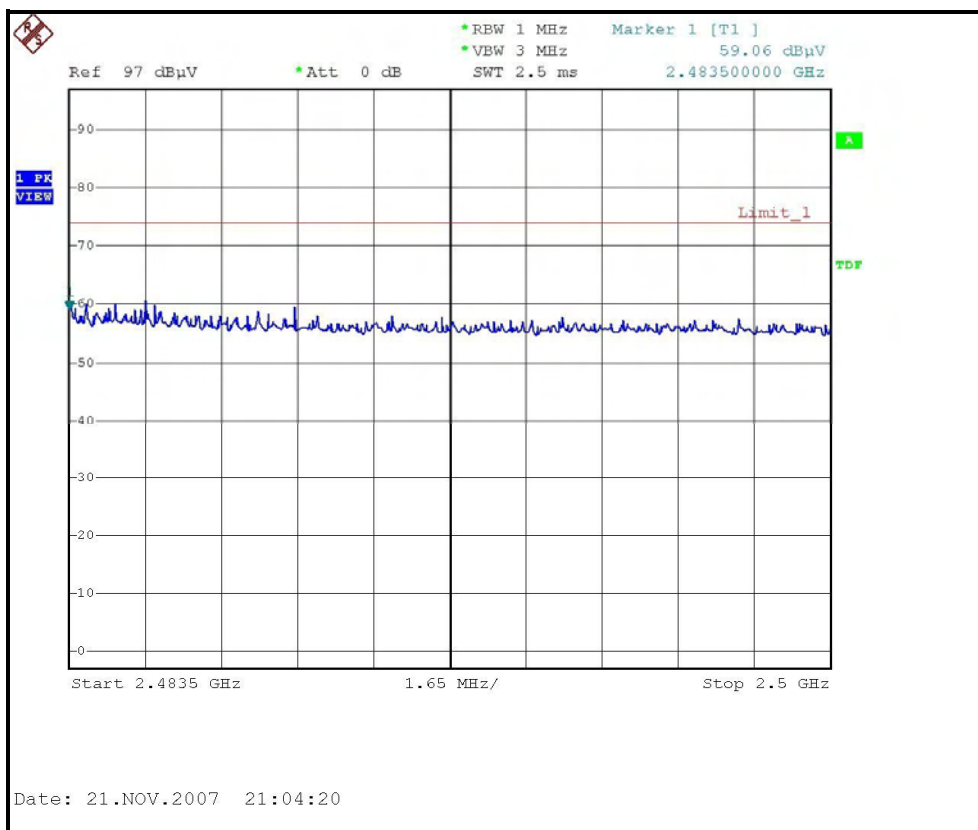

RESTRICTED BANDEDGE (DRAFT 802.11n (20MHz) MODE,CH11, VERTICAL)

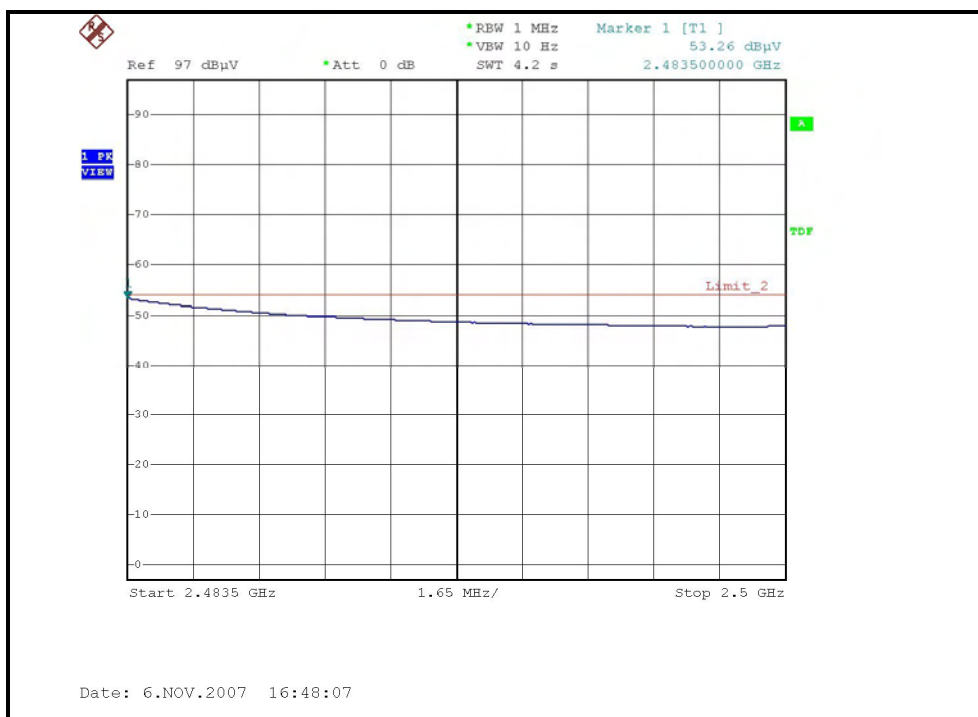
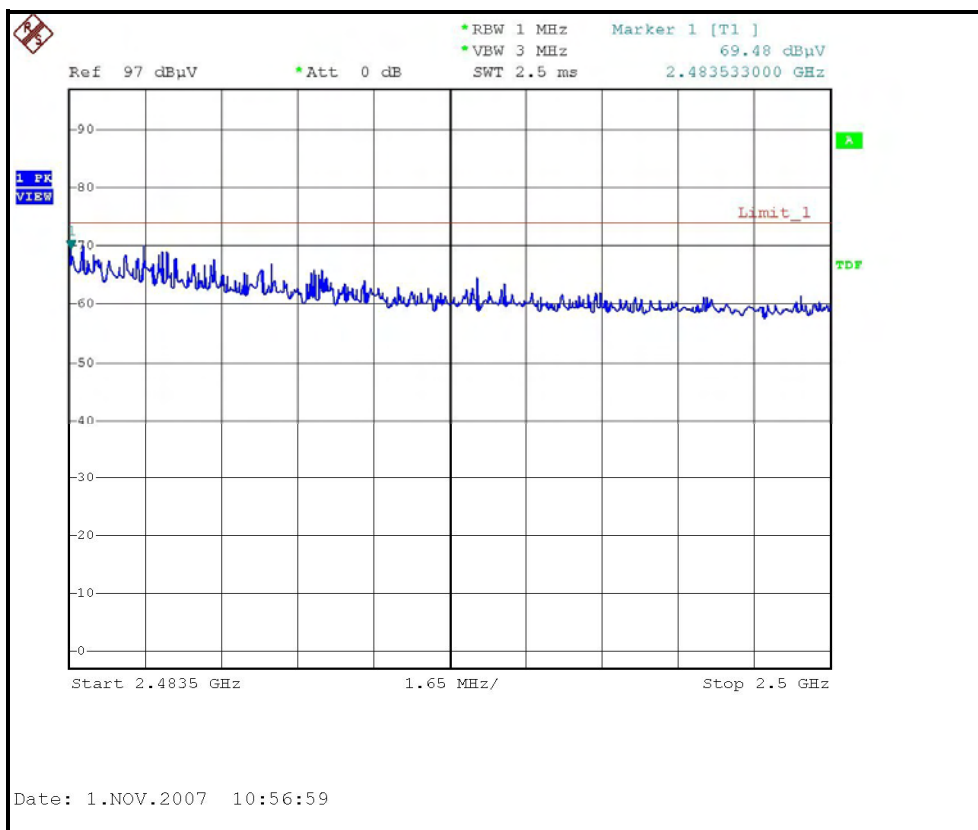

DRAFT 802.11n (40MHz) OFDM MODULATION:

EUT TEST CONDITION		MEASUREMENT DETAIL	
CHANNEL	Channel 1	FREQUENCY RANGE	1 ~ 25GHz
MODULATION TYPE	BPSK	INPUT POWER (SYSTEM)	120Vac, 60 Hz
TRANSFER RATE	13.5Mbps	DETECTOR FUNCTION	Peak(PK) Average (AV)
ENVIRONMENTAL CONDITIONS	22deg. C, 68%RH, 955hPa	TESTED BY	Wen Yu

ANTENNA POLARITY & TEST DISTANCE: HORIZONTAL AT 3 M

No.	Freq. (MHz)	Emission Level (dBuV/m)	Limit (dBuV/m)	Margin (dB)	Antenna Height (m)	Table Angle (Degree)	Raw Value (dBuV)	Correction Factor (dB/m)
1	2390.00	57.61 PK	74.00	-16.39	2.02 H	8	27.21	30.40
2	2390.00	45.22 AV	54.00	-8.78	2.02 H	8	14.82	30.40
3	*2422.00	98.69 PK			1.59 H	6	68.15	30.54
4	*2422.00	86.10 AV			1.59 H	6	55.56	30.54
5	4844.00	50.12 PK	74.00	-23.88	1.40 H	325	14.38	35.74
6	4844.00	43.28 AV	54.00	-10.72	1.40 H	325	7.54	35.74
7	7266.00	53.42 PK	74.00	-20.58	1.44 H	165	11.07	42.35
8	7266.00	39.49 AV	54.00	-14.51	1.44 H	165	-2.86	42.35

ANTENNA POLARITY & TEST DISTANCE: VERTICAL AT 3 M

No.	Freq. (MHz)	Emission Level (dBuV/m)	Limit (dBuV/m)	Margin (dB)	Antenna Height (m)	Table Angle (Degree)	Raw Value (dBuV)	Correction Factor (dB/m)
1	2390.00	67.90 PK	74.00	-6.10	1.06 V	279	37.51	30.40
2	2390.00	53.50 AV	54.00	-0.50	1.06 V	279	23.10	30.40
3	*2422.00	111.80 PK			1.08 V	166	81.26	30.54
4	*2422.00	97.80 AV			1.08 V	166	67.26	30.54
5	4844.00	52.00 PK	74.00	-22.00	1.70 V	138	16.26	35.74
6	4844.00	48.50 AV	54.00	-5.50	1.70 V	138	12.76	35.74
7	7266.00	52.83 PK	74.00	-21.17	1.49 V	262	10.48	42.35
8	7266.00	39.61 AV	54.00	-14.39	1.49 V	262	-2.74	42.35

- REMARKS:**
1. Emission level (dBuV/m) = Raw Value (dBuV) + Correction Factor (dB/m).
 2. Correction Factor (dB/m) = Antenna Factor (dB/m) + Cable Factor (dB).
 3. The other emission levels were very low against the limit.
 4. Margin value = Emission level – Limit value.
 5. The limit value is defined as per 15.247.
 6. " * ": Fundamental frequency.