

# FCC TEST REPORT

according to

## FCC Rules and Regulations

### Part 15 Subpart C

Applicant	Cisco-Linksys, LLC
Address	121 Theory Drive Irvine, CA 92612 USA
Equipment	Wireless-G Print Server
Model No.	WPS54G
FCC ID	Q87-WPS54G
Trade Name	Linksys

- The test result refers exclusively to the test presented test model / sample.,
- Without written approval of *Exclusive Certification Corp.* the test report shall not be reproduced except in full.

## Contents

1.	Report of Measurements and Examinations.....	3
1.1.	List of Measurements and Examinations .....	3
1.2.	Antenna Requirements.....	3
1.3.	Test of Conducted Emission .....	3
1.4.	Test of Radiated Emission.....	3
1.5.	6dB Bandwidth.....	3
1.6.	Maximum Peak Output Power .....	3
1.7.	Band Edges Measurement .....	3
1.8.	Power Spectral Density.....	3
1.9.	Restricted Bands of Operation.....	3
1.10.	Labeling Requirement .....	3
1.11.	RF Exposure .....	3
2.	Test Configuration of Equipment under Test.....	3
2.1.	Test Mode and Test Software.....	3
2.2.	Description of Test System .....	3
2.3.	Connection Diagram of Test System .....	3
2.4.	Feature of Equipment under Test .....	3
2.5.	RF Module Specifications .....	3
2.6.	History of this test report .....	3
3.	General Information of Test .....	3
4.	Test Result and Data.....	3
4.1.	Antenna Requirement .....	3
4.2.	Test Result of Conducted Emission .....	3
4.3.	RF Portion.....	3
4.4.	6dB Bandwidth Measurement Data.....	3
4.5.	Peak Output Power Measurement Data .....	3
4.6.	Band Edges Measurement Data .....	3
4.7.	Power Spectral Density Measurement Data.....	3
5.	List of Measuring Equipment Used.....	3
	Appendix A. Photographs of EUT.....	A1 ~ A6

# CERTIFICATE OF COMPLIANCE

according to

## FCC Rules and Regulations

### Part 15 Subpart C

Applicant	Cisco-Linksys, LLC
Address	121 Theory Drive Irvine, CA 92612 USA
Equipment	Wireless-G Print Server
Model No.	WPS54G
FCC ID	Q87-WPS54G

**I HEREBY CERTIFY THAT :**

The measurements shown in this test report were made in accordance with the procedures given in **ANSI C63.4**. The equipment was **passed** the test performed according to **FCC Rules and Regulations Part 15 Subpart C (2002)**. The test was carried out on Sep. 14, 2004 at *Exclusive Certification Corp.*

Signature

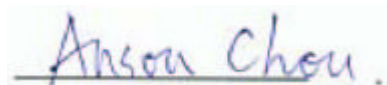

Anson Chou / Manager

## 1. Report of Measurements and Examinations

### 1.1. List of Measurements and Examinations

FCC Rule	Description of Test	Result
15.203	. Antenna Requirement	Pass
15.207	. Conducted Emission	Pass
15.209	. Radiated Emission	Pass
15.247(a)(2)	. 6dB Bandwidth	Pass
15.247(b)	. Maximum Peak Output Power	Pass
15.247(c)	. 100kHz Bandwidth of Frequency Band Edges	Pass
15.247(d)	. Power Spectral Density	Pass
1.1307 1.1310 2.1091 2.1093	. RF Exposure Compliance	Pass

Test by: Jerry

## 1.2. Antenna Requirements

### 1.2.1. Standard Applicable

For intentional device, according to FCC 47 CFR Section 15.203, an intentional radiator shall be designed to ensure that no antenna other than that furnished by the responsible party shall be used with the device.

And according to FCC 47 CFR Section 15.247 (b), if transmitting antennas of directional gain greater than 6dBi are used, the power shall be reduced by the amount in dB that the directional gain of the antenna exceeds 6dBi.

### 1.3. Test of Conducted Emission

Conducted Emissions were measured from 150 kHz to 30 MHz with a bandwidth of 9 KHz on the 115 VAC power and return leads of the EUT according to the methods defined in ANSI C63.4-1992 Section 3.1. The EUT was placed on a nonmetallic stand in a shielded room 0.8 meters above the ground plane as shown in section 2.2. The interface cables and equipment positioning were varied within limits of reasonable applications to determine the position produced maximum conducted emissions.

#### 1.3.1. Test Procedures

- a. The EUT was placed 0.4 meter from the conducting wall of the shielding room was kept at least 80 centimeters from any other grounded conducting surface.
- b. Connect EUT to the power mains through a line impedance stabilization network (LISN).
- c. All the support units are connecting to the other LISN.
- d. The LISN provides 50 ohm coupling impedance for the measuring instrument.
- e. The FCC states that a 50 ohm, 50 microhenry LISN should be used.
- f. Both sides of AC line were checked for maximum conducted interference.
- g. The frequency range from 150 kHz to 30 MHz was searched.
- h. Set the test-receiver system to Peak Detect Function and Specified Bandwidth with Maximum Hold Mode.

1.3.2. Typical Test Setup Layout of Conducted Emission

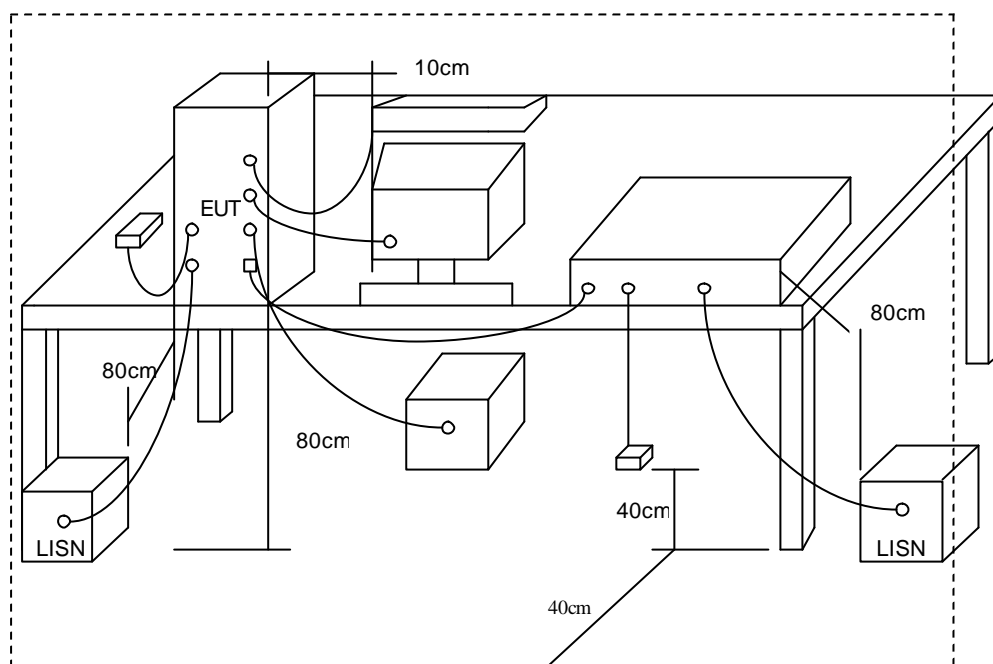

1.3.3. Conducted Emission Requirement

Except for A digital devices, for equipment that is designed to be connected to the public utility (AC) power line on any frequency voltage that is conducted back onto the AC power line on ant frequency or frequencies within the band 150KHz to 30MHz shall not exceed the limits in the following table, as measured using a 50μH/50 ohms line impedance stabilization network (LISN). Compliance with the provisions of this paragraph shall be based on the measurement of the Radio frequency voltage between each power line and ground at the power terminal. The lower limit applies at the band edges.

Frequency (MHz)	Quasi Peak (dB μ V)	Average (dB μ V)
0.15 – 0.5	66-56*	56-46*
0.5 – 5.0	56	46
5.0 – 30.0	60	50

## 1.4. Test of Radiated Emission

Radiated emissions from 30 MHz to 25 GHz were measured according to the methods defines in ANSI C63.4-2001. The EUT was placed, 0.8 meter above the ground plane, as shown in section 5.6.3. The interface cables and equipment positions were varied within limits of reasonable applications to determine the positions producing maximum radiated emissions

### 1.4.1. Test Procedures

1. The EUT was placed on a rotatable table top 0.8 meter above ground.
2. The EUT was set 3 meters from the interference receiving antenna which was mounted on the top of a variable height antenna tower.
3. The table was rotated 360 degrees to determine the position of the highest radiation.
4. The antenna is a broadband antenna and its height is varied between one meter and four meters above ground to find the maximum value of the field strength both horizontal polarization and vertical polarization of the antenna are set to make the measurement.
5. For each suspected emission the EUT was arranged to its worst case and then tune the antenna tower (from 1 M to 4 M) and turn table (from 0 degree to 360 degrees) to find the maximum reading.
6. Set the test-receiver system to Peak or CISPR quasi-peak Detect Function and specified bandwidth with Maximum Hold Mode.
7. If the emission level of the EUT in peak mode was 3 dB lower than the limit specified, then testing will be stopped and peak values of EUT will be reported, otherwise, the emissions which do not have 3 dB margin will be repeated one by one using the quasi-peak method and reported.
8. For testing above 1GHz, the emission level of the EUT in peak mode was 20dB lower than average limit (that means the emission level in peak mode also complies with the limit in average mode), then testing will be stopped and peak values of EUT will be reported, otherwise, the emissions will be measured in average mode again and reported.

### 1.4.2. Typical Test Setup Layout of Radiated Emission

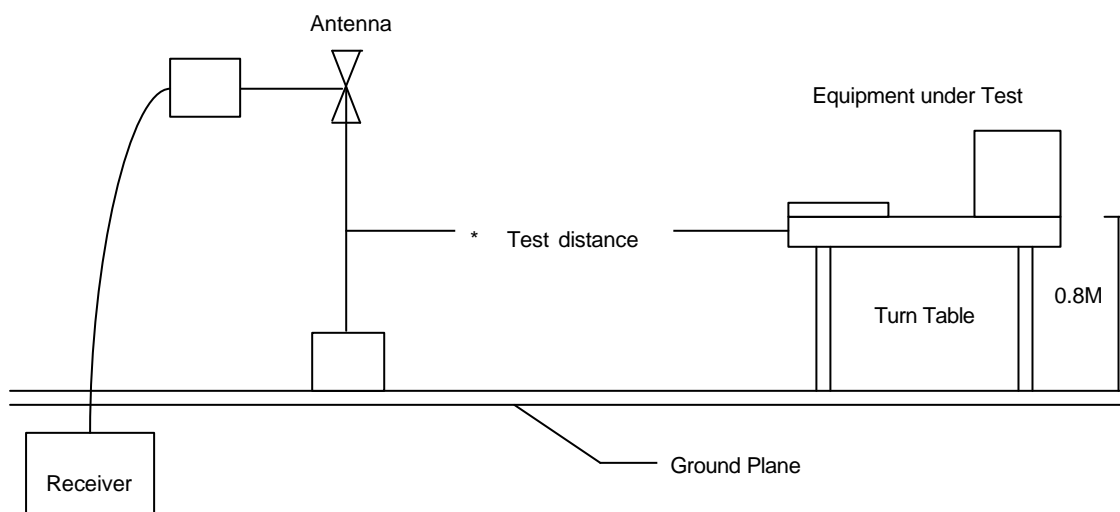



## 1.5. 6dB Bandwidth

### 1.5.1. Test Procedure :

1. The transmitter output was connected to the spectrum analyzer.
2. Set RBW of spectrum analyzer to 100 KHz and VBW to 100 KHz.
3. The 6 dB bandwidth is defined as the total spectrum the power of which is higher than peak power minus 6 dB.

### 1.5.2. Test Setup Layout :

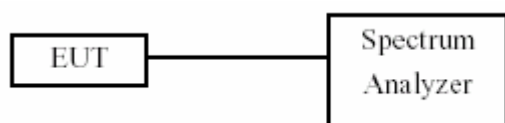

## 1.6. Maximum Peak Output Power

### 1.6.1. Test Procedure :

The antenna port ( RF output ) of the EUT was connected to the input ( RF input ) of a spectrum analyzer. Power was read directly from the spectrum analyzer and cable loss connection was added to the reading to obtain power at the EUT antenna terminal. The EUT Output Power was set to maximum to produce the worse case test result.

### 1.6.2. Test Setup Layout :

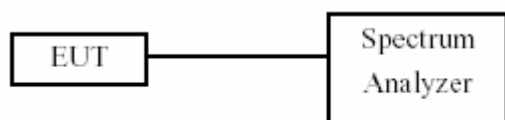

## 1.7. Band Edges Measurement

### 1.7.1. Test Procedure :

1. The transmitter output was connected to the spectrum analyzer via a low lose cable.
2. Set both RBW and VBW of spectrum analyzer to 100 KHz with convenient frequency span including 100 MHz bandwidth from band edge.
3. The band edges was measured and recorded.

## 1.8. Power Spectral Density

### 1.8.1. Test Procedure :

1. The transmitter output was connected to spectrum analyzer.
2. The spectrum analyzer' s resolution bandwidth were set at 3KHz RBW and 30KHz VBW as that of the fundamental frequency. Set the sweep time= $\text{span}/3\text{KHz}$ .
3. The power spectral density was measured and recorded.
4. The Sweep time is allowed to be longer than  $\text{span}/3\text{KHz}$  for a full response of the mixer in the spectrum analyzer.

### 1.8.2. Test Setup Layout :

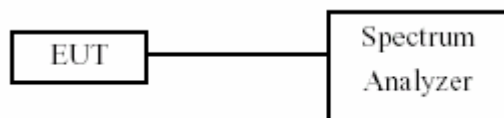

## 1.9. Restricted Bands of Operation

Only spurious emissions are permitted in any of the frequency bands listed below:

MHz	MHz	MHz	GHz
0.09000 – 0.11000	16.42000 – 16.42300	399.9 – 410.0	4.500 – 5.250
0.49500 – 0.505**	16.69475 – 16.69525	608.0 – 614.0	5.350 – 5.460
2.17350 – 2.19050	16.80425 – 16.80475	960.0 – 1240.0	7.250 – 7.750
4.12500 – 4.12800	25.50000 – 25.67000	1300.0 – 1427.0	8.025 – 8.500
4.17725 – 4.17775	37.50000 – 38.25000	1435.0 – 1626.5	9.000 – 9.200
4.20725 – 4.20775	73.00000 – 74.60000	1645.5 – 1646.5	9.300 – 9.500
6.21500 – 6.21800	74.80000 – 75.20000	1660.0 – 1710.0	10.600 – 12.700
6.26775 – 6.26825	108.00000 – 121.94000	1718.8 – 1722.2	13.250 – 13.400
6.31175 – 6.31225	123.00000 – 138.00000	2200.0 – 2300.0	14.470 – 14.500
8.29100 – 8.29400	149.90000 – 150.05000	2310.0 – 2390.0	15.350 – 16.200
8.36200 – 8.36600	156.52475 – 156.52525	2483.5 – 2500.0	17.700 – 21.400
8.37625 – 8.38675	156.70000 – 156.90000	2655.0 – 2900.0	22.010 – 23.120
8.41425 – 8.41475	162.01250 – 167.17000	3260.0 – 3267.0	23.600 – 24.000
12.29000 – 12.29300	167.72000 – 173.20000	3332.0 – 3339.0	31.200 – 31.800
12.51975 – 12.52025	240.00000 – 285.00000	3345.8 – 3358.0	36.430 – 36.500
12.57675 – 12.57725	322.00000 – 335.40000	3600.0 – 4400.0	Above 38.6
13.36000 – 13.41000			

\*\* : Until February 1, 1999, this restricted band shall be 0.490-0.510 MHz

## 1.10. Labeling Requirement

The device shall bear the following statement in a conspicuous location on the device:

This device complies with part 15 of the FCC Rules. Operation is subject to the following two conditions: (1) This device may not cause harmful interference, and (2) this device must accept any interference received, including interference that may cause undesired operation.

### 1.11. RF Exposure

FCC Rules and Regulations Part 1.1307, 1.1310, 2.1091, 2.1093:

RF Exposure Compliance

#### 1.11.1. Limit For Maximum Permissible Exposure (MPE)

##### (A) Limits for Occupational / Controlled Exposure

Frequency Range (MHz)	Electric Field Strength (E) (V/m)	Magnetic Field Strength (H) (A/m)	Power Density (S) (mW/ cm <sup>2</sup> )	Averaging Time  E  <sup>2</sup> ,  H  <sup>2</sup> or S (minutes)
0.3-3.0	614	1.63	(100)*	6
3.0-30	1842/f	4.89/f	(900/f)*	6
30-300	61.4	0.163	1.0	6
300-1500			F/300	6
1500-100,000			5	6

##### (B) Limits for General Population / Uncontrolled Exposure

Frequency Range (MHz)	Electric Field Strength (E) (V/m)	Magnetic Field Strength (H) (A/m)	Power Density (S) (mW/cm <sup>2</sup> )	Averaging Time  E  <sup>2</sup> ,  H  <sup>2</sup> or S ( minutes )
0.3-1.34	614	1.63	(100)*	30
1.34-30	824/f	2.19/f	(180/f)*	30
30-300	27.5	0.073	0.2	30
300-1500			F/1500	30
1500-100,000			1.0	30

F=frequency in MHz

\*Plane-wave equivalent power density

## 1.11.2. MPE Calculations

$$E \text{ (V/m)} = \frac{\sqrt{30 \cdot P \cdot G}}{d} \quad \text{Power Density: } Pd \text{ (mW/cm}^2\text{)} = \frac{E^2}{3770}$$

E = Electric field (V/m)

P = Peak output power (W)

G = Antenna numeric gain (numeric)

d = Separation distance (m)

Because the EUT is belong to General Population/ Uncontrolled Exposure. So the Limit of Power Density is 10 W/m<sup>2</sup>. We can change the formula to:

$$d = \sqrt{\frac{30 \cdot P \cdot G}{3770}}$$

## 1.11.3. FCC Radiation Exposure Statement

This equipment complies with FCC radiation exposure limits set forth for an uncontrolled environment. In order to avoid the possibility of exceeding the FCC radio frequency exposure limits, human proximity to the antenna shall not be less than 20cm (8 inches) during normal operation. Proposed RF exposure safety information to include in User's Manual.

## 2. Test Configuration of Equipment under Test

### 2.1. Test Mode and Test Software

The following test mode and test software was performed for conduction and radiation test:

- 802.11b (CH LO: 2412MHz) • 802.11b (CH MID: 2437MHz) • 802.11b (CH HI: 2462MHz)
- 802.11g (CH LO: 2412MHz) • 802.11g (CH MID: 2437MHz) • 802.11g (CH HI: 2462MHz)
- An executive programs, "DUTAPIDLL.exe" Application under WIN XP.

### 2.2. Description of Test System

#### Conduction

Device	Manufacturer	Model No.	Description
PC	IBM	IGV	Power Cable, Unshielding 1.8 m
Monitor	SlimAGE	510A	Power Cable, Adapter Unshielding 1.8 m Data Cable, VGA shielding 1.35 m
Keyboard	IBM	KB-0225	Data Cable, PS2 shielding 1.85 m
Mouse	IBM	MO28VO	Data Cable, USB shielding 1.85 m
Notebook (Remote Site)	IBM	R40(2723-BV1)	Power Cable, Adapter Unshielding 1.8 m
Printer	EPSON	C43UX	Power Cable, Unshielding 1.8 m Data Cable, USB Shielding 1.5 m
AP Router (Remote Site)	Sercomm	ARM804	Power Cable, Adapter Unshielding 1.8 m

#### Radiation

Device	Manufacturer	Model No.	Description
PC	IBM	IGV	Power Cable, Unshielding 1.8 m
Monitor	IBM	90B88M6	Power Cable, Unshielding 1.8 m Data Cable, USB shielding 1.35 m
Keyboard	IBM	KB-0225	Data Cable, PS2 shielding 1.85 m
Mouse	IBM	MO28VO	Data Cable, USB shielding 1.85 m
Notebook (Remote Site)	IBM	R40(2723-BV1)	Power Cable, Adapter Unshielding 1.8 m
Printer	EPSON	C43UX	Power Cable, Unshielding 1.8 m Data Cable, USB Shielding 1.5 m
AP Router (Remote Site)	Sercomm	ARM804	Power Cable, Adapter Unshielding 1.8 m

#### Use Cable:

##### Conduction

Cable	Description
RJ-45	Unshielding, 1.8m

##### Radiation

Cable	Description
RJ-45	Unshielding, 0.6m

### 2.3. Connection Diagram of Test System

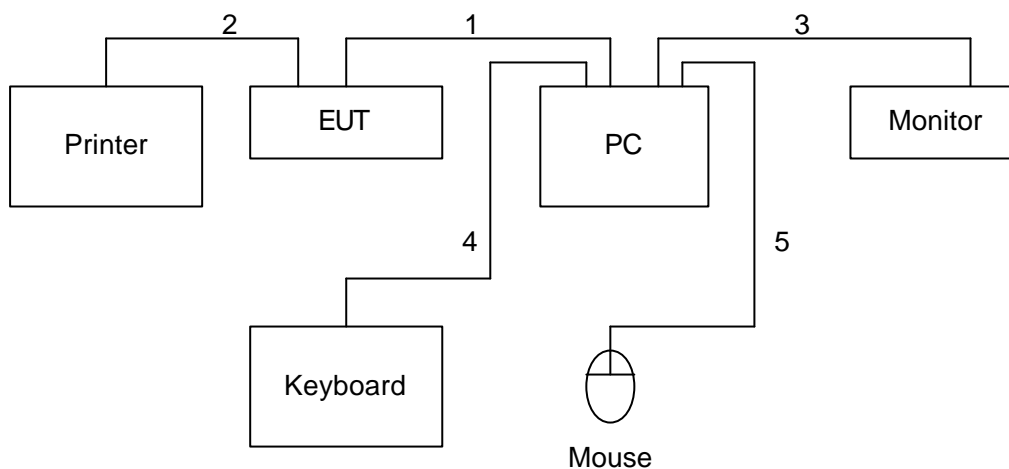

1. The TP cable is connected from PC to the EUT.
2. The I/O cable is connected from EUT to the printer.
3. The I/O cable is connected from PC to the Monitor.
4. The I/O cable is connected from PC to the Keyboard.
5. The I/O cable is connected from PC to the Mouse.

### 2.4. Feature of Equipment under Test

Standards	IEEE 802.11g, IEEE 802.11b, IEEE 802.3, USB 2.0
Ports	Power, Ethernet, USB Printer
Button	Reset
Cabling Type	USB 2.0, UTP CAT5
LEDs	Power, Ethernet, Wireless, USB
Security Features	WEP, WPA-PSK
WEP Key Bits	64, 128
Dimensions (W x H x D)	5.24" x 0.98" x 2.76" (133 mm x 25 mm x 70 mm)
Unit Weight	3.80 oz. (0.11 kg)
Power	5 V DC, 2A
Certifications	FCC, CE
Operating Temp.	0°C to 40°C (32°F to 104°F)
Storage Temp.	-20°C to 70°C (-4°F to 158°F)
Operating Humidity	10% to 85%, Non-Condensing
Storage Humidity	5% to 90%, Non-Condensing

**2.5. RF Module Specifications**

Type of Modulation	BPSK,QPSK,CCK-OFDM,OFDM
Number of Channels	USA/Canada: 11 ; European: 13; Japan: 13, 14
Frequency Band	2412MHz~2484MHz
Carrier Frequency of each channel	2412,2417,2422,2427,2432,2437,2442, 2447,2452,2457,2462,2467,2472, 2484MHz
Bandwidth of each channel	16MHz/802.11g;22MHz/802.11b
Maximum Output Power to Antenna	20dBm
IF & L.O. frequency	374MHz
Antenna Type / Class and Gain	1.8dBi
Power Rating (DC/AC , Voltage)	DC5V,2A
Basic function of product	Wireless-G USB 2.0 1-Port Print Server
Temperature Range (Operating)	Normal 0~40 ℃

**2.6. History of this test report**

ORIGINAL.



### 3. General Information of Test

Test Site:	Exclusive Certification Corp. 4F-2, No. 28, Lane 78, Xing-Ai Rd. Nei-hu, Taipei City 114 Taiwan R.O.C.
Test Site Location (OATS1-SD):	No.68-1, Shihbachongsi, shihding Township, Taipei County 223, Taiwan, R.O.C.
Test Voltage:	AC 110V/ 60Hz
Test in Compliance with:	ANSI C63.4-1992 FCC Part 15 Subpart C
Frequency Range Investigated:	Conducted: from 150kHz to 30 MHz Radiation: from 30 MHz to 24620MHz
Test Distance:	1.The test distance of radiated emission above 1GHz from antenna to EUT is 3 M. 2.The test distance of radiated emission below 1GHz from antenna to EUT is 10 M.

## 4. Test Result and Data

### 4.1. Antenna Requirement

#### 4.1.1. Antenna Construction and Directional Gain

Antenna type: Integral dipole antenna.

Antenna Gain: 1.8 dBi.

### 4.2. Test Result of Conducted Emission

EUT : WPS54G  
 Power : 110V 60Hz  
 Test Mode : 802.11b CH L0  
 Memo :

Pol/Phase : NEUTRAL  
 Temperature : 26 °C  
 Humidity : 59 %

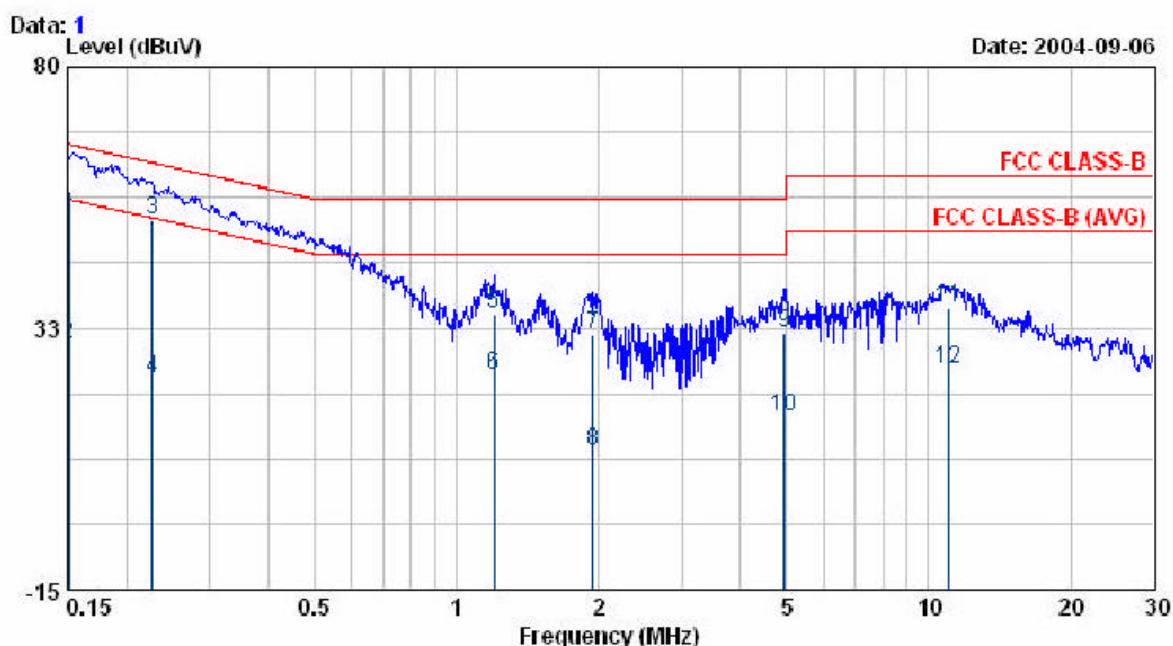

Freq	Read Level	Factor	Level	Limit	Over Limit	Remark
MHz	dBuV	dB	dBuV	dBuV	dBuV	
0.151	57.04	0.40	57.44	65.96	-8.52	QP
0.151	29.25	0.40	29.65	55.96	-26.31	AVERAGE
0.227	51.90	0.42	52.32	62.57	-10.24	QP
0.227	22.70	0.42	23.12	52.57	-29.44	AVERAGE
1.203	34.50	0.52	35.02	56.00	-20.98	QP
1.203	23.40	0.52	23.92	46.00	-22.08	AVERAGE
1.947	30.60	0.54	31.14	56.00	-24.86	QP
1.947	9.60	0.54	10.14	46.00	-35.86	AVERAGE
4.951	31.00	0.61	31.61	56.00	-24.39	QP
4.951	15.80	0.61	16.41	46.00	-29.59	AVERAGE
11.056	35.44	0.73	36.17	60.00	-23.83	QP
11.056	24.35	0.73	25.08	50.00	-24.92	AVERAGE

EUT : WPS54G  
 Power : 110V 60Hz  
 Test Mode : 802.11b CH LO  
 Memo :

Pol/Phase : LINE  
 Temperature : 26 °C  
 Humidity : 59 %

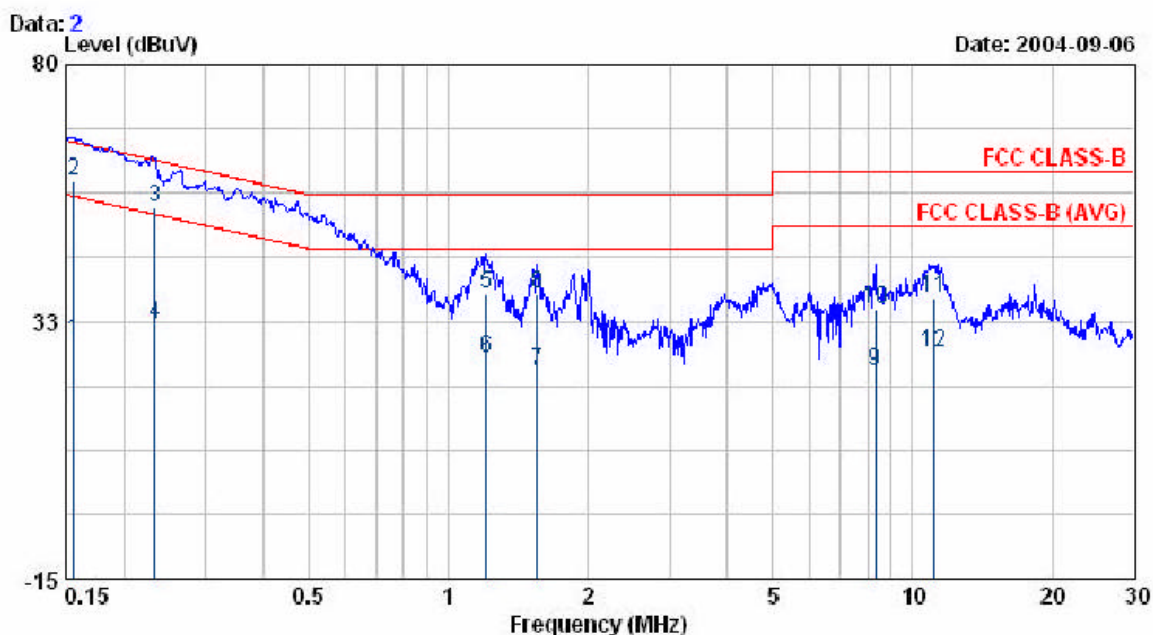

Freq	Read Level	Factor	Level	Limit	Over Limit	Remark
MHz	dBuV	dB	dBuV	dBuV	dBuV	
0.156	28.53	0.40	28.93	55.67	-26.74	AVERAGE
0.156	58.10	0.40	58.50	65.67	-7.17	QP
0.234	53.15	0.43	53.58	62.32	-8.74	QP
0.234	31.43	0.43	31.86	52.32	-20.46	AVERAGE
1.209	37.00	0.52	37.52	56.00	-18.48	QP
1.209	25.12	0.52	25.64	46.00	-20.36	AVERAGE
1.556	22.70	0.53	23.23	46.00	-22.77	AVERAGE
1.556	37.00	0.53	37.53	56.00	-18.47	QP
8.315	22.75	0.61	23.36	50.00	-26.64	AVERAGE
8.315	34.13	0.61	34.74	60.00	-25.26	QP
11.090	36.34	0.66	37.00	60.00	-23.00	QP
11.090	26.13	0.66	26.79	50.00	-23.21	AVERAGE

EUT : WPS54G  
 Power : 110W 60Hz  
 Test Mode : 802.11b CH MID  
 Memo :

Pol/Phase : NEUTRAL  
 Temperature : 26 °C  
 Humidity : 59 %

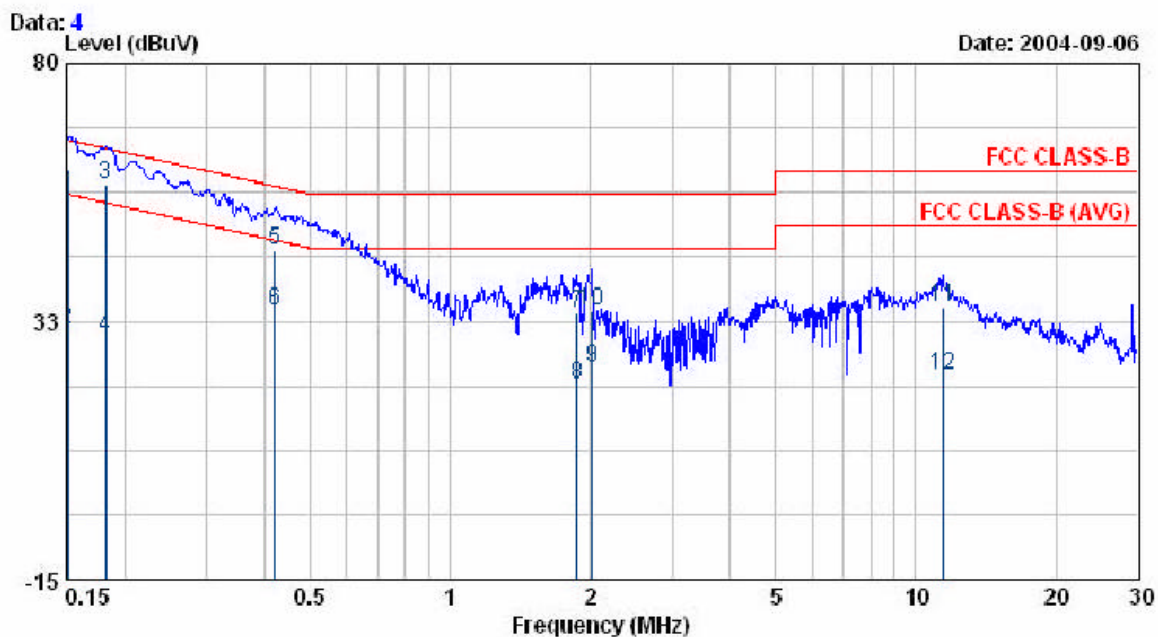

Freq	Read Level	Factor	Level	Limit	Over Limit	Remark
MHz	dBuV	dB	dBuV	dBuV	dBuV	
0.151	60.16	0.40	60.56	65.94	-5.38	QP
0.151	30.57	0.40	30.97	55.94	-24.97	AVERAGE
0.182	57.28	0.41	57.69	64.38	-6.69	QP
0.182	28.96	0.41	29.37	54.38	-25.01	AVERAGE
0.420	45.00	0.46	45.46	57.46	-12.00	QP
0.420	34.01	0.46	34.47	47.46	-12.99	AVERAGE
1.878	33.60	0.54	34.14	56.00	-21.86	QP
1.878	20.30	0.54	20.84	46.00	-25.16	AVERAGE
2.018	23.26	0.54	23.80	46.00	-22.20	AVERAGE
2.018	33.80	0.54	34.34	56.00	-21.66	QP
11.444	34.30	0.73	35.03	60.00	-24.97	QP
11.444	21.92	0.73	22.65	50.00	-27.35	AVERAGE

EUT : WPS54G  
 Power : 110W 60Hz  
 Test Mode : 802.11b CH MID  
 Memo :

Pol/Phase : LINE  
 Temperature : 26 °C  
 Humidity : 59 %

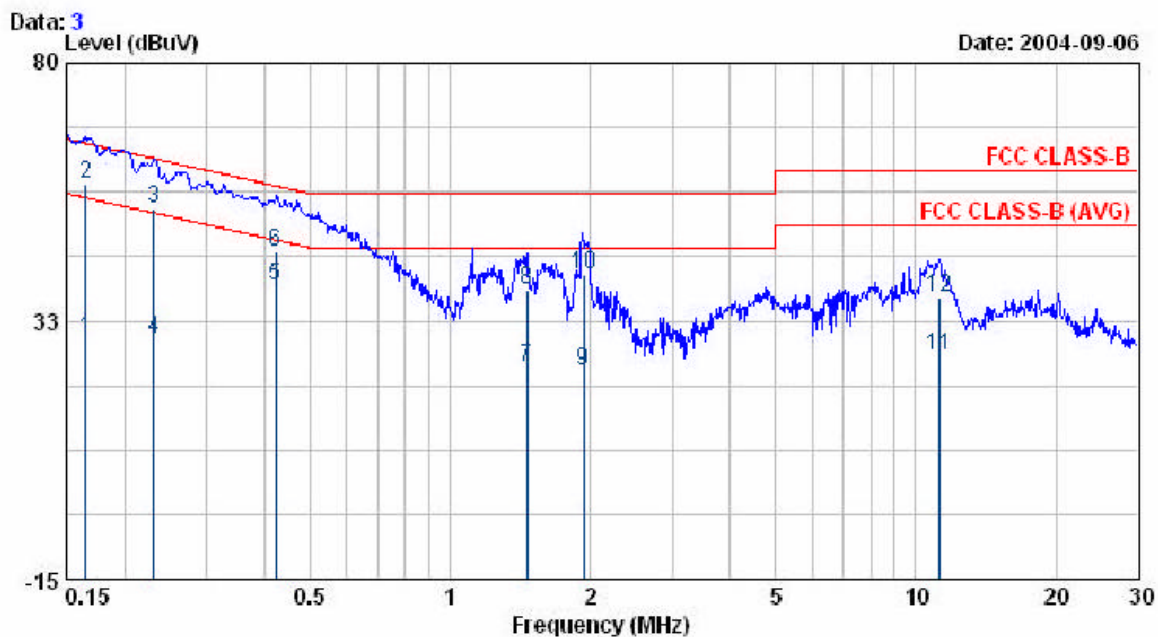

Freq	Read Level	Factor	Level	Limit	Over Limit	Remark
MHz	dBuV	dB	dBuV	dBuV	dBuV	
0.165	28.70	0.41	29.11	55.21	-26.10	AVERAGE
0.165	57.20	0.41	57.61	65.21	-7.60	QP
0.232	52.90	0.43	53.33	62.39	-9.07	QP
0.232	28.74	0.43	29.17	52.39	-23.23	AVERAGE
0.422	38.63	0.46	39.09	47.41	-8.31	AVERAGE
0.422	44.80	0.46	45.26	57.41	-12.14	QP
1.464	23.49	0.53	24.02	46.00	-21.98	AVERAGE
1.464	37.60	0.53	38.13	56.00	-17.87	QP
1.938	22.90	0.54	23.44	46.00	-22.56	AVERAGE
1.938	40.60	0.54	41.14	56.00	-14.86	QP
11.274	25.41	0.66	26.07	50.00	-23.93	AVERAGE
11.274	36.20	0.66	36.86	60.00	-23.14	QP



EUT : WPS54G  
 Power : 110W 60Hz  
 Test Mode : 802.11b CH HI  
 Memo :

Pol/Phase : NEUTRAL  
 Temperature : 26 °C  
 Humidity : 59 %

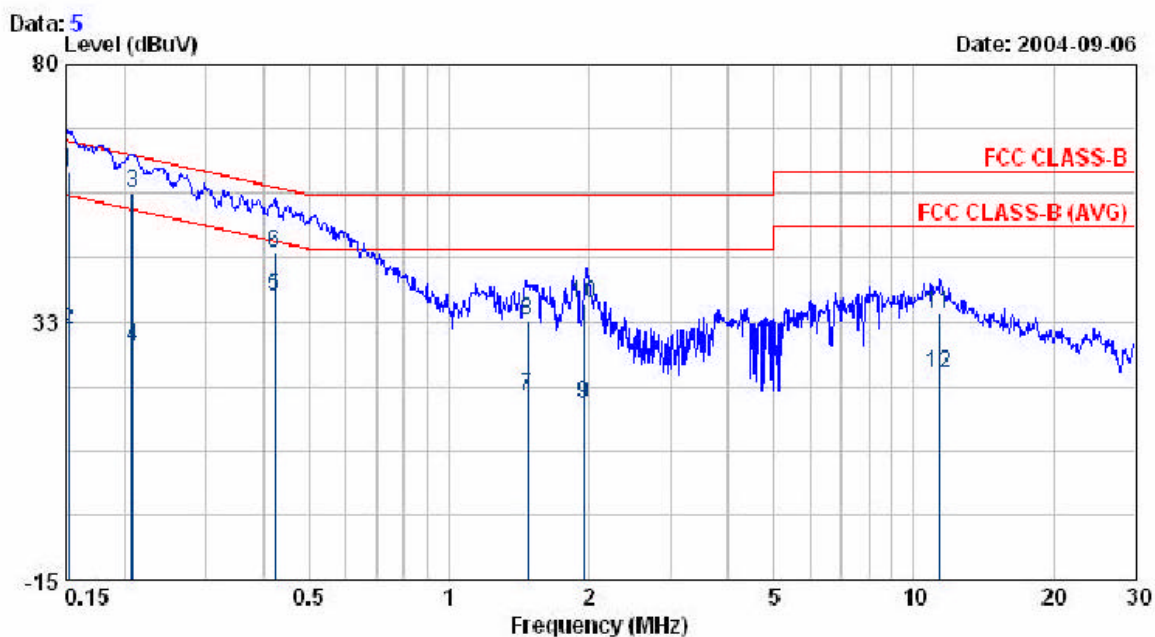

Freq	Read Level	Factor	Level	Limit	Over Limit	Remark
MHz	dBuV	dB	dBuV	dBuV	dBuV	
0.153	59.90	0.40	60.30	65.85	-5.55	QP
0.153	30.40	0.40	30.80	55.85	-25.05	AVERAGE
0.209	55.90	0.42	56.32	63.24	-6.93	QP
0.209	27.35	0.42	27.77	53.24	-25.48	AVERAGE
0.422	36.66	0.46	37.12	47.42	-10.30	AVERAGE
0.422	44.90	0.46	45.36	57.42	-12.06	QP
1.480	18.09	0.53	18.62	46.00	-27.38	AVERAGE
1.480	32.10	0.53	32.63	56.00	-23.37	QP
1.952	16.92	0.54	17.46	46.00	-28.54	AVERAGE
1.952	35.18	0.54	35.72	56.00	-20.28	QP
11.385	33.24	0.73	33.97	60.00	-26.03	QP
11.385	22.14	0.73	22.87	50.00	-27.13	AVERAGE

EUT : WPS54G  
 Power : 110V 60Hz  
 Test Mode : 802.11b CH HI  
 Memo :

Pol/Phase : LINE  
 Temperature : 26 °C  
 Humidity : 59 %

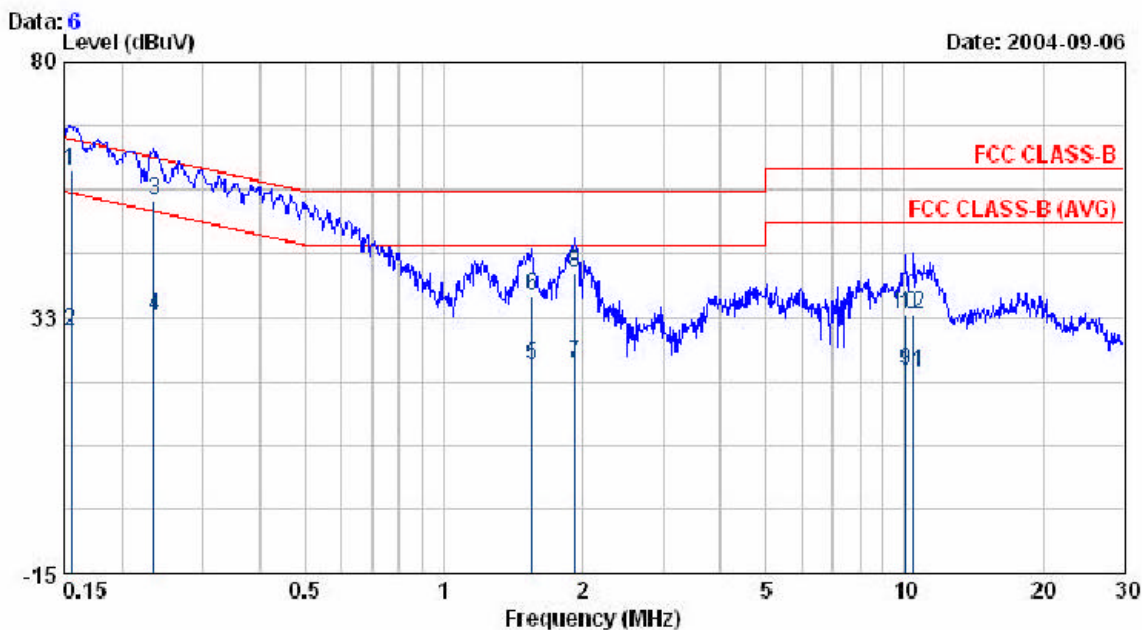

Freq	Read Level	Factor	Level	Limit	Over Limit	Remark
MHz	dBuV	dB	dBuV	dBuV	dBuV	
0.155	59.48	0.40	59.88	65.71	-5.82	QP
0.155	29.35	0.40	29.75	55.71	-25.95	AVERAGE
0.235	53.69	0.43	54.12	62.26	-8.14	QP
0.235	32.10	0.43	32.53	52.26	-19.73	AVERAGE
1.552	23.21	0.53	23.74	46.00	-22.26	AVERAGE
1.552	36.00	0.53	36.53	56.00	-19.47	QP
1.928	23.40	0.54	23.94	46.00	-22.06	AVERAGE
1.928	40.10	0.54	40.64	56.00	-15.36	QP
10.068	21.86	0.63	22.49	50.00	-27.51	AVERAGE
10.068	32.29	0.63	32.92	60.00	-27.08	QP
10.447	21.63	0.64	22.27	50.00	-27.73	AVERAGE
10.447	32.50	0.64	33.14	60.00	-26.86	QP