



**DFS PORTION OF  
FCC CFR47 PART 15 SUBPART E  
AND  
INDUSTRY CANADA RSS-210 ISSUE 7  
CERTIFICATION TEST REPORT FOR  
DUAL-BAND WIRELESS-N NOTEBOOK ADAPTER**

**BRAND NAME: LINKSYS**

**MODEL NUMBER: WPC600N**

**FCC ID: Q87-WPC600NV11**

**IC: 3839A-WPC6NV11**

**REPORT NUMBER: 07U11175-1**

**ISSUE DATE: JULY 5, 2007**

*Prepared for*  
**CISCO-LINKSYS LLC  
121 THEORY DRIVE  
IRVINE, CA 92617, USA**

*Prepared by*  
**COMPLIANCE CERTIFICATION SERVICES  
47173 BENICIA STREET  
FREMONT, CA 94538, USA  
TEL: (510) 771-1000  
FAX: (510) 661-0888**



**NVLAP LAB CODE 200065-0**

Revision History

| <u>Rev.</u> | <u>Issue<br/>Date</u> | <u>Revisions</u> | <u>Revised By</u> |
|-------------|-----------------------|------------------|-------------------|
| --          | 07/05/07              | Initial Issue    | M. Heckrotte      |

## TABLE OF CONTENTS

|   |           |
|---|-----------|
| <b>1. ATTESTATION OF TEST RESULTS.....</b>  | <b>4</b>  |
| <b>2. TEST METHODOLOGY .....</b>  | <b>5</b>  |
| <b>3. FACILITIES AND ACCREDITATION .....</b>  | <b>5</b>  |
| <b>4. CALIBRATION AND UNCERTAINTY.....</b>  | <b>5</b>  |
| 4.1. MEASURING INSTRUMENT CALIBRATION.....  | 5         |
| 4.2. MEASUREMENT UNCERTAINTY.....   | 5         |
| <b>5. DYNAMIC FREQUENCY SELECTION .....</b>   | <b>6</b>  |
| 5.1. OVERVIEW.....  | 6         |
| 5.1.1. LIMITS .....   | 6         |
| 5.1.2. §15.407 (h) and FCC 06-96 APPENDIX “COMPLIANCE MEASUREMENT<br>PROCEDURES FOR LIMITS..... | 6         |
| 5.1.3. TEST AND MEASUREMENT SYSTEM .....  | 9         |
| 5.1.4. DESCRIPTION OF EUT WITH RESPECT TO FCC 06-96 REQUIREMENTS .....                          | 14        |
| 5.2. RESULTS FOR 20 MHz BANDWIDTH CONFIGURATION .....   | 15        |
| 5.2.1. TEST CHANNEL AND METHOD .....  | 15        |
| 5.2.2. PLOTS OF RADAR WAVEFORM, AND WLAN TRAFFIC .....  | 15        |
| 5.2.3. MOVE TIME AND CHANNEL CLOSING TRANSMISSION TIME.....                                     | 17        |
| 5.3. RESULTS FOR 40 MHz BANDWIDTH CONFIGURATION .....   | 22        |
| 5.3.1. TEST CHANNEL AND METHOD .....  | 22        |
| 5.3.2. PLOTS OF RADAR WAVEFORM, AND WLAN TRAFFIC .....  | 22        |
| 5.3.3. CHANNEL MOVE TIME AND CHANNEL CLOSING TRANSMISSION TIME.....                             | 24        |
| <b>6. SETUP PHOTOS.....</b>   | <b>29</b> |

## 1. ATTESTATION OF TEST RESULTS

**COMPANY NAME:** CISCO-LINKSYS LLC  
121 THEORY DRIVE  
IRVINE, CA 92617, USA

**EUT DESCRIPTION:** DUAL-BAND WIRELESS-N NOTEBOOK ADAPTER

**BRAND NAME:** LINKSYS

**MODEL:** WPC600N

**SERIAL NUMBER:** GM13911

**DATE TESTED:** JULY 3, 2007

| APPLICABLE STANDARDS                    |                         |
|---|-------------------------|
| STANDARD                                | TEST RESULTS            |
| DFS PORTION OF<br>FCC PART 15 SUBPART E | NO NON-COMPLIANCE NOTED |
| DFS PORTION OF<br>IC RSS-210 ISSUE 7    | NO NON-COMPLIANCE NOTED |

Compliance Certification Services, Inc. tested the above equipment in accordance with the requirements set forth in the above standards. The test results show that the equipment tested is capable of demonstrating compliance with the requirements as documented in this report.

**Note:** The results documented in this report apply only to the tested sample, under the conditions and modes of operation as described herein. This document may not be altered or revised in any way unless done so by Compliance Certification Services and all revisions are duly noted in the revisions section. Any alteration of this document not carried out by Compliance Certification Services will constitute fraud and shall nullify the document. No part of this report may be used to claim product certification, approval, or endorsement by NVLAP, NIST, or any government agency.

Approved & Released For CCS By:



MICHAEL HECKROTTE  
ENGINEERING MANAGER  
COMPLIANCE CERTIFICATION SERVICES

Tested By:



YOBİ ZHOU  
EMC ENGINEER  
COMPLIANCE CERTIFICATION SERVICES

## 2. TEST METHODOLOGY

The tests documented in this report were performed in accordance with FCC CFR 47 Part 15, RSS-210 Issue 7, and FCC 06-96 APPENDIX "COMPLIANCE MEASUREMENT PROCEDURES FOR UNLICENSED-NATIONAL INFORMATION INFRASTRUCTURE DEVCIES OPERATING IN THE 5250-5350 MHz AND 5470-5725 MHz BANDS INCORPORATING DYNAMIC FREQUENCY SELECTION".

## 3. FACILITIES AND ACCREDITATION

The test sites and measurement facilities used to collect data are located at 47173 Benicia Street, Fremont, California, USA. The sites are constructed in conformance with the requirements of ANSI C63.4, ANSI C63.7 and CISPR Publication 22. All receiving equipment conforms to CISPR Publication 16-1, "Radio Interference Measuring Apparatus and Measurement Methods."

CCS is accredited by NVLAP, Laboratory Code 200065-0. The full scope of accreditation can be viewed at <http://www.ccsemc.com>.

## 4. CALIBRATION AND UNCERTAINTY

### 4.1. MEASURING INSTRUMENT CALIBRATION

The measuring equipment utilized to perform the tests documented in this report has been calibrated in accordance with the manufacturer's recommendations, and is traceable to recognized national standards.

### 4.2. MEASUREMENT UNCERTAINTY

Where relevant, the following measurement uncertainty levels have been estimated for tests performed on the apparatus:

| PARAMETER                           | UNCERTAINTY    |
|-------------------------------------|----------------|
| Radiated Emission, 30 to 200 MHz    | +/- 3.3 dB     |
| Radiated Emission, 200 to 1000 MHz  | +4.5 / -2.9 dB |
| Radiated Emission, 1000 to 2000 MHz | +4.5 / -2.9 dB |
| Power Line Conducted Emission       | +/- 2.9 dB     |

Uncertainty figures are valid to a confidence level of 95%.

## 5. DYNAMIC FREQUENCY SELECTION

### 5.1. OVERVIEW

#### 5.1.1. LIMITS

#### 5.1.2. §15.407 (h) and FCC 06-96 APPENDIX “COMPLIANCE MEASUREMENT PROCEDURES FOR LIMITS

§15.407 (h) and FCC 06-96 APPENDIX “COMPLIANCE MEASUREMENT PROCEDURES FOR UNLICENSED-NATIONAL INFORMATION INFRASTRUCTURE DEVICES OPERATING IN THE 5250-5350 MHz AND 5470-5725 MHz BANDS INCORPORATING DYNAMIC FREQUENCY SELECTION”.

RSS-210 Issue 7 A9.4 Dynamic Frequency Selection (DFS) for devices operating in the 5250-5350 MHz and 5470-5725 MHz bands

RSS-210 is closely harmonized with FCC Part 15 DFS rules. The deviations are as follows:

A9.4 (b) (iv) Channel closing time: the maximum channel closing time is 260 ms.

**Table 1: Applicability of DFS Requirements Prior to Use of a Channel**

| Requirement                            | Operational Mode |                                  |                               |
|--|------------------|----------------------------------|-------------------------------|
|  | Master           | Client (without radar detection) | Client (with radar detection) |
| <i>Non-Occupancy Period</i>            | Yes              | Not required                     | Yes                           |
| <i>DFS Detection Threshold</i>         | Yes              | Not required                     | Yes                           |
| <i>Channel Availability Check Time</i> | Yes              | Not required                     | Not required                  |
| <i>Uniform Spreading</i>               | Yes              | Not required                     | Not required                  |

**Table 2: Applicability of DFS Requirements During Normal Operation**

| Requirement                              | Operational Mode |                      |                   |
|--|------------------|----------------------|-------------------|
|  | Master           | Client (without DFS) | Client (with DFS) |
| <i>DFS Detection Threshold</i>           | Yes              | Not required         | Yes               |
| <i>Channel Closing Transmission Time</i> | Yes              | Yes                  | Yes               |
| <i>Channel Move Time</i>                 | Yes              | Yes                  | Yes               |
| <i>U-NII Detection Bandwidth</i>         | Yes              | Not required         | Yes               |

**Table 3: DFS Detection Thresholds for Master Devices and Client Devices with Radar Detection**

| Maximum Transmit Power | Value<br>(see note) |
|------------------------|---------------------|
| ≥ 200 milliwatt        | -64 dBm             |
| < 200 milliwatt        | -62 dBm             |

Note 1: This is the level at the input of the receiver assuming a 0 dBi receive antenna.  
 Note 2: Throughout these test procedures an additional 1 dB has been added to the amplitude of the test transmission waveforms to account for variations in measurement equipment. This will ensure that the test signal is at or above the detection threshold level to trigger a DFS response.

**Table 4: DFS Response Requirement Values**

| Parameter                                | Value  |
|--|--|
| <i>Non-occupancy period</i>              | Minimum 30 minutes   |
| <i>Channel Availability Check Time</i>   | 60 seconds   |
| <i>Channel Move Time</i>                 | 10 seconds See Note 1.   |
| <i>Channel Closing Transmission Time</i> | 200 milliseconds + an aggregate of 60 milliseconds over remaining 10 second period. See Notes 1 and 2. |
| <i>U-NII Detection Bandwidth</i>         | Minimum 80% of the UNII 99% transmission power bandwidth. See Note 3.                                  |

**Note 1:** The instant that the *Channel Move Time* and the *Channel Closing Transmission Time* begins is as follows:

- For the Short pulse radar Test Signals this instant is the end of the *Burst*.
- For the Frequency Hopping radar Test Signal, this instant is the end of the last radar *Burst* generated.
- For the Long Pulse radar Test Signal this instant is the end of the 12 second period defining the *Radar Waveform*.

**Note 2:** The *Channel Closing Transmission Time* is comprised of 200 milliseconds starting at the beginning of the *Channel Move Time* plus any additional intermittent control signals required to facilitate a *Channel* move (an aggregate of 60 milliseconds) during the remainder of the 10 second period. The aggregate duration of control signals will not count quiet periods in between transmissions.

**Note 3:** During the *U-NII Detection Bandwidth* detection test, radar type 1 is used and for each frequency step the minimum percentage of detection is 90 percent. Measurements are performed with no data traffic.

**Table 5 – Short Pulse Radar Test Waveforms**

| Radar Type                  | Pulse Width (μsec) | PRI (μsec) | Number of Pulses | Minimum Percentage of Successful Detection | Minimum Number of Trials |
|-----------------------------|--------------------|------------|------------------|--|--------------------------|
| 1                           | 1                  | 1428       | 18               | 60%  | 30                       |
| 2                           | 1-5                | 150-230    | 23-29            | 60%  | 30                       |
| 3                           | 6-10               | 200-500    | 16-18            | 60%  | 30                       |
| 4                           | 11-20              | 200-500    | 12-16            | 60%  | 30                       |
| Aggregate (Radar Types 1-4) |                    |            |                  | 80%  | 120                      |

**Table 6 – Long Pulse Radar Test Signal**

| Radar Type | Bursts | Pulses per Burst | Pulse Width (μsec) | Chirp Width (MHz) | PRI (μsec) | Minimum Percentage of Successful Detection | Minimum Number of Trials |
|------------|--------|------------------|--------------------|-------------------|------------|--|--------------------------|
| 5          | 8-20   | 1-3              | 50-100             | 5-20              | 1000-2000  | 80%  | 30                       |

**Table 7 – Frequency Hopping Radar Test Signal**

| Radar Type | Pulse Width (μsec) | PRI (μsec) | Burst Length (msec) | Pulses per Hop | Hopping Rate (kHz) | Minimum Percentage of Successful Detection | Minimum Number of Trials |
|------------|--------------------|------------|---------------------|----------------|--------------------|--|--------------------------|
| 6          | 1                  | 333        | 300                 | 9              | 0.333              | 70%  | 30                       |



### 5.1.3. TEST AND MEASUREMENT SYSTEM

#### CONDUCTED METHOD SYSTEM BLOCK DIAGRAM

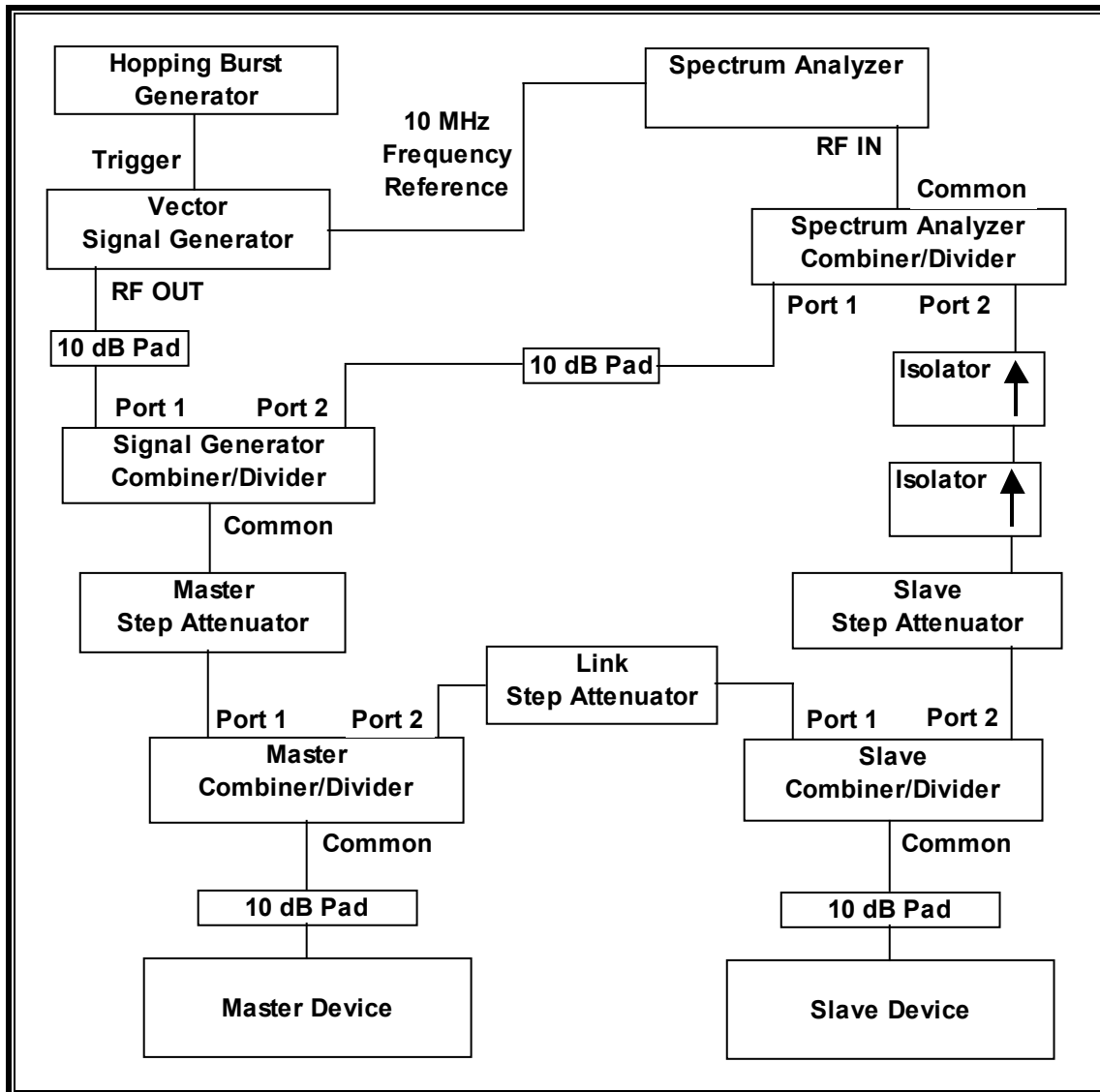

## **SYSTEM OVERVIEW**

The short pulse and long pulse signal generating system utilizes the NTIA software. The Vector Signal Generator has been validated by the NTIA. The hopping signal generating system utilizes the CCS simulated hopping method and system, which has been validated by the DoD, FCC and NTIA. The software selects waveform parameters from within the bounds of the signal type on a random basis using uniform distribution.

The short pulse types 2, 3 and 4, and the long pulse type 5 parameters are randomized at run-time.

The hopping type 6 pulse parameters are fixed while the hopping sequence is based on the August 2005 NTIA Hopping Frequency List. The initial starting point randomized at run-time and each subsequent starting point is incremented by 475. Each frequency in the 100-length segment is compared to the boundaries of the EUT Detection Bandwidth and the software creates a hopping burst pattern in accordance with Section 7.4.1.3 Method #2 Simulated Frequency Hopping Radar Waveform Generating Subsystem of FCC 06-96 APPENDIX. The frequency of the signal generator is incremented in 1 MHz steps from  $F_L$  to  $F_H$  for each successive trial. This incremental sequence is repeated as required to generate a minimum of 30 total trials and to maintain a uniform frequency distribution over the entire Detection Bandwidth.

The signal monitoring equipment consists of a spectrum analyzer set to display 8001 bins on the horizontal axis. The time-domain resolution is 2 msec / bin with a 16 second sweep time, meeting the 10 second short pulse reporting criteria. The aggregate ON time is calculated by multiplying the number of bins above a threshold during a particular observation period by the dwell time per bin, with the analyzer set to peak detection and max hold.

Should multiple RF ports be utilized for the Master and/or Slave devices (for example, for diversity or MIMO implementations), additional combiner/dividers are inserted between the Master Combiner/Divider and the pad connected to the Master Device (and/or between the Slave Combiner/Divider and the pad connected to the Slave Device). Additional pads are utilized such that there is one pad at each RF port on each EUT.

## **SYSTEM CALIBRATION**

A 50 ohm load is connected in place of the spectrum analyzer, and the spectrum analyzer is connected in place of the master device and the signal generator is set to CW mode. The amplitude of the signal generator is adjusted to yield a level of -64 dBm as measured on the spectrum analyzer.

Without changing any of the instrument settings, the spectrum analyzer is reconnected to the Common port of the Spectrum Analyzer Combiner/Divider. Measure the amplitude and calculate the difference from -64 dBm. Adjust the Reference Level Offset of the spectrum analyzer to this difference.

The spectrum analyzer displays the level of the signal generator as received at the antenna ports of the Master Device. The interference detection threshold may be varied from the calibrated value of -64 dBm and the spectrum analyzer will still indicate the level as received by the Master Device.

Set the signal generator to produce a radar waveform, trigger a burst manually and measure the level on the spectrum analyzer. Readjust the amplitude of the signal generator as required so that the peak level of the waveform is at a displayed level equal to the required or desired interference detection threshold. Separate signal generator amplitude settings are determined as required for each radar type.

### **ADJUSTMENT OF DISPLAYED TRAFFIC LEVEL**

Establish a link between the Master and Slave, adjusting the Link Step Attenuator as needed to provide a suitable received level at the Master and Slave devices. Stream the video test file to generate WLAN traffic. Confirm that the WLAN traffic level, as displayed on the spectrum analyzer, is at lower amplitude than the radar detection threshold. For Master Device testing confirm that the displayed traffic does not include Slave Device traffic. For Slave Device testing confirm that the displayed traffic does not include Master Device traffic.

If a different setting of the Master Step Attenuator is required to meet the above conditions, perform a new System Calibration for the new Master Step Attenuator setting.

### **TEST AND MEASUREMENT EQUIPMENT**

The following test and measurement equipment was utilized for the DFS tests documented in this report:

| <b>TEST EQUIPMENT LIST</b>           |                      |              |                      |                |
|--------------------------------------|----------------------|--------------|----------------------|----------------|
| <b>Description</b>                   | <b>Manufacturer</b>  | <b>Model</b> | <b>Serial Number</b> | <b>Cal Due</b> |
| Spectrum Analyzer 3 Hz ~ 44 GHz      | Agilent / HP         | E4446A       | US42070220           | 7/29/2007      |
| Vector Signal Generator 250kHz-20GHz | Agilent / HP         | E8267C       | US43320336           | 11/2/2007      |
| High Speed Digital I/O Card          | National Instruments | PCI-6534     | HA1612845            | 1/16/2008      |

**CONDUCTED METHOD EUT TEST SETUP**

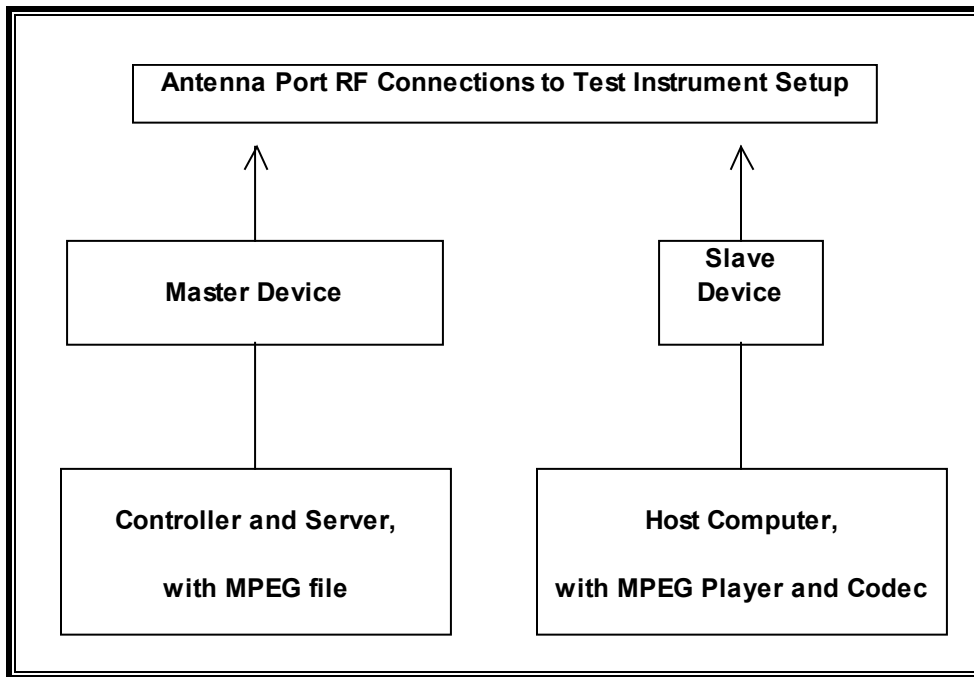

**SUPPORT EQUIPMENT**

The following test and measurement equipment was utilized for the 20 MHz bandwidth DFS tests documented in this report:

| PERIPHERAL SUPPORT EQUIPMENT LIST |              |                    |                          |           |
|-----------------------------------|--------------|--------------------|--------------------------|-----------|
| Description                       | Manufacturer | Model              | Serial Number            | FCC ID    |
| Laptop                            | DELL         | Dell Inspiron 4150 | CN-04P449-48643-2CH-2011 | DoC       |
| AC Adapter                        | DELL         | ADP-70EB           | TH-09364U-17971-248-8PDP | DoC       |
| Laptop                            | Compaq       | Presario 3000      | CNU327025L               | DoC       |
| AC Adapter                        | Compaq       | PA-1900-05H        | 3300371601               | DoC       |
| Access Point                      | CISCO        | AIR-API242AG-A-K9  | FTX1042B5E0              | LDK102056 |
| AC Adapter                        | Delta        | ADP-18PB           | PZT0628359656            | DoC       |

The following test and measurement equipment was utilized for the 40 MHz bandwidth DFS tests documented in this report:

| PERIPHERAL SUPPORT EQUIPMENT LIST |              |                    |                          |              |
|-----------------------------------|--------------|--------------------|--------------------------|--------------|
| Description                       | Manufacturer | Model              | Serial Number            | FCC ID       |
| Laptop                            | HP           | PA-1121-12HD       | PPP017L                  | DoC          |
| AC Adapter                        | HP           | HP Pavilion zv6000 | CND52904s1               | DoC          |
| Laptop                            | DELL         | ADP-70EB           | TH-09364U-17971-248-8PDP | DoC          |
| AC Adapter                        | DELL         | Dell Inspiron 4150 | CN-04P449-48643-2CH-2011 | DoC          |
| Access Point                      | Broadcom     | BCM94705LMP        | Prototype                | QDS-BRCM1025 |
| AC Adapter                        | Bothhand     | M1-10S05           | R00031106975B            | DoC          |

#### **5.1.4. DESCRIPTION OF EUT WITH RESPECT TO FCC 06-96 REQUIREMENTS**

The EUT operates over the 5250-5350 MHz range with a carrier tuning range of 5260 – 5320 MHz, and over the 5470-5725 MHz range with a carrier tuning range of 5500 – 5700 MHz.

The EUT is a Slave Device without radar detection.

The transmit conducted output power for for the 5250-5350 MHz band and 5470-5725 MHz band is covered in the RF Emissions Report.

The main antenna assembly utilized with the EUT has a gain of 1.2 dBi for the 5250-5350 MHz band and 1.2 dBi in the 5470-5725 MHz band. The aux antenna assembly utilized with the EUT has a gain of 1.2 dBi for the 5250-5350 MHz band and 1.2 dBi in the 5470-5725 MHz band.

All antennas are integral.

Two non-identical antennas are utilized to meet the MIMO transmit diversity operational requirements.

The EUT uses two transmitters, each connected to a 50-ohm coaxial antenna port. Both antenna ports are connected to the test system via a power divider to perform conducted tests.

WLAN traffic is generated by streaming the video file TestFile.mp2 “6 ½ Magic Hours” from the Master to the Slave in full motion video mode using the media player with the V2.61 Codec package.

TPC is not required since the maximum EIRP is less than 500 mW (27 dBm).

The EUT utilizes the 802.11a/n architecture with 20 MHz and 40 MHz nominal channel bandwidths.

## 5.2. RESULTS FOR 20 MHz BANDWIDTH CONFIGURATION

### 5.2.1. TEST CHANNEL AND METHOD

All tests were performed at a channel center frequency of 5300 MHz. Measurements were performed using conducted test methods.

### 5.2.2. PLOTS OF RADAR WAVEFORM, AND WLAN TRAFFIC

#### PLOTS OF RADAR WAVEFORMS

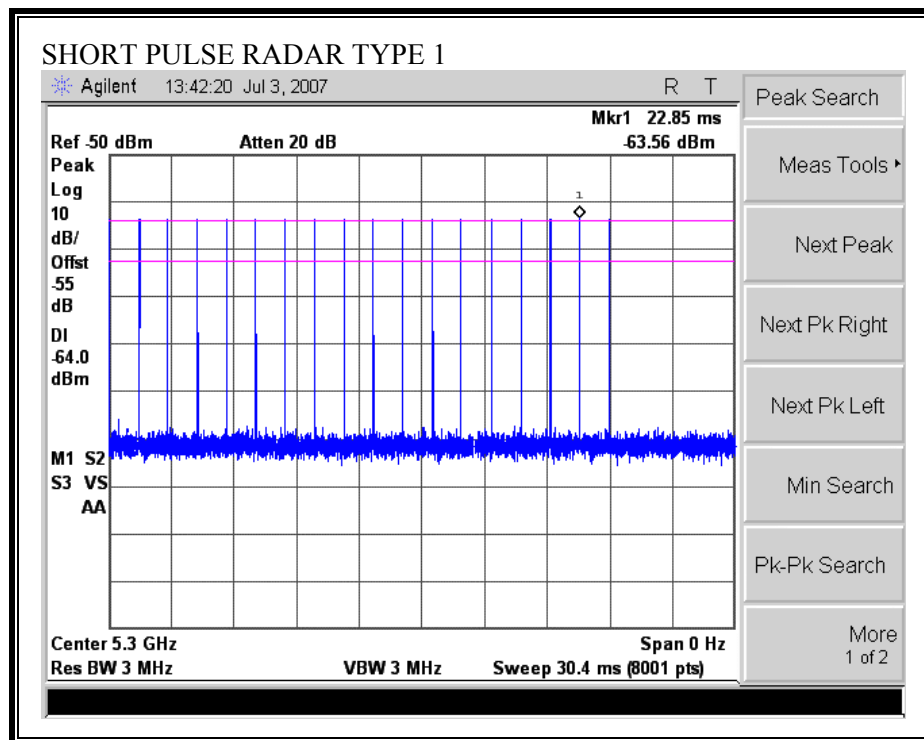

**PLOT OF WLAN TRAFFIC FROM SLAVE**

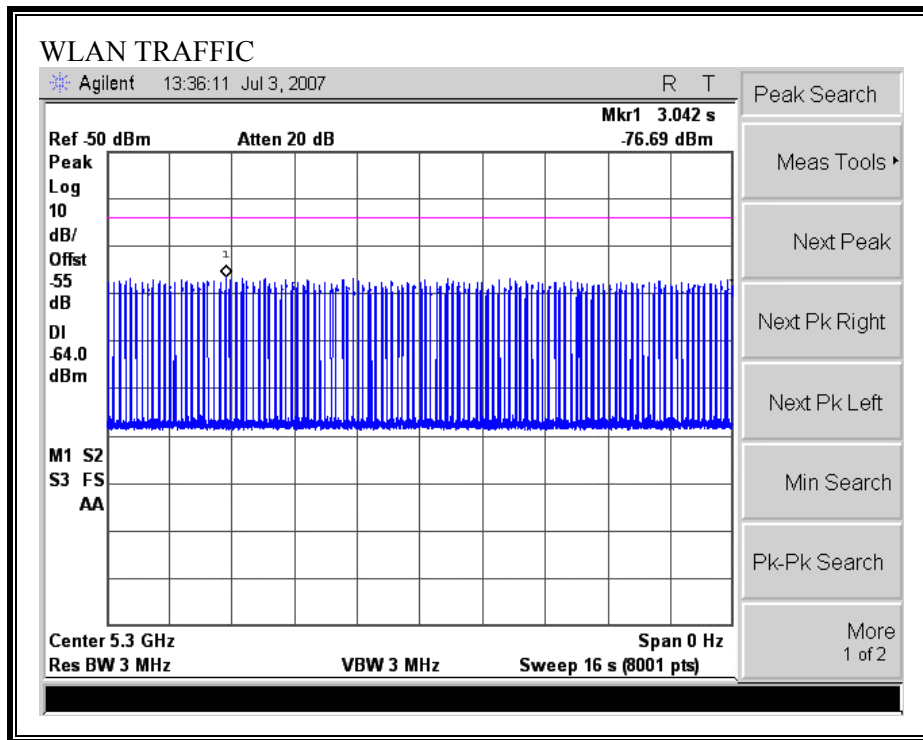



### 5.2.3. MOVE TIME AND CHANNEL CLOSING TRANSMISSION TIME

#### REPORTING NOTES

The reference marker is set at the end of last radar pulse.

The delta marker is set at the end of the last WLAN transmission following the radar pulse. This delta is the channel move time.

The aggregate channel closing transmission time is calculated as follows:

Aggregate Transmission Time =  
(Number of analyzer bins showing transmission) \* (dwell time per bin)

#### FCC

The observation period over which the aggregate time is calculated  
Begins at (Reference Marker + 200 msec)  
and  
Ends no earlier than (Reference Marker + 10 sec).

#### IC

The observation period over which the aggregate time is calculated  
Begins at (Reference Marker)  
and  
Ends no earlier than (Reference Marker + 10 sec).

**CHANNEL MOVE TIME RESULTS**

No non-compliance noted:

| Channel Move Time (s) | Limit (s) |
|-----------------------|-----------|
| 0.090                 | 10        |

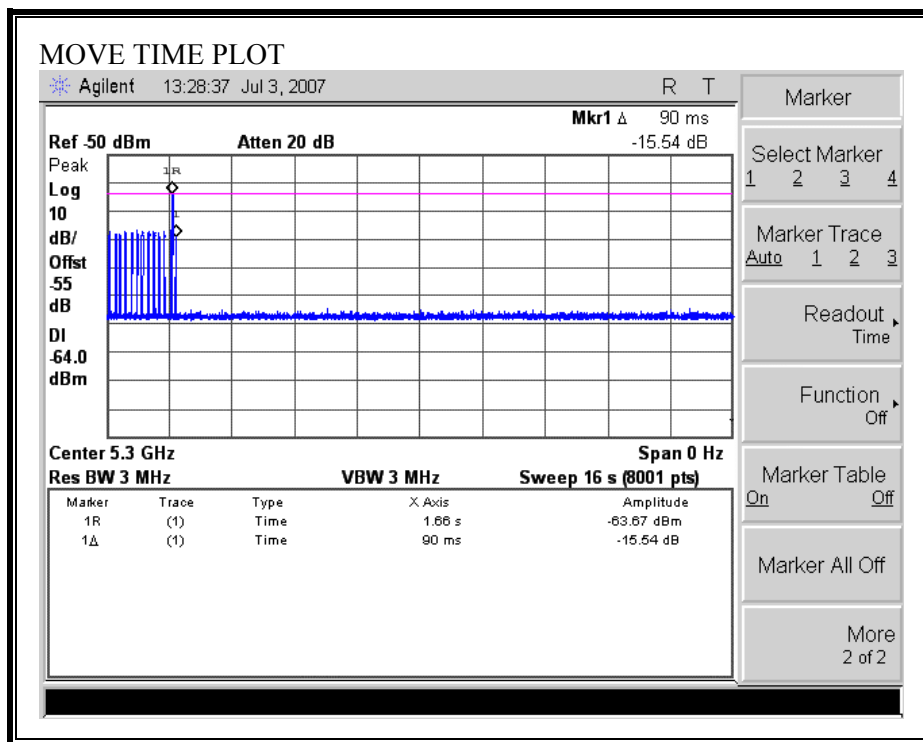

**CHANNEL CLOSING TIME RESULTS**

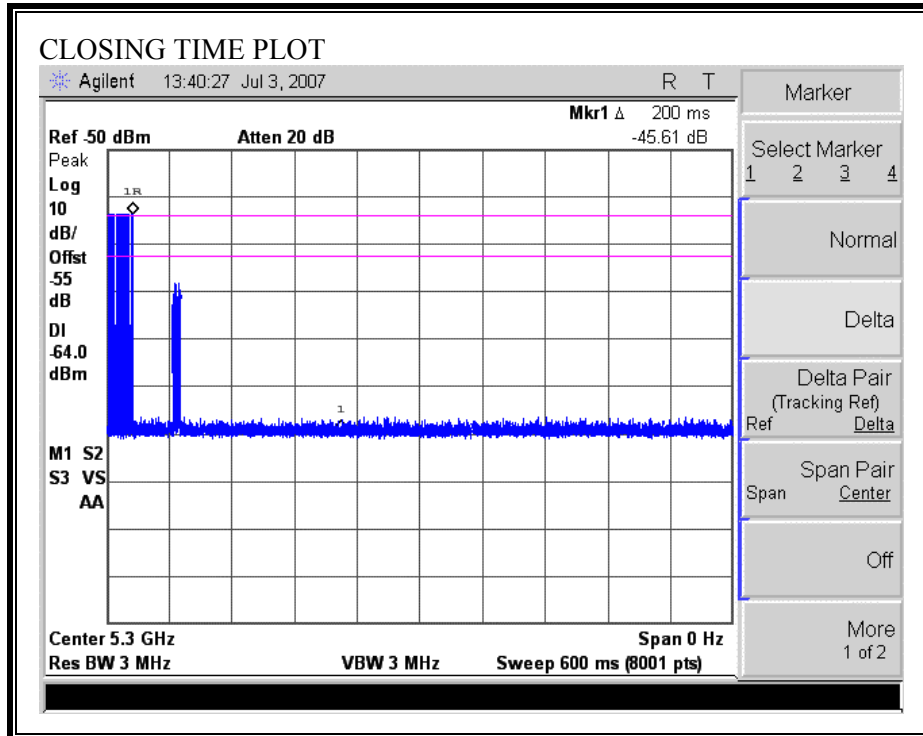

**FCC AGGREGATE CHANNEL CLOSING TRANSMISSION TIME RESULTS**

No non-compliance noted:

| Aggregate Transmission Time (ms) | Limit (ms) | Margin (ms) |
|----------------------------------|------------|-------------|
| 0.00                             | 60         | 60.00       |

No transmissions are observed during the aggregate monitoring period.

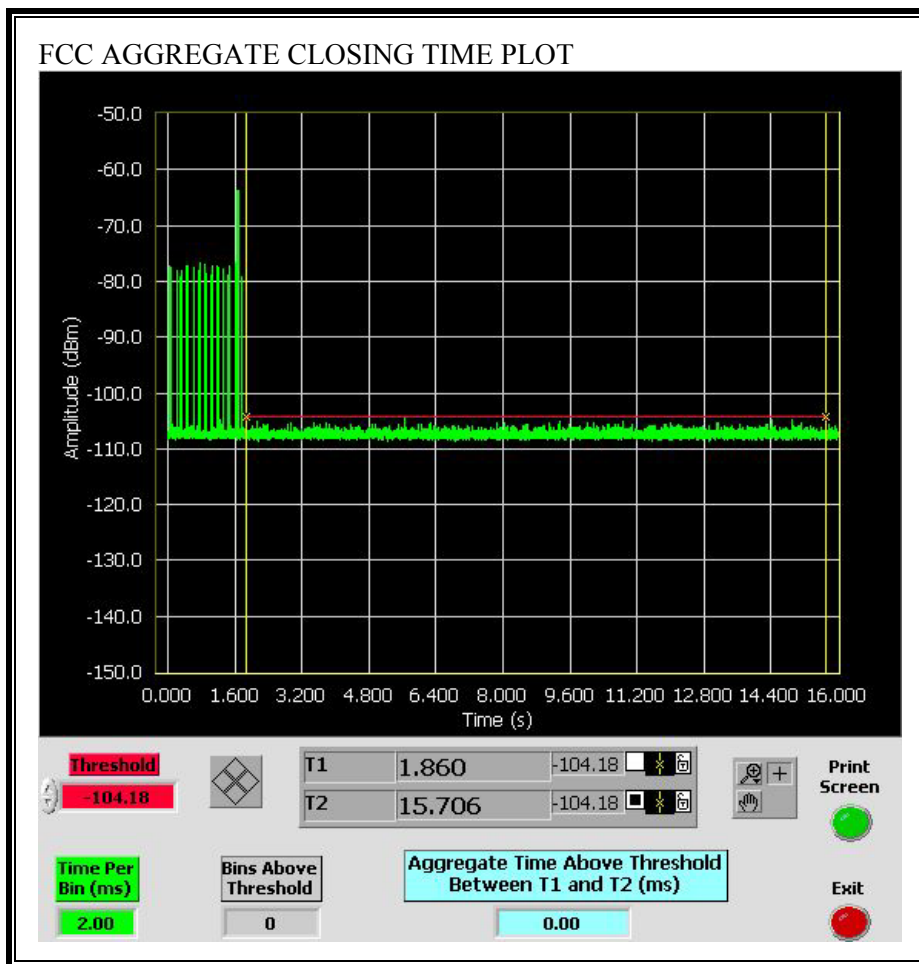

**IC AGGREGATE CHANNEL CLOSING TRANSMISSION TIME RESULTS**

No non-compliance noted:

| Aggregate Transmission Time (ms) | Limit (ms) | Margin (ms) |
|----------------------------------|------------|-------------|
| 18.00                            | 260        | 242.00      |

Only intermittent transmissions are observed during the aggregate monitoring period.

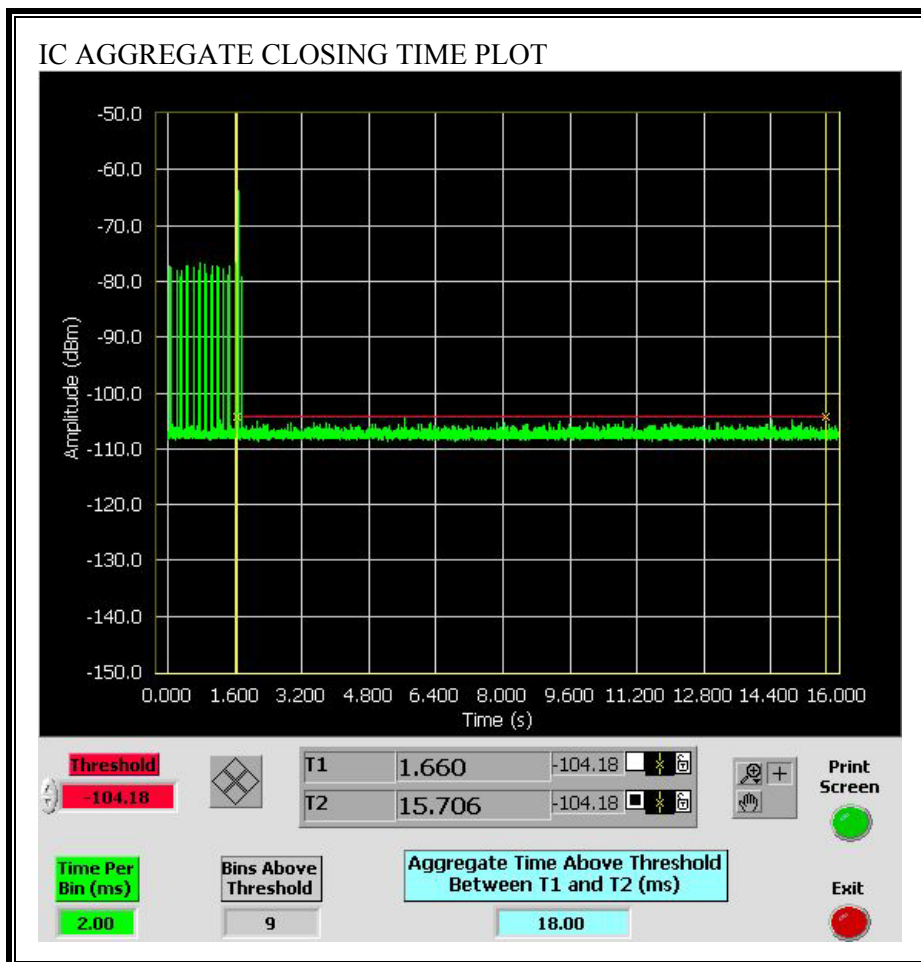

### 5.3. RESULTS FOR 40 MHz BANDWIDTH CONFIGURATION

#### 5.3.1. TEST CHANNEL AND METHOD

All tests were performed at a channel center frequency of 5310 MHz. Measurements were performed using conducted test methods.

#### 5.3.2. PLOTS OF RADAR WAVEFORM, AND WLAN TRAFFIC

##### PLOTS OF RADAR WAVEFORMS

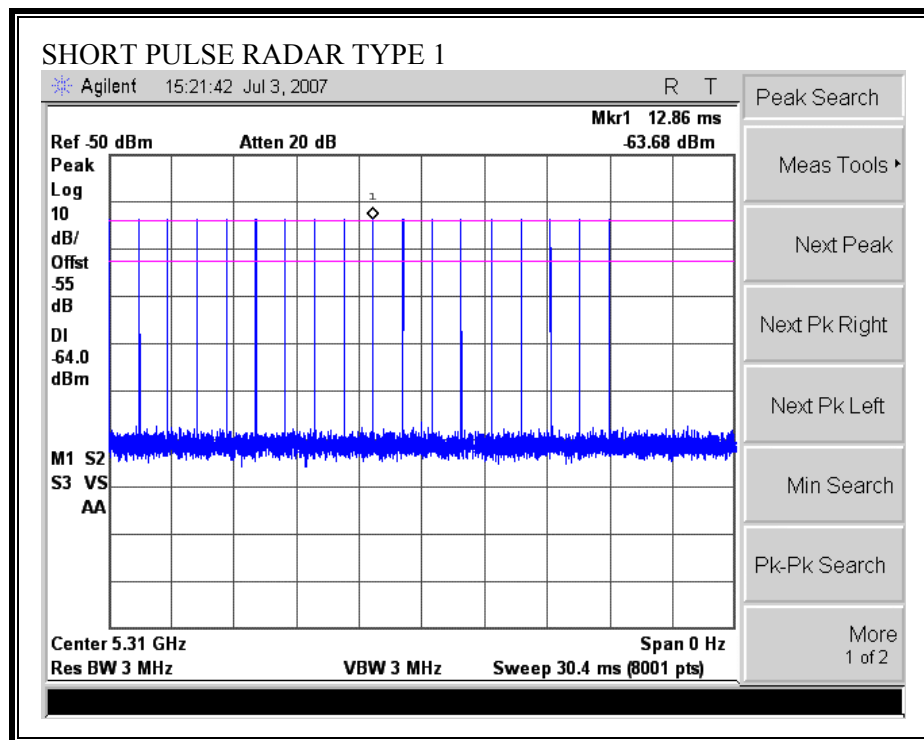

**PLOT OF WLAN TRAFFIC FROM SLAVE**

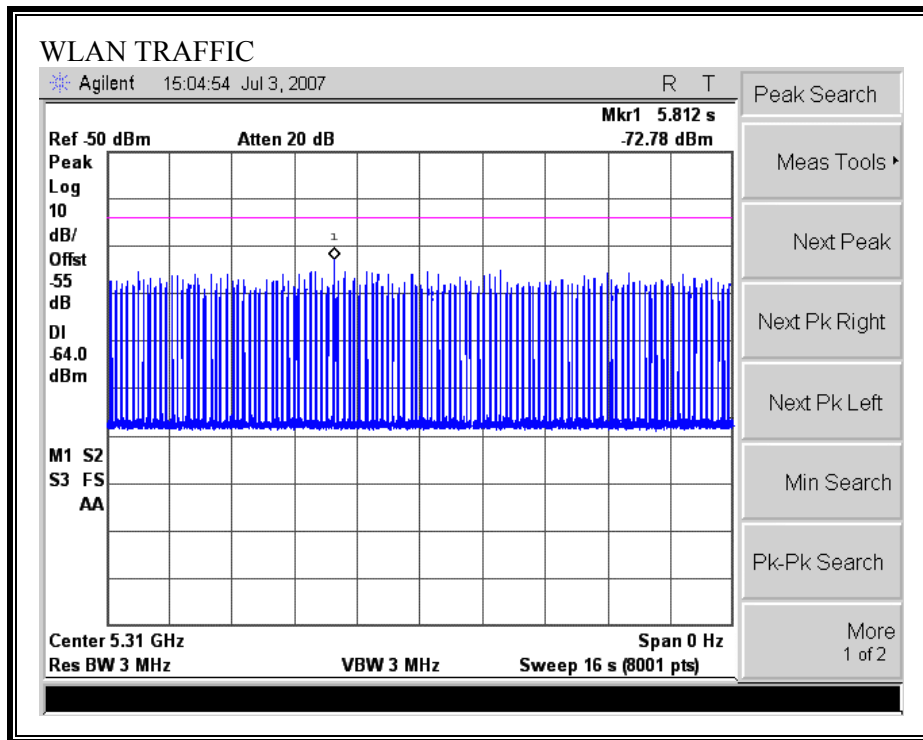

### **5.3.3. CHANNEL MOVE TIME AND CHANNEL CLOSING TRANSMISSION TIME**

#### **REPORTING NOTES**

The reference marker is set at the end of last radar pulse.

The delta marker is set at the end of the last WLAN transmission following the radar pulse. This delta is the channel move time.

The aggregate channel closing transmission time is calculated as follows:

Aggregate Transmission Time =  
(Number of analyzer bins showing transmission) \* (dwell time per bin)

FCC

The observation period over which the aggregate time is calculated  
Begins at (Reference Marker + 200 msec)  
and  
Ends no earlier than (Reference Marker + 10 sec).

IC

The observation period over which the aggregate time is calculated  
Begins at (Reference Marker)  
and  
Ends no earlier than (Reference Marker + 10 sec).



**CHANNEL MOVE TIME RESULTS**

No non-compliance noted:

| Channel Move Time (s) | Limit (s) |
|-----------------------|-----------|
| 0.152                 | 10        |

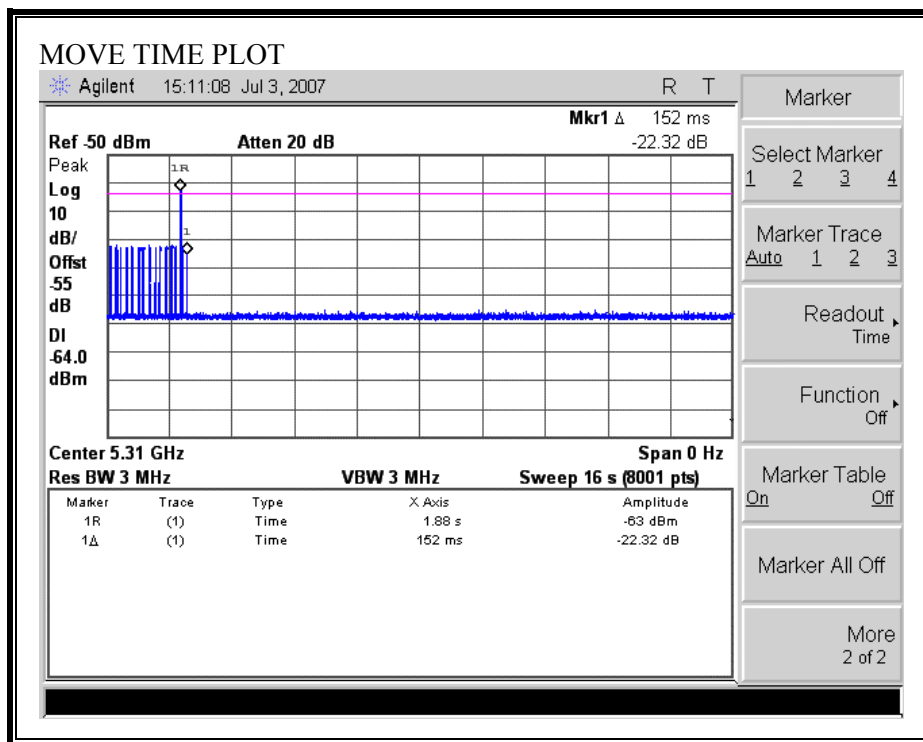

**CHANNEL CLOSING TIME RESULTS**

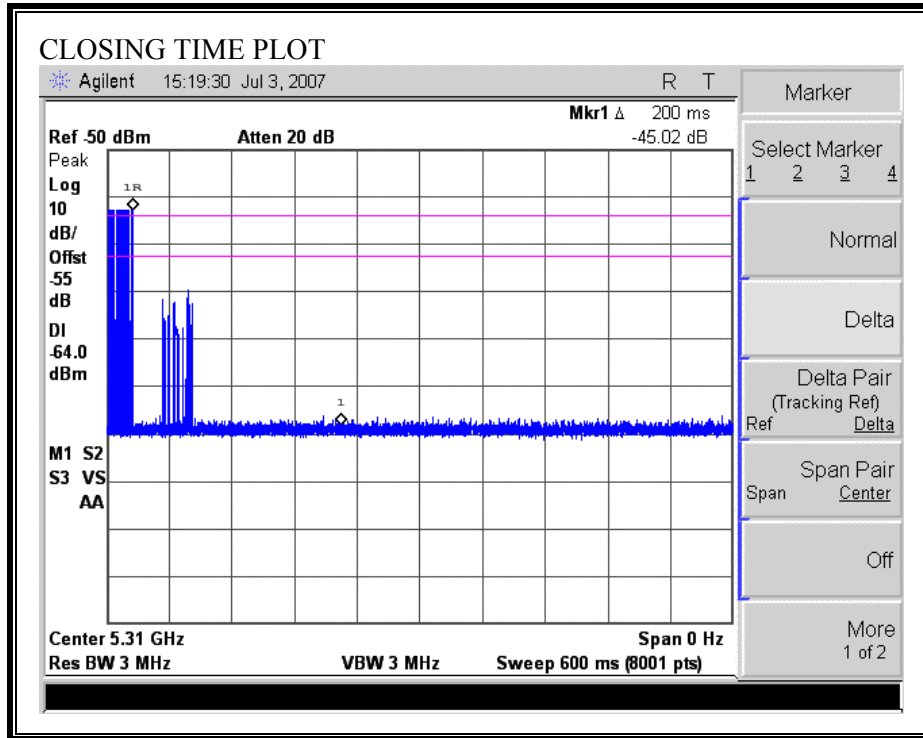

**FCC AGGREGATE CHANNEL CLOSING TRANSMISSION TIME RESULTS**

No non-compliance noted:

| Aggregate Transmission Time (ms) | Limit (ms) | Margin (ms) |
|----------------------------------|------------|-------------|
| 0.00                             | 60         | 60.00       |

No transmissions are observed during the aggregate monitoring period.

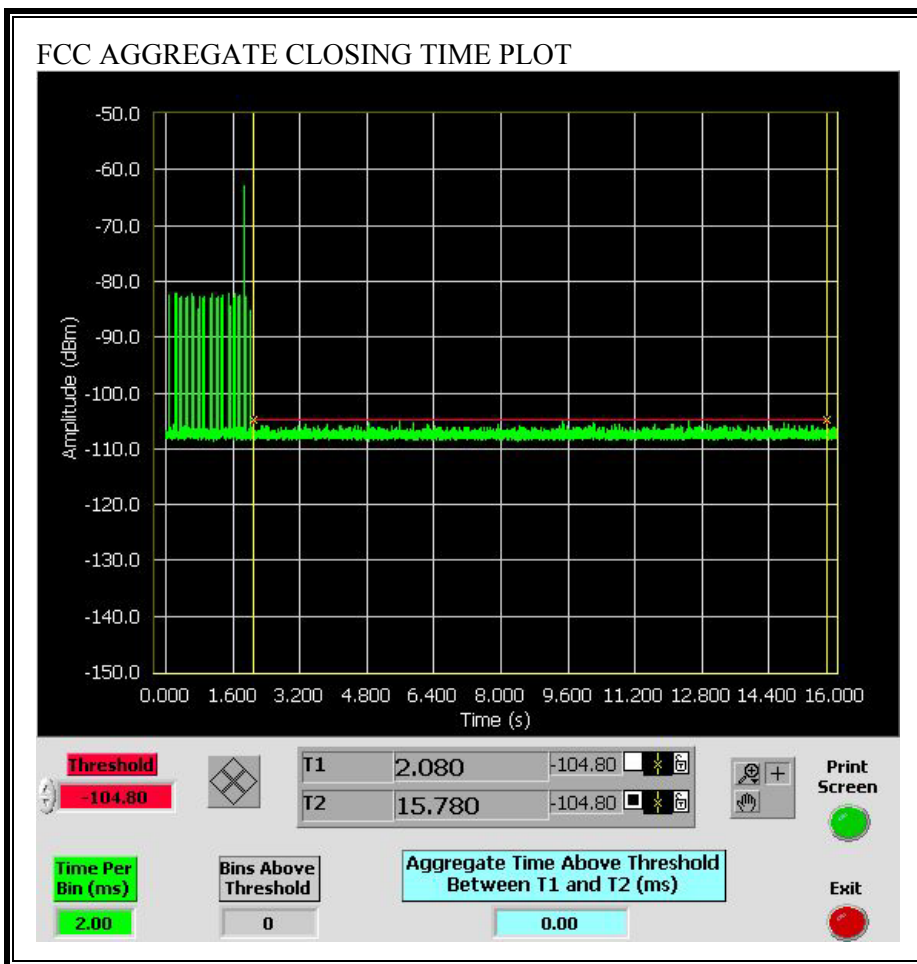

**IC AGGREGATE CHANNEL CLOSING TRANSMISSION TIME RESULTS**

No non-compliance noted:

| Aggregate Transmission Time (ms) | Limit (ms) | Margin (ms) |
|----------------------------------|------------|-------------|
| 36.00                            | 260        | 224.00      |

Only intermittent transmissions are observed during the aggregate monitoring period.

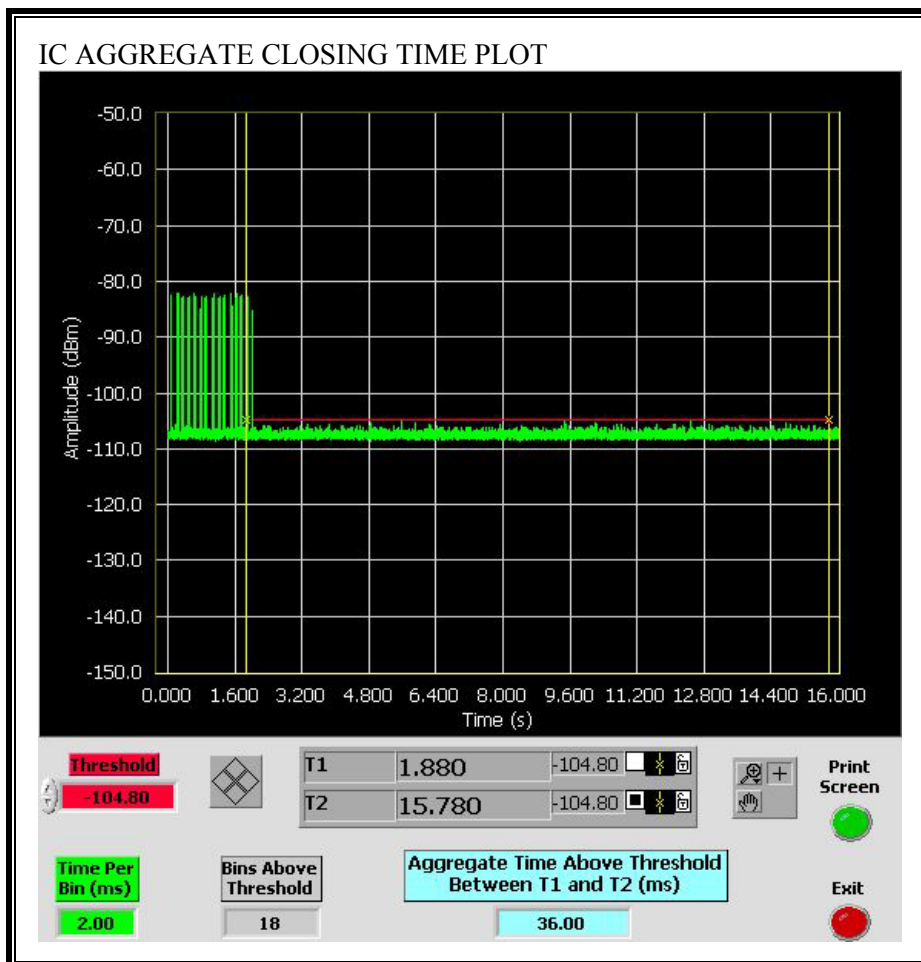

## 6. SETUP PHOTOS

### 20MHz DFS MEASUREMENT SETUP

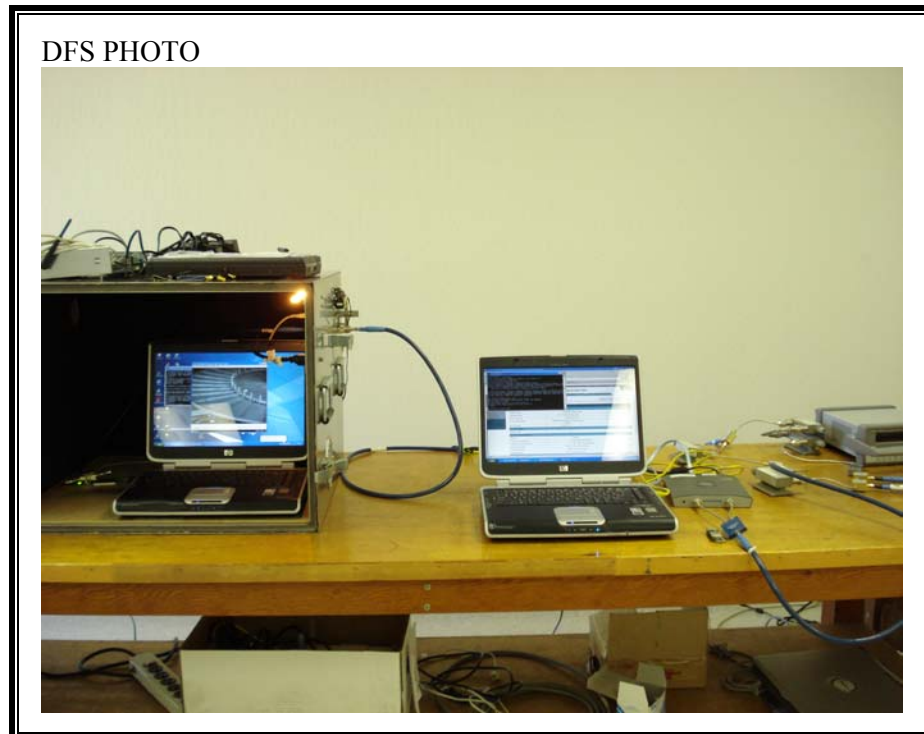

**40MHz DFS MEASUREMENT SETUP**

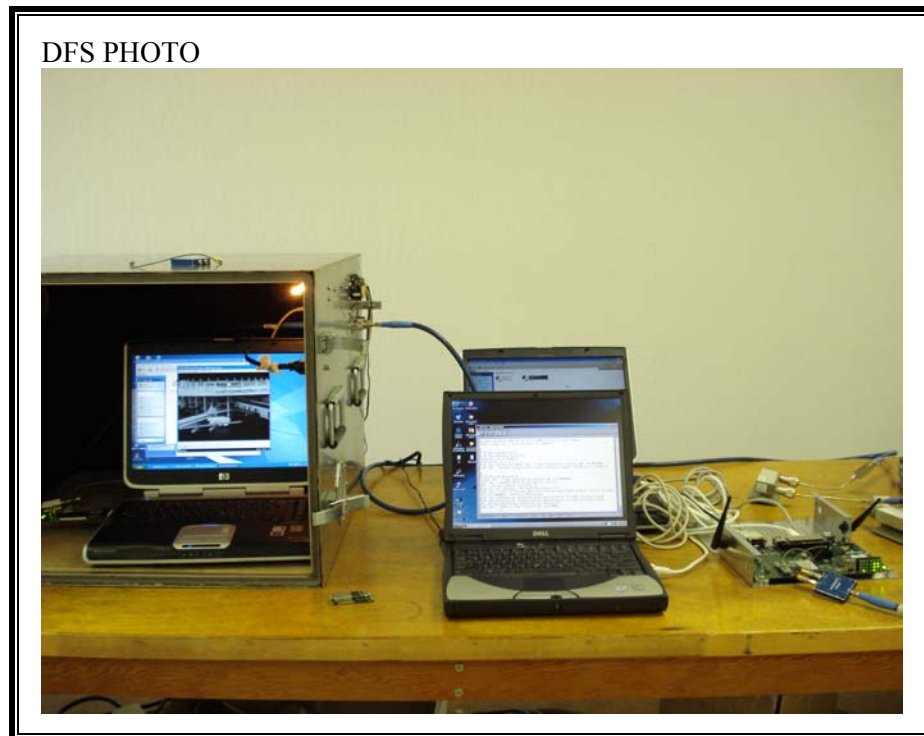

**END OF REPORT**