



# FCC TEST REPORT

**REPORT NO.:** RF950420H04

**MODEL NO.:** WPC300N V1

**RECEIVED:** April 20, 2006

**TESTED:** April 20 to 21, 2006

**ISSUED:** April 24, 2006

**APPLICANT:** Cisco-Linksys LLC

**ADDRESS:** 121 Theory Drive Irvine, CA 92617(USA)

**ISSUED BY:** Advance Data Technology Corporation

**LAB LOCATION:** No. 81-1, Lu Liao Keng, 9 Ling, Wu Lung Tsuen,  
Chiung Lin Hsiang, Hsin Chu Hsien,  
Taiwan, R.O.C.

This test report consists of 114 pages in total. It may be duplicated completely for legal use with the approval of the applicant. It should not be reproduced except in full, without the written approval of our laboratory. The client should not use it to claim product endorsement by CNLA, A2LA or any government agencies. The test results in the report only apply to the tested sample. The test results in this report are traceable to the national or international standards.



No. 2177-01

## TABLE OF CONTENTS

1.	CERTIFICATION.....	4
2.	SUMMARY OF TEST RESULTS .....	5
2.1	MEASUREMENT UNCERTAINTY .....	6
3.	GENERAL INFORMATION.....	7
3.1	GENERAL DESCRIPTION OF EUT .....	7
3.2	DESCRIPTION OF TEST MODES .....	8
3.2.1	TEST MODE APPLICABILITY AND TESTED CHANNEL DETAIL.....	9
3.3	GENERAL DESCRIPTION OF APPLIED STANDARDS.....	13
3.4	DESCRIPTION OF SUPPORT UNITS .....	14
3.5	CONFIGURATION OF SYSTEM UNDER TEST.....	15
4.	TEST TYPES AND RESULTS .....	16
4.1	CONDUCTED EMISSION MEASUREMENT.....	16
4.1.1	LIMITS OF CONDUCTED EMISSION MEASUREMENT .....	16
4.1.2	TEST INSTRUMENTS.....	16
4.1.3	TEST PROCEDURES .....	17
4.1.4	DEVIATION FROM TEST STANDARD.....	17
4.1.5	TEST SETUP.....	18
4.1.6	EUT OPERATING CONDITIONS .....	18
4.1.7	TEST RESULTS .....	19
4.2	RADIATED EMISSION MEASUREMENT.....	25
4.2.1	LIMITS OF RADIATED EMISSION MEASUREMENT .....	25
4.2.2	TEST INSTRUMENTS.....	26
4.2.3	TEST PROCEDURES .....	27
4.2.4	DEVIATION FROM TEST STANDARD.....	27
4.2.5	TEST SETUP.....	28
4.2.6	EUT OPERATING CONDITIONS .....	28
4.2.7	TEST RESULTS .....	29
4.3	6dB BANDWIDTH MEASUREMENT.....	64
4.3.1	LIMITS OF 6DB BANDWIDTH MEASUREMENT.....	64
4.3.2	TEST INSTRUMENTS.....	64
4.3.3	TEST PROCEDURE.....	64
4.3.4	DEVIATION FROM TEST STANDARD.....	64
4.3.5	TEST SETUP.....	65
4.3.6	EUT OPERATING CONDITIONS .....	65



4.3.7	TEST RESULTS .....	66
4.4	MAXIMUM PEAK OUTPUT POWER.....	78
4.4.1	LIMITS OF MAXIMUM PEAK OUTPUT POWER MEASUREMENT.....	78
4.4.2	INSTRUMENTS .....	78
4.4.3	TEST PROCEDURES .....	78
4.4.4	DEVIATION FROM TEST STANDARD.....	78
4.4.5	TEST SETUP.....	79
4.4.6	EUT OPERATING CONDITIONS .....	79
4.4.7	TEST RESULTS .....	80
4.5	POWER SPECTRAL DENSITY MEASUREMENT .....	82
4.5.1	LIMITS OF POWER SPECTRAL DENSITY MEASUREMENT .....	82
4.5.2	TEST INSTRUMENTS.....	82
4.5.3	TEST PROCEDURE.....	82
4.5.4	DEVIATION FROM TEST STANDARD.....	82
4.5.5	TEST SETUP.....	83
4.5.6	EUT OPERATING CONDITION.....	83
4.5.7	TEST RESULTS .....	84
4.6	CONDUCTED EMISSION AND BAND EDGES MEASUREMENT .....	96
4.6.1	LIMITS OF CONDUCTED EMISSION AND BAND EDGES MEASUREMENT .....	96
4.6.2	TEST INSTRUMENTS.....	96
4.6.3	TEST PROCEDURE.....	96
4.6.4	DEVIATION FROM TEST STANDARD.....	97
4.6.5	EUT OPERATING CONDITION.....	97
4.6.6	TEST RESULTS .....	97
4.7	ANTENNA REQUIREMENT .....	110
4.7.1	STANDARD APPLICABLE.....	110
4.7.2	ANTENNA CONNECTED CONSTRUCTION .....	110
5.	PHOTOGRAPHS OF THE TEST CONFIGURATION .....	111
6.	INFORMATION ON THE TESTING LABORATORIES.....	113
	APPENDIX-A.....	A-1



# 1. CERTIFICATION

**PRODUCT :** Wireless-N Notebook Adapter  
**MODEL NO.:** WPC300N V1  
**BRAND:** Linksys  
**APPLICANT :** Cisco-Linksys LLC  
**TESTED:** April 20 to 21, 2006  
**TEST SAMPLE:** ENGINEERING SAMPLE  
**STANDARDS :** FCC Part 15, Subpart C (Section 15.247),  
ANSI C63.4-2003

The above equipment (Model: WPC300N V1) has been tested by **Advance Data Technology Corporation**, and found compliance with the requirement of the above standards. The test record, data evaluation & Equipment Under Test (EUT) configurations represented herein are true and accurate accounts of the measurements of the sample's EMC characteristics under the conditions specified in this report.

**PREPARED BY :** Midoli Peng , **DATE:** April 24, 2006  
( Midoli Peng )

**TECHNICAL ACCEPTANCE :** Hank Chung , **DATE:** April 24, 2006  
Responsible for RF ( Hank Chung )

**APPROVED BY :** May Chen , **DATE:** April 24, 2006  
( May Chen, Deputy Manager )

## 2. SUMMARY OF TEST RESULTS

The EUT has been tested according to the following specifications:

APPLIED STANDARD: FCC Part 15, Subpart C			
STANDARD SECTION	TEST TYPE AND LIMIT	RESULT	REMARK
15.207	AC Power Conducted Emission	PASS	Meet the requirement of limit. Minimum passing margin is -19.56dB at 0.154MHz.
15.247(a)(2)	Spectrum Bandwidth of a Direct Sequence Spread Spectrum System Limit : min. 500kHz	PASS	Meet the requirement of limit.
15.247(b)	Maximum Peak Output Power Limit: max. 30dBm	PASS	Meet the requirement of limit.
15.247(d)	Transmitter Radiated Emissions Limit: Table 15.209	PASS	Meet the requirement of limit. Minimum passing margin is -0.3dB at 2387.00MHz
15.247(e)	Power Spectral Density Limit: max. 8dBm	PASS	Meet the requirement of limit.
15.247(d)	Band Edge Measurement Limit: 20dB less than the peak value of fundamental frequency	PASS	Meet the requirement of limit.

## 2.1 MEASUREMENT UNCERTAINTY

Where relevant, the following measurement uncertainty levels have been estimated for tests performed on the EUT as specified in CISPR 16-4:

MEASUREMENT	FREQUENCY	UNCERTAINTY
Conducted emissions	9kHz ~ 30MHz	2.26 dB
Radiated emissions	30MHz ~ 200MHz	3.59 dB
	200MHz ~1000MHz	3.61 dB
	1GHz ~ 18GHz	2.26 dB
	18GHz ~ 40GHz	1.94 dB

This uncertainty represents an expanded uncertainty expressed at approximately the 95% confidence level using a coverage factor of  $k = 2$ .



### 3. GENERAL INFORMATION

#### 3.1 GENERAL DESCRIPTION OF EUT

<b>PRODUCT</b>	Wireless-N Notebook Adapter
<b>MODEL NO.</b>	WPC300N V1
<b>FCC ID</b>	Q87-WPC300NV1
<b>POWER SUPPLY</b>	3.3Vdc from host equipment
<b>MODULATION TYPE</b>	CCK, DQPSK, DBPSK for DSSS 64QAM, 16QAM, QPSK, BPSK for OFDM
<b>MODULATION TECHNOLOGY</b>	DSSS, OFDM
<b>TRANSFER RATE</b>	802.11b: 11/ 5.5/ 2/ 1Mbps 802.11g: 54/ 48/ 36/ 24/ 18/ 12/ 9/ 6Mbps Draft 802.11n (20MHz): 130/117/104/78/65/58.5/52/39/26/19.5/13/6.5Mbps Draft 802.11n (40MHz): 270/ 243/ 216/ 162/135/121.5/108/81/54/40.5/27/13.5Mbps
<b>FREQUENCY RANGE</b>	2412MHz ~ 2462MHz
<b>NUMBER OF CHANNEL</b>	11 for 802.11b, 802.11g, draft 802.11n (20MHz) 7 for draft 802.11n (40MHz)
<b>MAXIMUM OUTPUT POWER</b>	802.11b: 97.724mW 802.11g: 147.571mW draft 802.11n (20MHz): 307.990mW draft 802.11n (40MHz): 236.659mW
<b>ANTENNA TYPE</b>	Printed antenna with 2dBi gain
<b>DATA CABLE</b>	NA
<b>I/O PORTS</b>	NA

**NOTE:**

1. The EUT incorporates a MIMO function with 802.11b, 802.11g, draft 802.11n. Physically, the card provides three completed transmit and three receivers.
2. The EUT is 2 \* 2 spatial MIMO without beam forming function.  
The antenna configurations are three transmitter antennas and three receiver antennas, as there are 3 on board antennas.  
Spatial multiplexing modes for simultaneous transmission using 2 antennas, and for simultaneous receiver using 2 antennas.
3. When the EUT operating in draft 802.11n, the software operation, which is defined by manufacturer, MCS (Modulation and Coding Schemes) from 0 to 15.
4. The EUT complies with draft 802.11n standards and backwards compatible with 802.11b, 802.11g products.
5. The EUT operates in the 2.4GHz frequency spectrum with throughput of up to 270Mbps.
6. The above EUT information was declared by manufacturer and for more detailed features description, please refer to the manufacturer's specifications or user's manual.

**3.2 DESCRIPTION OF TEST MODES**

Eleven channels are provided for 802.11b, 802.11g, draft 802.11n (20MHz):

CHANNEL	FREQUENCY	CHANNEL	FREQUENCY
1	2412MHz	7	2442MHz
2	2417MHz	8	2447MHz
3	2422MHz	9	2452MHz
4	2427MHz	10	2457MHz
5	2432MHz	11	2462MHz
6	2437MHz		

Seven channels are provided for draft 802.11n (40MHz):

CHANNEL	FREQUENCY	CHANNEL	FREQUENCY
1	2422MHz	5	2442MHz
2	2427MHz	6	2447MHz
3	2432MHz	7	2452MHz
4	2437MHz		



### 3.2.1 TEST MODE APPLICABILITY AND TESTED CHANNEL DETAIL

#### COMBINATION MODE:

COMBINATION MODE	OPERATION MODE	ANTENNA 1	ANTENNA 2	ANTENNA 3
A	802.11 b	✓		
B			✓	
C				✓
D	802.11g	✓		
E			✓	
F				✓
G	DRAFT 802.11n(20MHz)	✓	✓	
H			✓	✓
I		✓		✓
J	DRAFT 802.11n(40MHz)	✓	✓	
K			✓	✓
L		✓		✓

Note:

1. The above information was declared by manufacturer and for more detailed features description, please refer to the manufacturer's specifications or user's manual.
2. All of Antennas are printed antenna.
3. From above mode, the different modes was chosen for final test and its data were recorded in this report.
4. All of the modes are different operation mode or antenna combination, we choose the worst mode (decided by pretest) for final test. Mode A,D,I,L, the worst modes, was selected as representative mode for the test.

EUT CONFIGURE MODE	APPLICABLE TO				DESCRIPTION
	PLC	RE < 1G	RE ≥ 1G	APCM	
-	√	√	√	√	-

Where **PLC:** Power Line Conducted Emission

**RE < 1G:** Radiated Emission below 1GHz

**RE ≥ 1G:** Radiated Emission above 1GHz

**APCM:** Antenna Port Conducted Measurement

### **POWER LINE CONDUCTED EMISSION TEST:**

- Pre-Scan has been conducted to determine the worst-case mode from all possible combinations between available modulations, data rates and antenna ports (if EUT with antenna diversity architecture).
- Following channel(s) was (were) selected for the final test as listed below.

MODE	AVAILABLE CHANNEL	TESTED CHANNEL	MODULATION TECHNOLOGY	MODULATION TYPE	DATA RATE (Mbps)	TX CONDITION
802.11g	1 to 11	11	OFDM	BPSK	6	Single
Draft 802.11n (20MHz)	1 to 11	11	OFDM	BPSK	6.5	Dual
Draft 802.11n (40MHz)	1 to 7	7	OFDM	BPSK	13.5	Dual

### **RADIATED EMISSION TEST (BELOW 1 GHz):**

- Pre-Scan has been conducted to determine the worst-case mode from all possible combinations between available modulations, data rates and antenna ports (if EUT with antenna diversity architecture).
- Following channel(s) was (were) selected for the final test as listed below.

MODE	AVAILABLE CHANNEL	TESTED CHANNEL	MODULATION TECHNOLOGY	MODULATION TYPE	DATA RATE (Mbps)	TX CONDITION
802.11g	1 to 11	1	OFDM	BPSK	6	Single
Draft 802.11n (20MHz)	1 to 11	1	OFDM	BPSK	6.5	Dual
Draft 802.11n (40MHz)	1 to 7	1	OFDM	BPSK	13.5	Dual

**RADIATED EMISSION TEST (ABOVE 1 GHz):**

- Pre-Scan has been conducted to determine the worst-case mode from all possible combinations between available modulations, data rates and antenna ports (if EUT with antenna diversity architecture).
- Following channel(s) was (were) selected for the final test as listed below.

MODE	AVAILABLE CHANNEL	TESTED CHANNEL	MODULATION TECHNOLOGY	MODULATION TYPE	DATA RATE (Mbps)	TX CONDITION
802.11b	1 to 11	1, 6, 11	DSSS	DBPSK	1	Single
802.11g	1 to 11	1, 6, 11	OFDM	BPSK	6	Single
Draft 802.11n (20MHz)	1 to 11	1, 6, 11	OFDM	BPSK	6.5	Dual
Draft 802.11n (40MHz)	1 to 7	1, 4, 7	OFDM	BPSK	13.5	Dual

**BANDEDGE MEASUREMENT:**

- Pre-Scan has been conducted to determine the worst-case mode from all possible combinations between available modulations, data rates and antenna ports (if EUT with antenna diversity architecture).
- Following channel(s) was (were) selected for the final test as listed below.

MODE	AVAILABLE CHANNEL	TESTED CHANNEL	MODULATION TECHNOLOGY	MODULATION TYPE	DATA RATE (Mbps)	TX CONDITION
802.11b	1 to 11	1, 11	DSSS	DBPSK	1	Single
802.11g	1 to 11	1, 11	OFDM	BPSK	6	Single
Draft 802.11n (20MHz)	1 to 11	1, 11	OFDM	BPSK	6.5	Dual
Draft 802.11n (40MHz)	1 to 7	1, 7	OFDM	BPSK	13.5	Dual



**ANTENNA PORT CONDUCTED MEASUREMENT:**

- Pre-Scan has been conducted to determine the worst-case mode from all possible combinations between available modulations, data rates and antenna ports (if EUT with antenna diversity architecture).
- Following channel(s) was (were) selected for the final test as listed below.

MODE	AVAILABLE CHANNEL	TESTED CHANNEL	MODULATION TECHNOLOGY	MODULATION TYPE	DATA RATE (Mbps)	TX CONDITION
802.11b	1 to 11	1, 6, 11	DSSS	DBPSK	1	Single
802.11g	1 to 11	1, 6, 11	OFDM	BPSK	6	Single
Draft 802.11n (20MHz)	1 to 11	1, 6, 11	OFDM	BPSK	6.5	Dual
Draft 802.11n (40MHz)	1 to 7	1, 4, 7	OFDM	BPSK	13.5	Dual



### **3.3 GENERAL DESCRIPTION OF APPLIED STANDARDS**

The EUT is a RF product. According to the specifications of the manufacturer, it must comply with the requirements of the following standards:

**FCC Part 15, Subpart C. (15.247)**

**ANSI C63.4-2003**

All test items have been performed and recorded as per the above standards.

**NOTE:** The EUT is also considered as a kind of computer peripheral, because the connection to computer is necessary for typical use. It has been verified to comply with the requirements of FCC Part 15, Subpart B, Class B (DoC). The test report has been issued separately.



### 3.4 DESCRIPTION OF SUPPORT UNITS

The EUT has been tested as an independent unit together with other necessary accessories or support units. The following support units or accessories were used to form a representative test configuration during the tests.

NO.	PRODUCT	BRAND	MODEL NO.	SERIAL NO.	FCC ID
1	NOTEBOOK COMPUTER	DELL	PP05L	CN-04Y212-48643-38E-0145	DoC
2	PRINTER	EPSON	LQ-300+	DCGY017082	DoC
	PRINTER (only for conduction test)	HP	C2642A	MY79J1D00G	B94C2642X
3	MODEM	ACEEX	1414	0206026775	IFAXDM1414

NO.	SIGNAL CABLE DESCRIPTION OF THE ABOVE SUPPORT UNITS
1	NA
2	1.6 m braid shielded wire, terminated with DB25 and DB9 connector via metallic frame, w/o core
3	1.2 m braid shielded wire, terminated with DB25 and DB9 connector via metallic frame, w/o core.

**NOTE:** All power cords of the above support units are non shielded (1.8m).

### 3.5 CONFIGURATION OF SYSTEM UNDER TEST

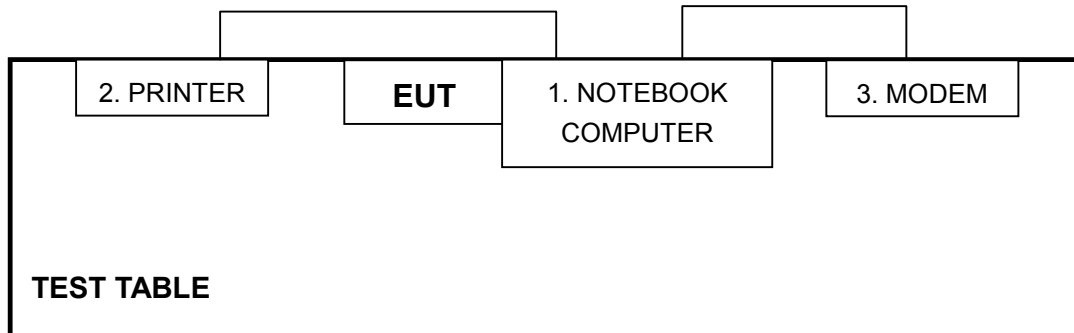

**NOTE:** 1. Please refer to the photos of test configuration in Item 5 also.

## 4. TEST TYPES AND RESULTS

### 4.1 CONDUCTED EMISSION MEASUREMENT

#### 4.1.1 LIMITS OF CONDUCTED EMISSION MEASUREMENT

FREQUENCY OF EMISSION (MHz)	CONDUCTED LIMIT (dB $\mu$ V)	
	Quasi-peak	Average
0.15-0.5	66 to 56	56 to 46
0.5-5	56	46
5-30	60	50

- NOTE:**
1. The lower limit shall apply at the transition frequencies.
  2. The limit decreases in line with the logarithm of the frequency in the range of 0.15 to 0.50 MHz.
  3. All emanations from a class A/B digital device or system, including any network of conductors and apparatus connected thereto, shall not exceed the level of field strengths specified above.

#### 4.1.2 TEST INSTRUMENTS

DESCRIPTION & MANUFACTURER	MODEL NO.	SERIAL NO.	CALIBRATED UNTIL
Test Receiver	ESCS 30	100375	Sep. 19, 2006
Line-Impedance Stabilization Network(for EUT)	ENV-216	100071	Nov. 10, 2006
ROHDE & SCHWARZ LISN	KNW-407	8/1395/12	Jul. 19, 2006
RF Signal Cable	RG233/U	Cable_CA_02	Dec. 10, 2006
Terminator(for KYORITSU)	50	2	Oct. 08, 2006
Software	ADT_Cond_V7.3.2	NA	NA

- NOTE:**
1. The calibration interval of the above test instruments is 12 months and the calibrations are traceable to NML/ROC and NIST/USA.
  2. The test was performed in ADT Shielded Room No. B.
  3. The VCCI Con B Registration No. is C-2193.



#### 4.1.3 TEST PROCEDURES

- a. The EUT was placed 0.4 meters from the conducting wall of the shielded room with EUT being connected to the power mains through a line impedance stabilization network (LISN). Other support units were connected to the power mains through another LISN. The two LISNs provide 50 ohm/ 50uH of coupling impedance for the measuring instrument.
- b. Both lines of the power mains connected to the EUT were checked for maximum conducted interference.
- c. The frequency range from 150kHz to 30MHz was searched. Emission levels under (Limit - 20dB) was not recorded.

#### 4.1.4 DEVIATION FROM TEST STANDARD

No deviation

#### 4.1.5 TEST SETUP

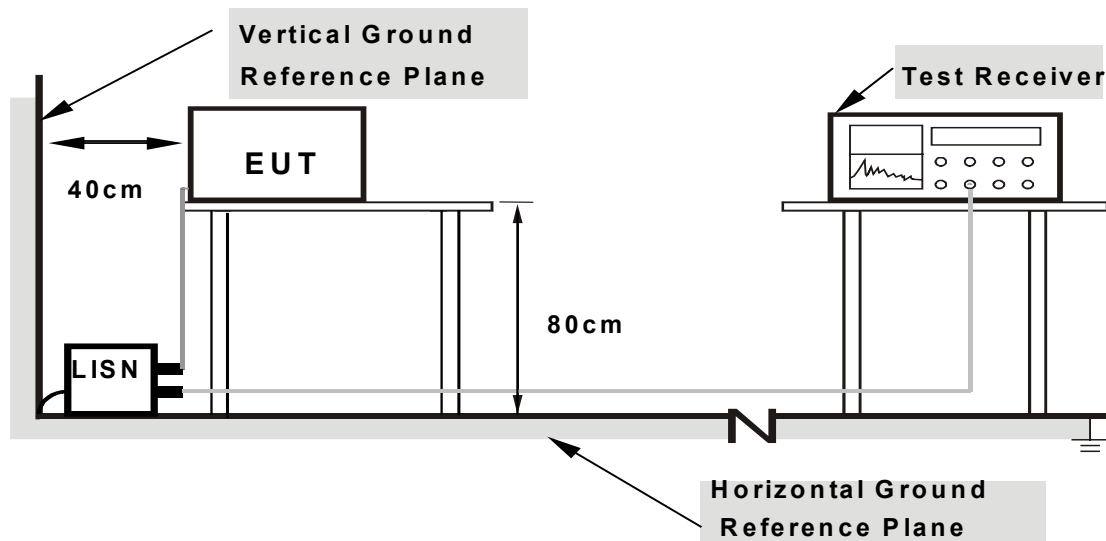

**Note: 1. Support units were connected to second LISN.**

**2. Both of LISNs (AMN) are 80 cm from EUT and at least 80 from other units and other metal planes**

For the actual test configuration, please refer to the related item – Photographs of the Test Configuration.

#### 4.1.6 EUT OPERATING CONDITIONS

- a. Plug the EUT into the support unit 1 (Notebook computer) and placed it on the testing table.
- b. The support unit 1 (Notebook computer) ran a test program “MFGTEST” to enable EUT under transmission condition continuously at specific channel frequency.

#### 4.1.7 TEST RESULTS

#### CONDUCTED WORST-CASE DATA: 802.11g OFDM MODULATION:

EUT TEST CONDITION		MEASUREMENT DETAIL	
CHANNEL	Channel 11	PHASE	Line (L)
MODULATION TYPE	BPSK	6dB BANDWIDTH	9 kHz
TRANSFER RATE	6Mbps	INPUT POWER (SYSTEM)	120Vac, 60 Hz
ENVIRONMENTAL CONDITIONS	25deg. C, 50%RH, 964hPa	TESTED BY	Eric Lee

No	Freq. [MHz]	Corr. Factor (dB)	Reading Value [dB (uV)]		Emission Level [dB (uV)]		Limit [dB (uV)]		Margin (dB)	
			Q.P.	AV.	Q.P.	AV.	Q.P.	AV.	Q.P.	AV.
			1	0.193	9.60	34.63	-	44.23	-	63.91
2	0.213	9.60	28.49	-	38.09	-	63.11	53.11	-25.02	-
3	0.248	9.60	31.57	-	41.17	-	61.84	51.84	-20.67	-
4	0.287	9.60	24.36	-	33.96	-	60.62	50.62	-26.66	-
5	0.435	9.60	14.23	-	23.83	-	57.15	47.15	-33.32	-
6	8.117	9.84	10.98	-	20.82	-	60.00	50.00	-39.18	-

- REMARKS:**
1. Q.P. and AV. are abbreviations of quasi-peak and average individually.
  2. "-": The Quasi-peak reading value also meets average limit and measurement with the average detector is unnecessary.
  3. The emission levels of other frequencies were very low against the limit.
  4. Margin value = Emission level - Limit value
  5. Correction factor = Insertion loss + Cable loss
  6. Emission Level = Correction Factor + Reading Value.

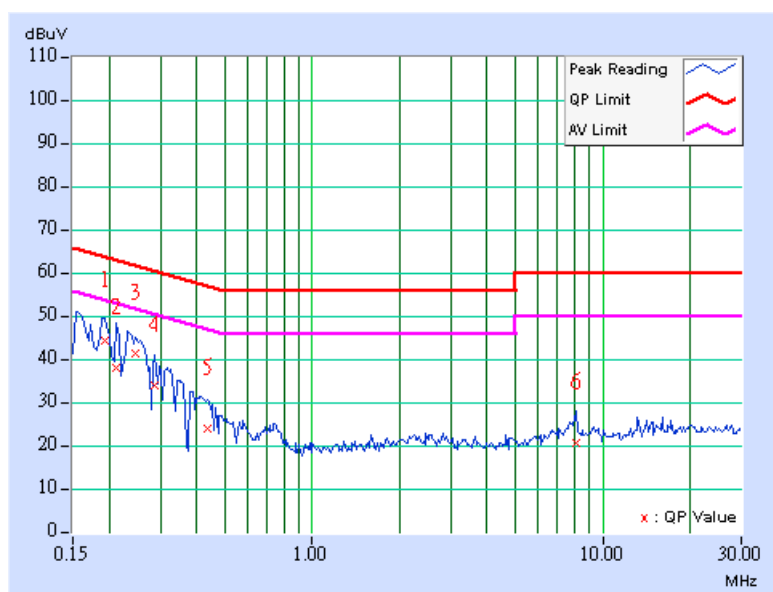

EUT TEST CONDITION		MEASUREMENT DETAIL	
CHANNEL	Channel 11	PHASE	Neutral (N)
MODULATION TYPE	BPSK	6dB BANDWIDTH	9 kHz
TRANSFER RATE	6Mbps	INPUT POWER (SYSTEM)	120Vac, 60 Hz
ENVIRONMENTAL CONDITIONS	25deg. C, 50%RH, 964hPa	TESTED BY	Eric Lee

No	Freq. [MHz]	Corr. Factor (dB)	Reading Value [dB (uV)]		Emission Level [dB (uV)]		Limit [dB (uV)]		Margin (dB)	
			Q.P.	AV.	Q.P.	AV.	Q.P.	AV.	Q.P.	AV.
			1	0.162	9.60	35.47	-	45.07	-	65.38
2	0.193	9.60	28.13	-	37.73	-	63.91	53.91	-26.18	-
3	0.251	9.60	29.77	-	39.37	-	61.71	51.71	-22.34	-
4	0.291	9.60	21.88	-	31.48	-	60.51	50.51	-29.03	-
5	0.740	9.60	6.05	-	15.65	-	56.00	46.00	-40.35	-
6	19.711	10.09	8.96	-	19.05	-	60.00	50.00	-40.95	-

- REMARKS:**
1. Q.P. and AV. are abbreviations of quasi-peak and average individually.
  2. "-": The Quasi-peak reading value also meets average limit and measurement with the average detector is unnecessary.
  3. The emission levels of other frequencies were very low against the limit.
  4. Margin value = Emission level - Limit value
  5. Correction factor = Insertion loss + Cable loss
  6. Emission Level = Correction Factor + Reading Value.

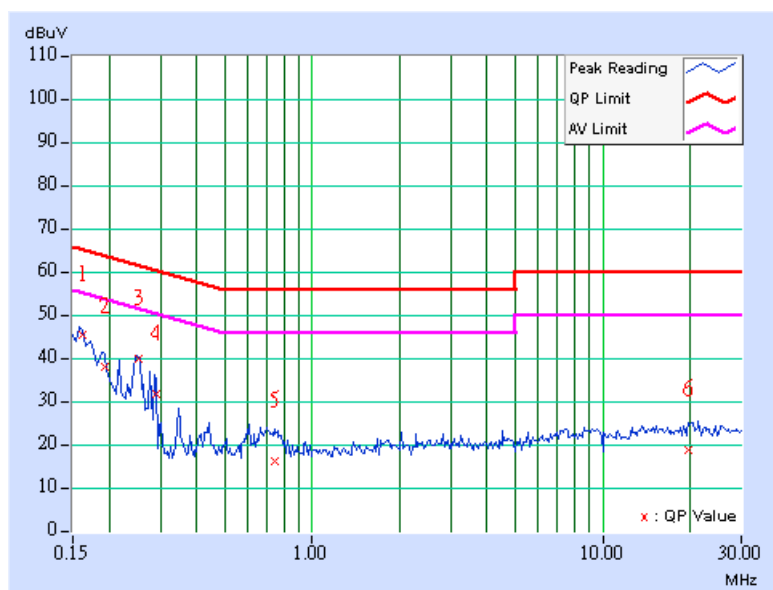

### DRAFT 802.11n (20MHz) OFDM MODULATION:

EUT TEST CONDITION		MEASUREMENT DETAIL	
CHANNEL	Channel 11	PHASE	Line (L)
MODULATION TYPE	BPSK	6dB BANDWIDTH	9 kHz
TRANSFER RATE	6.5Mbps	INPUT POWER (SYSTEM)	120Vac, 60 Hz
ENVIRONMENTAL CONDITIONS	25deg. C, 65%RH, 964hPa	TESTED BY	Eric Lee

No	Freq. [MHz]	Corr. Factor (dB)	Reading Value [dB (uV)]		Emission Level [dB (uV)]		Limit [dB (uV)]		Margin (dB)	
			Q.P.	AV.	Q.P.	AV.	Q.P.	AV.	Q.P.	AV.
			1	0.154	9.60	36.63	-	46.23	-	65.79
2	0.205	9.60	27.91	-	37.51	-	63.42	53.42	-25.91	-
3	0.232	9.60	26.67	-	36.27	-	62.38	52.38	-26.11	-
4	0.279	9.60	21.38	-	30.98	-	60.85	50.85	-29.87	-
5	0.404	9.60	9.51	-	19.11	-	57.77	47.77	-38.66	-
6	7.738	9.82	9.95	-	19.77	-	60.00	50.00	-40.23	-

- REMARKS:**
1. Q.P. and AV. are abbreviations of quasi-peak and average individually.
  2. "-": The Quasi-peak reading value also meets average limit and measurement with the average detector is unnecessary.
  3. The emission levels of other frequencies were very low against the limit.
  4. Margin value = Emission level - Limit value
  5. Correction factor = Insertion loss + Cable loss
  6. Emission Level = Correction Factor + Reading Value.

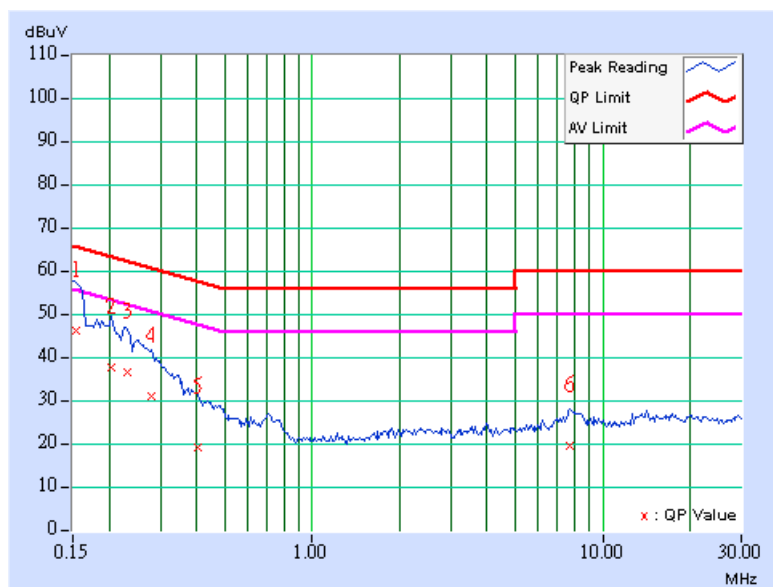

EUT TEST CONDITION		MEASUREMENT DETAIL	
CHANNEL	Channel 11	PHASE	Neutral (N)
MODULATION TYPE	BPSK	6dB BANDWIDTH	9 kHz
TRANSFER RATE	6.5Mbps	INPUT POWER (SYSTEM)	120Vac, 60 Hz
ENVIRONMENTAL CONDITIONS	25deg. C, 50%RH, 964hPa	TESTED BY	Eric Lee

No	Freq. [MHz]	Corr. Factor (dB)	Reading Value [dB (uV)]		Emission Level [dB (uV)]		Limit [dB (uV)]		Margin (dB)	
			Q.P.	AV.	Q.P.	AV.	Q.P.	AV.	Q.P.	AV.
1	0.158	9.60	35.83	-	45.43	-	65.58	55.58	-20.15	-
2	0.173	9.60	30.43	-	40.03	-	64.79	54.79	-24.76	-
3	0.213	9.60	27.79	-	37.39	-	63.11	53.11	-25.72	-
4	0.252	9.60	29.90	-	39.50	-	61.71	51.71	-22.21	-
5	0.283	9.60	22.10	-	31.70	-	60.73	50.73	-29.03	-
6	9.414	9.88	7.99	-	17.87	-	60.00	50.00	-42.13	-

- REMARKS:**
1. Q.P. and AV. are abbreviations of quasi-peak and average individually.
  2. "-": The Quasi-peak reading value also meets average limit and measurement with the average detector is unnecessary.
  3. The emission levels of other frequencies were very low against the limit.
  4. Margin value = Emission level - Limit value
  5. Correction factor = Insertion loss + Cable loss
  6. Emission Level = Correction Factor + Reading Value.

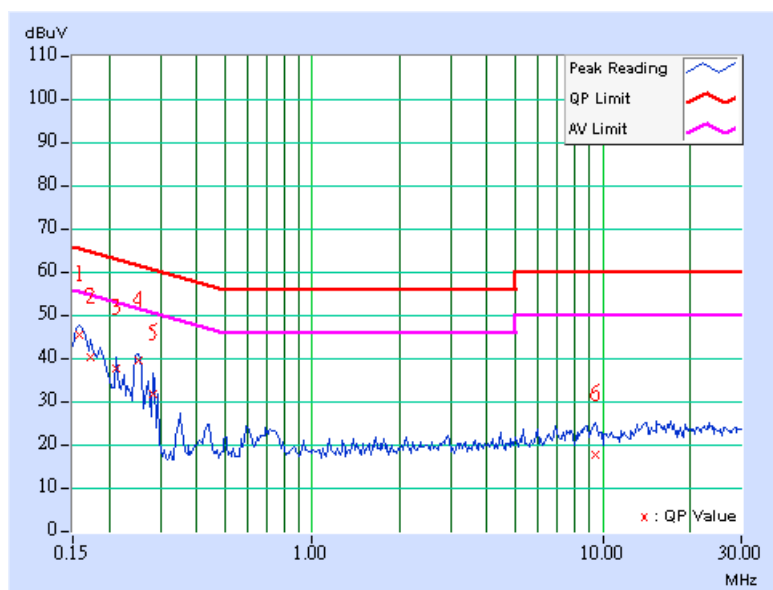

### DRAFT 802.11n (40MHz) OFDM MODULATION:

EUT TEST CONDITION		MEASUREMENT DETAIL	
CHANNEL	Channel 7	PHASE	Line (L)
MODULATION TYPE	BPSK	6dB BANDWIDTH	9 kHz
TRANSFER RATE	13.5Mbps	INPUT POWER (SYSTEM)	120Vac, 60 Hz
ENVIRONMENTAL CONDITIONS	25deg. C, 50%RH, 964hPa	TESTED BY	Eric Lee

No	Freq. [MHz]	Corr. Factor (dB)	Reading Value [dB (uV)]		Emission Level [dB (uV)]		Limit [dB (uV)]		Margin (dB)	
			Q.P.	AV.	Q.P.	AV.	Q.P.	AV.	Q.P.	AV.
			1	0.154	9.60	36.14	-	45.74	-	65.79
2	0.185	9.60	30.10	-	39.70	-	64.25	54.25	-24.55	-
3	0.228	9.60	25.89	-	35.49	-	62.52	52.52	-27.03	-
4	0.255	9.60	28.69	-	38.29	-	61.58	51.58	-23.29	-
5	0.283	9.60	25.32	-	34.92	-	60.73	50.73	-25.81	-
6	8.172	9.84	11.37	-	21.21	-	60.00	50.00	-38.79	-

- REMARKS:**
1. Q.P. and AV. are abbreviations of quasi-peak and average individually.
  2. "-": The Quasi-peak reading value also meets average limit and measurement with the average detector is unnecessary.
  3. The emission levels of other frequencies were very low against the limit.
  4. Margin value = Emission level - Limit value
  5. Correction factor = Insertion loss + Cable loss
  6. Emission Level = Correction Factor + Reading Value.

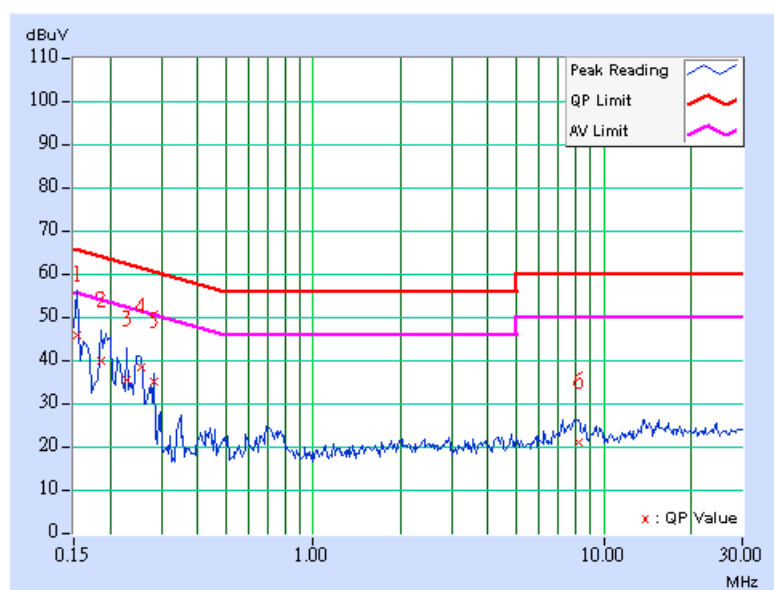

EUT TEST CONDITION		MEASUREMENT DETAIL	
CHANNEL	Channel 7	PHASE	Neutral (N)
MODULATION TYPE	BPSK	6dB BANDWIDTH	9 kHz
TRANSFER RATE	13.5Mbps	INPUT POWER (SYSTEM)	120Vac, 60 Hz
ENVIRONMENTAL CONDITIONS	25deg. C, 50%RH, 964hPa	TESTED BY	Eric Lee

No	Freq. [MHz]	Corr. Factor (dB)	Reading Value [dB (uV)]		Emission Level [dB (uV)]		Limit [dB (uV)]		Margin (dB)	
			Q.P.	AV.	Q.P.	AV.	Q.P.	AV.	Q.P.	AV.
			1	0.156	9.60	35.94	-	45.54	-	65.70
2	0.216	9.60	25.25	-	34.85	-	62.96	52.96	-28.11	-
3	0.252	9.60	29.81	-	39.41	-	61.71	51.71	-22.30	-
4	0.291	9.60	22.40	-	32.00	-	60.51	50.51	-28.51	-
5	5.113	9.74	1.86	-	11.60	-	60.00	50.00	-48.40	-
6	16.746	10.03	6.42	-	16.45	-	60.00	50.00	-43.55	-

- REMARKS:**
1. Q.P. and AV. are abbreviations of quasi-peak and average individually.
  2. "-": The Quasi-peak reading value also meets average limit and measurement with the average detector is unnecessary.
  3. The emission levels of other frequencies were very low against the limit.
  4. Margin value = Emission level - Limit value
  5. Correction factor = Insertion loss + Cable loss
  6. Emission Level = Correction Factor + Reading Value.

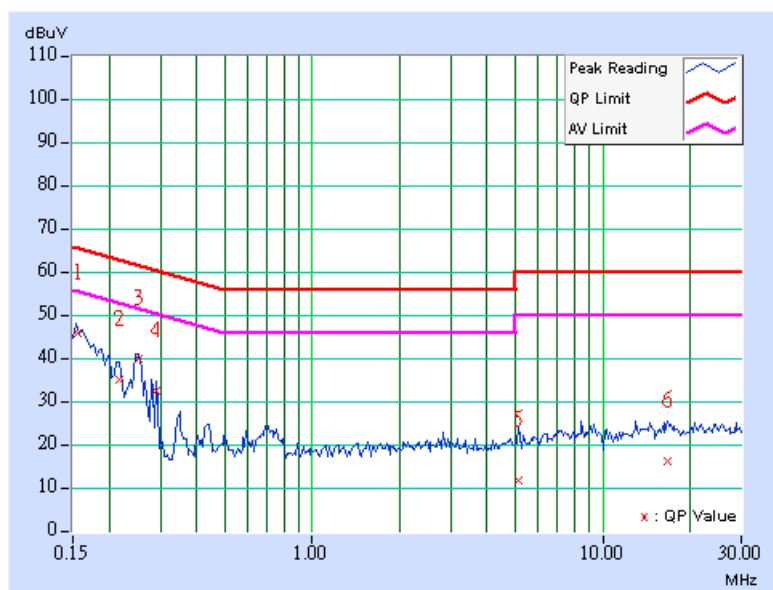



## 4.2 RADIATED EMISSION MEASUREMENT

### 4.2.1 LIMITS OF RADIATED EMISSION MEASUREMENT

Emissions radiated outside of the specified bands, shall be according to the general radiated limits in 15.209 as following:

FREQUENCIES (MHz)	FIELD STRENGTH (microvolts/meter)	MEASUREMENT DISTANCE (meters)
0.009 ~ 0.490	2400 / F(kHz)	300
0.490 ~ 1.705	24000 / F(kHz)	30
1.705 ~ 30.0	30	30
30 ~ 88	100	3
88 ~ 216	150	3
216 ~ 960	200	3
Above 960	500	3

**NOTE:**

1. The lower limit shall apply at the transition frequencies.
2. Emission level (dBuV/m) = 20 log Emission level (uV/m).
3. As shown in 15.35(b), for frequencies above 1000MHz, the field strength limits are based on average detector, however, the peak field strength of any emission shall not exceed the maximum permitted average limits, specified above by more than 20dB under any condition of modulation.



#### 4.2.2 TEST INSTRUMENTS

DESCRIPTION & MANUFACTURER	MODEL NO.	SERIAL NO.	CALIBRATED UNTIL
Test Receiver ROHDE & SCHWARZ	ESMI	839013/007 839379/002	Jan. 24, 2007
Spectrum Analyzer ROHDE & SCHWARZ	FSEK30	100049	Aug. 14, 2006
BILOG Antenna SCHWARZBECK	VULB9163	121	Jun. 01, 2006
HORN Antenna SCHWARZBECK	BBHA 9120 D	9120D-407	Jan. 22, 2007
HORN Antenna SCHWARZBECK	BBHA 9170	BBHA9170242	Jan. 19, 2007
Preamplifier Agilent	8449B	3008A01911	Sep. 22, 2006
RF signal cable HUBER+SUHNNER	SUCOFLEX 104	218188/218189	Dec. 13, 2006
RF signal cable Worken	8D-FB	Cable-HYCH5-02	Apr. 21, 2006
Software ADT.	ADT_Radiated_ V7.6.01	NA	NA
Antenna Tower EMCO	2070/2080	512.835.4684	NA
Antenna Tower Controller EMCO	2090	NA	NA
Turn Table EMCO	2087-2.03	NA	NA
Turn Table Controller EMCO	2090	NA	NA

- NOTE:**
1. The calibration interval of the above test instruments is 12 months and the calibrations are traceable to NML/ROC and NIST/USA.
  2. The test was performed in HwaYa Chamber 4.
  3. The horn antenna and HP preamplifier (model: 8449B) are used only for the measurement of emission frequency above 1GHz if tested.
  4. The IC Site Registration No. is IC4924-4.

#### 4.2.3 TEST PROCEDURES

- a. The EUT was placed on the top of a rotating table 0.8 meters above the ground at a 3 meters semi-anechoic chamber. The table was rotated 360 degrees to determine the position of the highest radiation.
- b. The EUT was set 3 meters away from the interference-receiving antenna, which was mounted on the top of a variable-height antenna tower.
- c. The antenna is a broadband antenna, and its height is varied from one meter to four meters above the ground to determine the maximum value of the field strength. Both horizontal and vertical polarizations of the antenna are set to make the measurement.
- d. For each suspected emission, the EUT was arranged to its worst case and then the antenna was tuned to heights from 1 meter to 4 meters and the rotatable table was turned from 0 degrees to 360 degrees to find the maximum reading.
- e. The test-receiver system was set to Peak Detect Function and Specified Bandwidth with Maximum Hold Mode.
- f. If the emission level of the EUT in peak mode was lower than the limit specified, then testing could be stopped and the peak values of the EUT would be reported. Otherwise the emissions would be re-tested one by one using peak, quasi-peak or average method as specified and then reported in a data sheet.

**NOTE:**

1. The resolution bandwidth and video bandwidth of test receiver/spectrum analyzer is 120kHz for Peak detection (PK) and Quasi-peak detection (QP) at frequency below 1GHz.
2. The resolution bandwidth and video bandwidth of test receiver/spectrum analyzer is 1 MHz for Peak detection at frequency above 1GHz.
3. The resolution bandwidth of test receiver/spectrum analyzer is 1MHz and the video bandwidth is 10Hz for Average detection (AV) at frequency above 1GHz.

#### 4.2.4 DEVIATION FROM TEST STANDARD

No deviation

#### 4.2.5 TEST SETUP

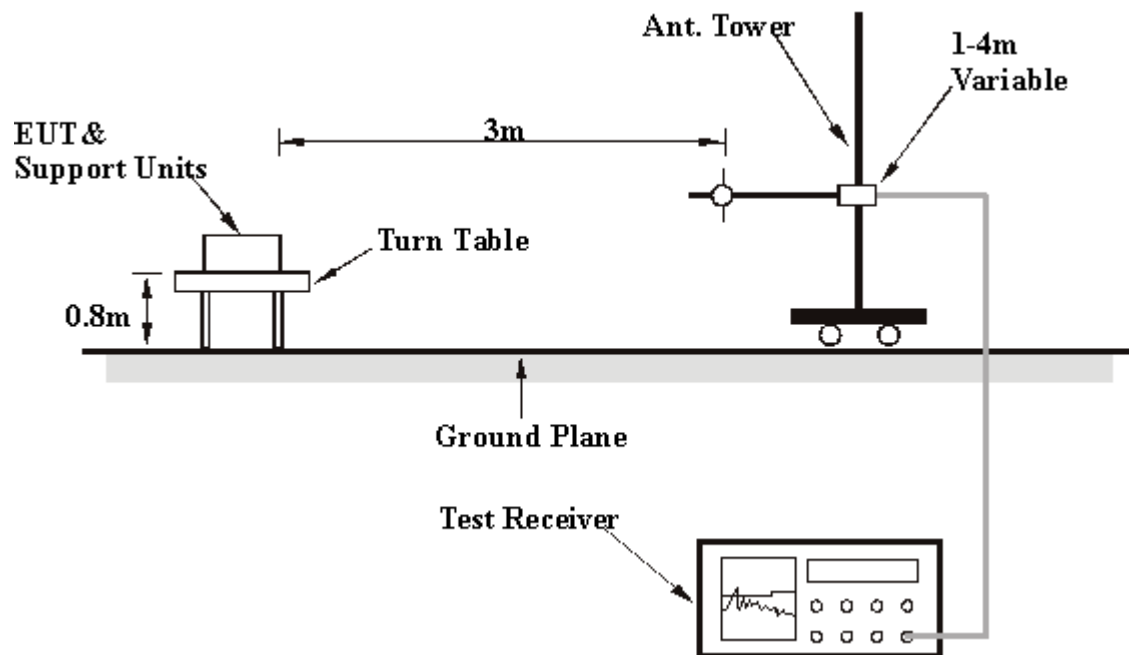

For the actual test configuration, please refer to the related item – Photographs of the Test Configuration.

#### 4.2.6 EUT OPERATING CONDITIONS

Same as 4.1.6

## 4.2.7 TEST RESULTS

### BELOW 1GHz WORST-CASE DATA:

EUT TEST CONDITION		MEASUREMENT DETAIL	
CHANNEL	Channel 1	FREQUENCY RANGE	Below 1000MHz
MODULATION TYPE	BPSK for 802.11g	INPUT POWER (SYSTEM)	120Vac, 60 Hz
TRANSFER RATE	6Mbps	DETECTOR FUNCTION	Quasi-Peak
ENVIRONMENTAL CONDITIONS	25deg. C, 65%RH, 964hPa	TESTED BY	Eric Lee

ANTENNA POLARITY & TEST DISTANCE: HORIZONTAL AT 3 M								
NO.	FREQ. (MHz)	EMISSION LEVEL (dBuV/m)	LIMIT (dBuV/m)	MARGIN (dB)	ANTENNA HEIGHT (m)	TABLE ANGLE (Degree)	RAW VALUE (dBuV)	CORRECTION FACTOR (dB/m)
1	133.49	28.10 QP	43.50	-15.40	1.25 H	125	15.90	12.20
2	166.84	28.20 QP	43.50	-15.30	1.37 H	265	17.70	10.60
3	200.24	32.90 QP	43.50	-10.60	1.37 H	268	22.70	10.20
4	233.51	32.10 QP	46.00	-13.90	1.41 H	161	19.60	12.50
5	300.35	33.70 QP	46.00	-12.30	1.12 H	157	17.80	15.90
6	330.12	24.50 QP	46.00	-21.50	1.15 H	217	8.10	16.40
7	400.04	28.90 QP	46.00	-17.10	2.20 H	154	10.20	18.70
8	499.88	27.80 QP	46.00	-18.20	1.00 H	163	6.90	20.90
9	637.50	31.60 QP	46.00	-14.40	2.20 H	172	8.00	23.60
10	696.75	34.30 QP	46.00	-11.70	1.15 H	285	9.90	24.40

ANTENNA POLARITY & TEST DISTANCE: VERTICAL AT 3 M								
NO.	FREQ. (MHz)	EMISSION LEVEL (dBuV/m)	LIMIT (dBuV/m)	MARGIN (dB)	ANTENNA HEIGHT (m)	TABLE ANGLE (Degree)	RAW VALUE (dBuV)	CORRECTION FACTOR (dB/m)
1	200.25	25.70 QP	43.50	-17.80	1.51 V	83	15.50	10.20
2	210.30	31.90 QP	43.50	-11.60	1.13 V	292	21.00	10.90
3	239.99	23.60 QP	46.00	-22.40	1.55 V	21	10.70	13.00
4	249.97	25.10 QP	46.00	-20.90	1.00 V	2	11.40	13.70
5	299.84	30.90 QP	46.00	-15.10	1.22 V	129	15.00	15.90
6	319.80	36.00 QP	46.00	-10.00	1.00 V	259	19.80	16.20
7	359.80	33.10 QP	46.00	-12.90	1.24 V	90	16.10	17.10
8	400.26	28.90 QP	46.00	-17.10	1.17 V	213	10.20	18.70
9	499.90	33.50 QP	46.00	-12.50	1.05 V	2	12.60	20.90
10	879.20	39.10 QP	46.00	-6.90	1.22 V	339	11.80	27.30

- REMARKS:**
1. Emission level (dBuV/m) = Raw Value (dBuV) + Correction Factor (dB/m).
  2. Correction Factor (dB/m) = Antenna Factor (dB/m) + Cable Factor (dB).
  3. The other emission levels were very low against the limit.
  4. Margin value = Emission level – Limit value.

EUT TEST CONDITION		MEASUREMENT DETAIL	
<b>CHANNEL</b>	Channel 1	<b>FREQUENCY RANGE</b>	Below 1000MHz
<b>MODULATION TYPE</b>	BPSK for draft 802.11n (20MHz)	<b>INPUT POWER (SYSTEM)</b>	120Vac, 60 Hz
<b>TRANSFER RATE</b>	6.5Mbps	<b>DETECTOR FUNCTION</b>	Quasi-Peak
<b>ENVIRONMENTAL CONDITIONS</b>	25deg. C, 65%RH, 964hPa	<b>TESTED BY</b>	Eric Lee

ANTENNA POLARITY & TEST DISTANCE: HORIZONTAL AT 3 M								
NO.	FREQ. (MHz)	EMISSION LEVEL (dBuV/m)	LIMIT (dBuV/m)	MARGIN (dB)	ANTENNA HEIGHT (m)	TABLE ANGLE (Degree)	RAW VALUE (dBuV)	CORRECTION FACTOR (dB/m)
1	133.50	27.80 QP	43.50	-15.70	1.75 H	98	15.70	12.20
2	166.86	29.60 QP	43.50	-13.90	1.00 H	213	19.00	10.60
3	200.25	31.80 QP	43.50	-11.70	1.59 H	95	21.70	10.20
4	233.52	32.70 QP	46.00	-13.30	1.41 H	161	20.10	12.50
5	300.35	34.90 QP	46.00	-11.10	1.12 H	157	19.00	15.90
6	330.12	25.90 QP	46.00	-20.10	1.69 H	35	9.50	16.40
7	400.04	27.50 QP	46.00	-18.50	1.36 H	32	8.80	18.70
8	499.89	28.60 QP	46.00	-17.40	1.78 H	156	7.70	20.90
9	637.49	30.60 QP	46.00	-15.40	1.00 H	31	7.00	23.60
10	696.75	33.20 QP	46.00	-12.80	1.58 H	6	8.90	24.40

ANTENNA POLARITY & TEST DISTANCE: VERTICAL AT 3 M								
NO.	FREQ. (MHz)	EMISSION LEVEL (dBuV/m)	LIMIT (dBuV/m)	MARGIN (dB)	ANTENNA HEIGHT (m)	TABLE ANGLE (Degree)	RAW VALUE (dBuV)	CORRECTION FACTOR (dB/m)
1	200.24	26.30 QP	43.50	-17.20	1.59 V	356	16.10	10.20
2	210.32	32.50 QP	43.50	-11.00	1.11 V	5	21.60	10.90
3	240.00	24.60 QP	46.00	-21.40	1.01 V	107	11.60	13.00
4	249.97	26.50 QP	46.00	-19.50	1.53 V	62	12.80	13.70
5	299.86	31.80 QP	46.00	-14.20	1.82 V	207	15.90	15.90
6	319.80	36.00 QP	46.00	-10.00	1.11 V	209	19.80	16.20
7	359.80	34.20 QP	46.00	-11.80	1.26 V	62	17.10	17.10
8	400.26	29.20 QP	46.00	-16.80	1.40 V	203	10.50	18.70
9	499.90	32.90 QP	46.00	-13.10	1.86 V	66	12.00	20.90
10	879.21	40.00 QP	46.00	-6.00	1.22 V	339	12.70	27.30

- REMARKS:**
1. Emission level (dBuV/m) = Raw Value (dBuV) + Correction Factor (dB/m).
  2. Correction Factor (dB/m) = Antenna Factor (dB/m) + Cable Factor (dB).
  3. The other emission levels were very low against the limit.
  4. Margin value = Emission level – Limit value.

EUT TEST CONDITION		MEASUREMENT DETAIL	
CHANNEL	Channel 1	FREQUENCY RANGE	Below 1000MHz
MODULATION TYPE	BPSK for draft 802.11n (40MHz)	INPUT POWER (SYSTEM)	120Vac, 60 Hz
TRANSFER RATE	13.5Mbps	DETECTOR FUNCTION	Quasi-Peak
ENVIRONMENTAL CONDITIONS	25deg. C, 65%RH, 964hPa	TESTED BY	Eric Lee

ANTENNA POLARITY & TEST DISTANCE: HORIZONTAL AT 3 M								
NO.	FREQ. (MHz)	EMISSION LEVEL (dBuV/m)	LIMIT (dBuV/m)	MARGIN (dB)	ANTENNA HEIGHT (m)	TABLE ANGLE (Degree)	RAW VALUE (dBuV)	CORRECTION FACTOR (dB/m)
1	133.51	30.60 QP	43.50	-12.90	1.54 H	333	18.40	12.20
2	166.82	27.50 QP	43.50	-16.00	1.02 H	326	16.90	10.60
3	200.26	33.20 QP	43.50	-10.30	1.63 H	326	23.00	10.20
4	233.52	32.30 QP	46.00	-13.70	1.55 H	258	19.80	12.50
5	300.36	34.30 QP	46.00	-11.70	1.63 H	326	18.40	15.90
6	330.13	25.40 QP	46.00	-20.60	1.45 H	321	9.00	16.40
7	400.06	28.90 QP	46.00	-17.10	2.20 H	154	10.20	18.70
8	499.88	28.50 QP	46.00	-17.50	1.63 H	3	7.60	20.90
9	637.50	32.80 QP	46.00	-13.20	2.20 H	172	9.20	23.60
10	696.75	34.30 QP	46.00	-11.70	4.00 H	2	9.90	24.40

ANTENNA POLARITY & TEST DISTANCE: VERTICAL AT 3 M								
NO.	FREQ. (MHz)	EMISSION LEVEL (dBuV/m)	LIMIT (dBuV/m)	MARGIN (dB)	ANTENNA HEIGHT (m)	TABLE ANGLE (Degree)	RAW VALUE (dBuV)	CORRECTION FACTOR (dB/m)
1	200.26	27.40 QP	43.50	-16.10	1.65 V	32	17.20	10.20
2	210.29	30.90 QP	43.50	-12.60	1.56 V	326	20.00	10.90
3	239.91	25.20 QP	46.00	-20.80	1.11 V	321	12.20	13.00
4	249.97	26.80 QP	46.00	-19.20	1.00 V	45	13.10	13.70
5	299.84	31.40 QP	46.00	-14.60	1.41 V	6	15.50	15.90
6	319.82	37.50 QP	46.00	-8.50	1.24 V	56	21.30	16.20
7	359.80	34.20 QP	46.00	-11.80	1.33 V	66	17.10	17.10
8	400.26	28.90 QP	46.00	-17.10	2.03 V	36	10.20	18.70
9	499.90	33.50 QP	46.00	-12.50	1.10 V	5	12.60	20.90
10	879.20	39.10 QP	46.00	-6.90	1.22 V	54	11.80	27.30

- REMARKS:**
1. Emission level (dBuV/m) = Raw Value (dBuV) + Correction Factor (dB/m).
  2. Correction Factor (dB/m) = Antenna Factor (dB/m) + Cable Factor (dB).
  3. The other emission levels were very low against the limit.
  4. Margin value = Emission level – Limit value.

### 802.11b DSSS MODULATION:

EUT TEST CONDITION		MEASUREMENT DETAIL	
CHANNEL	Channel 1	FREQUENCY RANGE	1 ~ 25GHz
MODULATION TYPE	DBPSK	INPUT POWER (SYSTEM)	120Vac, 60 Hz
TRANSFER RATE	1Mbps	DETECTOR FUNCTION	Peak(PK) Average (AV)
ENVIRONMENTAL CONDITIONS	18deg. C, 65%RH, 964hPa	TESTED BY	Eric Lee

ANTENNA POLARITY & TEST DISTANCE: HORIZONTAL AT 3 M								
NO.	FREQ. (MHz)	EMISSION LEVEL (dBuV/m)	LIMIT (dBuV/m)	MARGIN (dB)	ANTENNA HEIGHT (m)	TABLE ANGLE (Degree)	RAW VALUE (dBuV)	CORRECTION FACTOR (dB/m)
1	2387.00	62.60 PK	74.00	-11.40	1.00 H	350	31.10	31.50
1	<b>2387.00</b>	<b>53.70 AV</b>	<b>54.00</b>	<b>-0.30</b>	<b>1.00 H</b>	<b>350</b>	<b>22.20</b>	<b>31.50</b>
2	2390.00	62.30 PK	74.00	-11.70	1.00 H	350	30.79	31.51
2	2390.00	50.40 AV	54.00	-3.60	1.00 H	350	18.89	31.51
3	*2412.00	108.10 PK			1.00 H	350	76.52	31.58
3	*2412.00	105.90 AV			1.00 H	350	74.32	31.58
4	3216.00	46.80 PK	74.00	-27.20	1.54 H	348	13.57	33.23
4	3216.00	42.00 AV	54.00	-12.00	1.54 H	348	8.77	33.23
5	4824.00	55.10 PK	74.00	-18.90	1.00 H	121	18.14	36.96
5	4824.00	53.10 AV	54.00	-0.90	1.00 H	121	16.14	36.96
6	7236.00	50.40 PK	74.00	-23.60	1.62 H	83	7.40	43.00
6	7236.00	38.20 AV	54.00	-15.80	1.62 H	83	-4.80	43.00



ANTENNA POLARITY & TEST DISTANCE: VERTICAL AT 3 M								
NO.	FREQ. (MHz)	EMISSION LEVEL (dBuV/m)	LIMIT (dBuV/m)	MARGIN (dB)	ANTENNA HEIGHT (m)	TABLE ANGLE (Degree)	RAW VALUE (dBuV)	CORRECTION FACTOR (dB/m)
1	2387.00	54.20 PK	74.00	-19.80	1.03 V	225	22.70	31.50
1	2387.00	44.70 AV	54.00	-9.30	1.03 V	225	13.20	31.50
2	2390.00	54.60 PK	74.00	-19.40	1.03 V	225	23.09	31.51
2	2390.00	44.60 AV	54.00	-9.40	1.03 V	225	13.09	31.51
3	*2412.00	98.30 PK			1.03 V	225	66.72	31.58
3	*2412.00	95.10 AV			1.03 V	225	63.52	31.58
4	3216.00	47.10 PK	74.00	-26.90	1.54 V	346	13.87	33.23
4	3216.00	41.60 AV	54.00	-12.40	1.54 V	346	8.37	33.23
5	4824.00	54.80 PK	74.00	-19.20	1.51 V	125	17.84	36.96
5	4824.00	51.90 AV	54.00	-2.10	1.51 V	125	14.94	36.96
6	7236.00	52.60 PK	74.00	-21.40	1.14 V	83	9.60	43.00
6	7236.00	39.40 AV	54.00	-14.60	1.14 V	83	-3.60	43.00

- REMARKS:**
1. Emission level (dBuV/m) = Raw Value (dBuV) + Correction Factor (dB/m).
  2. Correction Factor (dB/m) = Antenna Factor (dB/m) + Cable Factor (dB).
  3. The other emission levels were very low against the limit.
  4. Margin value = Emission level – Limit value.
  5. The limit value is defined as per 15.247.
  6. “ \* “: Fundamental frequency.



EUT TEST CONDITION		MEASUREMENT DETAIL	
CHANNEL	Channel 6	FREQUENCY RANGE	1 ~ 25GHz
MODULATION TYPE	DBPSK	INPUT POWER (SYSTEM)	120Vac, 60 Hz
TRANSFER RATE	1Mbps	DETECTOR FUNCTION	Peak(PK) Average (AV)
ENVIRONMENTAL CONDITIONS	18deg. C, 65%RH, 964hPa	TESTED BY	Eric Lee

ANTENNA POLARITY & TEST DISTANCE: HORIZONTAL AT 3 M								
NO.	FREQ. (MHz)	EMISSION LEVEL (dBuV/m)	LIMIT (dBuV/m)	MARGIN (dB)	ANTENNA HEIGHT (m)	TABLE ANGLE (Degree)	RAW VALUE (dBuV)	CORRECTION FACTOR (dB/m)
1	*2437.00	107.50 PK			1.03 H	359	75.84	31.66
1	*2437.00	105.40 AV			1.03 H	359	73.74	31.66
2	3249.00	47.90 PK	74.00	-26.10	1.16 H	48	14.58	33.32
2	3249.00	43.10 AV	54.00	-10.90	1.16 H	48	9.78	33.32
3	4874.00	54.00 PK	74.00	-20.00	1.01 H	62	16.85	37.15
3	4874.00	50.10 AV	54.00	-3.90	1.01 H	62	12.95	37.15
4	7311.00	50.10 PK	74.00	-23.90	1.23 H	42	7.01	43.09
4	7311.00	38.20 AV	54.00	-15.80	1.23 H	42	-4.89	43.09

ANTENNA POLARITY & TEST DISTANCE: VERTICAL AT 3 M								
NO.	FREQ. (MHz)	EMISSION LEVEL (dBuV/m)	LIMIT (dBuV/m)	MARGIN (dB)	ANTENNA HEIGHT (m)	TABLE ANGLE (Degree)	RAW VALUE (dBuV)	CORRECTION FACTOR (dB/m)
1	*2437.00	98.10 PK			1.04 V	230	66.44	31.66
1	*2437.00	95.30 AV			1.04 V	230	63.64	31.66
2	3249.00	48.90 PK	74.00	-25.10	1.61 V	359	15.58	33.32
2	3249.00	42.80 AV	54.00	-11.20	1.61 V	359	9.48	33.32
3	4874.00	51.90 PK	74.00	-22.10	1.50 V	126	14.75	37.15
3	4874.00	48.40 AV	54.00	-5.60	1.50 V	126	11.25	37.15
4	7311.00	52.80 PK	74.00	-21.20	1.11 V	72	9.71	43.09
4	7311.00	39.20 AV	54.00	-14.80	1.11 V	72	-3.89	43.09

- REMARKS:**
1. Emission level (dBuV/m) = Raw Value (dBuV) + Correction Factor (dB/m).
  2. Correction Factor (dB/m) = Antenna Factor (dB/m) + Cable Factor (dB).
  3. The other emission levels were very low against the limit.
  4. Margin value = Emission level – Limit value.
  5. The limit value is defined as per 15.247.
  6. “ \* “: Fundamental frequency.



EUT TEST CONDITION		MEASUREMENT DETAIL	
CHANNEL	Channel 11	FREQUENCY RANGE	1 ~ 25GHz
MODULATION TYPE	DBPSK	INPUT POWER (SYSTEM)	120Vac, 60 Hz
TRANSFER RATE	1Mbps	DETECTOR FUNCTION	Peak(PK) Average (AV)
ENVIRONMENTAL CONDITIONS	18deg. C, 65%RH, 964hPa	TESTED BY	Eric Lee

ANTENNA POLARITY & TEST DISTANCE: HORIZONTAL AT 3 M								
NO.	FREQ. (MHz)	EMISSION LEVEL (dBuV/m)	LIMIT (dBuV/m)	MARGIN (dB)	ANTENNA HEIGHT (m)	TABLE ANGLE (Degree)	RAW VALUE (dBuV)	CORRECTION FACTOR (dB/m)
1	*2462.00	108.90 PK			1.04 H	261	77.16	31.74
1	*2462.00	104.00 AV			1.04 H	261	72.26	31.74
2	2483.50	59.20 PK	74.00	-14.80	1.04 H	261	27.39	31.81
2	2483.50	50.30 AV	54.00	-3.70	1.04 H	261	18.49	31.81
3	2486.00	59.90 PK	74.00	-14.10	1.04 H	261	28.08	31.82
3	2486.00	50.40 AV	54.00	-3.60	1.04 H	261	18.58	31.82
4	3282.00	48.40 PK	74.00	-25.60	1.20 H	69	14.98	33.42
4	3282.00	43.80 AV	54.00	-10.20	1.20 H	69	10.38	33.42
5	4924.00	56.20 PK	74.00	-17.80	1.01 H	55	18.91	37.29
5	4924.00	53.20 AV	54.00	-0.80	1.01 H	55	15.91	37.29
6	7386.00	49.80 PK	74.00	-24.20	1.00 H	58	6.42	43.38
6	7386.00	37.90 AV	54.00	-16.10	1.00 H	58	-5.48	43.38

ANTENNA POLARITY & TEST DISTANCE: VERTICAL AT 3 M								
NO.	FREQ. (MHz)	EMISSION LEVEL (dBuV/m)	LIMIT (dBuV/m)	MARGIN (dB)	ANTENNA HEIGHT (m)	TABLE ANGLE (Degree)	RAW VALUE (dBuV)	CORRECTION FACTOR (dB/m)
1	*2462.00	99.20 PK			1.06 V	239	67.46	31.74
1	*2462.00	96.40 AV			1.06 V	239	64.66	31.74
2	2483.50	53.90 PK	74.00	-20.10	1.06 V	239	22.09	31.81
2	2483.50	45.10 AV	54.00	-8.90	1.06 V	239	13.29	31.81
3	2486.00	54.50 PK	74.00	-19.50	1.06 V	239	22.68	31.82
3	2486.00	44.70 AV	54.00	-9.30	1.06 V	239	12.88	31.82
4	3282.00	49.40 PK	74.00	-24.60	1.72 V	3	15.98	33.42
4	3282.00	43.20 AV	54.00	-10.80	1.72 V	3	9.78	33.42
5	4924.00	56.20 PK	74.00	-17.80	1.49 V	130	18.91	37.29
5	4924.00	52.90 AV	54.00	-1.10	1.49 V	130	15.61	37.29
6	7386.00	53.20 PK	74.00	-20.80	1.54 V	66	9.82	43.38
6	7386.00	39.40 AV	54.00	-14.60	1.54 V	66	-3.98	43.38

- REMARKS:**
1. Emission level (dBuV/m) = Raw Value (dBuV) + Correction Factor (dB/m).
  2. Correction Factor (dB/m) = Antenna Factor (dB/m) + Cable Factor (dB).
  3. The other emission levels were very low against the limit.
  4. Margin value = Emission level – Limit value.
  5. The limit value is defined as per 15.247.
  6. “ \* “: Fundamental frequency.

RESTRICTED BANDEDGE (802.11b MODE, CH1, HORIZONTAL )

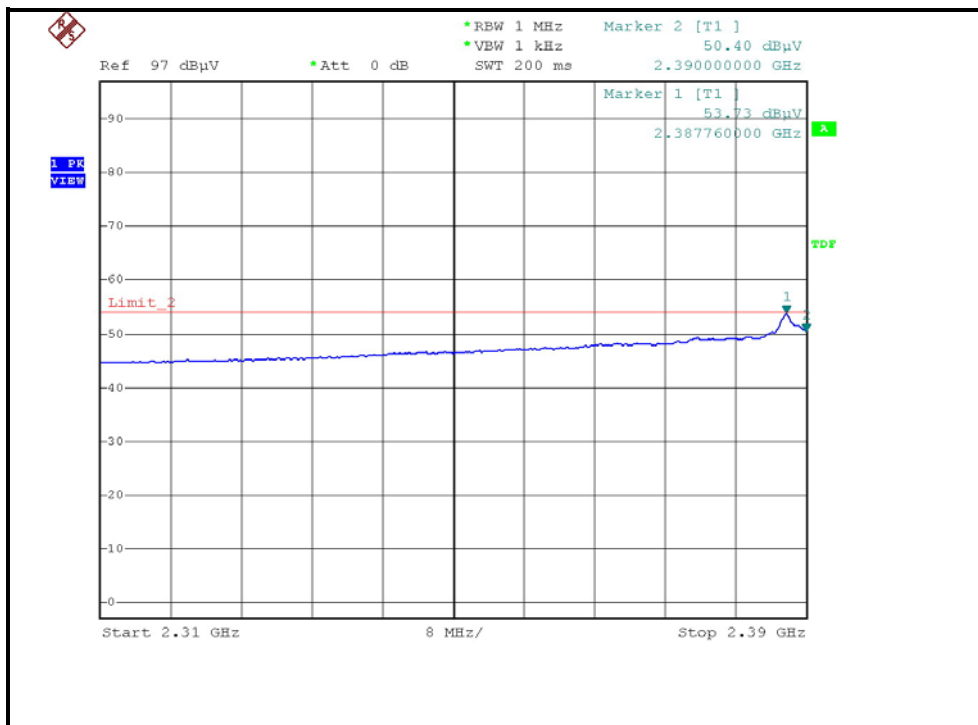
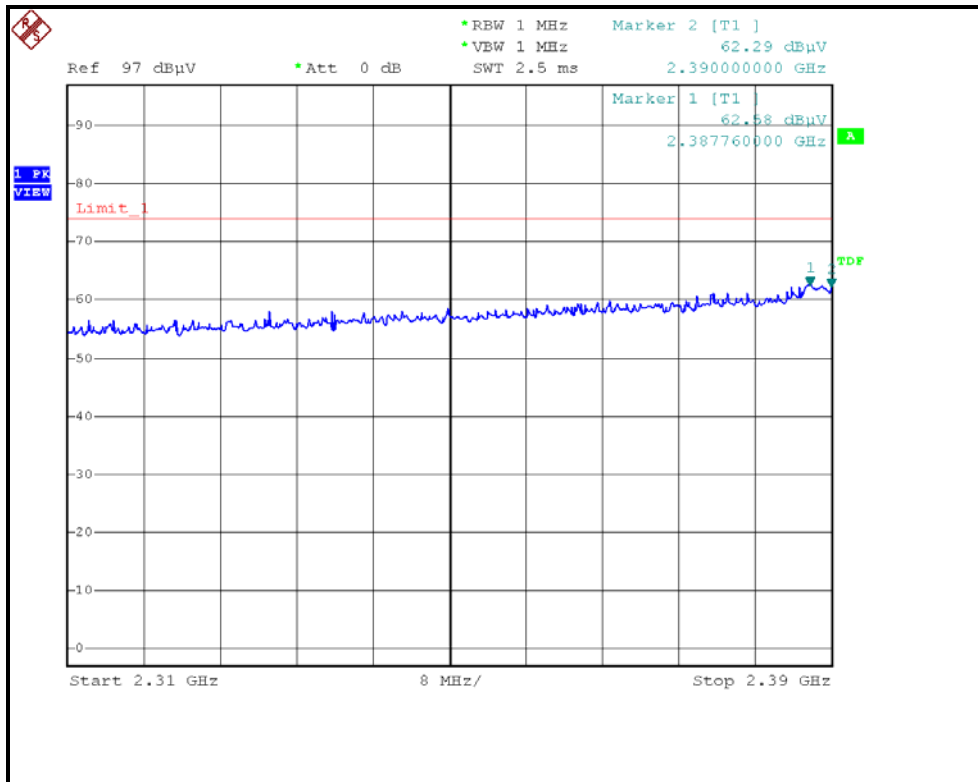

RESTRICTED BANDEDGE (802.11b MODE, CH1, VERTICAL )

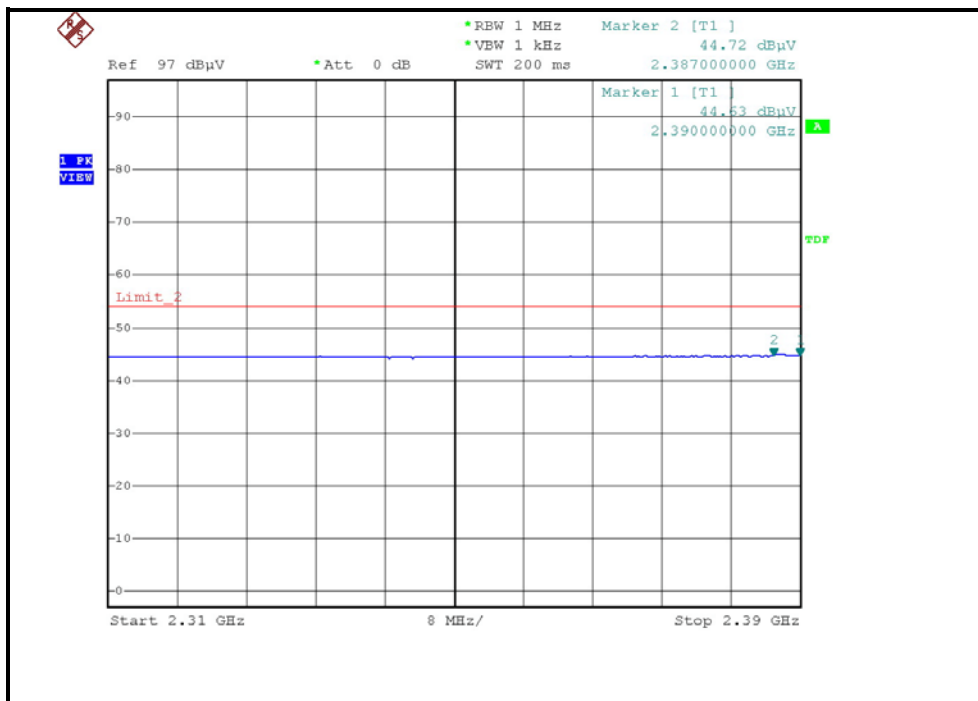
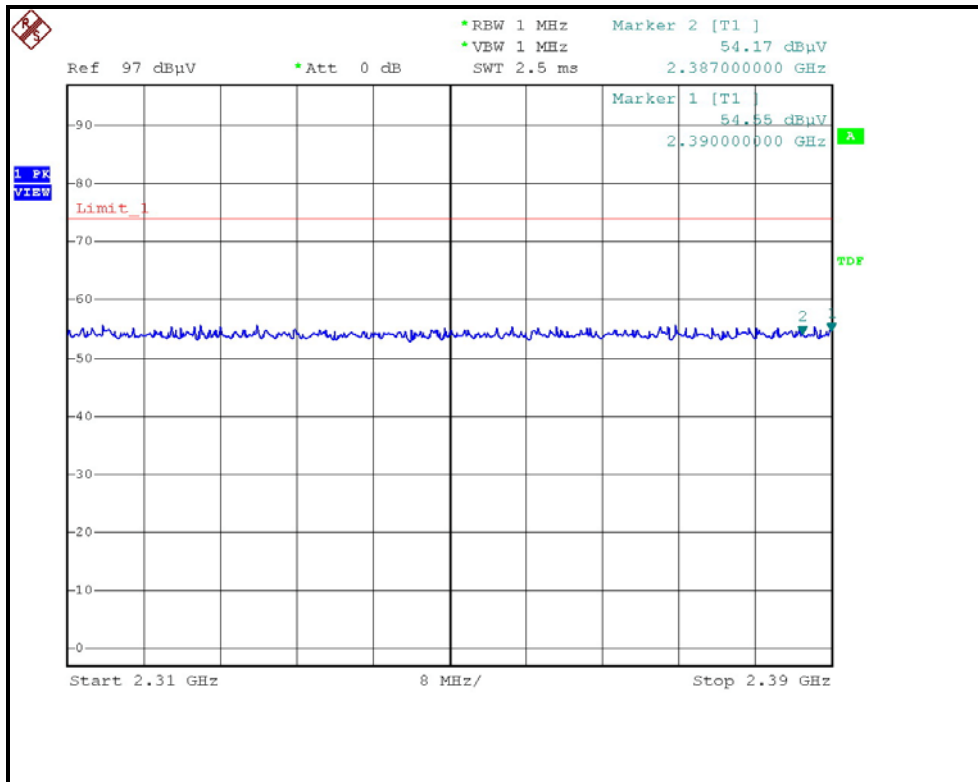

RESTRICTED BANDEDGE (802.11b MODE, CH11, HORIZONTAL )

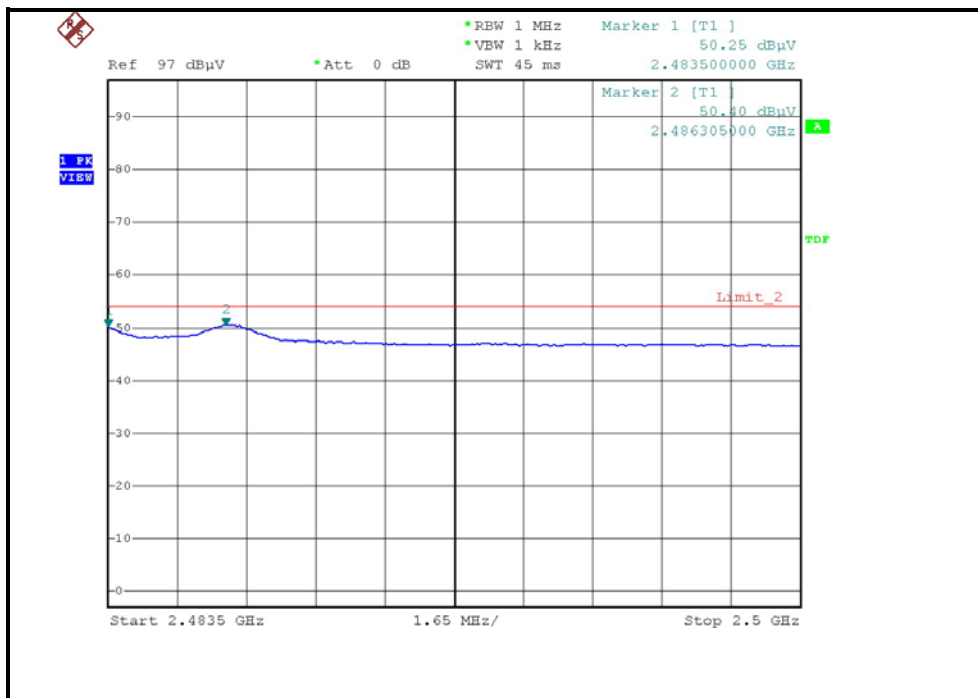
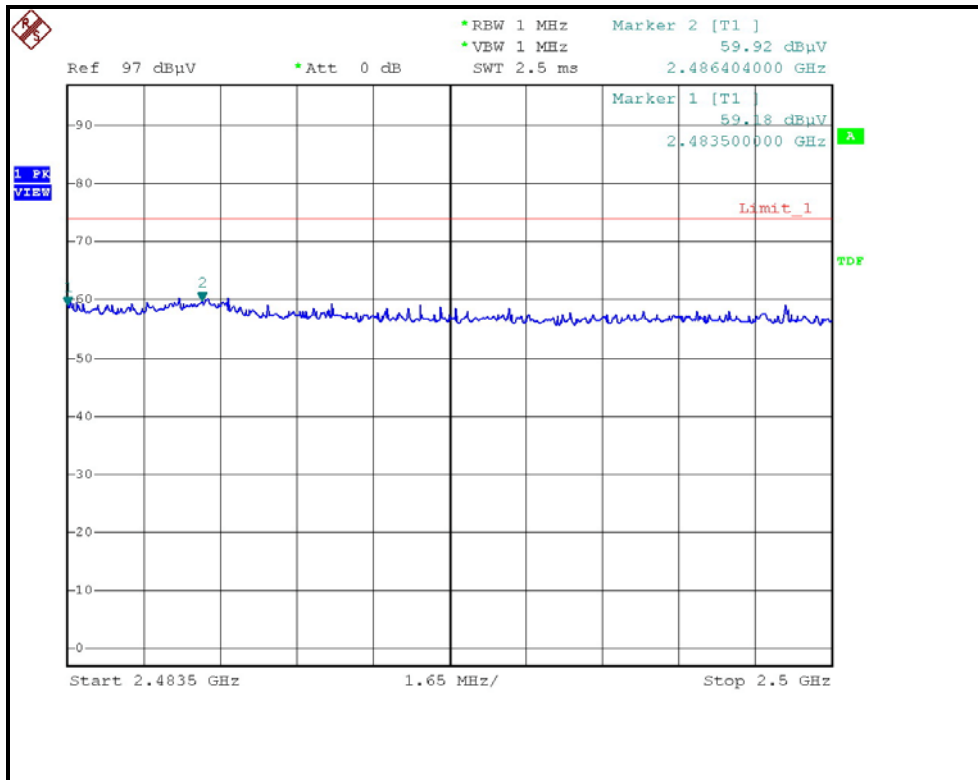

RESTRICTED BANDEDGE (802.11b MODE, CH11, VERTICAL )

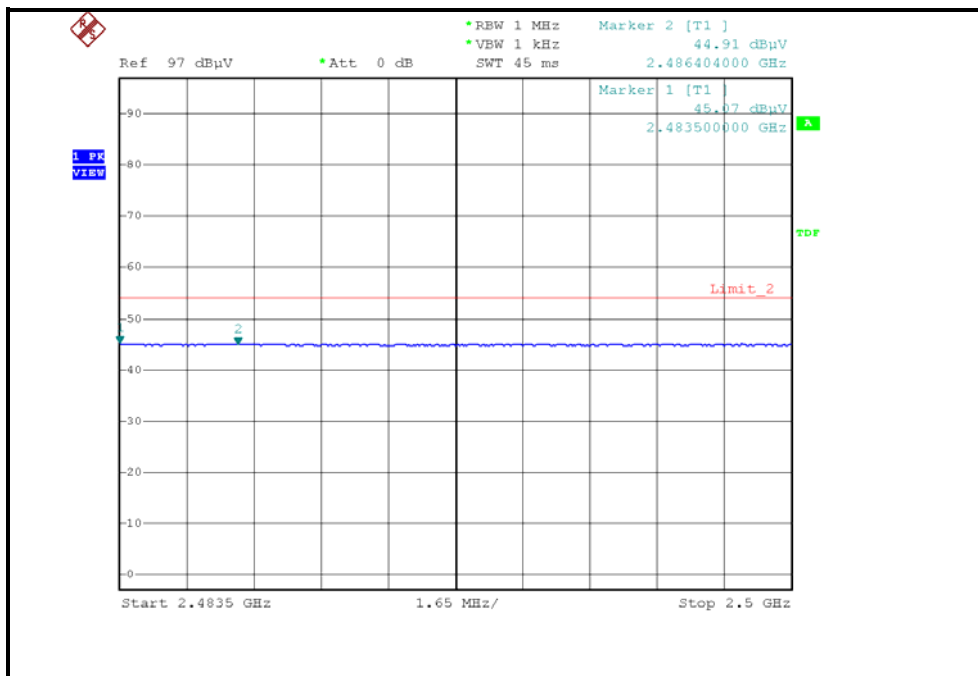
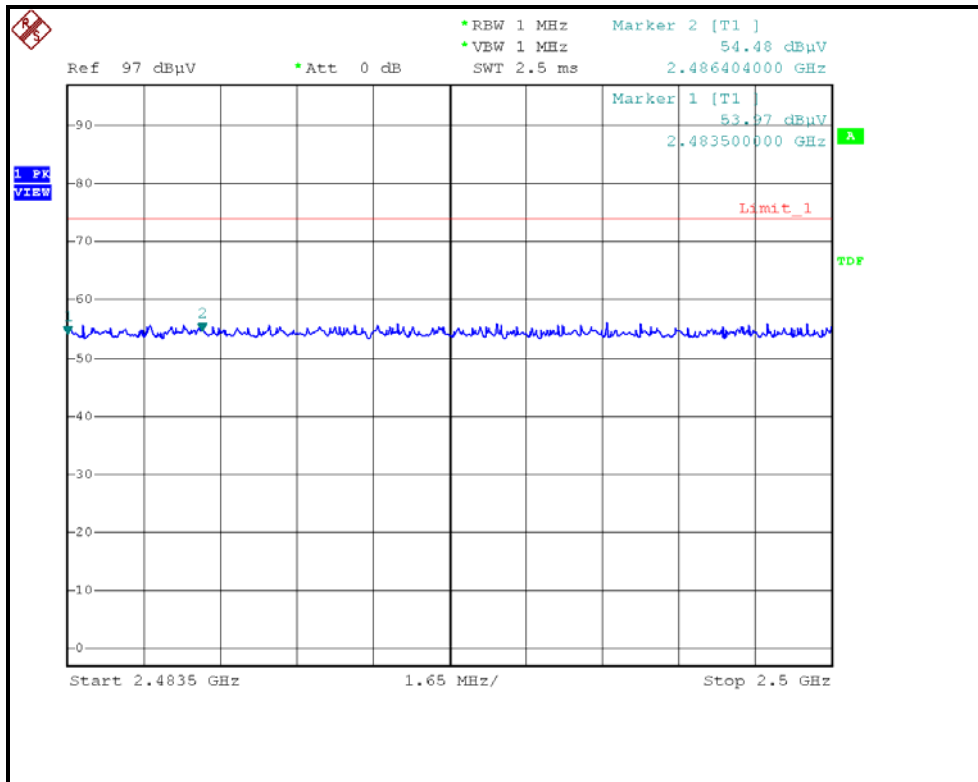



### 802.11g OFDM MODULATION:

EUT TEST CONDITION		MEASUREMENT DETAIL	
CHANNEL	Channel 1	FREQUENCY RANGE	1 ~ 25GHz
MODULATION TYPE	BPSK	INPUT POWER (SYSTEM)	120Vac, 60 Hz
TRANSFER RATE	6Mbps	DETECTOR FUNCTION	Peak(PK) Average (AV)
ENVIRONMENTAL CONDITIONS	18deg. C, 65%RH, 964hPa	TESTED BY	Eric Lee

ANTENNA POLARITY & TEST DISTANCE: HORIZONTAL AT 3 M								
NO.	FREQ. (MHz)	EMISSION LEVEL (dBuV/m)	LIMIT (dBuV/m)	MARGIN (dB)	ANTENNA HEIGHT (m)	TABLE ANGLE (Degree)	RAW VALUE (dBuV)	CORRECTION FACTOR (dB/m)
1	2387.00	62.90 PK	74.00	-11.10	1.37 H	305	31.40	31.50
1	2387.00	50.10 AV	54.00	-3.90	1.37 H	305	18.60	31.50
2	2390.00	65.20 PK	74.00	-8.80	1.37 H	305	33.69	31.51
2	2390.00	47.90 AV	54.00	-6.10	1.37 H	305	16.39	31.51
3	*2412.00	106.00 PK			1.37 H	305	74.42	31.58
3	*2412.00	102.70 AV			1.37 H	305	71.12	31.58
4	3216.00	48.80 PK	74.00	-25.20	1.05 H	111	15.57	33.23
4	3216.00	44.20 AV	54.00	-9.80	1.05 H	111	10.97	33.23
5	4824.00	48.60 PK	74.00	-25.40	1.27 H	104	11.64	36.96
5	4824.00	42.10 AV	54.00	-11.90	1.27 H	104	5.14	36.96
6	7236.00	49.50 PK	74.00	-24.50	1.60 H	73	6.50	43.00
6	7236.00	39.20 AV	54.00	-14.80	1.60 H	73	-3.80	43.00

ANTENNA POLARITY & TEST DISTANCE: VERTICAL AT 3 M								
NO.	FREQ. (MHz)	EMISSION LEVEL (dBuV/m)	LIMIT (dBuV/m)	MARGIN (dB)	ANTENNA HEIGHT (m)	TABLE ANGLE (Degree)	RAW VALUE (dBuV)	CORRECTION FACTOR (dB/m)
1	2387.00	56.00 PK	74.00	-18.00	1.35 V	97	24.50	31.50
1	2387.00	45.50 AV	54.00	-8.50	1.35 V	97	14.00	31.50
2	2390.00	55.50 PK	74.00	-18.50	1.35 V	97	23.99	31.51
2	2390.00	45.20 AV	54.00	-8.80	1.35 V	97	13.69	31.51
3	*2412.00	100.70 PK			1.35 V	97	69.12	31.58
3	*2412.00	97.70 AV			1.35 V	97	66.12	31.58
4	3216.00	48.80 PK	74.00	-25.20	1.19 V	321	15.57	33.23
4	3216.00	44.40 AV	54.00	-9.60	1.19 V	321	11.17	33.23
5	4824.00	49.70 PK	74.00	-24.30	1.05 V	17	12.74	36.96
5	4824.00	43.10 AV	54.00	-10.90	1.05 V	17	6.14	36.96
6	7236.00	49.20 PK	74.00	-24.80	1.14 V	28	6.20	43.00
6	7236.00	38.10 AV	54.00	-15.90	1.14 V	28	-4.90	43.00

- REMARKS:**
1. Emission level (dBuV/m) = Raw Value (dBuV) + Correction Factor (dB/m).
  2. Correction Factor (dB/m) = Antenna Factor (dB/m) + Cable Factor (dB).
  3. The other emission levels were very low against the limit.
  4. Margin value = Emission level – Limit value.
  5. The limit value is defined as per 15.247.
  6. “ \* “: Fundamental frequency.



EUT TEST CONDITION		MEASUREMENT DETAIL	
CHANNEL	Channel 6	FREQUENCY RANGE	1 ~ 25GHz
MODULATION TYPE	BPSK	INPUT POWER (SYSTEM)	120Vac, 60 Hz
TRANSFER RATE	6Mbps	DETECTOR FUNCTION	Peak(PK) Average (AV)
ENVIRONMENTAL CONDITIONS	18deg. C, 65%RH, 964hPa	TESTED BY	Eric Lee

ANTENNA POLARITY & TEST DISTANCE: HORIZONTAL AT 3 M								
NO.	FREQ. (MHz)	EMISSION LEVEL (dBuV/m)	LIMIT (dBuV/m)	MARGIN (dB)	ANTENNA HEIGHT (m)	TABLE ANGLE (Degree)	RAW VALUE (dBuV)	CORRECTION FACTOR (dB/m)
1	*2437.00	106.90 PK			1.39 H	311	75.24	31.66
1	*2437.00	103.80 AV			1.39 H	311	72.14	31.66
2	3249.00	49.20 PK	74.00	-24.80	1.59 H	69	15.88	33.32
2	3249.00	44.20 AV	54.00	-9.80	1.59 H	69	10.88	33.32
3	4874.00	49.10 PK	74.00	-24.90	1.20 H	110	11.95	37.15
3	4874.00	43.00 AV	54.00	-11.00	1.20 H	110	5.85	37.15
4	7311.00	47.10 PK	74.00	-26.90	1.11 H	3	4.01	43.09
4	7311.00	38.90 AV	54.00	-15.10	1.11 H	3	-4.19	43.09

ANTENNA POLARITY & TEST DISTANCE: VERTICAL AT 3 M								
NO.	FREQ. (MHz)	EMISSION LEVEL (dBuV/m)	LIMIT (dBuV/m)	MARGIN (dB)	ANTENNA HEIGHT (m)	TABLE ANGLE (Degree)	RAW VALUE (dBuV)	CORRECTION FACTOR (dB/m)
1	*2437.00	100.90 PK			1.40 V	89	69.24	31.66
1	*2437.00	98.40 AV			1.40 V	89	66.74	31.66
2	3249.00	49.50 PK	74.00	-24.50	1.20 V	330	16.18	33.32
2	3249.00	45.10 AV	54.00	-8.90	1.20 V	330	11.78	33.32
3	4874.00	50.10 PK	74.00	-23.90	1.19 V	120	12.95	37.15
3	4874.00	44.00 AV	54.00	-10.00	1.19 V	120	6.85	37.15
4	7311.00	48.20 PK	74.00	-25.80	1.02 V	63	5.11	43.09
4	7311.00	37.80 AV	54.00	-16.20	1.02 V	63	-5.29	43.09

- REMARKS:**
1. Emission level (dBuV/m) = Raw Value (dBuV) + Correction Factor (dB/m).
  2. Correction Factor (dB/m) = Antenna Factor (dB/m) + Cable Factor (dB).
  3. The other emission levels were very low against the limit.
  4. Margin value = Emission level – Limit value.
  5. The limit value is defined as per 15.247.
  6. “ \* “: Fundamental frequency.



EUT TEST CONDITION		MEASUREMENT DETAIL	
CHANNEL	Channel 11	FREQUENCY RANGE	1 ~ 25GHz
MODULATION TYPE	BPSK	INPUT POWER (SYSTEM)	120Vac, 60 Hz
TRANSFER RATE	6Mbps	DETECTOR FUNCTION	Peak(PK) Average (AV)
ENVIRONMENTAL CONDITIONS	18deg. C, 65%RH, 964hPa	TESTED BY	Eric Lee

ANTENNA POLARITY & TEST DISTANCE: HORIZONTAL AT 3 M								
NO.	FREQ. (MHz)	EMISSION LEVEL (dBuV/m)	LIMIT (dBuV/m)	MARGIN (dB)	ANTENNA HEIGHT (m)	TABLE ANGLE (Degree)	RAW VALUE (dBuV)	CORRECTION FACTOR (dB/m)
1	*2462.00	107.10 PK			1.38 H	311	75.36	31.74
1	*2462.00	103.80 AV			1.38 H	311	72.06	31.74
2	2483.50	58.40 PK	74.00	-15.60	1.38 H	311	26.59	31.81
2	2483.50	49.60 AV	54.00	-4.40	1.38 H	311	17.79	31.81
3	2486.00	58.10 PK	74.00	-15.90	1.38 H	311	26.28	31.82
3	2486.00	50.00 AV	54.00	-4.00	1.38 H	311	18.18	31.82
4	3282.00	48.20 PK	74.00	-25.80	1.59 H	58	14.78	33.42
4	3282.00	45.10 AV	54.00	-8.90	1.59 H	58	11.68	33.42
5	4924.00	48.20 PK	74.00	-25.80	1.00 H	321	10.91	37.29
5	4924.00	43.60 AV	54.00	-10.40	1.00 H	321	6.31	37.29
6	7386.00	49.70 PK	74.00	-24.30	1.59 H	84	6.32	43.38
6	7386.00	39.30 AV	54.00	-14.70	1.59 H	84	-4.08	43.38

ANTENNA POLARITY & TEST DISTANCE: VERTICAL AT 3 M								
NO.	FREQ. (MHz)	EMISSION LEVEL (dBuV/m)	LIMIT (dBuV/m)	MARGIN (dB)	ANTENNA HEIGHT (m)	TABLE ANGLE (Degree)	RAW VALUE (dBuV)	CORRECTION FACTOR (dB/m)
1	*2462.00	103.10 PK			1.39 V	100	71.36	31.74
1	*2462.00	98.10 AV			1.39 V	100	66.36	31.74
2	2483.50	53.90 PK	74.00	-20.10	1.39 V	100	22.09	31.81
2	2483.50	44.50 AV	54.00	-9.50	1.39 V	100	12.69	31.81
3	3282.00	47.20 PK	74.00	-26.80	1.21 V	330	13.78	33.42
3	3282.00	44.90 AV	54.00	-9.10	1.21 V	330	11.48	33.42
4	4924.00	51.60 PK	74.00	-22.40	1.09 V	23	14.31	37.29
4	4924.00	45.10 AV	54.00	-8.90	1.09 V	23	7.81	37.29
5	7386.00	49.30 PK	74.00	-24.70	1.17 V	34	5.92	43.38
5	7386.00	38.30 AV	54.00	-15.70	1.17 V	34	-5.08	43.38

- REMARKS:**
1. Emission level (dBuV/m) = Raw Value (dBuV) + Correction Factor (dB/m).
  2. Correction Factor (dB/m) = Antenna Factor (dB/m) + Cable Factor (dB).
  3. The other emission levels were very low against the limit.
  4. Margin value = Emission level – Limit value.
  5. The limit value is defined as per 15.247.
  6. “ \* “: Fundamental frequency.

RESTRICTED BANDEDGE (802.11g MODE,CH1, HORIZONTAL )

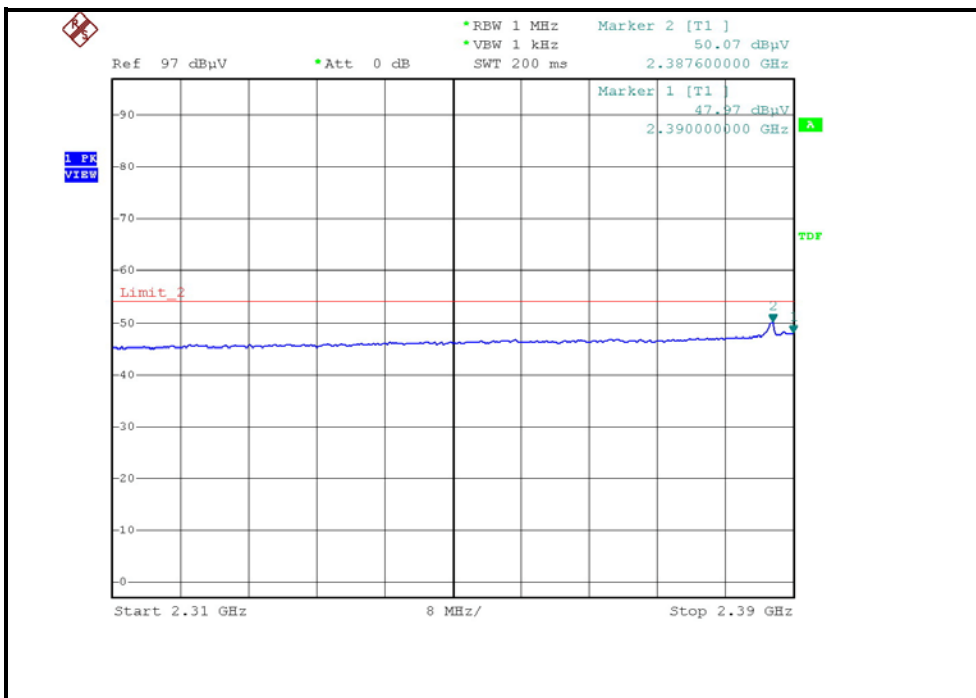
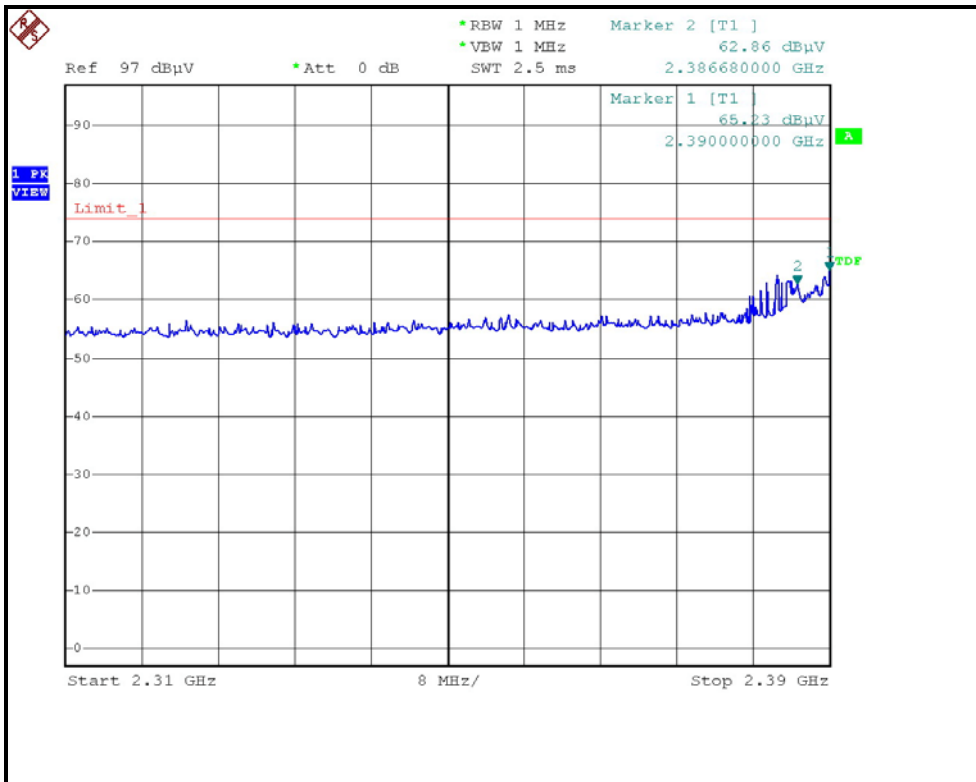

RESTRICTED BANDEDGE (802.11g MODE, CH1, VERTICAL )

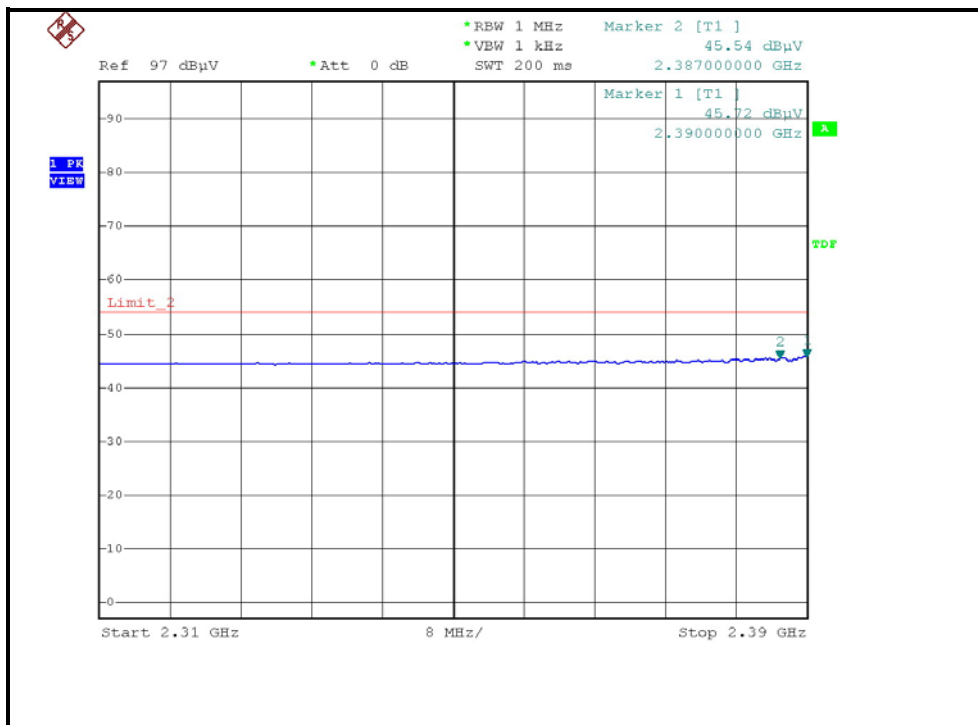
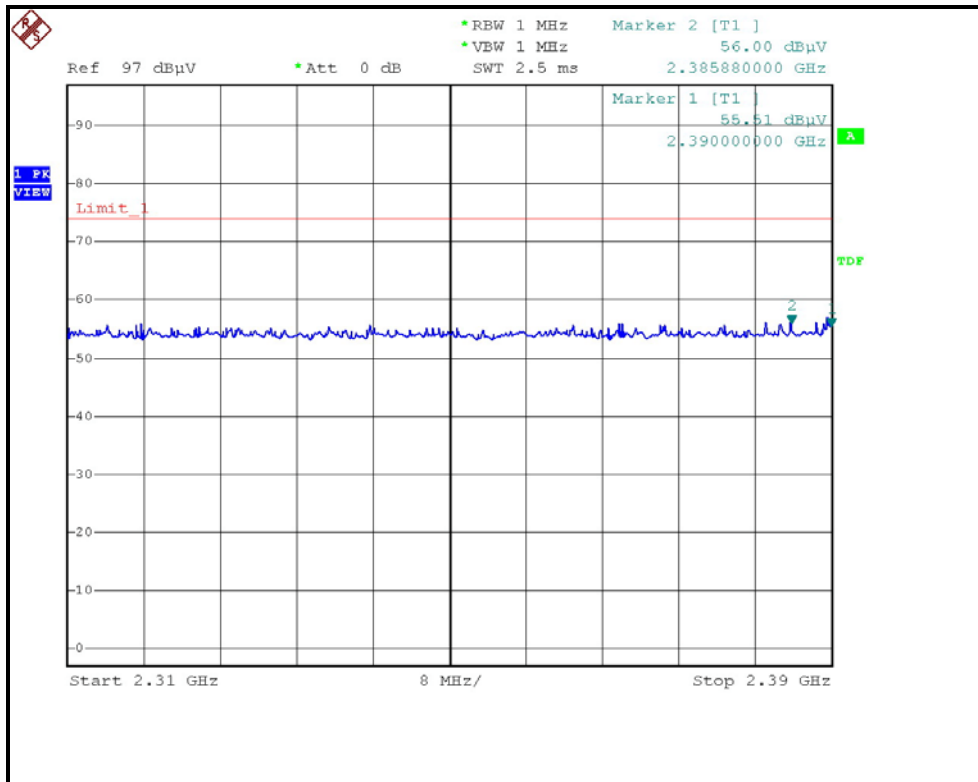

RESTRICTED BANDEDGE (802.11g MODE,CH11, HORIZONTAL )

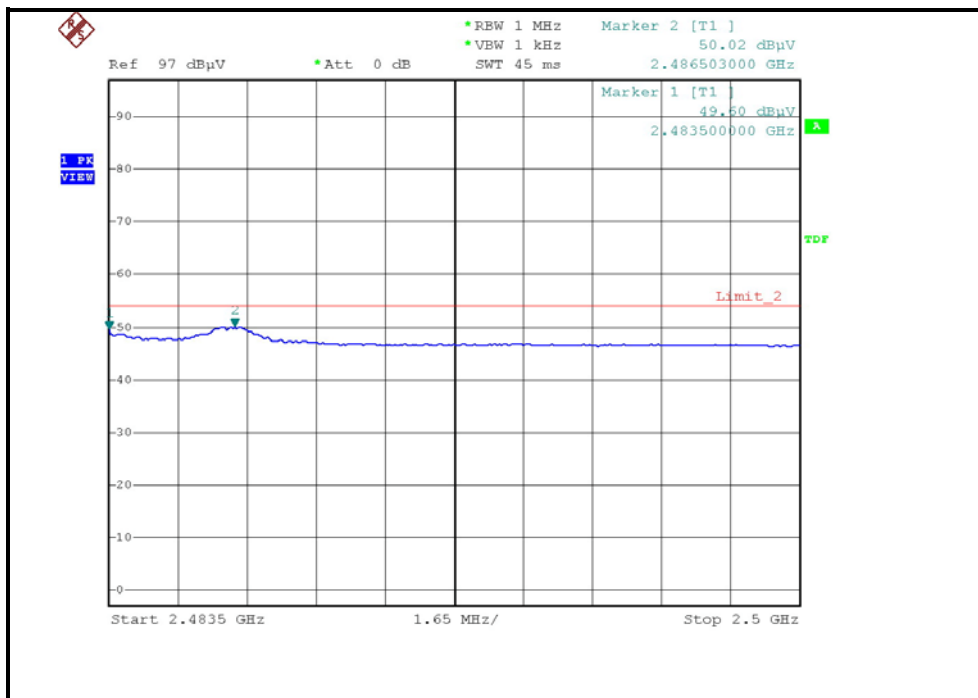
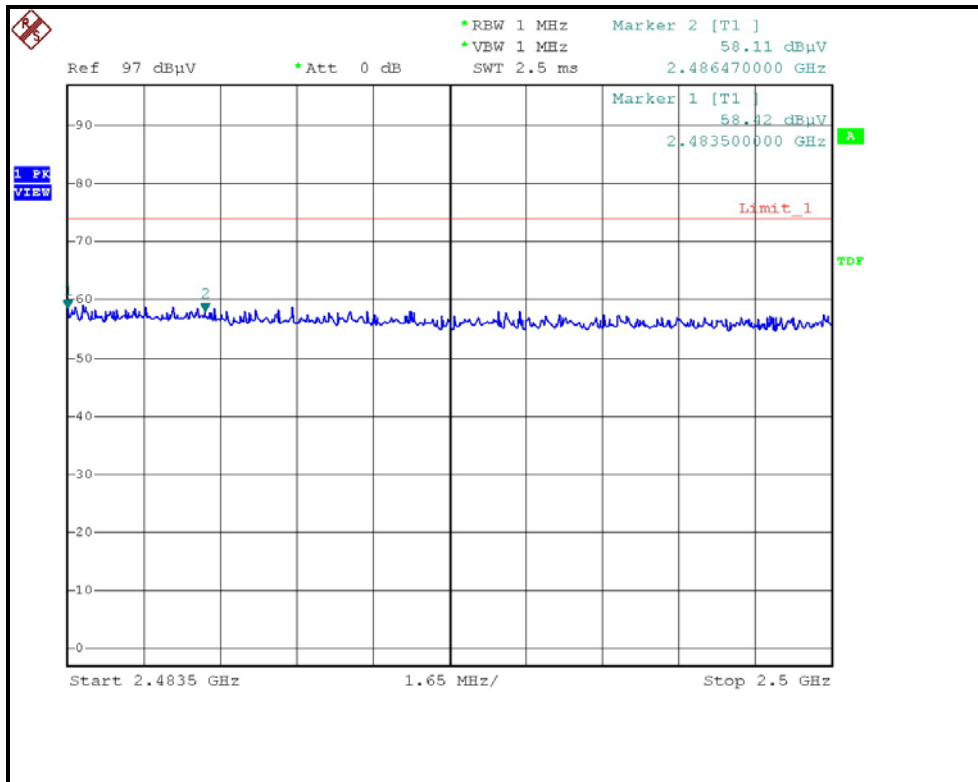



RESTRICTED BANDEDGE (802.11g MODE, CH11, VERTICAL )

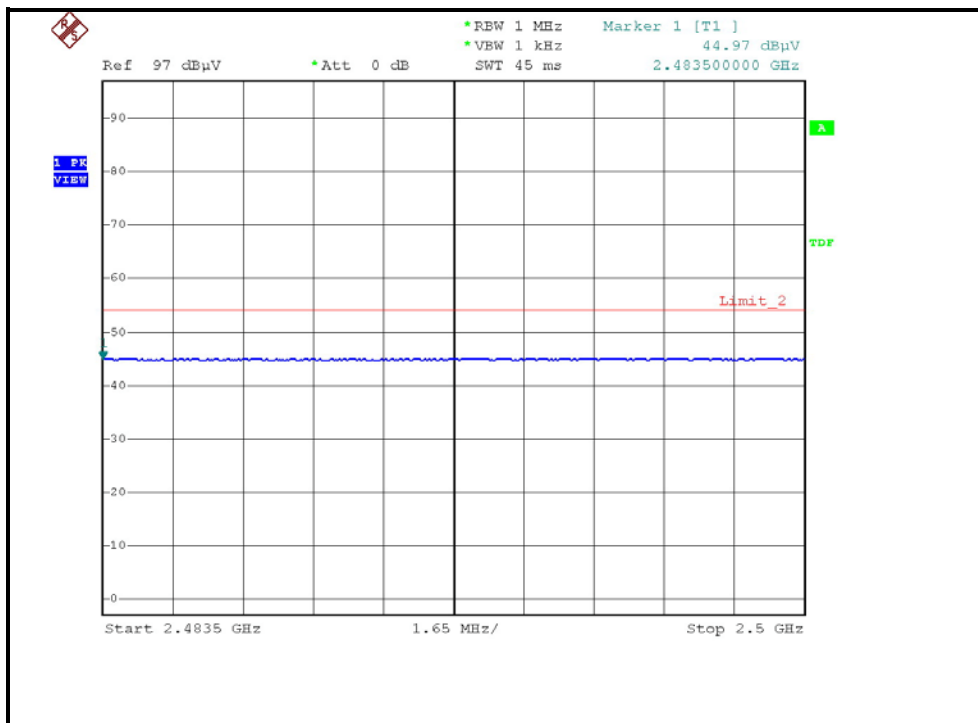
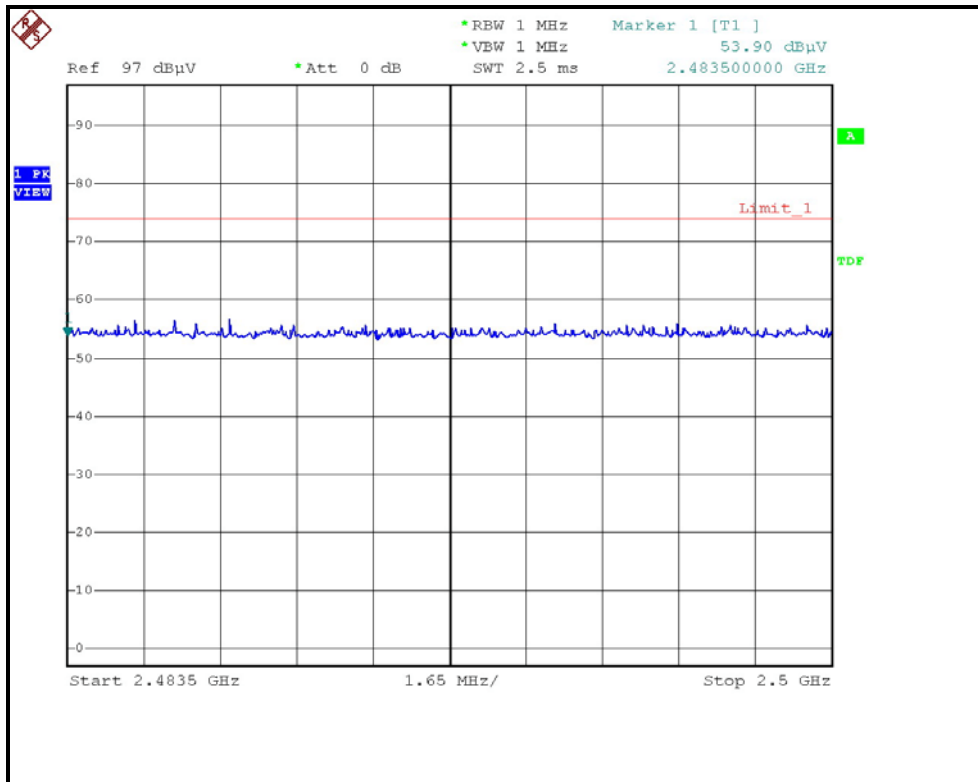

**DRAFT 802.11n (20MHz) OFDM MODULATION: DUAL TX:**

EUT TEST CONDITION		MEASUREMENT DETAIL	
CHANNEL	Channel 1	FREQUENCY RANGE	1 ~ 25GHz
MODULATION TYPE	BPSK	INPUT POWER (SYSTEM)	120Vac, 60 Hz
TRANSFER RATE	6.5Mbps	DETECTOR FUNCTION	Peak(PK) Average (AV)
ENVIRONMENTAL CONDITIONS	18deg. C, 65%RH, 964hPa	TESTED BY	Eric Lee

ANTENNA POLARITY & TEST DISTANCE: HORIZONTAL AT 3 M								
NO.	FREQ. (MHz)	EMISSION LEVEL (dBuV/m)	LIMIT (dBuV/m)	MARGIN (dB)	ANTENNA HEIGHT (m)	TABLE ANGLE (Degree)	RAW VALUE (dBuV)	CORRECTION FACTOR (dB/m)
1	2387.00	67.40 PK	74.00	-6.60	1.00 H	1	35.90	31.50
1	2387.00	52.10 AV	54.00	-1.90	1.00 H	1	20.60	31.50
2	2390.00	69.10 PK	74.00	-4.90	1.00 H	1	37.59	31.51
2	2390.00	51.70 AV	54.00	-2.30	1.00 H	1	20.19	31.51
3	*2412.00	113.60 PK			1.00 H	1	82.02	31.58
3	*2412.00	106.40 AV			1.00 H	1	74.82	31.58
4	3216.00	49.90 PK	74.00	-24.10	1.17 H	301	16.67	33.23
4	3216.00	46.10 AV	54.00	-7.90	1.17 H	301	12.87	33.23
5	4824.00	47.10 PK	74.00	-26.90	1.26 H	358	10.14	36.96
5	4824.00	45.20 AV	54.00	-8.80	1.26 H	358	8.24	36.96
6	7236.00	51.40 PK	74.00	-22.60	1.31 H	288	8.40	43.00
6	7236.00	39.30 AV	54.00	-14.70	1.31 H	288	-3.70	43.00

ANTENNA POLARITY & TEST DISTANCE: VERTICAL AT 3 M								
NO.	FREQ. (MHz)	EMISSION LEVEL (dBuV/m)	LIMIT (dBuV/m)	MARGIN (dB)	ANTENNA HEIGHT (m)	TABLE ANGLE (Degree)	RAW VALUE (dBuV)	CORRECTION FACTOR (dB/m)
1	2390.00	57.80 PK	74.00	-16.20	1.00 V	109	26.29	31.51
1	2390.00	46.70 AV	54.00	-7.30	1.00 V	109	15.19	31.51
2	*2412.00	104.50 PK			1.16 V	113	72.92	31.58
2	*2412.00	94.10 AV			1.16 V	113	62.52	31.58
3	3216.00	49.30 PK	74.00	-24.70	1.17 V	1	16.07	33.23
3	3216.00	45.60 AV	54.00	-8.40	1.17 V	1	12.37	33.23
4	4824.00	48.40 PK	74.00	-25.60	1.05 V	11	11.44	36.96
4	4824.00	44.10 AV	54.00	-9.90	1.05 V	11	7.14	36.96
5	7236.00	50.70 PK	74.00	-23.30	1.26 V	217	7.70	43.00
5	7236.00	38.40 AV	54.00	-15.60	1.26 V	217	-4.60	43.00

- REMARKS:**
1. Emission level (dBuV/m) = Raw Value (dBuV) + Correction Factor (dB/m).
  2. Correction Factor (dB/m) = Antenna Factor (dB/m) + Cable Factor (dB).
  3. The other emission levels were very low against the limit.
  4. Margin value = Emission level – Limit value.
  5. The limit value is defined as per 15.247.
  6. “ \* ”: Fundamental frequency.

EUT TEST CONDITION		MEASUREMENT DETAIL	
CHANNEL	Channel 6	FREQUENCY RANGE	1 ~ 25GHz
MODULATION TYPE	BPSK	INPUT POWER (SYSTEM)	120Vac, 60 Hz
TRANSFER RATE	6.5Mbps	DETECTOR FUNCTION	Peak(PK) Average (AV)
ENVIRONMENTAL CONDITIONS	18deg. C, 65%RH, 964hPa	TESTED BY	Eric Lee

ANTENNA POLARITY & TEST DISTANCE: HORIZONTAL AT 3 M								
NO.	FREQ. (MHz)	EMISSION LEVEL (dBuV/m)	LIMIT (dBuV/m)	MARGIN (dB)	ANTENNA HEIGHT (m)	TABLE ANGLE (Degree)	RAW VALUE (dBuV)	CORRECTION FACTOR (dB/m)
1	*2437.00	114.20 PK			1.03 H	2	82.54	31.66
1	*2437.00	107.10 AV			1.03 H	2	75.44	31.66
2	3249.00	48.20 PK	74.00	-25.80	1.18 H	64	14.88	33.32
2	3249.00	45.70 AV	54.00	-8.30	1.18 H	64	12.38	33.32
3	4874.00	48.60 PK	74.00	-25.40	1.31 H	359	11.45	37.15
3	4874.00	46.30 AV	54.00	-7.70	1.31 H	359	9.15	37.15
4	7311.00	51.10 PK	74.00	-22.90	1.29 H	304	8.01	43.09
4	7311.00	38.90 AV	54.00	-15.10	1.29 H	304	-4.19	43.09

ANTENNA POLARITY & TEST DISTANCE: VERTICAL AT 3 M								
NO.	FREQ. (MHz)	EMISSION LEVEL (dBuV/m)	LIMIT (dBuV/m)	MARGIN (dB)	ANTENNA HEIGHT (m)	TABLE ANGLE (Degree)	RAW VALUE (dBuV)	CORRECTION FACTOR (dB/m)
1	*2437.00	105.60 PK			1.19 V	20	73.94	31.66
1	*2437.00	95.10 AV			1.19 V	20	63.44	31.66
2	3249.00	50.20 PK	74.00	-23.80	1.20 V	6	16.88	33.32
2	3249.00	44.80 AV	54.00	-9.20	1.20 V	6	11.48	33.32
3	4874.00	49.60 PK	74.00	-24.40	1.09 V	120	12.45	37.15
3	4874.00	43.20 AV	54.00	-10.80	1.09 V	120	6.05	37.15
4	7311.00	50.80 PK	74.00	-23.20	1.25 V	234	7.71	43.09
4	7311.00	38.60 AV	54.00	-15.40	1.25 V	234	-4.49	43.09

- REMARKS:**
1. Emission level (dBuV/m) = Raw Value (dBuV) + Correction Factor (dB/m).
  2. Correction Factor (dB/m) = Antenna Factor (dB/m) + Cable Factor (dB).
  3. The other emission levels were very low against the limit.
  4. Margin value = Emission level – Limit value.
  5. The limit value is defined as per 15.247.
  6. “ \* “: Fundamental frequency.

EUT TEST CONDITION		MEASUREMENT DETAIL	
CHANNEL	Channel 11	FREQUENCY RANGE	1 ~ 25GHz
MODULATION TYPE	BPSK	INPUT POWER (SYSTEM)	120Vac, 60 Hz
TRANSFER RATE	6.5Mbps	DETECTOR FUNCTION	Peak(PK) Average (AV)
ENVIRONMENTAL CONDITIONS	18deg. C, 65%RH, 964hPa	TESTED BY	Eric Lee

ANTENNA POLARITY & TEST DISTANCE: HORIZONTAL AT 3 M								
NO.	FREQ. (MHz)	EMISSION LEVEL (dBuV/m)	LIMIT (dBuV/m)	MARGIN (dB)	ANTENNA HEIGHT (m)	TABLE ANGLE (Degree)	RAW VALUE (dBuV)	CORRECTION FACTOR (dB/m)
1	*2462.00	111.40 PK			1.00 H	344	79.66	31.74
1	*2462.00	106.20 AV			1.00 H	344	74.46	31.74
2	2483.50	68.60 PK	74.00	-5.40	1.00 H	344	36.79	31.81
2	2483.50	53.30 AV	54.00	-0.70	1.00 H	344	21.49	31.81
3	2486.00	62.50 PK	74.00	-11.50	1.00 H	344	30.68	31.82
3	2486.00	51.90 AV	54.00	-2.10	1.00 H	344	20.08	31.82
4	3282.00	48.40 PK	74.00	-25.60	1.02 H	1	14.98	33.42
4	3282.00	44.50 AV	54.00	-9.50	1.02 H	1	11.08	33.42
5	4924.00	48.90 PK	74.00	-25.10	1.05 H	352	11.61	37.29
5	4924.00	41.80 AV	54.00	-12.20	1.05 H	352	4.51	37.29
6	7386.00	51.40 PK	74.00	-22.60	1.34 H	321	8.02	43.38
6	7386.00	39.20 AV	54.00	-14.80	1.34 H	321	-4.18	43.38

ANTENNA POLARITY & TEST DISTANCE: VERTICAL AT 3 M								
NO.	FREQ. (MHz)	EMISSION LEVEL (dBuV/m)	LIMIT (dBuV/m)	MARGIN (dB)	ANTENNA HEIGHT (m)	TABLE ANGLE (Degree)	RAW VALUE (dBuV)	CORRECTION FACTOR (dB/m)
1	*2462.00	104.90 PK			1.19 V	140	73.16	31.74
1	*2462.00	95.30 AV			1.19 V	140	63.56	31.74
2	2483.50	53.40 PK	74.00	-20.60	1.19 V	140	21.59	31.81
2	2483.50	45.10 AV	54.00	-8.90	1.19 V	140	13.29	31.81
3	3282.00	48.50 PK	74.00	-25.50	1.00 V	331	15.08	33.42
3	3282.00	44.90 AV	54.00	-9.10	1.00 V	331	11.48	33.42
4	4924.00	47.90 PK	74.00	-26.10	4.00 V	320	10.61	37.29
4	4924.00	40.10 AV	54.00	-13.90	4.00 V	320	2.81	37.29
5	7386.00	50.90 PK	74.00	-23.10	1.24 V	243	7.52	43.38
5	7386.00	38.80 AV	54.00	-15.20	1.24 V	243	-4.58	43.38

- REMARKS:**
1. Emission level (dBuV/m) = Raw Value (dBuV) + Correction Factor (dB/m).
  2. Correction Factor (dB/m) = Antenna Factor (dB/m) + Cable Factor (dB).
  3. The other emission levels were very low against the limit.
  4. Margin value = Emission level – Limit value.
  5. The limit value is defined as per 15.247.
  6. “ \* “: Fundamental frequency.

RESTRICTED BANDEDGE (DRAFT 802.11n (20MHz) MODE, CH1, HORIZONTAL )

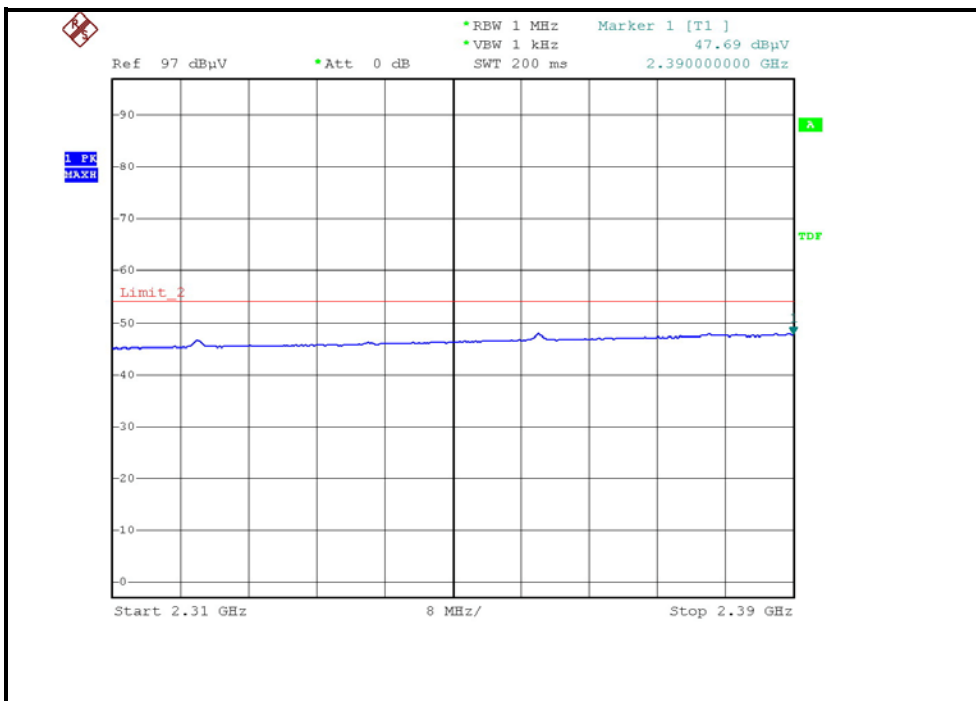
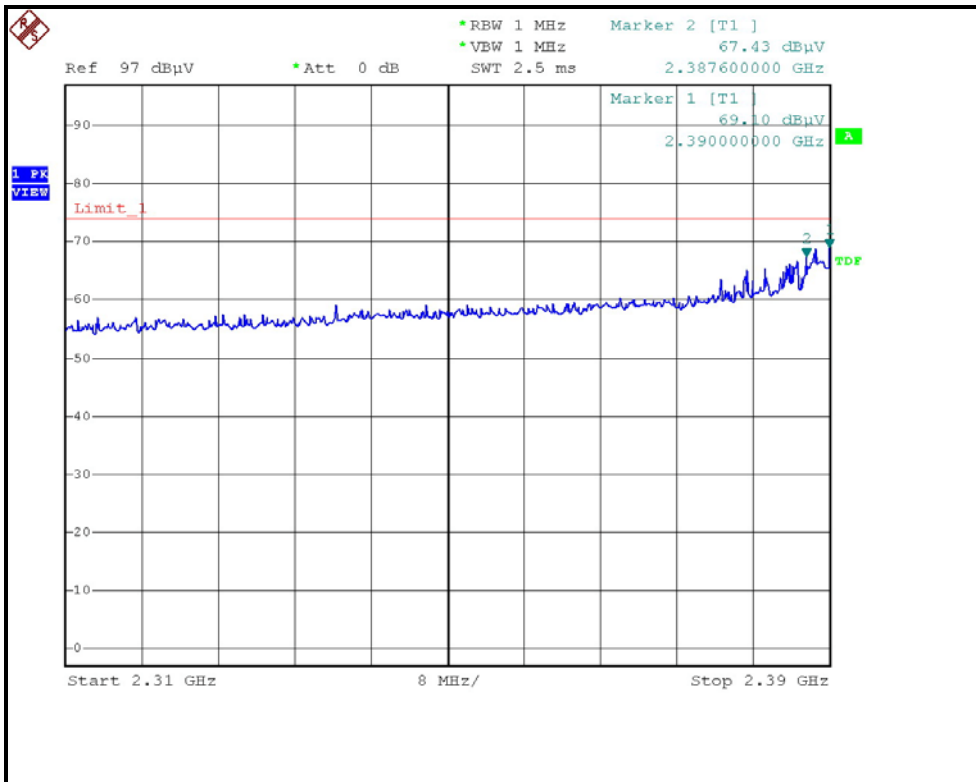

RESTRICTED BANDEDGE (DRAFT 802.11n (20MHz) MODE, CH1, VERTICAL )

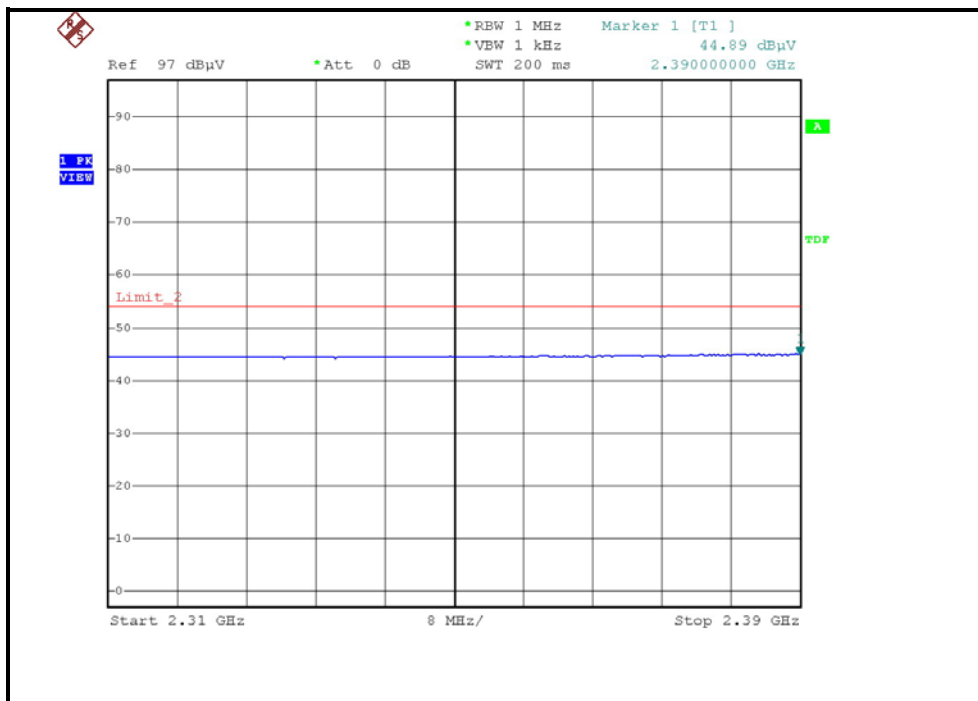
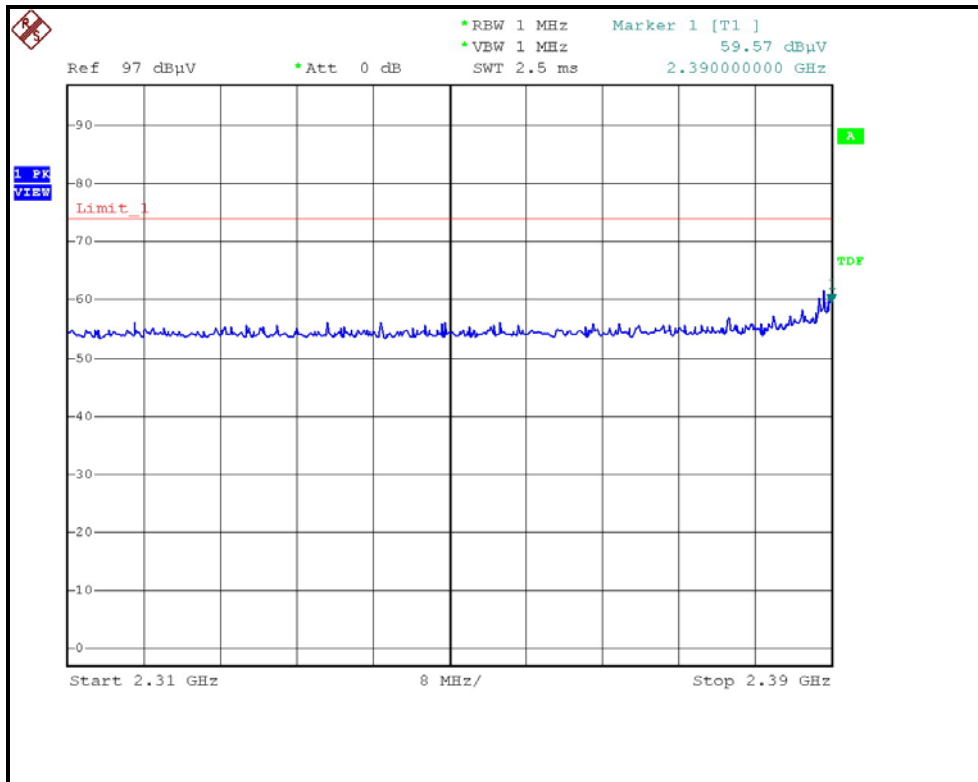

RESTRICTED BANDEDGE (DRAFT 802.11n (20MHz) MODE, CH11, HORIZONTAL )

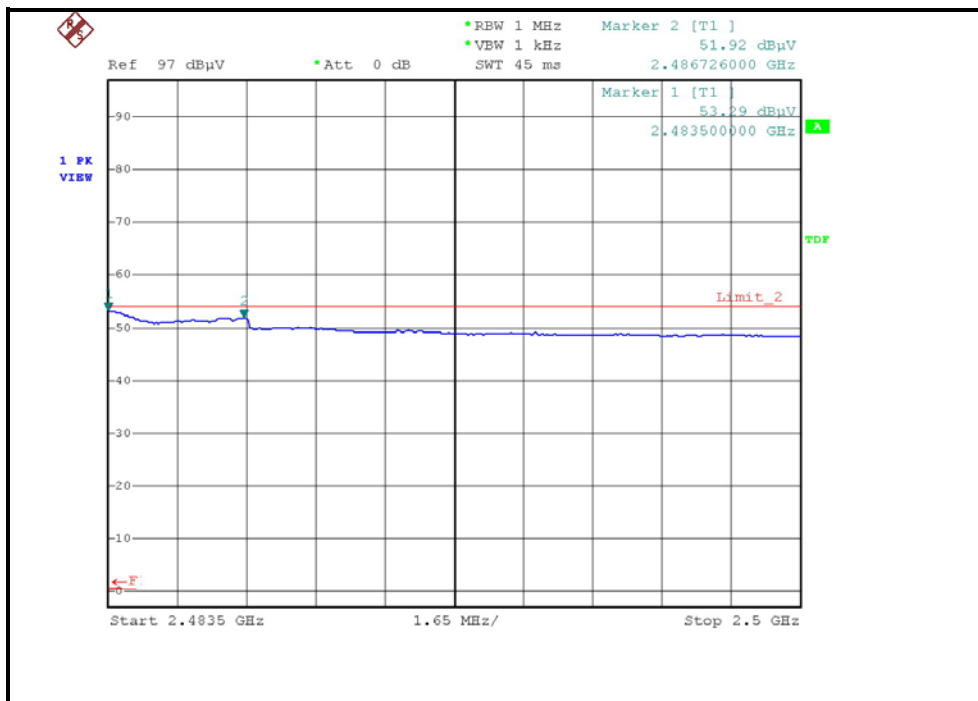
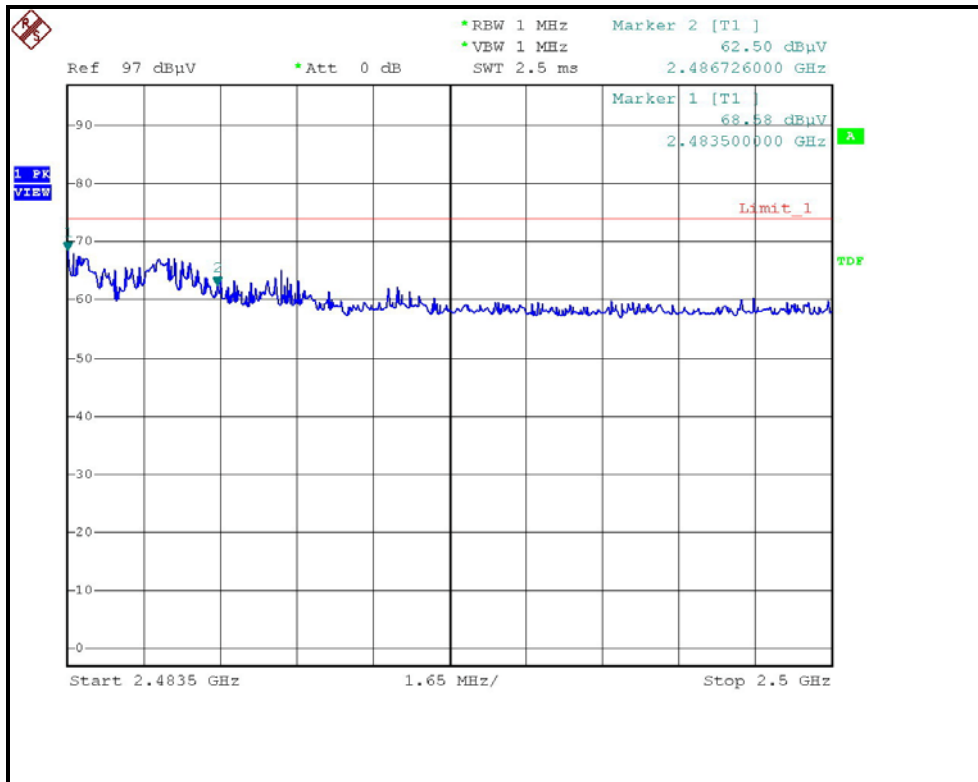

RESTRICTED BANDEDGE (DRAFT 802.11n (20MHz) MODE, CH11, VERTICAL )

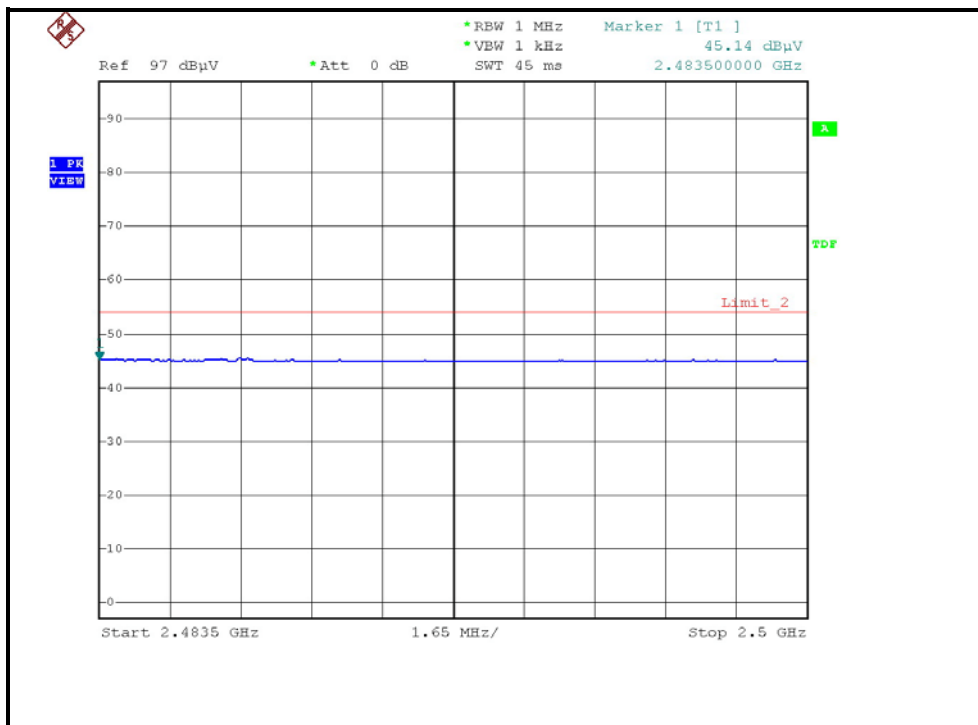
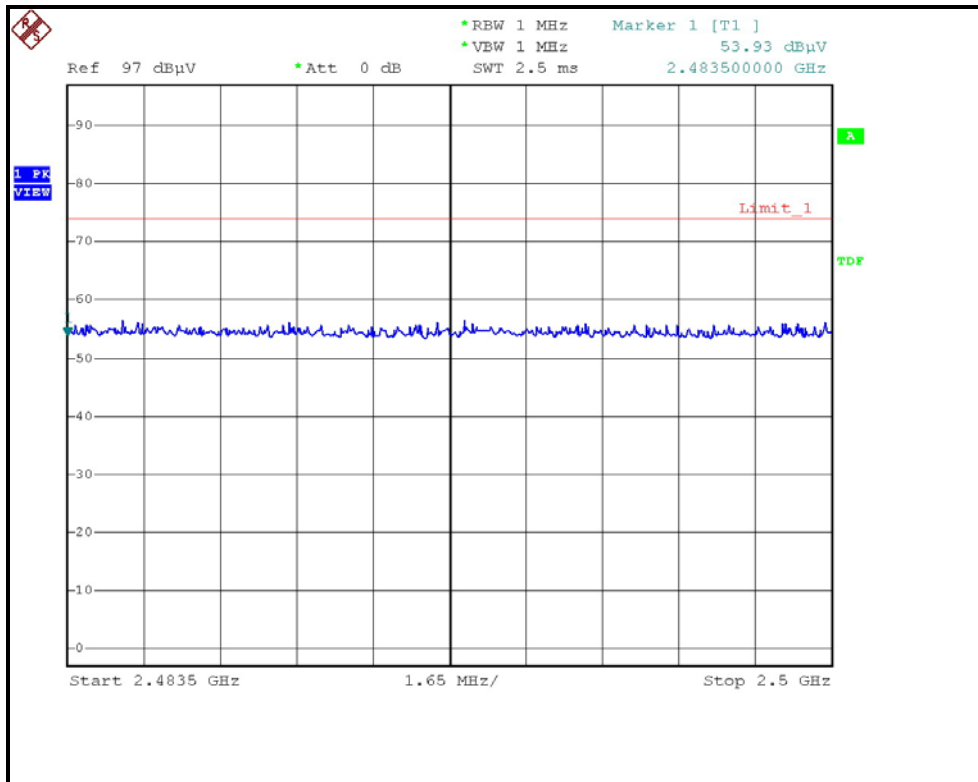



### DRAFT 802.11n (40MHz) OFDM MODULATION: DUAL TX:

EUT TEST CONDITION		MEASUREMENT DETAIL	
CHANNEL	Channel 1	FREQUENCY RANGE	1 ~ 25GHz
MODULATION TYPE	BPSK	INPUT POWER (SYSTEM)	120Vac, 60 Hz
TRANSFER RATE	13.5Mbps	DETECTOR FUNCTION	Peak(PK) Average (AV)
ENVIRONMENTAL CONDITIONS	25deg. C, 64%RH, 964hPa	TESTED BY	Wen Yu

#### ANTENNA POLARITY & TEST DISTANCE: HORIZONTAL AT 3 M

NO.	FREQ. (MHz)	EMISSION LEVEL (dBuV/m)	LIMIT (dBuV/m)	MARGIN (dB)	ANTENNA HEIGHT (m)	TABLE ANGLE (Degree)	RAW VALUE (dBuV)	CORRECTION FACTOR (dB/m)
1	2390.00	73.00 PK	74.00	-1.00	1.70 H	180	42.70	30.30
1	2390.00	52.60 AV	54.00	-1.40	1.70 H	180	22.30	30.30
2	*2422.00	110.30 PK			1.70 H	180	79.90	30.40
2	*2422.00	97.80 AV			1.70 H	180	67.30	30.40
3	3229.00	48.70 PK	74.00	-25.30	1.19 H	172	16.40	32.30
3	3229.00	45.80 AV	54.00	-8.20	1.19 H	172	13.50	32.30
4	4844.00	46.80 PK	74.00	-27.20	1.16 H	278	11.00	35.80
4	4844.00	37.60 AV	54.00	-16.40	1.16 H	278	1.80	35.80
5	7266.00	53.20 PK	74.00	-20.80	1.25 H	336	11.90	41.30
5	7266.00	41.80 AV	54.00	-12.20	1.25 H	336	0.50	41.30

#### ANTENNA POLARITY & TEST DISTANCE: VERTICAL AT 3 M

NO.	FREQ. (MHz)	EMISSION LEVEL (dBuV/m)	LIMIT (dBuV/m)	MARGIN (dB)	ANTENNA HEIGHT (m)	TABLE ANGLE (Degree)	RAW VALUE (dBuV)	CORRECTION FACTOR (dB/m)
1	2390.00	60.20 PK	74.00	-13.80	1.10 V	312	29.90	30.30
1	2390.00	44.10 AV	54.00	-9.90	1.10 V	312	13.80	30.30
2	*2422.00	98.90 PK			1.10 V	312	68.50	30.40
2	*2422.00	86.40 AV			1.10 V	312	56.00	30.40
3	3229.00	46.20 PK	74.00	-27.80	1.03 V	254	13.90	32.30
3	3229.00	39.00 AV	54.00	-15.00	1.03 V	254	6.70	32.30
4	4844.00	49.40 PK	74.00	-24.60	1.09 V	165	13.70	35.80
4	4844.00	43.80 AV	54.00	-10.20	1.09 V	165	8.00	35.80
5	7266.00	53.40 PK	74.00	-20.60	1.12 V	225	12.10	41.30
5	7266.00	42.20 AV	54.00	-11.80	1.12 V	225	0.90	41.30

- REMARKS:**
1. Emission level (dBuV/m) = Raw Value (dBuV) + Correction Factor (dB/m).
  2. Correction Factor (dB/m) = Antenna Factor (dB/m) + Cable Factor (dB).
  3. The other emission levels were very low against the limit.
  4. Margin value = Emission level – Limit value.
  5. The limit value is defined as per 15.247.
  6. “ \* “: Fundamental frequency.

EUT TEST CONDITION		MEASUREMENT DETAIL	
CHANNEL	Channel 4	FREQUENCY RANGE	1 ~ 25GHz
MODULATION TYPE	BPSK	INPUT POWER (SYSTEM)	120Vac, 60 Hz
TRANSFER RATE	13.5Mbps	DETECTOR FUNCTION	Peak(PK) Average (AV)
ENVIRONMENTAL CONDITIONS	25deg. C, 64%RH, 964hPa	TESTED BY	Wen Yu

ANTENNA POLARITY & TEST DISTANCE: HORIZONTAL AT 3 M								
NO.	FREQ. (MHz)	EMISSION LEVEL (dBuV/m)	LIMIT (dBuV/m)	MARGIN (dB)	ANTENNA HEIGHT (m)	TABLE ANGLE (Degree)	RAW VALUE (dBuV)	CORRECTION FACTOR (dB/m)
1	*2437.00	110.20 PK			1.69 H	186	79.80	30.50
1	*2437.00	98.10 AV			1.69 H	186	67.60	30.50
2	3249.00	48.90 PK	74.00	-25.10	1.04 H	169	16.50	32.30
2	3249.00	45.00 AV	54.00	-9.00	1.04 H	169	12.60	32.30
3	4874.00	47.00 PK	74.00	-27.00	1.00 H	254	11.10	35.90
3	4874.00	37.50 AV	54.00	-16.50	1.00 H	254	1.60	35.90
4	7311.00	53.10 PK	74.00	-20.90	2.25 H	241	11.60	41.50
4	7311.00	42.40 AV	54.00	-11.60	2.25 H	241	0.90	41.50

ANTENNA POLARITY & TEST DISTANCE: VERTICAL AT 3 M								
NO.	FREQ. (MHz)	EMISSION LEVEL (dBuV/m)	LIMIT (dBuV/m)	MARGIN (dB)	ANTENNA HEIGHT (m)	TABLE ANGLE (Degree)	RAW VALUE (dBuV)	CORRECTION FACTOR (dB/m)
1	*2437.00	97.60 PK			1.01 V	87	67.10	30.50
1	*2437.00	86.00 AV			1.01 V	87	55.60	30.50
2	3249.00	46.50 PK	74.00	-27.50	1.03 V	253	14.20	32.30
2	3249.00	38.70 AV	54.00	-15.30	1.03 V	253	6.40	32.30
3	4874.00	48.60 PK	74.00	-25.40	1.05 V	179	12.70	35.90
3	4874.00	42.00 AV	54.00	-12.00	1.05 V	179	6.20	35.90
4	7311.00	53.00 PK	74.00	-21.00	1.13 V	354	11.60	41.50
4	7311.00	42.30 AV	54.00	-11.70	1.13 V	354	0.80	41.50

- REMARKS:**
1. Emission level (dBuV/m) = Raw Value (dBuV) + Correction Factor (dB/m).
  2. Correction Factor (dB/m) = Antenna Factor (dB/m) + Cable Factor (dB).
  3. The other emission levels were very low against the limit.
  4. Margin value = Emission level – Limit value.
  5. The limit value is defined as per 15.247.
  6. “ \* “: Fundamental frequency.

EUT TEST CONDITION		MEASUREMENT DETAIL	
CHANNEL	Channel 7	FREQUENCY RANGE	1 ~ 25GHz
MODULATION TYPE	BPSK	INPUT POWER (SYSTEM)	120Vac, 60 Hz
TRANSFER RATE	13.5Mbps	DETECTOR FUNCTION	Peak(PK) Average (AV)
ENVIRONMENTAL CONDITIONS	18deg. C, 65%RH, 964hPa	TESTED BY	Eric Lee

ANTENNA POLARITY & TEST DISTANCE: HORIZONTAL AT 3 M								
NO.	FREQ. (MHz)	EMISSION LEVEL (dBuV/m)	LIMIT (dBuV/m)	MARGIN (dB)	ANTENNA HEIGHT (m)	TABLE ANGLE (Degree)	RAW VALUE (dBuV)	CORRECTION FACTOR (dB/m)
1	*2452.00	109.60 PK			1.12 H	173	79.00	30.60
1	*2452.00	97.30 AV			1.12 H	173	66.70	30.60
2	2483.50	70.50 PK	74.00	-3.50	1.12 H	173	39.80	30.70
2	2483.50	53.30 AV	54.00	-0.70	1.12 H	173	22.60	30.70
3	3269.00	46.60 PK	74.00	-27.40	1.26 H	107	14.30	32.30
3	3269.00	41.00 AV	54.00	-13.00	1.26 H	107	8.60	32.30
4	4904.00	46.70 PK	74.00	-27.30	1.27 H	285	10.80	36.00
4	4904.00	36.80 AV	54.00	-17.20	1.27 H	285	0.90	36.00
5	7356.00	53.50 PK	74.00	-20.50	1.11 H	325	12.00	41.60
5	7356.00	42.10 AV	54.00	-11.90	1.11 H	325	0.50	41.60

ANTENNA POLARITY & TEST DISTANCE: VERTICAL AT 3 M								
NO.	FREQ. (MHz)	EMISSION LEVEL (dBuV/m)	LIMIT (dBuV/m)	MARGIN (dB)	ANTENNA HEIGHT (m)	TABLE ANGLE (Degree)	RAW VALUE (dBuV)	CORRECTION FACTOR (dB/m)
1	*2452.00	98.50 PK			1.11 V	309	67.90	30.60
1	*2452.00	86.00 AV			1.11 V	309	55.40	30.60
2	2483.50	60.00 PK	74.00	-14.00	1.11 V	309	29.30	30.70
2	2483.50	45.60 AV	54.00	-8.40	1.11 V	309	14.90	30.70
3	3269.00	45.40 PK	74.00	-28.60	1.09 V	346	13.10	32.30
3	3269.00	37.30 AV	54.00	-16.70	1.09 V	346	5.00	32.30
4	4904.00	47.30 PK	74.00	-26.70	1.13 V	32	11.30	36.00
4	4904.00	37.70 AV	54.00	-16.30	1.13 V	32	1.70	36.00
5	7356.00	53.50 PK	74.00	-20.50	1.35 V	225	11.90	41.60
5	7356.00	42.40 AV	54.00	-11.60	1.35 V	225	0.80	41.60

- REMARKS:**
1. Emission level (dBuV/m) = Raw Value (dBuV) + Correction Factor (dB/m).
  2. Correction Factor (dB/m) = Antenna Factor (dB/m) + Cable Factor (dB).
  3. The other emission levels were very low against the limit.
  4. Margin value = Emission level – Limit value.
  5. The limit value is defined as per 15.247.
  6. “ \* “: Fundamental frequency.







