

Title			CyberTAN
Size	Document Number	Rev	
B	WET11 v2	XB	
Date:	Tuesday, July 22, 2003	Sheet	1 of 4

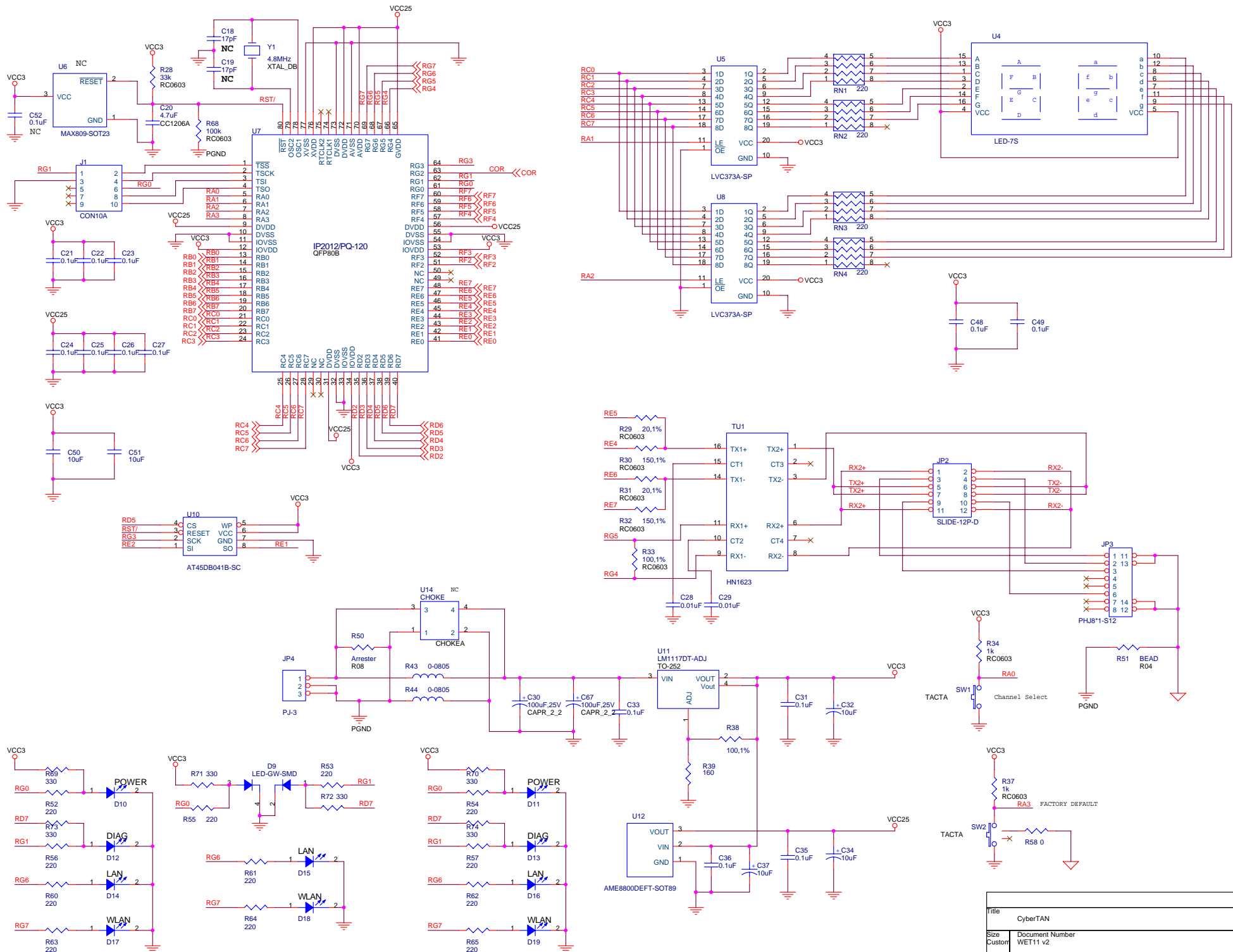

Title		CyberTAN
Size	Document Number	Rev
Custom	WET11 v2	XB
Date:	Tuesday, July 22, 2003	Sheet 2 of 4

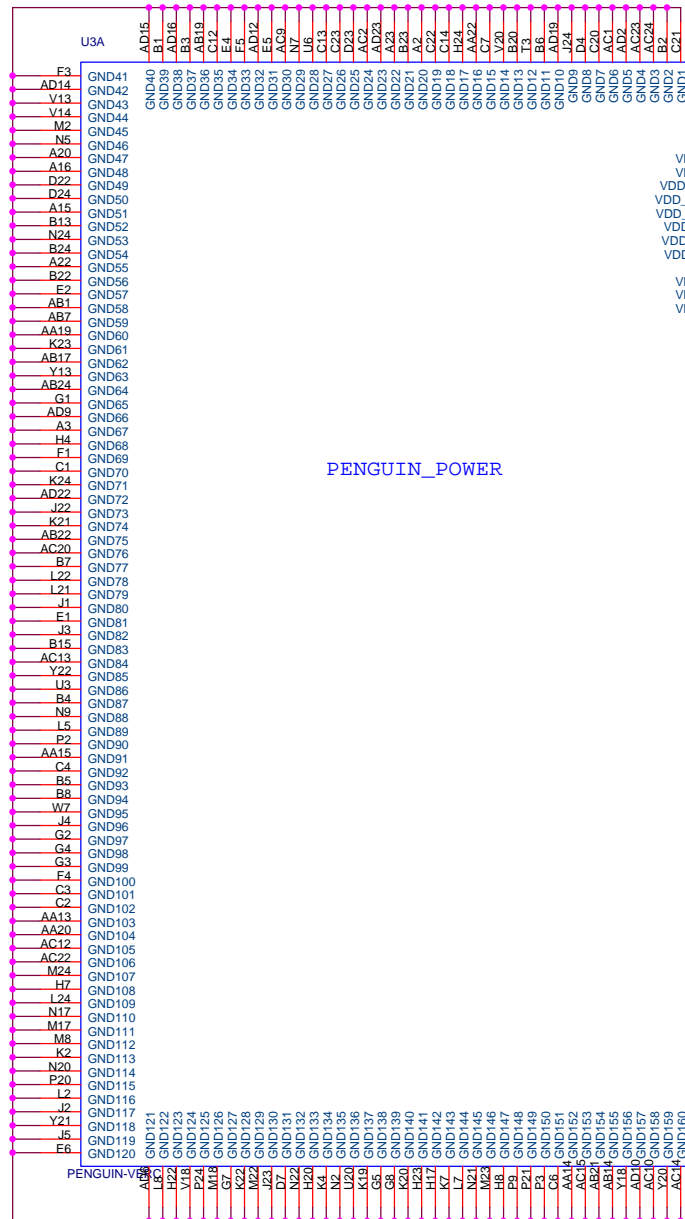

PENGUIN\_POWER

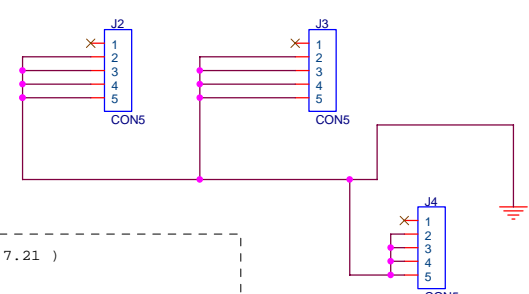
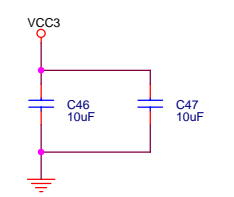
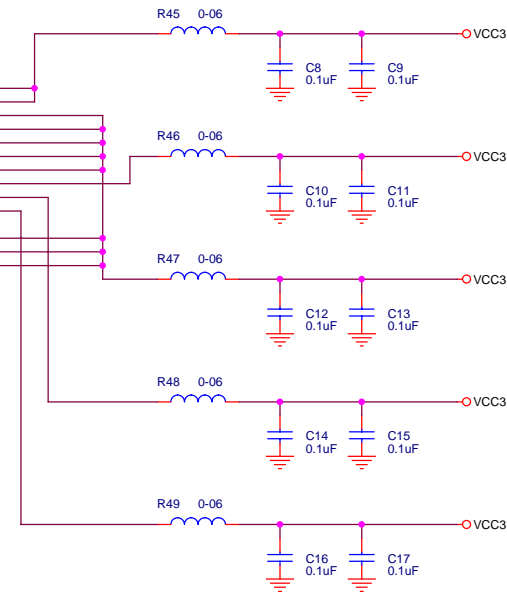
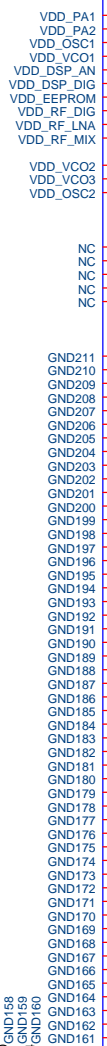

REMARK: (XA to XB 2003.7.21 )

- 1.Add H/W Power LED
- 2.Add RD7 to DIAG LED
- 3.Add R68 100K 0603 Connect RST/ to GND(for ESD)
- 4.Resize J3 to fit generic housing
- 5.Re-layout DCIN part to for ESD

Title		CyberTAN
Size	Document Number	Rev
B	WET11 v2	XB
Date:	Tuesday, July 22, 2003	Sheet 3 of 4

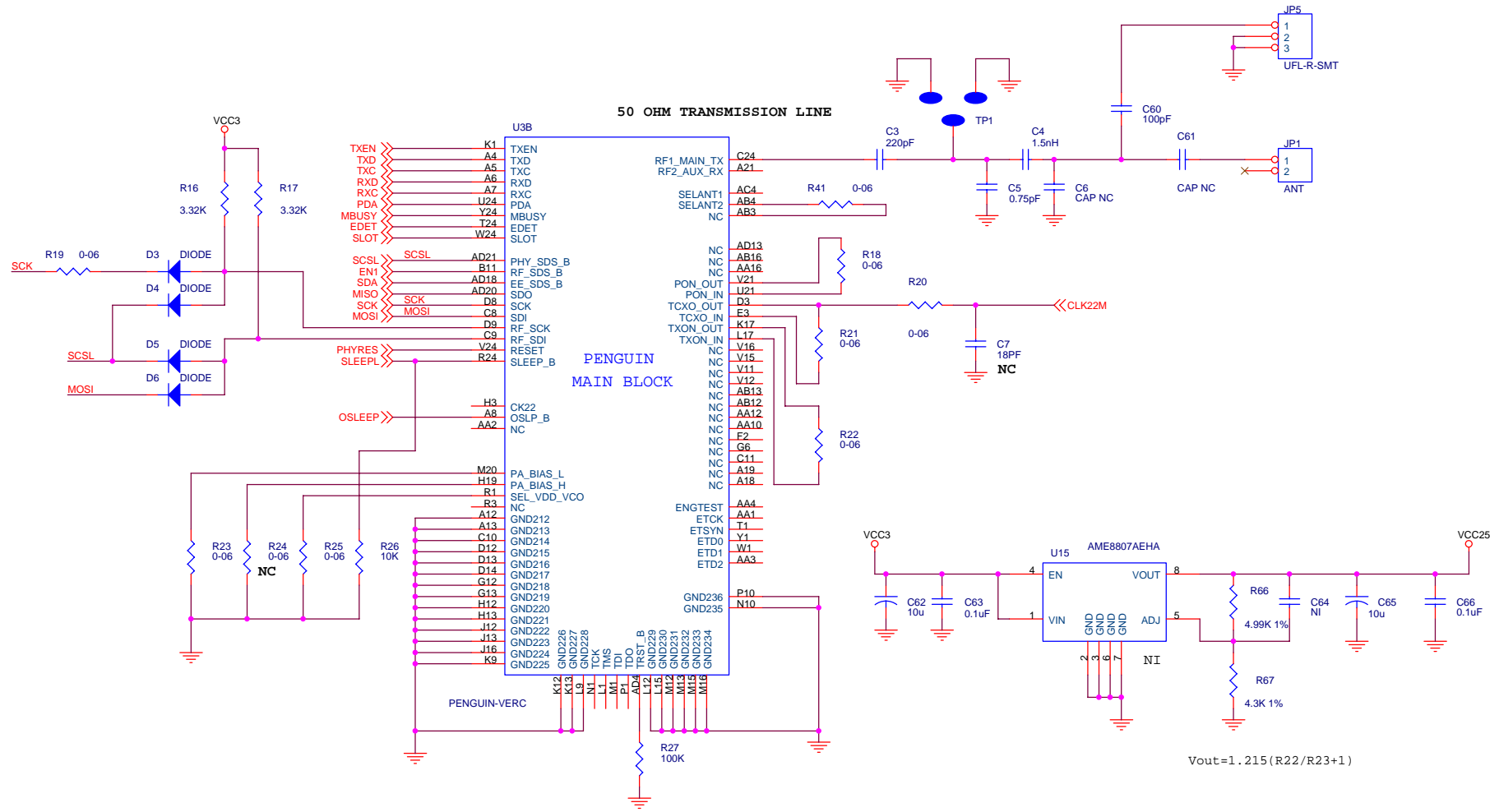

$$V_{out} = 1.215 \left( \frac{R22}{R23} + 1 \right)$$

Title		
CyberTAN		
Size	Document Number	Rev
B	WET11 v2	XB
Date:	Tuesday, July 22, 2003	Sheet 4 of 4