



FCC TEST REPORT (15.407)

REPORT NO.: RF971120H03D-1

MODEL NO.: E2000

RECEIVED: Nov. 20, 2008

TESTED: Dec. 22 to 23, 2008 & April 16 to 17, 2009

ISSUED: Dec. 18, 2009

APPLICANT: Cisco-Linksys LLC

ADDRESS: 121 Theory Drive Irvine, CA 92617(USA)

ISSUED BY: Bureau Veritas Consumer Products Services
(H.K.) Ltd., Taoyuan Branch

TEST LOCATION: No. 81-1, Lu Liao Keng, 9th Ling, Wu Lung
Tsuen, Chiung Lin Hsiang, Hsin Chu Hsien
307, Taiwan

This test report consists of 117 pages in total. It may be duplicated completely for legal use with the approval of the applicant. It should not be reproduced except in full, without the written approval of our laboratory. The client should not use it to claim product endorsement by TAF or any government agencies. The test results in the report only apply to the tested sample.



Table of Contents

1.	CERTIFICATION	4
2.	SUMMARY OF TEST RESULTS	5
2.1	MEASUREMENT UNCERTAINTY	6
3.	GENERAL INFORMATION	7
3.1	GENERAL DESCRIPTION OF EUT	7
3.2	DESCRIPTION OF TEST MODES	10
3.2.1	TEST MODE APPLICABILITY AND TESTED CHANNEL DETAIL:	11
3.3	GENERAL DESCRIPTION OF APPLIED STANDARDS	14
3.4	DESCRIPTION OF SUPPORT UNITS.....	15
3.5	CONFIGURATION OF SYSTEM UNDER TEST	16
4.	TEST TYPES AND RESULTS	18
4.1	CONDUCTED EMISSION MEASUREMENT	18
4.1.1	LIMITS OF CONDUCTED EMISSION MEASUREMENT	18
4.1.2	TEST INSTRUMENTS.....	18
4.1.3	TEST PROCEDURES	19
4.1.4	DEVIATION FROM TEST STANDARD	19
4.1.5	TEST SETUP	20
4.1.6	EUT OPERATING CONDITIONS	21
4.1.7	TEST RESULTS-ADAPTER 1	22
4.1.8	TEST RESULTS-ADAPTER 2	24
4.2	RADIATED EMISSION MEASUREMENT	26
4.2.1	LIMITS OF RADIATED EMISSION MEASUREMENT.....	26
4.2.2	LIMITS OF UNWANTED EMISSION OUT OF THE RESTRICTED BANDS.....	27
4.2.3	TEST INSTRUMENTS.....	28
4.2.4	TEST PROCEDURES	30
4.2.5	DEVIATION FROM TEST STANDARD	30
4.2.6	TEST SETUP	31
4.2.7	EUT OPERATING CONDITION.....	31
	BELOW 1GHZ TEST DATA.....	32
4.2.8	TEST RESULTS-ADAPTER 1	32
4.2.9	TEST RESULTS-ADAPTER 2	33
	ABOVE 1GHZ TEST DATA	34
4.2.10	TEST RESULTS	34
4.3	PEAK TRANSMIT POWER MEASUREMENT	54
4.3.1	LIMITS OF PEAK TRANSMIT POWER MEASUREMENT	54
4.3.2	TEST INSTRUMENTS.....	54
4.3.3	TEST PROCEDURE.....	55
4.3.4	DEVIATION FROM TEST STANDARD	55
4.3.5	TEST SETUP	55



4.3.6	EUT OPERATING CONDITIONS	55
4.3.7	TEST RESULTS	56
4.4	PEAK POWER EXCURSION MEASUREMENT	75
4.4.1	LIMITS OF PEAK POWER EXCURSION MEASUREMENT	75
4.4.2	TEST INSTRUMENTS.....	75
4.4.3	TEST PROCEDURE.....	76
4.4.4	DEVIATION FROM TEST STANDARD	76
4.4.5	TEST SETUP	76
4.4.6	EUT OPERATING CONDITIONS	76
4.4.7	TEST RESULTS	77
4.5	PEAK POWER SPECTRAL DENSITY MEASUREMENT	88
4.5.1	LIMITS OF PEAK POWER SPECTRAL DENSITY MEASUREMENT	88
4.5.2	TEST INSTRUMENTS.....	88
4.5.3	TEST PROCEDURES	89
4.5.4	DEVIATION FROM TEST STANDARD	89
4.5.5	TEST SETUP	89
4.5.6	EUT OPERATING CONDITIONS	89
4.5.7	TEST RESULTS	90
4.6	FREQUENCY STABILITY.....	101
4.6.1	LIMITS OF FREQUENCY STABILITY MEASUREMENT	101
4.6.2	TEST INSTRUMENTS.....	101
4.6.3	TEST PROCEDURE.....	101
4.6.4	DEVIATION FROM TEST STANDARD	102
4.6.5	TEST SETUP	102
4.6.6	EUT OPERATING CONDITION.....	102
4.6.7	TEST RESULTS	103
4.7	ANTENNA PORT OUTPUT SPECTRUM PLOTS	104
4.7.1	TEST INSTRUMENTS.....	104
4.7.2	TEST PROCEDURE.....	104
4.7.3	EUT OPERATING CONDITION.....	104
4.7.4	TEST RESULTS	104
4.8	ANTENNA REQUIREMENT	115
4.8.1	STANDARD APPLICABLE.....	115
4.8.2	ANTENNA CONNECTED CONSTRUCTION.....	115
5.	INFORMATION ON THE TESTING LABORATORIES	116
6.	APPENDIX A - MODIFICATIONS RECORDERS FOR ENGINEERING CHANGES TO THE EUT BY THE LAB.....	117



1. CERTIFICATION

PRODUCT: Dual-Band Wireless-N Gigabit Router
BRAND NAME: Linksys
MODEL NO.: E2000
TEST SAMPLE: ENGINEERING SAMPLE
TESTED: Dec. 22 to 23, 2008 & April 16 to 17, 2009
APPLICANT: Cisco-Linksys LLC
STANDARDS: FCC Part 15, Subpart E (Section 15.407),
ANSI C63.4-2003

The above equipment (Model: E2000) has been tested by **Bureau Veritas Consumer Products Services (H.K.) Ltd., Taoyuan Branch**, and found compliance with the requirement of the above standards. The test record, data evaluation & Equipment Under Test (EUT) configurations represented herein are true and accurate accounts of the measurements of the sample's EMC characteristics under the conditions specified in this report.

PREPARED BY : Midoli Peng , **DATE:** Dec. 18, 2009
(Midoli Peng, Specialist)

TECHNICAL ACCEPTANCE : Hank Chung , **DATE:** Dec. 18, 2009
(Hank Chung, Deputy Manager)

APPROVED BY : May Chen , **DATE:** Dec. 18, 2009
(May Chen, Deputy Manager)

2. SUMMARY OF TEST RESULTS

The EUT has been tested according to the following specifications:

For [802.11a](#)

APPLIED STANDARD: FCC Part 15, Subpart E (Section 15.407)			
Standard Section	Test Type	Result	Remark
15.407(b)(5)	AC Power Conducted Emission	PASS	Meet the requirement of limit. Minimum passing margin is -10.15dB at 0.162MHz
15.407(b/1/2/3) (b)(5)	Electric Field Strength Spurious Emissions, 30MHz ~ 40000MHz	PASS	Meet the requirement of limit. Minimum passing margin is -0.41dB at 10360MHz
15.407(a/1/2/3)	Peak Transmit Power	PASS	Meet the requirement of limit.
15.407(a)(6)	Peak Power Excursion	PASS	Meet the requirement of limit.
15.407(a/1/2/3)	Peak Power Spectral Density	PASS	Meet the requirement of limit.
15.407(g)	Frequency Stability	PASS	Meet the requirement of limit.

NOTE:

1. The EUT was operating in 2.400 ~ 2.4835GHz, 5.15~5.25GHz and 5.725~5.85GHz frequencies band. This report was recorded the RF parameters including 5.15~5.25GHz. For the 2.400 ~ 2.4835GHz and 5.725~5.85GHz RF parameters was recorded in another test report.

2.1 MEASUREMENT UNCERTAINTY

Where relevant, the following measurement uncertainty levels have been estimated for tests performed on the EUT as specified in CISPR 16-4-2:

This uncertainty represents an expanded uncertainty expressed at approximately the 95% confidence level using a coverage factor of $k=2$.

Measurement	Value
Conducted emissions	2.45 dB
Radiated emissions (30MHz-1GHz)	3.94 dB
Radiated emissions (1GHz -18GHz)	2.49 dB
Radiated emissions (18GHz -40GHz)	2.70 dB



3. GENERAL INFORMATION

3.1 GENERAL DESCRIPTION OF EUT

PRODUCT	Dual-Band Wireless-N Gigabit Router
MODEL NO.	E2000
FCC ID	Q87-E2000
POWER SUPPLY	DC 12V from power adapter
MODULATION TYPE	CCK, DQPSK, DBPSK for DSSS 64QAM, 16QAM, QPSK, BPSK for OFDM
MODULATION TECHNOLOGY	DSSS, OFDM
TRANSFER RATE	802.11b: 11 / 5.5 / 2 / 1Mbps 802.11g: 54 / 48 / 36 / 24 / 18 / 12 / 9 / 6Mbps 802.11a: 54 / 48 / 36 / 24 / 18 / 12 / 9 / 6Mbps Draft 802.11n (20MHz): 130 / 117 / 104 / 78 / 65 / 58.5 / 52 / 39 / 26 / 19.5 / 13 / 6.5Mbps Draft 802.11n (40MHz): 270 / 243 / 216 / 162 / 135 / 121.5 / 108 / 81 / 54 / 40.5 / 27 / 13.5Mbps
FREQUENCY RANGE	For 15.407 802.11a: 5.18 ~ 5.24GHz For 15.247 802.11b & 802.11g: 2.412 ~ 2.462GHz 802.11a: 5.745 ~ 5.825GHz
NUMBER OF CHANNEL	For 15.407 4 for 802.11a, draft 802.11n (20MHz) 2 for draft 802.11n (40MHz) For 15.247(2.4GHz) 11 for 802.11b, 802.11g, draft 802.11n (20MHz) 7 for draft 802.11n (40MHz) For 15.247(5GHz) 5 for 802.11a, draft 802.11n (20MHz) 2 for draft 802.11n (40MHz)



MAXIMUM OUTPUT POWER	For 15.407 802.11a: 26.90mW draft 802.11n (20MHz): 27.0mW draft 802.11n (40MHz): 49.1mW For 15.247(2.4GHz) 802.11b: 154.9mW 802.11g: 302.0mW draft 802.11n (20MHz): 625.6mW draft 802.11n (40MHz): 663.0mW For 15.247(5GHz) 802.11a: 223.9mW draft 802.11n (20MHz): 375.2mW draft 802.11n (40MHz): 387.8mW
ANTENNA TYPE	Please see note 2
DATA CABLE	NA
I/O PORT	LAN port x 4 ,WAN port x 1
ASSOCIATED DEVICES	NA

NOTE:

1. The EUT must be supplied with a power adapter and following two different models could be chosen:

Adapter	Brand	Model No.	Spec.
Adapter 1	Bestec	EA0121WAA	Input: 100-240V, 0.5A, 50-60Hz Output: DC12V, 1A
Adapter 2	LEADER	MU12-G120100-A1	Input: 100-240V, 0.5A, 50-60Hz Output: DC12V, 1A DC output cable (unshielded, 1.5m)

2. There are three antennas provided to this EUT, please refer to the following table:

Transmitter / Circuit	Antenna Gain			Antenna Type	Connector
	For 2.4GHz Gain (dBi)	For 5.15~5.25GHz Gain (dBi)	For 5.725~5.850GHz Gain (dBi)		
Chain(0)J9	2.0	4.3	5.6	PIFA	UFL
Chain(1)J14	4.5	5.6	4.9	PIFA	UFL
Chain(2)J10	4.2	4.4	4.5	PIFA	UFL

3. For radiated test, The EUT was pre-tested under the following modes:

Test Mode	Description
Mode A	Level-set
Mode B	Tower-set

From the above modes, the radiated (below 1GHz) worst case was found in **Mode B** and the radiated (above 1GHz) worst case was found in **Mode A**. Therefore only the test data of the modes were recorded in this report.

4. The EUT incorporates a MIMO function with draft 802.11n. Physically, the EUT provides two completed transmitters and three completed receivers.
5. The EUT is 2 * 3 spatial MIMO (2Tx & 3Rx) without beam forming function. The antenna configurations are two transmitter antennas and three receiver antennas, as there are 3 PIFA antennas. Spatial multiplexing modes for simultaneous transmission using 2 antennas, and for simultaneous receiver using 3 antennas. The 11a and 11bg legacy mode is limited to single transmitter only.
6. When the EUT operating in draft 802.11n, the software operation, which is defined by manufacturer, MCS (Modulation and Coding Schemes) from 0 to 15.
7. The EUT complies with draft 802.11n standards and backwards compatible with 802.11a, 802.11b, 802.11g products.
8. The above EUT information was declared by manufacturer and for more detailed features description, please refer to the manufacturer's specifications or user's manual.

3.2 DESCRIPTION OF TEST MODES

Operated in 5150MHz ~ 5250MHz bands:

Four channels are provided for 802.11a and draft 802.11n (20MHz):

CHANNEL	FREQUENCY
1	5180 MHz
2	5200 MHz
3	5220 MHz
4	5240 MHz

Two channels are provided for draft 802.11n (40MHz):

CHANNEL	FREQUENCY
1	5190 MHz
2	5230 MHz

3.2.1 TEST MODE APPLICABILITY AND TESTED CHANNEL DETAIL:

EUT CONFIGURE MODE	APPLICABLE TO				DESCRIPTION
	PLC	RE < 1G	RE ≥ 1G	APCM	
-	√	√	√	√	-

Where **PLC**: Power Line Conducted Emission **RE < 1G**: Radiated Emission below 1GHz
RE ≥ 1G: Radiated Emission above 1GHz **APCM**: Antenna Port Conducted Measurement

ANTENNA COMBINATION MODE:

COMBINATION MODE	OPERATION MODE	CHAIN(0) (TX)	CHAIN(1) (TX)	CHAIN(2) (TX)
A	802.11a	√		
B	DRAFT 802.11n for MCS 0~15	√		√
C	DRAFT 802.11n for MCS 0~15	√	√	
D	DRAFT 802.11n for MCS 0~15		√	√

Note:

- The above information was declared by manufacturer and for more detailed features description, please refer to the manufacturer's specifications or user's manual.
- Antenna 1 ~3 are PIFA antennas.

POWER LINE CONDUCTED EMISSION TEST:

- Pre-Scan has been conducted to determine the worst-case mode from all possible combinations between available modulations, data rates and antenna ports (if EUT with antenna diversity architecture).
- Following channel(s) was (were) selected for the final test as listed below.

MODE	AVAILABLE CHANNEL	TESTED CHANNEL	MODULATION TECHNOLOGY	MODULATION TYPE	DATA RATE (Mbps)	TX COMBINATION
For 5 GHz Draft 802.11n (40MHz)	1 to 2	2	OFDM	BPSK	13.5	C

- The EUT was tested with the following test modes:

Test Mode	Description
Mode A	Adapter 1
Mode B	Adapter 2

RADIATED EMISSION TEST (BELOW 1 GHz):

- Pre-Scan has been conducted to determine the worst-case mode from all possible combinations between available modulations, data rates and antenna ports (if EUT with antenna diversity architecture).
- Following channel(s) was (were) selected for the final test as listed below.

MODE	AVAILABLE CHANNEL	TESTED CHANNEL	MODULATION TECHNOLOGY	MODULATION TYPE	DATA RATE (Mbps)	TX COMBINATION
For 5 GHz Draft 802.11n (20MHz)	1 to 4	1	OFDM	BPSK	6.5	B

- The EUT was tested with the following test modes:

Test Mode	Description
Mode A	Adapter 1
Mode B	Adapter 2

RADIATED EMISSION TEST (ABOVE 1 GHz):

- Pre-Scan has been conducted to determine the worst-case mode from all possible combinations between available modulations, data rates and antenna ports (if EUT with antenna diversity architecture).
- Following channel(s) was (were) selected for the final test as listed below.

MODE	AVAILABLE CHANNEL	TESTED CHANNEL	MODULATION TECHNOLOGY	MODULATION TYPE	DATA RATE (Mbps)	TX COMBINATION
802.11a	1 to 4	1, 2, 4	OFDM	BPSK	6	A
For 5 GHz Draft 802.11n (20MHz)	1 to 4	1, 2, 4	OFDM	BPSK	6.5	B
For 5 GHz Draft 802.11n (40MHz)	1 to 2	1, 2	OFDM	BPSK	13.5	B

ANTENNA PORT OUTPUT SPECTRUM PLOTS :

- Pre-Scan has been conducted to determine the worst-case mode from all possible combinations between available modulations, data rates and antenna ports (if EUT with antenna diversity architecture).
- Following channel(s) was (were) selected for the final test as listed below.

MODE	AVAILABLE CHANNEL	TESTED CHANNEL	MODULATION TECHNOLOGY	MODULATION TYPE	DATA RATE (Mbps)	TX COMBINATION
802.11a	1 to 4	1, 4	OFDM	BPSK	6	A
For 5 GHz Draft 802.11n (20MHz)	1 to 4	1, 4	OFDM	BPSK	13	B
For 5 GHz Draft 802.11n (40MHz)	1 to 2	1, 2	OFDM	BPSK	27	B

ANTENNA PORT CONDUCTED MEASUREMENT:

- Pre-Scan has been conducted to determine the worst-case mode from all possible combinations between available modulations, data rates and antenna ports (if EUT with antenna diversity architecture).
- Following channel(s) was (were) selected for the final test as listed below.

MODE	AVAILABLE CHANNEL	TESTED CHANNEL	MODULATION TECHNOLOGY	MODULATION TYPE	DATA RATE (Mbps)	TX COMBINATION
802.11a	1 to 4	1, 2, 4	OFDM	BPSK	6	A
For 5 GHz Draft 802.11n (20MHz)	1 to 4	1, 2, 4	OFDM	BPSK	13	C
For 5 GHz Draft 802.11n (40MHz)	1 to 2	1, 2	OFDM	BPSK	27	C

3.3 GENERAL DESCRIPTION OF APPLIED STANDARDS

The EUT is a Dual-Band Wireless-N Gigabit Router. According to the specifications of the manufacturer, it must comply with the requirements of the following standards:

FCC Part 15, Subpart E (15.407)

ANSI C63.4-2003

All test items have been performed and recorded as per the above standards.

NOTE: The EUT is also considered as a kind of computer peripheral, because the connection to computer is necessary for typical use. It has been verified to comply with the requirements of FCC Part 15, Subpart B, Class B (DoC). The test report has been issued separately.

3.4 DESCRIPTION OF SUPPORT UNITS

The EUT has been tested as an independent unit together with other necessary accessories or support units. The following support units or accessories were used to form a representative test configuration during the tests.

For Conducted test(Adapter 2):

NO.	PRODUCT	BRAND	MODEL NO.	SERIAL NO.	FCC ID
1	NOTEBOOK COMPUTER	DELL	PP18L	12252644560	FCC
2	NOTEBOOK COMPUTER	DELL	PPT	17044664176	E2K24GBRL
3	PERSONAL COMPUTER	DELL	DCSM	494QL1S	FCC DoC
4	MONITOR	DELL	2001FP	CN-0C0647-46633-5 33-043L	FCC DOC
5	KEYBOARD	DELL	SK-8115	MY-0J4635-71619-6 7V-0354	FCC Standards
6	MOUSE	DELL	M056UOA	FOROOSMZ	FCC DoC

NO.	SIGNAL CABLE DESCRIPTION OF THE ABOVE SUPPORT UNITS
1	NA
2	NA
3	NA
4	1.8m braid shielded wire , DVI & DSUB connector , with two cores.
5	1.8m foil shielded wire, USB Connector, w/o core.
6	1.8m foil shielded wire, USB Connector, w/o core.

For other test:

NO.	PRODUCT	BRAND	MODEL NO.	SERIAL NO.	FCC ID
1	NOTEBOOK COMPUTER	DELL	PP18L	6976685584	FCC DoC
2	NOTEBOOK COMPUTER	DELL	PP19L	CN-OHC416-70166- 5CA-0448	PIW632500516610
3	HUB	AVSYS	110H8	01-20E-000002	FCC DoC

NO.	SIGNAL CABLE DESCRIPTION OF THE ABOVE SUPPORT UNITS
1	NA
2	NA
3	NA

NOTE: All power cords of the above support units are non shielded (1.8m).

3.5 CONFIGURATION OF SYSTEM UNDER TEST

For Conducted test(Adapter 2):

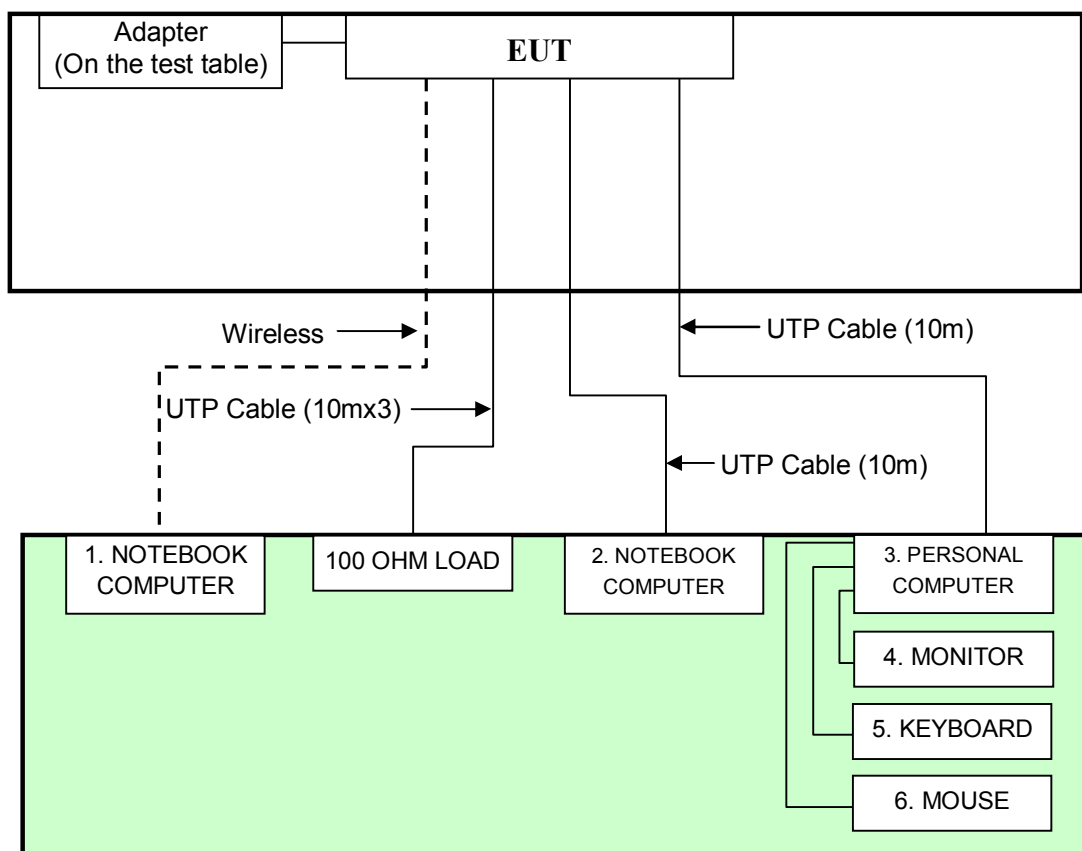

NOTE: 1. Support units 1 ~6 were kept in the control room during the test.

For other test:

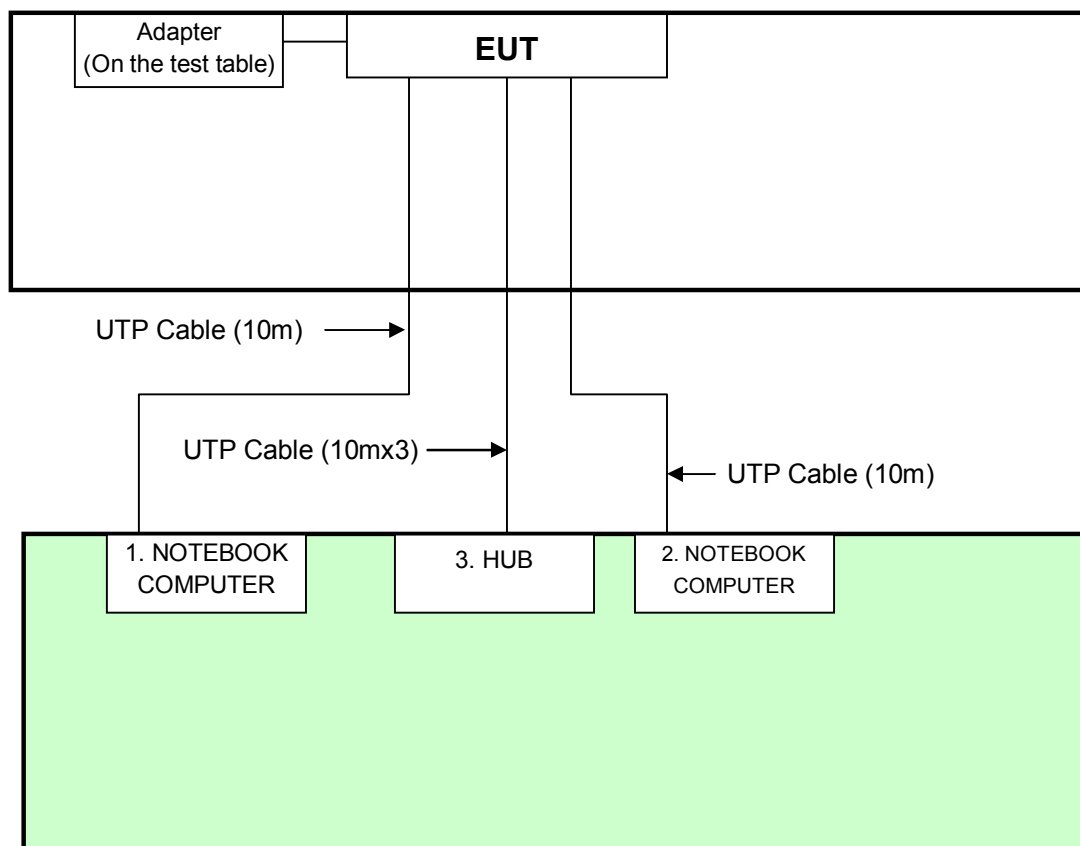

NOTE: 1. Support units 1 ~3 were kept in the control room during the test.

4. TEST TYPES AND RESULTS

4.1 CONDUCTED EMISSION MEASUREMENT

4.1.1 LIMITS OF CONDUCTED EMISSION MEASUREMENT

FREQUENCY OF EMISSION (MHz)	CONDUCTED LIMIT (dB μ V)	
	Quasi-peak	Average
0.15-0.5	66 to 56	56 to 46
0.5-5	56	46
5-30	60	50

- NOTE:**
1. The lower limit shall apply at the transition frequencies.
 2. The limit decreases in line with the logarithm of the frequency in the range of 0.15 to 0.50 MHz.
 3. All emanations from a class A/B digital device or system, including any network of conductors and apparatus connected thereto, shall not exceed the level of field strengths specified above.

4.1.2 TEST INSTRUMENTS

For adapter 1:

DESCRIPTION & MANUFACTURER	MODEL NO.	SERIAL NO.	CALIBRATED DATE	CALIBRATED UNTIL
ROHDE & SCHWARZ Test Receiver	ESCS 30	100287	March 11, 2008	March 10, 2009
Line-Impedance Stabilization Network(for EUT)	KNW-407	8-1395-12	May 07, 2008	May 06, 2009
Line-Impedance Stabilization Network(for Peripheral)	ENV-216	100072	June 13, 2008	June 12, 2009
RF Cable (JYEBAO)	5DFB	COACAB-0 01	July 24, 2008	July 23, 2009
50 ohms Terminator	50	3	Nov. 16, 2008	Nov. 15, 2009
Software	BV ADT_Cond_V7. 3.6	NA	NA	NA

- NOTE:**
1. The calibration interval of the above test instruments is 12 months and the calibrations are traceable to NML/ROC and NIST/USA.
 2. The test was performed in Shielded Room No. A.
 3. The VCCI Con A Registration No. is C-817.



A D T

For adapter 2:

DESCRIPTION & MANUFACTURER	MODEL NO.	SERIAL NO.	CALIBRATED DATE	CALIBRATED UNTIL
ROHDE & SCHWARZ Test Receiver	ESCS 30	100287	Mar. 05, 2009	Mar. 04, 2010
Line-Impedance Stabilization Network (for EUT)	KNW-407	8-1395-12	May 07, 2008	May 06, 2009
Line-Impedance Stabilization Network (for Peripheral)	ENV-216	100072	June 13, 2008	June 12, 2009
RF Cable (JYBAO)	5DFB	COACAB-001	Dec 15, 2008	Dec 14, 2009
50 ohms Terminator	50	3	Nov. 05, 2008	Nov. 04, 2009
Software	BV ADT_Cond_V7.3.7	NA	NA	NA

- NOTE: 1. The calibration interval of the above test instruments is 12 months and the calibrations are traceable to NML/ROC and NIST/USA.
2. The test was performed in Shielded Room No. A.
3. The VCCI Con A Registration No. is C-817.

4.1.3 TEST PROCEDURES

- a. The EUT was placed 0.4 meters from the conducting wall of the shielded room with EUT being connected to the power mains through a line impedance stabilization network (LISN). Other support units were connected to the power mains through another LISN. The two LISNs
- b. provide 50 ohm/ 50uH of coupling impedance for the measuring instrument.
- c. Both lines of the power mains connected to the EUT were checked for maximum conducted interference.
- d. The frequency range from 150kHz to 30MHz was searched. Emission level under (Limit – 20dB) was not recorded.

4.1.4 DEVIATION FROM TEST STANDARD

No deviation

4.1.5 TEST SETUP

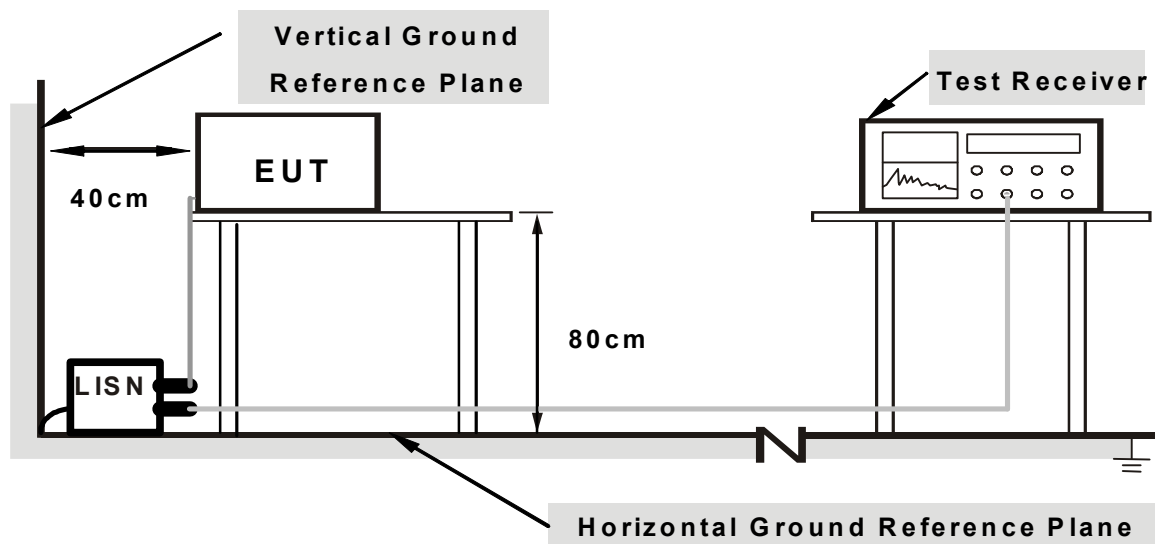

Note: 1. Support units were connected to second LISN.

2. Both of LISNs (AMN) are 80 cm from EUT and at least 80 from other units and other metal planes

For the actual test configuration, please refer to the related item – Photographs of the Test Configuration.

4.1.6 EUT OPERATING CONDITIONS

For adapter 1:

1. Placed the EUT on testing table.
2. Prepared other computer systems (support units 1 ~ 3) to act as communication partners and placed them outside of testing area.
3. The communication partners run test program "Ping.exe" to enable EUT under transmission/receiving condition continuously via UTP cables and wireless.

For adapter 2:

1. Placed the EUT on testing table.
2. Prepared other computer systems (support units 1 ~ 6) to act as communication partners and placed them outside of testing area.
3. The communication partners run test program "Ping.exe and Tfgn.exe" to enable EUT under transmission/receiving condition continuously via UTP cables and wireless.

4.1.7 TEST RESULTS-Adapter 1

DRAFT 802.11n (40MHz) OFDM MODULATION:

EUT TEST CONDITION		MEASUREMENT DETAIL	
CHANNEL	Channel 2	PHASE	Line (L)
MODULATION TYPE	BPSK	6dB BANDWIDTH	9 kHz
TRANSFER RATE	13.5Mbps	INPUT POWER	120Vac, 60 Hz
ENVIRONMENTAL CONDITIONS	22deg. C, 57%RH, 965hPa	TESTED BY	Eagle Chen

No	Freq. [MHz]	Corr. Factor (dB)	Reading Value [dB (uV)]		Emission Level [dB (uV)]		Limit [dB (uV)]		Margin (dB)	
			Q.P.	AV.	Q.P.	AV.	Q.P.	AV.	Q.P.	AV.
1	0.166	0.58	47.21	-	47.79	-	65.18	55.18	-17.39	-
2	0.213	0.49	40.22	-	40.71	-	63.11	53.11	-22.39	-
3	0.252	0.47	37.14	-	37.61	-	61.71	51.71	-24.09	-
4	0.709	0.44	32.20	-	32.64	-	56.00	46.00	-23.36	-
5	7.110	0.56	33.60	-	34.16	-	60.00	50.00	-25.84	-
6	20.660	0.78	28.87	-	29.65	-	60.00	50.00	-30.35	-

- REMARKS:**
1. Q.P. and AV. are abbreviations of quasi-peak and average individually.
 2. "-": The Quasi-peak reading value also meets average limit and measurement with the average detector is unnecessary.
 3. The emission levels of other frequencies were very low against the limit.
 4. Margin value = Emission level - Limit value
 5. Correction factor = Insertion loss + Cable loss
 6. Emission Level = Correction Factor + Reading Value.

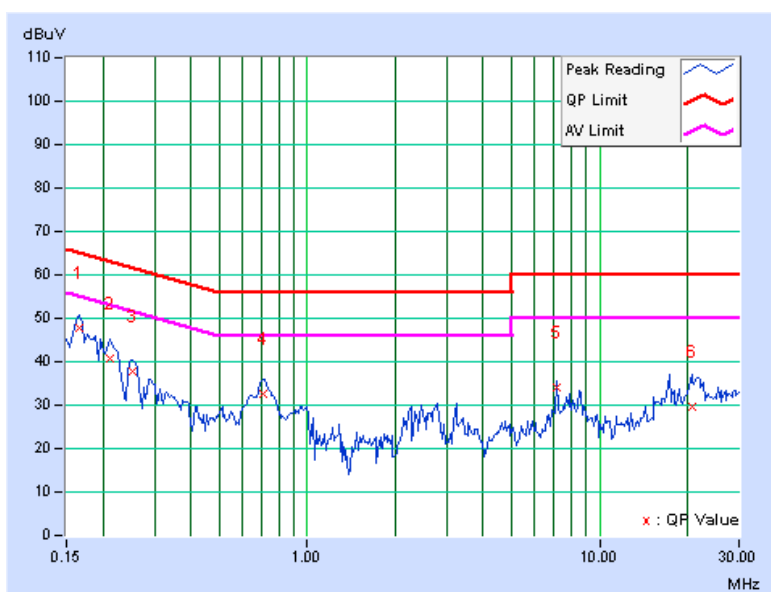



A D T

EUT TEST CONDITION		MEASUREMENT DETAIL	
CHANNEL	Channel 2	PHASE	Neutral (N)
MODULATION TYPE	BPSK	6dB BANDWIDTH	9 kHz
TRANSFER RATE	13.5Mbps	INPUT POWER	120Vac, 60 Hz
ENVIRONMENTAL CONDITIONS	22deg. C, 57%RH, 965hPa	TESTED BY	Eagle Chen

No	Freq. [MHz]	Corr. Factor [dB]	Reading Value [dB (uV)]		Emission Level [dB (uV)]		Limit [dB (uV)]		Margin (dB)	
			Q.P.	AV.	Q.P.	AV.	Q.P.	AV.	Q.P.	AV.
1	0.162	0.33	45.11	-	45.44	-	65.38	55.38	-19.93	-
2	0.209	0.25	40.32	-	40.57	-	63.26	53.26	-22.69	-
3	0.709	0.20	32.48	-	32.68	-	56.00	46.00	-23.32	-
4	7.109	0.35	40.11	-	40.46	-	60.00	50.00	-19.54	-
5	8.527	0.39	35.80	-	36.19	-	60.00	50.00	-23.81	-
6	22.184	0.66	29.62	-	30.28	-	60.00	50.00	-29.72	-

- REMARKS:**
1. Q.P. and AV. are abbreviations of quasi-peak and average individually.
 2. "-": The Quasi-peak reading value also meets average limit and measurement with the average detector is unnecessary.
 3. The emission levels of other frequencies were very low against the limit.
 4. Margin value = Emission level - Limit value
 5. Correction factor = Insertion loss + Cable loss
 6. Emission Level = Correction Factor + Reading Value.

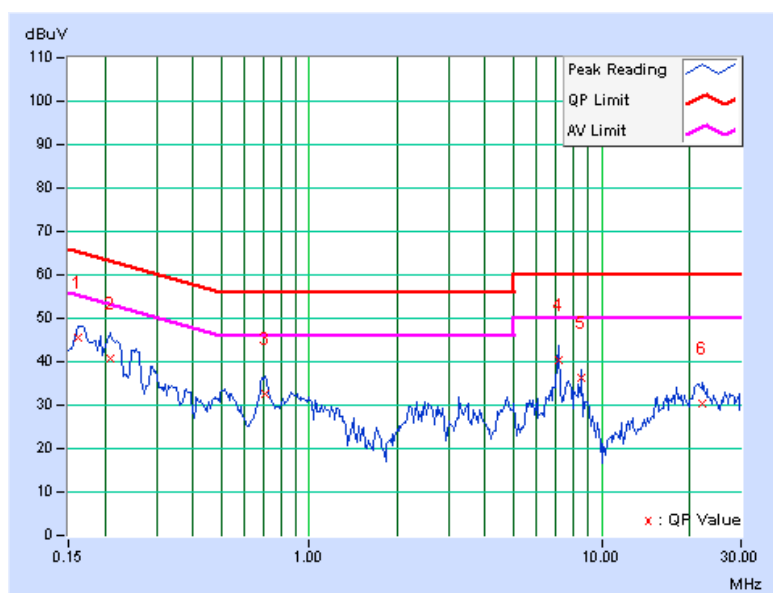

4.1.8 TEST RESULTS-Adapter 2

DRAFT 802.11n (40MHz) OFDM MODULATION

EUT TEST CONDITION		MEASUREMENT DETAIL	
CHANNEL	Channel 4	PHASE	Line (L)
MODULATION TYPE	BPSK	6dB BANDWIDTH	9 kHz
TRANSFER RATE	13.5Mbps	INPUT POWER	120Vac, 60 Hz
ENVIRONMENTAL CONDITIONS	25deg. C, 72%RH, 960hPa	TESTED BY	Leo Peng

No	Freq. [MHz]	Corr. Factor [dB]	Reading Value [dB (uV)]		Emission Level [dB (uV)]		Limit [dB (uV)]		Margin (dB)	
			Q.P.	AV.	Q.P.	AV.	Q.P.	AV.	Q.P.	AV.
1	0.150	0.61	55.19	-	55.80	-	66.00	56.00	-10.19	-
2	0.162	0.59	54.63	-	55.22	-	65.37	55.37	-10.15	-
3	0.232	0.49	43.28	-	43.77	-	62.37	52.37	-18.60	-
4	0.494	0.41	37.76	-	38.17	-	56.10	46.10	-17.94	-
5	0.861	0.39	36.72	-	37.11	-	56.00	46.00	-18.89	-
6	2.111	0.40	36.37	-	36.77	-	56.00	46.00	-19.23	-

- REMARKS:**
1. Q.P. and AV. are abbreviations of quasi-peak and average individually.
 2. "-": The Quasi-peak reading value also meets average limit and measurement with the average detector is unnecessary.
 3. The emission levels of other frequencies were very low against the limit.
 4. Margin value = Emission level - Limit value
 5. Correction factor = Insertion loss + Cable loss
 6. Emission Level = Correction Factor + Reading Value.

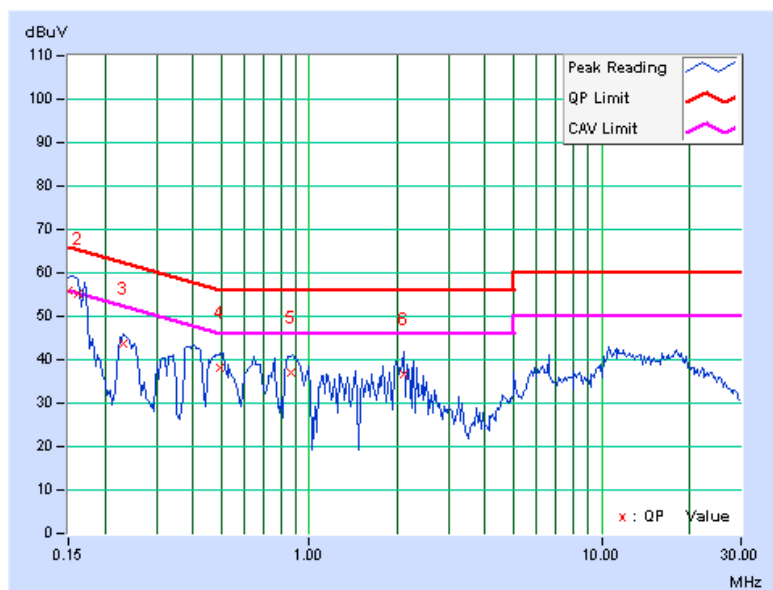



EUT TEST CONDITION		MEASUREMENT DETAIL	
CHANNEL	Channel 4	PHASE	Neutral (N)
MODULATION TYPE	BPSK	6dB BANDWIDTH	9 kHz
TRANSFER RATE	13.5Mbps	INPUT POWER	120Vac, 60 Hz
ENVIRONMENTAL CONDITIONS	25deg. C, 72%RH, 960hPa	TESTED BY	Leo Peng

No	Freq. [MHz]	Corr. Factor (dB)	Reading Value [dB (uV)]		Emission Level [dB (uV)]		Limit [dB (uV)]		Margin (dB)	
			Q.P.	AV.	Q.P.	AV.	Q.P.	AV.	Q.P.	AV.
1	0.150	0.36	54.72	-	55.08	-	65.99	55.99	-10.91	-
2	0.166	0.33	53.40	-	53.73	-	65.17	55.17	-11.44	-
3	0.384	0.19	41.22	-	41.41	-	58.18	48.18	-16.78	-
4	0.652	0.17	37.62	-	37.79	-	56.00	46.00	-18.21	-
5	0.873	0.16	37.48	-	37.64	-	56.00	46.00	-18.36	-
6	2.116	0.18	36.30	-	36.48	-	56.00	46.00	-19.52	-

- REMARKS:**
1. Q.P. and AV. are abbreviations of quasi-peak and average individually.
 2. "-": The Quasi-peak reading value also meets average limit and measurement with the average detector is unnecessary.
 3. The emission levels of other frequencies were very low against the limit.
 4. Margin value = Emission level - Limit value
 5. Correction factor = Insertion loss + Cable loss
 6. Emission Level = Correction Factor + Reading Value.

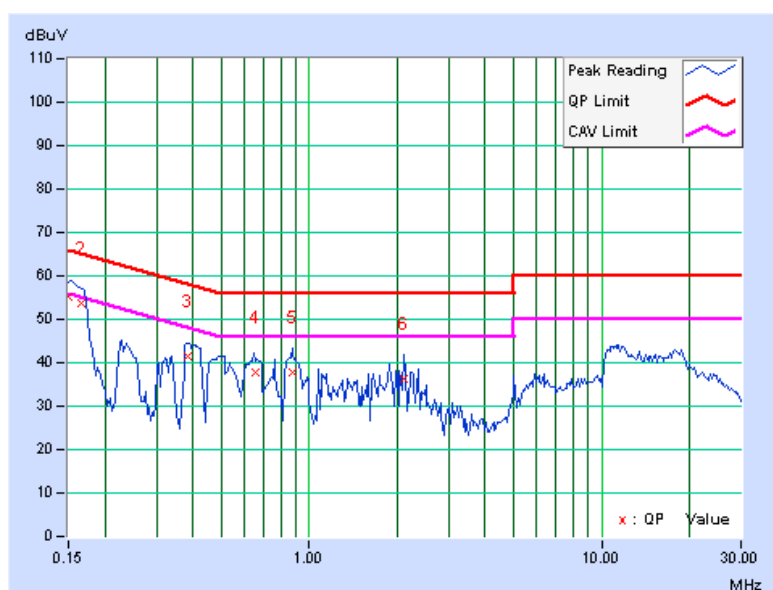

4.2 RADIATED EMISSION MEASUREMENT

4.2.1 LIMITS OF RADIATED EMISSION MEASUREMENT

Emissions radiated outside of the specified bands, shall be according to the general radiated limits in 15.209 as following:

Frequencies (MHz)	Field strength (microvolts/meter)	Measurement distance (meters)
0.009-0.490	2400/F(kHz)	300
0.490-1.705	24000/F(kHz)	30
1.705-30.0	30	30
30-88	100	3
88-216	150	3
216-960	200	3
Above 960	500	3

NOTE:

1. The lower limit shall apply at the transition frequencies.
2. Emission level (dBuV/m) = 20 log Emission level (uV/m).
3. As shown in 15.35(b), for frequencies above 1000MHz, the field strength limits are based on average detector, however, the peak field strength of any emission shall not exceed the maximum permitted average limits, specified above by more than 20dB under any condition of modulation.

4.2.2 LIMITS OF UNWANTED EMISSION OUT OF THE RESTRICTED BANDS

Frequencies (MHz)	EIRP Limit (dBm)	Equivalent Field Strength at 3m (dBμV/m) *note 3
5150~5250	-27	68.3
5250~5350	-27	68.3
5470~5725	-27	68.3
5725~5825	-27 *note 1	68.3
	-17 *note 2	78.3

NOTE:

1. For frequencies 10MHz or greater above or below the band edge.
2. All emissions within the frequency range from the band edge to 10MHz above or below the band edge.
3. The following formula is used to convert the equipment isotropic radiated power (eirp) to field strength

$$E = \frac{1000000\sqrt{30P}}{3} \mu\text{V/m, where P is the eirp (Watts)}$$



A D T

4.2.3 TEST INSTRUMENTS

For below 1GHz adapter 1 and above 1GHz test:

DESCRIPTION & MANUFACTURER	MODEL NO.	SERIAL NO.	CALIBRATED DATE	CALIBRATED UNTIL
ADVANTEST Spectrum Analyzer	R3271A	85060311	July 16, 2008	July 15, 2009
HP Pre_Amplifier	8449B	3008A0192 2	Sep. 25, 2008	Sep. 24, 2009
ROHDE & SCHWARZ Test Receiver	ESCS30	100375	April 01, 2008	Mar. 31, 2009
SCHWARZBECK TRILOG Broadband Antenna	VULB 9168	138	April 30, 2008	April 29, 2009
Schwarzbeck Horn_Antenna	BBHA9120	D124	Dec. 17, 2008	Dec. 16, 2009
Schwarzbeck Horn_Antenna	BBHA 9170	BBHA91701 53	Jan. 28, 2008	Jan. 27, 2009
RF Switches	EMH-011	08009	Oct. 07, 2008	Oct. 06, 2009
RF CABLE (Chaintek)	SF102	22054-2	Dec. 07, 2008	Dec. 06, 2009
RF Cable	8DFB	STCCAB-30 M-1GHz	Oct. 07, 2008	Oct. 06, 2009
Software	ADT_Radiated _V7.6.15.9.2	NA	NA	NA
CT Antenna Tower & Turn Table	NA	NA	NA	NA

- Note: 1. The calibration interval of the above test instruments is 12 months and the calibrations are traceable to NML/ROC and NIST/USA.
2. The horn antenna, HP preamplifier (model: 8449B) and Spectrum Analyzer (model: R3271A) are used only for the measurement of emission frequency above 1GHz if tested.
3. The test was performed in Open Site No. C.
4. The FCC Site Registration No. is 656396.
5. The VCCI Site Registration No. is R-1626.
6. The CANADA Site Registration No. is IC 7450G-3.



For below 1GHz adapter 2 test:

DESCRIPTION & MANUFACTURER	MODEL NO.	SERIAL NO.	CALIBRATED DATE	CALIBRATED UNTIL
ROHDE & SCHWARZ Spectrum Analyzer	FSP40	100036	Dec. 09, 2008	Dec. 08, 2009
HP Pre_Amplifier	8449B	3008A01923	Nov. 10, 2008	Nov. 09, 2009
ROHDE & SCHWARZ Test Receiver	ESCS30	847124/029	Sep. 09, 2008	Sep. 08, 2009
SCHWARZBECK TRILOG Broadband Antenna	VULB 9168	138	April 30, 2008	April 29, 2009
Schwarzbeck Horn_Antenna	BBHA9120	D124	Dec. 09, 2008	Dec. 08, 2009
Schwarzbeck Horn_Antenna	BBHA 9170	BBHA9170153	Jan. 22, 2009	Jan. 21, 2010
R&S Loop Antenna	HFH2-Z2	100070	Jan. 14, 2008	Jan. 13, 2010
RF Switches	EMH-011	08009	Oct. 07, 2008	Oct. 06, 2009
RF CABLE (Chaintek)	Sucoflex 106	28077	Aug. 15, 2008	Aug. 14, 2009
RF Cable	8DFB	STCCAB-30M-1GHz	Oct. 07, 2008	Oct. 06, 2009
Software	ADT_Radiated_V7.6.15.9.2	NA	NA	NA
CT Antenna Tower & Turn Table	NA	NA	NA	NA

- Note: 1. The calibration interval of the above test instruments is 12 months and the calibrations are traceable to NML/ROC and NIST/USA.
2. The horn antenna, HP preamplifier (model: 8449B) and Spectrum Analyzer (model: FSP40) are used only for the measurement of emission frequency above 1GHz if tested.
3. The test was performed in Open Site No. C.
4. The FCC Site Registration No. is 656396.
5. The VCCI Site Registration No. is R-1626.
6. The CANADA Site Registration No. is IC 7450G-3.

4.2.4 TEST PROCEDURES

- a. The EUT was placed on the top of a rotating table 0.8 meters above the ground at a 3 meter semi-anechoic chamber. The table was rotated 360 degrees to determine the position of the highest radiation.
- b. The EUT was set 3 meters away from the interference-receiving antenna, which was mounted on the top of a variable-height antenna tower.
- c. The antenna is a broadband antenna, and its height is varied from one meter to four meters above the ground to determine the maximum value of the field strength. Both horizontal and vertical polarizations of the antenna are set to make the measurement.
- d. For each suspected emission, the EUT was arranged to its worst case and then the antenna was tuned to heights from 1 meter to 4 meters and the rotatable table was turned from 0 degrees to 360 degrees to find the maximum reading.
- e. The test-receiver system was set to Peak Detect Function and Specified Bandwidth with Maximum Hold Mode.
- f. If the emission level of the EUT in peak mode was 10dB lower than the limit specified, then testing could be stopped and the peak values of the EUT would be reported. Otherwise the emissions that did not have 10dB margin would be re-tested one by one using peak, quasi-peak or average method as specified and then reported in a data sheet.

NOTE:

1. The resolution bandwidth and video bandwidth of test receiver/spectrum analyzer is 120kHz for Peak detection (PK) and Quasi-peak detection (QP) at frequency below 1GHz.
2. The resolution bandwidth of test receiver/spectrum analyzer is 1 MHz and the video bandwidth is 3 MHz for Peak detection (PK) at frequency above 1GHz.
3. The resolution bandwidth of test receiver/spectrum analyzer is 1 MHz and the video bandwidth is 10 Hz for Average detection (AV) at frequency above 1GHz.

4.2.5 DEVIATION FROM TEST STANDARD

No deviation

4.2.6 TEST SETUP

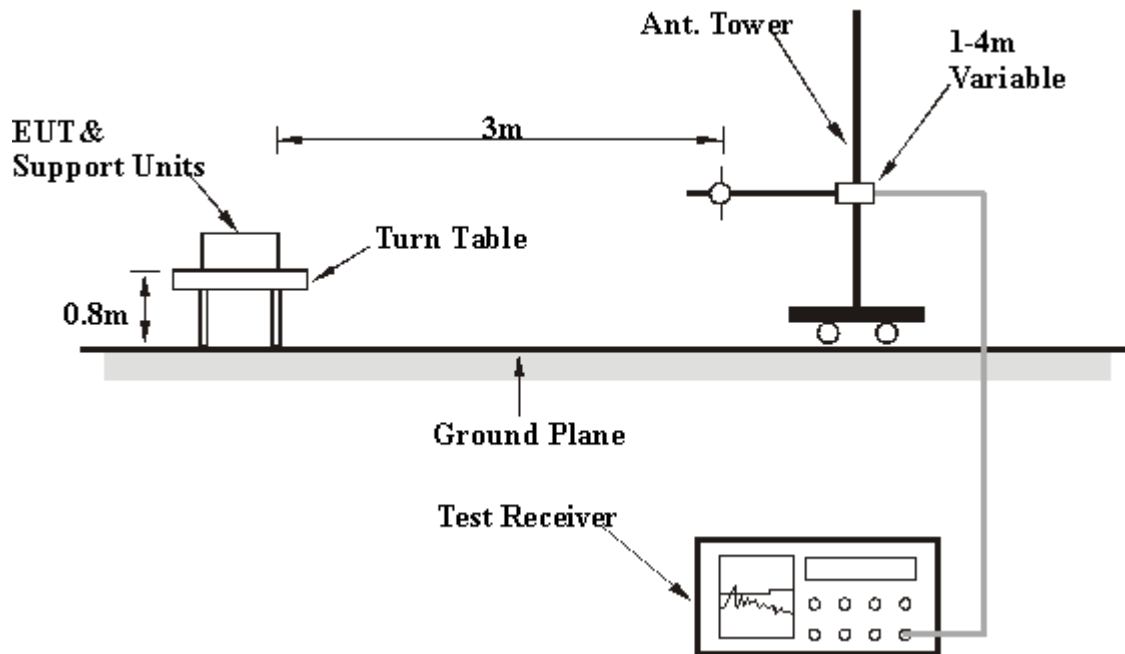

For the actual test configuration, please refer to the related item – Photographs of the Test Configuration.

4.2.7 EUT OPERATING CONDITION

1. Placed the EUT on testing table.
2. Prepared other computer systems (support units 1 ~ 3) to act as communication partners and placed them outside of testing area.
3. The communication partners run test program "Ping.exe" to enable EUT under transmission/receiving condition continuously via UTP cables and wireless.

Below 1GHz Test Data

4.2.8 TEST RESULTS-ADAPTER 1

BELOW 1GHz WORST-CASE DATA : DRAFT 802.11n (20MHz) OFDM MODULATION

EUT TEST CONDITION		MEASUREMENT DETAIL	
CHANNEL	Channel 1	FREQUENCY RANGE	Below 1000MHz
INPUT POWER	120Vac, 60 Hz	DETECTOR FUNCTION	Quasi-Peak
ENVIRONMENTAL CONDITIONS	25deg. C, 65%RH 965hPa	TESTED BY	Rex Huang

ANTENNA POLARITY & TEST DISTANCE: HORIZONTAL AT 3 M								
NO.	FREQ. (MHz)	EMISSION LEVEL (dBuV/m)	LIMIT (dBuV/m)	MARGIN (dB)	ANTENNA HEIGHT (m)	TABLE ANGLE (Degree)	RAW VALUE (dBuV)	CORRECTION FACTOR (dB/m)
1	39.49	18.13 QP	40.00	-21.87	1.40 H	278	4.93	13.20
2	125.00	30.78 QP	43.50	-12.72	1.29 H	264	16.66	14.12
3	250.00	36.78 QP	46.00	-9.22	1.02 H	259	21.36	15.42
4	375.00	38.13 QP	46.00	-7.87	1.29 H	321	18.03	20.10
5	500.00	36.65 QP	46.00	-9.35	1.43 H	78	13.99	22.66
6	625.00	35.64 QP	46.00	-10.36	1.15 H	49	10.30	25.34
7	750.00	34.65 QP	46.00	-11.35	1.00 H	164	6.19	28.46
8	875.00	38.45 QP	46.00	-7.55	1.00 H	123	7.73	30.72
ANTENNA POLARITY & TEST DISTANCE: VERTICAL AT 3 M								
NO.	FREQ. (MHz)	EMISSION LEVEL (dBuV/m)	LIMIT (dBuV/m)	MARGIN (dB)	ANTENNA HEIGHT (m)	TABLE ANGLE (Degree)	RAW VALUE (dBuV)	CORRECTION FACTOR (dB/m)
1	39.49	33.24 QP	40.00	-6.76	1.00 V	354	20.04	13.20
2	125.00	32.45 QP	43.50	-11.05	1.00 V	149	18.33	14.12
3	250.00	31.46 QP	46.00	-14.54	1.00 V	153	16.04	15.42
4	375.00	43.24 QP	46.00	-2.76	1.25 V	133	23.14	20.10
5	500.00	38.13 QP	46.00	-7.87	1.00 V	224	15.47	22.66
6	625.00	38.47 QP	46.00	-7.53	1.00 V	145	13.13	25.34
7	750.00	37.12 QP	46.00	-8.88	1.25 V	164	8.66	28.46
8	875.00	39.54 QP	46.00	-6.46	1.33 V	124	8.82	30.72

- REMARKS:**
1. Emission level (dBuV/m) = Raw Value (dBuV) + Correction Factor (dB/m).
 2. Correction Factor (dB/m) = Antenna Factor (dB/m) + Cable Factor (dB).
 3. The other emission levels were very low against the limit.
 4. Margin value = Emission level – Limit value.

4.2.9 TEST RESULTS-ADAPTER 2

BELOW 1GHz WORST-CASE DATA : DRAFT 802.11n (20MHz) OFDM MODULATION

EUT TEST CONDITION		MEASUREMENT DETAIL	
CHANNEL	Channel 1	FREQUENCY RANGE	Below 1000MHz
INPUT POWER	120Vac, 60 Hz	DETECTOR FUNCTION	Quasi-Peak
ENVIRONMENTAL CONDITIONS	25deg. C, 63%RH 960hPa	TESTED BY	Eric Lee

ANTENNA POLARITY & TEST DISTANCE: HORIZONTAL AT 3 M								
NO.	FREQ. (MHz)	EMISSION LEVEL (dBuV/m)	LIMIT (dBuV/m)	MARGIN (dB)	ANTENNA HEIGHT (m)	TABLE ANGLE (Degree)	RAW VALUE (dBuV)	CORRECTION FACTOR (dB/m)
1	125.010	25.60 QP	43.50	-17.90	1.51 H	252	11.48	14.12
2	219.980	34.90 QP	46.00	-11.10	1.60 H	250	20.94	13.96
3	249.990	43.11 QP	46.00	-2.89	1.13 H	109	27.69	15.42
4	333.290	37.70 QP	46.00	-8.30	1.00 H	120	19.32	18.38
5	375.010	38.99 QP	46.00	-7.01	1.16 H	107	18.89	20.10
6	749.980	35.11 QP	46.00	-10.89	1.63 H	91	6.65	28.46
7	875.010	41.01 QP	46.00	-4.99	1.57 H	33	10.29	30.72
ANTENNA POLARITY & TEST DISTANCE: VERTICAL AT 3 M								
NO.	FREQ. (MHz)	EMISSION LEVEL (dBuV/m)	LIMIT (dBuV/m)	MARGIN (dB)	ANTENNA HEIGHT (m)	TABLE ANGLE (Degree)	RAW VALUE (dBuV)	CORRECTION FACTOR (dB/m)
1	125.020	38.90 QP	43.50	-4.60	1.08 V	13	24.78	14.12
2	375.010	41.03 QP	46.00	-4.97	1.40 V	25	20.93	20.10
3	625.020	42.17 QP	46.00	-3.83	1.60 V	247	16.83	25.34
4	750.000	36.10 QP	46.00	-9.90	1.52 V	344	7.64	28.46
5	875.010	35.80 QP	46.00	-10.20	1.14 V	49	5.08	30.72
6	999.900	39.10 QP	54.00	-14.90	1.03 V	43	6.40	32.70

- REMARKS:**
1. Emission level (dBuV/m) = Raw Value (dBuV) + Correction Factor (dB/m).
 2. Correction Factor (dB/m) = Antenna Factor (dB/m) + Cable Factor (dB).
 3. The other emission levels were very low against the limit.
 4. Margin value = Emission level – Limit value.



A D T

Above 1GHz Test Data

4.2.10 TEST RESULTS

802.11a OFDM MODULATION

EUT TEST CONDITION		MEASUREMENT DETAIL	
CHANNEL	Channel 1	FREQUENCY RANGE	1 ~ 40GHz
INPUT POWER	120Vac, 60 Hz	DETECTOR FUNCTION	Peak (PK) Average (AV)
ENVIRONMENTAL CONDITIONS	25deg. C, 65%RH 965hPa	TESTED BY	Frank Liu

ANTENNA POLARITY & TEST DISTANCE: HORIZONTAL AT 3 M								
NO.	FREQ. (MHz)	EMISSION LEVEL (dBuV/m)	LIMIT (dBuV/m)	MARGIN (dB)	ANTENNA HEIGHT (m)	TABLE ANGLE (Degree)	RAW VALUE (dBuV)	CORRECTION FACTOR (dB/m)
1	4144.00	54.89 PK	74.00	-19.11	1.20 H	317	20.72	34.17
2	4144.00	41.14 AV	54.00	-12.86	1.20 H	317	6.97	34.17
3	5150.00	54.82 PK	74.00	-19.18	1.89 H	278	18.61	36.21
4	5150.00	42.07 AV	54.00	-11.93	1.89 H	278	5.86	36.21
5	*5180.00	107.98 PK			1.85 H	268	71.74	36.24
6	*5180.00	96.25 AV			1.85 H	268	60.01	36.24
7	#10360.00	64.01 PK	68.30	-4.29	1.14 H	84	18.03	45.98
ANTENNA POLARITY & TEST DISTANCE: VERTICAL AT 3 M								
NO.	FREQ. (MHz)	EMISSION LEVEL (dBuV/m)	LIMIT (dBuV/m)	MARGIN (dB)	ANTENNA HEIGHT (m)	TABLE ANGLE (Degree)	RAW VALUE (dBuV)	CORRECTION FACTOR (dB/m)
1	4144.00	55.13 PK	74.00	-18.87	1.62 V	48	20.96	34.17
2	4144.00	40.89 AV	54.00	-13.11	1.62 V	48	6.72	34.17
3	5150.00	65.83 PK	74.00	-8.17	1.60 V	321	29.62	36.21
4	5150.00	47.05 AV	54.00	-6.95	1.60 V	321	10.84	36.21
5	*5180.00	109.94 PK			1.60 V	322	73.70	36.24
6	*5180.00	98.39 AV			1.60 V	322	62.15	36.24
7	#10360.00	67.89 PK	68.30	-0.41	1.58 V	63	21.91	45.98

- REMARKS:**
1. Emission level (dBuV/m) = Raw Value (dBuV) + Correction Factor (dB/m).
 2. Correction Factor (dB/m) = Antenna Factor (dB/m) + Cable Factor (dB).
 3. The other emission levels were very low against the limit.
 4. Margin value = Emission level – Limit value.
 5. “ * “: Fundamental frequency.
 6. “#”:The radiated frequency is out the restricted band.



EUT TEST CONDITION		MEASUREMENT DETAIL	
CHANNEL	Channel 2	FREQUENCY RANGE	1 ~ 40GHz
INPUT POWER	120Vac, 60 Hz	DETECTOR FUNCTION	Peak (PK) Average (AV)
ENVIRONMENTAL CONDITIONS	25deg. C, 65%RH 965hPa	TESTED BY	Frank Liu

ANTENNA POLARITY & TEST DISTANCE: HORIZONTAL AT 3 M								
NO.	FREQ. (MHz)	EMISSION LEVEL (dBuV/m)	LIMIT (dBuV/m)	MARGIN (dB)	ANTENNA HEIGHT (m)	TABLE ANGLE (Degree)	RAW VALUE (dBuV)	CORRECTION FACTOR (dB/m)
1	4160.00	53.58 PK	74.00	-20.42	1.38 H	172	19.38	34.20
2	4160.00	40.65 AV	54.00	-13.35	1.38 H	172	6.45	34.20
3	*5200.00	106.48 PK			1.88 H	221	70.22	36.26
4	*5200.00	95.50 AV			1.88 H	221	59.24	36.26
5	#10400.00	63.89 PK	68.30	-4.41	1.42 H	88	17.80	46.09
ANTENNA POLARITY & TEST DISTANCE: VERTICAL AT 3 M								
NO.	FREQ. (MHz)	EMISSION LEVEL (dBuV/m)	LIMIT (dBuV/m)	MARGIN (dB)	ANTENNA HEIGHT (m)	TABLE ANGLE (Degree)	RAW VALUE (dBuV)	CORRECTION FACTOR (dB/m)
1	4160.00	55.28 PK	74.00	-18.72	1.73 V	62	21.08	34.20
2	4160.00	41.02 AV	54.00	-12.98	1.73 V	62	6.82	34.20
3	*5200.00	109.99 PK			1.52 V	310	73.73	36.26
4	*5200.00	98.94 AV			1.52 V	310	62.68	36.26
5	#10400.00	67.52 PK	68.30	-0.78	1.19 V	314	22.43	46.09

- REMARKS:**
1. Emission level (dBuV/m) = Raw Value (dBuV) + Correction Factor (dB/m).
 2. Correction Factor (dB/m) = Antenna Factor (dB/m) + Cable Factor (dB).
 3. The other emission levels were very low against the limit.
 4. Margin value = Emission level – Limit value.
 5. “ * “: Fundamental frequency.
 6. “#“: The radiated frequency is out the restricted band.



A D T

EUT TEST CONDITION		MEASUREMENT DETAIL	
CHANNEL	Channel 4	FREQUENCY RANGE	1 ~ 40GHz
INPUT POWER	120Vac, 60 Hz	DETECTOR FUNCTION	Peak (PK) Average (AV)
ENVIRONMENTAL CONDITIONS	25deg. C, 65%RH 965hPa	TESTED BY	Frank Liu

ANTENNA POLARITY & TEST DISTANCE: HORIZONTAL AT 3 M								
NO.	FREQ. (MHz)	EMISSION LEVEL (dBuV/m)	LIMIT (dBuV/m)	MARGIN (dB)	ANTENNA HEIGHT (m)	TABLE ANGLE (Degree)	RAW VALUE (dBuV)	CORRECTION FACTOR (dB/m)
1	4192.00	54.80 PK	74.00	-19.20	1.01 H	72	20.52	34.28
2	4192.00	41.64 AV	54.00	-12.36	1.01 H	72	7.36	34.28
3	*5240.00	107.25 PK			1.90 H	212	70.95	36.30
4	*5240.00	94.88 AV			1.90 H	212	58.58	36.30
5	5356.00	56.10 PK	74.00	-17.90	1.90 H	212	19.68	36.42
6	5356.00	43.20 AV	54.00	-10.80	1.90 H	212	6.78	36.42
7	#10480.00	64.59 PK	68.30	-3.71	1.82 H	271	18.29	46.30

ANTENNA POLARITY & TEST DISTANCE: VERTICAL AT 3 M								
NO.	FREQ. (MHz)	EMISSION LEVEL (dBuV/m)	LIMIT (dBuV/m)	MARGIN (dB)	ANTENNA HEIGHT (m)	TABLE ANGLE (Degree)	RAW VALUE (dBuV)	CORRECTION FACTOR (dB/m)
1	4192.00	55.60 PK	74.00	-18.40	1.42 V	163	21.32	34.28
2	4192.00	41.23 AV	54.00	-12.77	1.42 V	163	6.95	34.28
3	*5240.00	110.12 PK			1.42 V	300	73.82	36.30
4	*5240.00	99.58 AV			1.42 V	300	63.28	36.30
5	5360.00	56.94 PK	74.00	-17.06	1.14 V	181	20.52	36.42
6	5360.00	43.03 AV	54.00	-10.97	1.14 V	181	6.61	36.42
7	#10480.00	67.40 PK	68.30	-0.90	1.28 V	243	21.91	46.30

- REMARKS:**
1. Emission level (dBuV/m) = Raw Value (dBuV) + Correction Factor (dB/m).
 2. Correction Factor (dB/m) = Antenna Factor (dB/m) + Cable Factor (dB).
 3. The other emission levels were very low against the limit.
 4. Margin value = Emission level – Limit value.
 5. “ * “: Fundamental frequency.
 6. "#":The radiated frequency is out the restricted band.



A D T

RESTRICTED BANDEDGE (802.11a MODE, CH1, HORIZONTAL)

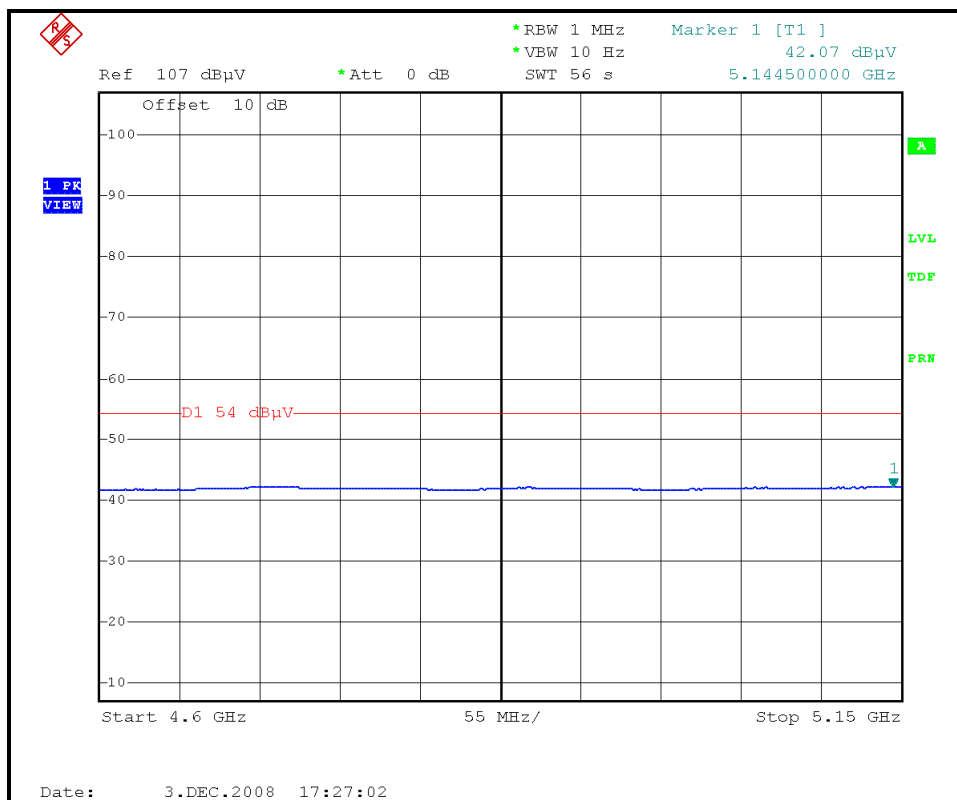
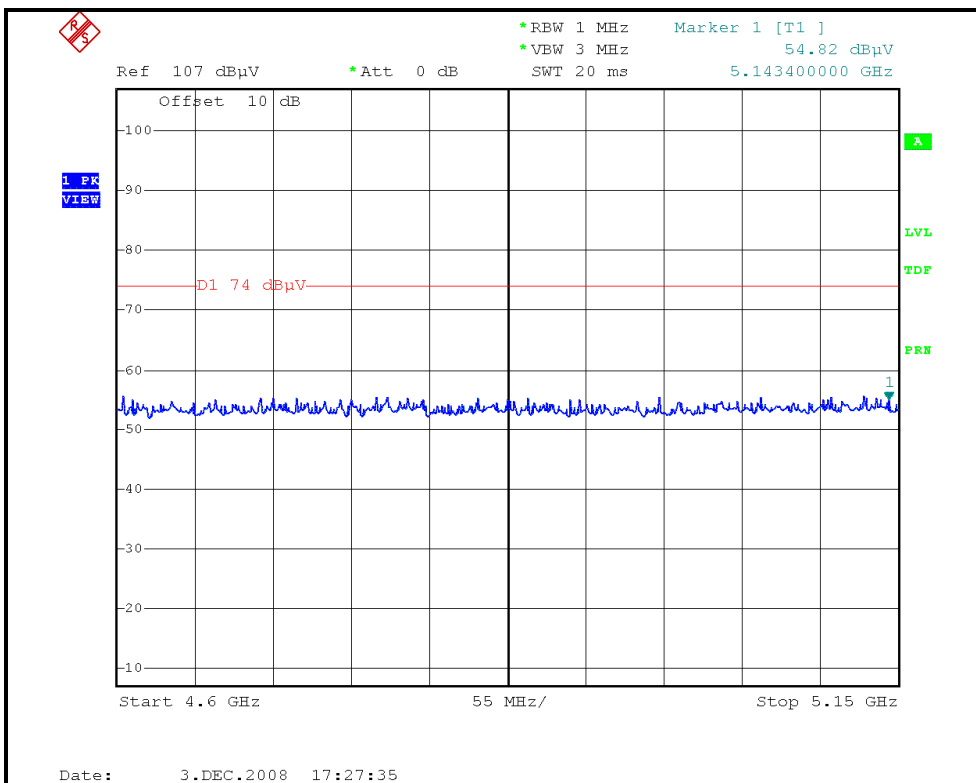



A D T

RESTRICTED BANDEDGE (802.11a MODE, CH1, VERTICAL)

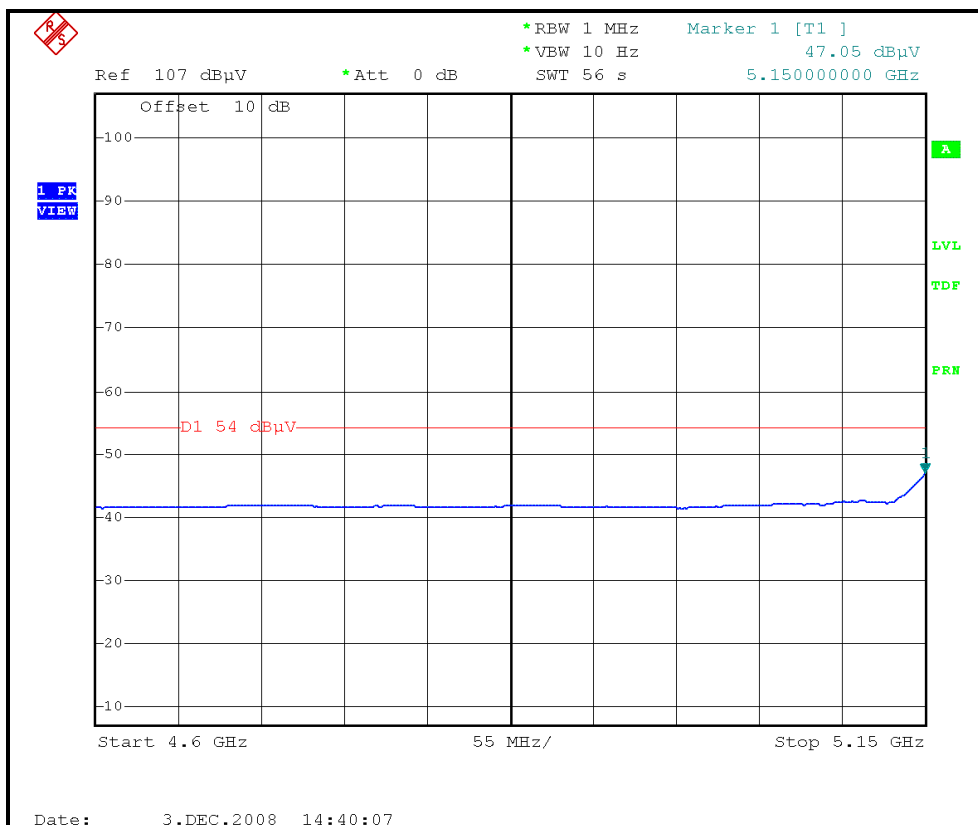
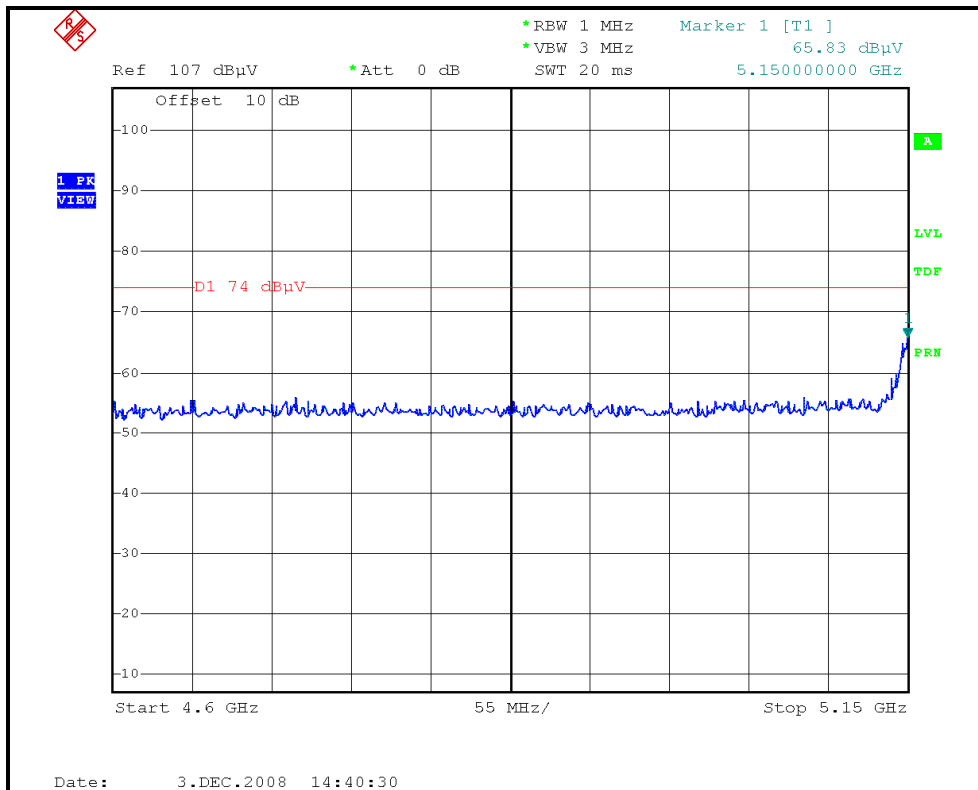



A D T

RESTRICTED BANDEDGE (802.11a MODE, CH4, HORIZONTAL)

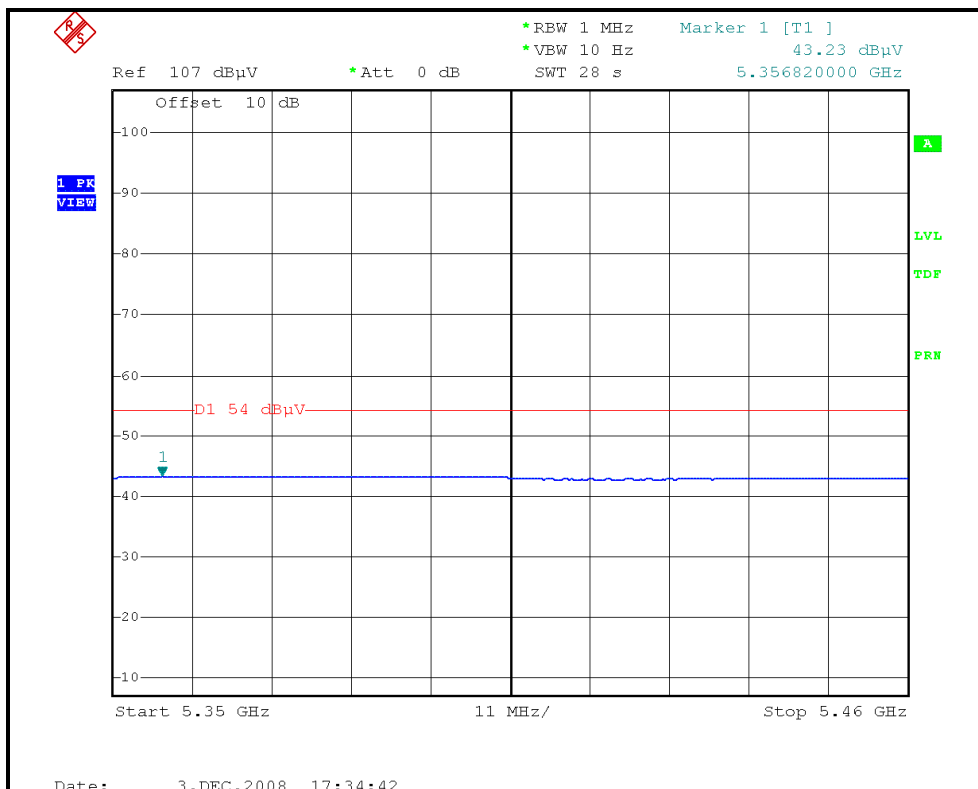
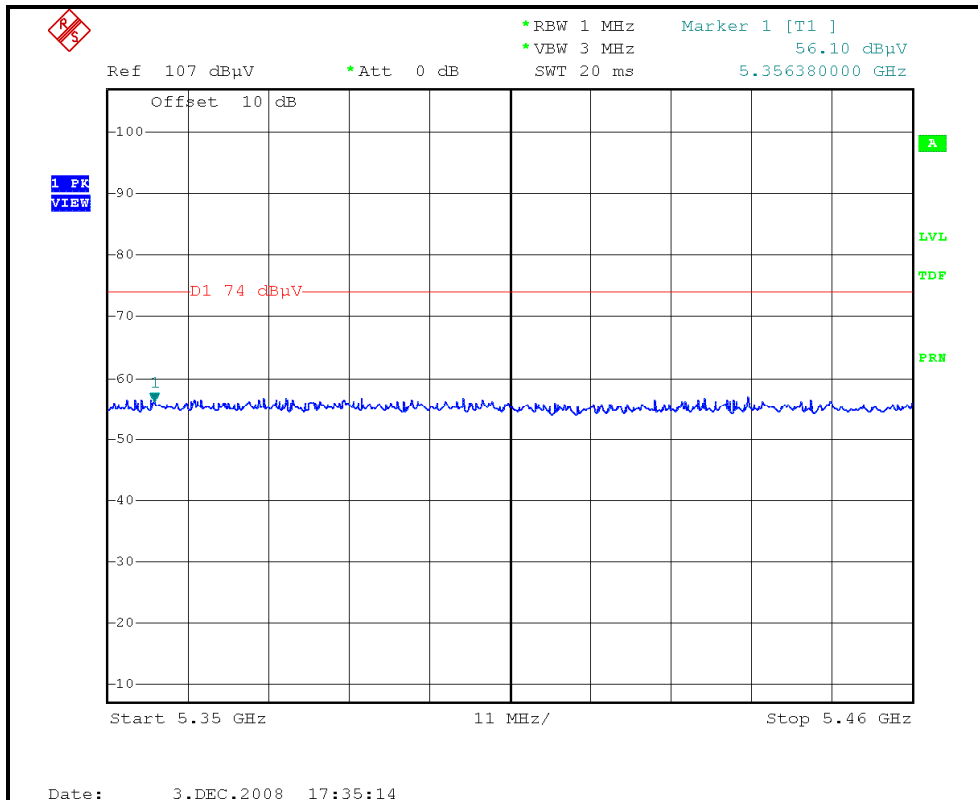



A D T

RESTRICTED BANDEDGE (802.11a MODE, CH4, VERTICAL)

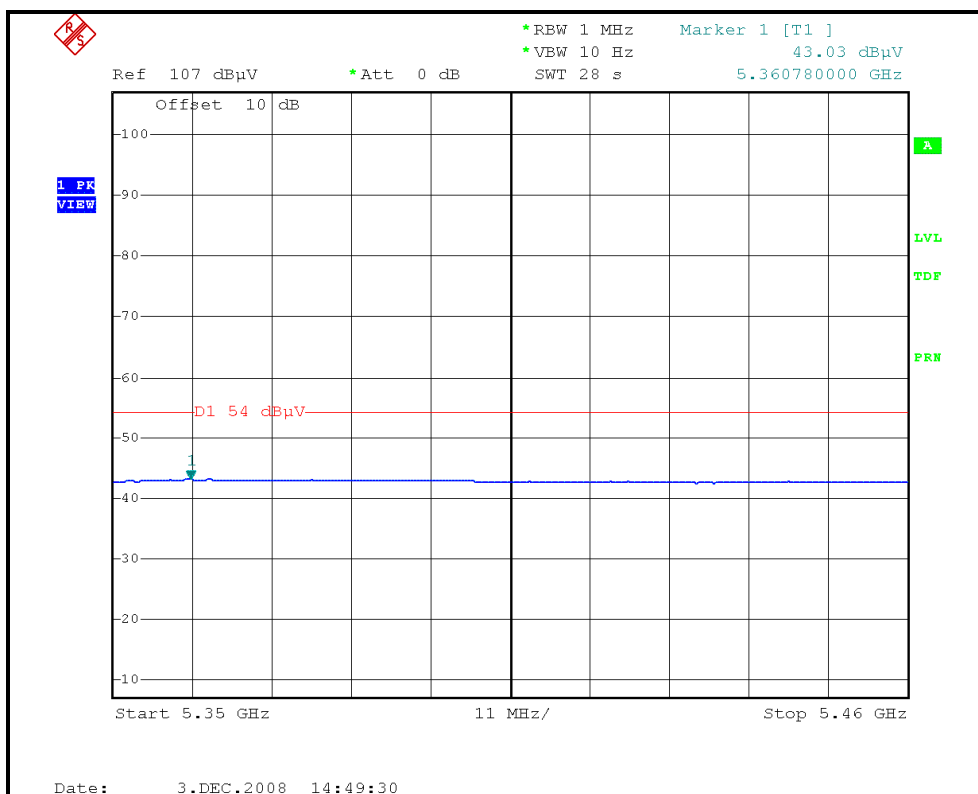
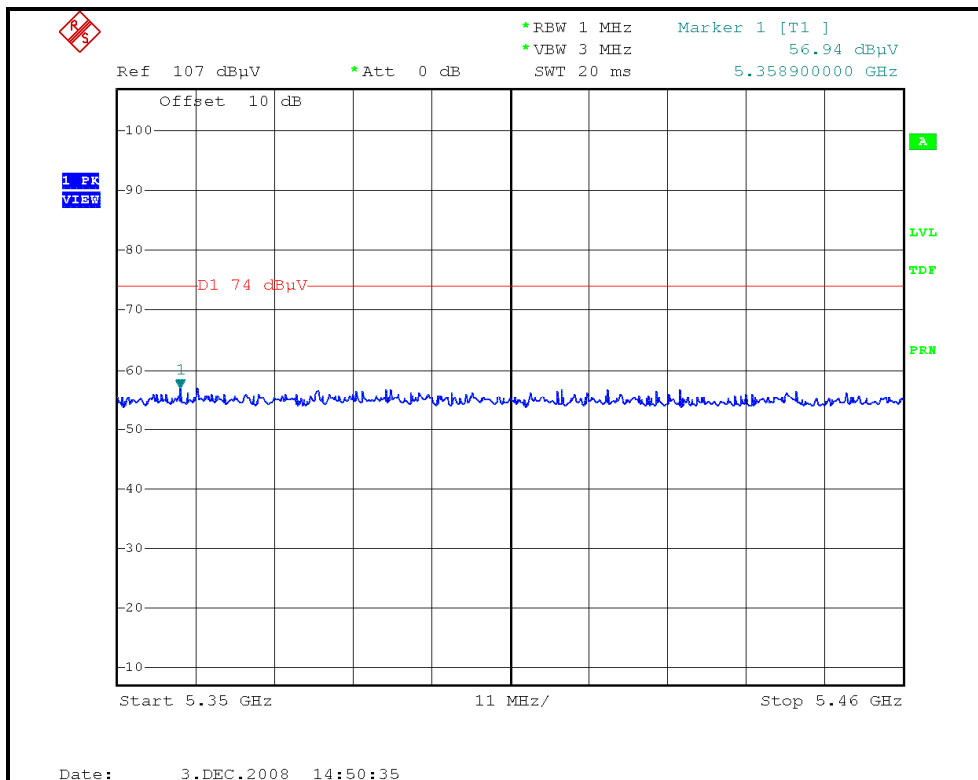



A D T

DRAFT 802.11n (20MHz) OFDM MODULATION

EUT TEST CONDITION		MEASUREMENT DETAIL	
CHANNEL	Channel 1	FREQUENCY RANGE	1 ~ 40GHz
INPUT POWER	120Vac, 60 Hz	DETECTOR FUNCTION	Peak (PK) Average (AV)
ENVIRONMENTAL CONDITIONS	25deg. C, 65%RH 965hPa	TESTED BY	Frank Liu

ANTENNA POLARITY & TEST DISTANCE: HORIZONTAL AT 3 M								
NO.	FREQ. (MHz)	EMISSION LEVEL (dBuV/m)	LIMIT (dBuV/m)	MARGIN (dB)	ANTENNA HEIGHT (m)	TABLE ANGLE (Degree)	RAW VALUE (dBuV)	CORRECTION FACTOR (dB/m)
1	4144.00	43.70 PK	74.00	-30.30	1.05 H	214	9.53	34.17
2	4144.00	30.60 AV	54.00	-23.40	1.05 H	214	-3.57	34.17
3	5150.00	68.49 PK	74.00	-5.51	2.04 H	98	32.28	36.21
4	5150.00	52.02 AV	54.00	-1.98	2.04 H	98	15.81	36.21
5	*5180.00	111.70 PK			2.04 H	99	75.46	36.24
6	*5180.00	99.90 AV			2.04 H	99	63.66	36.24
7	#10360.00	57.10 PK	68.30	-11.20	1.69 H	132	11.12	45.98

ANTENNA POLARITY & TEST DISTANCE: VERTICAL AT 3 M								
NO.	FREQ. (MHz)	EMISSION LEVEL (dBuV/m)	LIMIT (dBuV/m)	MARGIN (dB)	ANTENNA HEIGHT (m)	TABLE ANGLE (Degree)	RAW VALUE (dBuV)	CORRECTION FACTOR (dB/m)
1	4144.00	43.10 PK	74.00	-30.90	1.21 V	17	8.93	34.17
2	4144.00	30.20 AV	54.00	-23.80	1.21 V	17	-3.97	34.17
3	5150.00	66.82 PK	74.00	-7.18	1.38 V	159	30.61	36.21
4	5150.00	52.05 AV	54.00	-1.95	1.38 V	159	15.84	36.21
5	*5180.00	114.80 PK			1.37 V	192	78.56	36.24
6	*5180.00	103.40 AV			1.37 V	192	67.16	36.24
7	#10360.00	61.10 PK	68.30	-7.20	1.53 V	159	15.12	45.98

- REMARKS:**
1. Emission level (dBuV/m) = Raw Value (dBuV) + Correction Factor (dB/m).
 2. Correction Factor (dB/m) = Antenna Factor (dB/m) + Cable Factor (dB).
 3. The other emission levels were very low against the limit.
 4. Margin value = Emission level – Limit value.
 5. “ * “: Fundamental frequency.
 6. “#“:The radiated frequency is out the restricted band.



A D T

EUT TEST CONDITION		MEASUREMENT DETAIL	
CHANNEL	Channel 2	FREQUENCY RANGE	1 ~ 40GHz
INPUT POWER	120Vac, 60 Hz	DETECTOR FUNCTION	Peak (PK) Average (AV)
ENVIRONMENTAL CONDITIONS	25deg. C, %RH 965hPa	TESTED BY	Frank Liu

ANTENNA POLARITY & TEST DISTANCE: HORIZONTAL AT 3 M								
NO.	FREQ. (MHz)	EMISSION LEVEL (dBuV/m)	LIMIT (dBuV/m)	MARGIN (dB)	ANTENNA HEIGHT (m)	TABLE ANGLE (Degree)	RAW VALUE (dBuV)	CORRECTION FACTOR (dB/m)
1	4160.00	45.90 PK	74.00	-28.10	1.07 H	220	11.70	34.20
2	4160.00	33.40 AV	54.00	-20.60	1.07 H	220	-0.80	34.20
3	*5200.00	110.80 PK			2.01 H	100	74.54	36.26
4	*5200.00	99.70 AV			2.01 H	100	63.44	36.26
5	#10400.00	62.10 PK	68.30	-6.20	1.55 H	78	16.01	46.09
ANTENNA POLARITY & TEST DISTANCE: VERTICAL AT 3 M								
NO.	FREQ. (MHz)	EMISSION LEVEL (dBuV/m)	LIMIT (dBuV/m)	MARGIN (dB)	ANTENNA HEIGHT (m)	TABLE ANGLE (Degree)	RAW VALUE (dBuV)	CORRECTION FACTOR (dB/m)
1	4160.00	45.10 PK	74.00	-28.90	1.24 V	23	10.90	34.20
2	4160.00	32.30 AV	54.00	-21.70	1.24 V	23	-1.90	34.20
3	*5200.00	114.20 PK			1.36 V	195	77.94	36.26
4	*5200.00	103.00 AV			1.36 V	195	66.74	36.26
5	#10400.00	67.50 PK	68.30	-0.8	1.53 V	164	23.21	46.09

- REMARKS:**
1. Emission level (dBuV/m) = Raw Value (dBuV) + Correction Factor (dB/m).
 2. Correction Factor (dB/m) = Antenna Factor (dB/m) + Cable Factor (dB).
 3. The other emission levels were very low against the limit.
 4. Margin value = Emission level – Limit value.
 5. “ * “: Fundamental frequency.
 6. “#“: The radiated frequency is out the restricted band.



A D T

EUT TEST CONDITION		MEASUREMENT DETAIL	
CHANNEL	Channel 4	FREQUENCY RANGE	1 ~ 40GHz
INPUT POWER	120Vac, 60 Hz	DETECTOR FUNCTION	Peak (PK) Average (AV)
ENVIRONMENTAL CONDITIONS	25deg. C, 65%RH 965hPa	TESTED BY	Frank Liu

ANTENNA POLARITY & TEST DISTANCE: HORIZONTAL AT 3 M								
NO.	FREQ. (MHz)	EMISSION LEVEL (dBuV/m)	LIMIT (dBuV/m)	MARGIN (dB)	ANTENNA HEIGHT (m)	TABLE ANGLE (Degree)	RAW VALUE (dBuV)	CORRECTION FACTOR (dB/m)
1	4192.00	43.90 PK	74.00	-30.10	1.09 H	221	9.62	34.28
2	4192.00	31.40 AV	54.00	-22.60	1.09 H	221	-2.88	34.28
3	*5240.00	111.20 PK			2.02 H	133	74.90	36.30
4	*5240.00	99.80 AV			2.02 H	133	63.50	36.30
5	5396.80	59.61 PK	74.00	-14.39	2.03 H	102	23.15	36.46
6	5396.80	47.00 AV	54.00	-7.00	2.03 H	102	10.54	36.46
7	#10480.00	59.40 PK	68.30	-8.90	1.54 H	93	13.10	46.30

ANTENNA POLARITY & TEST DISTANCE: VERTICAL AT 3 M								
NO.	FREQ. (MHz)	EMISSION LEVEL (dBuV/m)	LIMIT (dBuV/m)	MARGIN (dB)	ANTENNA HEIGHT (m)	TABLE ANGLE (Degree)	RAW VALUE (dBuV)	CORRECTION FACTOR (dB/m)
1	4192.00	43.70 PK	74.00	-30.30	1.24 V	19	9.42	34.28
2	4192.00	30.60 AV	54.00	-23.40	1.24 V	19	-3.68	34.28
3	*5240.00	114.90 PK			1.35 V	194	78.60	36.30
4	*5240.00	103.20 AV			1.35 V	194	66.90	36.30
5	5396.80	58.90 PK	74.00	-15.10	1.35 V	194	22.44	36.46
6	5396.80	45.85 AV	54.00	-8.15	1.35 V	194	9.39	36.46
7	#10480.00	67.80 PK	68.30	-0.50	1.51 V	163	21.50	46.30

- REMARKS:**
1. Emission level (dBuV/m) = Raw Value (dBuV) + Correction Factor (dB/m).
 2. Correction Factor (dB/m) = Antenna Factor (dB/m) + Cable Factor (dB).
 3. The other emission levels were very low against the limit.
 4. Margin value = Emission level – Limit value.
 5. “ * “: Fundamental frequency.
 6. "#":The radiated frequency is out the restricted band.



A D T

RESTRICTED BANDEDGE (DRAFT 802.11n (20MHz) MODE,CH1, HORIZONTAL)

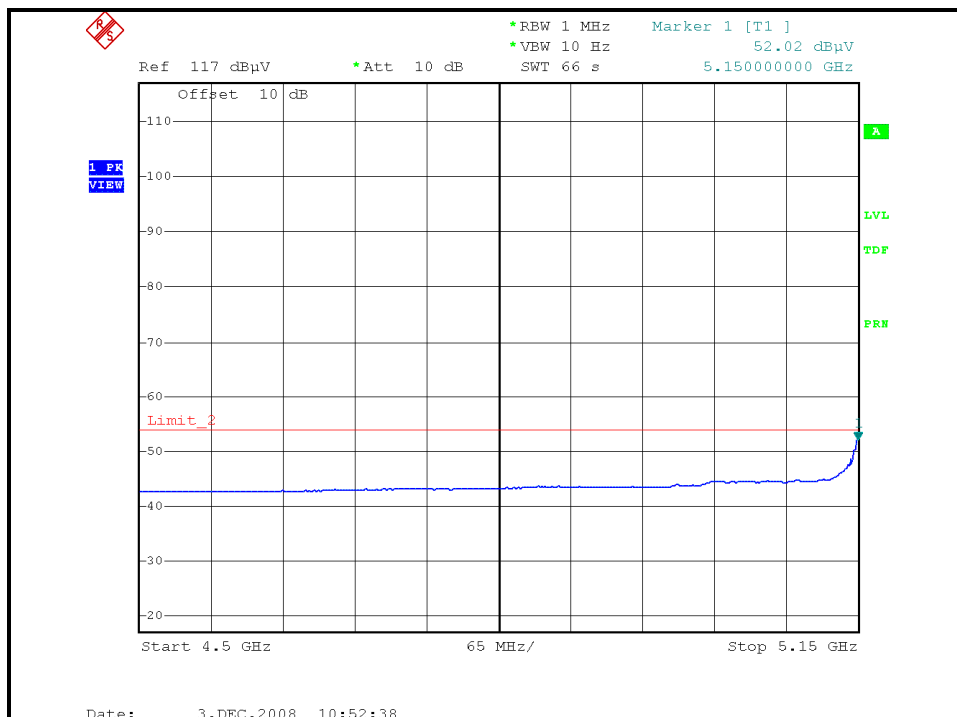
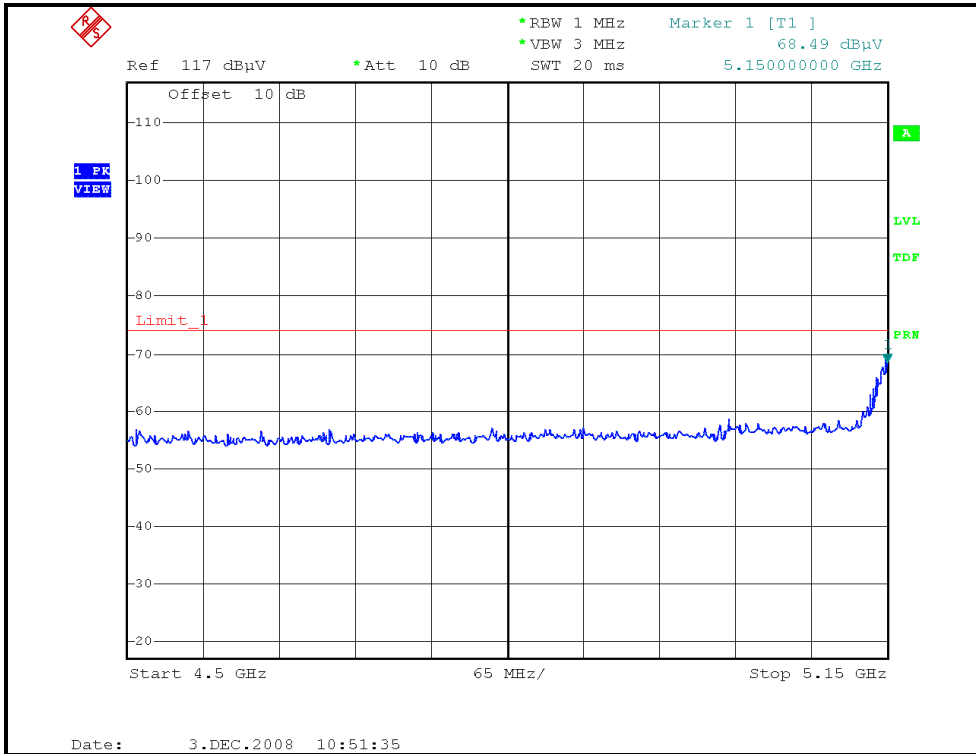



A D T

RESTRICTED BANDEDGE (DRAFT 802.11n (20MHz) MODE,CH1, VERTICAL)

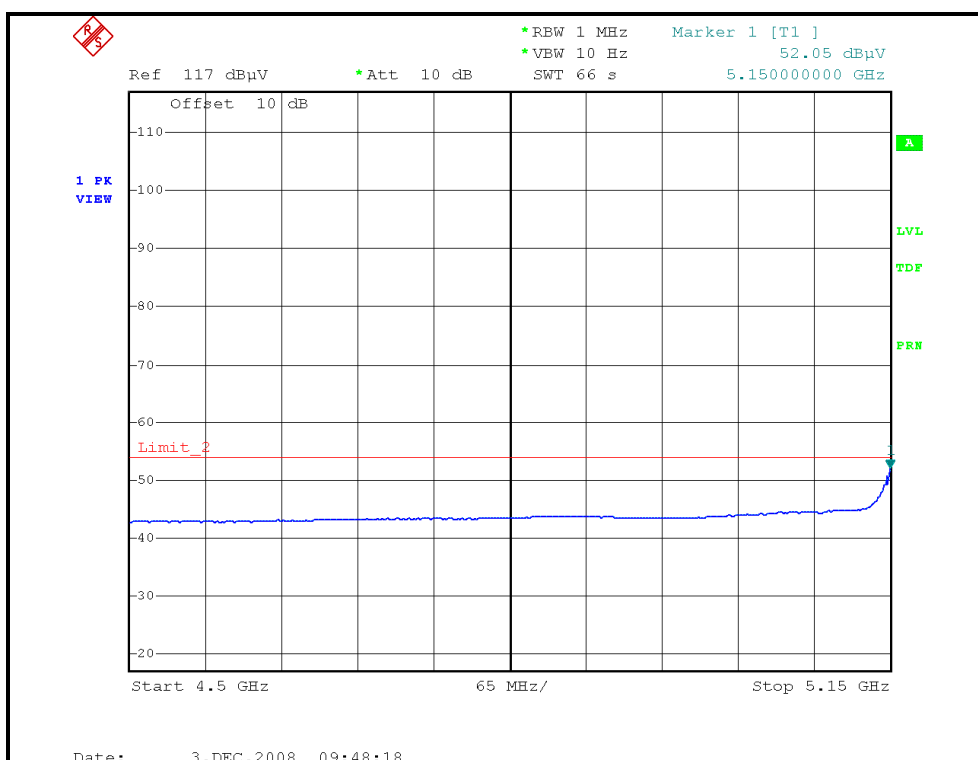
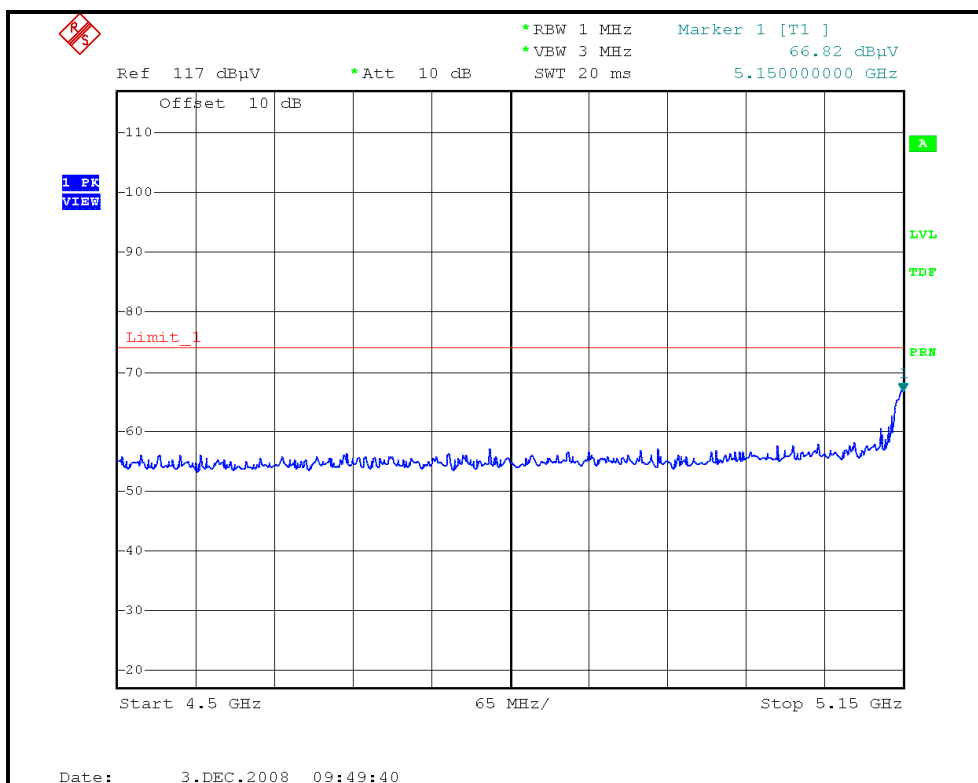



A D T

RESTRICTED BANDEDGE (DRAFT 802.11n (20MHz) MODE,CH4, HORIZONTAL)

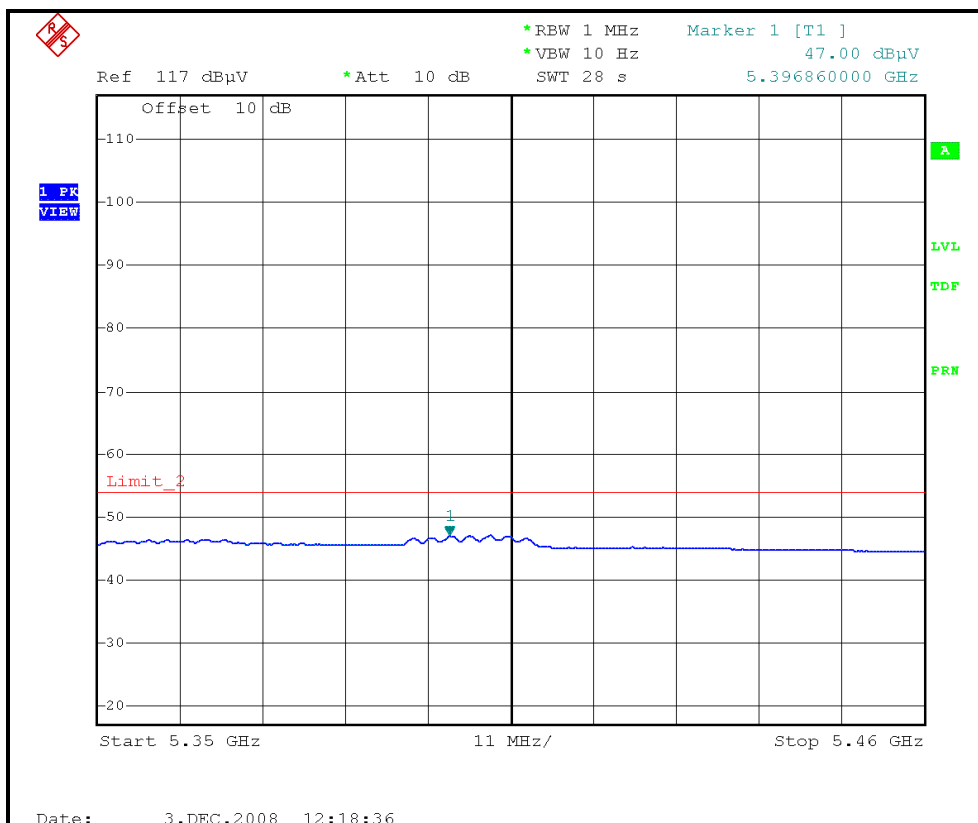
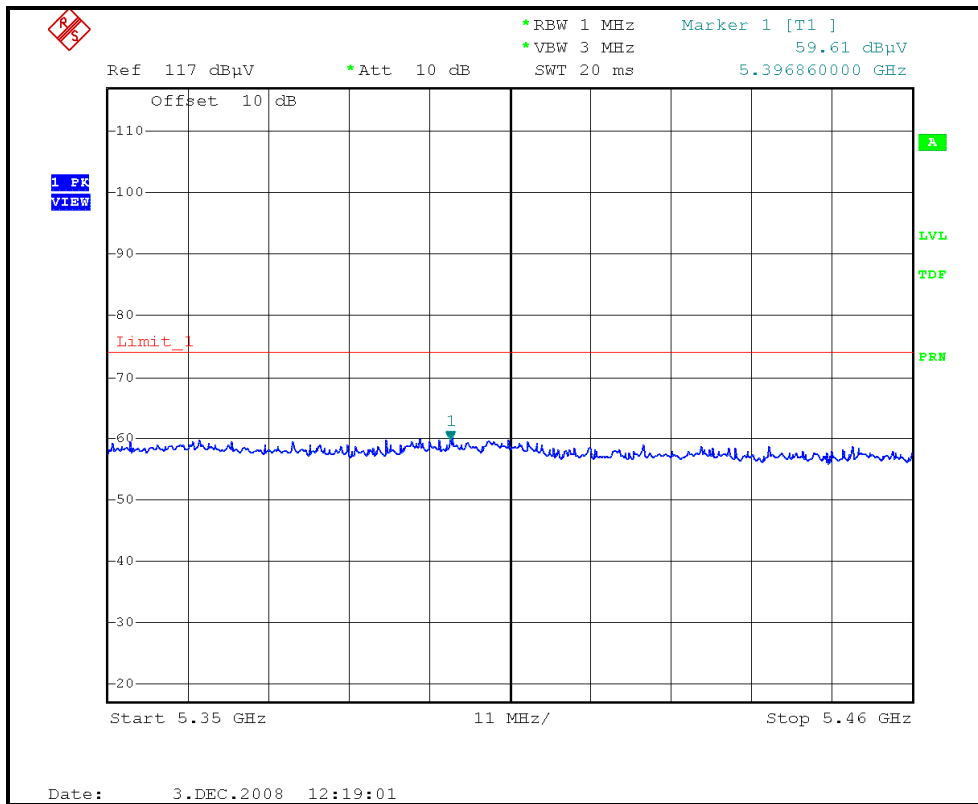



A D T

RESTRICTED BANDEDGE (DRAFT 802.11n (20MHz) MODE,CH4, VERTICAL)

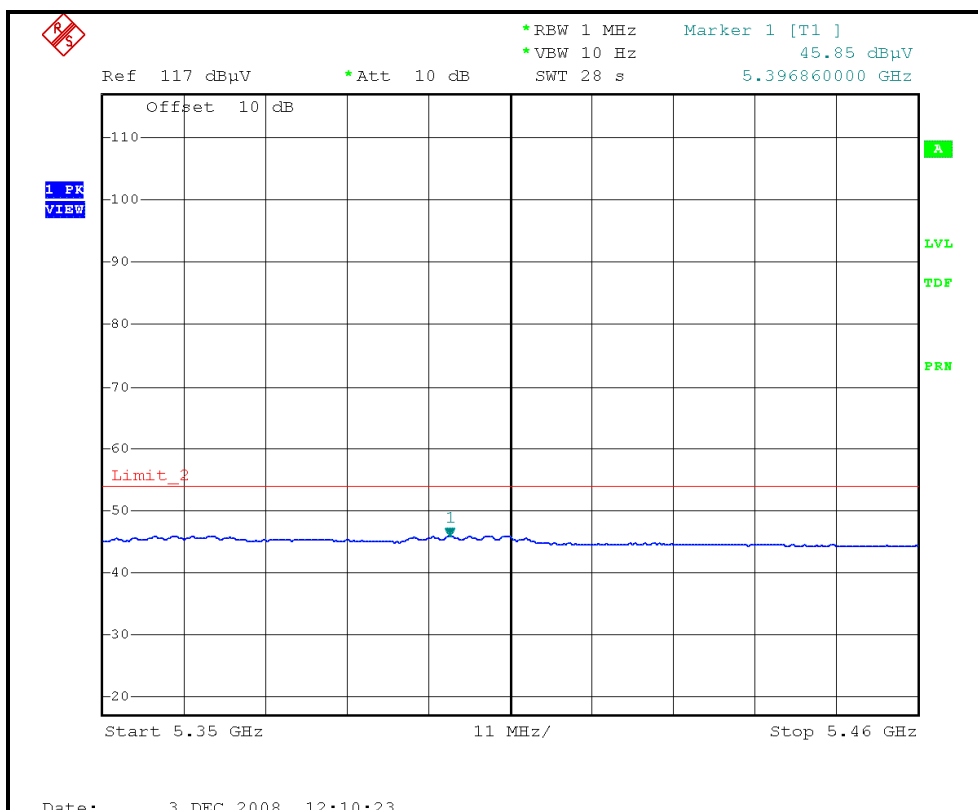
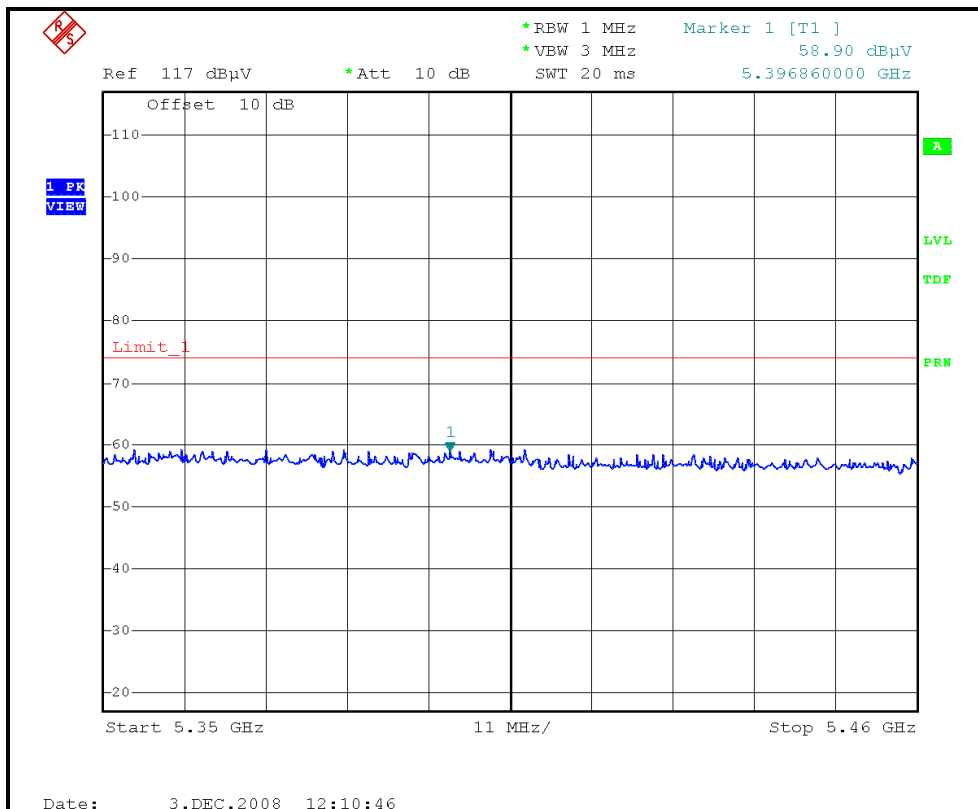

DRAFT 802.11n (40MHz) OFDM MODULATION

EUT TEST CONDITION		MEASUREMENT DETAIL	
CHANNEL	Channel 1	FREQUENCY RANGE	1 ~ 40GHz
INPUT POWER	120Vac, 60 Hz	DETECTOR FUNCTION	Peak (PK) Average (AV)
ENVIRONMENTAL CONDITIONS	25deg. C, 65%RH 965hPa	TESTED BY	Frank Liu

ANTENNA POLARITY & TEST DISTANCE: HORIZONTAL AT 3 M								
NO.	FREQ. (MHz)	EMISSION LEVEL (dBuV/m)	LIMIT (dBuV/m)	MARGIN (dB)	ANTENNA HEIGHT (m)	TABLE ANGLE (Degree)	RAW VALUE (dBuV)	CORRECTION FACTOR (dB/m)
1	4152.00	53.22 PK	74.00	-20.78	1.14 H	301	19.04	34.18
2	4152.00	41.11 AV	54.00	-12.89	1.14 H	301	6.93	34.18
3	5150.00	69.34 PK	74.00	-4.66	1.95 H	112	33.13	36.21
4	5150.00	51.80 AV	54.00	-2.20	1.95 H	112	15.59	36.21
5	*5190.00	108.91 PK			1.94 H	110	72.66	36.25
6	*5190.00	94.80 AV			1.94 H	110	58.55	36.25
7	#10380.00	64.88 PK	68.30	-3.42	1.24 H	280	18.84	46.04
ANTENNA POLARITY & TEST DISTANCE: VERTICAL AT 3 M								
NO.	FREQ. (MHz)	EMISSION LEVEL (dBuV/m)	LIMIT (dBuV/m)	MARGIN (dB)	ANTENNA HEIGHT (m)	TABLE ANGLE (Degree)	RAW VALUE (dBuV)	CORRECTION FACTOR (dB/m)
1	4152.00	54.83 PK	74.00	-19.17	1.09 V	162	20.65	34.18
2	4152.00	40.29 AV	54.00	-13.71	1.09 V	162	6.11	34.18
3	5150.00	69.01 PK	74.00	-4.99	1.06 V	165	32.80	36.21
4	5150.00	52.96 AV	54.00	-1.04	1.06 V	165	16.75	36.21
5	*5190.00	106.98 PK			1.06 V	212	70.73	36.25
6	*5190.00	92.91 AV			1.06 V	212	56.66	36.25
7	#10380.00	66.83 PK	68.30	-1.47	1.62 V	58	20.79	46.04

- REMARKS:**
1. Emission level (dBuV/m) = Raw Value (dBuV) + Correction Factor (dB/m).
 2. Correction Factor (dB/m) = Antenna Factor (dB/m) + Cable Factor (dB).
 3. The other emission levels were very low against the limit.
 4. Margin value = Emission level – Limit value.
 5. “ * “: Fundamental frequency.
 6. “#”:The radiated frequency is out the restricted band.



A D T

EUT TEST CONDITION		MEASUREMENT DETAIL	
CHANNEL	Channel 2	FREQUENCY RANGE	1 ~ 40GHz
INPUT POWER	120Vac, 60 Hz	DETECTOR FUNCTION	Peak (PK) Average (AV)
ENVIRONMENTAL CONDITIONS	25deg. C, 65%RH 965hPa	TESTED BY	Frank Liu

ANTENNA POLARITY & TEST DISTANCE: HORIZONTAL AT 3 M								
NO.	FREQ. (MHz)	EMISSION LEVEL (dBuV/m)	LIMIT (dBuV/m)	MARGIN (dB)	ANTENNA HEIGHT (m)	TABLE ANGLE (Degree)	RAW VALUE (dBuV)	CORRECTION FACTOR (dB/m)
1	4184.00	52.83 PK	74.00	-21.17	1.18 H	299	18.57	34.26
2	4184.00	42.63 AV	54.00	-11.37	1.18 H	299	8.37	34.26
3	*5230.00	109.71 PK			1.92 H	102	73.42	36.29
4	*5230.00	95.89 AV			1.92 H	102	59.60	36.29
5	5366.00	57.71 PK	74.00	-16.29	1.89 H	114	21.28	36.43
6	5366.00	43.67 AV	54.00	-10.33	1.89 H	114	7.24	36.43
7	#10460.00	65.65 PK	68.30	-2.65	1.30 H	304	19.40	46.25

ANTENNA POLARITY & TEST DISTANCE: VERTICAL AT 3 M								
NO.	FREQ. (MHz)	EMISSION LEVEL (dBuV/m)	LIMIT (dBuV/m)	MARGIN (dB)	ANTENNA HEIGHT (m)	TABLE ANGLE (Degree)	RAW VALUE (dBuV)	CORRECTION FACTOR (dB/m)
1	4184.00	53.65 PK	74.00	-20.35	1.72 V	100	19.39	34.26
2	4184.00	40.29 AV	54.00	-13.71	1.72 V	100	6.03	34.26
3	*5230.00	107.29 PK			1.10 V	208	71.00	36.29
4	*5230.00	93.28 AV			1.10 V	208	56.99	36.29
5	5368.00	57.14 PK	74.00	-16.86	1.10 V	101	20.71	36.43
6	5368.00	43.36 AV	54.00	-10.64	1.10 V	101	6.93	36.43
7	#10460.00	67.69 PK	68.30	-0.61	1.58 V	192	21.44	46.25

- REMARKS:**
1. Emission level (dBuV/m) = Raw Value (dBuV) + Correction Factor (dB/m).
 2. Correction Factor (dB/m) = Antenna Factor (dB/m) + Cable Factor (dB).
 3. The other emission levels were very low against the limit.
 4. Margin value = Emission level – Limit value.
 5. “ * “: Fundamental frequency.
 6. "#":The radiated frequency is out the restricted band.



A D T

RESTRICTED BANDEDGE (DRAFT 802.11n (40MHz) MODE, CH1, HORIZONTAL)

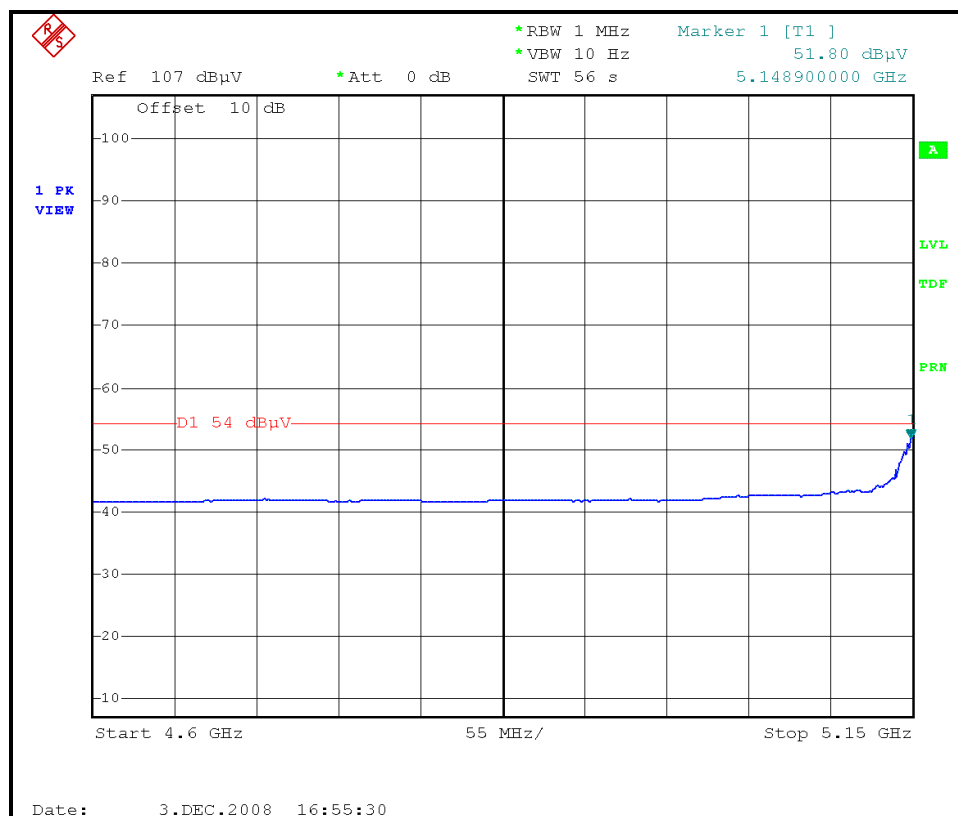
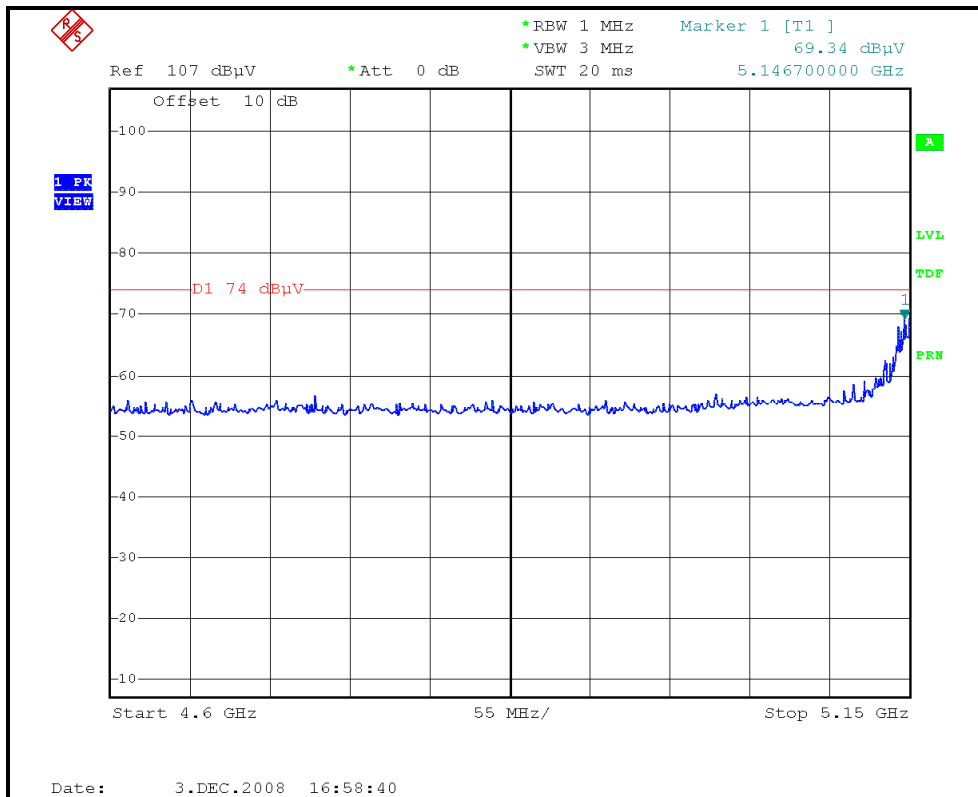



A D T

RESTRICTED BANDEDGE (DRAFT 802.11n (40MHz) MODE, CH1, VERTICAL)

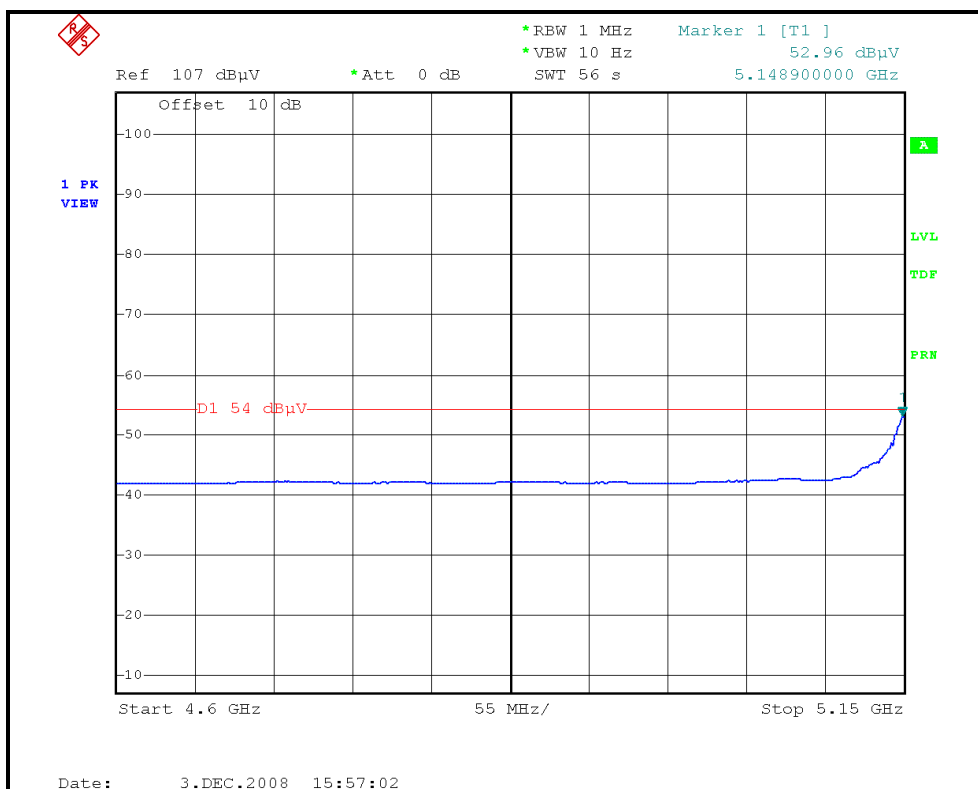
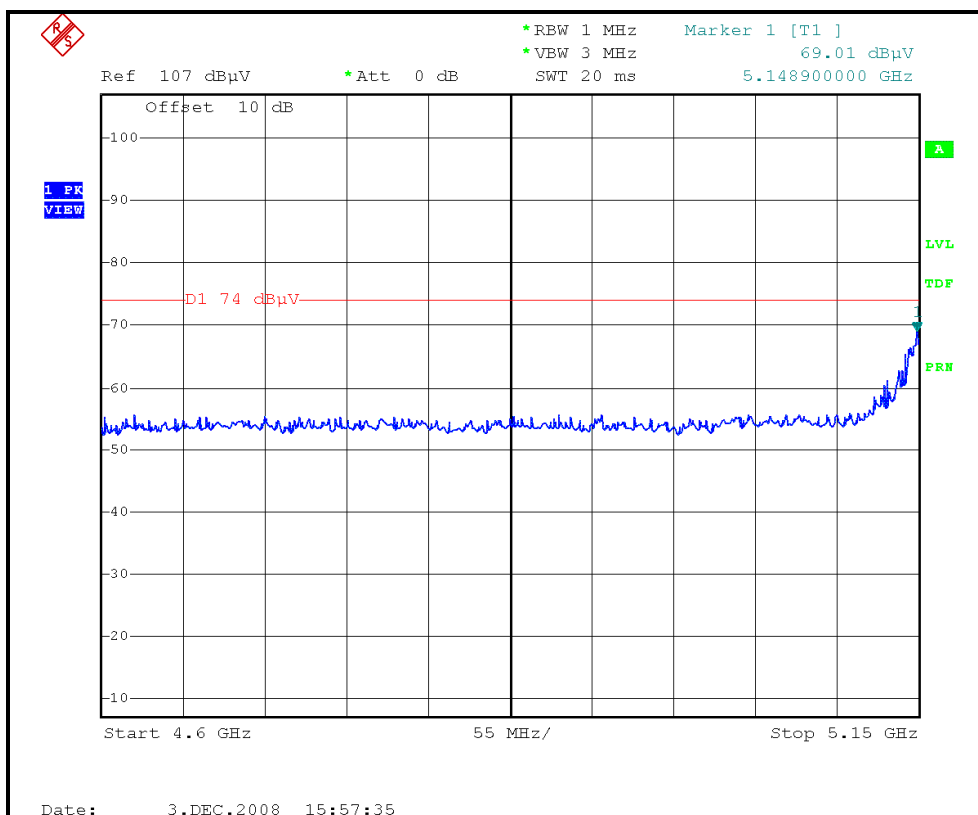



A D T

RESTRICTED BANDEDGE (DRAFT 802.11n (40MHz) MODE, CH2, HORIZONTAL)

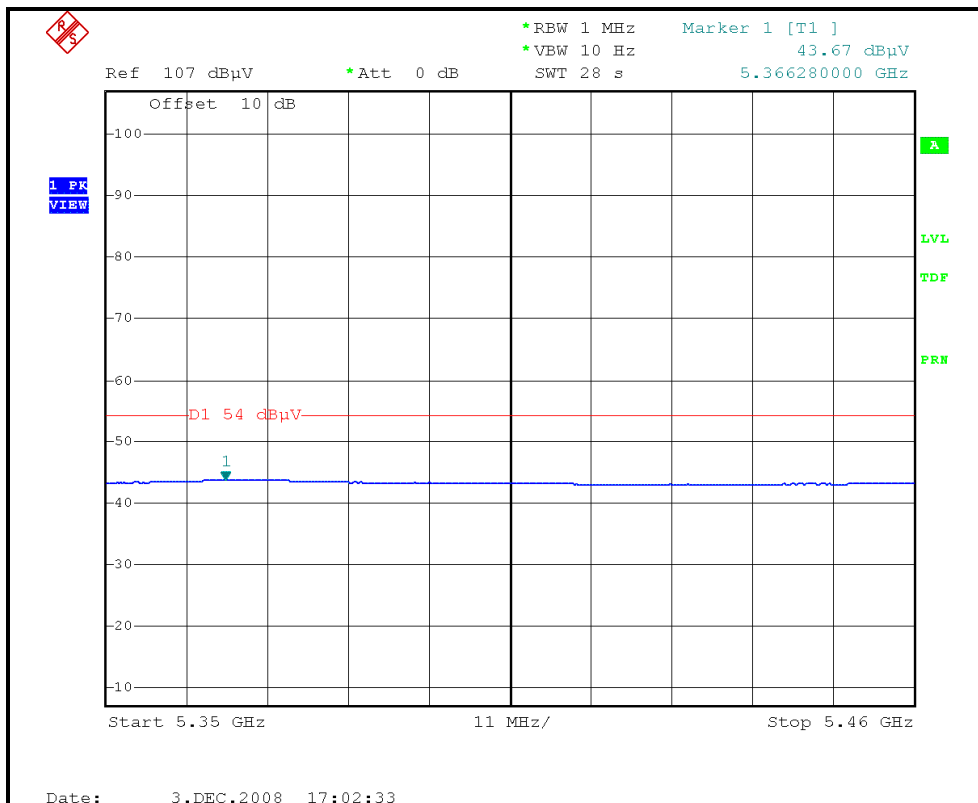
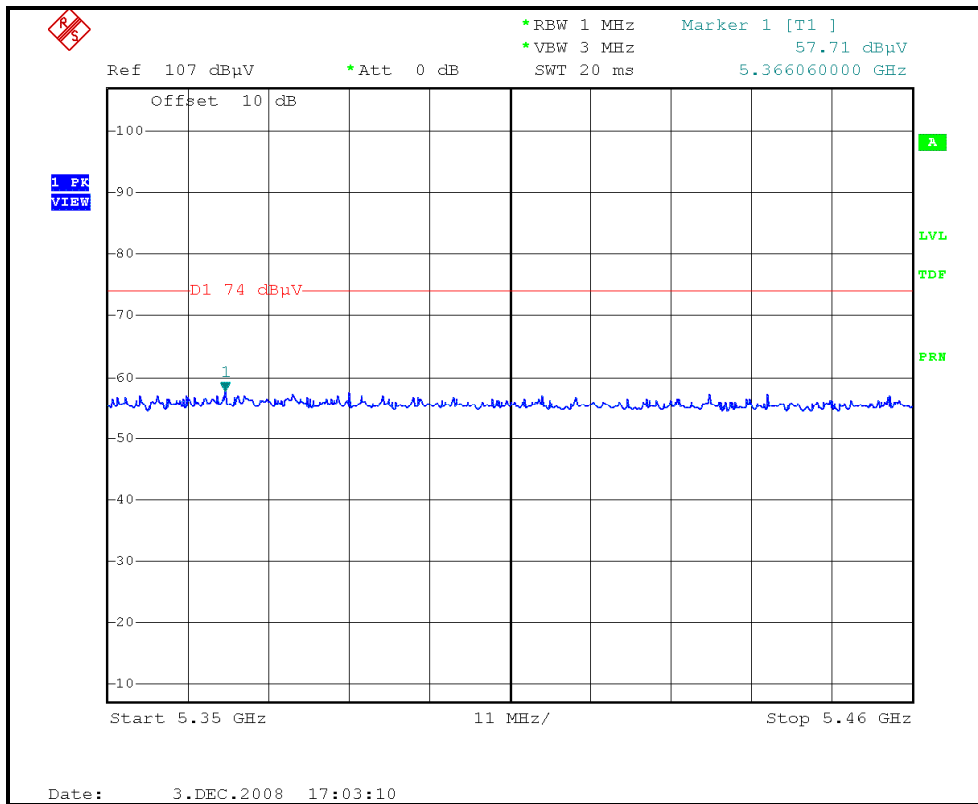



A D T

RESTRICTED BANDEDGE (DRAFT 802.11n (40MHz) MODE, CH2, VERTICAL)

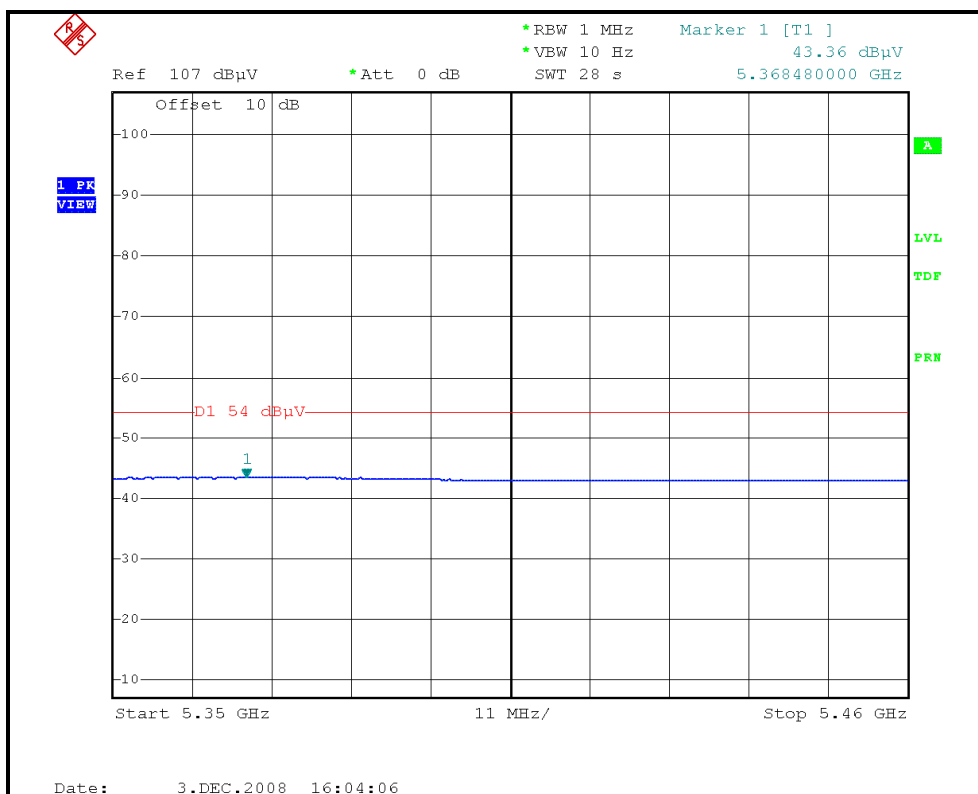
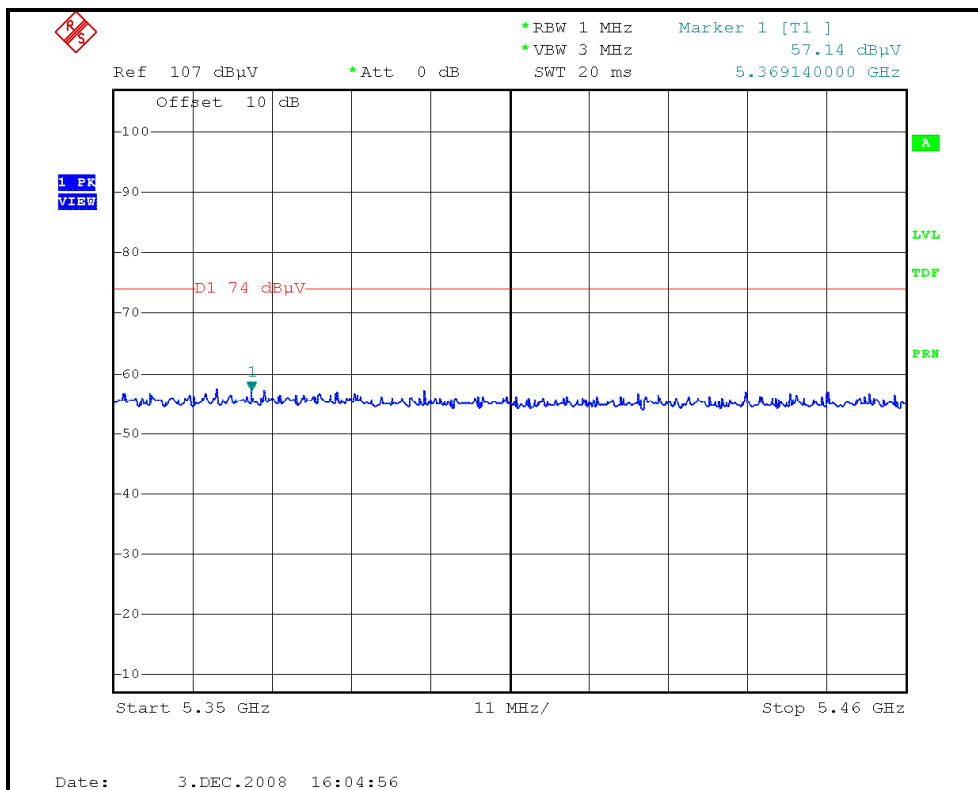

4.3 PEAK TRANSMIT POWER MEASUREMENT

4.3.1 LIMITS OF PEAK TRANSMIT POWER MEASUREMENT

Frequency Band	Limit
5.15 – 5.25GHz	The lesser of 50mW (17dBm) or 4dBm + 10logB
5.25 – 5.35GHz	The lesser of 250mW (24dBm) or 11dBm + 10logB
5.47 – 5.725GHz	The lesser of 250mW (24dBm) or 11dBm + 10logB
5.725 – 5.825GHz	The lesser of 1W (30dBm) or 17dBm + 10logB

NOTE: Where B is the 26dB emission bandwidth in MHz.

4.3.2 TEST INSTRUMENTS

DESCRIPTION & MANUFACTURER	MODEL NO.	SERIAL NO.	CALIBRATED DATE	CALIBRATED UNTIL
ADVANTEST SPECTRUM ANALYZER	U3772	160100280	July 26, 2008	July 25, 2009

NOTE:

- 1.The measurement uncertainty is less than +/- 2.6dB, which is calculated as per the NAMAS document NIS81.
- 2.The calibration interval of the above test instruments is 12 months and the calibrations are traceable to NML/ROC and NIST/USA.

4.3.3 TEST PROCEDURE

1. The transmitter output was connected to the spectrum analyzer.
2. Set span to encompass the entire emission bandwidth of the signal.
3. Set RBW to 1MHz, VBW to 300kHz.
4. Using the spectrum analyzer's channel power measurement function to measure the output power.

NOTE:

The test is performed in accordance with FCC Public Notice: APPENDIX A Guidelines for Assessing Unlicensed National Information Infrastructure (U-NII) Devices – Part 15, Subpart E, August 2002.

The transmitter output operates continuously therefore Method # 1 is used.

4.3.4 DEVIATION FROM TEST STANDARD

No deviation

4.3.5 TEST SETUP

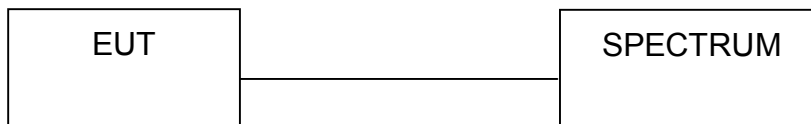

4.3.6 EUT OPERATING CONDITIONS

The software provided by client to enable the EUT under transmission condition continuously at specific channel frequencies individually.



4.3.7 TEST RESULTS

802.11a OFDM MODULATION:

MODULATION TYPE	BPSK	TRANSFER RATE	6Mbps
INPUT POWER	120Vac, 60 Hz	ENVIRONMENTAL CONDITIONS	25deg.C, 60%RH, 965hPa
TESTED BY	Rex Huang		

CHANNEL	CHANNEL FREQUENCY (MHz)	PEAK POWER OUTPUT (dBm)	PEAK POWER OUTPUT (mW)	PEAK POWER LIMIT (dBm)	26dBc Occupied Bandwidth (MHz)	PASS/FAIL
1	5180	13.50	22.4	17	26.36	PASS
2	5200	13.8	23.8	17	25.80	PASS
4	5240	14.3	26.9	17	26.21	PASS

NOTE: The 26dBc Occupied Bandwidth plot, please refer to the following pages.

Peak Power Output:
CH1

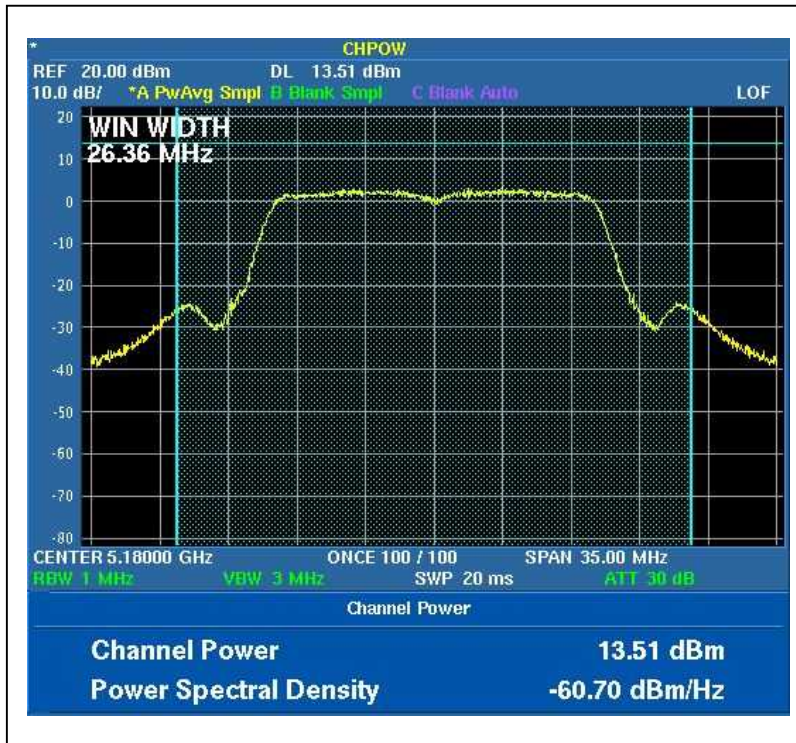

CH2





A D T

CH4





A D T

26dB Occupied Bandwidth: CH1

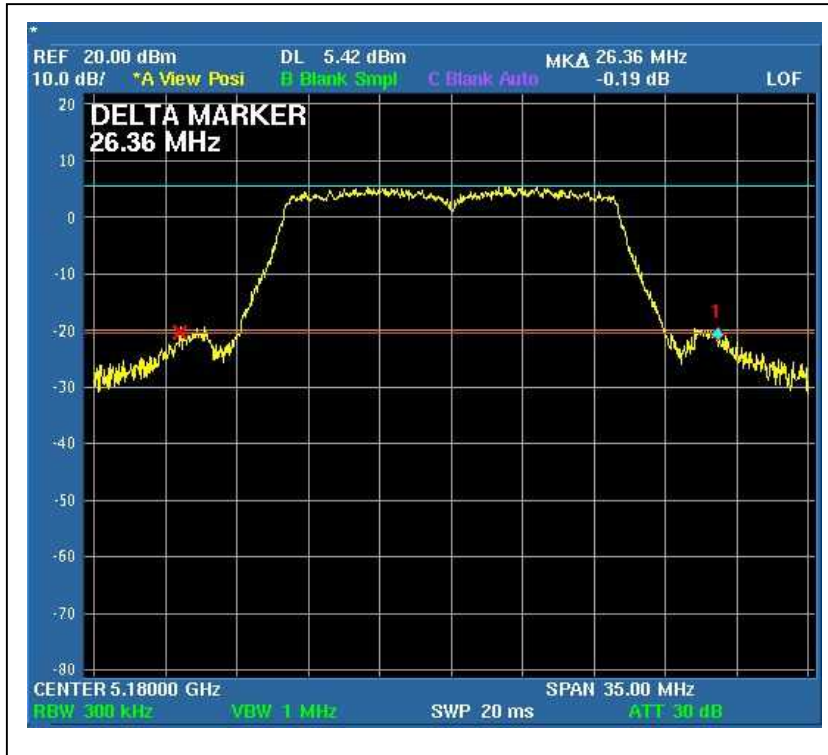

CH2

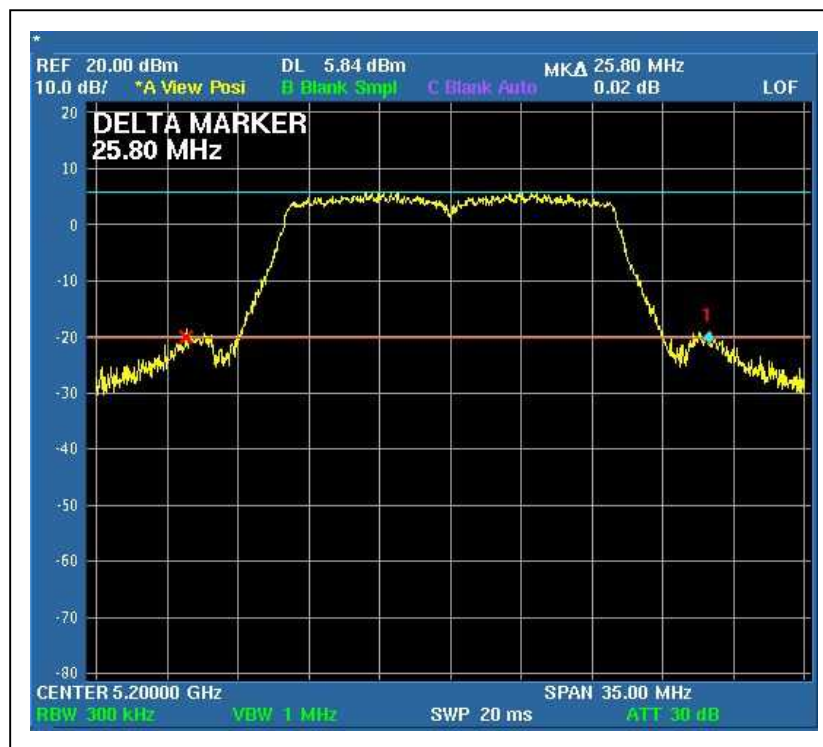



CH4

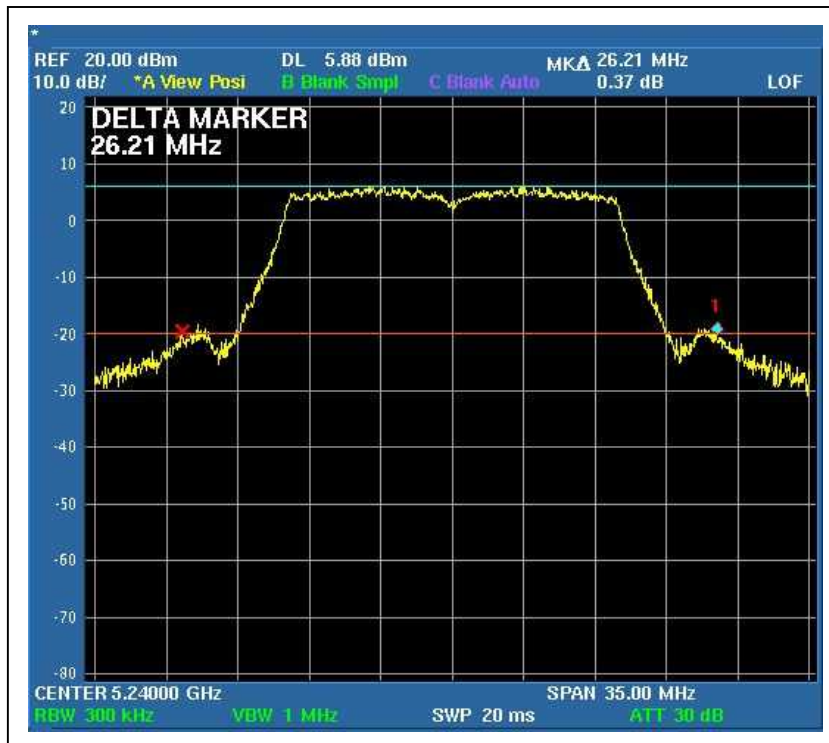



A D T

DRAFT 802.11n (20MHz) OFDM modulation:

MODULATION TYPE	BPSK	TRANSFER RATE	13Mbps
INPUT POWER	120Vac, 60 Hz	ENVIRONMENTAL CONDITIONS	25deg.C, 60%RH, 965hPa
TESTED BY	Rex Huang		

CHANNEL	CHANNEL FREQUENCY (MHz)	PEAK POWER OUTPUT (dBm)		TOTAL PEAK POWER (mW)	TOTAL PEAK POWER (dBm)	PEAK POWER LIMIT (dBm)	26dBc Occupied Bandwidth (MHz)		PASS/ FAIL
							Chain 0	Chain 1	
36	5180	11.3	11.2	26.7	14.3	17.00	25.16	21.39	PASS
40	5200	11.1	11.5	27.0	14.3	17.00	21.21	23.27	PASS
48	5240	11.2	10.9	25.5	14.1	17.00	25.38	24.99	PASS

NOTE: The 26dBc Occupied Bandwidth plot, please refer to the following pages.

Peak Power Output:
For Chain (0) :CH1

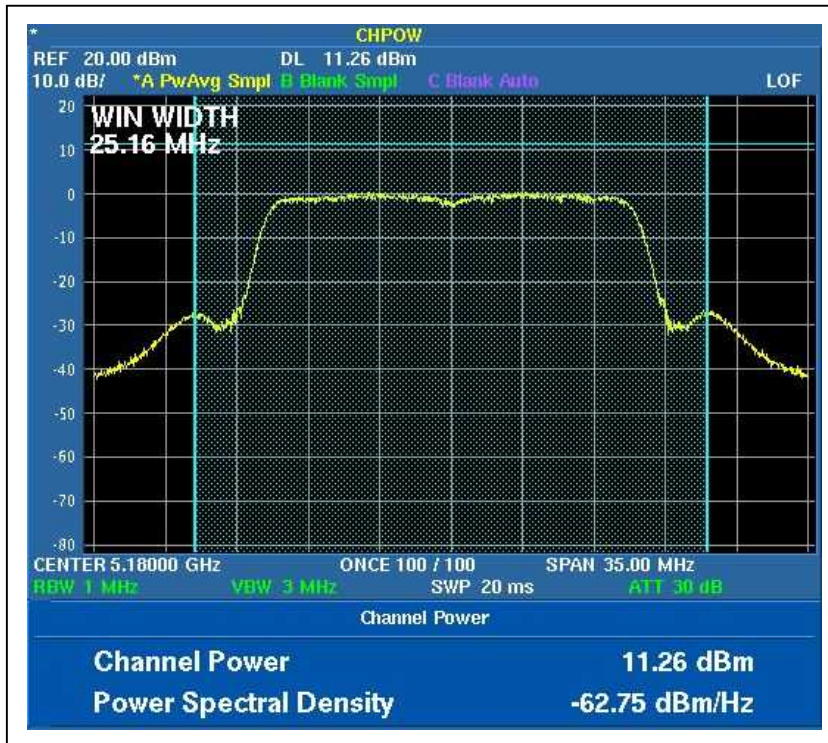

CH2

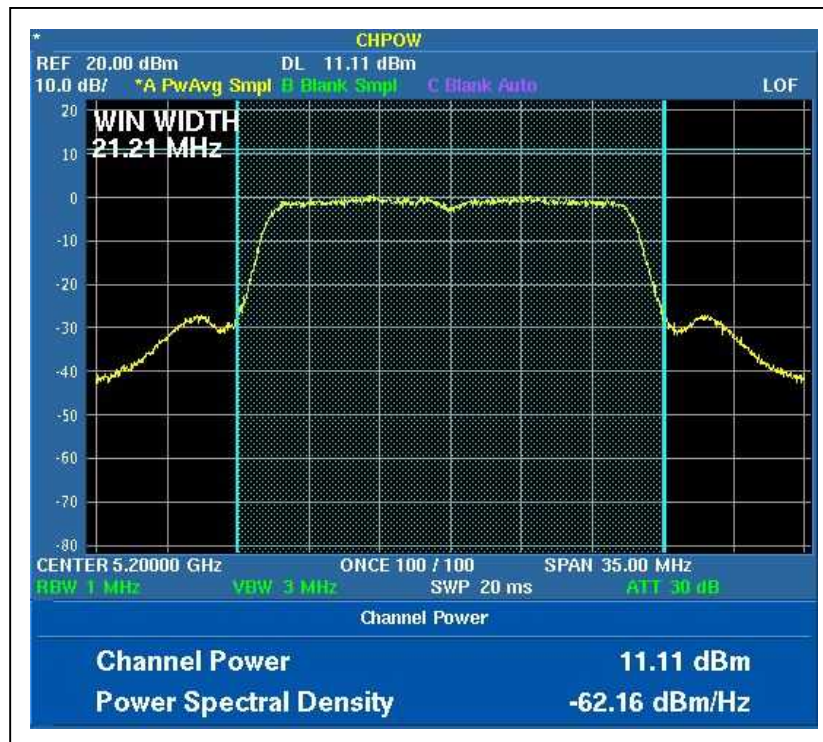



A D T

CH4





A D T

For Chain (1) :CH1

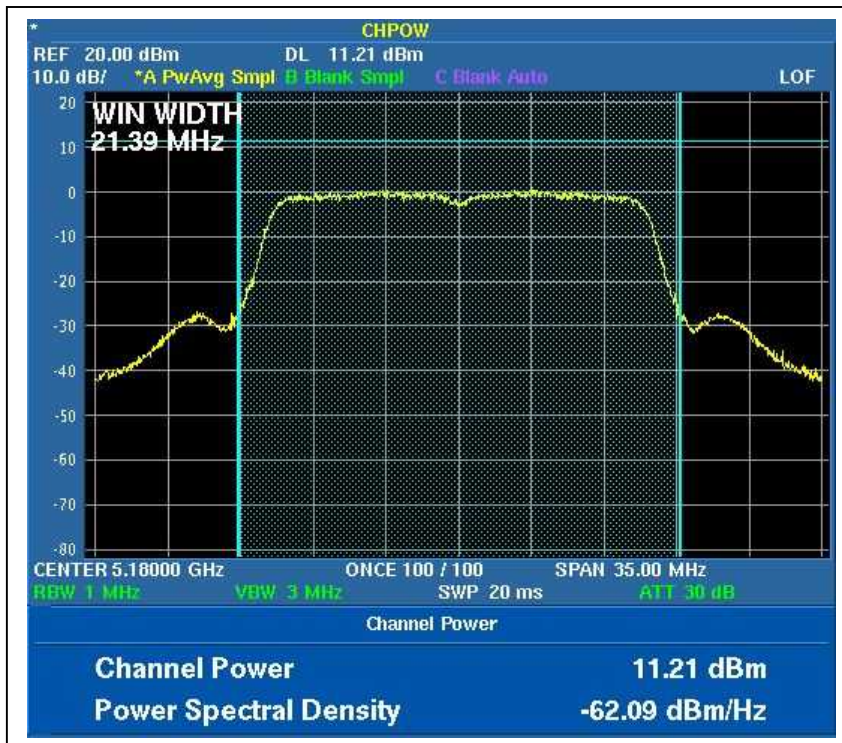

CH2





A D T

CH4

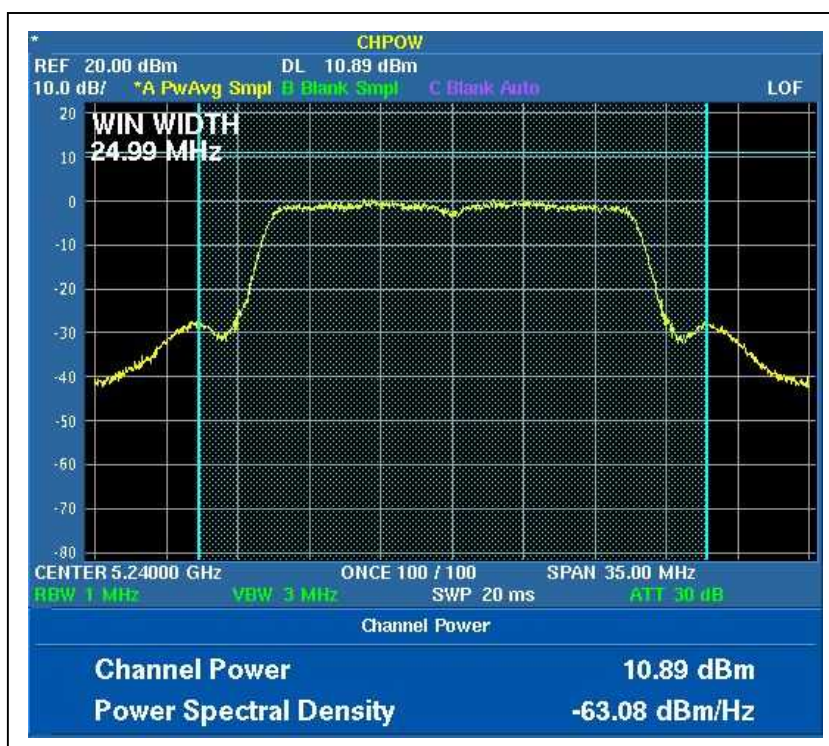

26dB Occupied Bandwidth:
For Chain (0) :CH1



CH2

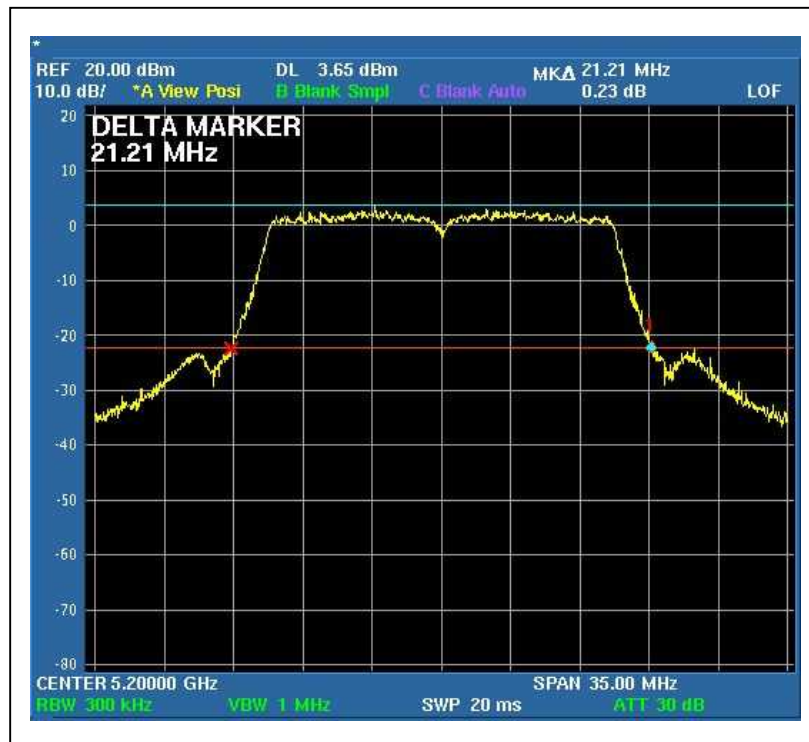



A D T

CH4

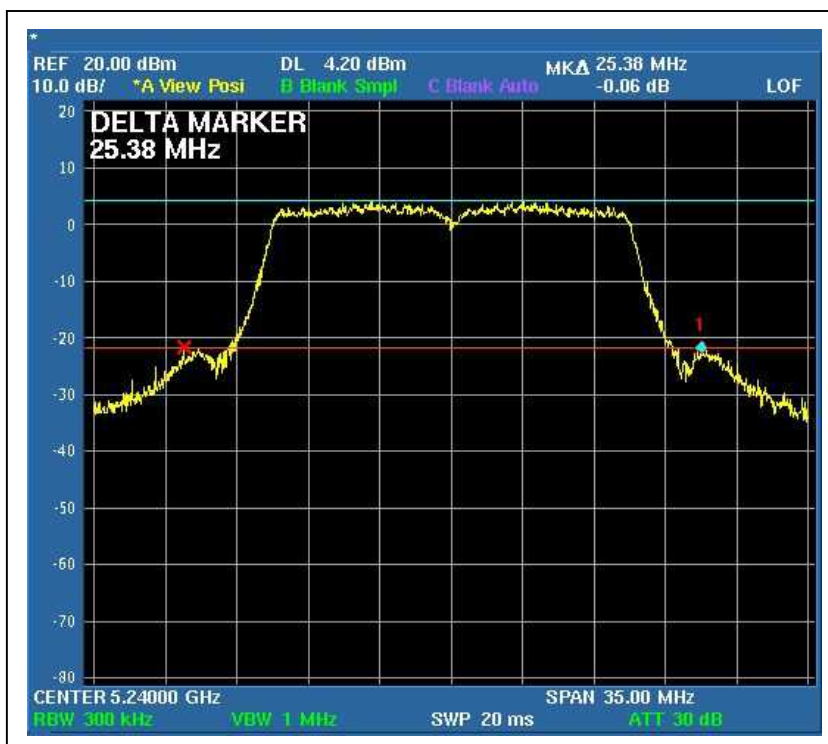



A D T

For Chain (1) :CH1

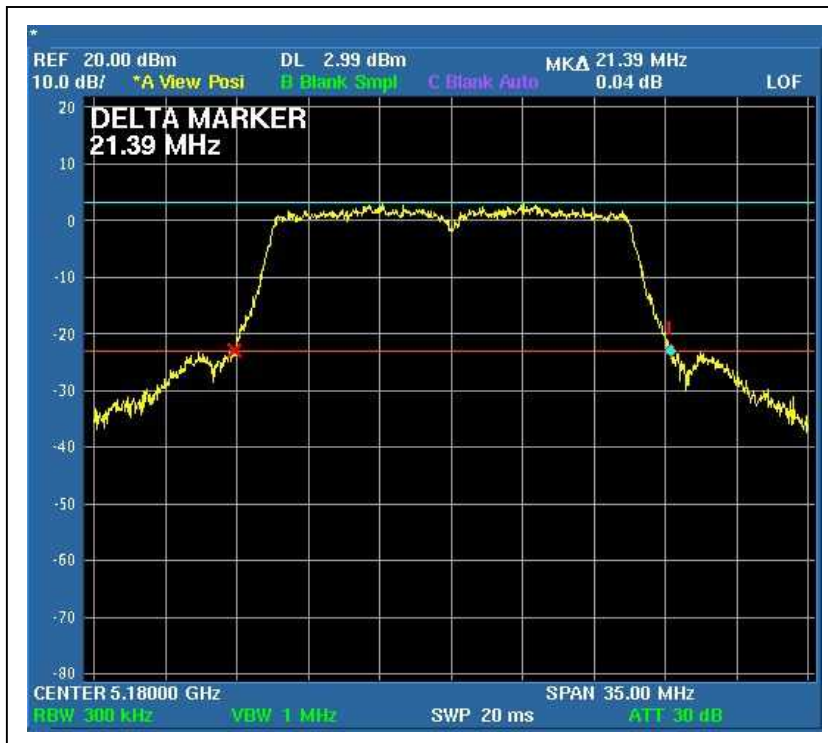

CH2





A D T

CH4

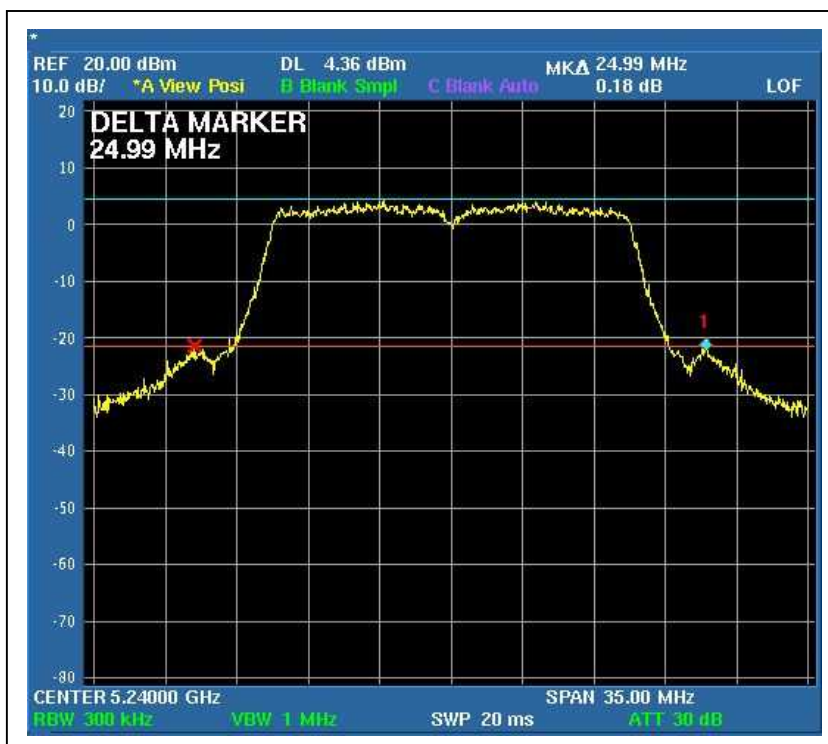



A D T

DRAFT 802.11n (40MHz) OFDM MODULATION:

MODULATION TYPE	BPSK	TRANSFER RATE	27Mbps
INPUT POWER	120Vac, 60 Hz	ENVIRONMENTAL CONDITIONS	25deg.C, 60%RH, 965hPa
TESTED BY	Wen Yu		

CHANNEL	CHANNEL FREQUENCY (MHz)	PEAK POWER OUTPUT (dBm)		TOTAL PEAK POWER (mW)	TOTAL PEAK POWER (dBm)	PEAK POWER LIMIT (dBm)	26dBc Occupied Bandwidth (MHz)		PASS/ FAIL
							Chain 0	Chain 1	
1	5190	13.2	12.3	37.9	15.8	17.00	44.31	39.55	PASS
2	5230	14.5	13.2	49.1	16.9	17.00	42.49	46.55	PASS

NOTE: The 26dBc Occupied Bandwidth plot, please refer to the following pages.



A D T

Peak Power Output:
For Chain (0) :CH1

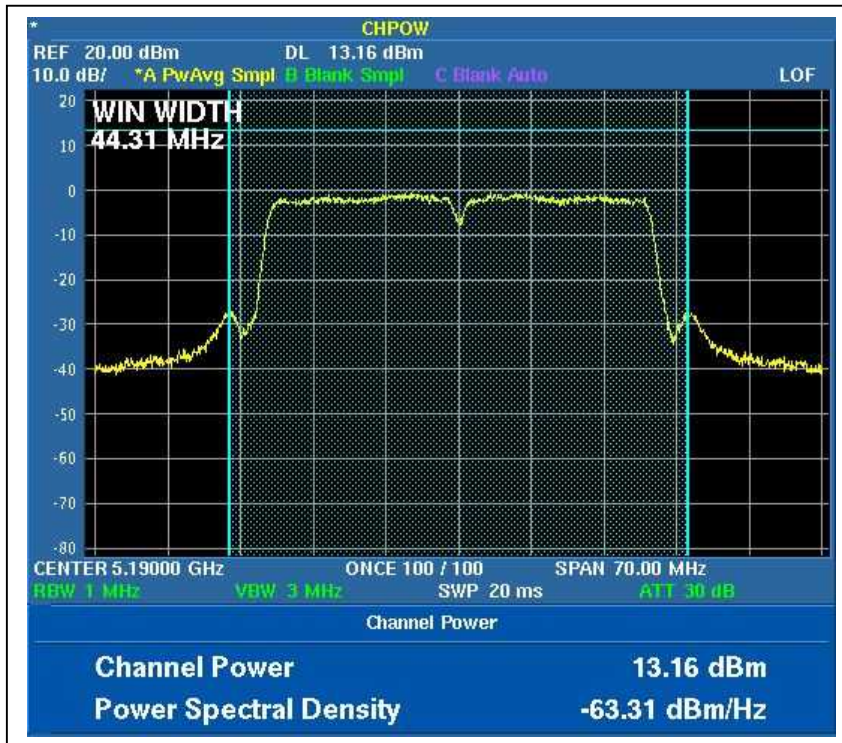

CH2

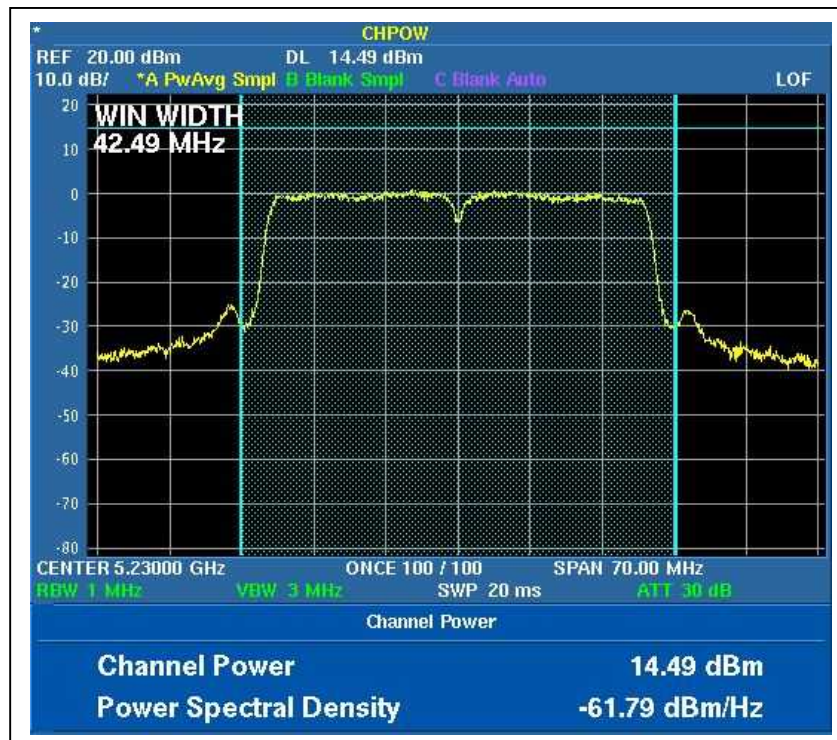

For Chain (1) :CH1

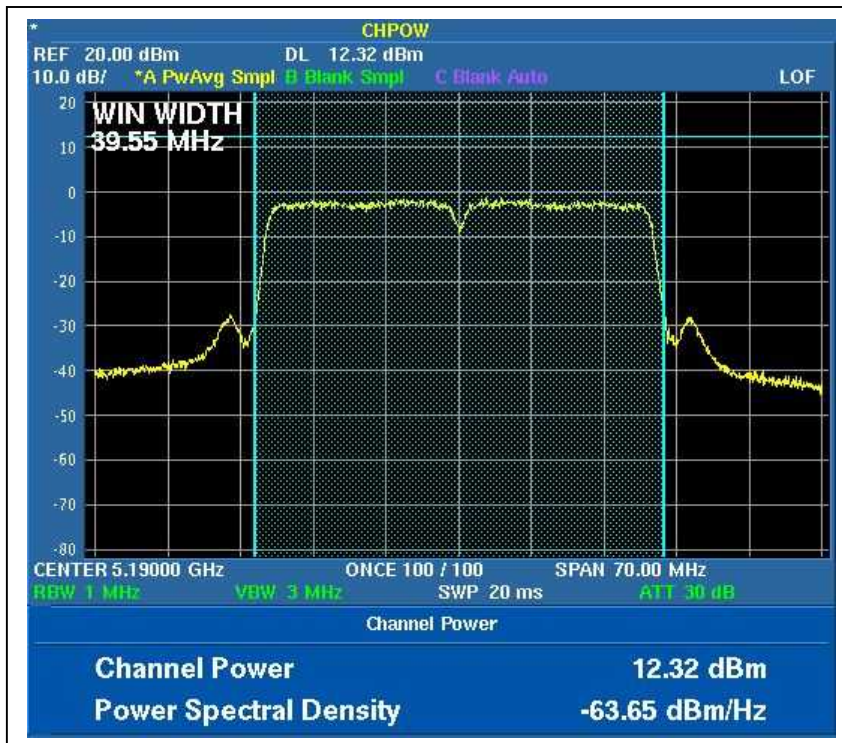

CH2

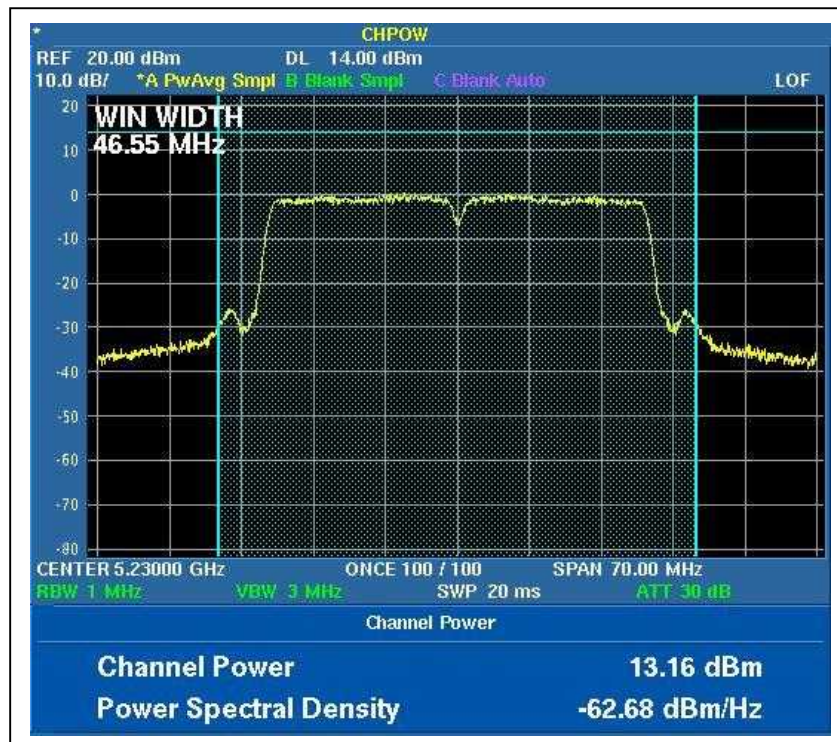



A D T

26dB Occupied Bandwidth:
For Chain (0) :CH1

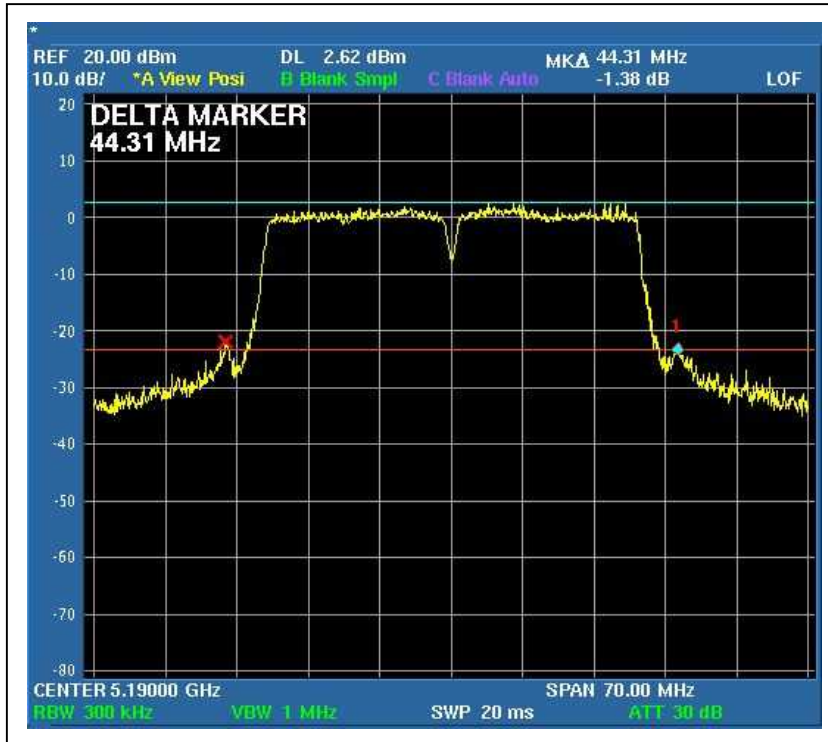

CH2

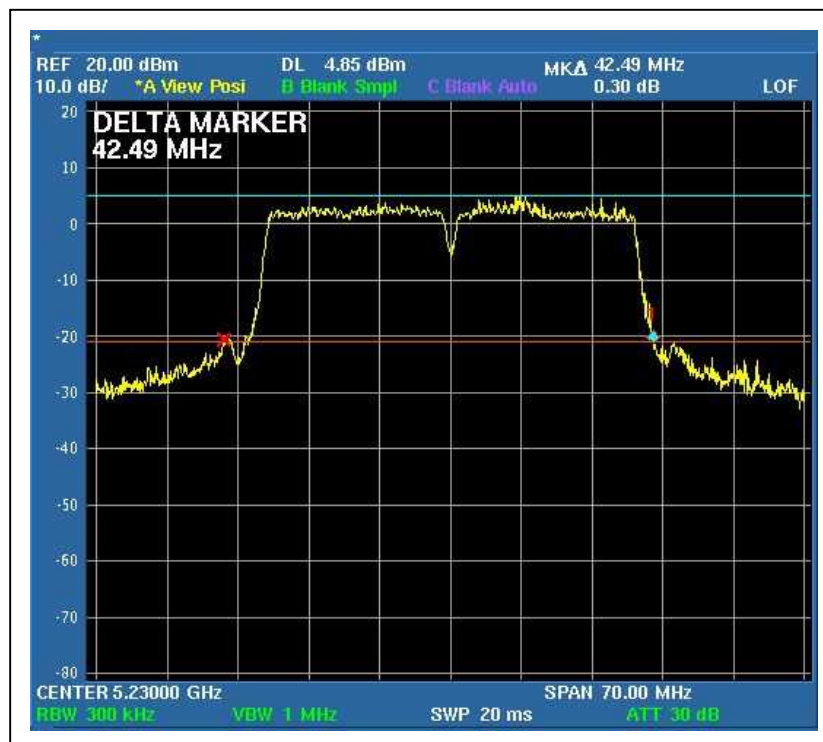

For Chain (1) :CH1



CH2

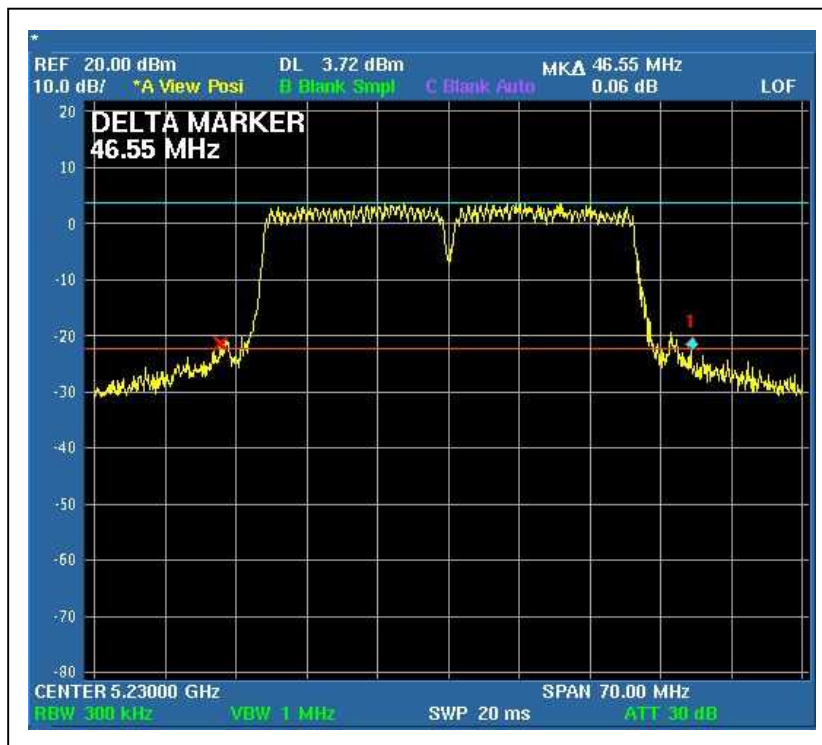



4.4 PEAK POWER EXCURSION MEASUREMENT

4.4.1 LIMITS OF PEAK POWER EXCURSION MEASUREMENT

Frequency Band	Limit
5.15 – 5.25 GHz	13dB
5.25 – 5.35 GHz	13dB
5.47 – 5.725GHz	13dB
5.725 – 5.825 GHz	13dB

4.4.2 TEST INSTRUMENTS

DESCRIPTION & MANUFACTURER	MODEL NO.	SERIAL NO.	CALIBRATED DATE	CALIBRATED UNTIL
R&S SPECTRUM ANALYZER	FSP40	100037	Aug. 09, 2008	Aug. 08, 2009

NOTE:

- 1.The measurement uncertainty is less than +/- 2.6dB, which is calculated as per the NAMAS document NIS81. This uncertainty represents an expanded uncertainty expressed at approximately the 95% confidence level using a coverage factor of k=2.
- 2.The calibration interval of the above test instruments is 12 months and the calibrations are traceable to NML/ROC and NIST/USA.

4.4.3 TEST PROCEDURE

1. The transmitter output was connected to the spectrum analyzer.
2. Set the spectrum bandwidth span to view the entire spectrum.
3. Using peak detector and Max-hold function for Trace 1 (RB=1MHz, VB=3MHz) and 2 (RB=1MHz, VB=300KHz).
4. The largest difference between Trace 1 and Trace 2 in any 1MHz band on any frequency was recorded.

4.4.4 DEVIATION FROM TEST STANDARD

No deviation

4.4.5 TEST SETUP

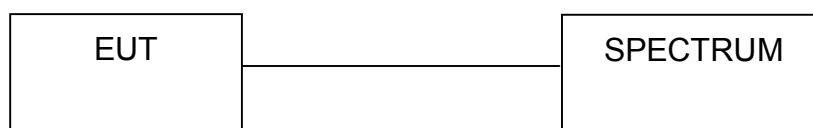

4.4.6 EUT OPERATING CONDITIONS

The software provided by client to enable the EUT under transmission condition continuously at specific channel frequencies individually.



A D T

4.4.7 TEST RESULTS

802.11a OFDM modulation

MODULATION TYPE	BPSK	TRANSFER RATE	6Mbps
INPUT POWER	120Vac, 60 Hz	ENVIRONMENTAL CONDITIONS	25deg.C, 60%RH, 965hPa
TESTED BY	Wen Yu		

CHANNEL	CHANNEL FREQUENCY (MHz)	PEAK POWER EXCURSION (dB)	PEAK to AVERAGE EXCURSION LIMIT (dB)	PASS/FAIL
1	5180	9.22	13	PASS
2	5200	9.77	13	PASS
4	5240	10.08	13	PASS



A D T

CH1

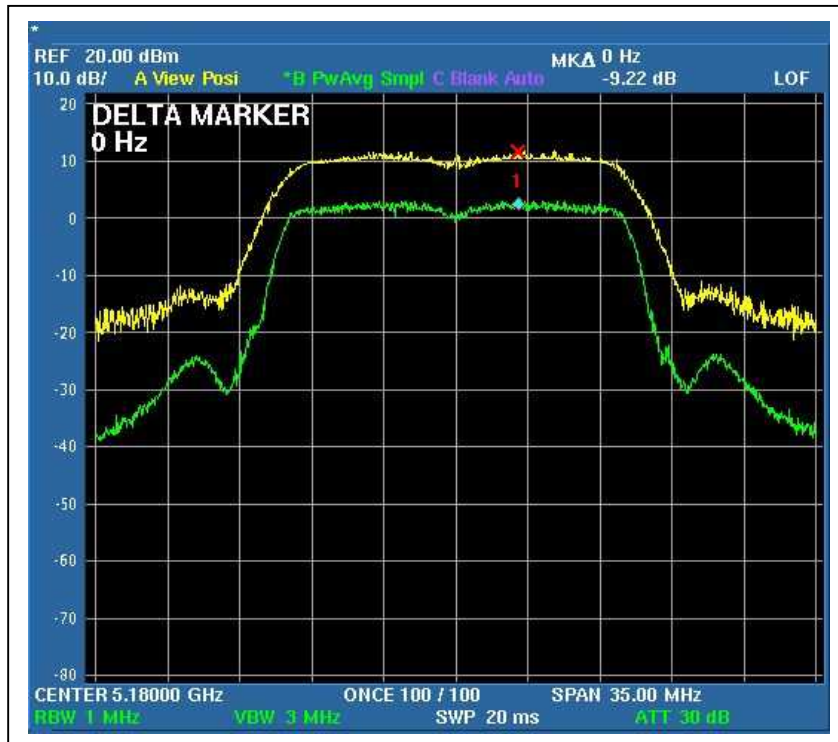

CH2

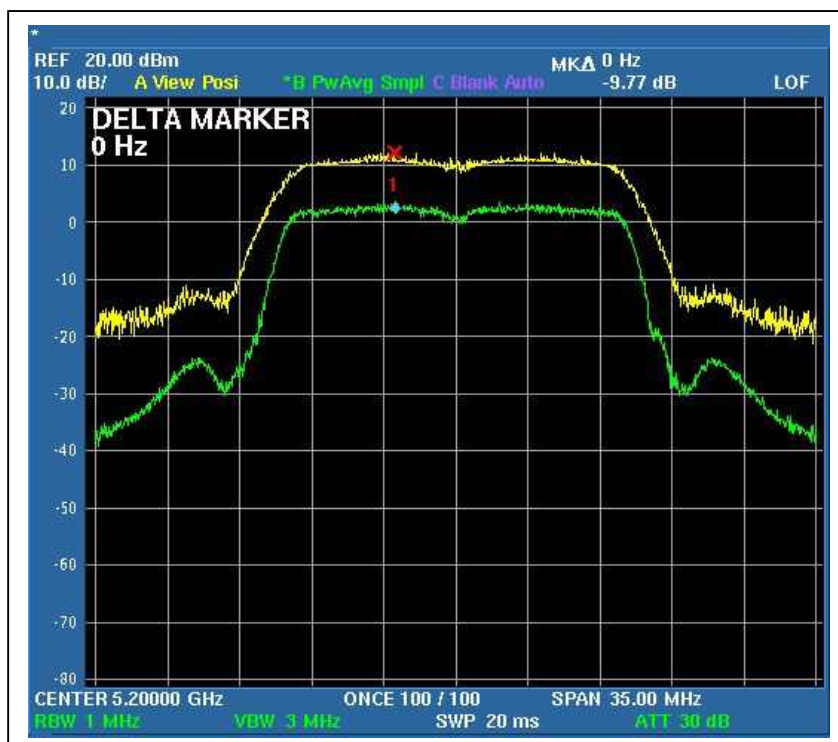



A D T

CH4

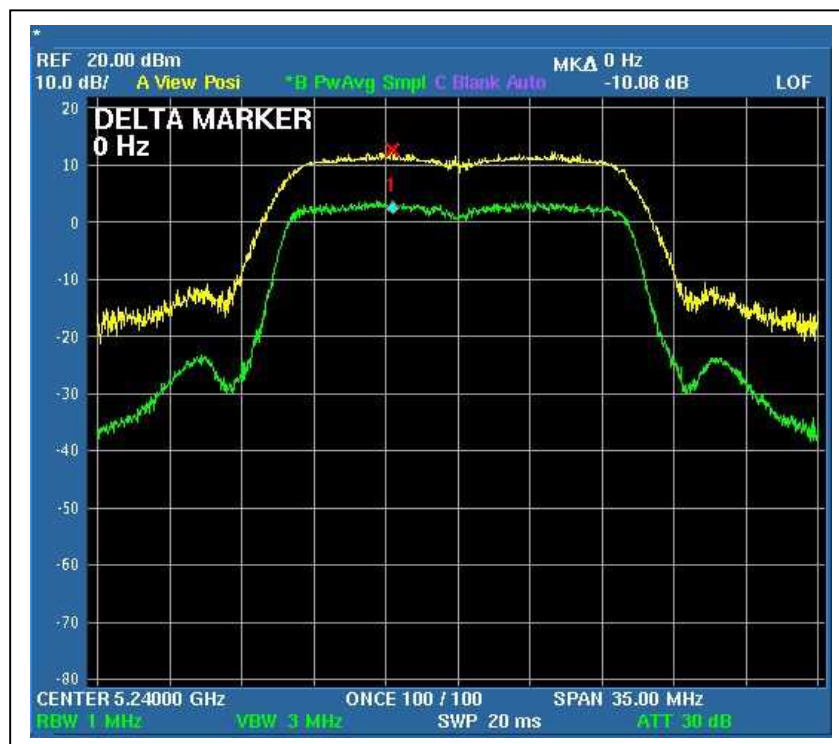



A D T

DRAFT 802.11n (20MHz) OFDM MODULATION:

MODULATION TYPE	BPSK	TRANSFER RATE	13Mbps
INPUT POWER	120Vac, 60 Hz	ENVIRONMENTAL CONDITIONS	25deg.C, 60%RH, 965hPa
TESTED BY	Wen Yu		

CHANNEL	CHANNEL FREQUENCY (MHz)	PEAK POWER EXCURSION (dB)		PEAK to AVERAGE EXCURSION LIMIT (dB)	PASS/FAIL
		Chain (0)	Chain(1)		
1	5180	9.70	11.48	13	PASS
2	5200	9.41	8.57	13	PASS
4	5240	10.85	12.16	13	PASS



A D T

For Chain (0) : CH1



CH2

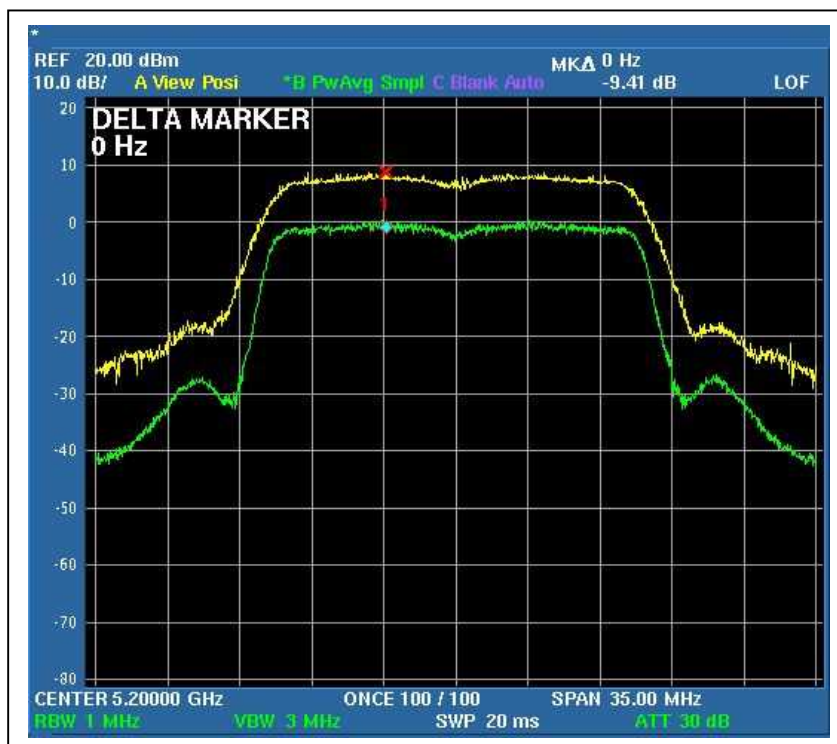



A D T

CH4



For Chain (1) : CH1

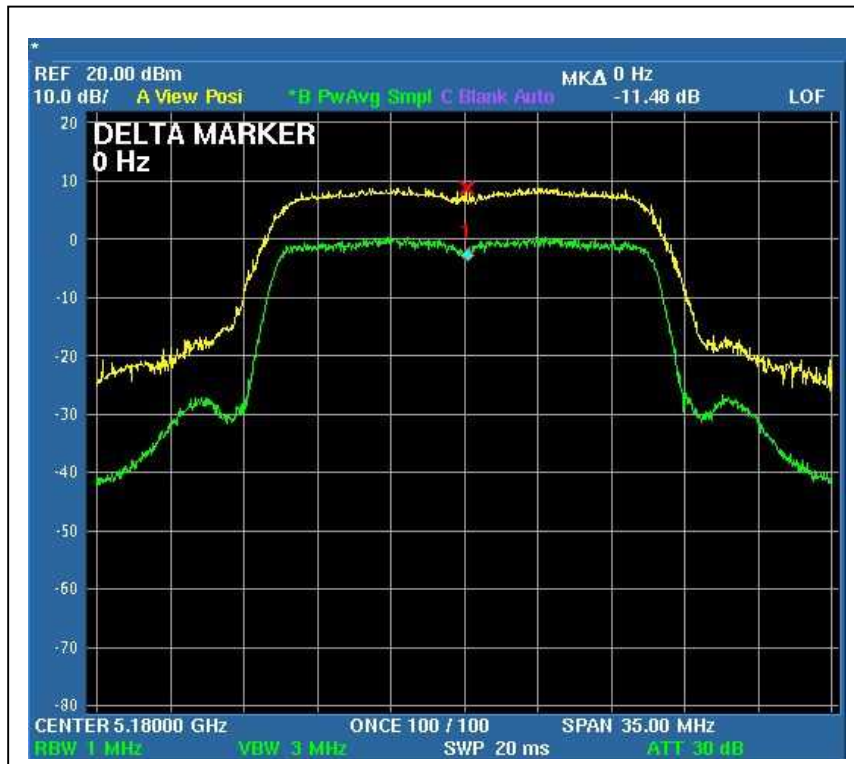

CH2

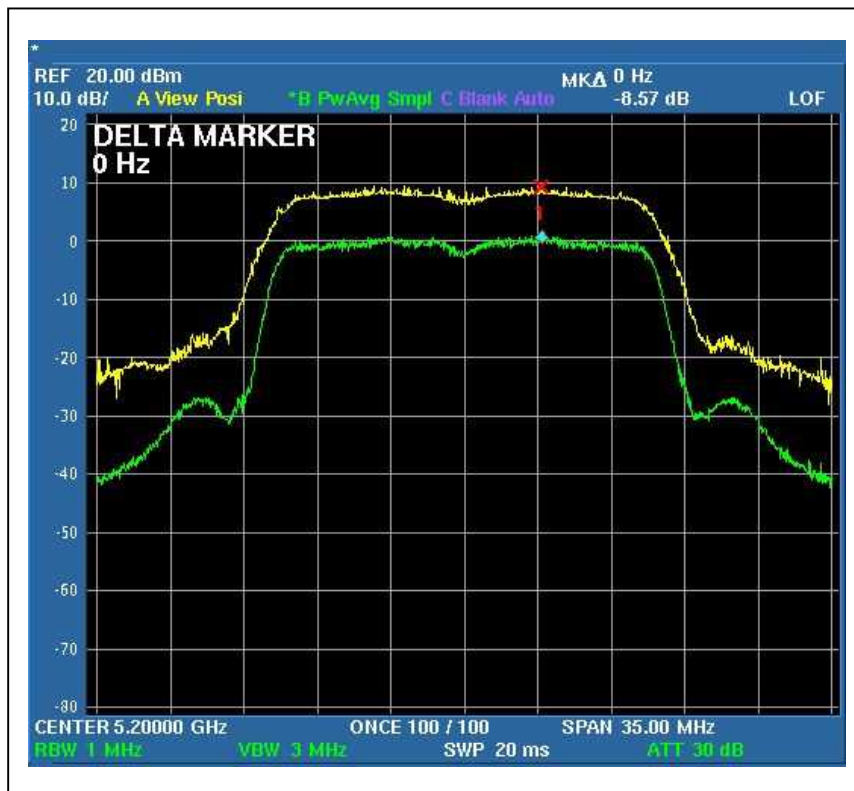



A D T

CH4

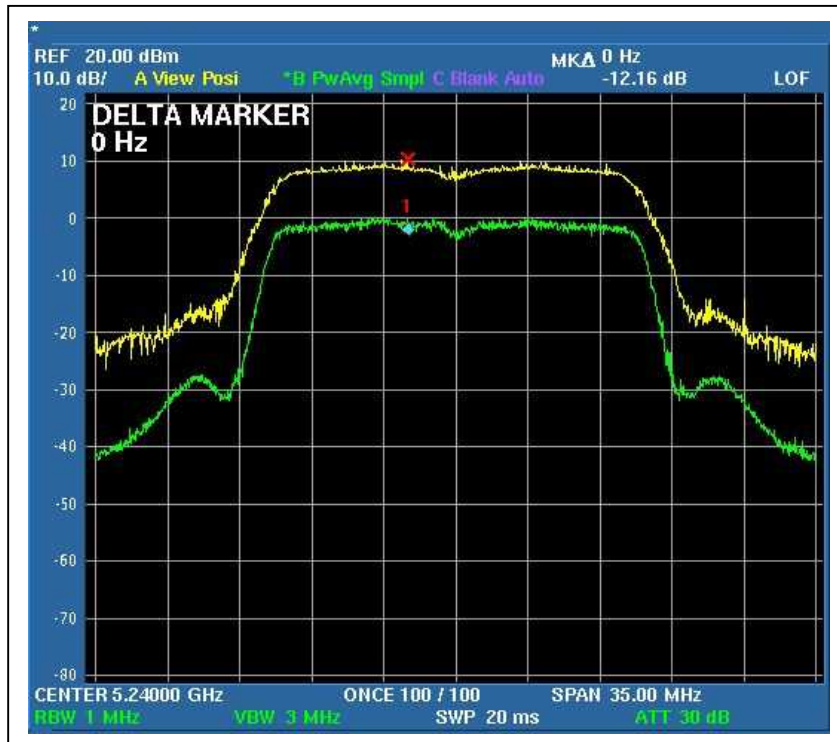



A D T

DRAFT 802.11n (40MHz) OFDM MODULATION:

MODULATION TYPE	BPSK	TRANSFER RATE	27Mbps
INPUT POWER	120Vac, 60 Hz	ENVIRONMENTAL CONDITIONS	25deg.C, 60%RH, 965hPa
TESTED BY	Wen Yu		

CHANNEL	CHANNEL FREQUENCY (MHz)	PEAK POWER EXCURSION (dB)		PEAK to AVERAGE EXCURSION LIMIT (dB)	PASS/FAIL
		Chain (0)	Chain(1)		
1	5190	11.47	11.16	13	PASS
2	5230	11.58	11.25	13	PASS



A D T

For Chain (0) : CH1



CH2

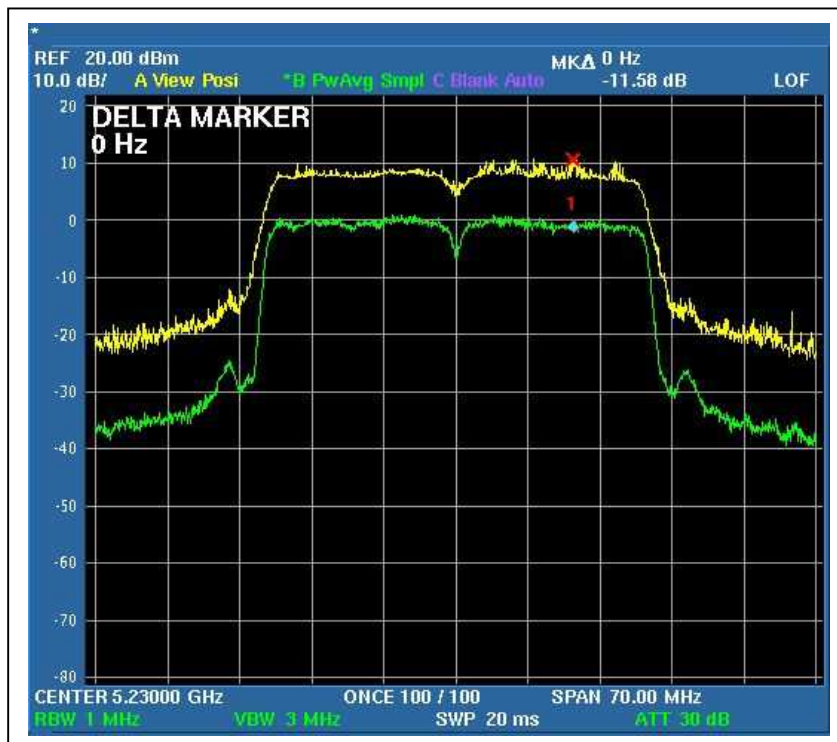



A D T

For Chain (1) : CH1

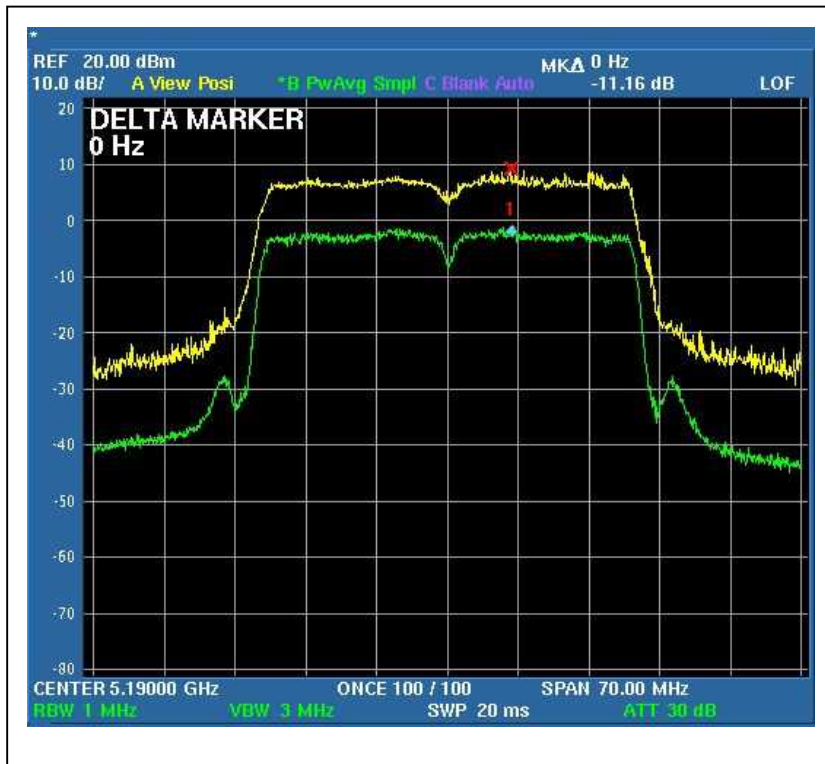

CH2

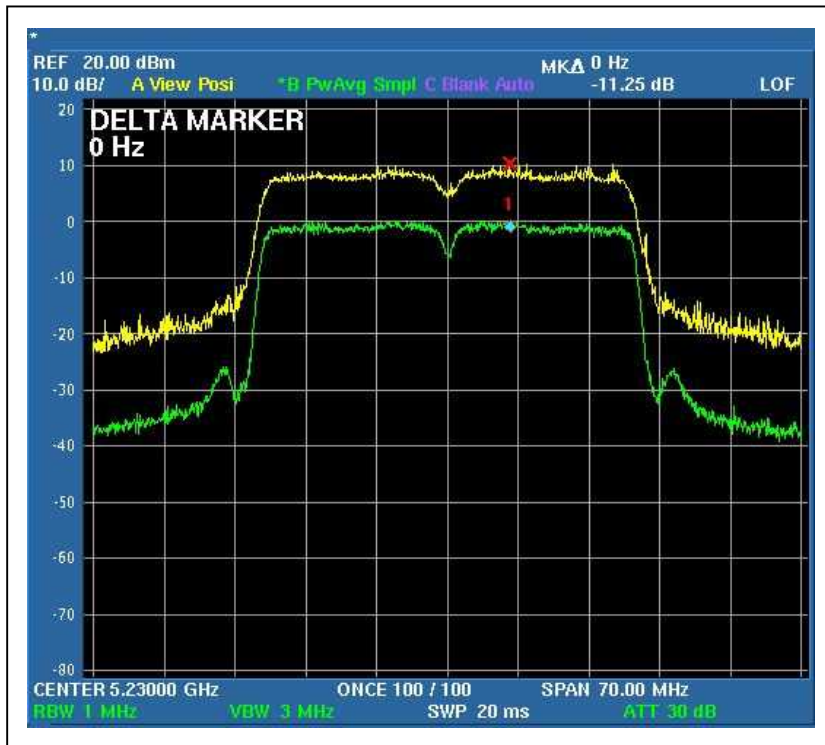



A D T

4.5 PEAK POWER SPECTRAL DENSITY MEASUREMENT

4.5.1 LIMITS OF PEAK POWER SPECTRAL DENSITY MEASUREMENT

Frequency Band	Limit
5.15 ~ 5.25GHz	4dBm
5.25 ~ 5.35GHz	11dBm
5.47 – 5.725GHz	11dBm
5.725 ~ 5.825GHz	17dBm

4.5.2 TEST INSTRUMENTS

DESCRIPTION & MANUFACTURER	MODEL NO.	SERIAL NO.	CALIBRATED DATE	CALIBRATED UNTIL
R&S SPECTRUM ANALYZER	FSP40	100037	Aug. 09, 2008	Aug. 08, 2009

NOTE:

- 1.The measurement uncertainty is less than +/- 2.6dB, which is calculated as per the NAMAS document NIS81. This uncertainty represents an expanded uncertainty expressed at approximately the 95% confidence level using a coverage factor of k=2.
- 2.The calibration interval of the above test instruments is 12 months and the calibrations are traceable to NML/ROC and NIST/USA.



4.5.3 TEST PROCEDURES

1. The transmitter output was connected to the spectrum analyzer.
2. Set RBW=1MHz, VBW=3MHz. The PPSD is the highest level found across the emission in any 1MHz band.

4.5.4 DEVIATION FROM TEST STANDARD

No deviation

4.5.5 TEST SETUP

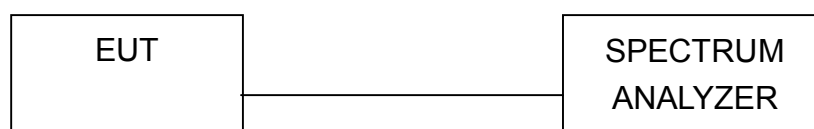

4.5.6 EUT OPERATING CONDITIONS

Same as 4.3.6



4.5.7 TEST RESULTS

802.11a OFDM modulation

MODULATION TYPE	BPSK	TRANSFER RATE	6Mbps
INPUT POWER	120Vac, 60 Hz	ENVIRONMENTAL CONDITIONS	25deg.C, 60%RH, 965hPa
TESTED BY	Wen Yu		

CHANNEL	CHANNEL FREQUENCY (MHz)	RF POWER LEVEL IN 1MHz BW (dBm)	MAXIMUM LIMIT (dBm)	PASS/FAIL
1	5180	3.4	4	PASS
2	5200	3.2	4	PASS
4	5240	3.8	4	PASS



A D T

CH1

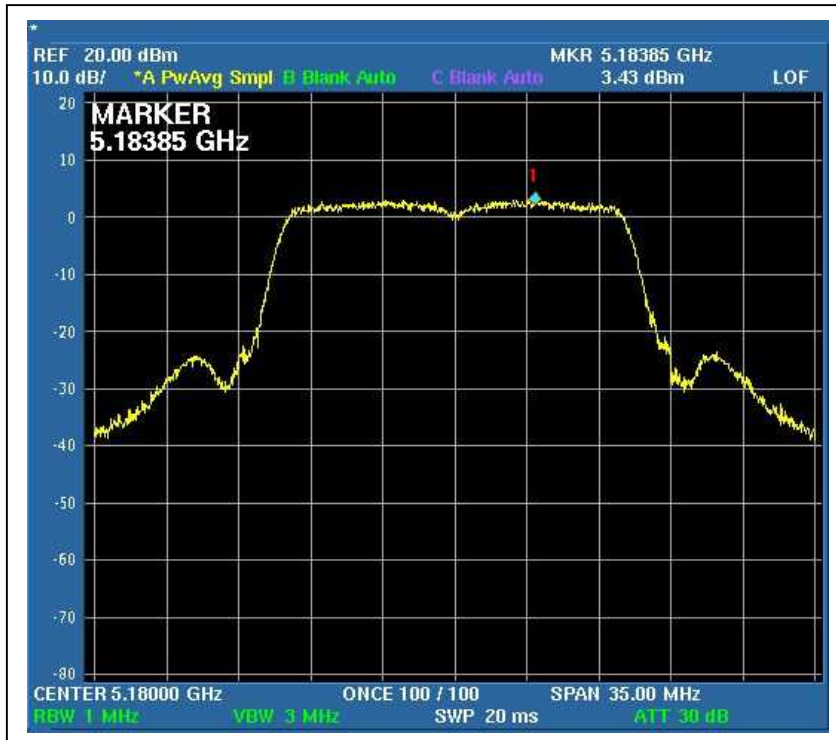

CH2

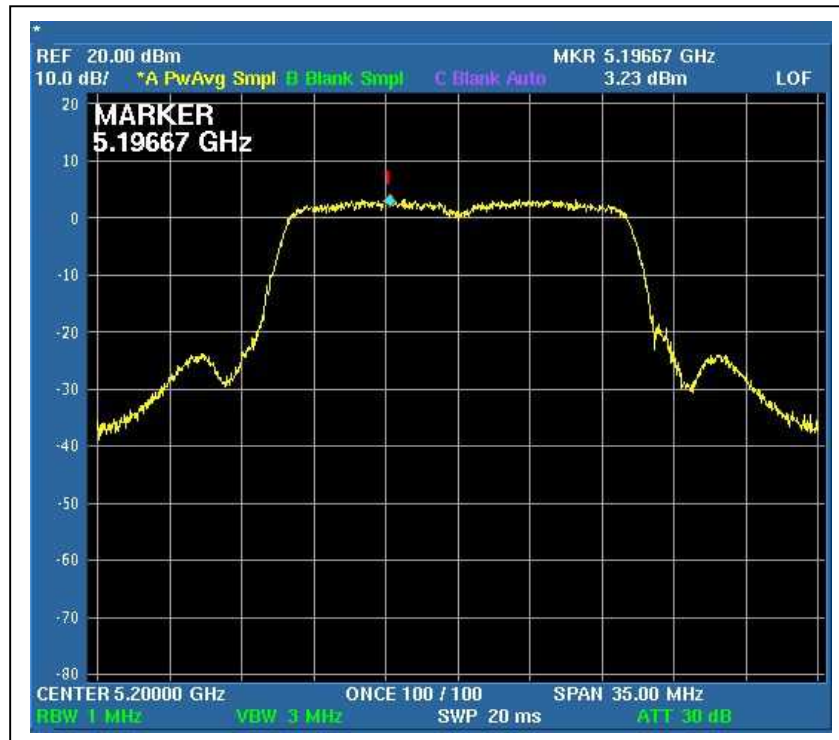



A D T

CH4





A D T

DRAFT 802.11n (20MHz) OFDM MODULATION:

MODULATION TYPE	BPSK	TRANSFER RATE	13Mbps
INPUT POWER	120Vac, 60 Hz	ENVIRONMENTAL CONDITIONS	25deg.C, 60%RH, 965hPa
TESTED BY	Wen Yu		

CHANNEL	CHANNEL FREQUENCY (MHz)	RF POWER LEVEL IN 1MHz BW (dBm)		TOTAL OUTPUT POWER DENSITY (dBm)	MAXIMUM LIMIT (dBm)	PASS/FAIL
		Chain (0)	Chain(1)			
1	5180	0.6	0.4	3.4	4	PASS
2	5200	0.2	0.8	3.4	4	PASS
4	5240	0.5	0.1	3.2	4	PASS



A D T

For Chain (0) : CH1

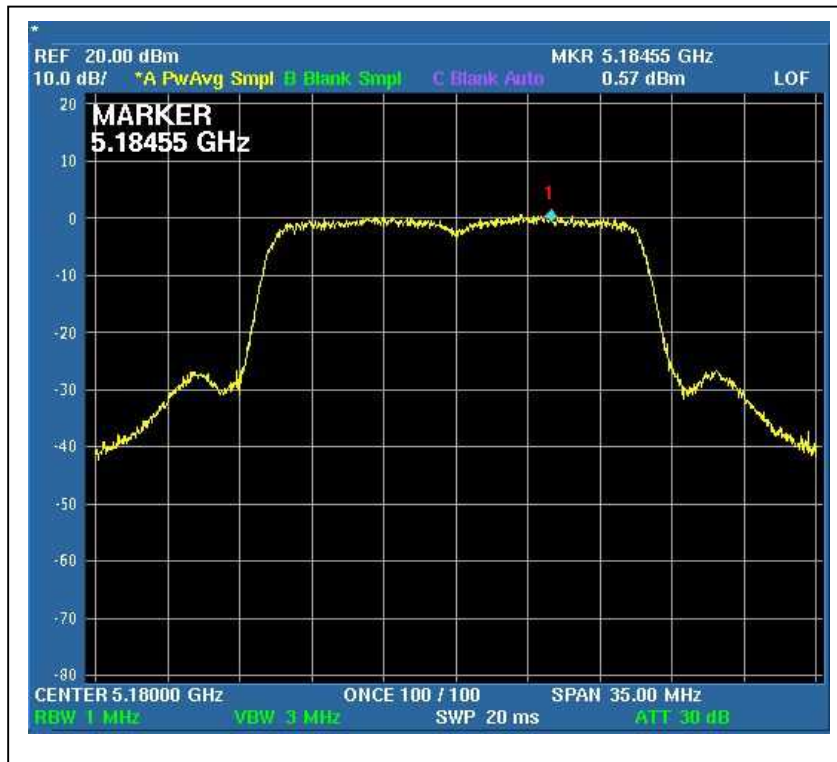

CH2

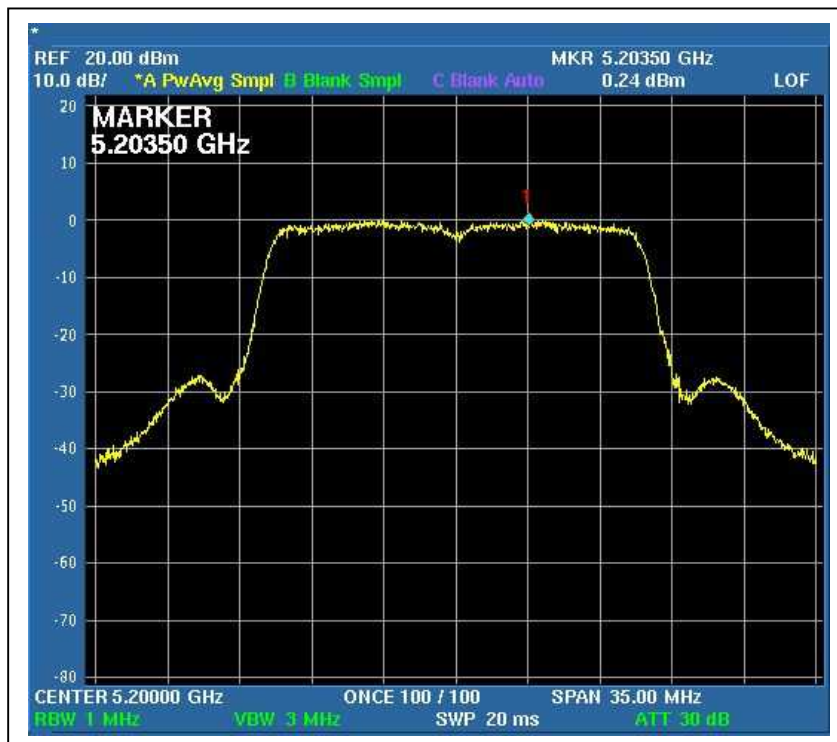



A D T

CH4

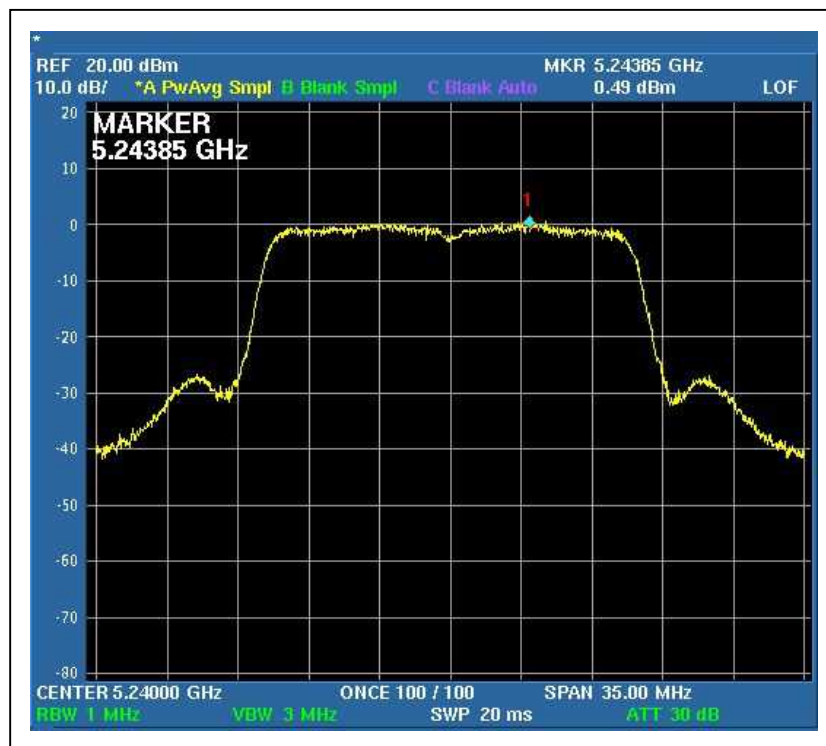



A D T

For Chain (1) : CH1

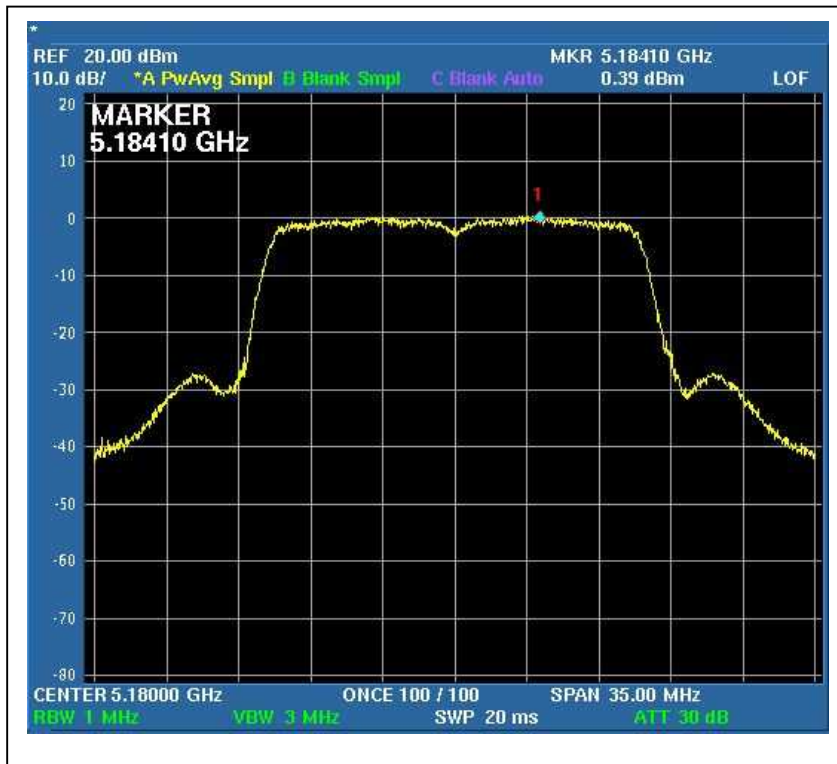

CH2

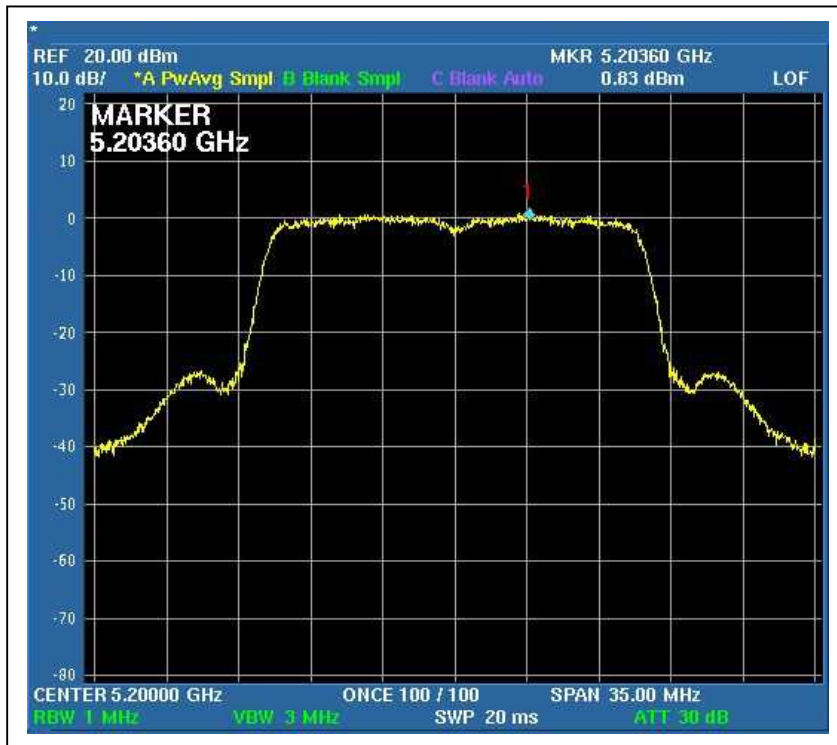



A D T

CH4

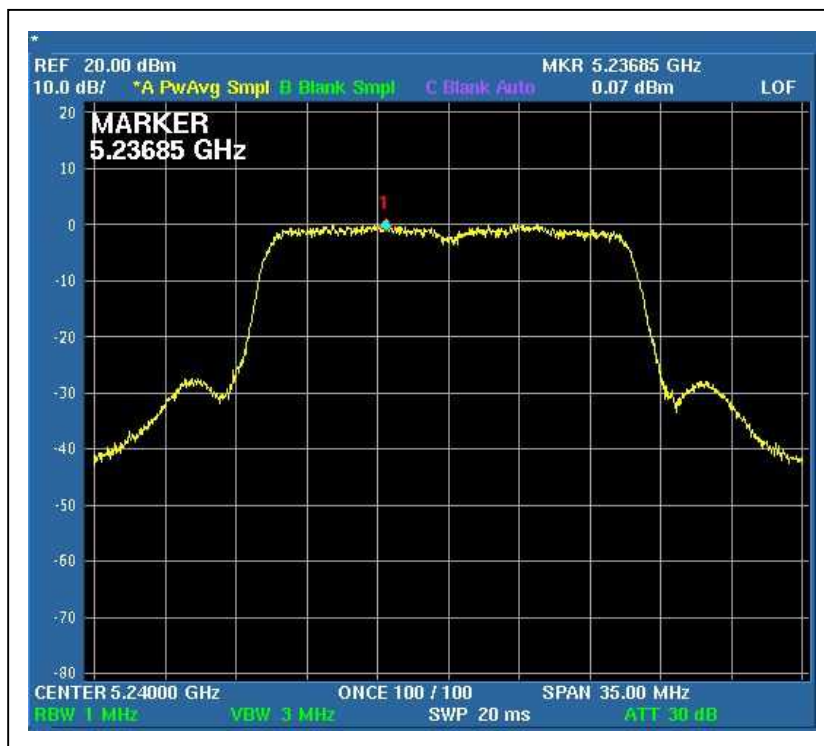



A D T

DRAFT 802.11n (40MHz) OFDM MODULATION:

MODULATION TYPE	BPSK	TRANSFER RATE	27Mbps
INPUT POWER	120Vac, 60 Hz	ENVIRONMENTAL CONDITIONS	25deg.C, 60%RH, 965hPa
TESTED BY	Wen Yu		

CHANNEL	CHANNEL FREQUENCY (MHz)	RF POWER LEVEL IN 1MHz BW (dBm)		TOTAL OUTPUT POWER DENSITY (dBm)	MAXIMUM LIMIT (dBm)	PASS/FAIL
		Chain (0)	Chain(1)			
1	5190	-0.4	-1.3	2.3	4	PASS
2	5230	0.8	0.02	3.0	4	PASS



A D T

For Chain (0) : CH1

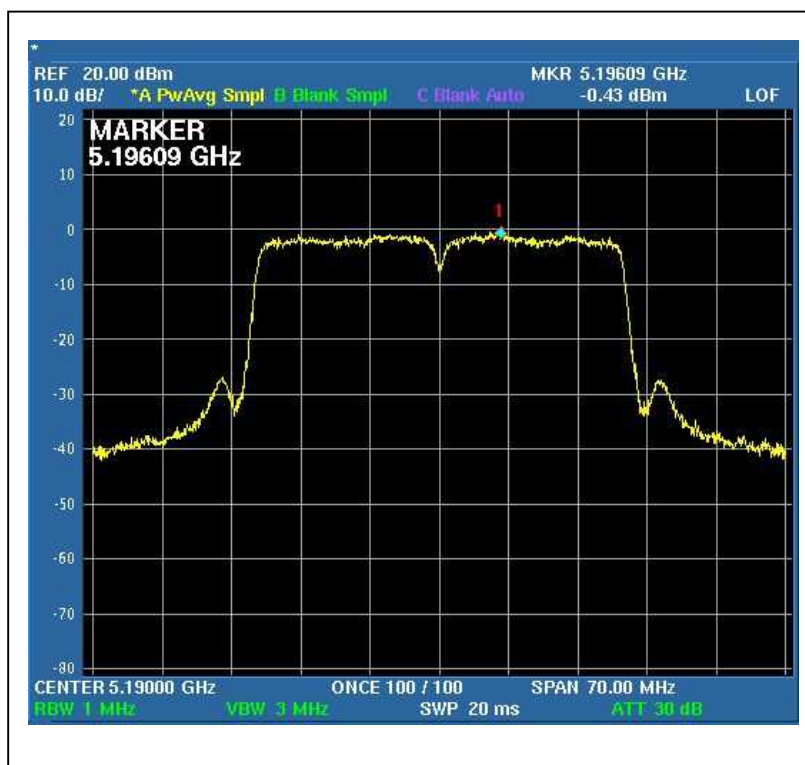

CH2

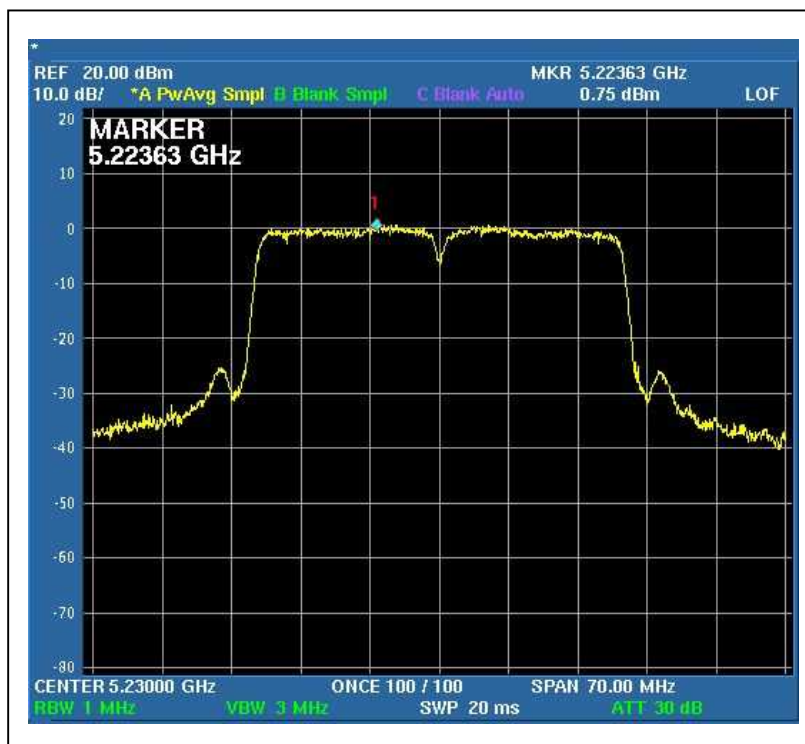



A D T

For Chain (1) : CH1

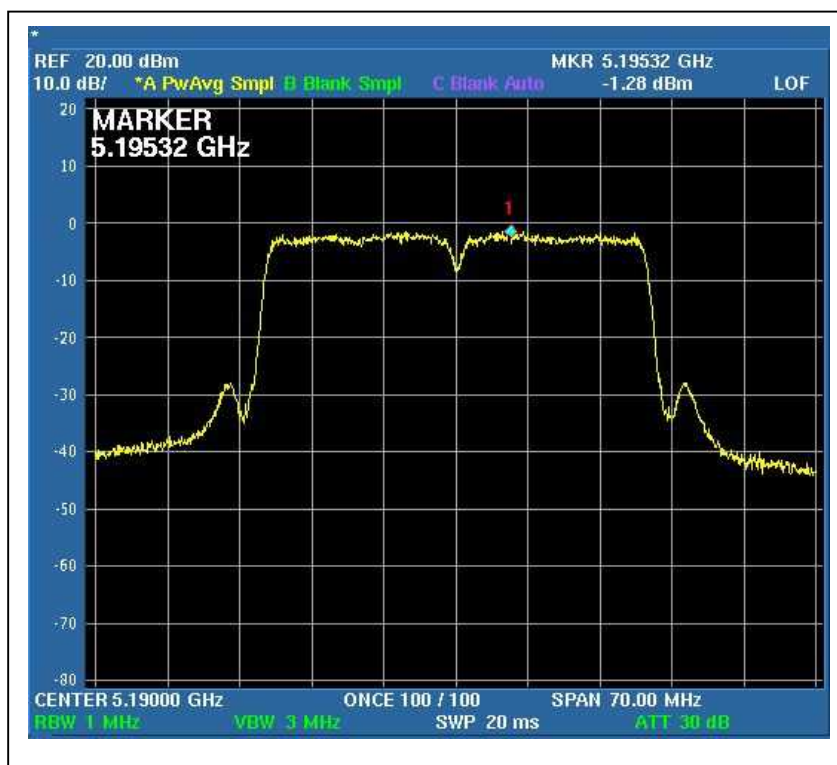

CH2

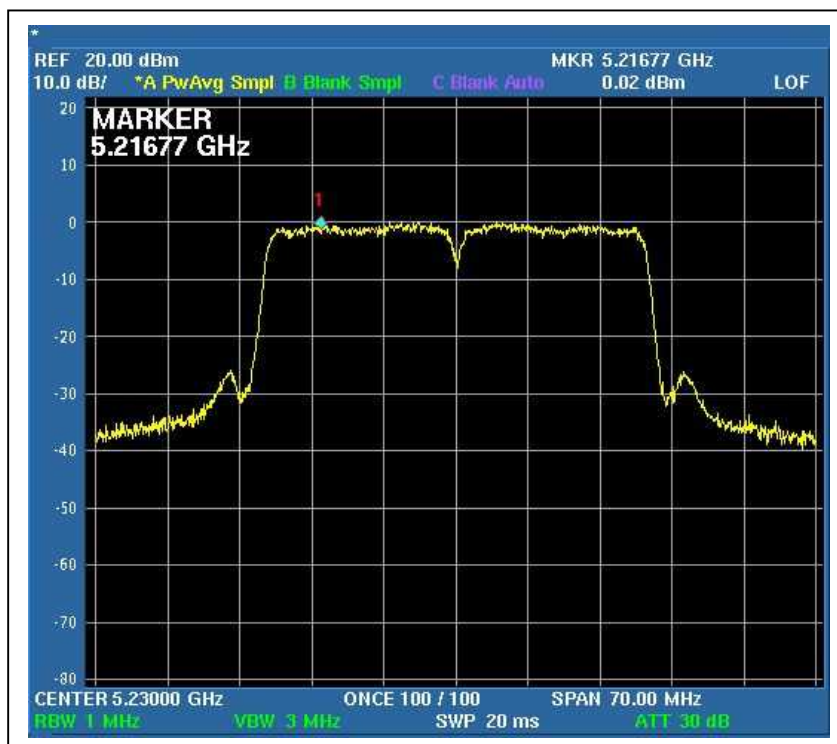



4.6 FREQUENCY STABILITY

4.6.1 LIMITS OF FREQUENCY STABILITY MEASUREMENT

The frequency tolerance of the carrier signal shall be maintained within +/- 0.02% of the operating frequency over a temperature variation of -30 degrees to 50 degrees C at normal supply voltage, and for a variation in the primary supply voltage from 85% to 115% of the rated supply voltage at a temperature of 20 degrees C.

4.6.2 TEST INSTRUMENTS

DESCRIPTION & MANUFACTURER	MODEL NO.	SERIAL NO.	CALIBRATED DATE	CALIBRATED UNTIL
R&S SPECTRUM ANALYZER	FSP40	100037	Aug. 09, 2008	Aug. 08, 2009

NOTE:

- 1.The measurement uncertainty is less than +/- 2.6dB, which is calculated as per the NAMAS document NIS81. This uncertainty represents an expanded uncertainty expressed at approximately the 95% confidence level using a coverage factor of k=2.
- 2.The calibration interval of the above test instruments is 12 months and the calibrations are traceable to NML/ROC and NIST/USA.

4.6.3 TEST PROCEDURE

1. The EUT was placed inside the environmental test chamber and powered by nominal DC voltage.
2. Turn the EUT on and couple its output to a spectrum analyzer.
3. Turn the EUT off and set the chamber to the highest temperature specified.
4. Allow sufficient time (approximately 30 min) for the temperature of the chamber to stabilize, turn the EUT on and measure the operating frequency after 2, 5, and 10 minutes.
5. Repeat step 2 and 3 with the temperature chamber set to the lowest temperature.
6. The test chamber was allowed to stabilize at +20 degree C for a minimum of 30 minutes. The supply voltage was then adjusted on the EUT from 85% to 115% and the frequency record.

4.6.4 DEVIATION FROM TEST STANDARD

No deviation

4.6.5 TEST SETUP

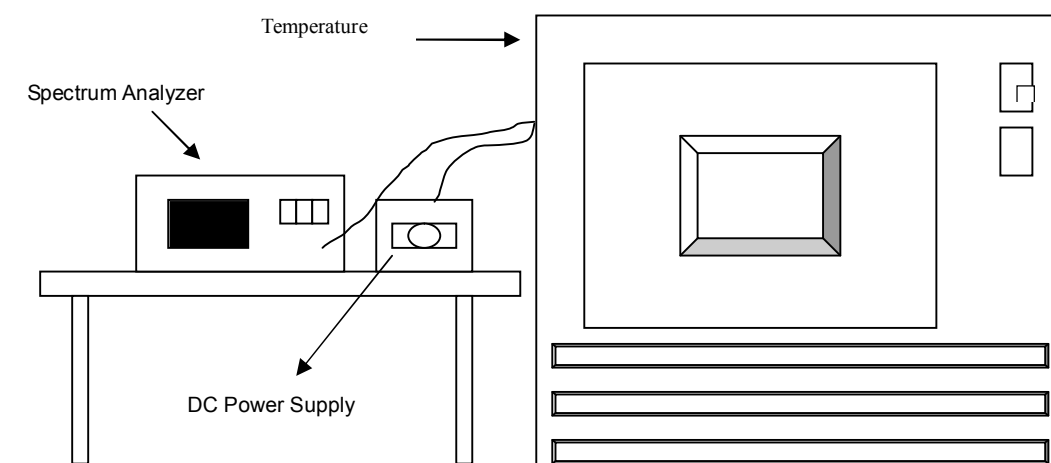

4.6.6 EUT OPERATING CONDITION

The software provided by client to enable the EUT under transmission condition continuously at specific channel frequencies individually.



4.6.7 TEST RESULTS

		Operating frequency: 5180MHz				Limit : ± 0.02%	
Temp. (°C)	Power supply (VAC)	2 minute		5 minute		10 minute	
		(MHz)	(%)	(MHz)	(%)	(MHz)	(%)
50	126.5	5180.0286	0.000552	5180.0264	0.000510	5180.0244	0.000471
	110	5180.0278	0.000537	5180.0287	0.000554	5180.0264	0.000510
	93.5	5180.0275	0.000531	5180.0254	0.000490	5180.0244	0.000471
40	126.5	5180.0338	0.000653	5180.0341	0.000658	5180.0347	0.000670
	110	5180.0334	0.000645	5180.0342	0.000660	5180.0342	0.000660
	93.5	5180.034	0.000656	5180.0338	0.000653	5180.0345	0.000666
30	126.5	5180.0091	0.000176	5180.0085	0.000164	5180.0082	0.000158
	110	5180.0093	0.000180	5180.0087	0.000168	5180.0085	0.000164
	93.5	5180.0095	0.000183	5180.0085	0.000164	5180.0084	0.000162
20	126.5	5179.9894	0.000205	5179.9894	0.000205	5179.9894	0.000205
	110	5179.9896	0.000201	5179.9896	0.000201	5179.9893	0.000207
	93.5	5179.9898	0.000197	5179.9897	0.000199	5179.9892	0.000208
10	126.5	5180.0275	0.000531	5180.0223	0.000431	5180.0182	0.000351
	110	5180.0277	0.000535	5180.0257	0.000496	5180.0214	0.000413
	93.5	5180.0271	0.000523	5180.0212	0.000409	5180.0195	0.000376
0	126.5	5180.0091	0.000176	5180.0092	0.000178	5180.0094	0.000181
	110	5180.0095	0.000183	5180.0093	0.000180	5180.0097	0.000187
	93.5	5180.0093	0.000180	5180.0096	0.000185	5180.0089	0.000172
-10	126.5	5180.0046	0.000089	5180.0043	0.000083	5180.0037	0.000071
	110	5180.0044	0.000085	5180.0045	0.000087	5180.0045	0.000087
	93.5	5180.0048	0.000093	5180.0047	0.000091	5180.0033	0.000064
-20	126.5	5180.0212	0.000409	5180.0152	0.000293	5180.0154	0.000297
	110	5180.0211	0.000407	5180.0184	0.000355	5180.0164	0.000317
	93.5	5180.0152	0.000293	5180.0155	0.000299	5180.0154	0.000297
-30	126.5	5179.9855	0.000280	5179.995	0.000097	5179.9947	0.000102
	110	5179.9856	0.000278	5179.995	0.000097	5179.9949	0.000098
	93.5	5179.9955	0.000087	5179.9953	0.000091	5179.9946	0.000104



4.7 ANTENNA PORT OUTPUT SPECTRUM PLOTS

4.7.1 TEST INSTRUMENTS

DESCRIPTION & MANUFACTURER	MODEL NO.	SERIAL NO.	CALIBRATED DATE	CALIBRATED UNTIL
R&S SPECTRUM ANALYZER	FSP40	100037	Aug. 09, 2008	Aug. 08, 2009

NOTE:

- 1.The measurement uncertainty is less than +/- 2.6dB, which is calculated as per the NAMAS document NIS81. This uncertainty represents an expanded uncertainty expressed at approximately the 95% confidence level using a coverage factor of k=2.
- 2.The calibration interval of the above test instruments is 12 months and the calibrations are traceable to NML/ROC and NIST/USA.

4.7.2 TEST PROCEDURE

The transmitter output was connected to the spectrum analyzer via a low loss cable. Set RBW of spectrum analyzer to 1MHz with suitable frequency span including 100 MHz bandwidth from band edge. The band edges was measured and recorded.

4.7.3 EUT OPERATING CONDITION

The software provided by client to enable the EUT under transmission condition continuously at specific channel frequencies individually.

4.7.4 TEST RESULTS

For 5.15 to 5.25GHz band:

The spectrum plots (Peak RBW=1MHz, VBW=3MHz) are attached on the following pages.

802.11a OFDM modulation

CH 1

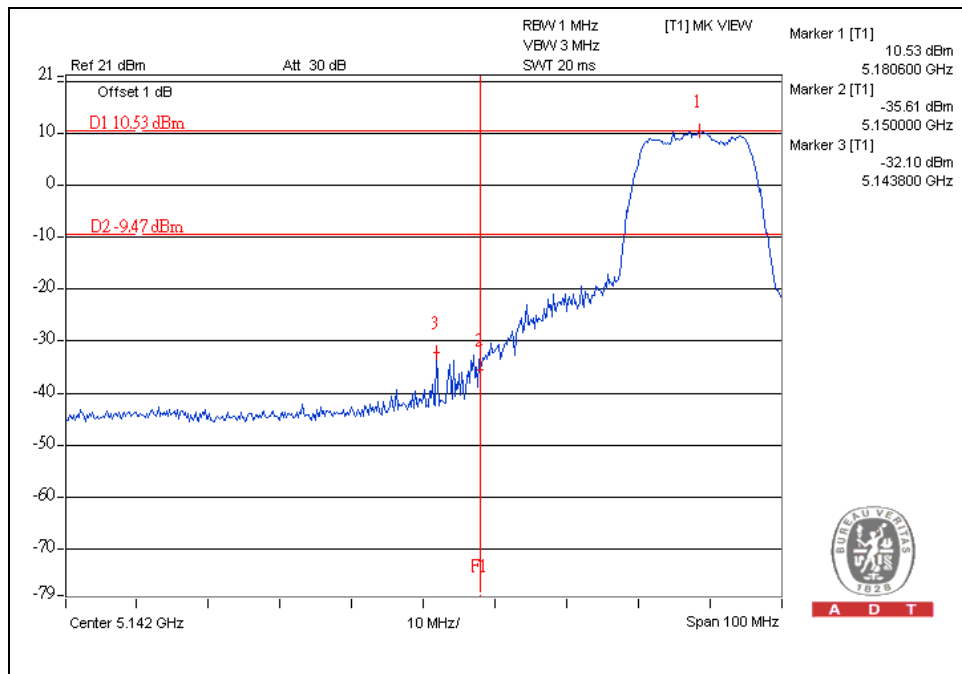

CH 4

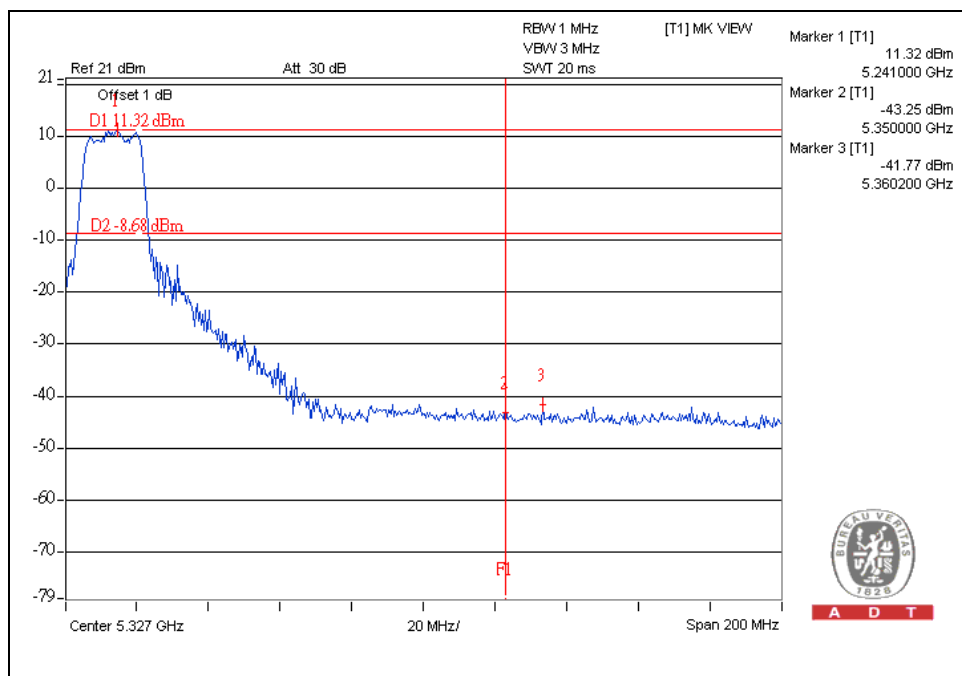



A D T

CH 1

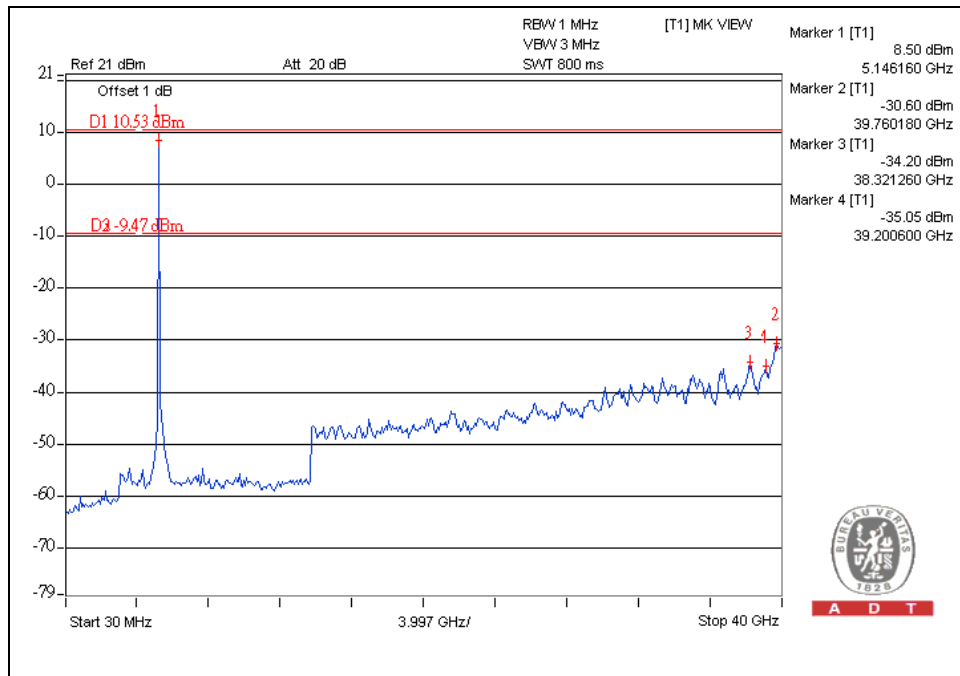

CH 4

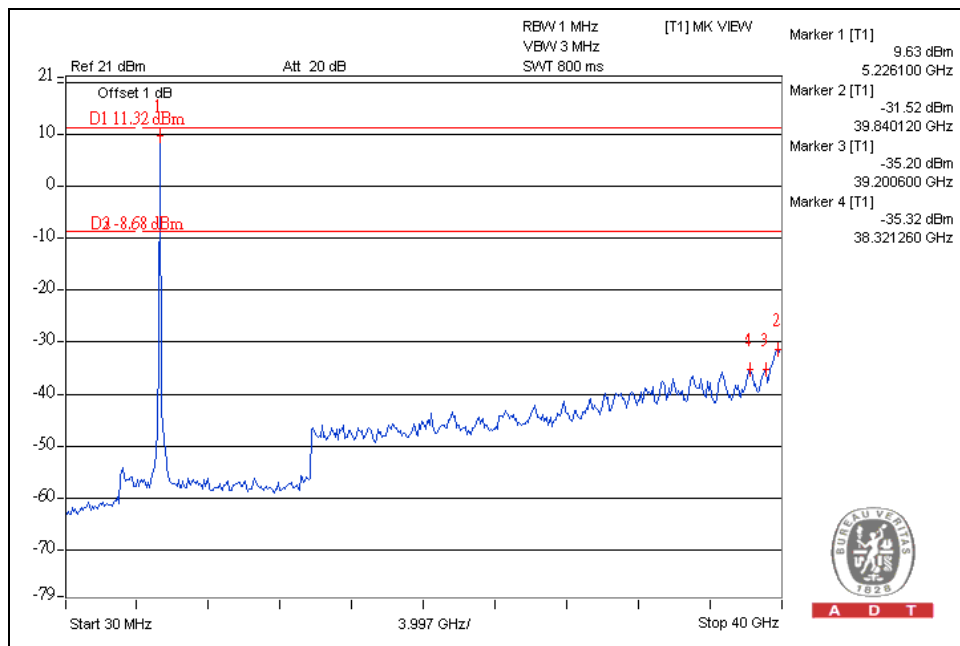

DRAFT 802.11n (20MHz) OFDM MODULATION:

For chain (0):

CH1

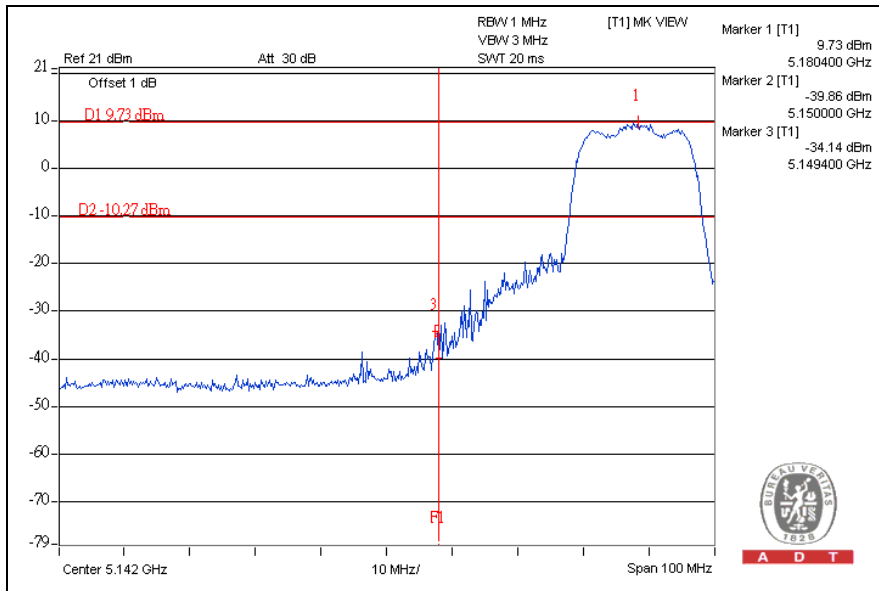

CH4

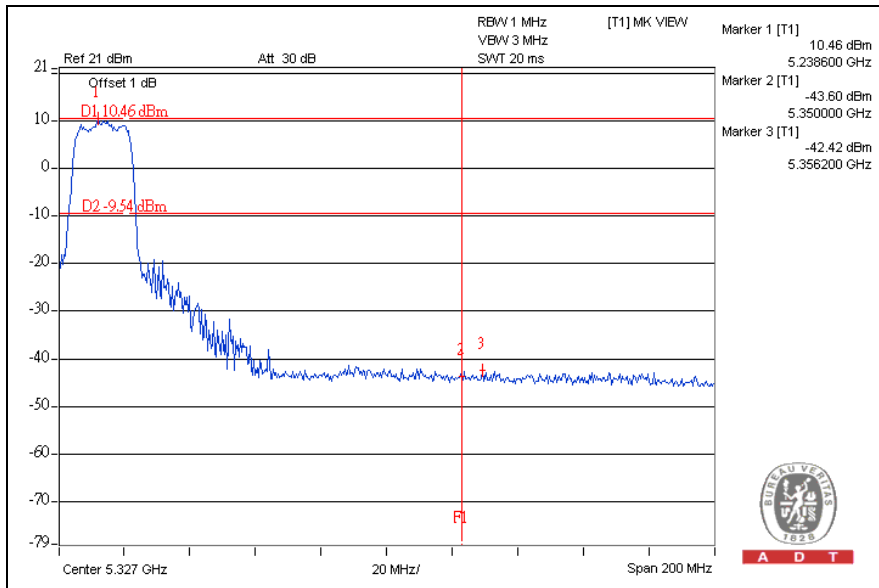

For chain (1):

CH1

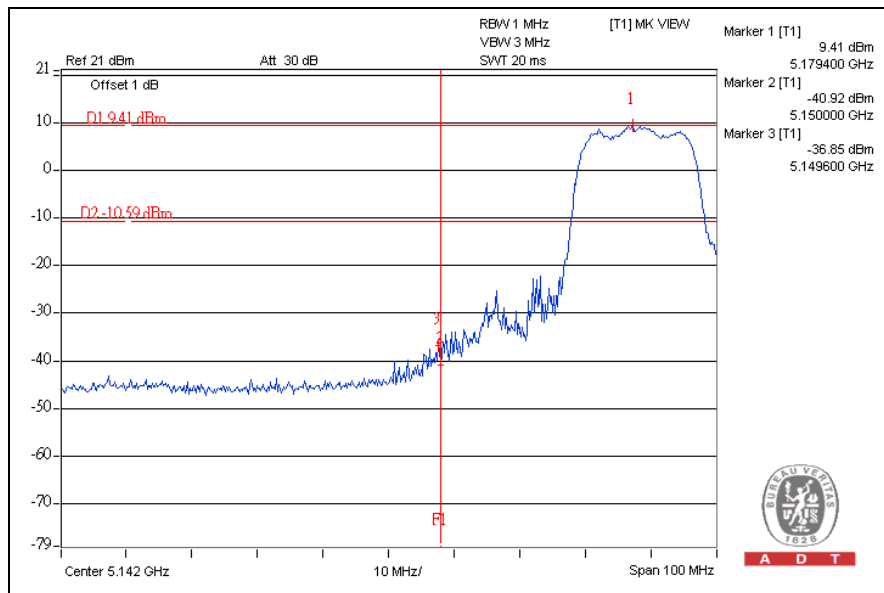

CH4

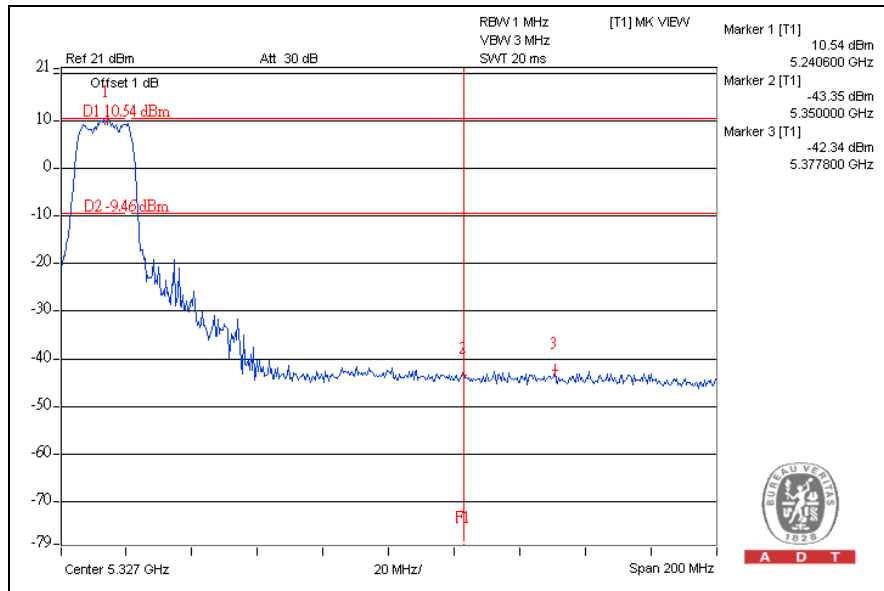



A D T

For chain (0):

CH1

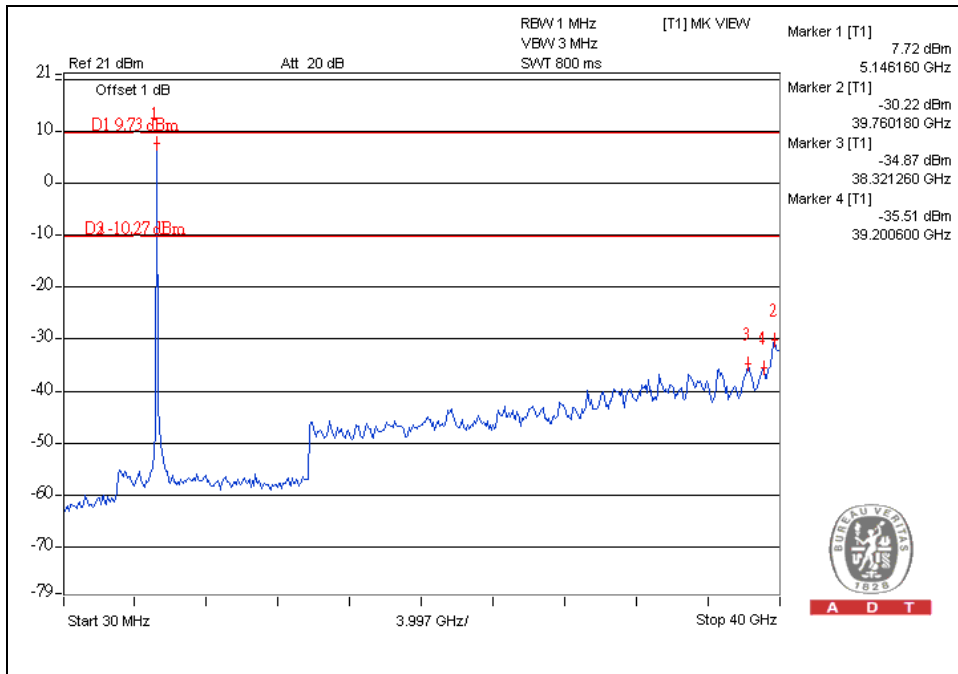

CH4

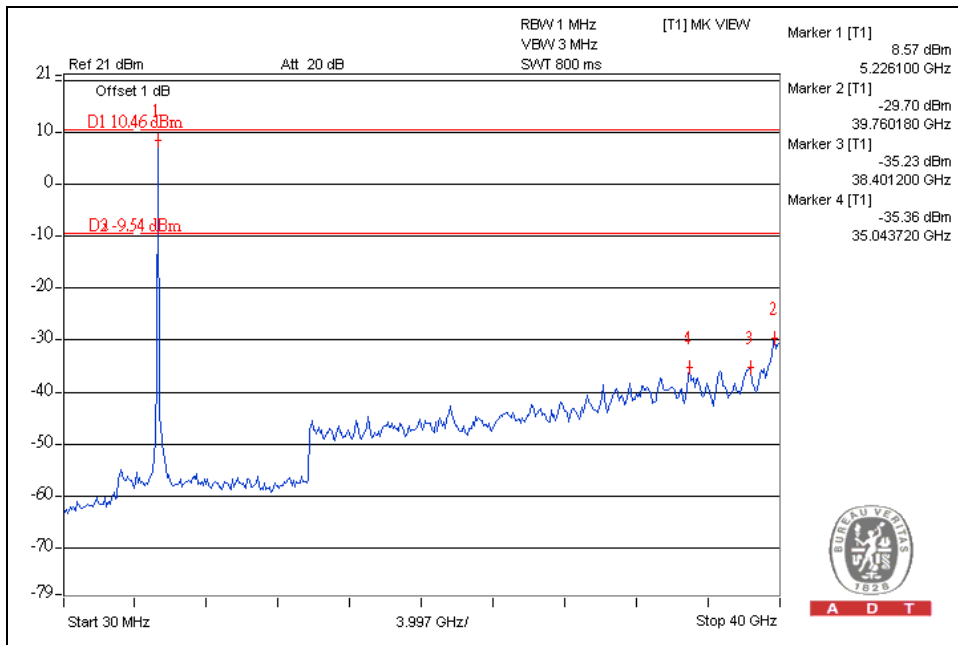

For chain (1):

CH1

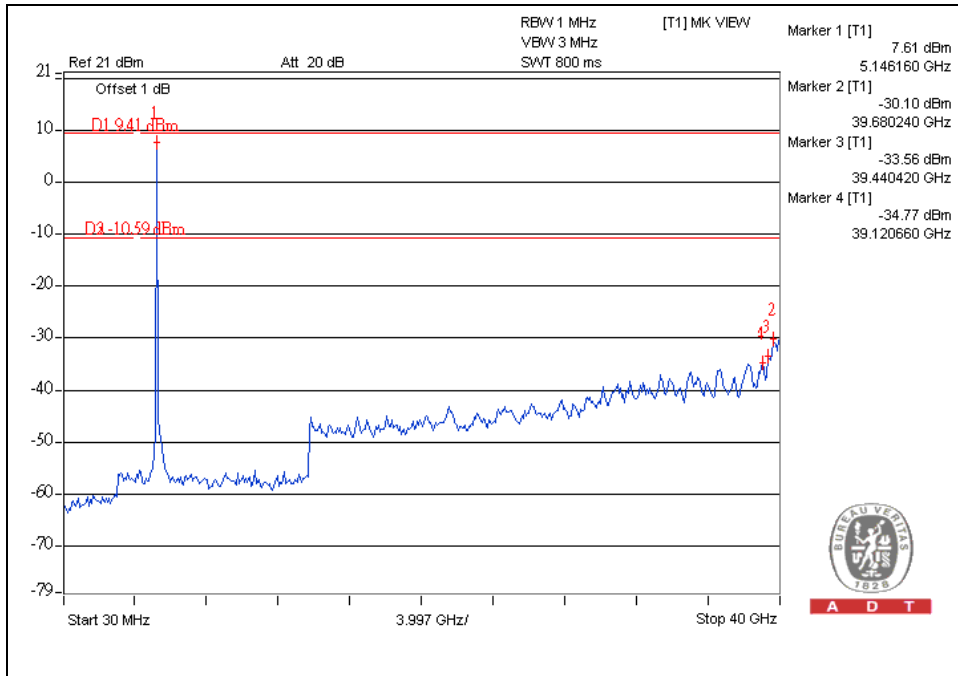

CH4

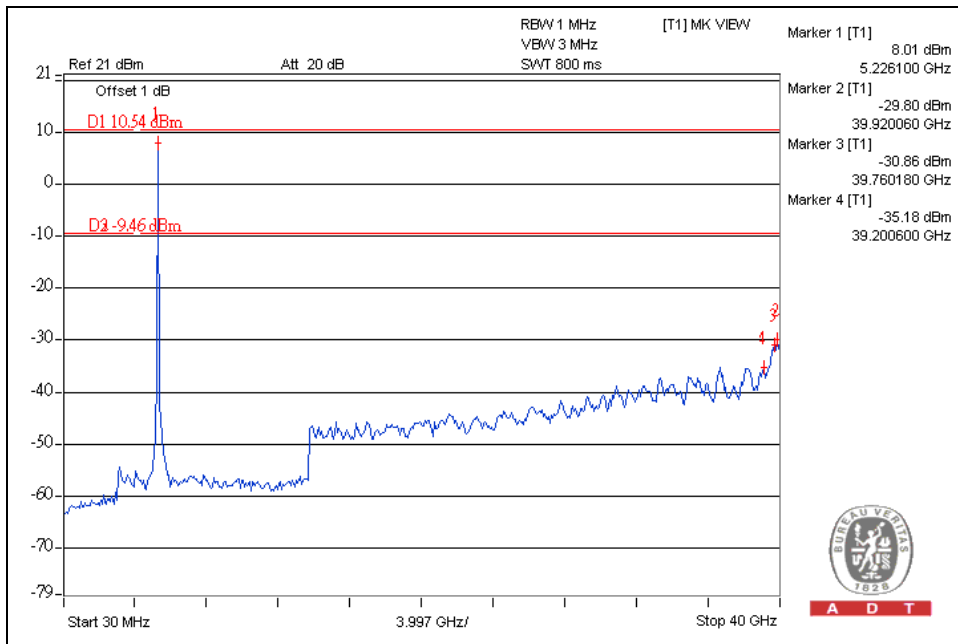

DRAFT 802.11n (40MHz) OFDM MODULATION:

For chain (0):

CH1

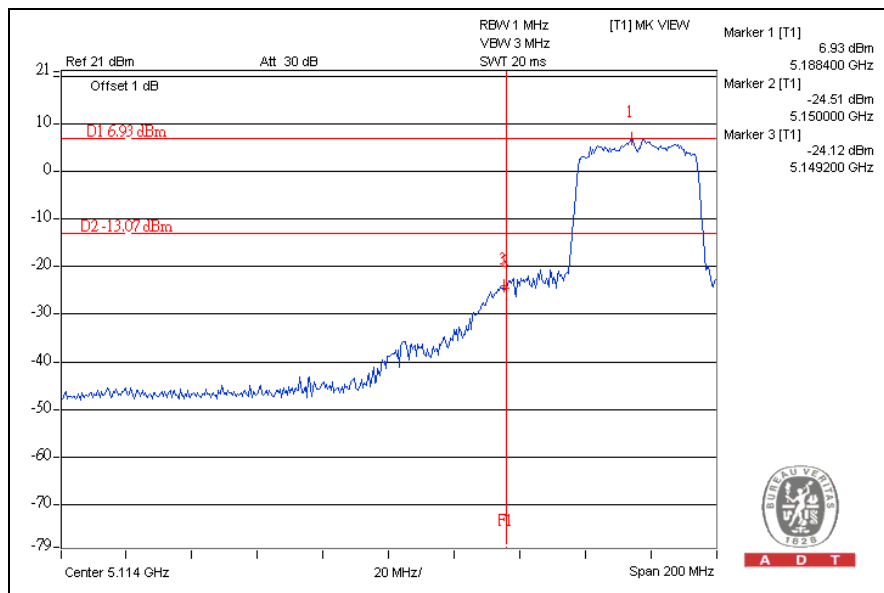

CH2

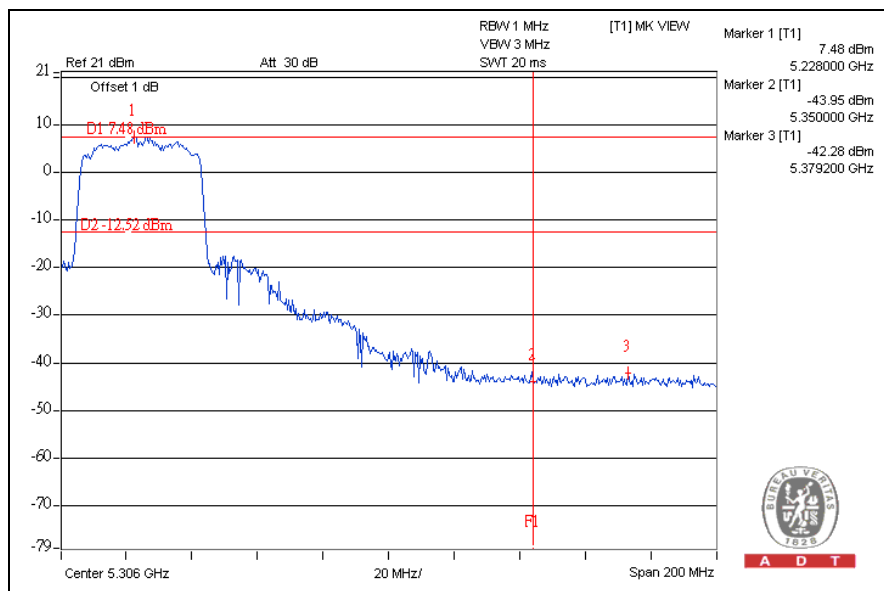

For chain (1):

CH1

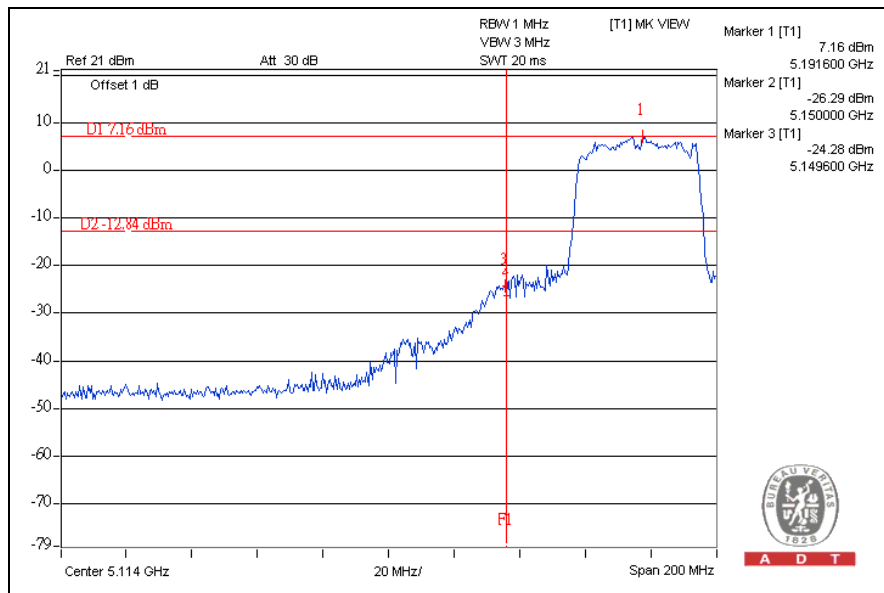

CH2

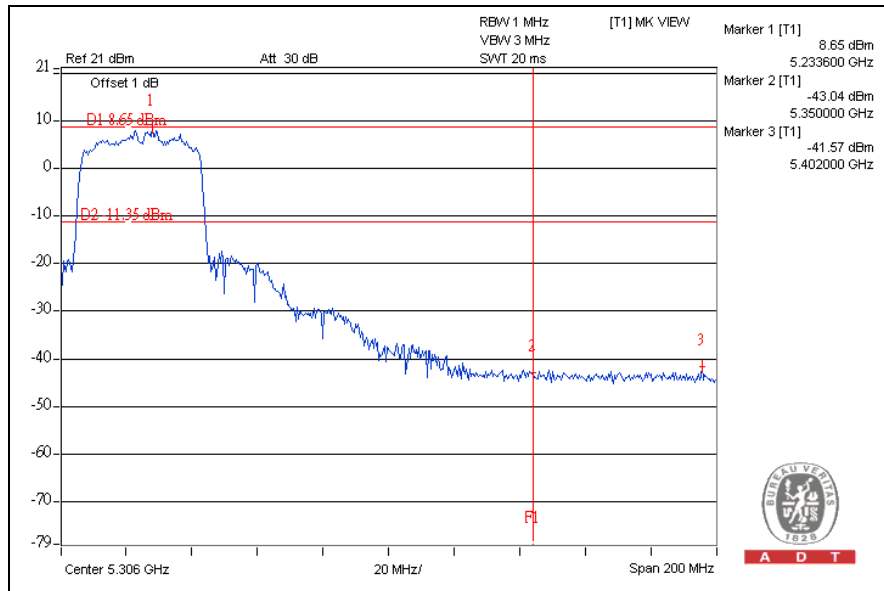



A D T

For chain (0):

CH1

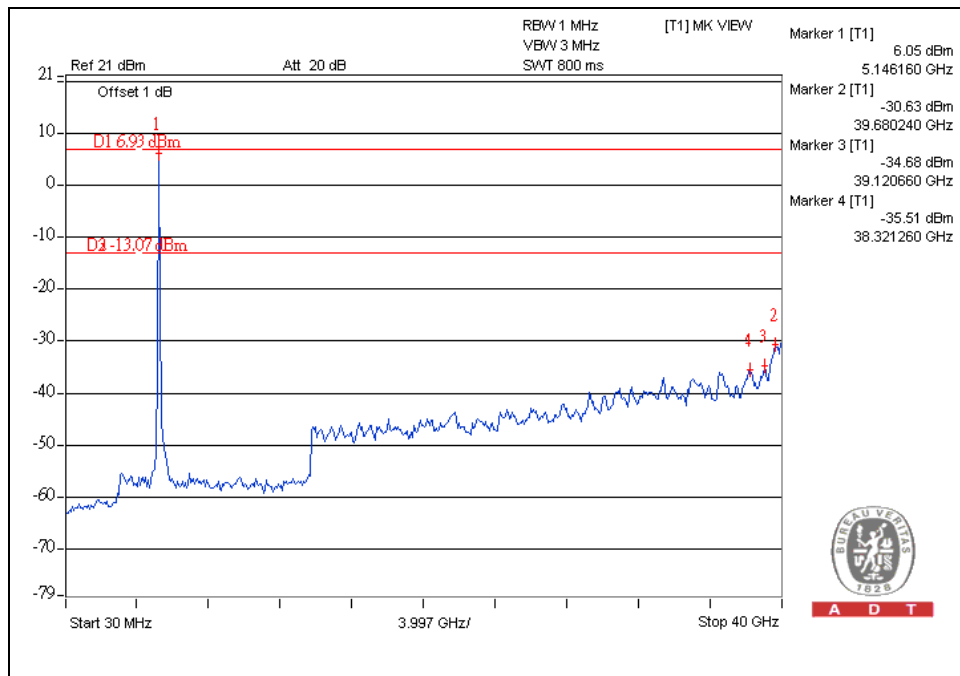

CH2

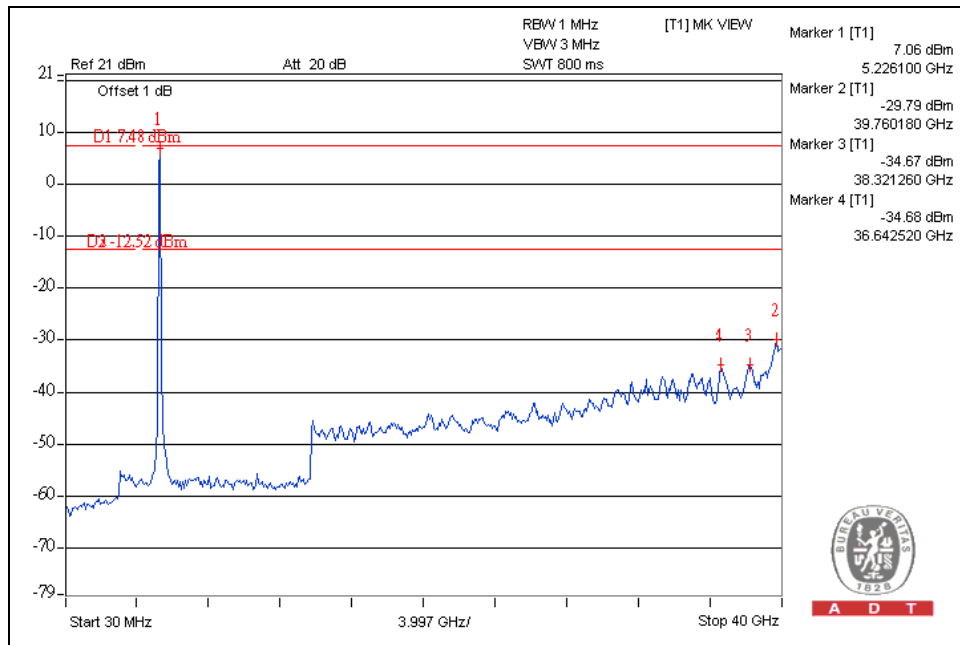

For chain (1):

CH1

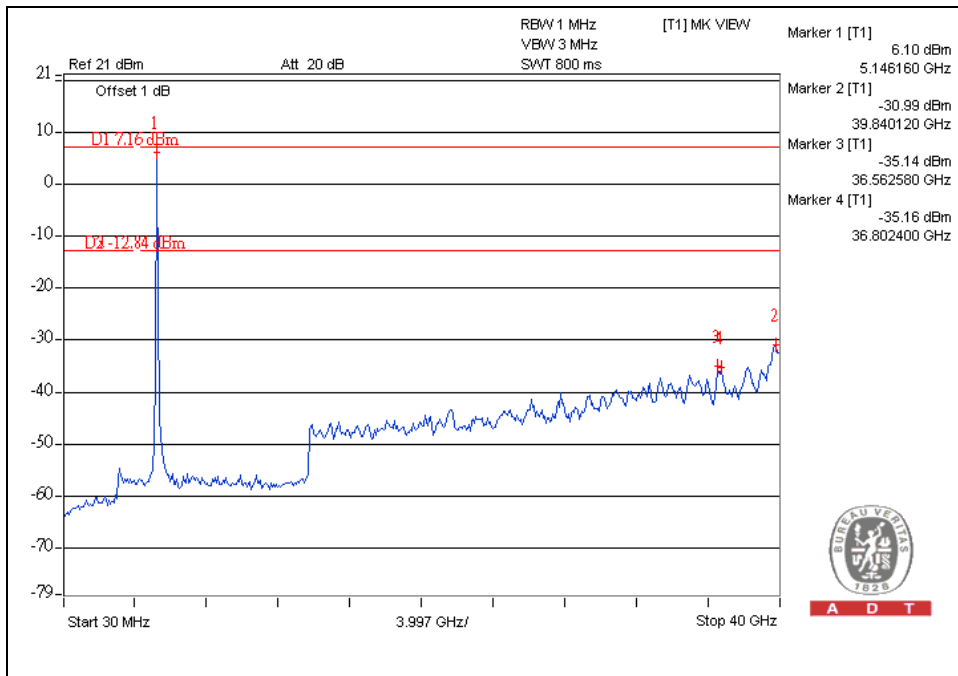

CH2

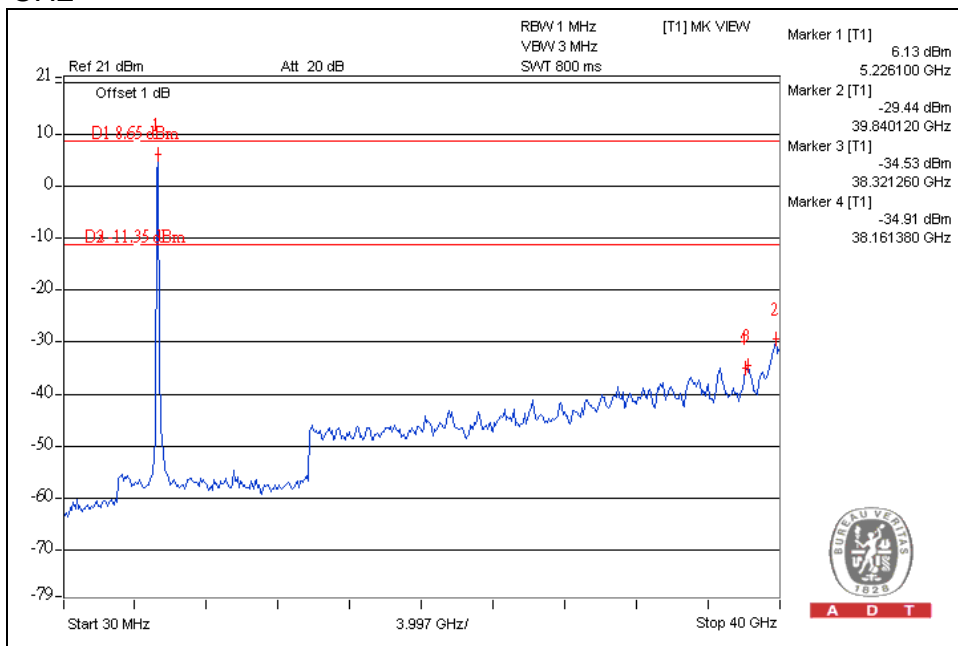



4.8 ANTENNA REQUIREMENT

4.8.1 STANDARD APPLICABLE

For intentional device, according to FCC 47 CFR Section 15.203, an intentional radiator shall be designed to ensure that no antenna other than that furnished by the responsible party shall be used with the device.

And according to FCC 47 CFR Section 15.407(a), if transmitting antennas of directional gain greater than 6dBi are used, the power shall be reduced by the amount in dB that the directional gain of the antenna exceeds 6dBi.

4.8.2 ANTENNA CONNECTED CONSTRUCTION

There are three antennas provided to this EUT, please refer to the following table:

Transmitter / Circuit	Antenna Gain			Antenna Type	Connector
	For 2.4GHz Gain (dBi)	For 5.15~ 5.25GHz Gain (dBi)	For 5.725~ 5.850GHz Gain (dBi)		
Chain(0)J9	2.0	4.3	5.6	PIFA	UFL
Chain(1)J14	4.5	5.6	4.9	PIFA	UFL
Chain(2)J10	4.2	4.4	4.5	PIFA	UFL



A D T

5. INFORMATION ON THE TESTING LABORATORIES

We, Bureau Veritas Consumer Products Services (H.K.) Ltd., Taoyuan Branch, were founded in 1988 to provide our best service in EMC, Radio, Telecom and Safety consultation. Our laboratories are accredited and approved by the following approval agencies according to ISO/IEC 17025:

USA	FCC, NVLAP
Germany	TUV Rheinland
Japan	VCCI
Norway	NEMKO
Canada	INDUSTRY CANADA, CSA
R.O.C.	TAF, BSMI, NCC
Netherlands	Telefication
Singapore	GOST-ASIA(MOU)
Russia	CERTIS(MOU)

Copies of accreditation certificates of our laboratories obtained from approval agencies can be downloaded from our web site:

www.adt.com.tw/index.5/phtml. If you have any comments, please feel free to contact us at the following:

Linko EMC/RF Lab:

Tel: 886-2-26052180

Fax: 886-2-26052943

Hsin Chu EMC/RF Lab:

Tel: 886-3-5935343

Fax: 886-3-5935342

Hwa Ya EMC/RF/Safety Telecom Lab:

Tel: 886-3-3183232

Fax: 886-3-3185050

Web Site: www.adt.com.tw

The address and road map of all our labs can be found in our web site also



A D T

6.APPENDIX A - MODIFICATIONS RECORDERS FOR ENGINEERING CHANGES TO THE EUT BY THE LAB

No any modifications are made to the EUT by the lab during the test.

--- END ---