



FCC TEST REPORT

REPORT NO.: RF991129E05

MODEL NO.: E1500

FCC ID: Q87-E1500

RECEIVED: Nov. 29, 2010

TESTED: Nov. 29 to Dec. 15, 2010

ISSUED: Dec. 28, 2010

APPLICANT: Cisco Consumer Products LLC

ADDRESS: 121 Theory Drive Irvine, CA 92617(USA)

ISSUED BY: Bureau Veritas Consumer Products Services (H.K.)
Ltd., Taoyuan Branch Hsin Chu Laboratory

LAB ADDRESS : No. 81-1, Lu Liao Keng, 9th Ling, Wu Lung Tsuen,
Chiung Lin Hsiang, Hsin Chu Hsien 307, Taiwan

TEST LOCATION (1): No. 81-1, Lu Liao Keng, 9th Ling, Wu Lung Tsuen,
Chiung Lin Hsiang, Hsin Chu Hsien 307, Taiwan

TEST LOCATION (2): No. 49, Ln. 206, Wende Rd., Shangshan Tsuen,
Chiung Lin Hsiang, Hsin Chu Hsien 307, Taiwan

This test report consists of 83 pages in total. It may be duplicated completely for legal use with the approval of the applicant. It should not be reproduced except in full, without the written approval of our laboratory. The client should not use it to claim product certification, approval, or endorsement by TAF or any government agencies. The test results in the report only apply to the tested sample.





Table of Contents

RELEASE CONTROL RECORD	4
1. CERTIFICATION	5
2. SUMMARY OF TEST RESULTS	6
2.1 MEASUREMENT UNCERTAINTY	7
3. GENERAL INFORMATION.....	8
3.1 GENERAL DESCRIPTION OF EUT	8
3.2 DESCRIPTION OF TEST MODES	10
3.2.1 TEST MODE APPLICABILITY AND TESTED CHANNEL DETAIL	11
3.3 GENERAL DESCRIPTION OF APPLIED STANDARDS	14
3.4 DESCRIPTION OF SUPPORT UNITS.....	15
3.5 CONFIGURATION OF SYSTEM UNDER TEST.....	16
4. TEST TYPES AND RESULTS	18
4.1 CONDUCTED EMISSION MEASUREMENT.....	18
4.1.1 LIMITS OF CONDUCTED EMISSION MEASUREMENT	18
4.1.2 TEST INSTRUMENTS	18
4.1.3 TEST PROCEDURES.....	19
4.1.4 DEVIATION FROM TEST STANDARD	19
4.1.5 TEST SETUP	20
4.1.6 EUT OPERATING CONDITIONS	20
4.1.7 TEST RESULTS-MODE 1	21
4.1.8 TEST RESULTS-MODE 2.....	23
4.2 RADIATED EMISSION MEASUREMENT	25
4.2.1 LIMITS OF RADIATED EMISSION MEASUREMENT	25
4.2.2 TEST INSTRUMENTS	26
4.2.3 TEST PROCEDURES.....	28
4.2.4 DEVIATION FROM TEST STANDARD	28
4.2.5 TEST SETUP	29
4.2.6 EUT OPERATING CONDITIONS	30
4.2.7 TEST RESULTS	31
4.3 6dB BANDWIDTH MEASUREMENT	60
4.3.1 LIMITS OF 6dB BANDWIDTH MEASUREMENT.....	60
4.3.2 TEST INSTRUMENTS	60
4.3.3 TEST PROCEDURE.....	60
4.3.4 DEVIATION FROM TEST STANDARD	60
4.3.5 TEST SETUP	60
4.3.6 EUT OPERATING CONDITIONS	60
4.3.7 TEST RESULTS	61
4.4 MAXIMUM PEAK OUTPUT POWER.....	65
4.4.1 LIMITS OF MAXIMUM PEAK OUTPUT POWER MEASUREMENT	65
4.4.2 INSTRUMENTS.....	65



A D T

4.4.3	TEST PROCEDURES.....	65
4.4.4	DEVIATION FROM TEST STANDARD	65
4.4.5	TEST SETUP	65
4.4.6	EUT OPERATING CONDITIONS	65
4.4.7	TEST RESULTS	66
4.5	POWER SPECTRAL DENSITY MEASUREMENT.....	68
4.5.1	LIMITS OF POWER SPECTRAL DENSITY MEASUREMENT	68
4.5.2	TEST INSTRUMENTS	68
4.5.3	TEST PROCEDURE.....	68
4.5.4	DEVIATION FROM TEST STANDARD	68
4.5.5	TEST SETUP	68
4.5.6	EUT OPERATING CONDITION.....	68
4.5.7	TEST RESULTS	69
4.6	CONDUCTED OUT-BAND EMISSION MEASUREMENT	73
4.6.1	LIMITS OF CONDUCTED OUT-BAND EMISSION MEASUREMENT.....	73
4.6.2	TEST INSTRUMENTS	73
4.6.3	TEST PROCEDURE.....	73
4.6.4	DEVIATION FROM TEST STANDARD	73
4.6.5	EUT OPERATING CONDITION.....	73
4.6.6	TEST RESULTS	73
5.	INFORMATION ON THE TESTING LABORATORIES	82
6.	APPENDIX A - MODIFICATIONS RECORDERS FOR ENGINEERING CHANGES TO THE EUT BY THE LAB	83



RELEASE CONTROL RECORD

ISSUE NO.	REASON FOR CHANGE	DATE ISSUED
Original release	NA	Dec. 28, 2010



A D T

1. CERTIFICATION

PRODUCT: Wireless-N Router
BRAND NAME: Cisco
MODEL NO.: E1500
TEST SAMPLE: ENGINEERING SAMPLE
TESTED: Nov. 29 to Dec. 15, 2010
APPLICANT: Cisco Consumer Products LLC
STANDARDS: FCC Part 15, Subpart C (Section 15.247)
ANSI C63.4-2003
ANSI C63.10-2009

The above equipment (Model: E1500) has been tested by **Bureau Veritas Consumer Products Services (H.K.) Ltd., Taoyuan Branch**, and found compliance with the requirement of the above standards. The test record, data evaluation & Equipment Under Test (EUT) configurations represented herein are true and accurate accounts of the measurements of the sample's EMC characteristics under the conditions specified in this report.

PREPARED BY : Carol Liao , **DATE:** Dec. 28, 2010
(Carol Liao, Specialist)

APPROVED BY : May Chen , **DATE:** Dec. 28, 2010
(May Chen, Deputy Manager)



A D T

2. SUMMARY OF TEST RESULTS

The EUT has been tested according to the following specifications:

APPLIED STANDARD: FCC Part 15, Subpart C			
Standard Section	Test Type and Limit	Result	Remark
15.207	AC Power Conducted Emission	PASS	Meet the requirement of limit. Minimum passing margin is -11.12dB at 4.334MHz
15.247(a)(2)	Spectrum Bandwidth of a Direct Sequence Spread Spectrum System Limit: min. 500kHz	PASS	Meet the requirement of limit.
15.247(b)	Maximum Peak Output Power Limit: max. 30dBm	PASS	Meet the requirement of limit.
15.247(d)	Radiated Emissions Limit: Table 15.209	PASS	Meet the requirement of limit. Minimum passing margin is -0.5dB at 7311.00MHz
15.247(e)	Power Spectral Density Limit: max. 8dBm	PASS	Meet the requirement of limit.
15.247(d)	Conducted Out-Band Emission Measurement Limit: 20dB less than the peak value of fundamental frequency	PASS	Meet the requirement of limit.
15.203	Antenna Requirement	PASS	No antenna connector is used.

2.1 MEASUREMENT UNCERTAINTY

Where relevant, the following measurement uncertainty levels have been estimated for tests performed on the EUT as specified in CISPR 16-4-2:

This uncertainty represents an expanded uncertainty expressed at approximately the 95% confidence level using a coverage factor of $k=2$.

Measurement	Value
Conducted emissions	2.45 dB
Radiated emissions (30MHz-1GHz)	3.76 dB
Radiated emissions (1GHz -18GHz)	2.49 dB
Radiated emissions (18GHz -40GHz)	2.70 dB



A D T

3. GENERAL INFORMATION

3.1 GENERAL DESCRIPTION OF EUT

PRODUCT	Wireless-N Router
MODEL NO.	E1500
FCC ID	Q87-E1500
POWER SUPPLY	DC 12V from power adapter
MODULATION TYPE	CCK, DQPSK, DBPSK for DSSS 64QAM, 16QAM, QPSK, BPSK for OFDM
MODULATION TECHNOLOGY	DSSS, OFDM
TRANSFER RATE	802.11b: 11 / 5.5 / 2 / 1Mbps 802.11g: 54 / 48 / 36 / 24 / 18 / 12 / 9 / 6Mbps 802.11n (20MHz, 800ns GI): 130 / 117 / 104 / 78 / 52 / 39 / 26 / 13 / 65 / 58.5 / 52 / 39 / 26 / 19.5 / 13 / 6.5Mbps 802.11n (40MHz, 800ns GI): 270 / 243 / 216 / 162 / 108 / 81 / 54 / 27 / 135 / 121.5 / 108 / 81 / 54 / 40.5 / 27 / 13.5Mbps
FREQUENCY RANGE	2412MHz ~ 2462MHz
NUMBER OF CHANNEL	11 for 802.11b, 802.11g, 802.11n (20MHz) 7 for 802.11n (40MHz)
MAXIMUM OUTPUT POWER	802.11b: 162.2mW 802.11g: 371.5mW 802.11n (20MHz): 618.2mW 802.11n (40MHz): 449.6mW
ANTENNA TYPE	Please see note 1
DATA CABLE	NA
I/O PORTS	RJ-45 port x 4(Ethernet: 10, 100Mbps) RJ-45 port x 1(Internet: 10, 100Mbps)
ASSOCIATED DEVICES	Adapter x 1

NOTE:

1. There are three antennas provided to this EUT, please refer to the following table:

No.	Transmitter Circuit	Antenna Type	Antenna Connector	Antenna Gain (dBi)	Frequency range (MHz)
1	Chain(0)	Dipole	NA	4.5	2400~2483.5
2	Chain(1)	Dipole	NA	4	2400~2483.5
3	Chain(2)	Dipole	NA	3	2400~2483.5

2. The EUT must be supplied with a power adapter and following two different model names could be chosen:

Adapter	Brand	Model No.	Spec.
Adapter 1	Bestec	EA0061WAA	AC Input: 100-240V, 50/60Hz, 0.5A DC Output: 12V, 0.5A DC output cable(Unshielded, 1.5m)
Adapter 2	Leader	MU08-6120050-A1	AC Input: 100-240V, 50/60Hz, 0.3A DC Output: 12V, 0.5A DC output cable(Unshielded, 1.5m)

For radiated test, the EUT was pre-tested with above adapters, the worse case was found in adapter 1. Therefore only the test data of the adapter was recorded in this report.

3. The device designs for lay on the table application.
4. The EUT incorporates a MIMO function with 802.11n.
5. The EUT is 2 * 2 spatial MIMO (2Tx & 2Rx) without beam forming function. The 11b/g legacy mode is limited to single transmitter only.
6. The EUT complies with 802.11n standards and backwards compatible with 802.11b, 802.11g products.
7. When the EUT operating in 802.11n, the software operation, which is defined by manufacturer, MCS (Modulation and Coding Schemes) from 0 to 15.
8. The above EUT information was declared by manufacturer and for more detailed features description, please refer to the manufacturer's specifications or user's manual.



3.2 DESCRIPTION OF TEST MODES

Eleven channels are provided for 802.11b, 802.11g, 802.11n (20MHz):

CHANNEL	FREQUENCY	CHANNEL	FREQUENCY
1	2412MHz	7	2442MHz
2	2417MHz	8	2447MHz
3	2422MHz	9	2452MHz
4	2427MHz	10	2457MHz
5	2432MHz	11	2462MHz
6	2437MHz		

Seven channels are provided for 802.11n (40MHz):

CHANNEL	FREQUENCY	CHANNEL	FREQUENCY
1	2422MHz	5	2442MHz
2	2427MHz	6	2447MHz
3	2432MHz	7	2452MHz
4	2437MHz		



3.2.1 TEST MODE APPLICABILITY AND TESTED CHANNEL DETAIL

EUT CONFIGURE MODE	APPLICABLE TO				DESCRIPTION
	PLC	RE < 1G	RE ≥ 1G	APCM	
MODE 1	√	√	√	√	With adapter 1
MODE 2	√	-	-	-	With adapter 2

Where **PLC**: Power Line Conducted Emission **RE < 1G**: Radiated Emission below 1GHz
RE ≥ 1G: Radiated Emission above 1GHz **APCM**: Antenna Port Conducted Measurement

ANTENNA COMBINATION MODE:

COMBINATION MODE	OPERATION MODE	TX CHAIN(0)	TX CHAIN(1)	TX CHAIN(2)
A	802.11 b	√		
B	802.11 b		√	
C	802.11 b			√
D	802.11 g	√		
E	802.11 g		√	
F	802.11 g			√
G	802.11n (20MHz) for MCS 0~15	√	√	
H	802.11n (20MHz) for MCS 0~15		√	√
I	802.11n (20MHz) for MCS 0~15	√		√
J	802.11n (40MHz) for MCS 0~15	√	√	
K	802.11n (40MHz) for MCS 0~15		√	√
L	802.11n (40MHz) for MCS 0~15	√		√

Note:

- The above information was declared by manufacturer and for more detailed features description, please refer to the manufacturer's specifications or user's manual.
- Mode A, D, G & J the worst modes were selected as representative mode for the report.

POWER LINE CONDUCTED EMISSION TEST:

- Pre-Scan has been conducted to determine the worst-case mode from all possible combinations between available modulations, data rates and antenna ports (if EUT with antenna diversity architecture).
- Following channel(s) was (were) selected for the final test as listed below.

MODE	AVAILABLE CHANNEL	TESTED CHANNEL	MODULATION TECHNOLOGY	MODULATION TYPE	DATA RATE (Mbps)	TX COMBINATION
802.11n (20MHz)	1 to 11	6	OFDM	BPSK	6.5	G



A D T

RADIATED EMISSION TEST (BELOW 1 GHz):

- Pre-Scan has been conducted to determine the worst-case mode from all possible combinations between available modulations, data rates and antenna ports (if EUT with antenna diversity architecture).
- Following channel(s) was (were) selected for the final test as listed below.

MODE	AVAILABLE CHANNEL	TESTED CHANNEL	MODULATION TECHNOLOGY	MODULATION TYPE	DATA RATE (Mbps)	TX COMBINATION
802.11n (20MHz)	1 to 11	6	OFDM	BPSK	6.5	G

RADIATED EMISSION TEST (ABOVE 1 GHz):

- Pre-Scan has been conducted to determine the worst-case mode from all possible combinations between available modulations, data rates and antenna ports (if EUT with antenna diversity architecture).
- Following channel(s) was (were) selected for the final test as listed below.

MODE	AVAILABLE CHANNEL	TESTED CHANNEL	MODULATION TECHNOLOGY	MODULATION TYPE	DATA RATE (Mbps)	TX COMBINATION
802.11b	1 to 11	1, 6, 11	DSSS	DBPSK	1	A
802.11g	1 to 11	1, 6, 11	OFDM	BPSK	6	D
802.11n (20MHz)	1 to 11	1, 6, 11	OFDM	BPSK	6.5	G
802.11n (40MHz)	1 to 7	1, 4, 7	OFDM	BPSK	13.5	J

CONDUCTED OUT-BAND EMISSION MEASUREMENT:

- Pre-Scan has been conducted to determine the worst-case mode from all possible combinations between available modulations, data rates and antenna ports (if EUT with antenna diversity architecture).
- Following channel(s) was (were) selected for the final test as listed below.

MODE	AVAILABLE CHANNEL	TESTED CHANNEL	MODULATION TECHNOLOGY	MODULATION TYPE	DATA RATE (Mbps)	TX COMBINATION
802.11b	1 to 11	1, 11	DSSS	DBPSK	1	A
802.11g	1 to 11	1, 11	OFDM	BPSK	6	D
802.11n (20MHz)	1 to 11	1, 11	OFDM	BPSK	6.5	G
802.11n (40MHz)	1 to 7	1, 7	OFDM	BPSK	13.5	J

※ After verification, conducted out band emission as show worst chain in report by investigations.



A D T

ANTENNA PORT CONDUCTED MEASUREMENT:

- This item includes all test value of each mode, but only includes spectrum plot of worst value of each mode.
- Pre-Scan has been conducted to determine the worst-case mode from all possible combinations between available modulations, data rates and antenna ports (if EUT with antenna diversity architecture).
- Following channel(s) was (were) selected for the final test as listed below.

MODE	AVAILABLE CHANNEL	TESTED CHANNEL	MODULATION TECHNOLOGY	MODULATION TYPE	DATA RATE (Mbps)	TX COMBINATION
802.11b	1 to 11	1, 6, 11	DSSS	DBPSK	1	A
802.11g	1 to 11	1, 6, 11	OFDM	BPSK	6	D
802.11n (20MHz)	1 to 11	1, 6, 11	OFDM	BPSK	6.5	G
802.11n (40MHz)	1 to 7	1, 4, 7	OFDM	BPSK	13.5	J

※ After verification, bandwidth as show worst chain in report by investigations.

※ TEST CONDITION:

APPLICABLE TO	ENVIRONMENTAL CONDITIONS	INPUT POWER	TESTED BY
RE ³ 1G	25deg. C, 67%RH, 1013 hPa	120Vac, 60Hz	Frank Liu
RE<1G	27deg. C, 72%RH, 1013 hPa	120Vac, 60Hz	Eric Lee
PLC	25deg. C, 60%RH, 1013 hPa	120Vac, 60Hz	Max Tseng
APCM	25deg. C, 60%RH, 1013 hPa	120Vac, 60Hz	Wen Yu



3.3 GENERAL DESCRIPTION OF APPLIED STANDARDS

The EUT is a RF product. According to the specifications of the manufacturer, it must comply with the requirements of the following standards:

FCC Part 15, Subpart C. (15.247)

ANSI C63.4-2003

ANSI C63.10-2009

All test items have been performed and recorded as per the above standards.

NOTE: The EUT has been verified to comply with the requirements of FCC Part 15, Subpart B, Class B (DoC). The test report has been issued separately.



3.4 DESCRIPTION OF SUPPORT UNITS

The EUT has been tested as an independent unit together with other necessary accessories or support units. The following support units or accessories were used to form a representative test configuration during the tests.

For conducted test					
NO.	PRODUCT	BRAND	MODEL NO.	SERIAL NO.	FCC ID
1	NOTEBOOK COMPUTER	DELL	D531	CN-0XM006-48643-86L-4472	QDS-BRCM1019
2	NOTEBOOK COMPUTER	DELL	PP17L	CN-ONF743-48643-7AV-0124	FCC DoC
3	NOTEBOOK COMPUTER	DELL	PP21L	CN-0GD366-70166-5B3-09ZX	QDS-BRCM1016
4	HUB	ZyXEL	ES-116P	S060H02000215	FCC DoC
For other test items					
NO.	PRODUCT	BRAND	MODEL NO.	SERIAL NO.	FCC ID
1	NOTEBOOK COMPUTER	DELL	D531	CN-0XM006-48643-86L-4472	QDS-BRCM1019
2	NOTEBOOK COMPUTER	DELL	PP17L	CN-ONF743-48643-7AV-0124	FCC DoC
3	HUB	ZyXEL	ES-116P	S060H02000215	FCC DoC

For conducted test	
NO.	SIGNAL CABLE DESCRIPTION OF THE ABOVE SUPPORT UNITS
1	10m UTP cable
2	10m UTP cable
3	NA
4	10m UTP cable
For other test items	
NO.	SIGNAL CABLE DESCRIPTION OF THE ABOVE SUPPORT UNITS
1	10m UTP cable
2	10m UTP cable
3	10m UTP cable

NOTE: 1. All power cords of the above support units are non shielded (1.8m).

3.5 CONFIGURATION OF SYSTEM UNDER TEST

For conducted test:

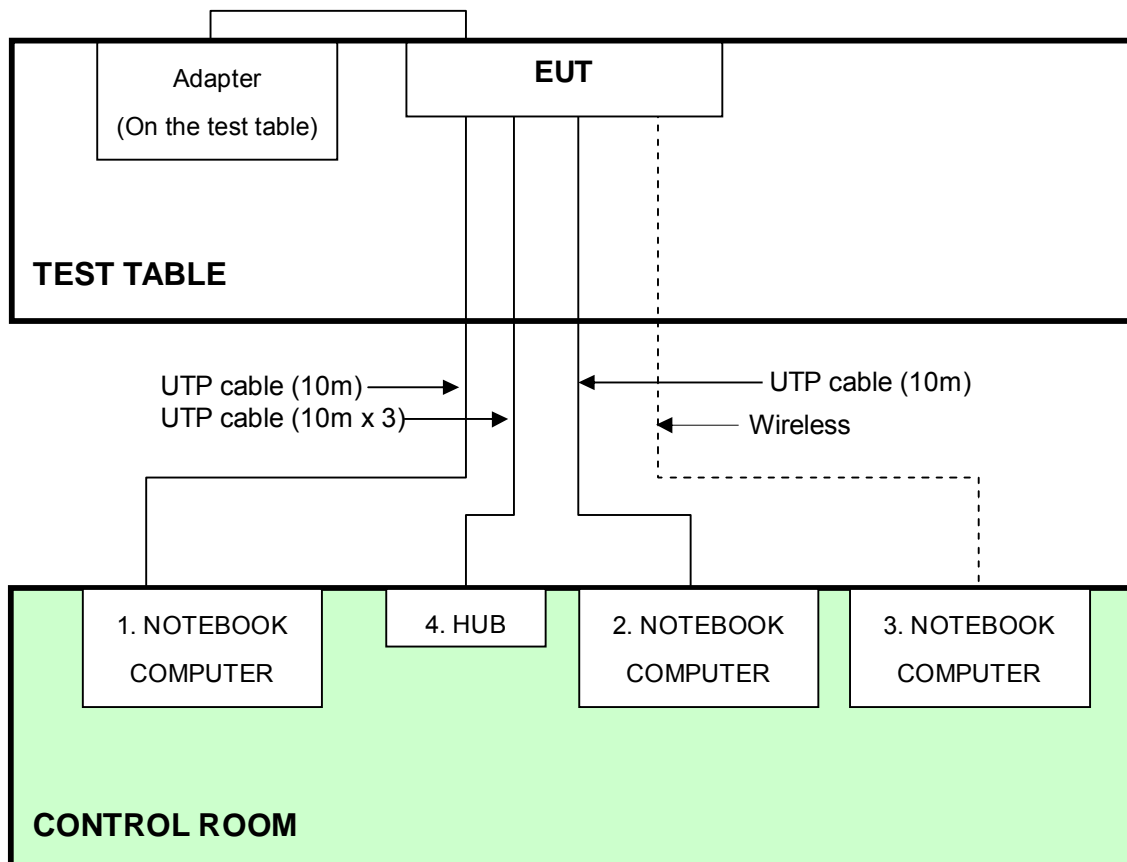

For other test items:

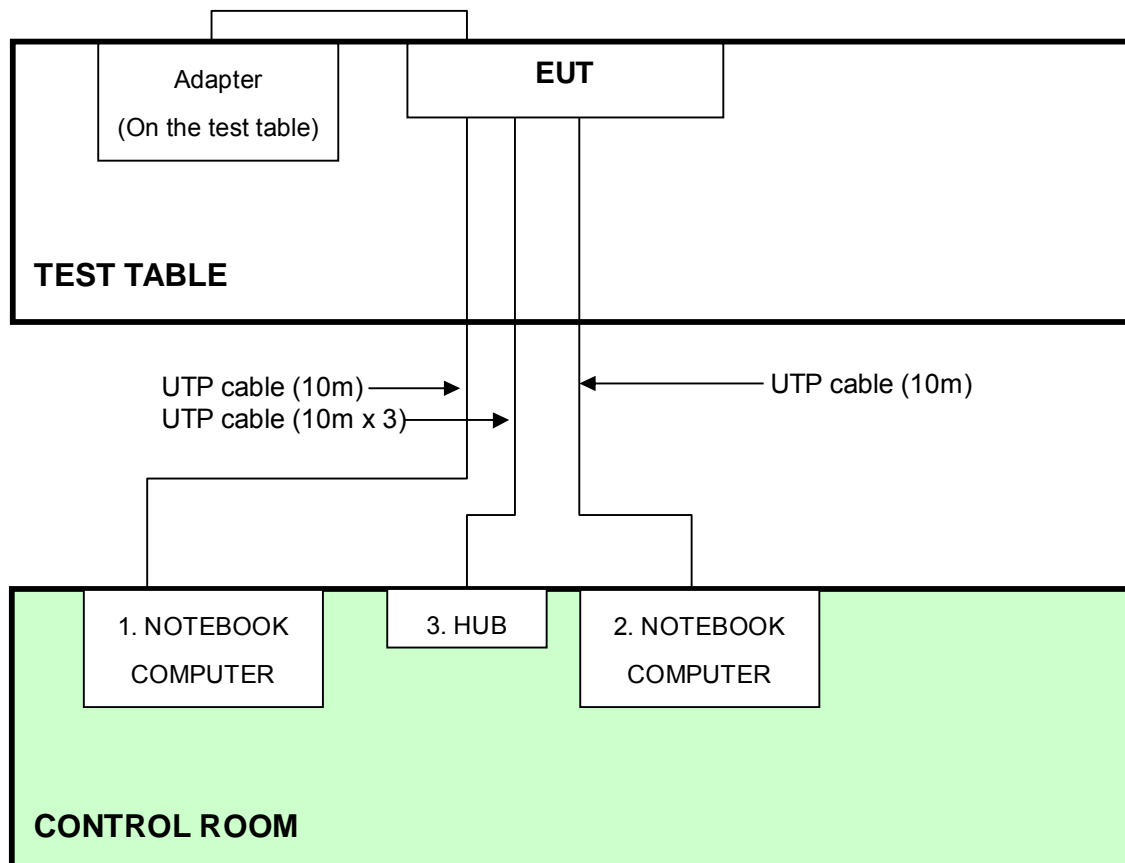



A D T

4. TEST TYPES AND RESULTS

4.1 CONDUCTED EMISSION MEASUREMENT

4.1.1 LIMITS OF CONDUCTED EMISSION MEASUREMENT

FREQUENCY OF EMISSION (MHz)	CONDUCTED LIMIT (dBµV)	
	Quasi-peak	Average
0.15-0.5	66 to 56	56 to 46
0.5-5	56	46
5-30	60	50

- NOTE:**
1. The lower limit shall apply at the transition frequencies.
 2. The limit decreases in line with the logarithm of the frequency in the range of 0.15 to 0.50 MHz.
 3. All emanations from a class A/B digital device or system, including any network of conductors and apparatus connected thereto, shall not exceed the level of field strengths specified above.

4.1.2 TEST INSTRUMENTS

DESCRIPTION & MANUFACTURER	MODEL NO.	SERIAL NO.	CALIBRATED DATE	CALIBRATED UNTIL
Test Receiver	ESCS 30	100375	Mar. 09, 2010	Mar. 08, 2011
Line-Impedance Stabilization Network (for EUT)	NSLK 8127	8127-522	Sep. 08, 2010	Sep. 07, 2011
Line-Impedance Stabilization Network (for Peripheral)	ESH3-Z5	848773/004	Nov. 03, 2010	Nov. 02, 2011
RF Cable (JYEBAO)	5DFB	COCCAB-002	Aug. 30, 2010	Aug. 29, 2011
50 ohms Terminator	50	3	Nov. 03, 2010	Nov. 02, 2011
Software	BV ADT_Cond_V7.3.7	NA	NA	NA

Note:

1. The calibration interval of the above test instruments is 12 months and the calibrations are traceable to NML/ROC and NIST/USA.
2. The test was performed in Shielded Room No. C.
- 3 The VCCI Con C Registration No. is C-3611.

4.1.3 TEST PROCEDURES

- a. The EUT was placed 0.4 meters from the conducting wall of the shielded room with EUT being connected to the power mains through a line impedance stabilization network (LISN). Other support units were connected to the power mains through another LISN. The two LISNs provide 50 ohm/ 50uH of coupling impedance for the measuring instrument.
- b. Both lines of the power mains connected to the EUT were checked for maximum conducted interference.
- c. The frequency range from 150kHz to 30MHz was searched. Emission levels under (Limit - 20dB) were not recorded.

4.1.4 DEVIATION FROM TEST STANDARD

No deviation

4.1.5 TEST SETUP

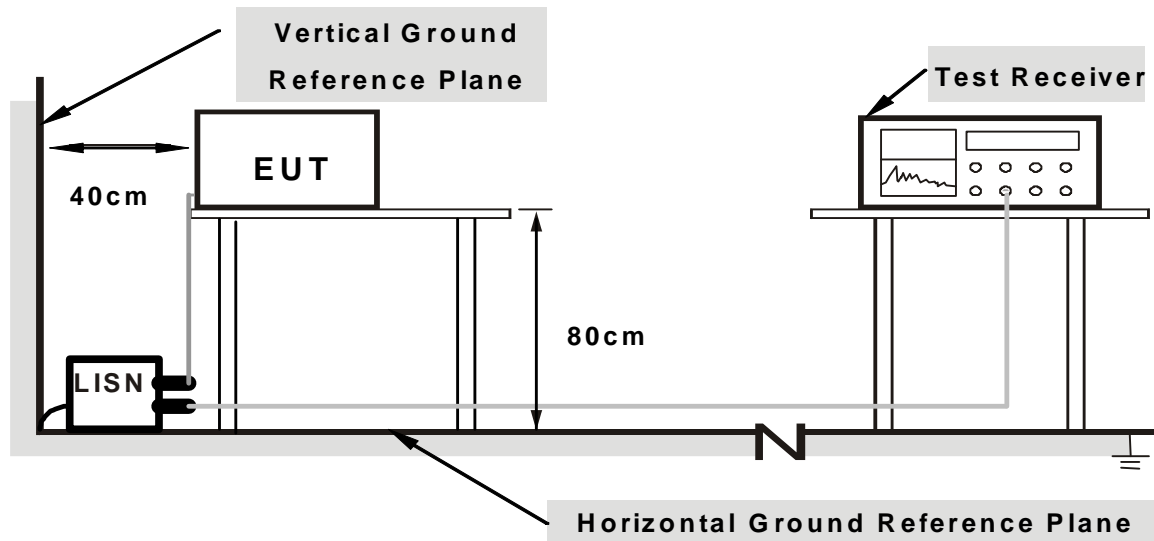

Note: 1.Support units were connected to second LISN.

2.Both of LISNs (AMN) are 80 cm from EUT and at least 80 from other units and other metal planes

For the actual test configuration, please refer to the related item – Photographs of the Test Configuration.

4.1.6 EUT OPERATING CONDITIONS

1. Turn on the power of all equipment.
2. Support units 1 ~ 3 (Notebook Computer) run a test program “Ping.exe” to enable of EUT via UTP cables and wireless continuously.

4.1.7 TEST RESULTS-MODE 1

802.11n (20MHz) OFDM MODULATION:

PHASE	Line (L)	6dB BANDWIDTH	9 kHz
-------	----------	---------------	-------

No	Freq. [MHz]	Corr. Factor (dB)	Reading Value [dB (uV)]		Emission Level [dB (uV)]		Limit [dB (uV)]		Margin (dB)	
			Q.P.	AV.	Q.P.	AV.	Q.P.	AV.	Q.P.	AV.
1	0.170	0.11	45.08	-	45.19	-	64.98	54.98	-19.79	-
2	0.213	0.13	41.07	-	41.20	-	63.10	53.10	-21.90	-
3	0.525	0.13	43.25	-	43.38	-	56.00	46.00	-12.62	-
4	1.448	0.15	33.24	-	33.39	-	56.00	46.00	-22.61	-
5	1.777	0.16	34.64	-	34.80	-	56.00	46.00	-21.20	-
6	9.432	0.45	28.12	-	28.57	-	60.00	50.00	-31.43	-

- REMARKS:**
1. Q.P. and AV. are abbreviations of quasi-peak and average individually.
 2. "-": The Quasi-peak reading value also meets average limit and measurement with the average detector is unnecessary.
 3. The emission levels of other frequencies were very low against the limit.
 4. Margin value = Emission level - Limit value
 5. Correction factor = Insertion loss + Cable loss
 6. Emission Level = Correction Factor + Reading Value.

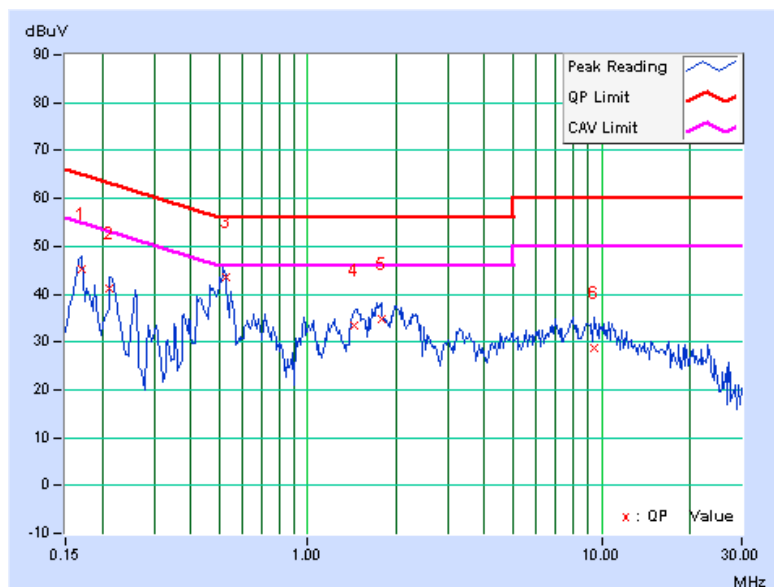

PHASE	Neutral (N)	6dB BANDWIDTH	9 kHz
-------	-------------	---------------	-------

No	Freq. [MHz]	Corr. Factor (dB)	Reading Value [dB (uV)]		Emission Level [dB (uV)]		Limit [dB (uV)]		Margin (dB)	
			Q.P.	AV.	Q.P.	AV.	Q.P.	AV.	Q.P.	AV.
			1	0.166	0.12	42.95	-	43.07	-	65.18
2	0.506	0.15	41.42	-	41.57	-	56.00	46.00	-14.43	-
3	0.717	0.16	30.79	-	30.95	-	56.00	46.00	-25.05	-
4	1.522	0.18	33.23	-	33.41	-	56.00	46.00	-22.59	-
5	2.070	0.19	32.36	-	32.55	-	56.00	46.00	-23.45	-
6	8.967	0.74	25.68	-	26.42	-	60.00	50.00	-33.58	-

- REMARKS:**
1. Q.P. and AV. are abbreviations of quasi-peak and average individually.
 2. "-": The Quasi-peak reading value also meets average limit and measurement with the average detector is unnecessary.
 3. The emission levels of other frequencies were very low against the limit.
 4. Margin value = Emission level - Limit value
 5. Correction factor = Insertion loss + Cable loss
 6. Emission Level = Correction Factor + Reading Value.

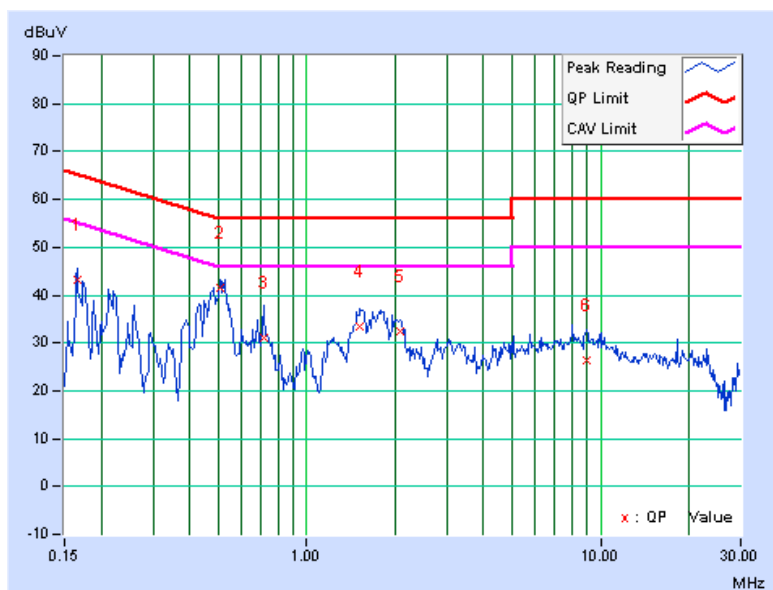

4.1.8 TEST RESULTS-MODE 2

802.11n (20MHz) OFDM MODULATION:

PHASE	Line (L)	6dB BANDWIDTH	9 kHz
--------------	----------	----------------------	-------

No	Freq. [MHz]	Corr. Factor (dB)	Reading Value		Emission Level		Limit		Margin	
			[dB (uV)]		[dB (uV)]		[dB (uV)]		(dB)	
			Q.P.	AV.	Q.P.	AV.	Q.P.	AV.	Q.P.	AV.
1	0.435	0.13	44.55	-	44.68	-	57.15	47.15	-12.47	-
2	3.665	0.19	43.32	-	43.51	-	56.00	46.00	-12.49	-
3	4.334	0.22	44.66	-	44.88	-	56.00	46.00	-11.12	-
4	5.374	0.26	45.34	-	45.60	-	60.00	50.00	-14.40	-
5	6.805	0.33	44.45	-	44.78	-	60.00	50.00	-15.22	-
6	7.947	0.38	44.41	-	44.79	-	60.00	50.00	-15.21	-

- REMARKS:**
1. Q.P. and AV. are abbreviations of quasi-peak and average individually.
 2. "-": The Quasi-peak reading value also meets average limit and measurement with the average detector is unnecessary.
 3. The emission levels of other frequencies were very low against the limit.
 4. Margin value = Emission level - Limit value
 5. Correction factor = Insertion loss + Cable loss
 6. Emission Level = Correction Factor + Reading Value.

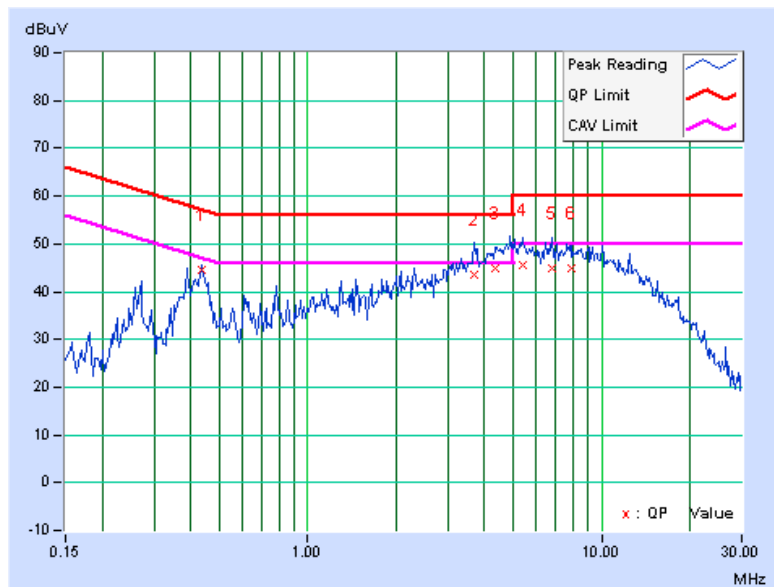

PHASE	Neutral (N)	6dB BANDWIDTH	9 kHz
--------------	-------------	----------------------	-------

No	Freq.	Corr.	Reading Value		Emission Level		Limit		Margin	
	[MHz]	Factor	[dB (uV)]		[dB (uV)]		[dB (uV)]		(dB)	
		(dB)	Q.P.	AV.	Q.P.	AV.	Q.P.	AV.	Q.P.	AV.
1	2.754	0.22	35.90	-	36.12	-	56.00	46.00	-19.88	-
2	3.477	0.26	39.06	-	39.32	-	56.00	46.00	-16.68	-
3	4.130	0.29	40.46	-	40.75	-	56.00	46.00	-15.25	-
4	5.984	0.46	41.59	-	42.05	-	60.00	50.00	-17.95	-
5	8.021	0.65	41.54	-	42.19	-	60.00	50.00	-17.81	-
6	8.760	0.72	41.11	-	41.83	-	60.00	50.00	-18.17	-

- REMARKS:**
1. Q.P. and AV. are abbreviations of quasi-peak and average individually.
 2. "-": The Quasi-peak reading value also meets average limit and measurement with the average detector is unnecessary.
 3. The emission levels of other frequencies were very low against the limit.
 4. Margin value = Emission level - Limit value
 5. Correction factor = Insertion loss + Cable loss
 6. Emission Level = Correction Factor + Reading Value.

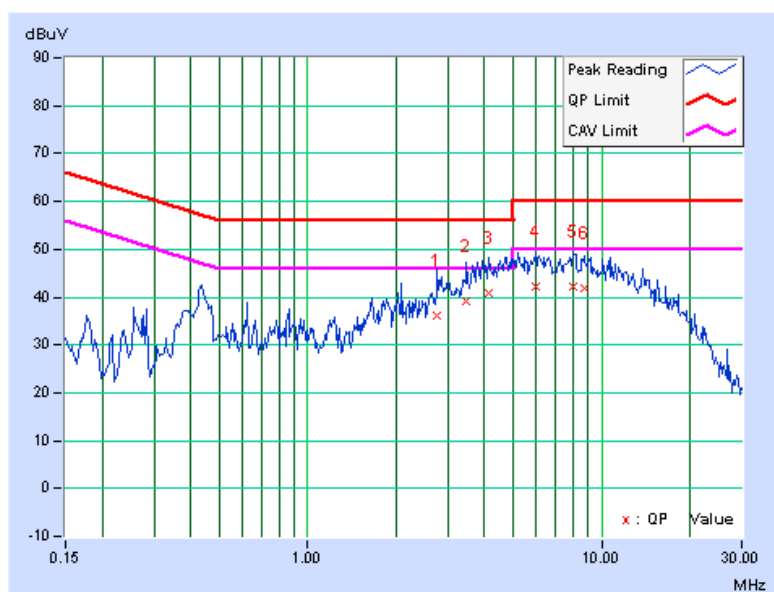

4.2 RADIATED EMISSION MEASUREMENT

4.2.1 LIMITS OF RADIATED EMISSION MEASUREMENT

Emissions radiated outside of the specified bands, shall be according to the general radiated limits in 15.209 as following:

Frequencies (MHz)	Field strength (microvolts/meter)	Measurement distance (meters)
0.009-0.490	2400/F(kHz)	300
0.490-1.705	24000/F(kHz)	30
1.705-30.0	30	30
30-88	100	3
88-216	150	3
216-960	200	3
Above 960	500	3

NOTE:

1. The lower limit shall apply at the transition frequencies.
2. Emission level (dBuV/m) = 20 log Emission level (uV/m).
3. As shown in 15.35(b), for frequencies above 1000MHz, the field strength limits are based on average detector, however, the peak field strength of any emission shall not exceed the maximum permitted average limits, specified above by more than 20dB under any condition of modulation.



A D T

4.2.2 TEST INSTRUMENTS

For Below 1GHz:

DESCRIPTION & MANUFACTURER	MODEL NO.	SERIAL NO.	CALIBRATED DATE	CALIBRATED UNTIL
Agilent Spectrum Analyzer	E4446A	MY48250253	Aug. 23, 2010	Aug. 22, 2011
Agilent Pre-Selector	N9039A	MY46520310	Aug. 23, 2010	Aug. 22, 2011
Agilent Signal Generator	N5181A	MY49060347	July 30, 2010	July 29, 2011
LIG NEX1 Test Receiver	ER-265	L09068005	Oct. 25, 2010	Oct. 24, 2011
Mini-Circuits Pre-Amplifier	ZFL-1000VH2B	AMP-ZFL-04	Nov. 16, 2010	Nov. 15, 2011
Agilent Pre-Amplifier	8449B	3008A02465	Mar. 01, 2010	Feb. 28, 2011
Miteq Pre-Amplifier	AFS33-1800265 0-30-8P-44	881786	NA	NA
SCHWARZBECK Trilog Broadband Antenna	VULB 9168	9168-361	Apr. 28, 2010	Apr. 27, 2011
AISI Horn_Antenna	AIH.8018	0000220091110	Nov. 22, 2010	Nov. 21, 2011
SCHWARZBECK Horn_Antenna	BBHA 9170	9170-424	Oct. 08, 2010	Oct. 07, 2011
RF CABLE	NA	RF104-205 RF104-207 RF104-208	Dec. 24, 2009	Dec. 23, 2010
RF Cable	NA	CHHCAB_001	NA	NA
Software	ADT_Radiated_V8.7.05	NA	NA	NA
CT Antenna Tower & Turn Table	NA	NA	NA	NA

- Note: 1. The calibration interval of the above test instruments is 12 months and the calibrations are traceable to NML/ROC and NIST/USA.
2. The horn antenna, preamplifier (model: 8449B) are used only for the measurement of emission frequency above 1GHz if tested.
3. The test was performed in 966 Chamber No. H.
4. The FCC Site Registration No. is 797305.
5. The CANADA Site Registration No. is IC 7450H-3.



A D T

For Above 1GHz:

DESCRIPTION & MANUFACTURER	MODEL NO.	SERIAL NO.	CALIBRATED DATE	CALIBRATED UNTIL
ROHDE & SCHWARZ Spectrum Analyzer	FSP40	100036	Dec. 18, 2009	Dec. 17, 2010
Agilent PSA Spectrum Analyzer	E4446A	MY46180622	May 12 , 2010	May 11 , 2011
HP Pre_Amplifier	8449B	300801923	Nov. 01, 2010	Oct. 31, 2011
ROHDE & SCHWARZ Test Receiver	ESCS30	847124/029	Sep. 03, 2010	Sep. 02, 2011
SCHWARZBECK TRILOG Broadband Antenna	VULB 9168	138	Apr. 28, 2010	Apr. 27, 2011
Schwarzbeck Horn_Antenna	BBHA9120	D124	Dec. 18, 2009	Dec. 17, 2010
Schwarzbeck Horn_Antenna	BBHA 9170	BBHA9170153	Jan. 22, 2010	Jan. 21, 2011
RF Switches	EMH-011	1001	NA	NA
RF CABLE (Chaintek)	Sucoflex 104+ Sucoflex 106	RF104-101+R F106-101	Aug. 24, 2010	Aug. 23, 2011
RF Cable	8DFB	STCCAB-30M- 1GHz	NA	NA
Software	ADT_Radiated_ V7.6.15.9.2	NA	NA	NA
CT Antenna Tower & Turn Table	NA	NA	NA	NA

- Note: 1. The calibration interval of the above test instruments is 12 months and the calibrations are traceable to NML/ROC and NIST/USA.
2. The horn antenna, preamplifier (model: 8449B) and Spectrum Analyzer (model: FSP40) are used only for the measurement of emission frequency above 1GHz if tested.
3. The test was performed in Open Site No. C.
4. The FCC Site Registration No. is 656396.
5. The VCCI Site Registration No. is R-1626.
6. The CANADA Site Registration No. is IC 7450G-3.



A D T

4.2.3 TEST PROCEDURES

- a. The EUT was placed on the top of a rotating table 0.8 meters above the ground at 3 meters chamber room for below 1GHz test and 10 meters open field site for above 1GHz test. The table was rotated 360 degrees to determine the position of the highest radiation.
- b. The EUT was set 3 meters away from the interference-receiving antenna, which was mounted on the top of a variable-height antenna tower.
- c. The height of antenna is varied from one meter to four meters above the ground to determine the maximum value of the field strength. Both horizontal and vertical polarizations of the antenna are set to make the measurement.
- d. For each suspected emission, the EUT was arranged to its worst case and then the antenna was tuned to heights from 1 meter to 4 meters and the rotatable table was turned from 0 degrees to 360 degrees to find the maximum reading.
- e. The test-receiver system was set to quasi-peak detect function and specified bandwidth with maximum hold mode when the test frequency is below 1 GHz.
- f. The test-receiver system was set to peak and average detect function and specified bandwidth with maximum hold mode when the test frequency is above 1 GHz. If the peak reading value also meets average limit, measurement with the average detector is unnecessary.

NOTE:

1. The resolution bandwidth and video bandwidth of test receiver/spectrum analyzer is 120kHz for Peak detection (PK) and Quasi-peak detection (QP) at frequency below 1GHz.
2. The resolution bandwidth of test receiver/spectrum analyzer is 1 MHz and video bandwidth is 3MHz for Peak detection at frequency above 1GHz.
3. The resolution bandwidth of test receiver/spectrum analyzer is 1MHz and the video bandwidth is 10Hz for Average detection (AV) at frequency above 1GHz.

4.2.4 DEVIATION FROM TEST STANDARD

No deviation

4.2.5 TEST SETUP

< Frequency Range below 1GHz >

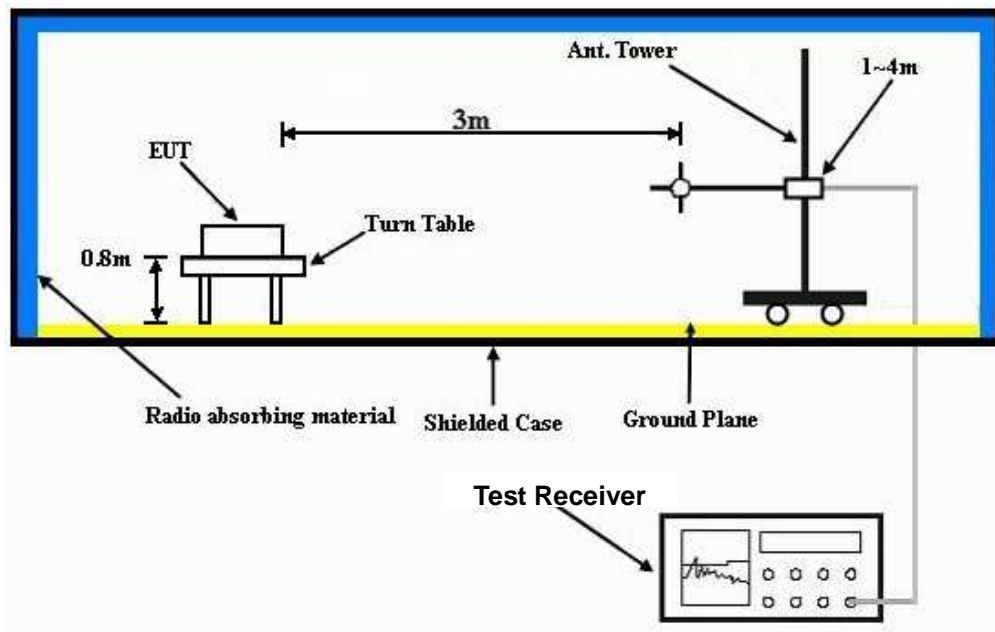

< Frequency Range above 1GHz >

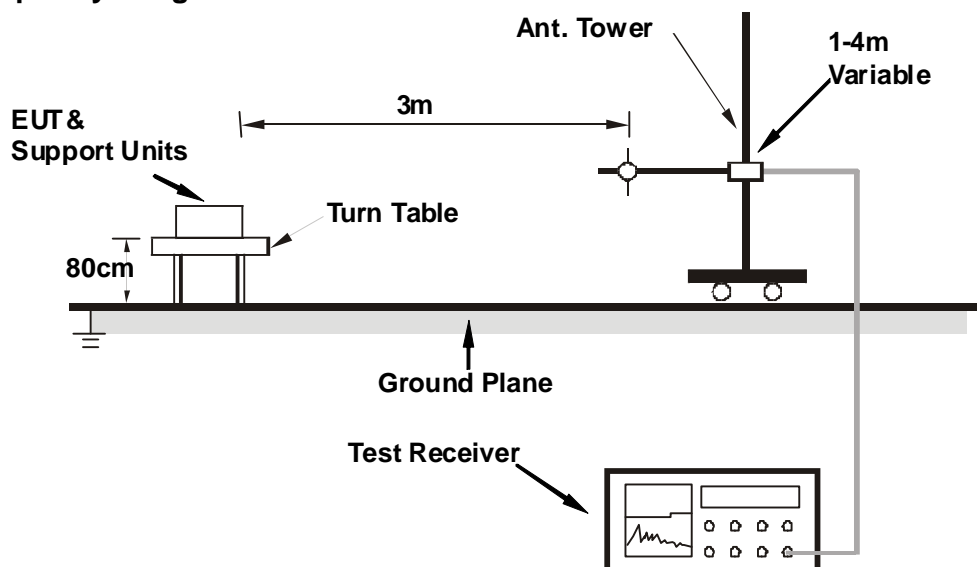

For the actual test configuration, please refer to the related item – Photographs of the Test Configuration.

4.2.6 EUT OPERATING CONDITIONS

1. Turn on the power of all equipment.
2. Support unit 2 (Notebook Computer) runs a test program “BCM command” to enable of EUT via UTP cable.



A D T

4.2.7 TEST RESULTS

BELOW 1GHz WORST-CASE DATA : 802.11n (20MHz) OFDM MODULATION

EUT TEST CONDITION		MEASUREMENT DETAIL	
CHANNEL	Channel 6	FREQUENCY RANGE	Below 1000MHz
INPUT POWER	120Vac, 60 Hz	DETECTOR FUNCTION	Quasi-Peak
ENVIRONMENTAL CONDITIONS	27deg. C, 72%RH 1013 hPa	TESTED BY	Eric Lee

ANTENNA POLARITY & TEST DISTANCE: HORIZONTAL AT 3 M								
NO.	FREQ. (MHz)	EMISSION LEVEL (dBuV/m)	LIMIT (dBuV/m)	MARGIN (dB)	ANTENNA HEIGHT (m)	TABLE ANGLE (Degree)	RAW VALUE (dBuV)	CORRECTION FACTOR (dB/m)
1	148.07	36.4 QP	43.5	-7.1	1.25 H	291	22.14	14.27
2	218.65	29.3 QP	46.0	-16.7	1.00 H	82	17.43	11.86
3	223.38	34.0 QP	46.0	-12.0	1.25 H	110	21.95	12.02
4	250.03	35.1 QP	46.0	-10.9	1.00 H	45	22.11	12.95
5	374.97	35.5 QP	46.0	-10.5	1.00 H	265	18.30	17.18
6	380.06	37.7 QP	46.0	-8.3	1.00 H	329	20.34	17.33
7	399.95	37.9 QP	46.0	-8.1	1.00 H	171	19.92	17.94
8	500.02	42.4 QP	46.0	-3.6	1.75 H	351	22.31	20.11
9	599.97	35.7 QP	46.0	-10.3	1.50 H	15	13.13	22.54
10	750.01	33.3 QP	46.0	-12.7	1.25 H	0	9.04	24.28

ANTENNA POLARITY & TEST DISTANCE: VERTICAL AT 3 M								
NO.	FREQ. (MHz)	EMISSION LEVEL (dBuV/m)	LIMIT (dBuV/m)	MARGIN (dB)	ANTENNA HEIGHT (m)	TABLE ANGLE (Degree)	RAW VALUE (dBuV)	CORRECTION FACTOR (dB/m)
1	47.76	36.3 QP	40.0	-3.7	1.00 V	360	21.76	14.58
2	62.80	36.1 QP	40.0	-3.9	1.00 V	101	23.15	12.91
3	77.25	34.8 QP	40.0	-5.2	1.00 V	266	24.28	10.54
4	91.82	33.1 QP	43.5	-10.4	1.25 V	268	23.41	9.69
5	108.75	34.2 QP	43.5	-9.3	1.00 V	3	23.01	11.19
6	143.33	37.1 QP	43.5	-6.4	1.00 V	118	22.86	14.21
7	250.03	36.1 QP	46.0	-9.9	1.00 V	0	23.18	12.95
8	374.97	35.4 QP	46.0	-10.6	1.25 V	285	18.24	17.18
9	399.95	36.6 QP	46.0	-9.4	1.25 V	297	18.63	17.94
10	500.02	39.6 QP	46.0	-6.4	1.25 V	99	19.49	20.11

- REMARKS:**
1. Emission level (dBuV/m) = Raw Value (dBuV) + Correction Factor (dB/m).
 2. Correction Factor (dB/m) = Antenna Factor (dB/m) + Cable Factor (dB).
 3. The other emission levels were very low against the limit.
 4. Margin value = Emission level – Limit value.



A D T

ABOVE 1GHz WORST-CASE DATA

802.11b DSSS MODULATION

EUT TEST CONDITION		MEASUREMENT DETAIL	
CHANNEL	Channel 1	FREQUENCY RANGE	1 ~ 25GHz
INPUT POWER	120Vac, 60 Hz	DETECTOR FUNCTION	Peak (PK) Average (AV)
ENVIRONMENTAL CONDITIONS	25deg. C, 67%RH 1013 hPa	TESTED BY	Frank Liu

ANTENNA POLARITY & TEST DISTANCE: HORIZONTAL AT 3 M								
NO.	FREQ. (MHz)	EMISSION LEVEL (dBuV/m)	LIMIT (dBuV/m)	MARGIN (dB)	ANTENNA HEIGHT (m)	TABLE ANGLE (Degree)	RAW VALUE (dBuV)	CORRECTION FACTOR (dB/m)
1	2390.00	55.5 PK	74.0	-18.5	1.02 H	294	24.50	31.00
2	2390.00	43.8 AV	54.0	-10.2	1.02 H	294	12.80	31.00
3	*2412.00	98.7 PK			1.02 H	294	67.60	31.10
4	*2412.00	95.1 AV			1.02 H	294	64.00	31.10
5	4824.00	54.3 PK	74.0	-19.7	1.71 H	87	17.20	37.10
6	4824.00	52.3 AV	54.0	-1.7	1.71 H	87	15.20	37.10
ANTENNA POLARITY & TEST DISTANCE: VERTICAL AT 3 M								
NO.	FREQ. (MHz)	EMISSION LEVEL (dBuV/m)	LIMIT (dBuV/m)	MARGIN (dB)	ANTENNA HEIGHT (m)	TABLE ANGLE (Degree)	RAW VALUE (dBuV)	CORRECTION FACTOR (dB/m)
1	2390.00	59.6 PK	74.0	-14.4	1.00 V	113	28.60	31.00
2	2390.00	47.8 AV	54.0	-6.2	1.00 V	113	16.80	31.00
3	*2412.00	111.2 PK			1.00 V	113	80.10	31.10
4	*2412.00	108.5 AV			1.00 V	113	77.40	31.10
5	4824.00	52.7 PK	74.0	-21.3	1.55 V	8	15.60	37.10
6	4824.00	50.0 AV	54.0	-4.0	1.55 V	8	12.90	37.10
7	12060.00	57.8 PK	74.0	-16.2	1.54 V	172	8.00	49.80
8	12060.00	49.7 AV	54.0	-4.3	1.54 V	172	-0.10	49.80
9	14472.00	61.7 PK	74.0	-12.3	1.33 V	328	9.50	52.20
10	14472.00	52.6 AV	54.0	-1.4	1.33 V	328	0.40	52.20

- REMARKS:**
1. Emission level (dBuV/m) = Raw Value (dBuV) + Correction Factor (dB/m).
 2. Correction Factor (dB/m) = Antenna Factor (dB/m) + Cable Factor (dB).
 3. The other emission levels were very low against the limit.
 4. Margin value = Emission level – Limit value.
 5. “ * ”: Fundamental frequency.



A D T

EUT TEST CONDITION		MEASUREMENT DETAIL	
CHANNEL	Channel 6	FREQUENCY RANGE	1 ~ 25GHz
INPUT POWER	120Vac, 60 Hz	DETECTOR FUNCTION	Peak (PK) Average (AV)
ENVIRONMENTAL CONDITIONS	25deg. C, 67%RH 1013 hPa	TESTED BY	Frank Liu

ANTENNA POLARITY & TEST DISTANCE: HORIZONTAL AT 3 M								
NO.	FREQ. (MHz)	EMISSION LEVEL (dBuV/m)	LIMIT (dBuV/m)	MARGIN (dB)	ANTENNA HEIGHT (m)	TABLE ANGLE (Degree)	RAW VALUE (dBuV)	CORRECTION FACTOR (dB/m)
1	*2437.00	99.6 PK			1.07 H	283	68.40	31.20
2	*2437.00	96.4 AV			1.07 H	283	65.20	31.20
3	4874.00	54.8 PK	74.0	-19.2	1.64 H	63	17.60	37.20
4	4874.00	52.4 AV	54.0	-1.6	1.64 H	63	15.20	37.20
5	7311.00	55.1 PK	74.0	-18.9	1.37 H	162	10.70	44.40
6	7311.00	48.9 AV	54.0	-5.1	1.37 H	162	4.50	44.40

ANTENNA POLARITY & TEST DISTANCE: VERTICAL AT 3 M								
NO.	FREQ. (MHz)	EMISSION LEVEL (dBuV/m)	LIMIT (dBuV/m)	MARGIN (dB)	ANTENNA HEIGHT (m)	TABLE ANGLE (Degree)	RAW VALUE (dBuV)	CORRECTION FACTOR (dB/m)
1	*2437.00	111.9 PK			1.00 V	109	80.70	31.20
2	*2437.00	109.1 AV			1.00 V	109	77.90	31.20
3	4874.00	53.1 PK	74.0	-20.9	1.52 V	67	15.90	37.20
4	4874.00	51.3 AV	54.0	-2.7	1.52 V	67	14.10	37.20
5	7311.00	56.2 PK	74.0	-17.8	1.65 V	175	11.80	44.40
6	7311.00	53.5 AV	54.0	-0.5	1.65 V	175	9.10	44.40
7	12185.00	61.9 PK	74.0	-12.1	1.34 V	339	12.20	49.70
8	12185.00	52.7 AV	54.0	-1.3	1.34 V	339	3.00	49.70

- REMARKS:**
1. Emission level (dBuV/m) = Raw Value (dBuV) + Correction Factor (dB/m).
 2. Correction Factor (dB/m) = Antenna Factor (dB/m) + Cable Factor (dB).
 3. The other emission levels were very low against the limit.
 4. Margin value = Emission level – Limit value.
 5. “ * “: Fundamental frequency.



A D T

EUT TEST CONDITION		MEASUREMENT DETAIL	
CHANNEL	Channel 11	FREQUENCY RANGE	1 ~ 25GHz
INPUT POWER	120Vac, 60 Hz	DETECTOR FUNCTION	Peak (PK) Average (AV)
ENVIRONMENTAL CONDITIONS	25deg. C, 67%RH 1013 hPa	TESTED BY	Frank Liu

ANTENNA POLARITY & TEST DISTANCE: HORIZONTAL AT 3 M								
NO.	FREQ. (MHz)	EMISSION LEVEL (dBuV/m)	LIMIT (dBuV/m)	MARGIN (dB)	ANTENNA HEIGHT (m)	TABLE ANGLE (Degree)	RAW VALUE (dBuV)	CORRECTION FACTOR (dB/m)
1	*2462.00	98.9 PK			1.02 H	294	67.60	31.30
2	*2462.00	95.2 AV			1.02 H	294	63.90	31.30
3	2483.50	54.7 PK	74.0	-19.3	1.02 H	294	23.30	31.40
4	2483.50	43.1 AV	54.0	-10.9	1.02 H	294	11.70	31.40
5	4924.00	54.6 PK	74.0	-19.4	1.69 H	72	17.30	37.30
6	4924.00	52.1 AV	54.0	-1.9	1.69 H	72	14.80	37.30
7	7386.00	55.3 PK	74.0	-18.7	1.35 H	185	10.70	44.60
8	7386.00	48.8 AV	54.0	-5.2	1.35 H	185	4.20	44.60
ANTENNA POLARITY & TEST DISTANCE: VERTICAL AT 3 M								
NO.	FREQ. (MHz)	EMISSION LEVEL (dBuV/m)	LIMIT (dBuV/m)	MARGIN (dB)	ANTENNA HEIGHT (m)	TABLE ANGLE (Degree)	RAW VALUE (dBuV)	CORRECTION FACTOR (dB/m)
1	*2462.00	111.1 PK			1.00 V	119	79.80	31.30
2	*2462.00	108.2 AV			1.00 V	119	76.90	31.30
3	2483.50	62.5 PK	74.0	-11.5	1.00 V	277	31.10	31.40
4	2483.50	49.8 AV	54.0	-4.2	1.00 V	277	18.40	31.40
5	4924.00	52.4 PK	74.0	-21.6	1.07 V	272	15.10	37.30
6	4924.00	49.6 AV	54.0	-4.4	1.07 V	272	12.30	37.30
7	7386.00	55.4 PK	74.0	-18.6	1.48 V	192	10.80	44.60
8	7386.00	50.0 AV	54.0	-4.0	1.48 V	192	5.40	44.60
9	12310.00	58.5 PK	74.0	-15.5	1.49 V	139	8.80	49.70
10	12310.00	51.5 AV	54.0	-2.5	1.49 V	139	1.80	49.70

- REMARKS:**
1. Emission level (dBuV/m) = Raw Value (dBuV) + Correction Factor (dB/m).
 2. Correction Factor (dB/m) = Antenna Factor (dB/m) + Cable Factor (dB).
 3. The other emission levels were very low against the limit.
 4. Margin value = Emission level – Limit value.
 5. “ * “: Fundamental frequency.



A D T

RESTRICTED BANDEDGE (802.11b MODE, CH1, HORIZONTAL)

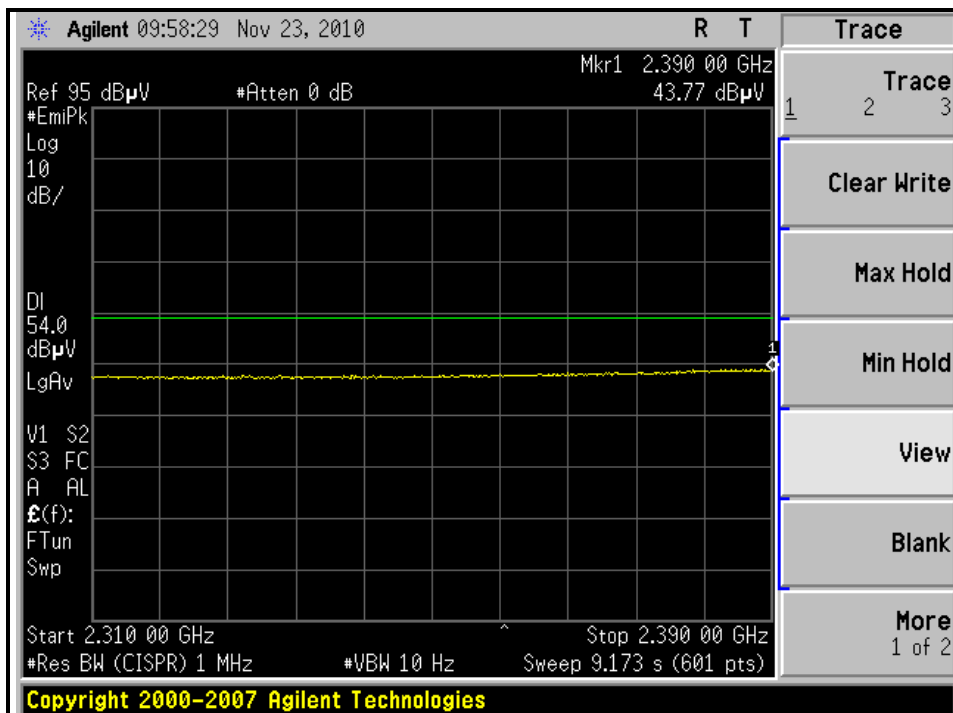
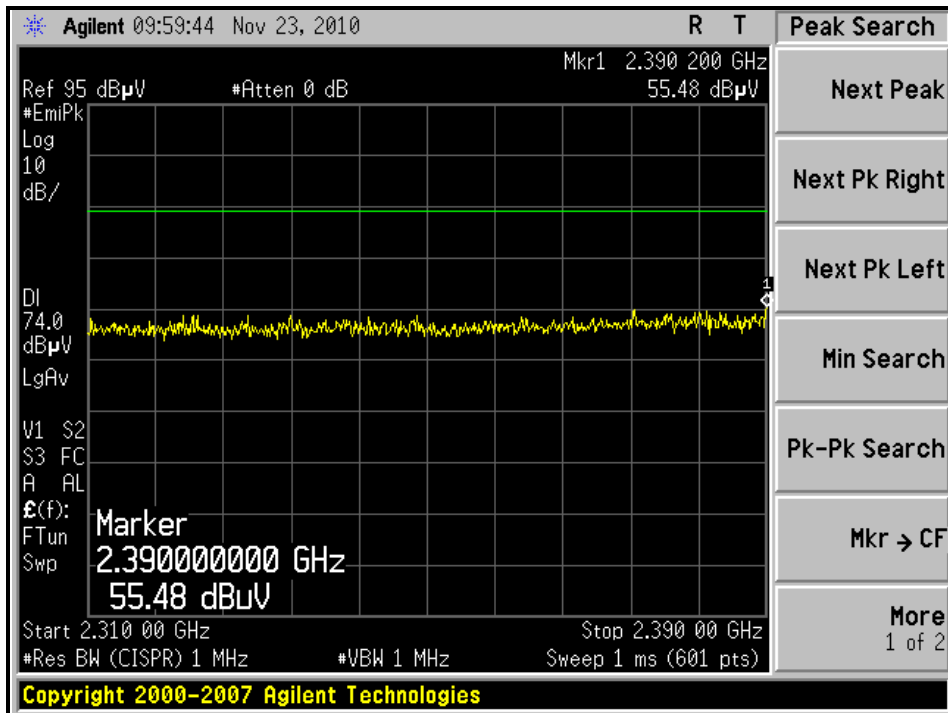



A D T

RESTRICTED BANDEDGE (802.11b MODE, CH1, VERTICAL)

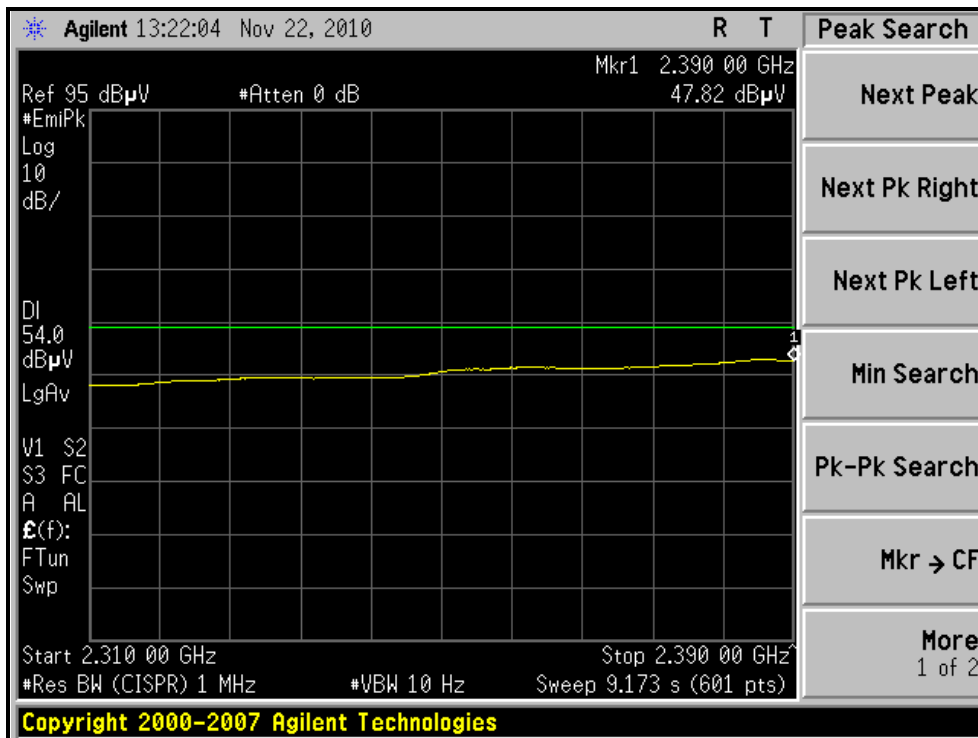
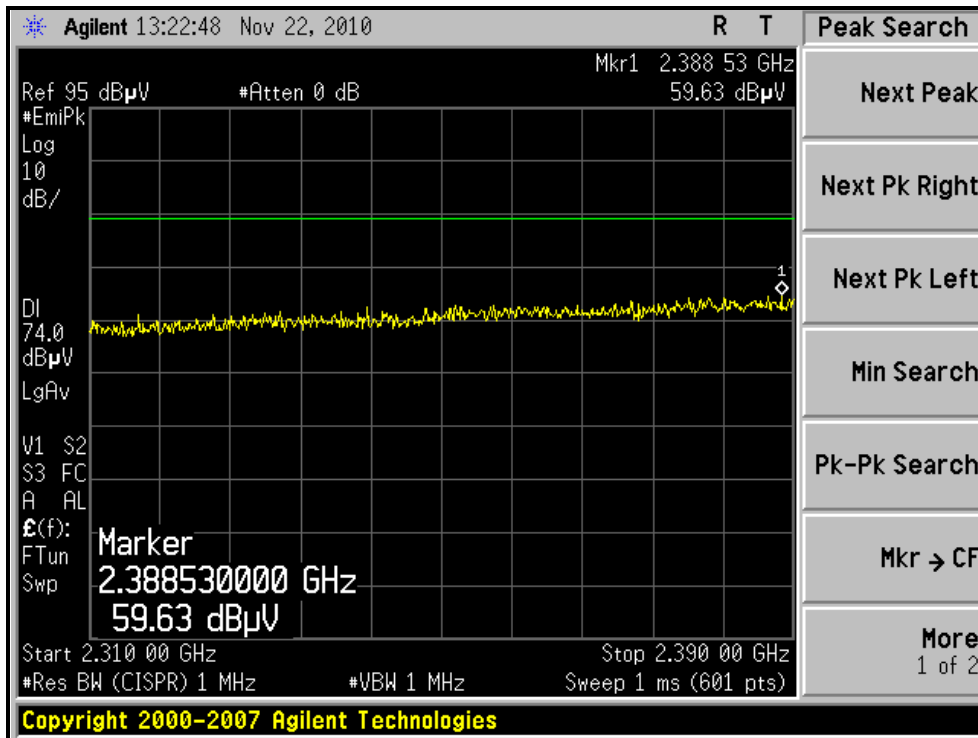



A D T

RESTRICTED BANDEDGE (802.11b MODE,CH11, HORIZONTAL)

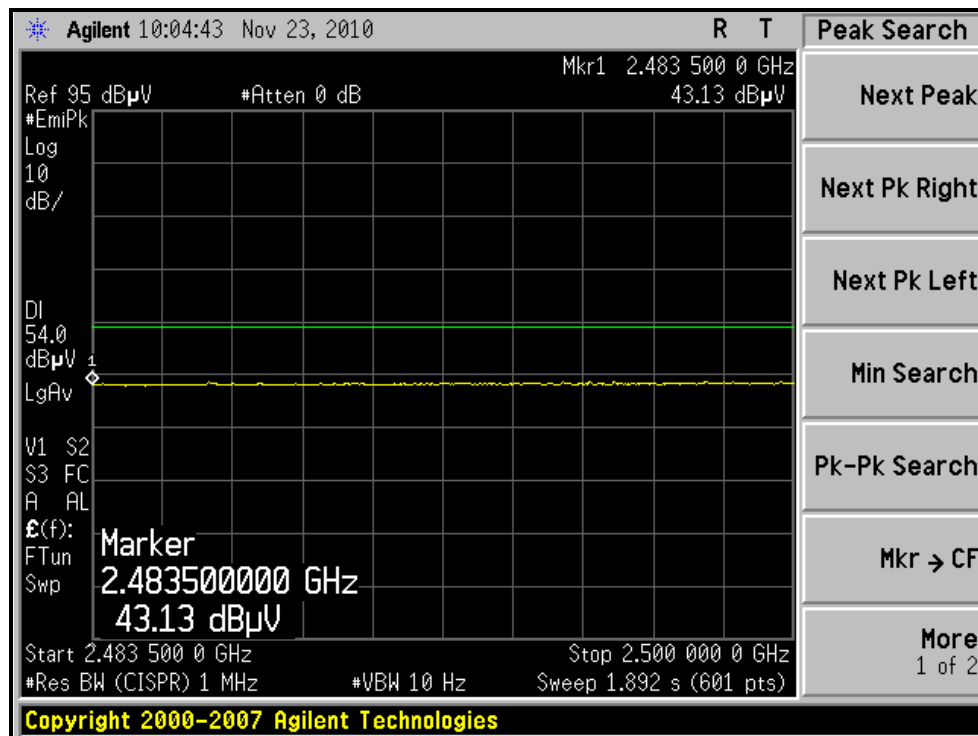
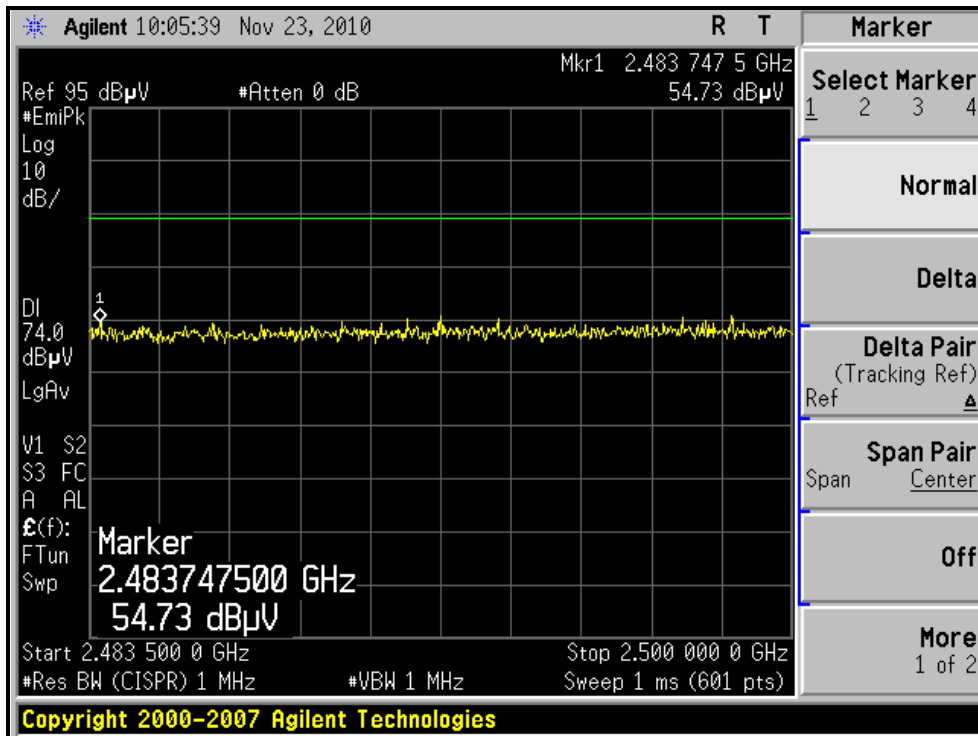



A D T

RESTRICTED BANDEDGE (802.11b MODE, CH11, VERTICAL)

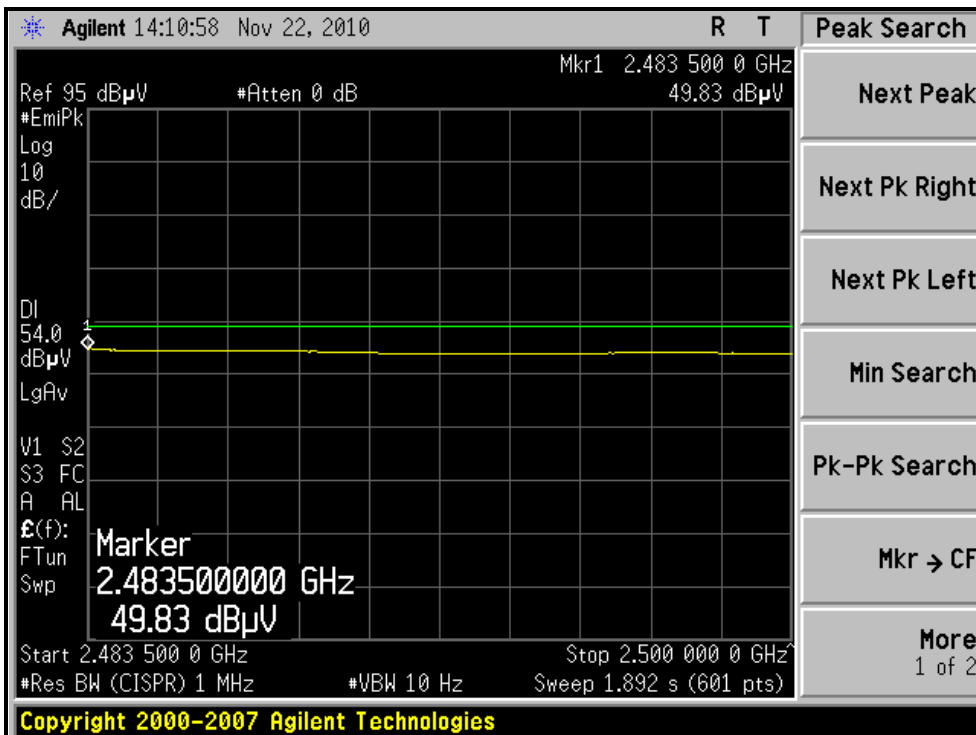
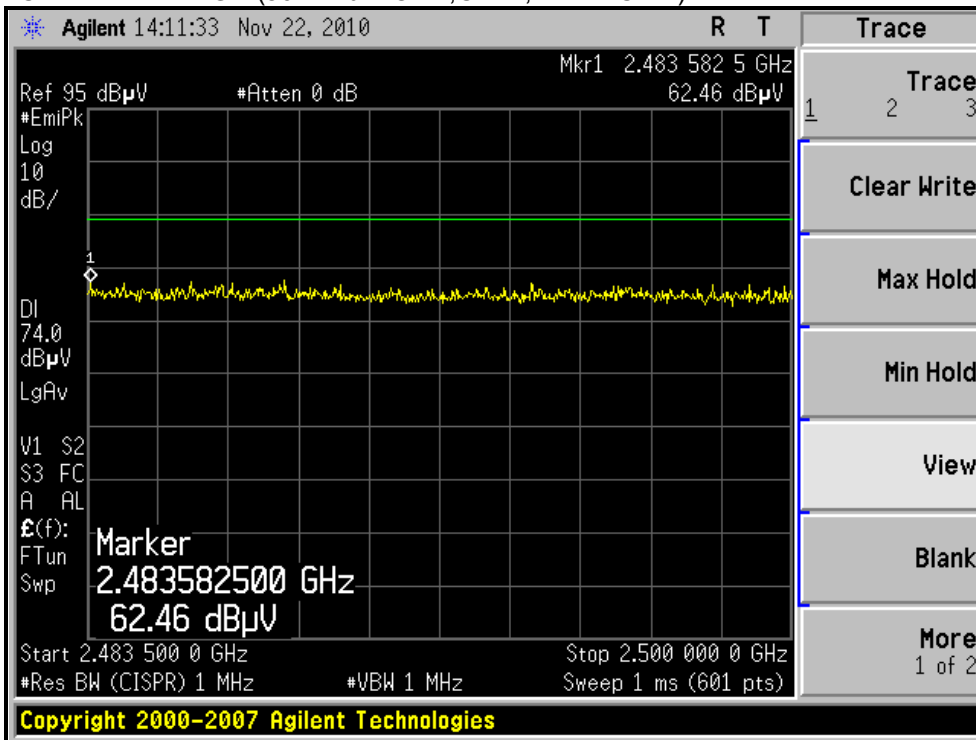



A D T

802.11g OFDM MODULATION

EUT TEST CONDITION		MEASUREMENT DETAIL	
CHANNEL	Channel 1	FREQUENCY RANGE	1 ~ 25GHz
INPUT POWER	120Vac, 60 Hz	DETECTOR FUNCTION	Peak (PK) Average (AV)
ENVIRONMENTAL CONDITIONS	25deg. C, 67%RH 1013 hPa	TESTED BY	Frank Liu

ANTENNA POLARITY & TEST DISTANCE: HORIZONTAL AT 3 M								
NO.	FREQ. (MHz)	EMISSION LEVEL (dBuV/m)	LIMIT (dBuV/m)	MARGIN (dB)	ANTENNA HEIGHT (m)	TABLE ANGLE (Degree)	RAW VALUE (dBuV)	CORRECTION FACTOR (dB/m)
1	2390.00	55.3 PK	74.0	-18.7	1.35 H	294	24.30	31.00
2	2390.00	44.4 AV	54.0	-9.6	1.35 H	294	13.40	31.00
3	*2412.00	97.4 PK			1.03 H	294	66.30	31.10
4	*2412.00	87.0 AV			1.03 H	294	55.90	31.10
5	4824.00	43.2 PK	74.0	-30.8	1.00 H	184	6.10	37.10
6	4824.00	34.1 AV	54.0	-19.9	1.00 H	184	-3.00	37.10
ANTENNA POLARITY & TEST DISTANCE: VERTICAL AT 3 M								
NO.	FREQ. (MHz)	EMISSION LEVEL (dBuV/m)	LIMIT (dBuV/m)	MARGIN (dB)	ANTENNA HEIGHT (m)	TABLE ANGLE (Degree)	RAW VALUE (dBuV)	CORRECTION FACTOR (dB/m)
1	2390.00	67.0 PK	74.0	-7.0	1.00 V	113	36.00	31.00
2	2390.00	52.2 AV	54.0	-1.8	1.00 V	113	21.20	31.00
3	*2412.00	109.9 PK			1.00 V	304	78.80	31.10
4	*2412.00	100.0 AV			1.00 V	304	68.90	31.10
5	4824.00	45.7 PK	74.0	-28.3	1.52 V	73	8.60	37.10
6	4824.00	37.2 AV	54.0	-16.8	1.52 V	73	0.10	37.10

- REMARKS:**
1. Emission level (dBuV/m) = Raw Value (dBuV) + Correction Factor (dB/m).
 2. Correction Factor (dB/m) = Antenna Factor (dB/m) + Cable Factor (dB).
 3. The other emission levels were very low against the limit.
 4. Margin value = Emission level – Limit value.
 5. “ * “: Fundamental frequency.



A D T

EUT TEST CONDITION		MEASUREMENT DETAIL	
CHANNEL	Channel 6	FREQUENCY RANGE	1 ~ 25GHz
INPUT POWER	120Vac, 60 Hz	DETECTOR FUNCTION	Peak (PK) Average (AV)
ENVIRONMENTAL CONDITIONS	25deg. C, 67%RH 1013 hPa	TESTED BY	Frank Liu

ANTENNA POLARITY & TEST DISTANCE: HORIZONTAL AT 3 M								
NO.	FREQ. (MHz)	EMISSION LEVEL (dBuV/m)	LIMIT (dBuV/m)	MARGIN (dB)	ANTENNA HEIGHT (m)	TABLE ANGLE (Degree)	RAW VALUE (dBuV)	CORRECTION FACTOR (dB/m)
1	*2437.00	98.6 PK			1.04 H	283	67.40	31.20
2	*2437.00	88.4 AV			1.04 H	283	57.20	31.20
3	4874.00	44.6 PK	74.0	-29.4	1.00 H	187	7.40	37.20
4	4874.00	35.7 AV	54.0	-18.3	1.00 H	187	-1.50	37.20
5	7311.00	50.4 PK	74.0	-23.6	1.34 H	154	6.00	44.40
6	7311.00	38.6 AV	54.0	-15.4	1.34 H	154	-5.80	44.40
ANTENNA POLARITY & TEST DISTANCE: VERTICAL AT 3 M								
NO.	FREQ. (MHz)	EMISSION LEVEL (dBuV/m)	LIMIT (dBuV/m)	MARGIN (dB)	ANTENNA HEIGHT (m)	TABLE ANGLE (Degree)	RAW VALUE (dBuV)	CORRECTION FACTOR (dB/m)
1	*2437.00	111.6 PK			1.00 V	65	80.40	31.20
2	*2437.00	101.1 AV			1.00 V	65	69.90	31.20
3	4874.00	47.3 PK	74.0	-26.7	1.54 V	69	10.10	37.20
4	4874.00	40.2 AV	54.0	-13.8	1.54 V	69	3.00	37.20
5	7311.00	58.5 PK	74.0	-15.5	1.11 V	333	14.10	44.40
6	7311.00	45.2 AV	54.0	-8.8	1.11 V	333	0.80	44.40

- REMARKS:**
1. Emission level (dBuV/m) = Raw Value (dBuV) + Correction Factor (dB/m).
 2. Correction Factor (dB/m) = Antenna Factor (dB/m) + Cable Factor (dB).
 3. The other emission levels were very low against the limit.
 4. Margin value = Emission level – Limit value.
 5. “ * “: Fundamental frequency.



A D T

EUT TEST CONDITION		MEASUREMENT DETAIL	
CHANNEL	Channel 11	FREQUENCY RANGE	1 ~ 25GHz
INPUT POWER	120Vac, 60 Hz	DETECTOR FUNCTION	Peak (PK) Average (AV)
ENVIRONMENTAL CONDITIONS	25deg. C, 67%RH 1013 hPa	TESTED BY	Frank Liu

ANTENNA POLARITY & TEST DISTANCE: HORIZONTAL AT 3 M								
NO.	FREQ. (MHz)	EMISSION LEVEL (dBuV/m)	LIMIT (dBuV/m)	MARGIN (dB)	ANTENNA HEIGHT (m)	TABLE ANGLE (Degree)	RAW VALUE (dBuV)	CORRECTION FACTOR (dB/m)
1	*2462.00	97.3 PK			1.28 H	290	66.00	31.30
2	*2462.00	87.1 AV			1.28 H	290	55.80	31.30
3	2483.50	57.1 PK	74.0	-16.9	1.28 H	290	25.70	31.40
4	2483.50	43.2 AV	54.0	-10.8	1.28 H	290	11.80	31.40
5	4924.00	43.1 PK	74.0	-30.9	1.00 H	184	5.80	37.30
6	4924.00	34.2 AV	54.0	-19.8	1.00 H	184	-3.10	37.30
7	7386.00	50.1 PK	74.0	-23.9	1.31 H	157	5.50	44.60
8	7386.00	38.2 AV	54.0	-15.8	1.31 H	157	-6.40	44.60
ANTENNA POLARITY & TEST DISTANCE: VERTICAL AT 3 M								
NO.	FREQ. (MHz)	EMISSION LEVEL (dBuV/m)	LIMIT (dBuV/m)	MARGIN (dB)	ANTENNA HEIGHT (m)	TABLE ANGLE (Degree)	RAW VALUE (dBuV)	CORRECTION FACTOR (dB/m)
1	*2462.00	111.0 PK			1.00 V	301	79.70	31.30
2	*2462.00	100.0 AV			1.00 V	301	68.70	31.30
3	2483.50	69.9 PK	74.0	-4.1	1.00 V	271	38.50	31.40
4	2483.50	48.4 AV	54.0	-5.6	1.00 V	271	17.00	31.40
5	4924.00	45.2 PK	74.0	-28.8	1.00 V	124	7.90	37.30
6	4924.00	37.1 AV	54.0	-16.9	1.00 V	124	-0.20	37.30
7	7386.00	56.4 PK	74.0	-17.6	1.10 V	321	11.80	44.60
8	7386.00	41.2 AV	54.0	-12.8	1.10 V	321	-3.40	44.60

- REMARKS:**
1. Emission level (dBuV/m) = Raw Value (dBuV) + Correction Factor (dB/m).
 2. Correction Factor (dB/m) = Antenna Factor (dB/m) + Cable Factor (dB).
 3. The other emission levels were very low against the limit.
 4. Margin value = Emission level – Limit value.
 5. “ * “: Fundamental frequency.



A D T

RESTRICTED BANDEDGE (802.11g MODE,CH1, HORIZONTAL)

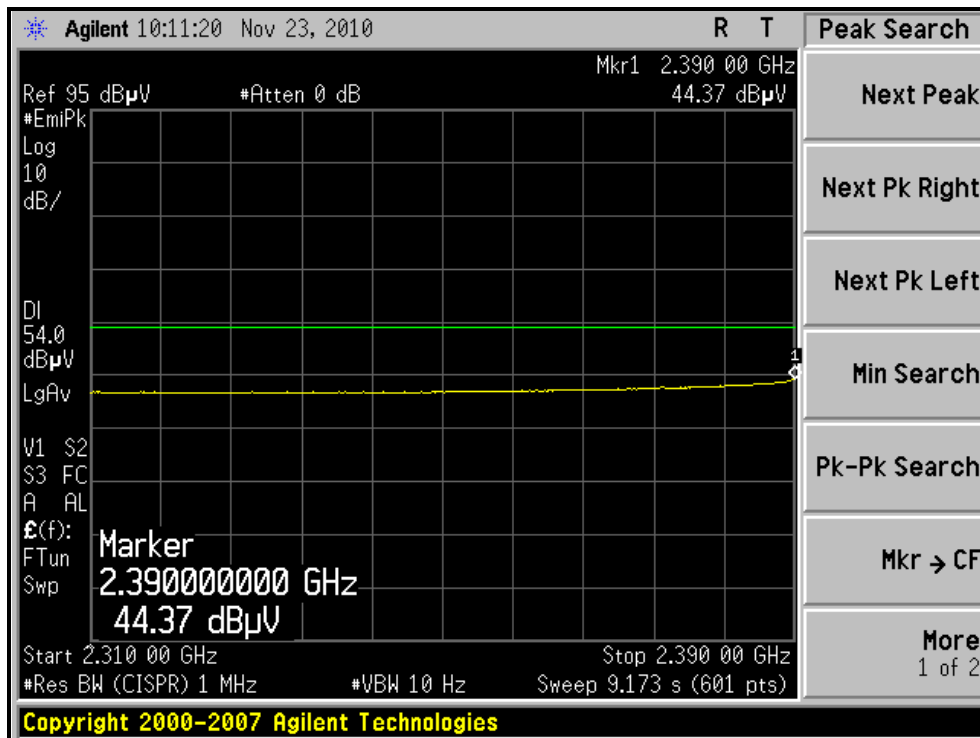
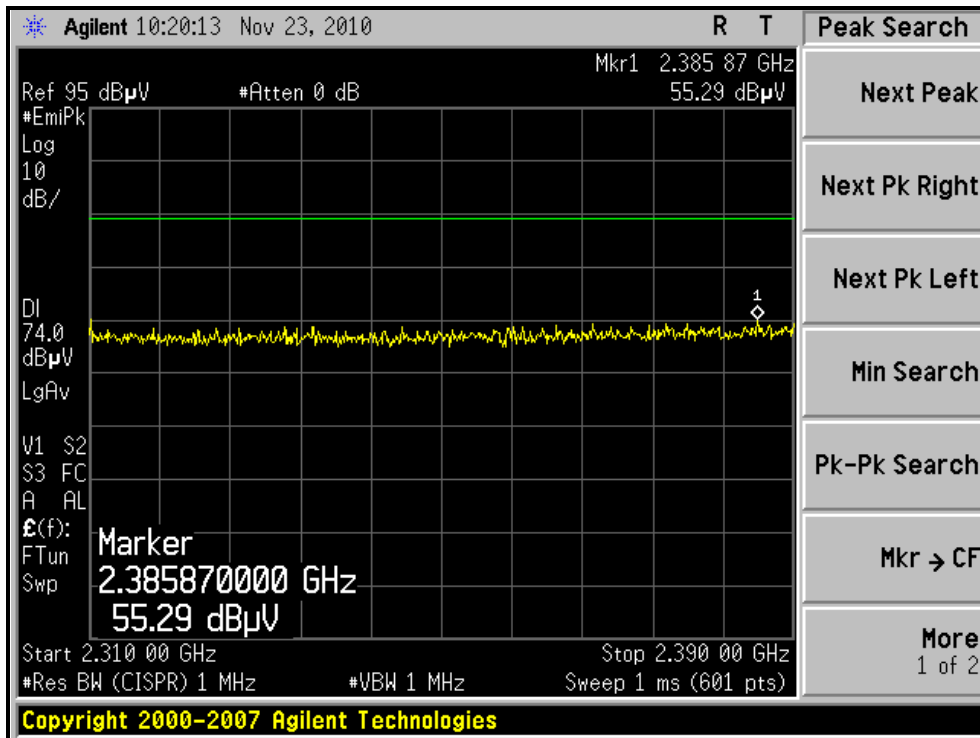



A D T

RESTRICTED BANDEDGE (802.11g MODE, CH1, VERTICAL)

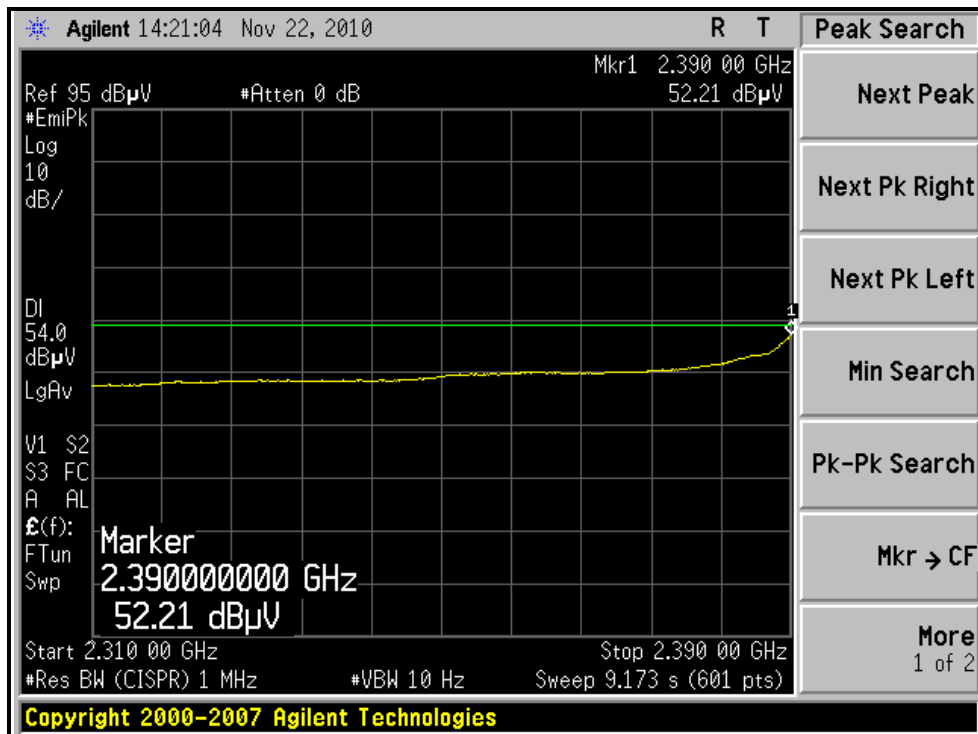
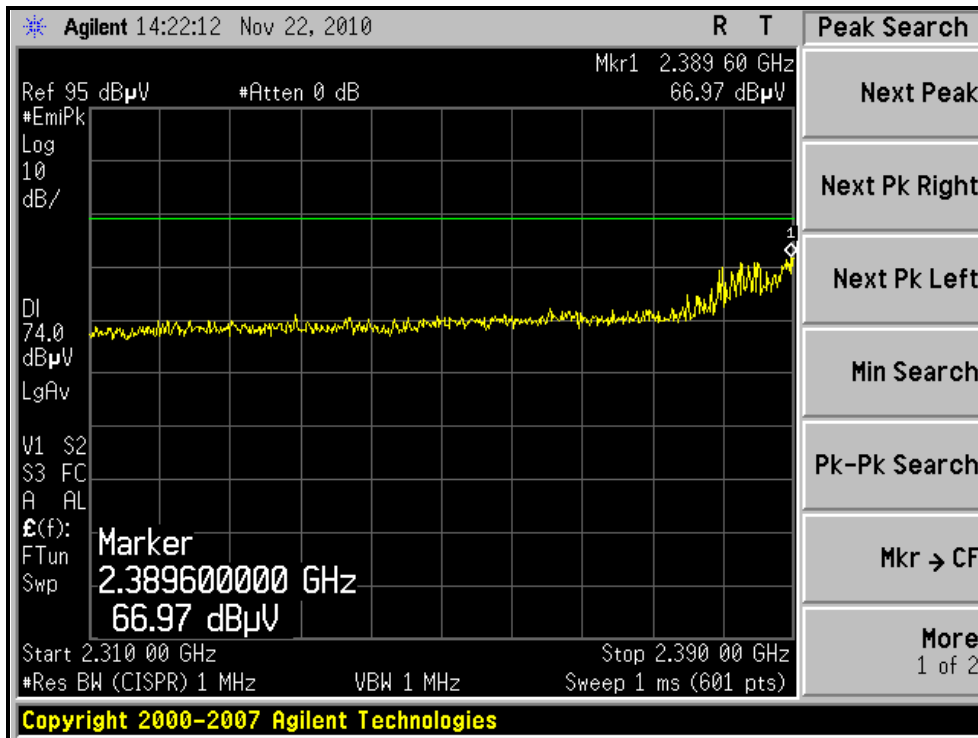



A D T

RESTRICTED BANDEDGE (802.11g MODE,CH11, HORIZONTAL)

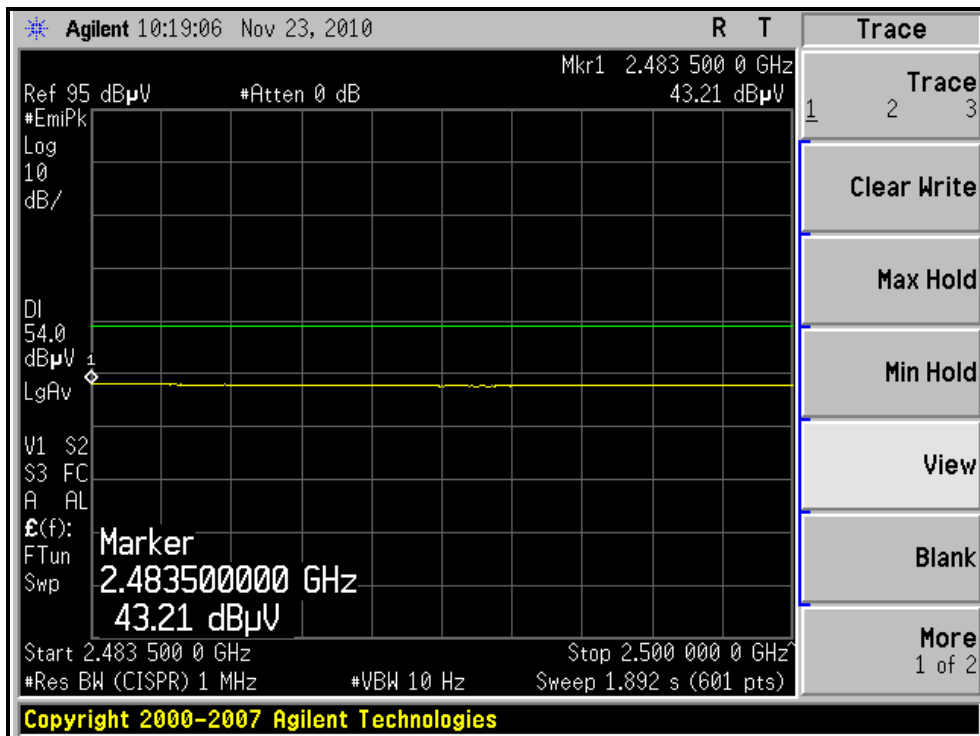
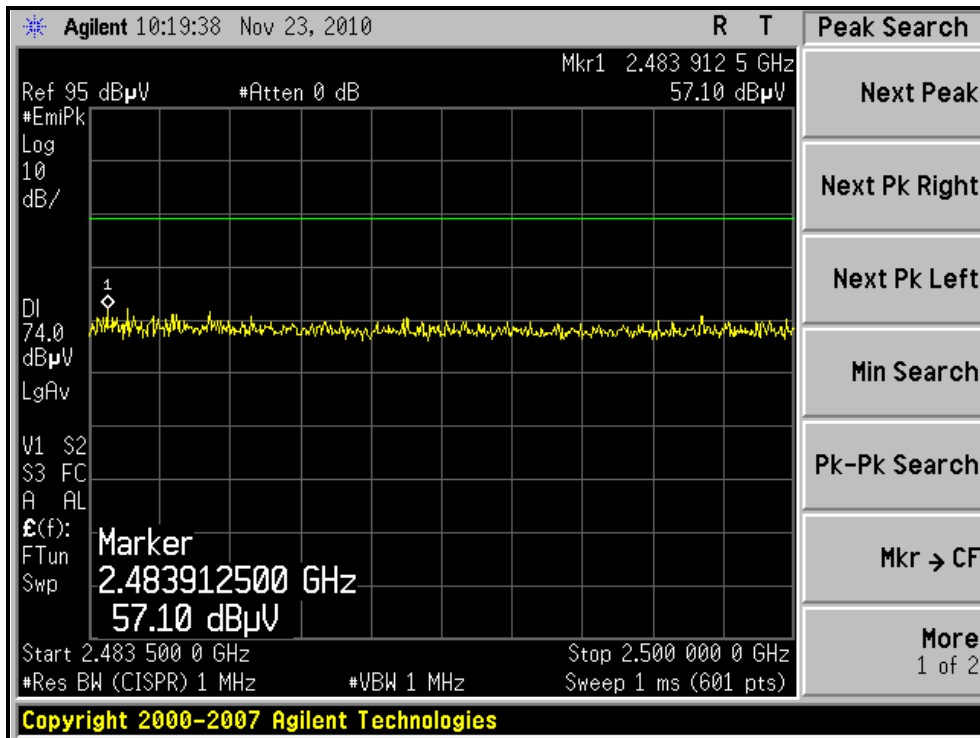



A D T

RESTRICTED BANDEDGE (802.11g MODE, CH11, VERTICAL)

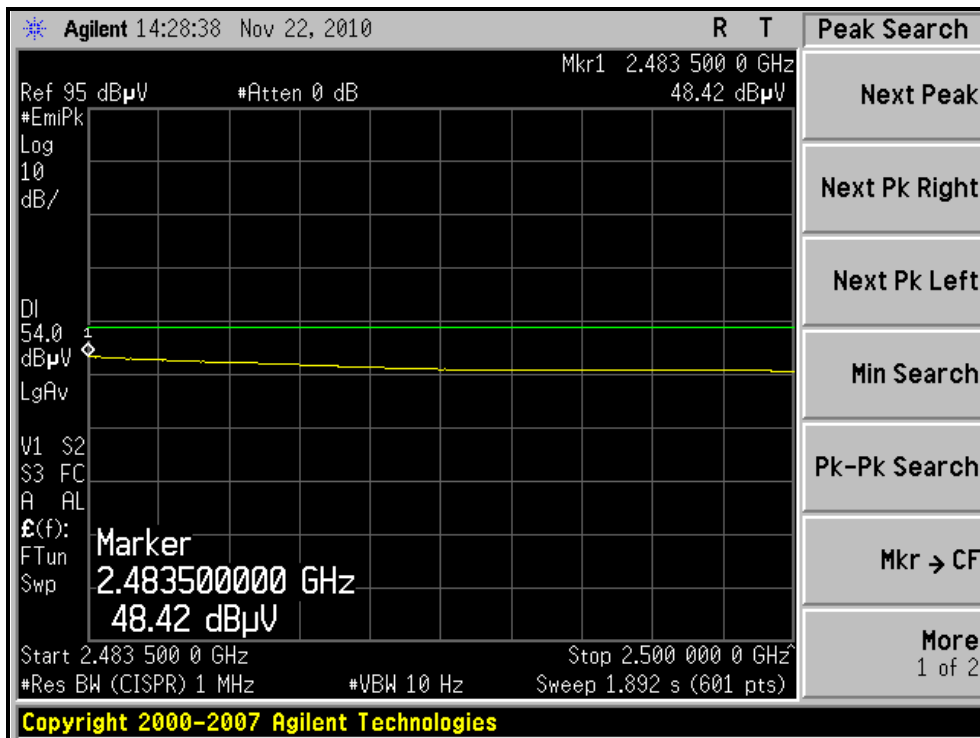
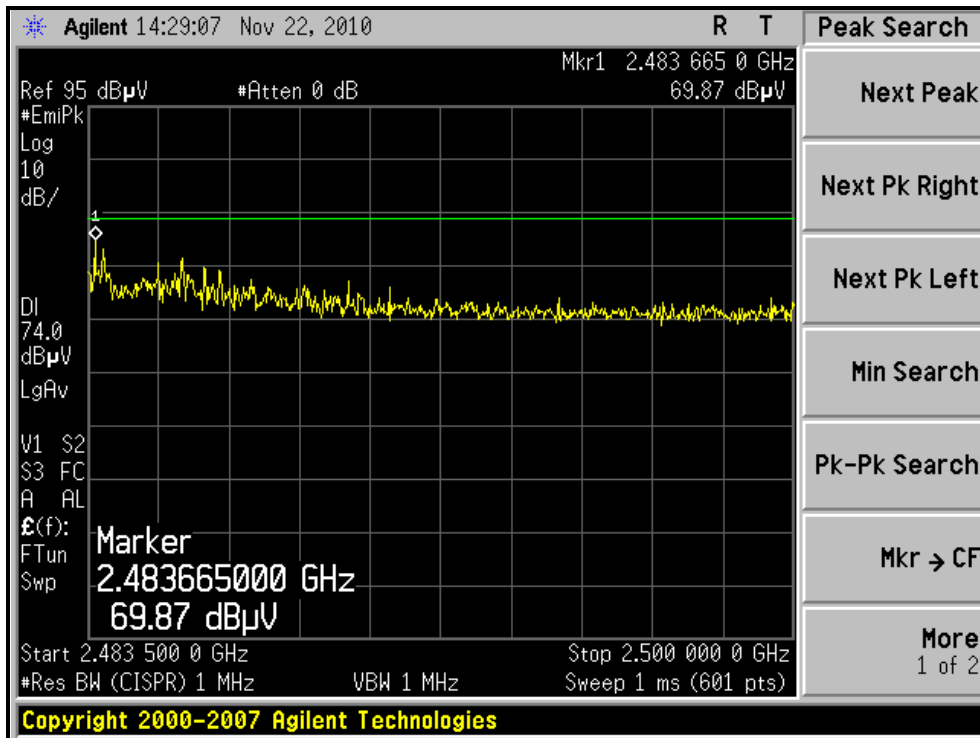



A D T

802.11n (20MHz) OFDM MODULATION

EUT TEST CONDITION		MEASUREMENT DETAIL	
CHANNEL	Channel 1	FREQUENCY RANGE	1 ~ 25GHz
INPUT POWER	120Vac, 60 Hz	DETECTOR FUNCTION	Peak (PK) Average (AV)
ENVIRONMENTAL CONDITIONS	25deg. C, 67%RH 1013 hPa	TESTED BY	Frank Liu

ANTENNA POLARITY & TEST DISTANCE: HORIZONTAL AT 3 M								
NO.	FREQ. (MHz)	EMISSION LEVEL (dBuV/m)	LIMIT (dBuV/m)	MARGIN (dB)	ANTENNA HEIGHT (m)	TABLE ANGLE (Degree)	RAW VALUE (dBuV)	CORRECTION FACTOR (dB/m)
1	2390.00	55.4 PK	74.0	-18.6	1.28 H	290	24.40	31.00
2	2390.00	43.6 AV	54.0	-10.4	1.28 H	290	12.60	31.00
3	*2412.00	94.7 PK			1.24 H	279	63.60	31.10
4	*2412.00	86.4 AV			1.24 H	279	55.30	31.10
5	4824.00	43.5 PK	74.0	-30.5	1.00 H	173	6.40	37.10
6	4824.00	34.3 AV	54.0	-19.7	1.00 H	173	-2.80	37.10
ANTENNA POLARITY & TEST DISTANCE: VERTICAL AT 3 M								
NO.	FREQ. (MHz)	EMISSION LEVEL (dBuV/m)	LIMIT (dBuV/m)	MARGIN (dB)	ANTENNA HEIGHT (m)	TABLE ANGLE (Degree)	RAW VALUE (dBuV)	CORRECTION FACTOR (dB/m)
1	2390.00	69.3 PK	74.0	-4.7	1.13 V	111	38.30	31.00
2	2390.00	53.4 AV	54.0	-0.6	1.13 V	111	22.40	31.00
3	*2412.00	108.6 PK			1.00 V	137	77.50	31.10
4	*2412.00	99.0 AV			1.00 V	137	67.90	31.10
5	4824.00	45.3 PK	74.0	-28.7	1.52 V	66	8.20	37.10
6	4824.00	37.1 AV	54.0	-16.9	1.52 V	66	0.00	37.10

- REMARKS:**
1. Emission level (dBuV/m) = Raw Value (dBuV) + Correction Factor (dB/m).
 2. Correction Factor (dB/m) = Antenna Factor (dB/m) + Cable Factor (dB).
 3. The other emission levels were very low against the limit.
 4. Margin value = Emission level – Limit value.
 5. “ * “: Fundamental frequency.



A D T

EUT TEST CONDITION		MEASUREMENT DETAIL	
CHANNEL	Channel 6	FREQUENCY RANGE	1 ~ 25GHz
INPUT POWER	120Vac, 60 Hz	DETECTOR FUNCTION	Peak (PK) Average (AV)
ENVIRONMENTAL CONDITIONS	25deg. C, 67%RH 1013 hPa	TESTED BY	Frank Liu

ANTENNA POLARITY & TEST DISTANCE: HORIZONTAL AT 3 M								
NO.	FREQ. (MHz)	EMISSION LEVEL (dBuV/m)	LIMIT (dBuV/m)	MARGIN (dB)	ANTENNA HEIGHT (m)	TABLE ANGLE (Degree)	RAW VALUE (dBuV)	CORRECTION FACTOR (dB/m)
1	*2437.00	98.2 PK			1.24 H	273	67.00	31.20
2	*2437.00	88.4 AV			1.24 H	273	57.20	31.20
3	4874.00	44.5 PK	74.0	-29.5	1.00 H	193	7.30	37.20
4	4874.00	35.7 AV	54.0	-18.3	1.00 H	193	-1.50	37.20
5	7311.00	50.6 PK	74.0	-23.4	1.32 H	157	6.20	44.40
6	7311.00	38.4 AV	54.0	-15.6	1.32 H	157	-6.00	44.40
ANTENNA POLARITY & TEST DISTANCE: VERTICAL AT 3 M								
NO.	FREQ. (MHz)	EMISSION LEVEL (dBuV/m)	LIMIT (dBuV/m)	MARGIN (dB)	ANTENNA HEIGHT (m)	TABLE ANGLE (Degree)	RAW VALUE (dBuV)	CORRECTION FACTOR (dB/m)
1	*2437.00	110.2 PK			1.00 V	136	79.00	31.20
2	*2437.00	101.4 AV			1.00 V	136	70.20	31.20
3	4874.00	46.2 PK	74.0	-27.8	1.51 V	74	9.00	37.20
4	4874.00	39.3 AV	54.0	-14.7	1.51 V	74	2.10	37.20
5	7311.00	61.3 PK	74.0	-12.7	1.52 V	181	16.90	44.40
6	7311.00	51.4 AV	54.0	-2.6	1.52 V	181	7.00	44.40

- REMARKS:**
1. Emission level (dBuV/m) = Raw Value (dBuV) + Correction Factor (dB/m).
 2. Correction Factor (dB/m) = Antenna Factor (dB/m) + Cable Factor (dB).
 3. The other emission levels were very low against the limit.
 4. Margin value = Emission level – Limit value.
 5. “ * “: Fundamental frequency.



A D T

EUT TEST CONDITION		MEASUREMENT DETAIL	
CHANNEL	Channel 11	FREQUENCY RANGE	1 ~ 25GHz
INPUT POWER	120Vac, 60 Hz	DETECTOR FUNCTION	Peak (PK) Average (AV)
ENVIRONMENTAL CONDITIONS	25deg. C, 67%RH 1013 hPa	TESTED BY	Frank Liu

ANTENNA POLARITY & TEST DISTANCE: HORIZONTAL AT 3 M								
NO.	FREQ. (MHz)	EMISSION LEVEL (dBuV/m)	LIMIT (dBuV/m)	MARGIN (dB)	ANTENNA HEIGHT (m)	TABLE ANGLE (Degree)	RAW VALUE (dBuV)	CORRECTION FACTOR (dB/m)
1	*2462.00	96.4 PK			1.27 H	284	65.10	31.30
2	*2462.00	86.3 AV			1.27 H	284	55.00	31.30
3	2483.77	59.7 PK	74.0	-14.3	1.28 H	290	28.30	31.40
4	2483.77	44.0 AV	54.0	-10.0	1.28 H	290	12.60	31.40
5	4924.00	43.2 PK	74.0	-30.8	1.00 H	187	5.90	37.30
6	4924.00	34.4 AV	54.0	-19.6	1.00 H	187	-2.90	37.30
7	7386.00	50.3 PK	74.0	-23.7	1.34 H	151	5.70	44.60
8	7386.00	38.4 AV	54.0	-15.6	1.34 H	151	-6.20	44.60
ANTENNA POLARITY & TEST DISTANCE: VERTICAL AT 3 M								
NO.	FREQ. (MHz)	EMISSION LEVEL (dBuV/m)	LIMIT (dBuV/m)	MARGIN (dB)	ANTENNA HEIGHT (m)	TABLE ANGLE (Degree)	RAW VALUE (dBuV)	CORRECTION FACTOR (dB/m)
1	*2462.00	108.4 PK			1.00 V	277	77.10	31.30
2	*2462.00	99.2 AV			1.00 V	277	67.90	31.30
3	2483.50	70.4 PK	74.0	-3.6	1.00 V	277	39.00	31.40
4	2483.50	50.1 AV	54.0	-3.9	1.00 V	277	18.70	31.40
5	4924.00	45.3 PK	74.0	-28.7	1.00 V	126	8.00	37.30
6	4924.00	37.2 AV	54.0	-16.8	1.00 V	126	-0.10	37.30
7	7386.00	56.1 PK	74.0	-17.9	1.13 V	324	11.50	44.60
8	7386.00	41.3 AV	54.0	-12.7	1.13 V	324	-3.30	44.60

- REMARKS:**
1. Emission level (dBuV/m) = Raw Value (dBuV) + Correction Factor (dB/m).
 2. Correction Factor (dB/m) = Antenna Factor (dB/m) + Cable Factor (dB).
 3. The other emission levels were very low against the limit.
 4. Margin value = Emission level – Limit value.
 5. “ * “: Fundamental frequency.



A D T

RESTRICTED BANDEDGE (802.11n (20MHz) MODE,CH1, HORIZONTAL)

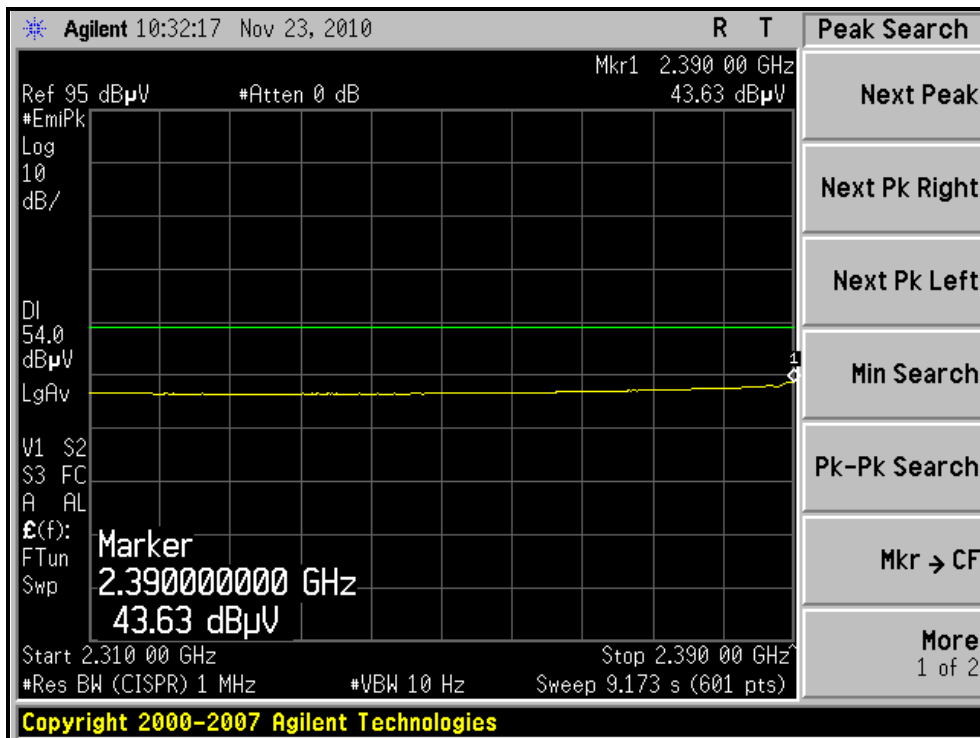
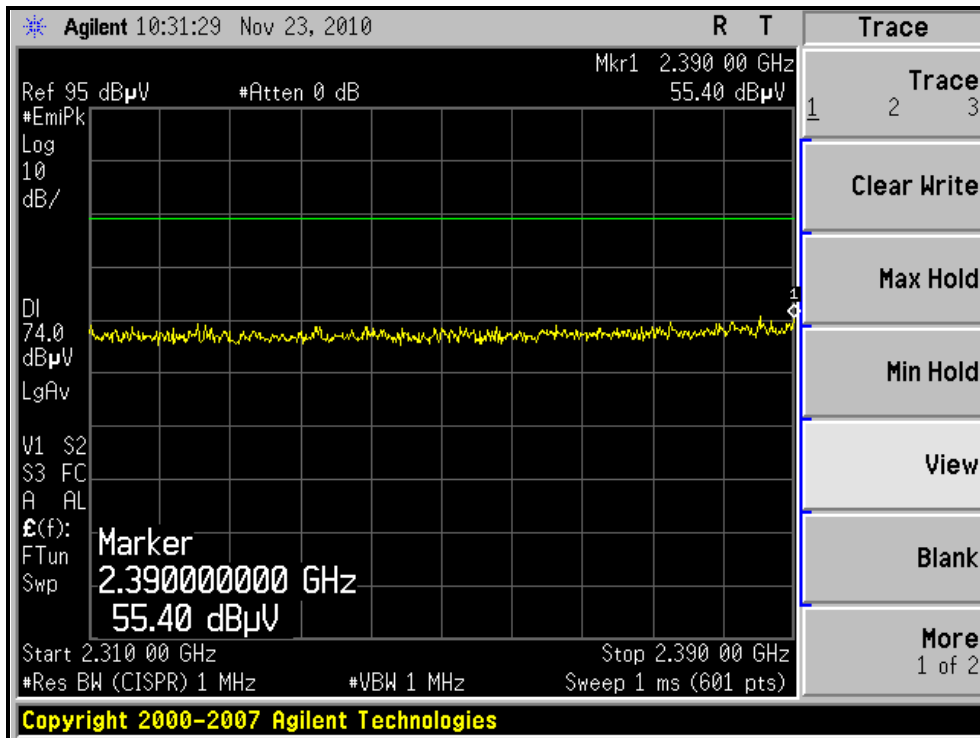



A D T

RESTRICTED BANDEDGE (802.11n (20MHz) MODE,CH1, VERTICAL)

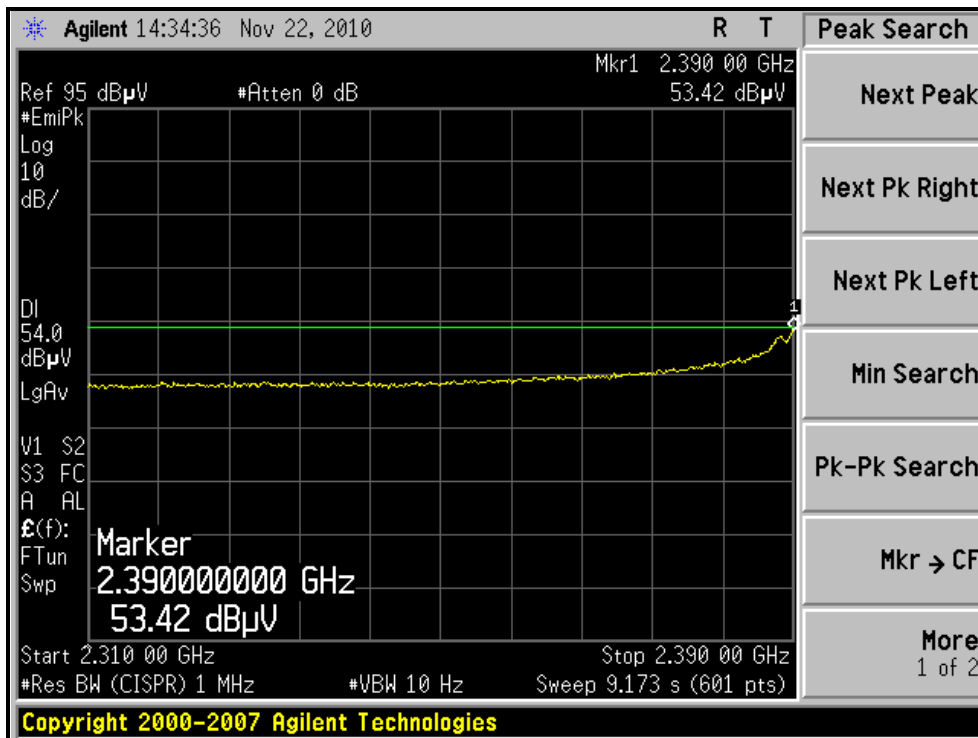
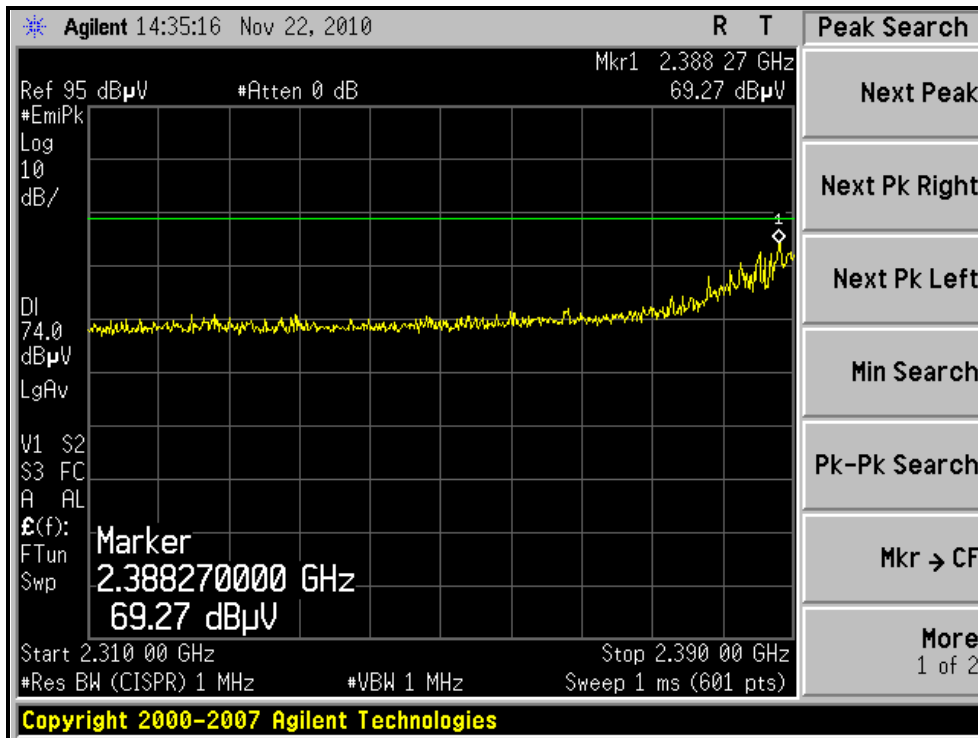



A D T

RESTRICTED BANDEDGE (802.11n (20MHz) MODE, CH11, HORIZONTAL)

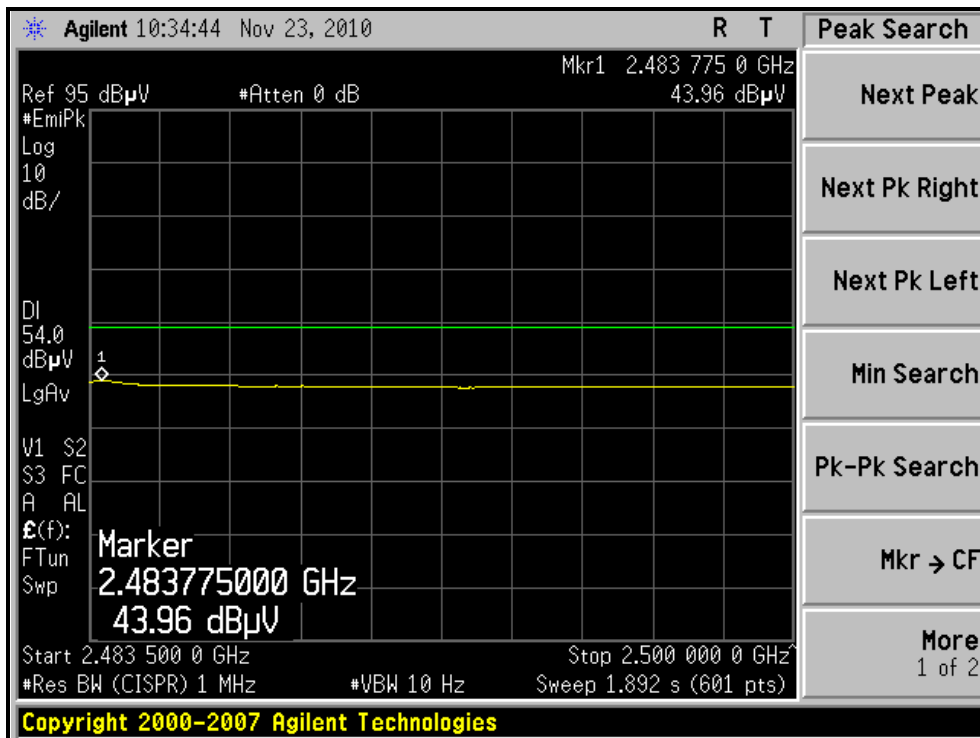
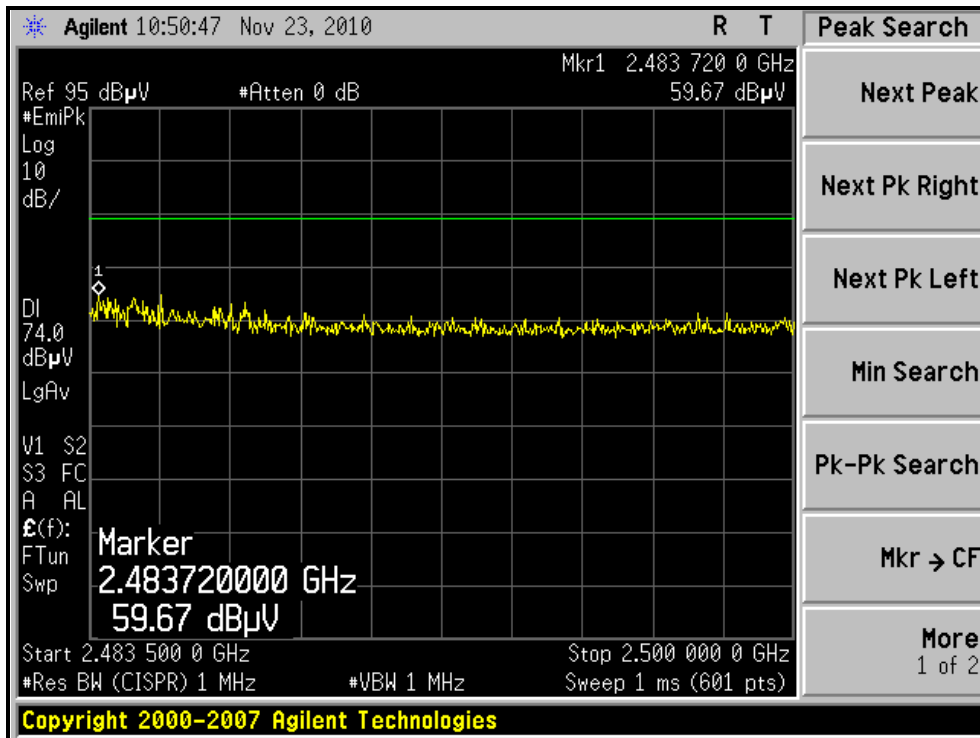



A D T

RESTRICTED BANDEDGE (802.11n (20MHz) MODE,CH11, VERTICAL)

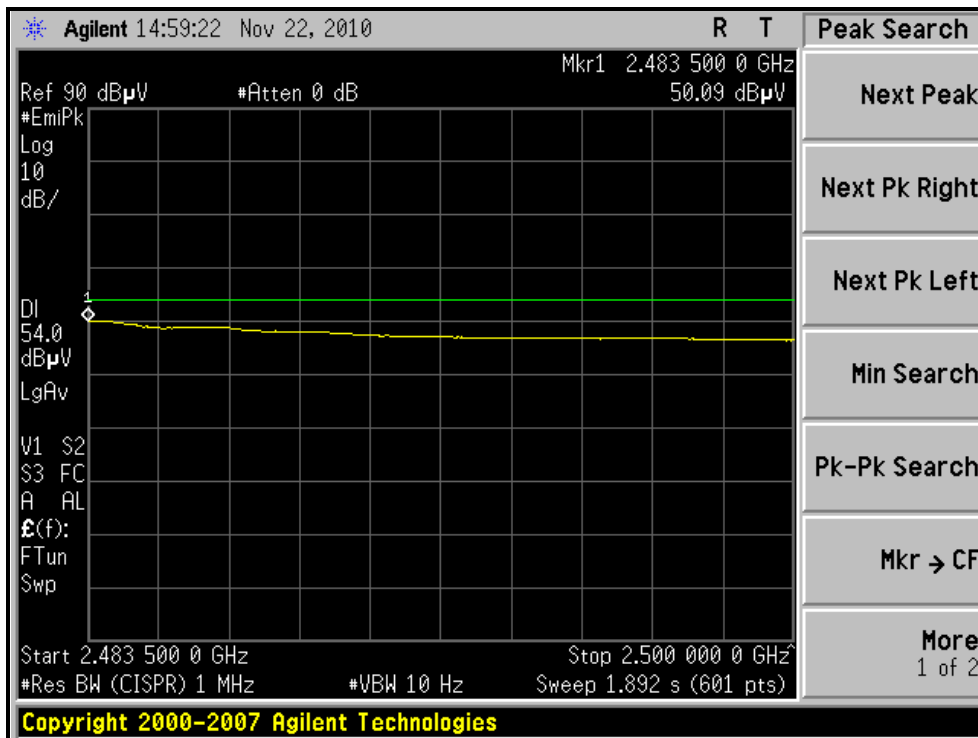
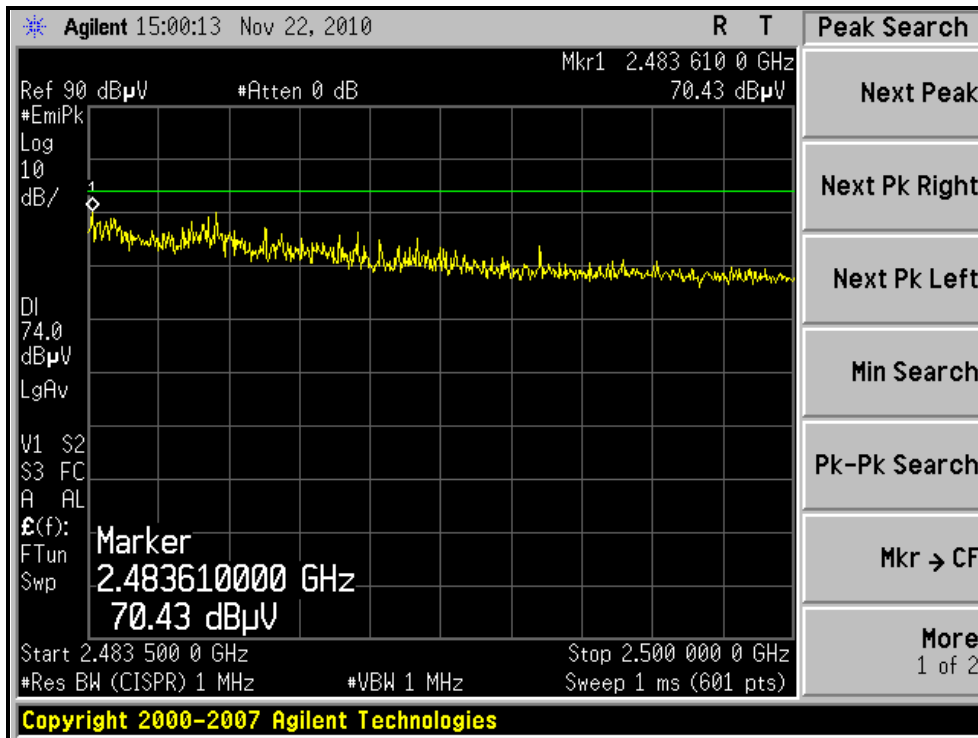



A D T

802.11n (40MHz) OFDM MODULATION

EUT TEST CONDITION		MEASUREMENT DETAIL	
CHANNEL	Channel 1	FREQUENCY RANGE	1 ~ 25GHz
INPUT POWER	120Vac, 60 Hz	DETECTOR FUNCTION	Peak (PK) Average (AV)
ENVIRONMENTAL CONDITIONS	25deg. C, 67%RH 1013 hPa	TESTED BY	Frank Liu

ANTENNA POLARITY & TEST DISTANCE: HORIZONTAL AT 3 M								
NO.	FREQ. (MHz)	EMISSION LEVEL (dBuV/m)	LIMIT (dBuV/m)	MARGIN (dB)	ANTENNA HEIGHT (m)	TABLE ANGLE (Degree)	RAW VALUE (dBuV)	CORRECTION FACTOR (dB/m)
1	2389.47	59.6 PK	74.0	-14.4	1.28 H	303	28.60	31.00
2	2389.47	46.7 AV	54.0	-7.3	1.28 H	303	15.70	31.00
3	*2422.00	93.1 PK			1.21 H	283	62.00	31.10
4	*2422.00	80.4 AV			1.21 H	283	49.30	31.10
5	4844.00	42.7 PK	74.0	-31.3	1.00 H	163	5.50	37.20
6	4844.00	34.2 AV	54.0	-19.8	1.00 H	163	-3.00	37.20
7	7266.00	50.9 PK	74.0	-23.1	1.31 H	154	6.70	44.20
8	7266.00	38.7 AV	54.0	-15.3	1.31 H	154	-5.50	44.20
ANTENNA POLARITY & TEST DISTANCE: VERTICAL AT 3 M								
NO.	FREQ. (MHz)	EMISSION LEVEL (dBuV/m)	LIMIT (dBuV/m)	MARGIN (dB)	ANTENNA HEIGHT (m)	TABLE ANGLE (Degree)	RAW VALUE (dBuV)	CORRECTION FACTOR (dB/m)
1	2390.00	65.7 PK	74.0	-8.3	1.13 V	111	34.70	31.00
2	2390.00	53.2 AV	54.0	-0.8	1.13 V	111	22.20	31.00
3	*2422.00	105.2 PK			1.00 V	284	74.10	31.10
4	*2422.00	93.2 AV			1.00 V	284	62.10	31.10
5	4844.00	47.1 PK	74.0	-26.9	1.00 V	300	9.90	37.20
6	4844.00	39.2 AV	54.0	-14.8	1.00 V	300	2.00	37.20
7	7266.00	55.4 PK	74.0	-18.6	1.04 V	243	11.20	44.20
8	7266.00	40.3 AV	54.0	-13.7	1.04 V	243	-3.90	44.20

- REMARKS:**
1. Emission level (dBuV/m) = Raw Value (dBuV) + Correction Factor (dB/m).
 2. Correction Factor (dB/m) = Antenna Factor (dB/m) + Cable Factor (dB).
 3. The other emission levels were very low against the limit.
 4. Margin value = Emission level – Limit value.
 5. “ * “: Fundamental frequency.



A D T

EUT TEST CONDITION		MEASUREMENT DETAIL	
CHANNEL	Channel 4	FREQUENCY RANGE	1 ~ 25GHz
INPUT POWER	120Vac, 60 Hz	DETECTOR FUNCTION	Peak (PK) Average (AV)
ENVIRONMENTAL CONDITIONS	25deg. C, 67%RH 1013 hPa	TESTED BY	Frank Liu

ANTENNA POLARITY & TEST DISTANCE: HORIZONTAL AT 3 M

NO.	FREQ. (MHz)	EMISSION LEVEL (dBuV/m)	LIMIT (dBuV/m)	MARGIN (dB)	ANTENNA HEIGHT (m)	TABLE ANGLE (Degree)	RAW VALUE (dBuV)	CORRECTION FACTOR (dB/m)
1	*2437.00	96.7 PK			1.26 H	279	65.53	31.17
2	*2437.00	83.1 AV			1.26 H	279	51.93	31.17
3	4874.00	42.1 PK	74.0	-31.9	1.00 H	159	4.87	37.23
4	4874.00	34.1 AV	54.0	-19.9	1.00 H	159	-3.13	37.23
5	7311.00	51.3 PK	74.0	-22.7	1.34 H	156	6.94	44.36
6	7311.00	38.9 AV	54.0	-15.1	1.34 H	156	-5.46	44.36

ANTENNA POLARITY & TEST DISTANCE: VERTICAL AT 3 M

NO.	FREQ. (MHz)	EMISSION LEVEL (dBuV/m)	LIMIT (dBuV/m)	MARGIN (dB)	ANTENNA HEIGHT (m)	TABLE ANGLE (Degree)	RAW VALUE (dBuV)	CORRECTION FACTOR (dB/m)
1	2390.00	64.7 PK	74.0	-9.3	1.07 V	276	33.73	30.97
2	2390.00	51.9 AV	54.0	-2.1	1.07 V	276	20.93	30.97
3	*2437.00	108.9 PK			1.00 V	327	77.73	31.17
4	*2437.00	96.4 AV			1.00 V	327	65.23	31.17
5	4874.00	47.3 PK	74.0	-26.7	1.00 V	124	10.07	37.23
6	4874.00	39.4 AV	54.0	-14.6	1.00 V	124	2.17	37.23
7	7311.00	58.2 PK	74.0	-15.8	1.00 V	16	13.84	44.36
8	7311.00	46.3 AV	54.0	-7.7	1.00 V	16	1.94	44.36

- REMARKS:**
1. Emission level (dBuV/m) = Raw Value (dBuV) + Correction Factor (dB/m).
 2. Correction Factor (dB/m) = Antenna Factor (dB/m) + Cable Factor (dB).
 3. The other emission levels were very low against the limit.
 4. Margin value = Emission level – Limit value.
 5. “ * “: Fundamental frequency.



A D T

EUT TEST CONDITION		MEASUREMENT DETAIL	
CHANNEL	Channel 7	FREQUENCY RANGE	1 ~ 25GHz
INPUT POWER	120Vac, 60 Hz	DETECTOR FUNCTION	Peak (PK) Average (AV)
ENVIRONMENTAL CONDITIONS	25deg. C, 67%RH 1013 hPa	TESTED BY	Frank Liu

ANTENNA POLARITY & TEST DISTANCE: HORIZONTAL AT 3 M								
NO.	FREQ. (MHz)	EMISSION LEVEL (dBuV/m)	LIMIT (dBuV/m)	MARGIN (dB)	ANTENNA HEIGHT (m)	TABLE ANGLE (Degree)	RAW VALUE (dBuV)	CORRECTION FACTOR (dB/m)
1	*2452.00	93.7 PK			1.24 H	287	62.50	31.20
2	*2452.00	81.3 AV			1.24 H	287	50.10	31.20
3	2483.50	56.9 PK	74.0	-17.1	1.36 H	261	25.50	31.40
4	2483.50	44.6 AV	54.0	-9.4	1.36 H	261	13.20	31.40
5	4904.00	42.8 PK	74.0	-31.2	1.00 H	169	5.50	37.30
6	4904.00	33.1 AV	54.0	-20.9	1.00 H	169	-4.20	37.30
7	7356.00	50.7 PK	74.0	-23.3	1.27 H	155	6.20	44.50
8	7356.00	38.1 AV	54.0	-15.9	1.27 H	155	-6.40	44.50
ANTENNA POLARITY & TEST DISTANCE: VERTICAL AT 3 M								
NO.	FREQ. (MHz)	EMISSION LEVEL (dBuV/m)	LIMIT (dBuV/m)	MARGIN (dB)	ANTENNA HEIGHT (m)	TABLE ANGLE (Degree)	RAW VALUE (dBuV)	CORRECTION FACTOR (dB/m)
1	*2452.00	106.7 PK			1.00 V	300	75.50	31.20
2	*2452.00	94.7 AV			1.00 V	300	63.50	31.20
3	2483.50	61.9 PK	74.0	-12.1	1.00 V	112	30.50	31.40
4	2483.50	48.2 AV	54.0	-5.8	1.00 V	112	16.80	31.40
5	4904.00	44.2 PK	74.0	-29.8	1.00 V	121	6.90	37.30
6	4904.00	36.3 AV	54.0	-17.7	1.00 V	121	-1.00	37.30
7	7356.00	55.9 PK	74.0	-18.1	1.14 V	311	11.40	44.50
8	7356.00	39.3 AV	54.0	-14.7	1.14 V	311	-5.20	44.50

- REMARKS:**
1. Emission level (dBuV/m) = Raw Value (dBuV) + Correction Factor (dB/m).
 2. Correction Factor (dB/m) = Antenna Factor (dB/m) + Cable Factor (dB).
 3. The other emission levels were very low against the limit.
 4. Margin value = Emission level – Limit value.
 5. “ * “: Fundamental frequency.



A D T

RESTRICTED BANDEDGE (802.11n (40MHz) MODE,CH1, HORIZONTAL)

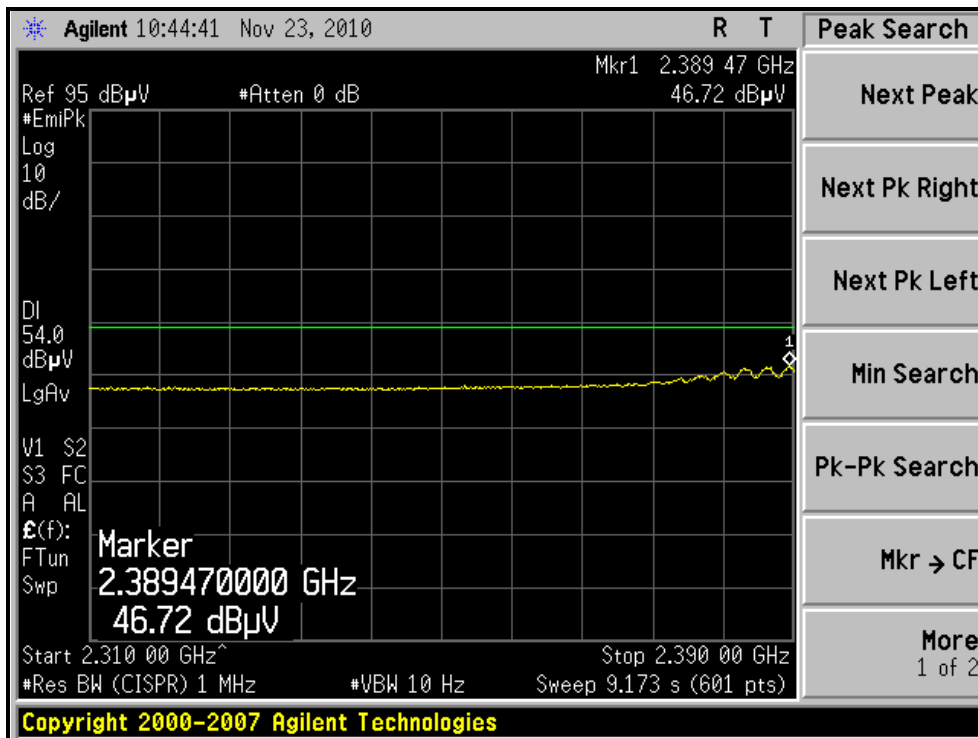
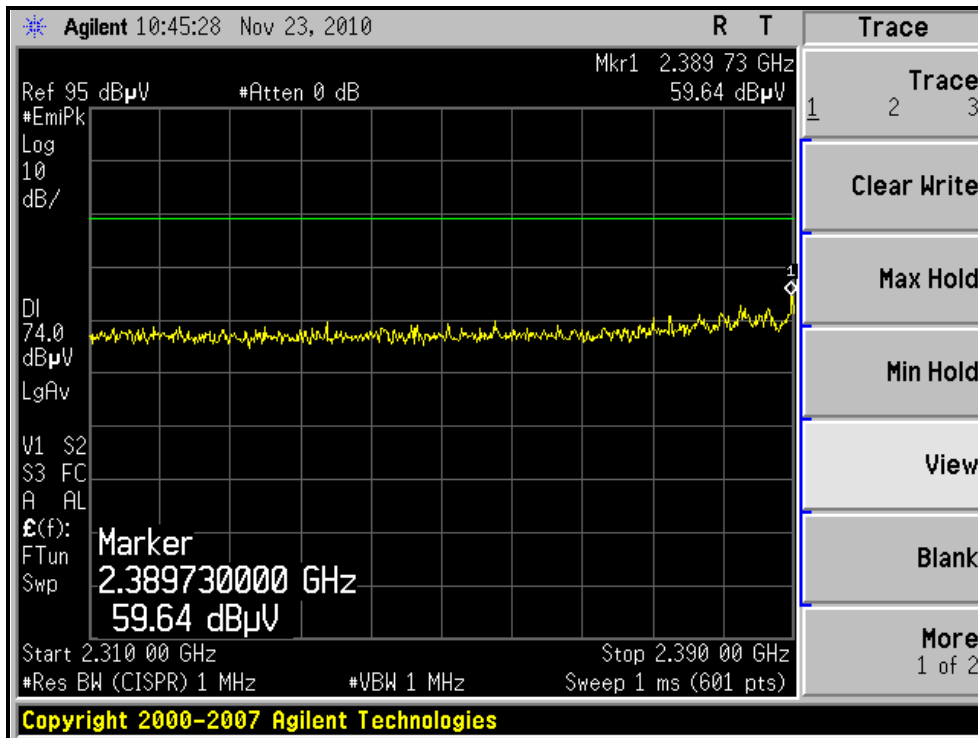



A D T

RESTRICTED BANDEDGE (802.11n (40MHz) MODE,CH1, VERTICAL)

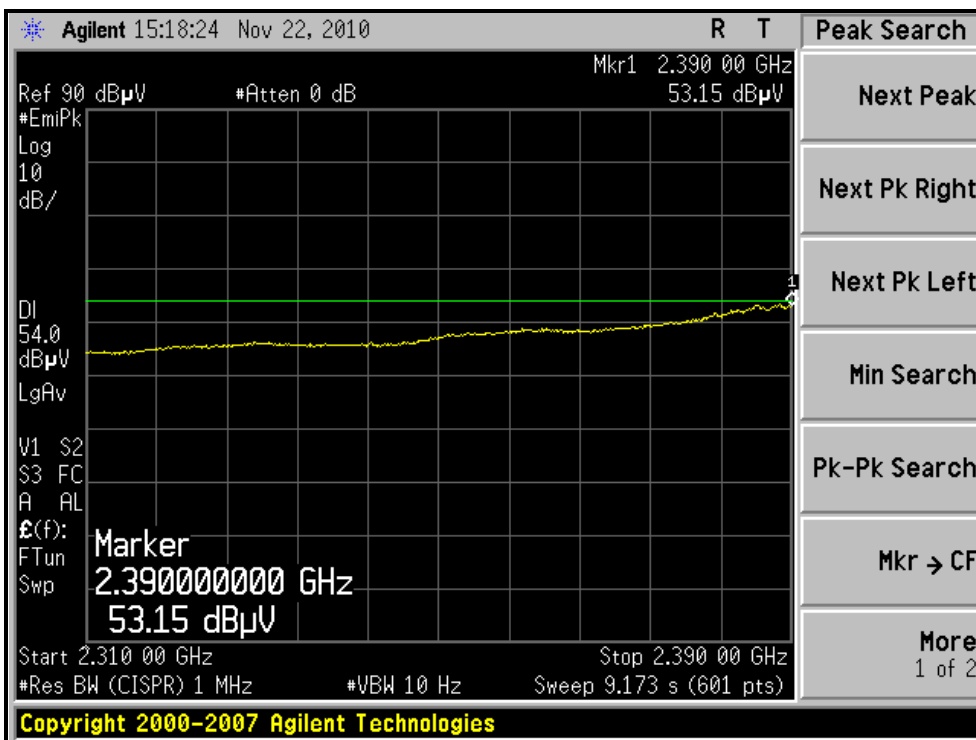
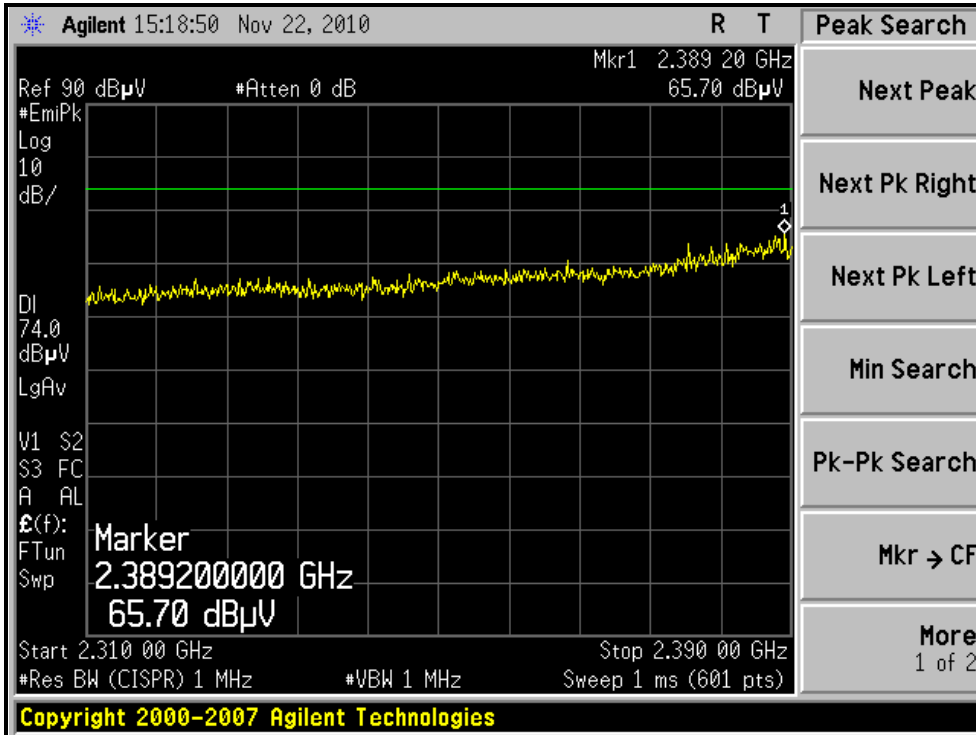



A D T

RESTRICTED BANDEDGE (802.11n (40MHz) MODE,CH7, HORIZONTAL)

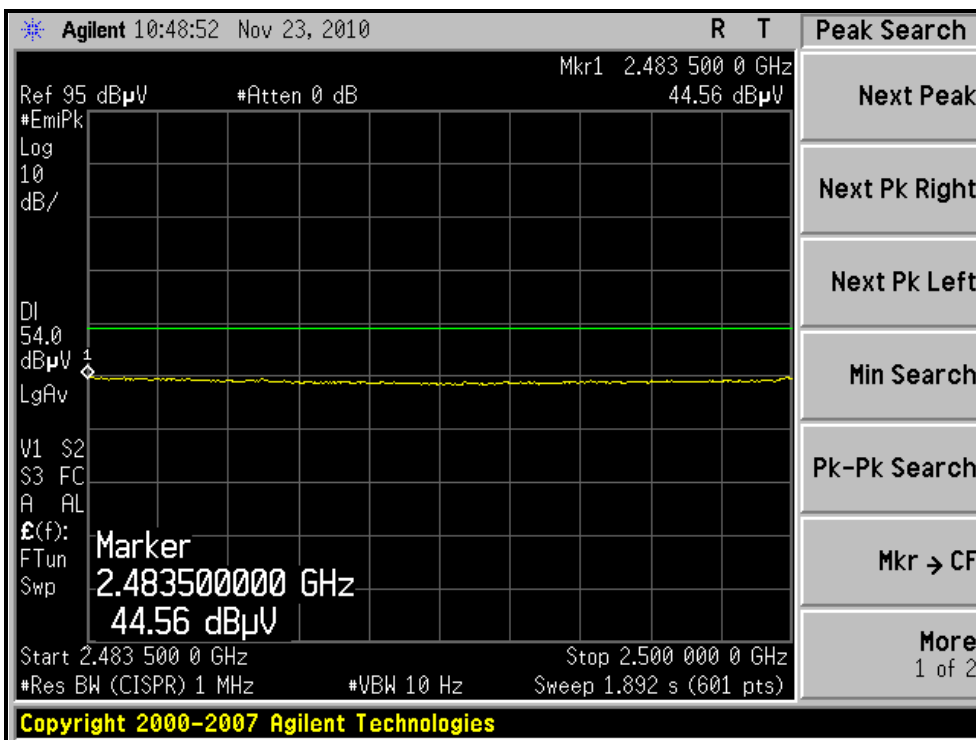
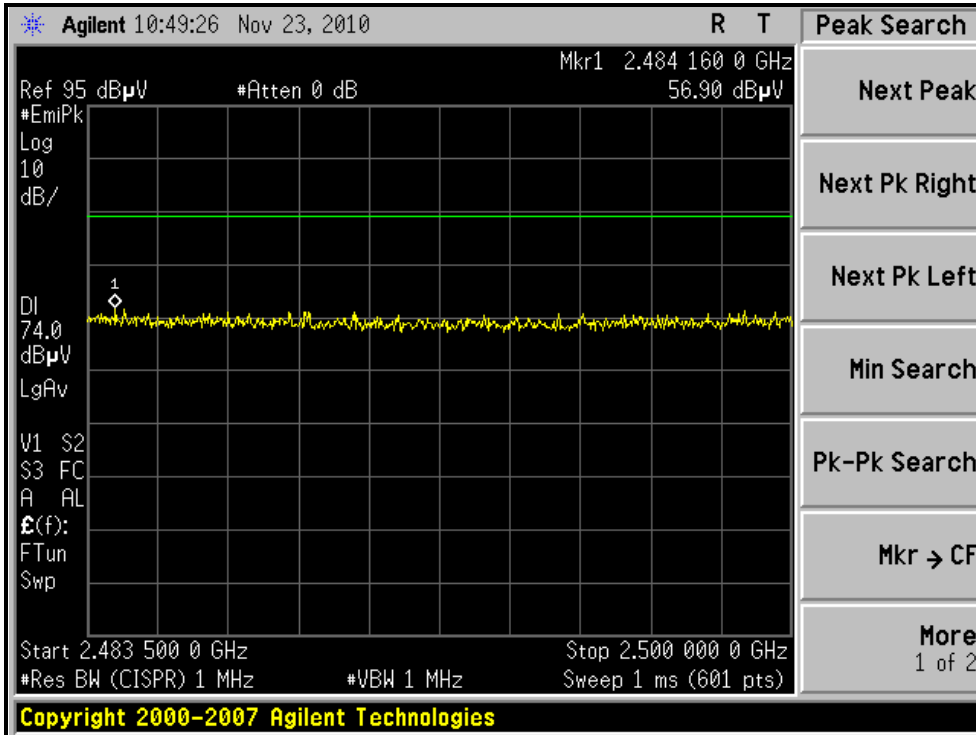



A D T

RESTRICTED BANDEDGE (802.11n (40MHz) MODE,CH7, VERTICAL)

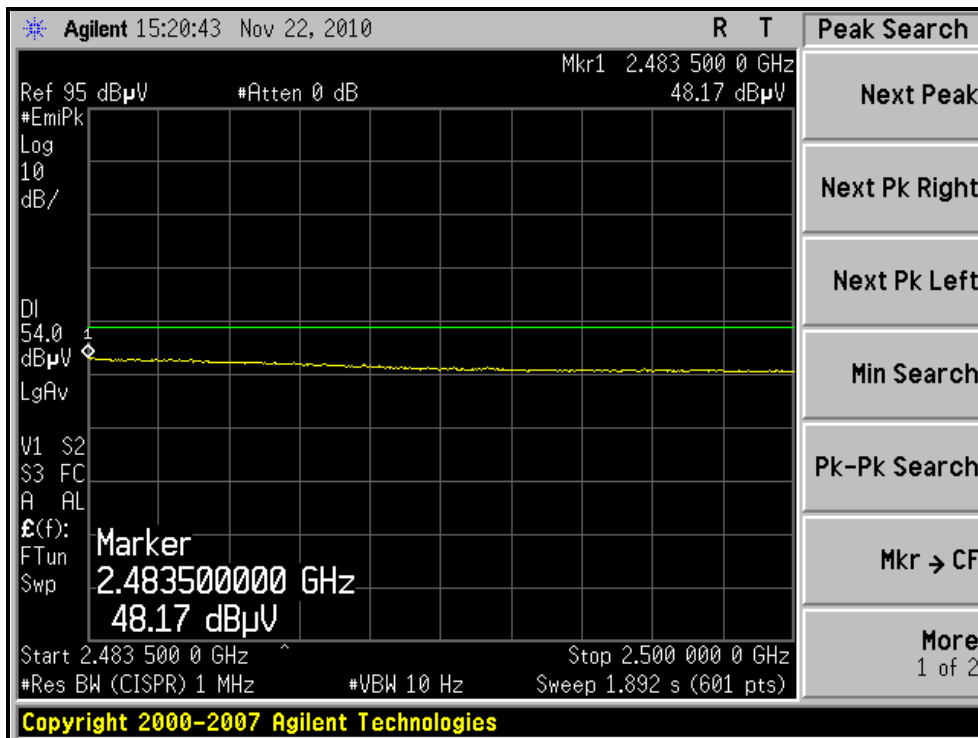
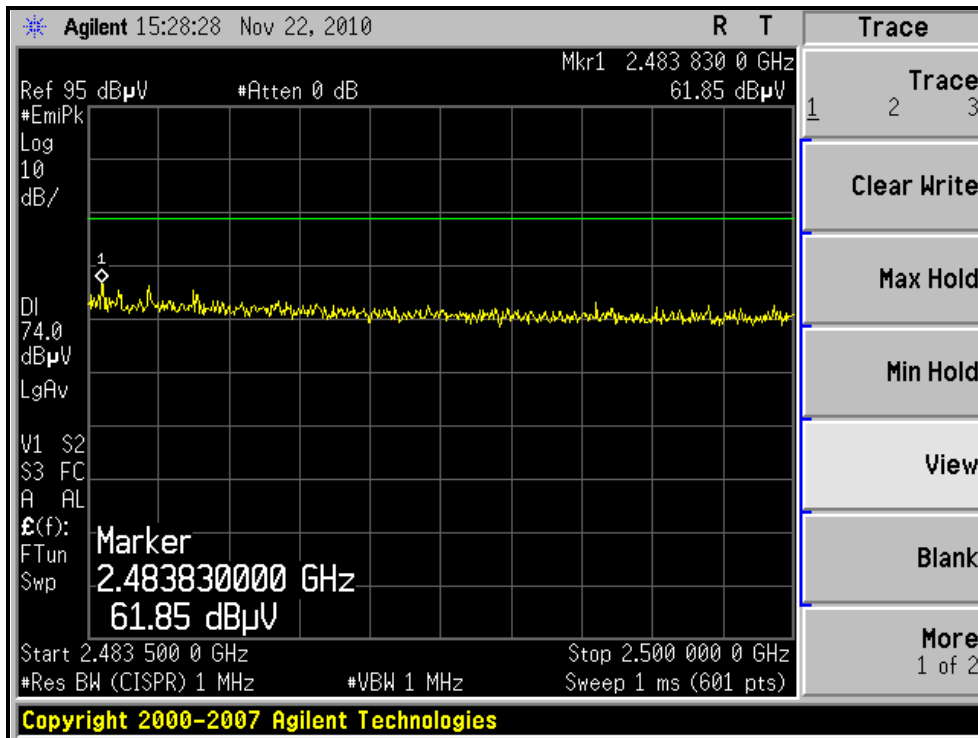

4.3 6dB BANDWIDTH MEASUREMENT

4.3.1 LIMITS OF 6dB BANDWIDTH MEASUREMENT

The minimum of 6dB Bandwidth Measurement is 0.5 MHz.

4.3.2 TEST INSTRUMENTS

DESCRIPTION & MANUFACTURER	MODEL NO.	SERIAL NO.	CALIBRATED DATE	CALIBRATED UNTIL
R&S SPECTRUM ANALYZER	E4446A	MY48250253	Aug. 02, 2010	Aug. 01, 2011

NOTE:

1. The calibration interval of the above test instruments is 12 months and the calibrations are traceable to NML/ROC and NIST/USA.

4.3.3 TEST PROCEDURE

The transmitter output was connected to the spectrum analyzer through an attenuator. The bandwidth of the fundamental frequency was measured by spectrum analyzer with 100kHz RBW and 100kHz VBW. The 6dB bandwidth is defined as the total spectrum the power of which is higher than peak power minus 6dB.

4.3.4 DEVIATION FROM TEST STANDARD

No deviation

4.3.5 TEST SETUP

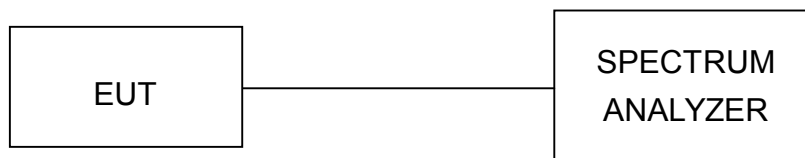

4.3.6 EUT OPERATING CONDITIONS

The software provided by client to enable the EUT under transmission condition continuously at lowest, middle and highest channel frequencies individually.



A D T

4.3.7 TEST RESULTS

802.11b DSSS MODULATION:

CHANNEL	CHANNEL FREQUENCY (MHz)	6dB BANDWIDTH (MHz)	MINIMUM LIMIT (MHz)	PASS / FAIL
1	2412	8.39	0.5	PASS
6	2437	8.07	0.5	PASS
11	2462	8.75	0.5	PASS

CH11

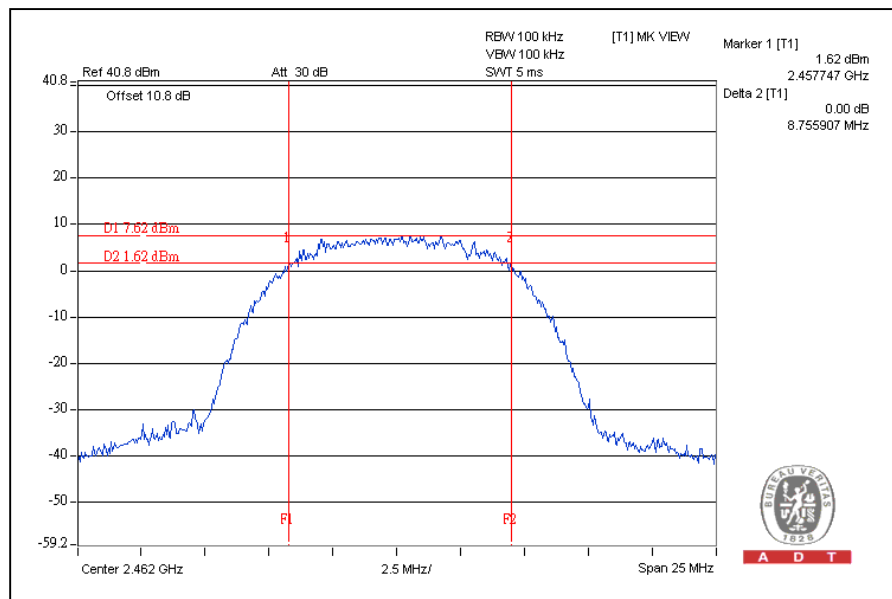



A D T

802.11g OFDM MODULATION:

CHANNEL	CHANNEL FREQUENCY (MHz)	6dB BANDWIDTH (MHz)	MINIMUM LIMIT (MHz)	PASS / FAIL
1	2412	16.42	0.5	PASS
6	2437	16.36	0.5	PASS
11	2462	16.38	0.5	PASS

CH1

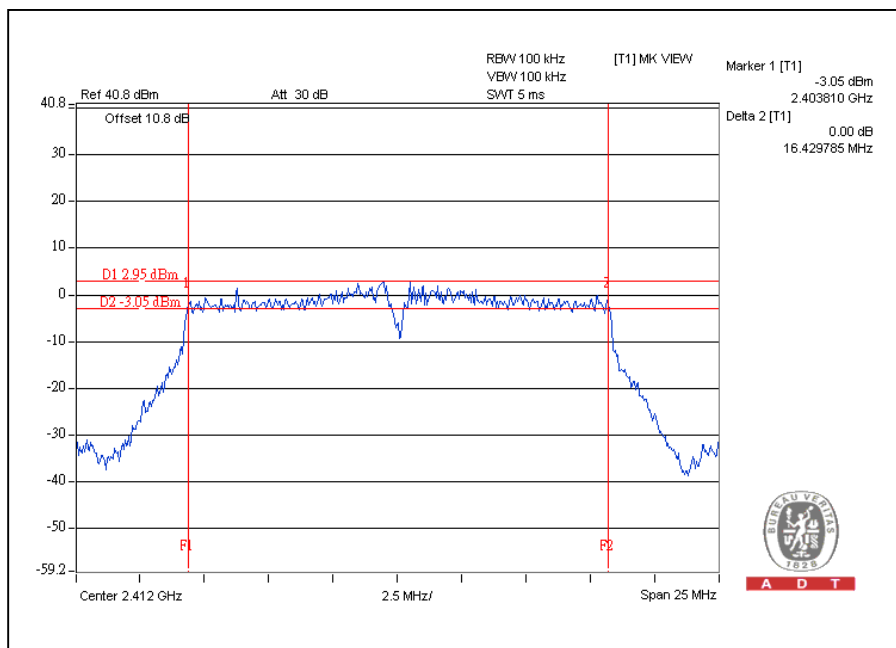



A D T

802.11n (20MHz) OFDM MODULATION:

CHANNEL	CHANNEL FREQUENCY (MHz)	6dB BANDWIDTH (MHz)	MINIMUM LIMIT (MHz)	PASS / FAIL
1	2412	17.62	0.5	PASS
6	2437	17.65	0.5	PASS
11	2462	17.73	0.5	PASS

CH11

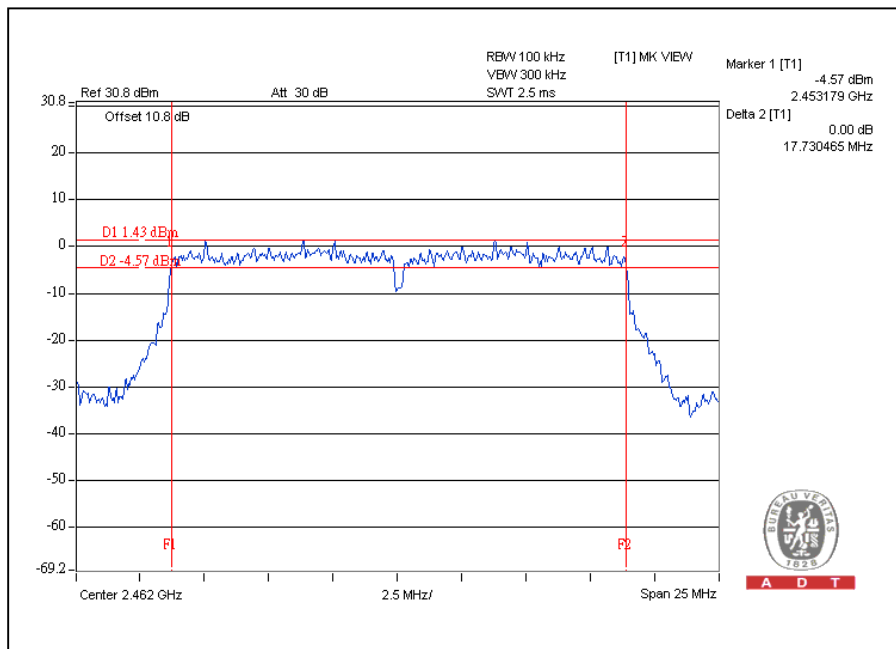



A D T

802.11n (40MHz) OFDM MODULATION:

CHANNEL	CHANNEL FREQUENCY (MHz)	6dB BANDWIDTH (MHz)	MINIMUM LIMIT (MHz)	PASS / FAIL
1	2422	35.24	0.5	PASS
4	2437	35.42	0.5	PASS
7	2452	36.13	0.5	PASS

CH7

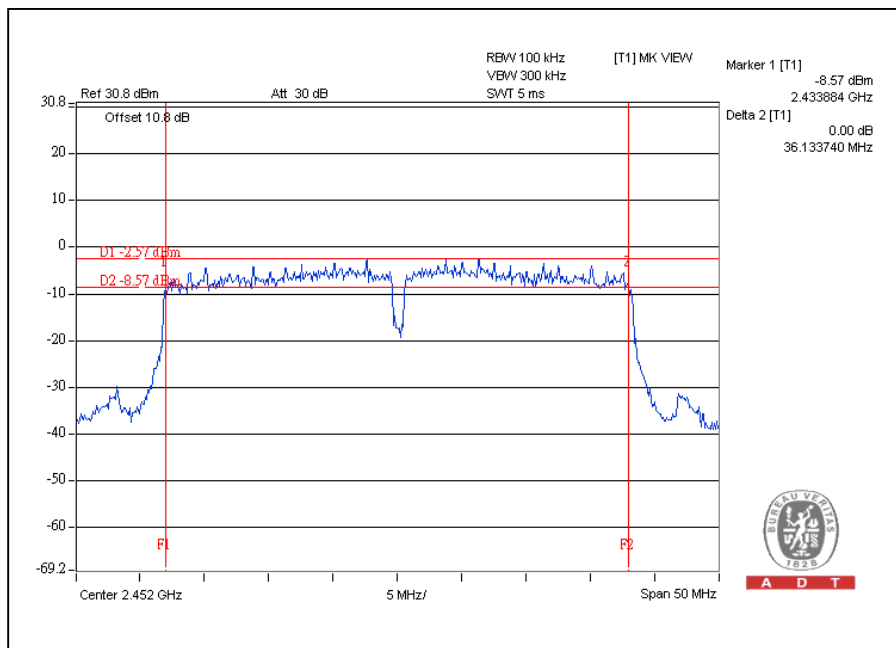

4.4 MAXIMUM PEAK OUTPUT POWER

4.4.1 LIMITS OF MAXIMUM PEAK OUTPUT POWER MEASUREMENT

The Maximum Peak Output Power Measurement is 30dBm.

4.4.2 INSTRUMENTS

DESCRIPTION & MANUFACTURER	MODEL NO.	SERIAL NO.	CALIBRATED DATE	CALIBRATED UNTIL
Anritsu Power Meter	ML2495A	0824006	May 04, 2010	May 03, 2011
Pulse Power Sensor	MA2411B	0738172	May 04, 2010	May 03, 2011

NOTE:

The calibration interval of the above test instruments is 12 months and the calibrations are traceable to NML/ROC and NIST/USA.

4.4.3 TEST PROCEDURES

1. The transmitter output was connected to the power meter through an attenuator; the bandwidth of the fundamental frequency was measured with the power meter.
2. Record the power level.

4.4.4 DEVIATION FROM TEST STANDARD

No deviation

4.4.5 TEST SETUP

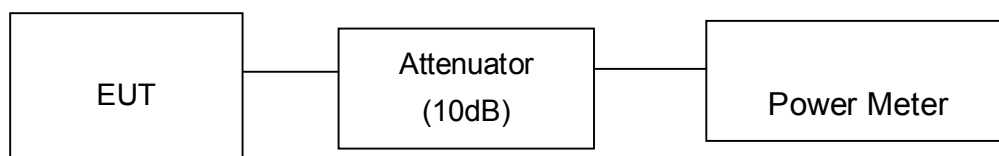

4.4.6 EUT OPERATING CONDITIONS

Same as Item 4.3.6

4.4.7 TEST RESULTS

802.11b DSSS MODULATION:

CHANNEL	CHANNEL FREQUENCY (MHz)	PEAK POWER OUTPUT (mW)	PEAK POWER OUTPUT (dBm)	PEAK POWER LIMIT (dBm)	PASS / FAIL
1	2412	138.0	21.4	30	PASS
6	2437	162.2	22.1	30	PASS
11	2462	138.0	21.4	30	PASS

802.11g OFDM MODULATION:

CHANNEL	CHANNEL FREQUENCY (MHz)	PEAK POWER OUTPUT (mW)	PEAK POWER OUTPUT (dBm)	PEAK POWER LIMIT (dBm)	PASS / FAIL
1	2412	204.2	23.1	30	PASS
6	2437	371.5	25.7	30	PASS
11	2462	204.2	23.1	30	PASS

802.11n (20MHz) OFDM MODULATION:

CHANNEL	CHANNEL FREQUENCY (MHz)	PEAK POWER OUTPUT (dBm)		TOTAL PEAK POWER (mW)	TOTAL PEAK POWER (dBm)	PEAK POWER LIMIT (dBm)	PASS / FAIL
		CHAIN(0)	CHAIN(1)				
1	2412	23.1	22.9	399.2	26.0	30	PASS
6	2437	25.0	24.8	618.2	27.9	30	PASS
11	2462	23.2	23.0	408.5	26.1	30	PASS



A D T

802.11n (40MHz) OFDM MODULATION:

CHANNEL	CHANNEL FREQUENCY (MHz)	PEAK POWER OUTPUT (dBm)		TOTAL PEAK POWER (mW)	TOTAL PEAK POWER (dBm)	PEAK POWER LIMIT (dBm)	PASS / FAIL
		CHAIN(0)	CHAIN(1)				
1	2422	20.9	21.1	251.9	24.0	30	PASS
4	2437	23.1	23.9	449.6	26.5	30	PASS
7	2452	20.4	21.3	244.5	23.9	30	PASS

4.5 POWER SPECTRAL DENSITY MEASUREMENT

4.5.1 LIMITS OF POWER SPECTRAL DENSITY MEASUREMENT

The Maximum of Power Spectral Density Measurement is 8dBm.

4.5.2 TEST INSTRUMENTS

DESCRIPTION & MANUFACTURER	MODEL NO.	SERIAL NO.	CALIBRATED DATE	CALIBRATED UNTIL
R&S SPECTRUM ANALYZER	E4446A	MY48250253	Aug. 02, 2010	Aug. 01, 2011

NOTE:

1. The calibration interval of the above test instruments is 12 months and the calibrations are traceable to NML/ROC and NIST/USA.

4.5.3 TEST PROCEDURE

The transmitter output was connected to the spectrum analyzer through an attenuator, the bandwidth of the fundamental frequency was measured with the spectrum analyzer using 3kHz RBW and 30kHz VBW, set sweep time = span/3kHz. The power spectral density was measured and recorded.

The sweep time is allowed to be longer than span/3kHz for a full response of the mixer in the spectrum analyzer.

4.5.4 DEVIATION FROM TEST STANDARD

No deviation

4.5.5 TEST SETUP

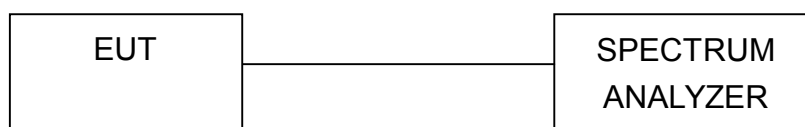

4.5.6 EUT OPERATING CONDITION

Same as Item 4.3.6



A D T

4.5.7 TEST RESULTS

802.11b DSSS MODULATION:

CHANNEL	CHANNEL FREQUENCY (MHz)	RF POWER LEVEL IN 3kHz BW (dBm)	MAXIMUM LIMIT (dBm)	PASS / FAIL
1	2412	-5.6	8	PASS
6	2437	-4.8	8	PASS
11	2462	-4.7	8	PASS

CH11

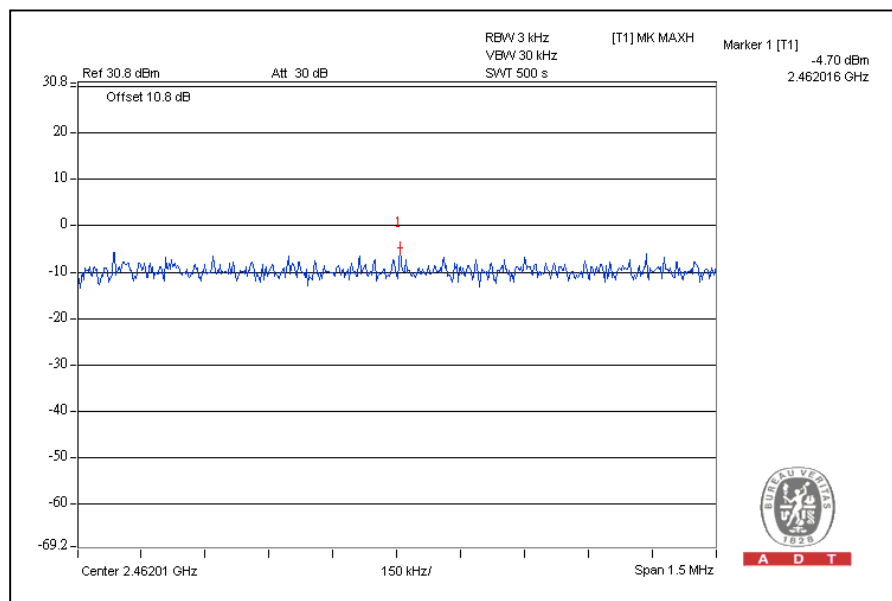



A D T

802.11g OFDM MODULATION:

CHANNEL	CHANNEL FREQUENCY (MHz)	RF POWER LEVEL IN 3kHz BW (dBm)	MAXIMUM LIMIT (dBm)	PASS / FAIL
1	2412	-10.0	8	PASS
6	2437	-7.7	8	PASS
11	2462	-12.4	8	PASS

CH6

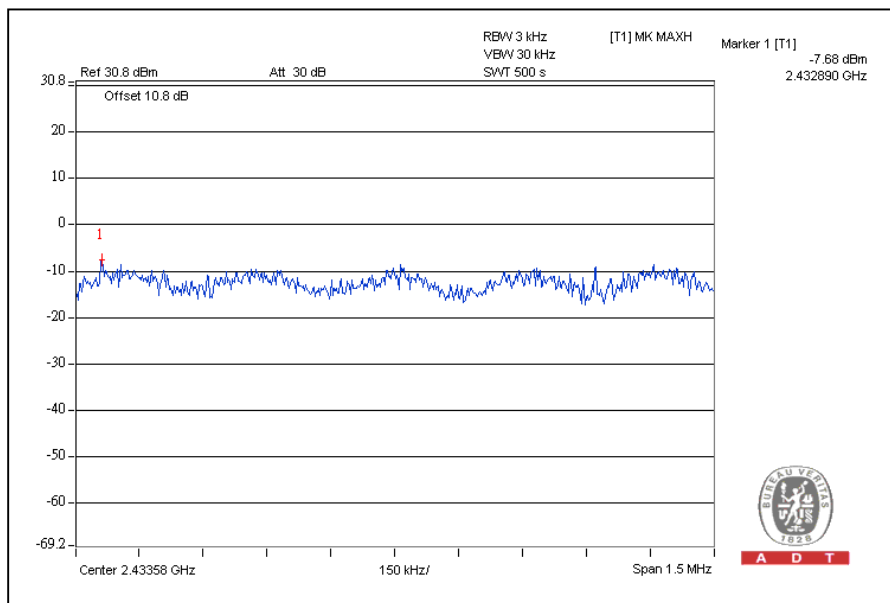



A D T

802.11n (20MHz) OFDM MODULATION:

CHANNEL	CHANNEL FREQUENCY (MHz)	RF POWER LEVEL IN 3kHz BW (dBm)		TOTAL POWER DENSITY (dBm)	MAXIMUM LIMIT (dBm)	PASS / FAIL
		CHAIN(0)	CHAIN(1)			
1	2412	-10.4	-12.5	-8.3	8	PASS
6	2437	-9.9	-9.2	-6.5	8	PASS
11	2462	-11.1	-12.8	-8.9	8	PASS

For Chain(1): CH6

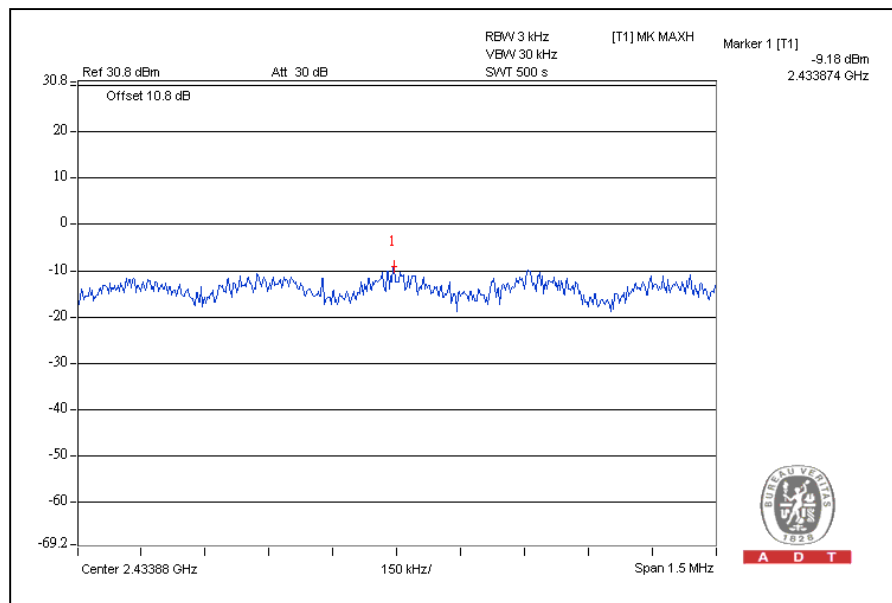

802.11n (40MHz) OFDM MODULATION:

CHANNEL	CHANNEL FREQUENCY (MHz)	RF POWER LEVEL IN 3kHz BW (dBm)		TOTAL POWER DENSITY (dBm)	MAXIMUM LIMIT (dBm)	PASS / FAIL
		CHAIN(0)	CHAIN(1)			
1	2422	-11.0	-16.6	-9.9	8	PASS
4	2437	-9.6	-14.3	-8.3	8	PASS
7	2452	-13.4	-16.6	-11.7	8	PASS

For Chain (0): CH4

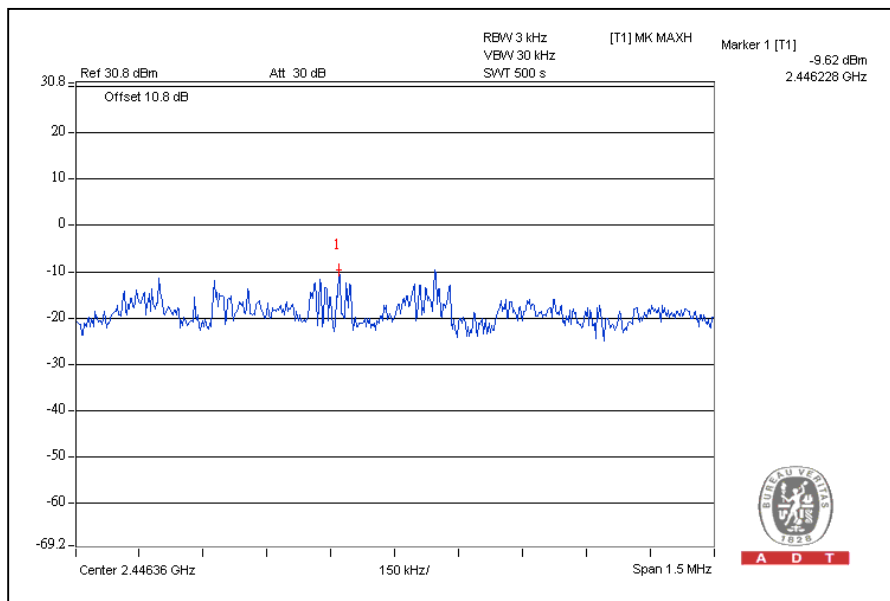

4.6 CONDUCTED OUT-BAND EMISSION MEASUREMENT

4.6.1 LIMITS OF CONDUCTED OUT-BAND EMISSION MEASUREMENT

Below -20dB of the highest emission level of operating band (in 100kHz Resolution Bandwidth).

4.6.2 TEST INSTRUMENTS

DESCRIPTION & MANUFACTURER	MODEL NO.	SERIAL NO.	CALIBRATED DATE	CALIBRATED UNTIL
R&S SPECTRUM ANALYZER	E4446A	MY482502 53	Aug. 02, 2010	Aug. 01, 2011

NOTE:

1. The calibration interval of the above test instruments is 12 months and the calibrations are traceable to NML/ROC and NIST/USA.

4.6.3 TEST PROCEDURE

The transmitter output was connected to the spectrum analyzer via a low loss cable. Set RBW of spectrum analyzer to 100kHz and VBW of spectrum analyzer to 300kHz with suitable frequency span including 100 MHz or 200 MHz bandwidth from band edge. The band edges was measured and recorded.

The spectrum plots (RBW = 100kHz, VBW = 300kHz) are attached on the following pages.

4.6.4 DEVIATION FROM TEST STANDARD

No deviation

4.6.5 EUT OPERATING CONDITION

Same as Item 4.3.6

4.6.6 TEST RESULTS

The spectrum plots are attached on the following images. D1 line indicates the highest level, and D2 line indicates the 20dB offset below D1. It shows compliance with the requirement in part 15.247(d).

802.11b DSSS MODULATION:

CH1

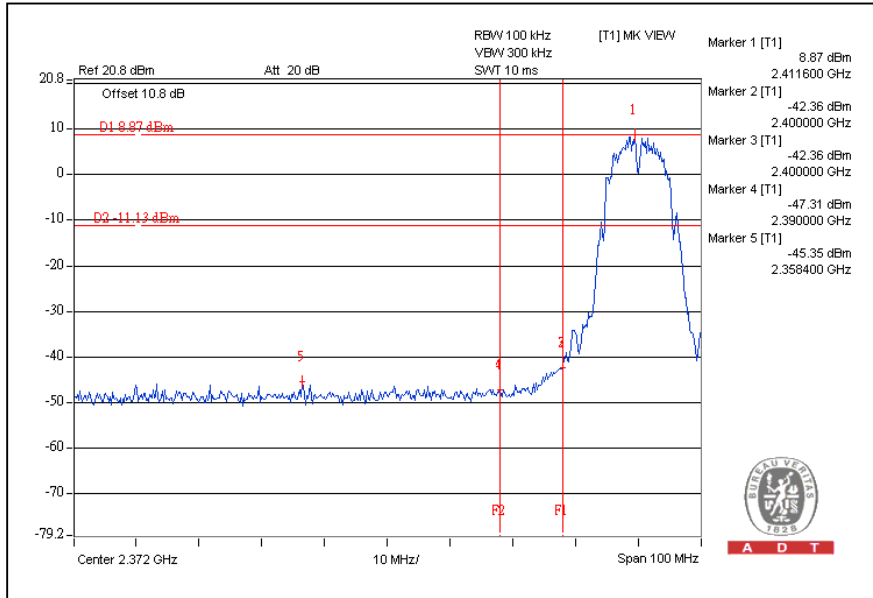

CH11

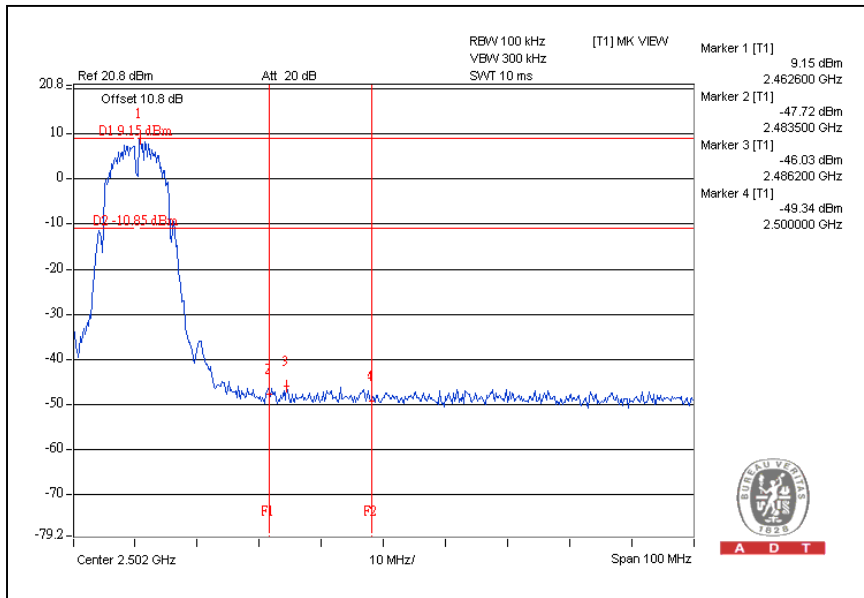



A D T

CH1

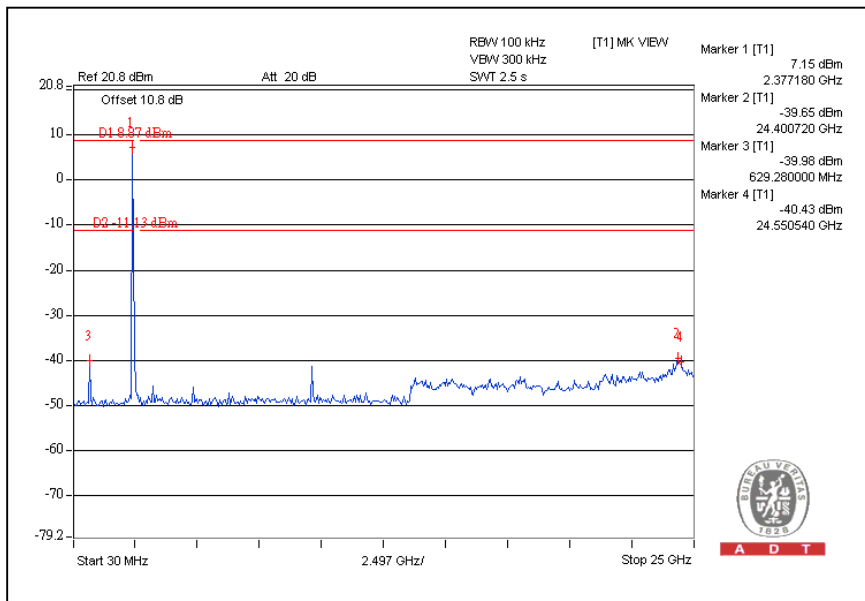

CH11

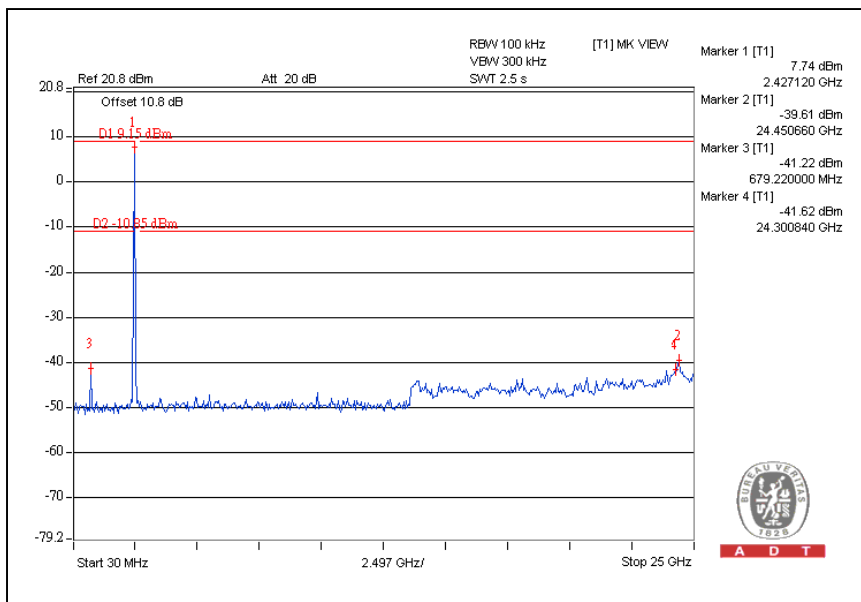

802.11g OFDM MODULATION:

CH1

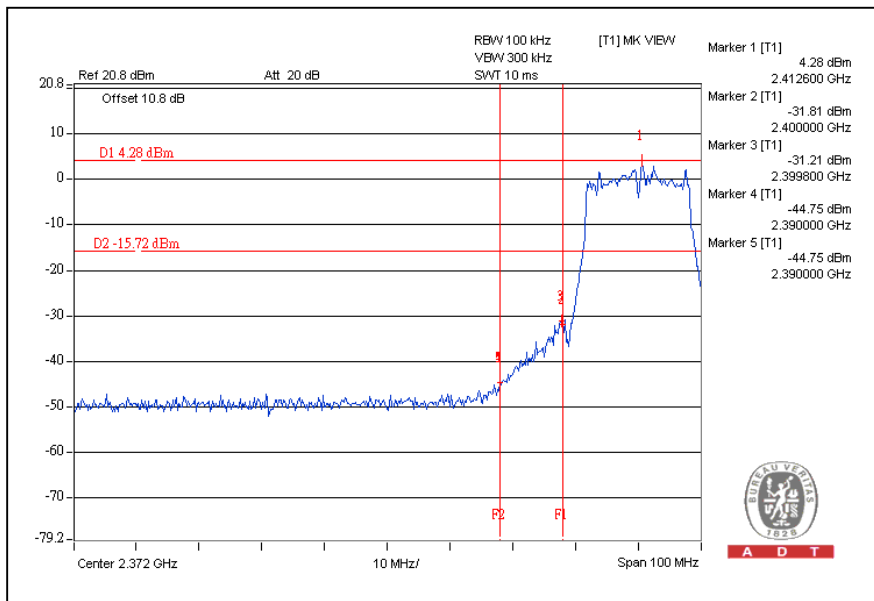

CH11

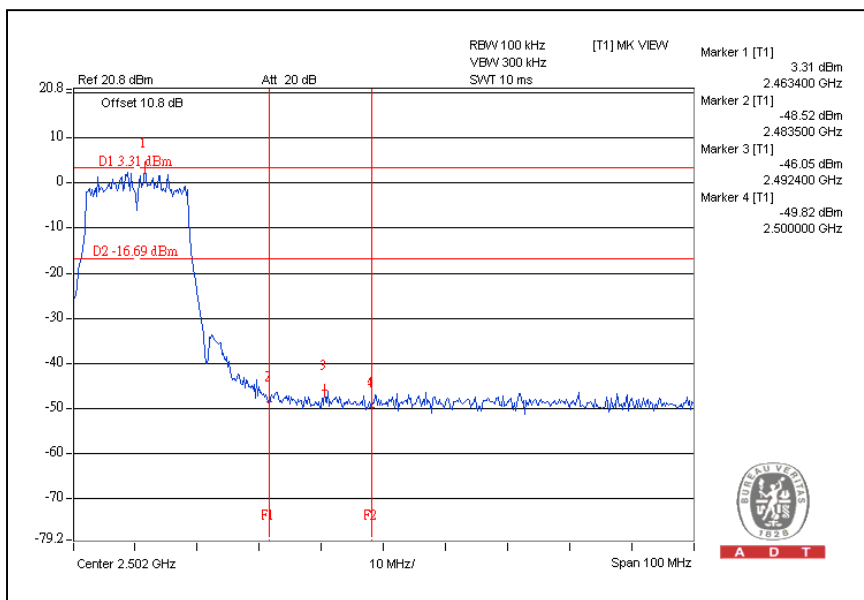



A D T

CH1

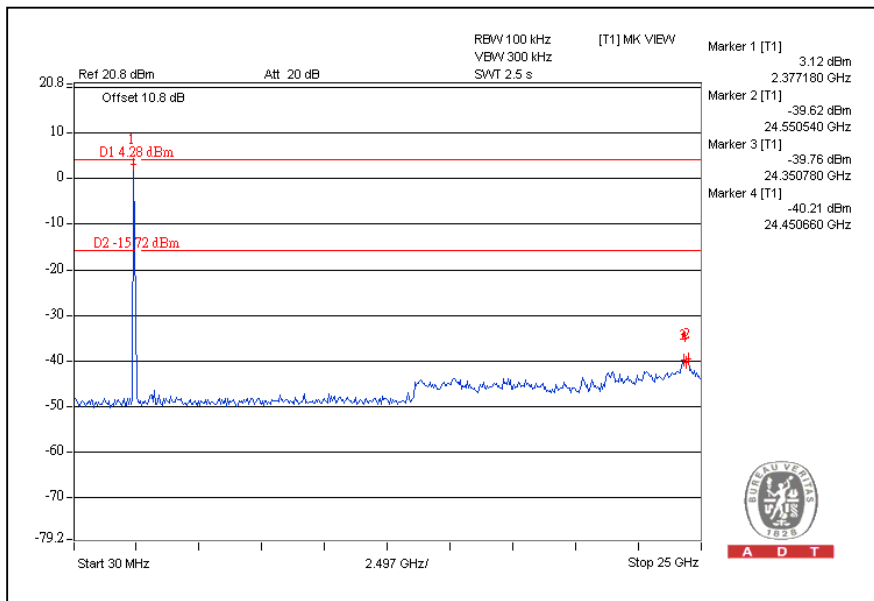

CH11

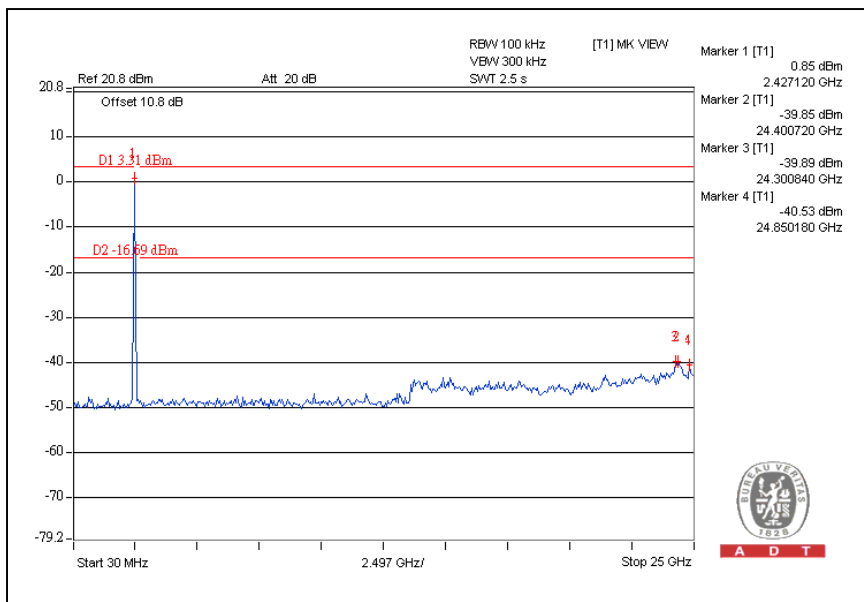



A D T

802.11n (20MHz) OFDM MODULATION:

CH1

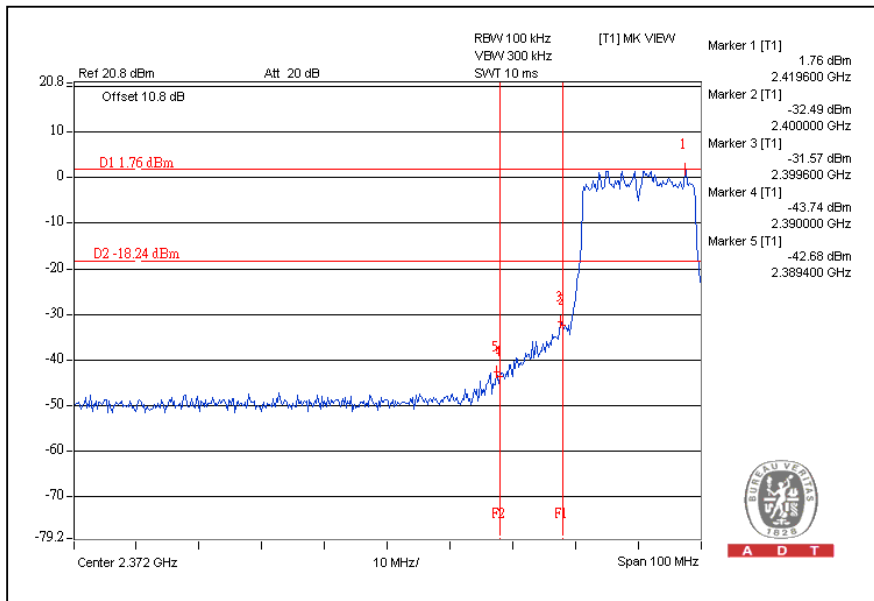

CH11

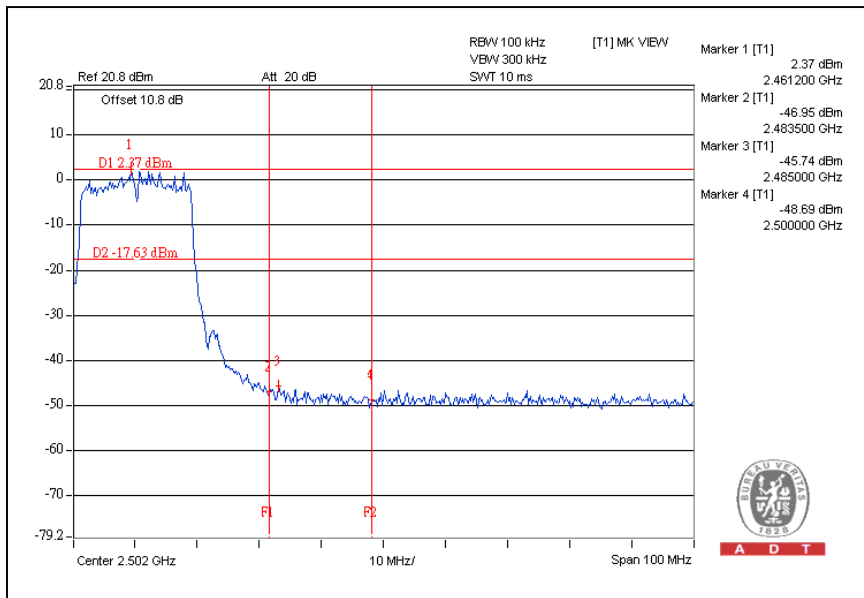



A D T

CH1

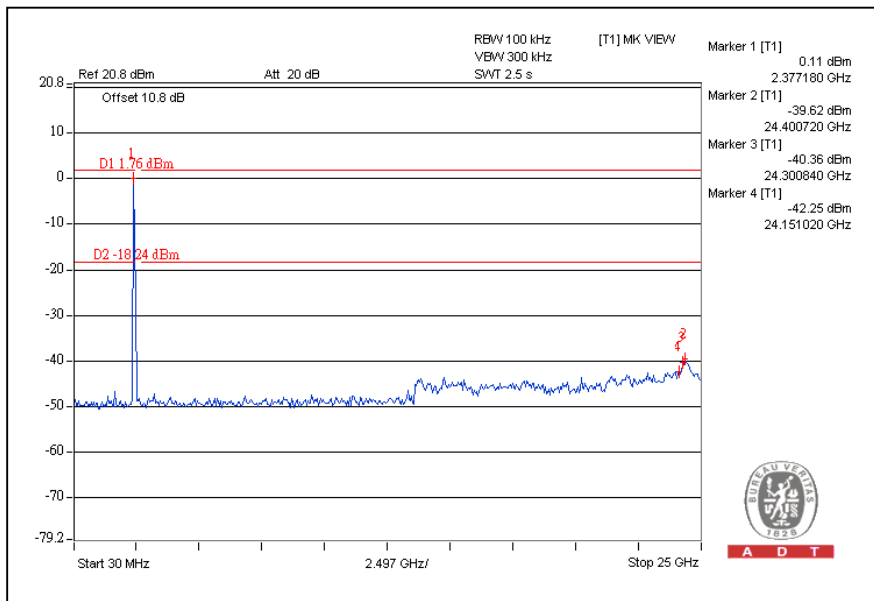

CH11

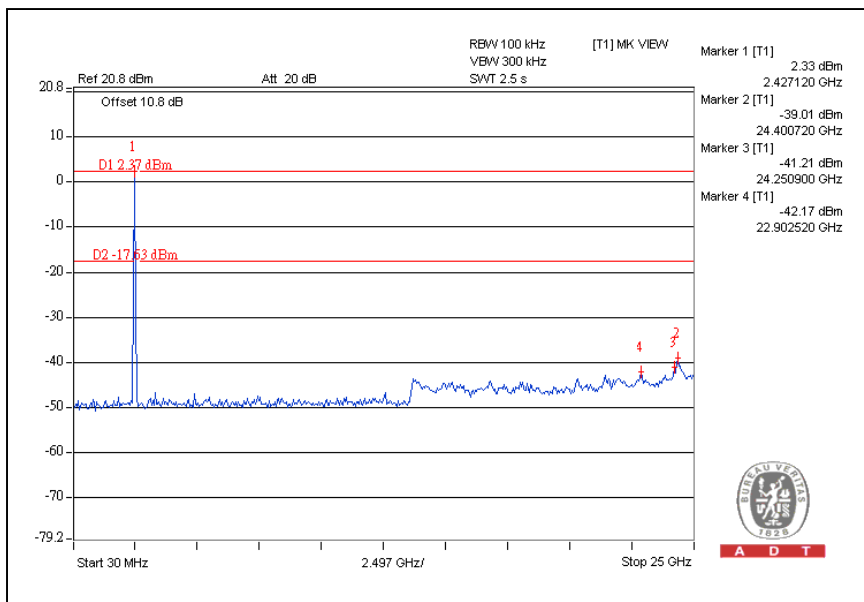

802.11n (40MHz) OFDM MODULATION:

CH1

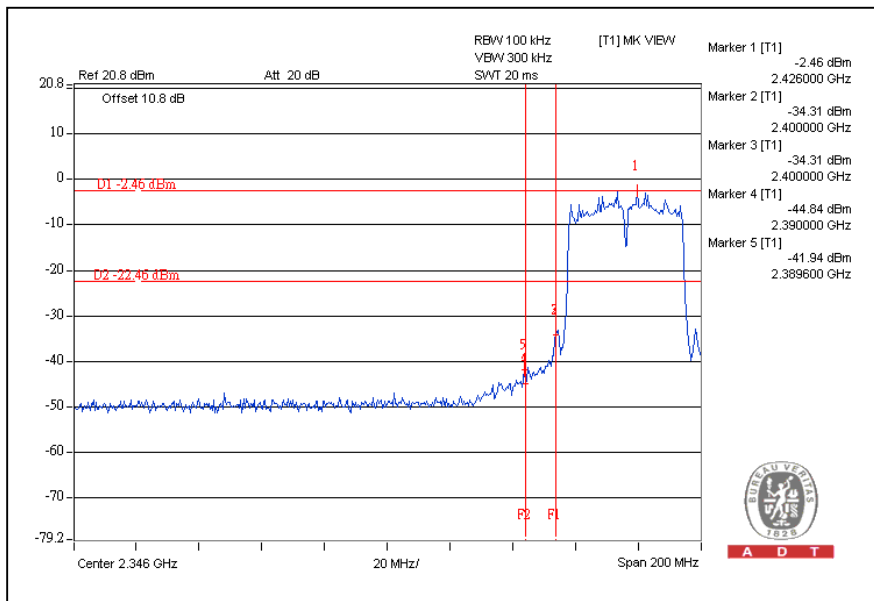

CH7

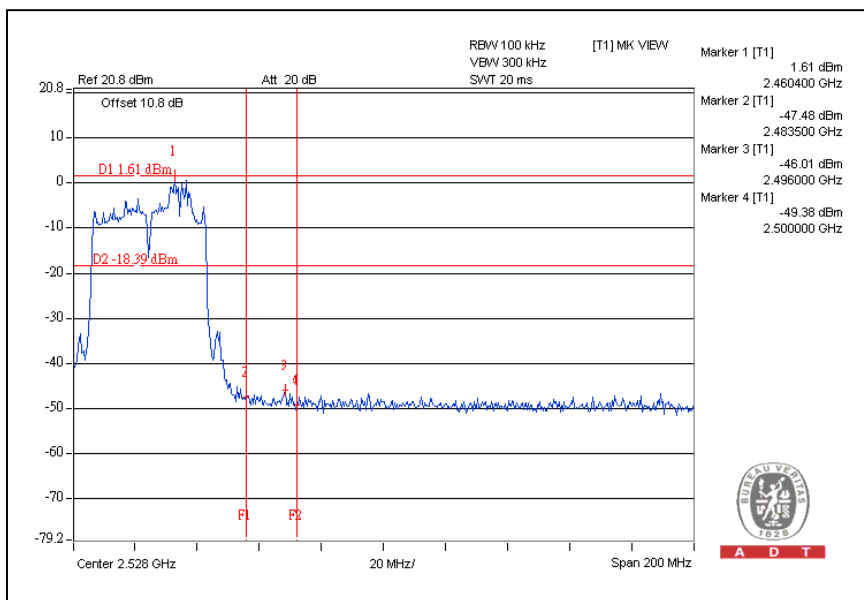



A D T

CH1

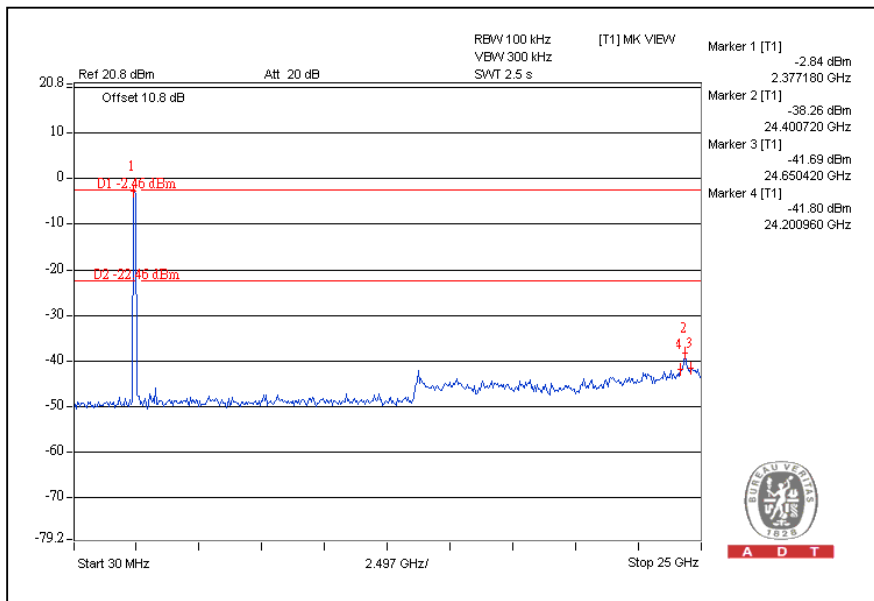

CH7

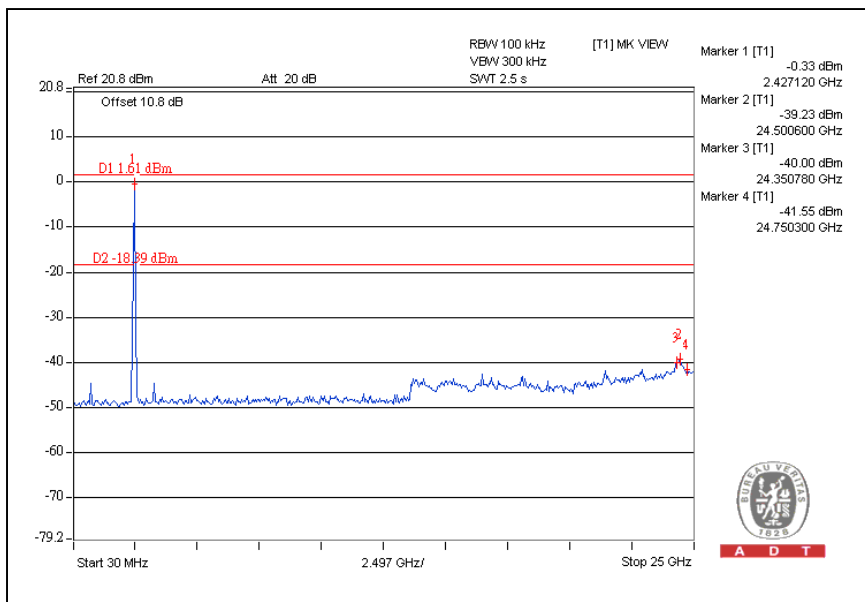



5. INFORMATION ON THE TESTING LABORATORIES

We, Bureau Veritas Consumer Products Services (H.K.) Ltd., Taoyuan Branch, were founded in 1988 to provide our best service in EMC, Radio, Telecom and Safety consultation. Our laboratories are accredited and approved according to ISO/IEC 17025:

Copies of accreditation certificates of our laboratories obtained from approval agencies can be downloaded from our web site: www.adt.com.tw/index.5/phtml.

If you have any comments, please feel free to contact us at the following:

Linko EMC/RF Lab:

Tel: 886-2-26052180

Fax: 886-2-26052943

Hsin Chu EMC/RF Lab:

Tel: 886-3-5935343

Fax: 886-3-5935342

Hwa Ya EMC/RF/Safety/Telecom Lab:

Tel: 886-3-3183232

Fax: 886-3-3185050

Email: service@adt.com.tw

Web Site: www.adt.com.tw

The address and road map of all our labs can be found in our web site also.



A D T

6.APPENDIX A - MODIFICATIONS RECORDERS FOR ENGINEERING CHANGES TO THE EUT BY THE LAB

No any modifications are made to the EUT by the lab during the test.

--- END ---