

FCC Test Report (BT-LE)

Report No.: RF171208E04-3

FCC ID: Q87-08011

Test Model: WHW03 V2

Series Model: A03 V2

Received Date: Dec. 08, 2017

Test Date: Dec. 20, 2017 to Jan. 11, 2018

Issued Date: Feb. 13, 2018

Applicant: Linksys LLC

Address: 121 Theory Drive, Irvine, CA 92617, USA

Issued By: Bureau Veritas Consumer Products Services (H.K.) Ltd., Taoyuan Branch
Hsin Chu Laboratory

Lab Address: E-2, No.1, Li Hsin 1st Road, Hsinchu Science Park, Hsinchu City 300,
Taiwan R.O.C.

Test Location: E-2, No.1, Li Hsin 1st Road, Hsinchu Science Park, Hsinchu City 300,
Taiwan R.O.C.

**FCC Registration /
Designation Number:** 723255 / TW2022



This report is for your exclusive use. Any copying or replication of this report to or for any other person or entity, or use of our name or trademark, is permitted only with our prior written permission. This report sets forth our findings solely with respect to the test samples identified herein. The results set forth in this report are not indicative or representative of the quality or characteristics of the lot from which a test sample was taken or any similar or identical product unless specifically and expressly noted. Our report includes all of the tests requested by you and the results thereof based upon the information that you provided to us. You have 60 days from date of issuance of this report to notify us of any material error or omission caused by our negligence, provided, however, that such notice shall be in writing and shall specifically address the issue you wish to raise. A failure to raise such issue within the prescribed time shall constitute your unqualified acceptance of the completeness of this report, the tests conducted and the correctness of the report contents. Unless specific mention, the uncertainty of measurement has been explicitly taken into account to declare the compliance or non-compliance to the specification. The report must not be used by the client to claim product certification, approval, or endorsement by TAF or any government agencies.

Table of Contents

Release Control Record	4
1 Certificate of Conformity	5
2 Summary of Test Results	6
2.1 Measurement Uncertainty	6
2.2 Modification Record	6
3 General Information	7
3.1 General Description of EUT (BT-LE)	7
3.2 Description of Test Modes	9
3.2.1 Test Mode Applicability and Tested Channel Detail	10
3.3 Description of Support Units	12
3.4 Duty Cycle of Test Signal	13
3.4.1 Configuration of System under Test	14
3.5 General Description of Applied Standards	15
4 Test Types and Results	16
4.1 Radiated Emission and Bandedge Measurement	16
4.1.1 Limits of Radiated Emission and Bandedge Measurement	16
4.1.2 Test Instruments	17
4.1.3 Test Procedures	18
4.1.4 Deviation from Test Standard	18
4.1.5 Test Setup	19
4.1.6 EUT Operating Conditions	20
4.1.7 Test Results	21
4.2 Conducted Emission Measurement	25
4.2.1 Limits of Conducted Emission Measurement	25
4.2.2 Test Instruments	25
4.2.3 Test Procedures	26
4.2.4 Deviation from Test Standard	26
4.2.5 Test Setup	26
4.2.6 EUT Operating Conditions	26
4.2.7 Test Results (Mode 1)	27
4.2.8 Test Results (Mode 2)	29
4.2.9 Test Results (Mode 3)	31
4.2.10 Test Results (Mode 4)	33
4.3 6dB Bandwidth Measurement	35
4.3.1 Limits of 6dB Bandwidth Measurement	35
4.3.2 Test Setup	35
4.3.3 Test Instruments	35
4.3.4 Test Procedure	35
4.3.5 Deviation from Test Standard	35
4.3.6 EUT Operating Conditions	35
4.3.7 Test Result	36
4.4 Conducted Output Power Measurement	37
4.4.1 Limits of Conducted Output Power Measurement	37
4.4.2 Test Setup	37
4.4.3 Test Instruments	37
4.4.4 Test Procedures	37
4.4.5 Deviation from Test Standard	37
4.4.6 EUT Operating Conditions	37
4.4.7 Test Results	38
4.5 Power Spectral Density Measurement	39
4.5.1 Limits of Power Spectral Density Measurement	39
4.5.2 Test Setup	39
4.5.3 Test Instruments	39

4.5.4	Test Procedure	39
4.5.5	Deviation from Test Standard	39
4.5.6	EUT Operating Condition	39
4.5.7	Test Results	40
4.6	Conducted Out of Band Emission Measurement	41
4.6.1	Limits of Conducted Out of Band Emission Measurement.....	41
4.6.2	Test Setup.....	41
4.6.3	Test Instruments	41
4.6.4	Test Procedure	41
4.6.5	Deviation from Test Standard	41
4.6.6	EUT Operating Condition	41
4.6.7	Test Results	42
5	Pictures of Test Arrangements.....	43
	Appendix – Information on the Testing Laboratories	44

Release Control Record

Issue No.	Description	Date Issued
RF171208E04-3	Original release.	Feb. 13, 2018

1 Certificate of Conformity

Product: WHOLE HOME WI-FI

Brand: Linksys

Test Model: WHW03 V2

Series Model: A03 V2

Sample Status: ENGINEERING SAMPLE

Applicant: Linksys LLC

Test Date: Dec. 20, 2017 to Jan. 11, 2018

Standards: 47 CFR FCC Part 15, Subpart C (Section 15.247)
ANSI C63.10: 2013

The above equipment has been tested by **Bureau Veritas Consumer Products Services (H.K.) Ltd., Taoyuan Branch**, and found compliance with the requirement of the above standards. The test record, data evaluation & Equipment Under Test (EUT) configurations represented herein are true and accurate accounts of the measurements of the sample's EMC characteristics under the conditions specified in this report.

Prepared by : Wendy Wu , **Date:** Feb. 13, 2018
Wendy Wu / Specialist

Approved by : May Chen , **Date:** Feb. 13, 2018
May Chen / Manager

2 Summary of Test Results

47 CFR FCC Part 15, Subpart C (SECTION 15.247)			
FCC Clause	Test Item	Result	Remarks
15.207	AC Power Conducted Emission	PASS	Meet the requirement of limit. Minimum passing margin is -4.81dB at 0.42344MHz.
15.205 & 209 & 15.247(d)	Radiated Emissions & Band Edge Measurement	PASS	Meet the requirement of limit. Minimum passing margin is -3.6dB at 36.91MHz.
15.247(d)	Antenna Port Emission	PASS	Meet the requirement of limit.
15.247(a)(2)	6dB bandwidth	PASS	Meet the requirement of limit.
15.247(b)	Conducted power	PASS	Meet the requirement of limit.
15.247(e)	Power Spectral Density	PASS	Meet the requirement of limit.
15.203	Antenna Requirement	PASS	Antenna connector is i-pex(MHF) not a standard connector.

2.1 Measurement Uncertainty

Where relevant, the following measurement uncertainty levels have been estimated for tests performed on the EUT as specified in CISPR 16-4-2:

Measurement	Frequency	Expanded Uncertainty (k=2) (\pm)
Conducted Emissions at mains ports	150kHz ~ 30MHz	1.84 dB
Radiated Emissions up to 1 GHz	30MHz ~ 1GHz	5.30 dB
	1GHz ~ 6GHz	5.16 dB
Radiated Emissions above 1 GHz	6GHz ~ 18GHz	4.91 dB
	18GHz ~ 40GHz	5.30 dB

2.2 Modification Record

There were no modifications required for compliance.

3 General Information

3.1 General Description of EUT (BT-LE)

Product	WHOLE HOME WI-FI
Brand	Linksys
Test Model	WHW03 V2
Series Model	A03 V2
Status of EUT	ENGINEERING SAMPLE
Driver version	WNC_VELOP_V2_20180206_V0.9
Power Supply Rating	12Vdc from power adapter
Modulation Type	GFSK
Modulation Technology	DTS
Transfer Rate	Up to 1Mbps
Operating Frequency	2402MHz ~ 2480MHz
Number of Channel	40
Output Power	8.241mW
Antenna Type	Refer to Note
Antenna Connector	Refer to Note
Accessory Device	Adapter x 1
Data Cable Supplied	NA

Note:

- There are WLAN, Bluetooth and Zigbee technology used for the EUT. The EUT has below radios as following table:

Radio 1	Radio 2	Radio 3	Radio 4
WLAN 2.4GHz + 5GHz (low band)	WLAN 5GHz (high band)	Bluetooth	Zigbee

- The EUT has below model names, which are identical to each other in all aspects except for the following table:

Brand	Model Name	Different
Linksys	WHW03 V2	For marketing request
	A03 V2	

From the above models, model: **WHW03 V2** was selected as representative model for the test and its data was recorded in this report.

- Simultaneously transmission condition.

Condition	Technology				
1	WLAN 2.4GHz	WLAN 5GHz (low band)	WLAN 5GHz (high band)	Bluetooth	Zigbee

Note: The emission of the simultaneous operation has been evaluated and no non-compliance was found.

4. The EUT must be supplied with a power adapter and following different models could be chosen as following table:

No.	Brand	Model No.	Spec.	Plug
1	LEI	IU24-6120200-WP	Input: 100-240Vac, 0.7A, 50-60Hz Output: 12Vdc, 2A DC output cable (Unshielded, 1.8m)	Universal
2	LEI	MU24A6120200-A1	Input: 100-240Vac, 0.7A, 50-60Hz Output: 12Vdc, 2A DC output cable (Unshielded, 1.8m)	FCC
3	Ktec	KSA-24H-120200D5	Input: 100-240Vac, 0.7A, 50-60Hz Output: 12Vdc, 2A DC output cable (Unshielded, 1.8m)	Universal
4	Ktec	KSA-24H-120200HU	Input: 100-240Vac, 0.7A, 50-60Hz Output: 12Vdc, 2A DC output cable (Unshielded, 1.8m)	FCC

Note: From the above models, the worst radiated emission test was found in **Adapter 1**. Therefore only the test data of the modes were recorded in this report.

5. The DDR3 Memory of EUT as following table

Item	Brand	Model No.	Different
Main source	SK HYNIX	H5TC4G63CFR-PBA	1. For maketing request. 2. DDR3 Memory.
Second source	NANYA	NT5CC256M16EP-EK	

Note: From the above models, the worst case was found in **Main source**. Therefore only the test data of the modes were recorded in this report.

6. The antennas provided to the EUT, please refer to the following table:

Bluetooth						
Ant No.	Brand	Model	Antenna Gain (dBi)	Frequency rang (GHz)	Antenna type	Connector type
1	Aristotle	RFA-BT-9267	1.69	2.4~2.4835	Dipole	i-pex(MHF)
Zigbee						
Ant No.	Brand	Model	Antenna Gain (dBi)	Frequency rang (GHz)	Antenna type	Connector type
1	Aristotle	RFA-ZB-9267	0.85	2.4~2.4835	Dipole	i-pex(MHF)
WLAN						
Ant No.	Brand	Model	Antenna Gain (dBi)	Frequency rang (GHz)	Antenna type	Connector type
1	Aristotle	RFA-05-9267-L	3.55	5.5~5.825	Dipole	i-pex(MHF)
2	Aristotle	RFA-05-9267-R	3.87	5.5~5.825	Dipole	i-pex(MHF)
3	Aristotle	RFA-25-9267-B-V2	3.12	2.4~2.4835	Dipole	i-pex(MHF)
			3.77	5.18~5.320		
4	Aristotle	RFA-25-9267-F-V2	3.26	2.4~2.4835	Dipole	i-pex(MHF)
			3.68	5.18~5.320		

7. The above EUT information is declared by manufacturer and for more detailed features description, please refer to the manufacturer's specifications or user's manual.

3.2 Description of Test Modes

40 channels are provided to this EUT:

CHANNEL	FREQ. (MHz)	CHANNEL	FREQ. (MHz)	CHANNEL	FREQ. (MHz)	CHANNEL	FREQ. (MHz)
0	2402	10	2422	20	2442	30	2462
1	2404	11	2424	21	2444	31	2464
2	2406	12	2426	22	2446	32	2466
3	2408	13	2428	23	2448	33	2468
4	2410	14	2430	24	2450	34	2470
5	2412	15	2432	25	2452	35	2472
6	2414	16	2434	26	2454	36	2474
7	2416	17	2436	27	2456	37	2476
8	2418	18	2438	28	2458	38	2478
9	2420	19	2440	29	2460	39	2480

3.2.1 Test Mode Applicability and Tested Channel Detail

EUT CONFIGURE MODE	APPLICABLE TO				DESCRIPTION
	RE \geq 1G	RE<1G	PLC	APCM	
1	√	√	√	√	Power from Adapter 1
2	-	-	√	-	Power from Adapter 2
3	-	-	√	-	Power from Adapter 3
4	-	-	√	-	Power from Adapter 4

Where **RE \geq 1G**: Radiated Emission above 1GHz **RE<1G**: Radiated Emission below 1GHz
PLC: Power Line Conducted Emission **APCM**: Antenna Port Conducted Measurement

Radiated Emission Test (Above 1GHz):

- Pre-Scan has been conducted to determine the worst-case mode from all possible combinations between available modulations, data rates and antenna ports (if EUT with antenna diversity architecture).
- Following channel(s) was (were) selected for the final test as listed below.

AVAILABLE CHANNEL	TESTED CHANNEL	MODULATION TYPE	DATA RATE (Mbps)
0 to 39	0, 19, 39	GFSK	1

Radiated Emission Test (Below 1GHz):

- Pre-Scan has been conducted to determine the worst-case mode from all possible combinations between available modulations, data rates and antenna ports (if EUT with antenna diversity architecture).
- Following channel(s) was (were) selected for the final test as listed below.

AVAILABLE CHANNEL	TESTED CHANNEL	MODULATION TYPE	DATA RATE (Mbps)
0 to 39	39	GFSK	1

Power Line Conducted Emission Test:

- Pre-Scan has been conducted to determine the worst-case mode from all possible combinations between available modulations, data rates and antenna ports (if EUT with antenna diversity architecture).
- Following channel(s) was (were) selected for the final test as listed below.

AVAILABLE CHANNEL	TESTED CHANNEL	MODULATION TYPE	DATA RATE (Mbps)
0 to 39	39	GFSK	1

Antenna Port Conducted Measurement:

- This item includes all test value of each mode, but only includes spectrum plot of worst value of each mode.
- Pre-Scan has been conducted to determine the worst-case mode from all possible combinations between available modulations, data rates and antenna ports (if EUT with antenna diversity architecture).
- Following channel(s) was (were) selected for the final test as listed below.

AVAILABLE CHANNEL	TESTED CHANNEL	MODULATION TYPE	DATA RATE (Mbps)
0 to 39	0, 19, 39	GFSK	1

Test Condition:

APPLICABLE TO	ENVIRONMENTAL CONDITIONS	INPUT POWER	TESTED BY
RE \geq 1G	21deg. C, 65%RH	120Vac, 60Hz	Frank Chuang
RE $<$ 1G	22deg. C, 67%RH	120Vac, 60Hz	Steven Chiang
PLC	24deg. C, 73%RH	120Vac, 60Hz	Andy Ho
APCM	25deg. C, 65%RH	120Vac, 60Hz	Robert Cheng

3.3 Description of Support Units

The EUT has been tested as an independent unit together with other necessary accessories or support units. The following support units or accessories were used to form a representative test configuration during the tests.

ID	Product	Brand	Model No.	Serial No.	FCC ID	Remarks
A.	Laptop	DELL	E6420	B92T3R1	FCC DoC	Provided by Lab
B.	Laptop	DELL	E6420	482T3R1	FCC DoC	Provided by Lab

Note:

1. All power cords of the above support units are non-shielded (1.8m).

ID	Descriptions	Qty.	Length (m)	Shielding (Yes/No)	Cores (Qty.)	Remarks
1.	RJ-45 Cable	1	10	No	0	Provided by Lab
2.	RJ-45 Cable	1	10	No	0	Provided by Lab
3.	DC Cable	1	1.8	No	0	Supplied by client

Note: The core(s) is(are) originally attached to the cable(s).

3.4 Duty Cycle of Test Signal

Duty cycle of test signal is < 98 %, duty factor shall be considered.

Duty cycle = $0.397 \text{ ms} / 0.65 \text{ ms} = 0.611$, Duty factor = $10 * \log(1/0.611) = 2.14$

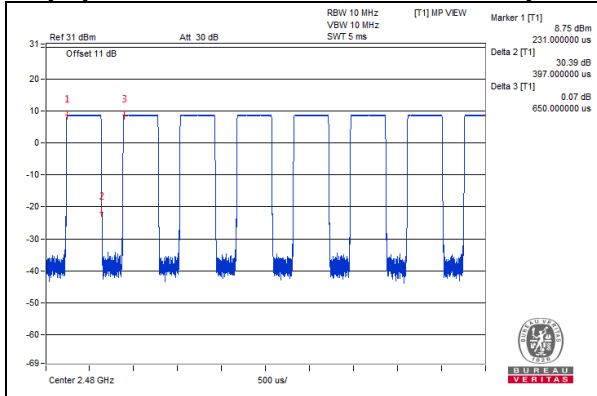

3.4.1 Configuration of System under Test

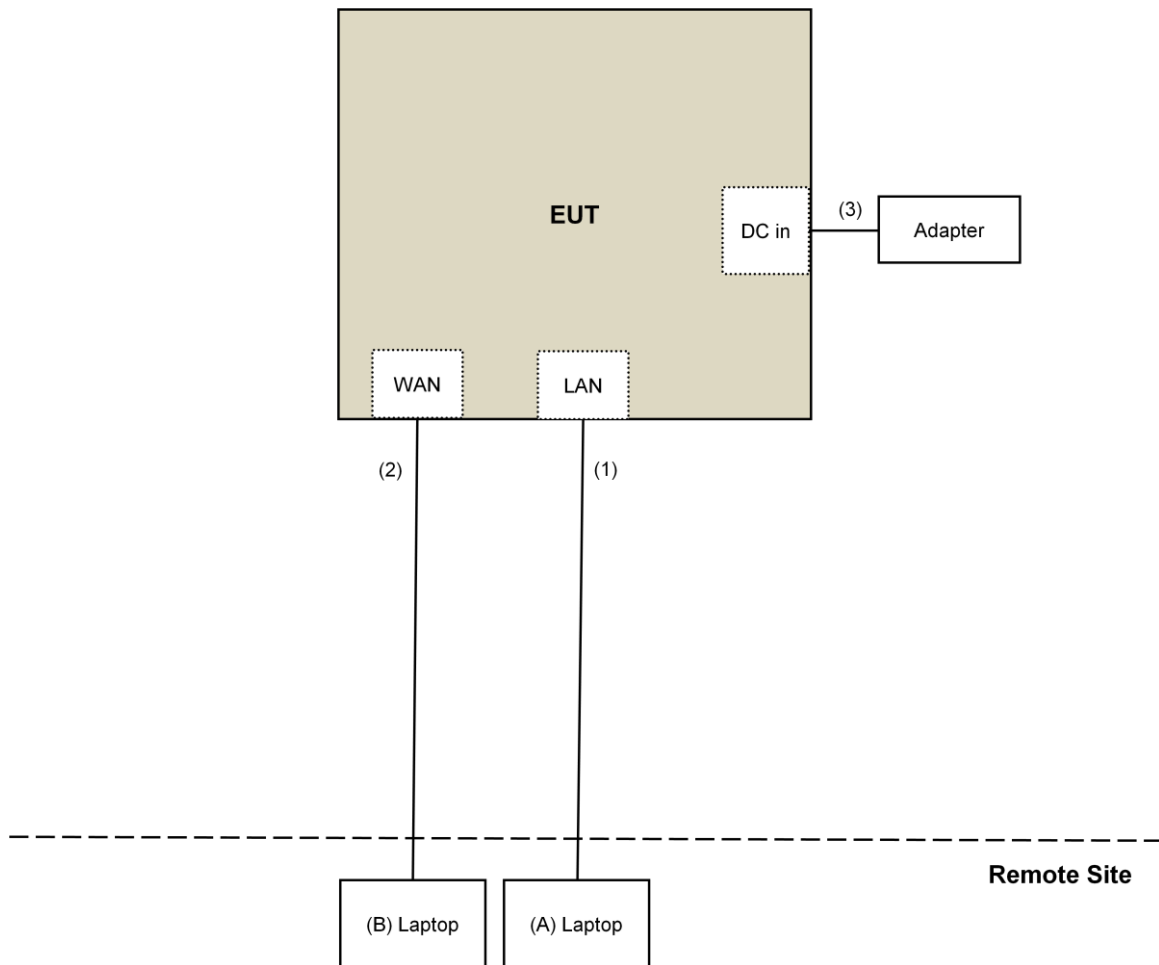

3.5 General Description of Applied Standards

The EUT is a RF Product. According to the specifications of the manufacturer, it must comply with the requirements of the following standards:

FCC Part 15, Subpart C (15.247)
KDB 558074 D01 DTS Meas Guidance v04
ANSI C63.10-2013

All test items have been performed and recorded as per the above standards.

NOTE: The EUT has been verified to comply with the requirements of FCC Part 15, Subpart B, Class B (DoC). The test report has been issued separately.

4 Test Types and Results

4.1 Radiated Emission and Bandedge Measurement

4.1.1 Limits of Radiated Emission and Bandedge Measurement

Radiated emissions which fall in the restricted bands must comply with the radiated emission limits specified as below table. Other emissions shall be at least 20dB below the highest level of the desired power:

Frequencies (MHz)	Field Strength (microvolts/meter)	Measurement Distance (meters)
0.009 ~ 0.490	2400/F(kHz)	300
0.490 ~ 1.705	24000/F(kHz)	30
1.705 ~ 30.0	30	30
30 ~ 88	100	3
88 ~ 216	150	3
216 ~ 960	200	3
Above 960	500	3

NOTE:

1. The lower limit shall apply at the transition frequencies.
2. Emission level (dBuV/m) = 20 log Emission level (uV/m).
3. For frequencies above 1000MHz, the field strength limits are based on average detector, however, the peak field strength of any emission shall not exceed the maximum permitted average limits, specified above by more than 20dB under any condition of modulation.

4.1.2 Test Instruments

DESCRIPTION & MANUFACTURER	MODEL NO.	SERIAL NO.	CALIBRATED DATE	CALIBRATED UNTIL
Test Receiver Keysight	N9038A	MY54450088	July 08, 2017	July 07, 2018
Pre-Amplifier ^(*) EMCI	EMC001340	980142	Jan. 20, 2016	Jan. 19, 2018
Loop Antenna ^(*) Electro-Metrics	EM-6879	264	Dec. 16, 2016	Dec. 15, 2018
RF Cable	NA	LOOPCAB-001 LOOPCAB-002	Jan. 17, 2017	Jan. 16, 2018
Pre-Amplifier Mini-Circuits	ZFL-1000VH2B	AMP-ZFL-01	Nov. 09, 2017	Nov. 08, 2018
Trilog Broadband Antenna SCHWARZBECK	VULB 9168	9168-406	Nov. 29, 2017	Nov. 28, 2018
RF Cable	8D	966-4-1 966-4-2 966-4-3	Apr. 01, 2017	Mar. 31, 2018
Fixed attenuator Mini-Circuits	UNAT-5+	PAD-3m-4-01	Oct. 03, 2017	Oct. 02, 2018
Horn_Antenna SCHWARZBECK	BBHA 9120D	9120D-783	Dec. 12, 2017	Dec. 11, 2018
Pre-Amplifier EMCI	EMC12630SE	980385	Feb. 02, 2017	Feb. 01, 2018
RF Cable	EMC104-SM-SM-1200 EMC104-SM-SM-2000 EMC104-SM-SM-5000	160923 150318 150321	Feb. 02, 2017 Mar. 29, 2017 Mar. 29, 2017	Feb. 01, 2018 Mar. 28, 2018 Mar. 28, 2018
Pre-Amplifier EMCI	EMC184045SE	980387	Feb. 02, 2017	Feb. 01, 2018
Horn_Antenna SCHWARZBECK	BBHA 9170	BBHA9170608	Dec. 14, 2017	Dec. 13, 2018
RF Cable	SUCOFLEX 102	36432/2 36433/2	Jan. 15, 2017	Jan. 14, 2018
Software	ADT_Radiated_V8.7.08	NA	NA	NA
Antenna Tower & Turn Table Max-Full	MF-7802	MF780208410	NA	NA
Boresight Antenna Fixture	FBA-01	FBA-SIP02	NA	NA
Spectrum Analyzer R&S	FSv40	100964	July 1, 2017	June 30, 2018
Power meter Anritsu	ML2495A	1014008	May 11, 2017	May 10, 2018
Power sensor Anritsu	MA2411B	0917122	May 11, 2017	May 10, 2018

Note:

- The calibration interval of the above test instruments is 12 months and the calibrations are traceable to NML/ROC and NIST/USA.
- *The calibration interval of the above test instruments is 24 months and the calibrations are traceable to NML/ROC and NIST/USA.
- The test was performed in 966 Chamber No. 4.
- The CANADA Site Registration No. is 20331-2
- Loop antenna was used for all emissions below 30 MHz.
- Tested Date: Dec. 20, 2017 to Jan. 11, 2018

4.1.3 Test Procedures

For Radiated emission below 30MHz

- a. The EUT was placed on the top of a rotating table 0.8 meters above the ground at a 3 meter chamber room. The table was rotated 360 degrees to determine the position of the highest radiation.
- b. The EUT was set 3 meters away from the interference-receiving antenna, which was mounted on the top of a variable-height antenna tower.
- c. Both X and Y axes of the antenna are set to make the measurement.
- d. For each suspected emission, the EUT was arranged to its worst case and the rotatable table was turned from 0 degrees to 360 degrees to find the maximum reading.
- e. The test-receiver system was set to Quasi-Peak Detect Function and Specified Bandwidth with Maximum Hold Mode.

NOTE:

1. The resolution bandwidth and video bandwidth of test receiver/spectrum analyzer is 9kHz at frequency below 30MHz.

For Radiated emission above 30MHz

- a. The EUT was placed on the top of a rotating table 0.8 meters (for 30MHz ~ 1GHz) / 1.5 meters (for above 1GHz) above the ground at 3 meter chamber room for test. The table was rotated 360 degrees to determine the position of the highest radiation.
- b. The EUT was set 3 meters away from the interference-receiving antenna, which was mounted on the top of a variable-height antenna tower.
- c. The height of antenna is varied from one meter to four meters above the ground to determine the maximum value of the field strength. Both horizontal and vertical polarizations of the antenna are set to make the measurement.
- d. For each suspected emission, the EUT was arranged to its worst case and then the antenna was tuned to heights from 1 meter to 4 meters and the rotatable table was turned from 0 degrees to 360 degrees to find the maximum reading.
- e. The test-receiver system was set to quasi-peak detect function and specified bandwidth with maximum hold mode when the test frequency is below 1 GHz.
- f. The test-receiver system was set to peak and average detect function and specified bandwidth with maximum hold mode when the test frequency is above 1 GHz. If the peak reading value also meets average limit, measurement with the average detector is unnecessary.

Note:

1. The resolution bandwidth and video bandwidth of test receiver/spectrum analyzer is 120kHz for Quasi-peak detection (QP) at frequency below 1GHz.
2. The resolution bandwidth of test receiver/spectrum analyzer is 1 MHz and the video bandwidth is 3 MHz for Peak detection (PK) at frequency above 1GHz.
3. The resolution bandwidth of test receiver/spectrum analyzer is 1MHz and the video bandwidth is $\geq 1/T$ (Duty cycle < 98%) or 10Hz (Duty cycle $\geq 98\%$) for Average detection (AV) at frequency above 1GHz.
4. All modes of operation were investigated and the worst-case emissions are reported.

4.1.4 Deviation from Test Standard

No deviation.

4.1.5 Test Setup

For Radiated emission below 30MHz

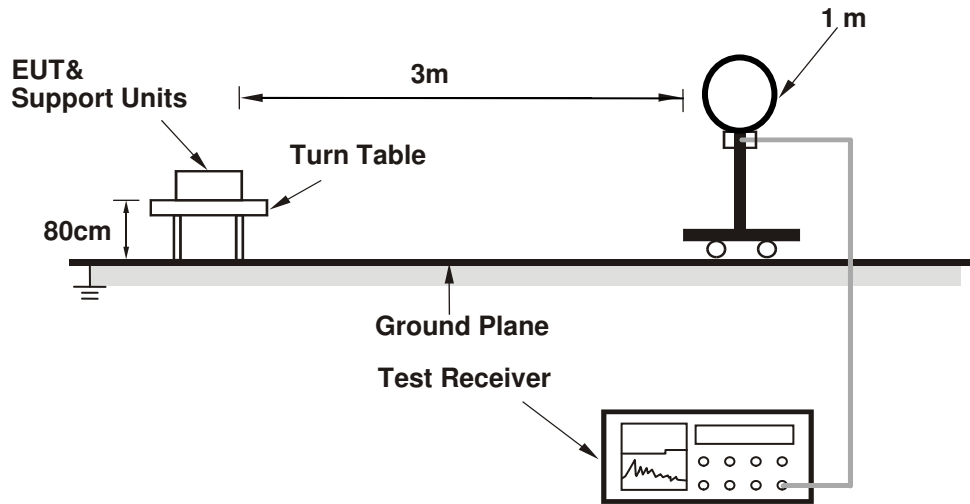

For Radiated emission 30MHz to 1GHz

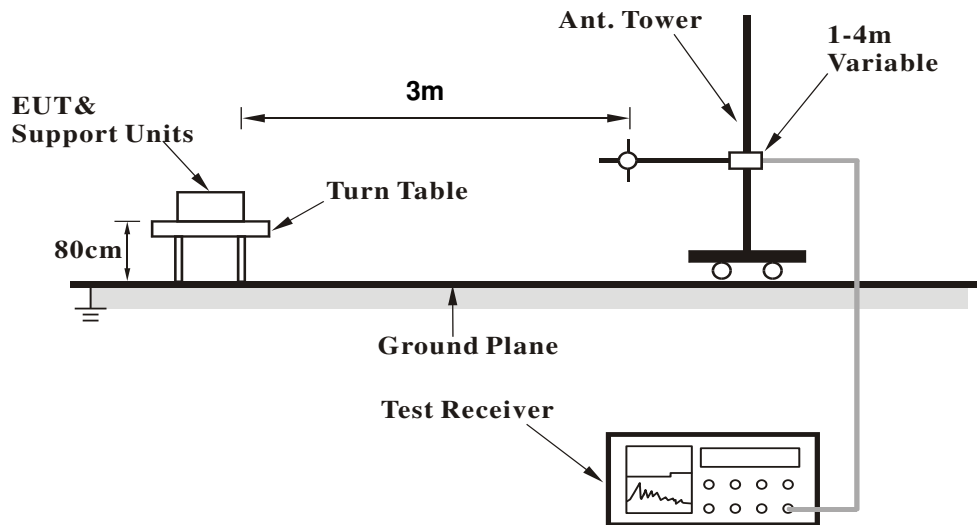

For Radiated emission above 1GHz

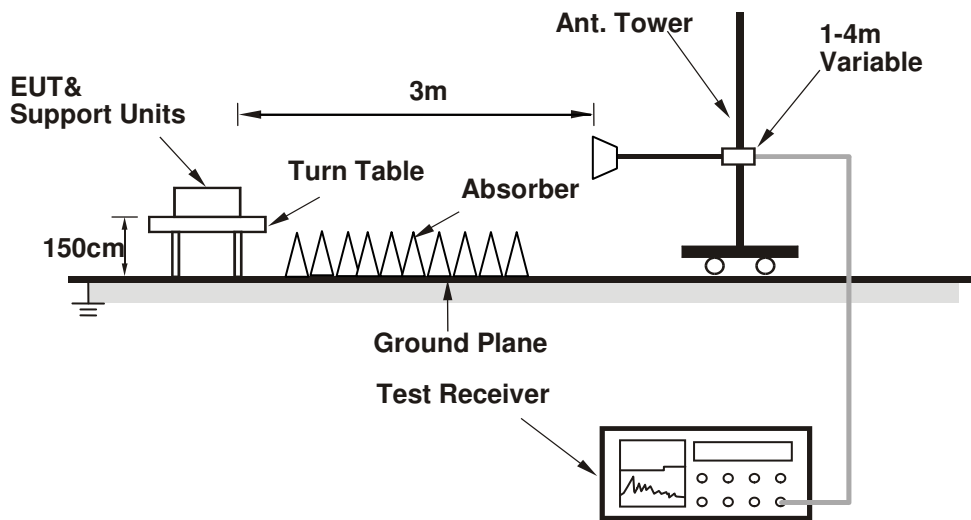

For the actual test configuration, please refer to the attached file (Test Setup Photo).

4.1.6 EUT Operating Conditions

- a. Connected the EUT with the Laptop which is placed on remote site.
- b. Controlling software (Paste 171205_BT+BLE command.txt) has been activated to set the EUT on specific status.

4.1.7 Test Results

Above 1GHz Data:

CHANNEL	TX Channel 0	DETECTOR FUNCTION	Peak (PK)
FREQUENCY RANGE	1GHz ~ 25GHz		Average (AV)

ANTENNA POLARITY & TEST DISTANCE: HORIZONTAL AT 3 M

NO.	FREQ. (MHz)	EMISSION LEVEL (dBuV/m)	LIMIT (dBuV/m)	MARGIN (dB)	ANTENNA HEIGHT (m)	TABLE ANGLE (Degree)	RAW VALUE (dBuV)	CORRECTION FACTOR (dB/m)
1	2390.00	53.6 PK	74.0	-20.4	1.63 H	65	54.6	-1.0
2	2390.00	41.4 AV	54.0	-12.6	1.63 H	65	42.4	-1.0
3	*2402.00	98.2 PK			1.63 H	65	99.2	-1.0
4	*2402.00	96.7 AV			1.63 H	65	97.7	-1.0
5	4804.00	40.5 PK	74.0	-33.5	2.24 H	211	37.4	3.1
6	4804.00	32.5 AV	54.0	-21.5	2.24 H	211	29.4	3.1
7	#7206.00	55.3 PK	74.0	-18.7	1.76 H	188	45.6	9.7
8	#7206.00	46.9 AV	54.0	-7.1	1.76 H	188	37.2	9.7

ANTENNA POLARITY & TEST DISTANCE: VERTICAL AT 3 M

NO.	FREQ. (MHz)	EMISSION LEVEL (dBuV/m)	LIMIT (dBuV/m)	MARGIN (dB)	ANTENNA HEIGHT (m)	TABLE ANGLE (Degree)	RAW VALUE (dBuV)	CORRECTION FACTOR (dB/m)
1	2390.00	54.1 PK	74.0	-19.9	1.00 V	191	55.1	-1.0
2	2390.00	43.2 AV	54.0	-10.8	1.00 V	191	44.2	-1.0
3	*2402.00	106.7 PK			1.00 V	191	107.7	-1.0
4	*2402.00	105.7 AV			1.00 V	191	106.7	-1.0
5	4804.00	40.8 PK	74.0	-33.2	1.00 V	219	37.7	3.1
6	4804.00	32.2 AV	54.0	-21.8	1.00 V	219	29.1	3.1
7	#7206.00	57.6 PK	74.0	-16.4	2.17 V	226	47.9	9.7
8	#7206.00	49.5 AV	54.0	-4.5	2.17 V	226	39.8	9.7

REMARKS:

1. Emission Level(dBuV/m) = Raw Value(dBuV) + Correction Factor(dB/m)
2. Correction Factor(dB/m) = Antenna Factor(dB/m) + Cable Factor(dB) – Pre-Amplifier Factor(dB)
3. The other emission levels were very low against the limit.
4. Margin value = Emission Level – Limit value
5. " * ": Fundamental frequency.
6. " # ": The radiated frequency is out of the restricted band.

CHANNEL	TX Channel 19	DETECTOR FUNCTION	Peak (PK)
FREQUENCY RANGE	1GHz ~ 25GHz		Average (AV)

ANTENNA POLARITY & TEST DISTANCE: HORIZONTAL AT 3 M

NO.	FREQ. (MHz)	EMISSION LEVEL (dBuV/m)	LIMIT (dBuV/m)	MARGIN (dB)	ANTENNA HEIGHT (m)	TABLE ANGLE (Degree)	RAW VALUE (dBuV)	CORRECTION FACTOR (dB/m)
1	2390.00	54.6 PK	74.0	-19.4	1.65 H	82	55.6	-1.0
2	2390.00	41.5 AV	54.0	-12.5	1.65 H	82	42.5	-1.0
3	*2440.00	99.5 PK			1.65 H	82	100.9	-1.4
4	*2440.00	98.0 AV			1.65 H	82	99.4	-1.4
5	2483.50	54.0 PK	74.0	-20.0	1.65 H	82	55.2	-1.2
6	2483.50	41.9 AV	54.0	-12.1	1.65 H	82	43.1	-1.2
7	4880.00	41.2 PK	74.0	-32.8	2.21 H	197	37.9	3.3
8	4880.00	33.4 AV	54.0	-20.6	2.21 H	197	30.1	3.3
9	7320.00	55.3 PK	74.0	-18.7	1.66 H	197	45.3	10.0
10	7320.00	47.0 AV	54.0	-7.0	1.66 H	197	37.0	10.0

ANTENNA POLARITY & TEST DISTANCE: VERTICAL AT 3 M

NO.	FREQ. (MHz)	EMISSION LEVEL (dBuV/m)	LIMIT (dBuV/m)	MARGIN (dB)	ANTENNA HEIGHT (m)	TABLE ANGLE (Degree)	RAW VALUE (dBuV)	CORRECTION FACTOR (dB/m)
1	2390.00	55.1 PK	74.0	-18.9	1.00 V	200	56.1	-1.0
2	2390.00	43.3 AV	54.0	-10.7	1.00 V	200	44.3	-1.0
3	*2440.00	108.0 PK			1.00 V	200	109.4	-1.4
4	*2440.00	107.0 AV			1.00 V	200	108.4	-1.4
5	2483.50	54.5 PK	74.0	-19.5	1.00 V	200	55.7	-1.2
6	2483.50	43.7 AV	54.0	-10.3	1.00 V	200	44.9	-1.2
7	4880.00	41.1 PK	74.0	-32.9	1.01 V	221	37.8	3.3
8	4880.00	32.3 AV	54.0	-21.7	1.01 V	221	29.0	3.3
9	7320.00	58.2 PK	74.0	-15.8	2.20 V	226	48.2	10.0
10	7320.00	50.3 AV	54.0	-3.7	2.20 V	226	40.3	10.0

REMARKS:

1. Emission Level(dBuV/m) = Raw Value(dBuV) + Correction Factor(dB/m)
2. Correction Factor(dB/m) = Antenna Factor(dB/m) + Cable Factor(dB) – Pre-Amplifier Factor(dB)
3. The other emission levels were very low against the limit.
4. Margin value = Emission Level – Limit value
5. " * ": Fundamental frequency.

CHANNEL	TX Channel 39	DETECTOR FUNCTION	Peak (PK)
FREQUENCY RANGE	1GHz ~ 25GHz		Average (AV)

ANTENNA POLARITY & TEST DISTANCE: HORIZONTAL AT 3 M

NO.	FREQ. (MHz)	EMISSION LEVEL (dBuV/m)	LIMIT (dBuV/m)	MARGIN (dB)	ANTENNA HEIGHT (m)	TABLE ANGLE (Degree)	RAW VALUE (dBuV)	CORRECTION FACTOR (dB/m)
1	*2480.00	98.6 PK			1.69 H	78	99.9	-1.3
2	*2480.00	97.5 AV			1.69 H	78	98.8	-1.3
3	2483.50	55.0 PK	74.0	-19.0	1.69 H	78	56.2	-1.2
4	2483.50	42.9 AV	54.0	-11.1	1.69 H	78	44.1	-1.2
5	4960.00	40.8 PK	74.0	-33.2	2.27 H	204	37.3	3.5
6	4960.00	33.0 AV	54.0	-21.0	2.27 H	204	29.5	3.5
7	7440.00	54.9 PK	74.0	-19.1	1.70 H	187	44.8	10.1
8	7440.00	46.6 AV	54.0	-7.4	1.70 H	187	36.5	10.1

ANTENNA POLARITY & TEST DISTANCE: VERTICAL AT 3 M

NO.	FREQ. (MHz)	EMISSION LEVEL (dBuV/m)	LIMIT (dBuV/m)	MARGIN (dB)	ANTENNA HEIGHT (m)	TABLE ANGLE (Degree)	RAW VALUE (dBuV)	CORRECTION FACTOR (dB/m)
1	*2480.00	107.1 PK			1.00 V	196	108.4	-1.3
2	*2480.00	106.5 AV			1.00 V	196	107.8	-1.3
3	2483.50	55.5 PK	74.0	-18.5	1.00 V	196	56.7	-1.2
4	2483.50	44.7 AV	54.0	-9.3	1.00 V	196	45.9	-1.2
5	4960.00	40.8 PK	74.0	-33.2	1.01 V	229	37.3	3.5
6	4960.00	32.2 AV	54.0	-21.8	1.01 V	229	28.7	3.5
7	7440.00	58.0 PK	74.0	-16.0	2.18 V	232	47.9	10.1
8	7440.00	49.9 AV	54.0	-4.1	2.18 V	232	39.8	10.1

REMARKS:

1. Emission Level(dBuV/m) = Raw Value(dBuV) + Correction Factor(dB/m)
2. Correction Factor(dB/m) = Antenna Factor(dB/m) + Cable Factor(dB) – Pre-Amplifier Factor(dB)
3. The other emission levels were very low against the limit.
4. Margin value = Emission Level – Limit value
5. " * ": Fundamental frequency.

Below 1GHz Data:

CHANNEL	TX Channel 39	DETECTOR FUNCTION	Quasi-Peak (QP)
FREQUENCY RANGE	9kHz ~ 1GHz		

ANTENNA POLARITY & TEST DISTANCE: HORIZONTAL AT 3 M

NO.	FREQ. (MHz)	EMISSION LEVEL (dBuV/m)	LIMIT (dBuV/m)	MARGIN (dB)	ANTENNA HEIGHT (m)	TABLE ANGLE (Degree)	RAW VALUE (dBuV)	CORRECTION FACTOR (dB/m)
1	32.28	29.7 QP	40.0	-10.3	1.50 H	9	38.6	-8.9
2	216.46	19.8 QP	46.0	-26.2	1.50 H	88	31.1	-11.3
3	370.71	22.1 QP	46.0	-23.9	1.00 H	200	27.3	-5.2
4	600.63	26.4 QP	46.0	-19.6	1.50 H	105	26.1	0.3
5	848.83	30.3 QP	46.0	-15.7	1.00 H	253	26.6	3.7
6	963.48	31.7 QP	54.0	-22.3	2.00 H	60	26.6	5.1

ANTENNA POLARITY & TEST DISTANCE: VERTICAL AT 3 M

NO.	FREQ. (MHz)	EMISSION LEVEL (dBuV/m)	LIMIT (dBuV/m)	MARGIN (dB)	ANTENNA HEIGHT (m)	TABLE ANGLE (Degree)	RAW VALUE (dBuV)	CORRECTION FACTOR (dB/m)
1	36.91	36.4 QP	40.0	-3.6	1.00 V	149	45.0	-8.6
2	85.90	31.0 QP	40.0	-9.0	3.00 V	247	44.6	-13.6
3	366.59	22.1 QP	46.0	-23.9	3.00 V	2	27.5	-5.4
4	532.56	26.0 QP	46.0	-20.0	1.00 V	307	27.6	-1.6
5	641.63	28.2 QP	46.0	-17.8	1.00 V	0	27.4	0.8
6	907.24	32.3 QP	46.0	-13.7	3.00 V	327	27.7	4.6

REMARKS:

1. Emission Level(dBuV/m) = Raw Value(dBuV) + Correction Factor(dB/m)
2. Correction Factor(dB/m) = Antenna Factor(dB/m) + Cable Factor(dB) – Pre-Amplifier Factor(dB)
3. The other emission levels were very low against the limit.
4. Margin value = Emission Level – Limit value

4.2 Conducted Emission Measurement

4.2.1 Limits of Conducted Emission Measurement

Frequency (MHz)	Conducted Limit (dBuV)	
	Quasi-peak	Average
0.15 - 0.5	66 - 56	56 - 46
0.50 - 5.0	56	46
5.0 - 30.0	60	50

Note: 1. The lower limit shall apply at the transition frequencies.

2. The limit decreases in line with the logarithm of the frequency in the range of 0.15 to 0.50MHz.

4.2.2 Test Instruments

DESCRIPTION & MANUFACTURER	MODEL NO.	SERIAL NO.	CALIBRATED DATE	CALIBRATED UNTIL
Test Receiver R&S	ESCS 30	847124/029	Nov. 01, 2017	Oct. 31, 2018
Line-Impedance Stabilization Network (for EUT) R&S	ESH3-Z5	848773/004	Nov. 15, 20167	Nov. 14, 2018
Line-Impedance Stabilization Network (for Peripheral) R&S	ENV216	100072	June 03, 2017	June 02, 2018
50 ohms Terminator	N/A	EMC-02	Sep. 22, 2017	Sep. 21, 2018
RF Cable	5D-FB	COCCAB-001	Sep. 29, 2017	Sep. 28, 2018
10 dB PAD Mini-Circuits	HAT-10+	CONATT-004	June 18, 2017	June 17, 2018
Software BVADT	BVADT_Cond_ V7.3.7.4	NA	NA	NA

Note:

1. The calibration interval of the above test instruments are 12 months and the calibrations are traceable to NML/ROC and NIST/USA.
2. The test was performed in Shielded Room No. 1.
3. Tested Date: Dec. 21 to 22, 2017

4.2.3 Test Procedures

- The EUT was placed 0.4 meters from the conducting wall of the shielded room with EUT being connected to the power mains through a line impedance stabilization network (LISN). Other support units were connected to the power mains through another LISN. The two LISNs provide 50 ohm/ 50uH of coupling impedance for the measuring instrument.
- Both lines of the power mains connected to the EUT were checked for maximum conducted interference.
- The frequency range from 150kHz to 30MHz was searched. Emission levels under (Limit - 20dB) was not recorded.

NOTE: The resolution bandwidth and video bandwidth of test receiver is 9kHz for quasi-peak detection (QP) and average detection (AV) at frequency 0.15MHz-30MHz.

4.2.4 Deviation from Test Standard

No deviation.

4.2.5 Test Setup

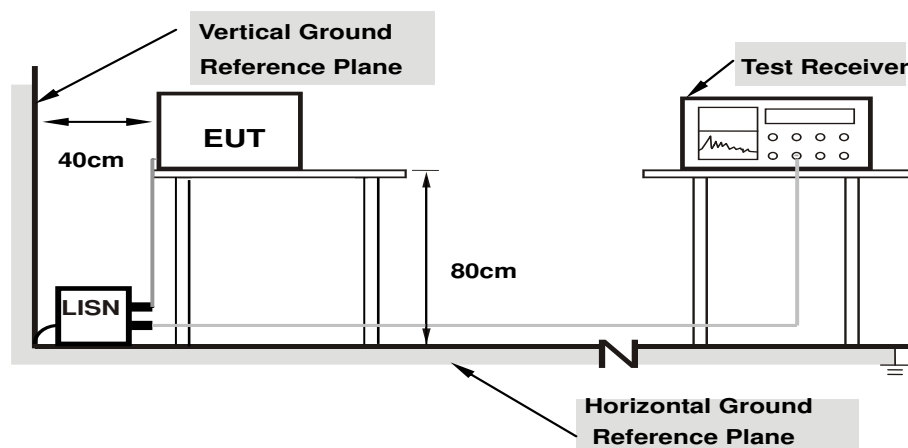

Note: 1.Support units were connected to second LISN.

For the actual test configuration, please refer to the attached file (Test Setup Photo).

4.2.6 EUT Operating Conditions

Same as 4.1.6.

4.2.7 Test Results (Mode 1)

Phase	Line (L)	Detector Function	Quasi-Peak (QP) / Average (AV)
-------	----------	-------------------	--------------------------------

No	Freq. [MHz]	Corr.	Reading Value		Emission Level		Limit		Margin	
		Factor (dB)	[dB (uV)]		[dB (uV)]		[dB (uV)]		(dB)	
		Q.P.	AV.	Q.P.	AV.	Q.P.	AV.	Q.P.	AV.	
1	0.15000	10.09	40.14	26.17	50.23	36.26	66.00	56.00	-15.77	-19.74
2	0.20469	10.07	29.18	18.20	39.25	28.27	63.42	53.42	-24.17	-25.15
3	0.40781	10.12	30.09	26.61	40.21	36.73	57.69	47.69	-17.48	-10.96
4	0.90391	10.16	9.00	2.28	19.16	12.44	56.00	46.00	-36.84	-33.56
5	11.67578	10.93	14.45	9.43	25.38	20.36	60.00	50.00	-34.62	-29.64
6	20.70703	11.60	4.03	-1.02	15.63	10.58	60.00	50.00	-44.37	-39.42

REMARKS:

1. Q.P. and AV. are abbreviations of quasi-peak and average individually.
2. The emission levels of other frequencies were very low against the limit.
3. Margin value = Emission level - Limit value
4. Correction factor = Insertion loss + Cable loss
5. Emission Level = Correction Factor + Reading Value.

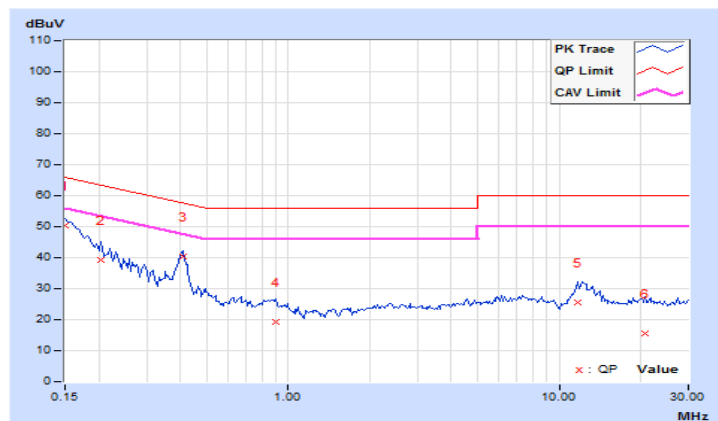

Phase	Neutral (N)	Detector Function	Quasi-Peak (QP) / Average (AV)
-------	-------------	-------------------	--------------------------------

No	Freq. [MHz]	Corr.	Reading Value		Emission Level		Limit		Margin	
		Factor	[dB (uV)]		[dB (uV)]		[dB (uV)]		(dB)	
		(dB)	Q.P.	AV.	Q.P.	AV.	Q.P.	AV.	Q.P.	AV.
1	0.15781	10.07	38.72	23.58	48.79	33.65	65.58	55.58	-16.79	-21.93
2	0.19297	10.04	30.87	16.54	40.91	26.58	63.91	53.91	-23.00	-27.33
3	0.22812	10.05	25.72	14.77	35.77	24.82	62.52	52.52	-26.75	-27.70
4	0.40000	10.12	24.46	20.47	34.58	30.59	57.85	47.85	-23.27	-17.26
5	2.01953	10.21	11.91	4.61	22.12	14.82	56.00	46.00	-33.88	-31.18
6	11.89063	10.82	18.52	13.46	29.34	24.28	60.00	50.00	-30.66	-25.72

REMARKS:

1. Q.P. and AV. are abbreviations of quasi-peak and average individually.
2. The emission levels of other frequencies were very low against the limit.
3. Margin value = Emission level - Limit value
4. Correction factor = Insertion loss + Cable loss
5. Emission Level = Correction Factor + Reading Value.

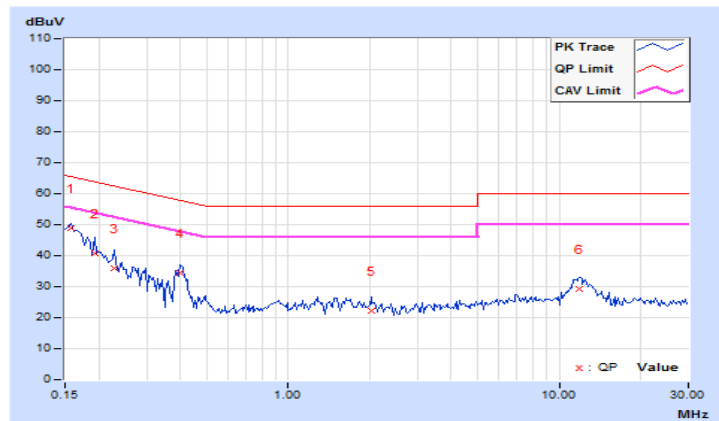

4.2.8 Test Results (Mode 2)

Phase	Line (L)	Detector Function	Quasi-Peak (QP) / Average (AV)
-------	----------	-------------------	--------------------------------

No	Freq. [MHz]	Corr. Factor	Reading Value [dB (uV)]		Emission Level [dB (uV)]		Limit [dB (uV)]		Margin (dB)	
		(dB)	Q.P.	AV.	Q.P.	AV.	Q.P.	AV.	Q.P.	AV.
	1	0.15000	10.09	41.99	27.34	52.08	37.43	66.00	56.00	-13.92
2	0.22422	10.08	27.97	16.78	38.05	26.86	62.66	52.66	-24.61	-25.80
3	0.25547	10.08	26.18	16.07	36.26	26.15	61.58	51.58	-25.32	-25.43
4	0.41172	10.12	30.18	27.63	40.30	37.75	57.61	47.61	-17.31	-9.86
5	6.92188	10.57	12.63	7.52	23.20	18.09	60.00	50.00	-36.80	-31.91
6	12.44922	10.99	17.22	12.39	28.21	23.38	60.00	50.00	-31.79	-26.62

REMARKS:

1. Q.P. and AV. are abbreviations of quasi-peak and average individually.
2. The emission levels of other frequencies were very low against the limit.
3. Margin value = Emission level - Limit value
4. Correction factor = Insertion loss + Cable loss
5. Emission Level = Correction Factor + Reading Value.

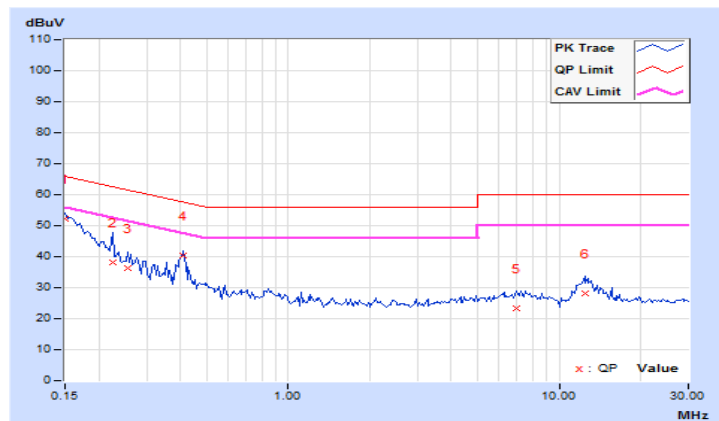

Phase	Neutral (N)	Detector Function	Quasi-Peak (QP) / Average (AV)
-------	-------------	-------------------	--------------------------------

No	Freq. [MHz]	Corr.	Reading Value		Emission Level		Limit		Margin	
		Factor	[dB (uV)]		[dB (uV)]		[dB (uV)]		(dB)	
		(dB)	Q.P.	AV.	Q.P.	AV.	Q.P.	AV.	Q.P.	AV.
1	0.15000	10.08	41.76	27.46	51.84	37.54	66.00	56.00	-14.16	-18.46
2	0.19297	10.04	33.17	20.01	43.21	30.05	63.91	53.91	-20.70	-23.86
3	0.29844	10.08	26.94	20.72	37.02	30.80	60.29	50.29	-23.27	-19.49
4	0.40781	10.12	32.99	32.18	43.11	42.30	57.69	47.69	-14.58	-5.39
5	0.87266	10.13	13.96	7.99	24.09	18.12	56.00	46.00	-31.91	-27.88
6	12.76563	10.88	14.84	10.11	25.72	20.99	60.00	50.00	-34.28	-29.01

REMARKS:

1. Q.P. and AV. are abbreviations of quasi-peak and average individually.
2. The emission levels of other frequencies were very low against the limit.
3. Margin value = Emission level - Limit value
4. Correction factor = Insertion loss + Cable loss
5. Emission Level = Correction Factor + Reading Value.

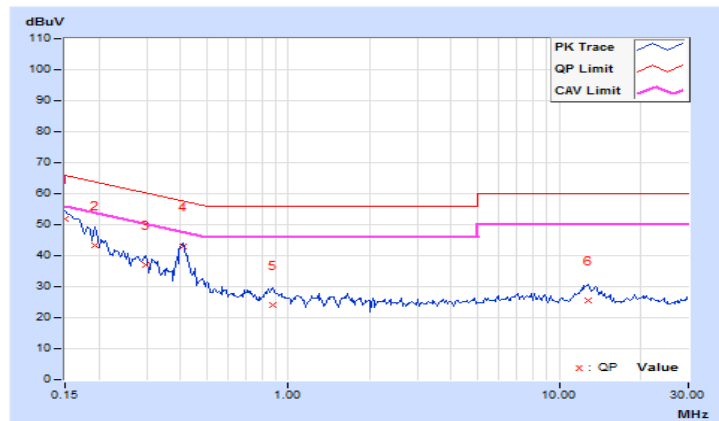

4.2.9 Test Results (Mode 3)

Phase	Line (L)	Detector Function	Quasi-Peak (QP) / Average (AV)
-------	----------	-------------------	--------------------------------

No	Freq. [MHz]	Corr.	Reading Value		Emission Level		Limit		Margin	
		Factor	[dB (uV)]		[dB (uV)]		[dB (uV)]		(dB)	
	(dB)	Q.P.	AV.	Q.P.	AV.	Q.P.	AV.	Q.P.	AV.	
1	0.15000	10.09	44.63	28.74	54.72	38.83	66.00	56.00	-11.28	-17.17
2	0.16562	10.08	42.13	26.74	52.21	36.82	65.18	55.18	-12.97	-18.36
3	0.19687	10.07	37.42	24.50	47.49	34.57	63.74	53.74	-16.25	-19.17
4	0.42344	10.12	38.08	30.98	48.20	41.10	57.38	47.38	-9.18	-6.28
5	0.54844	10.13	24.49	15.34	34.62	25.47	56.00	46.00	-21.38	-20.53
6	15.97266	11.28	30.81	25.19	42.09	36.47	60.00	50.00	-17.91	-13.53

REMARKS:

1. Q.P. and AV. are abbreviations of quasi-peak and average individually.
2. The emission levels of other frequencies were very low against the limit.
3. Margin value = Emission level - Limit value
4. Correction factor = Insertion loss + Cable loss
5. Emission Level = Correction Factor + Reading Value.

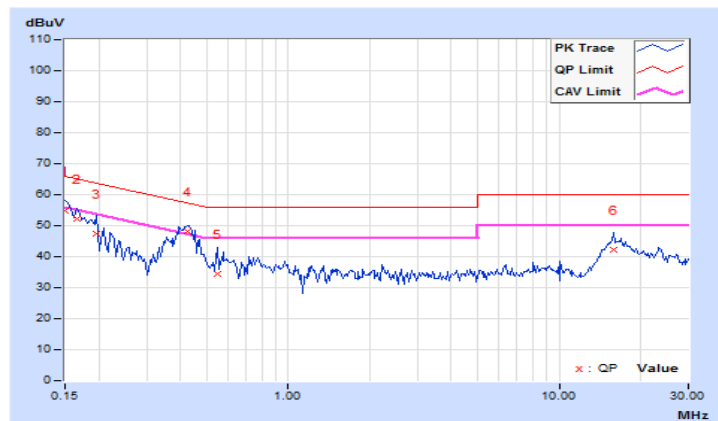

Phase	Neutral (N)	Detector Function	Quasi-Peak (QP) / Average (AV)
-------	-------------	-------------------	--------------------------------

No	Freq. [MHz]	Corr.	Reading Value		Emission Level		Limit		Margin	
		Factor (dB)	[dB (uV)]		[dB (uV)]		[dB (uV)]		(dB)	
			Q.P.	AV.	Q.P.	AV.	Q.P.	AV.	Q.P.	AV.
1	0.15391	10.07	44.32	28.88	54.39	38.95	65.79	55.79	-11.40	-16.84
2	0.18516	10.05	39.26	24.86	49.31	34.91	64.25	54.25	-14.94	-19.34
3	0.34922	10.10	32.04	22.48	42.14	32.58	58.98	48.98	-16.84	-16.40
4	0.42344	10.12	40.00	32.45	50.12	42.57	57.38	47.38	-7.26	-4.81
5	15.72266	11.05	31.18	25.67	42.23	36.72	60.00	50.00	-17.77	-13.28
6	24.54297	11.28	25.24	19.87	36.52	31.15	60.00	50.00	-23.48	-18.85

REMARKS:

1. Q.P. and AV. are abbreviations of quasi-peak and average individually.
2. The emission levels of other frequencies were very low against the limit.
3. Margin value = Emission level - Limit value
4. Correction factor = Insertion loss + Cable loss
5. Emission Level = Correction Factor + Reading Value.

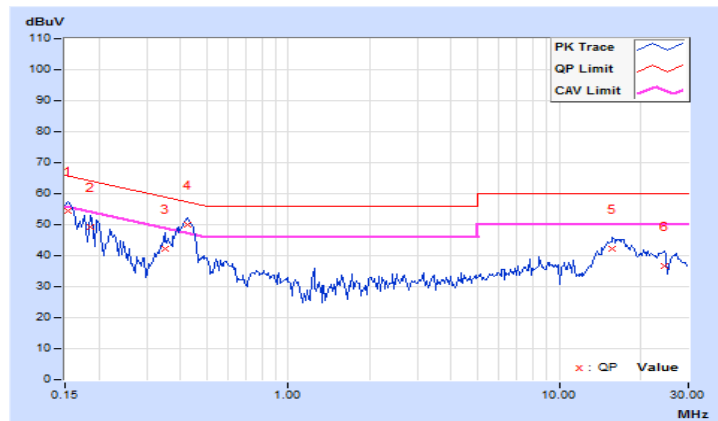

4.2.10 Test Results (Mode 4)

Phase	Line (L)	Detector Function	Quasi-Peak (QP) / Average (AV)
-------	----------	-------------------	--------------------------------

No	Freq. [MHz]	Corr.	Reading Value		Emission Level		Limit		Margin	
		Factor	[dB (uV)]		[dB (uV)]		[dB (uV)]		(dB)	
	(dB)	Q.P.	AV.	Q.P.	AV.	Q.P.	AV.	Q.P.	AV.	
1	0.15000	10.09	43.94	27.58	54.03	37.67	66.00	56.00	-11.97	-18.33
2	0.20078	10.07	36.27	21.34	46.34	31.41	63.58	53.58	-17.24	-22.17
3	0.43516	10.12	36.55	29.10	46.67	39.22	57.15	47.15	-10.48	-7.93
4	0.57578	10.13	25.02	16.40	35.15	26.53	56.00	46.00	-20.85	-19.47
5	1.93750	10.17	21.04	13.28	31.21	23.45	56.00	46.00	-24.79	-22.55
6	15.81250	11.26	28.30	22.86	39.56	34.12	60.00	50.00	-20.44	-15.88

REMARKS:

1. Q.P. and AV. are abbreviations of quasi-peak and average individually.
2. The emission levels of other frequencies were very low against the limit.
3. Margin value = Emission level - Limit value
4. Correction factor = Insertion loss + Cable loss
5. Emission Level = Correction Factor + Reading Value.

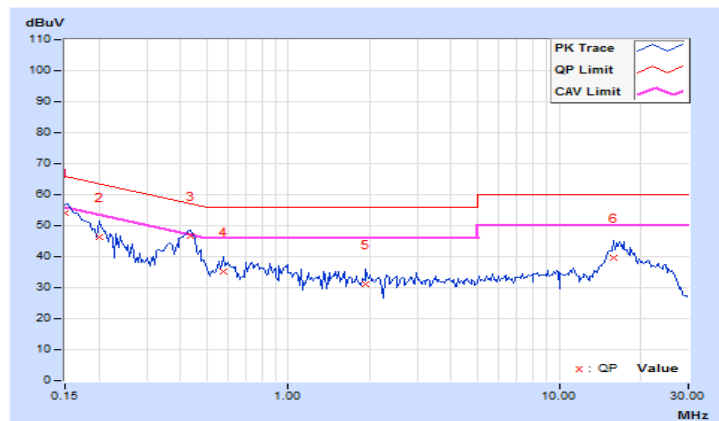

Phase	Neutral (N)	Detector Function	Quasi-Peak (QP) / Average (AV)
-------	-------------	-------------------	--------------------------------

No	Freq. [MHz]	Corr.	Reading Value		Emission Level		Limit		Margin	
		Factor	[dB (uV)]		[dB (uV)]		[dB (uV)]		(dB)	
		(dB)	Q.P.	AV.	Q.P.	AV.	Q.P.	AV.	Q.P.	AV.
1	0.15000	10.08	43.98	29.11	54.06	39.19	66.00	56.00	-11.94	-16.81
2	0.18125	10.05	39.27	26.50	49.32	36.55	64.43	54.43	-15.11	-17.88
3	0.21250	10.05	35.53	23.07	45.58	33.12	63.11	53.11	-17.53	-19.99
4	0.43516	10.12	38.89	31.51	49.01	41.63	57.15	47.15	-8.14	-5.52
5	0.55625	10.12	23.16	11.29	33.28	21.41	56.00	46.00	-22.72	-24.59
6	17.13281	11.13	29.38	23.83	40.51	34.96	60.00	50.00	-19.49	-15.04

REMARKS:

1. Q.P. and AV. are abbreviations of quasi-peak and average individually.
2. The emission levels of other frequencies were very low against the limit.
3. Margin value = Emission level - Limit value
4. Correction factor = Insertion loss + Cable loss
5. Emission Level = Correction Factor + Reading Value.

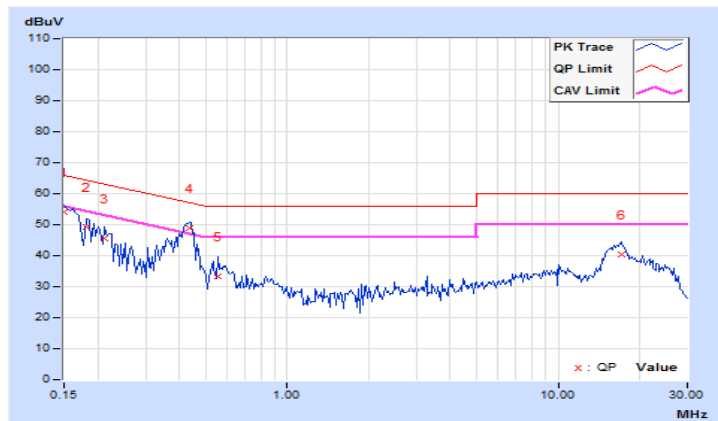

4.3 6dB Bandwidth Measurement

4.3.1 Limits of 6dB Bandwidth Measurement

The minimum of 6dB Bandwidth Measurement is 0.5 MHz.

4.3.2 Test Setup

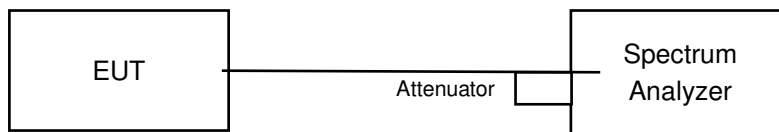

4.3.3 Test Instruments

Refer to section 4.1.2 to get information of above instrument.

4.3.4 Test Procedure

- a. Set resolution bandwidth (RBW) = 100kHz
- b. Set the video bandwidth (VBW) $\geq 3 \times$ RBW, Detector = Peak.
- c. Trace mode = max hold.
- d. Sweep = auto couple.
- e. Measure the maximum width of the emission that is constrained by the frequencies associated with the two amplitude points (upper and lower) that are attenuated by 6 dB relative to the maximum level measured in the fundamental emission

4.3.5 Deviation from Test Standard

No deviation.

4.3.6 EUT Operating Conditions

The software provided by client to enable the EUT under transmission condition continuously at lowest, middle and highest channel frequencies individually.

4.3.7 Test Result

Channel	Frequency (MHz)	6dB Bandwidth (MHz)	Minimum Limit (MHz)	Pass / Fail
0	2402	0.70	0.5	Pass
19	2440	0.71	0.5	Pass
39	2480	0.72	0.5	Pass

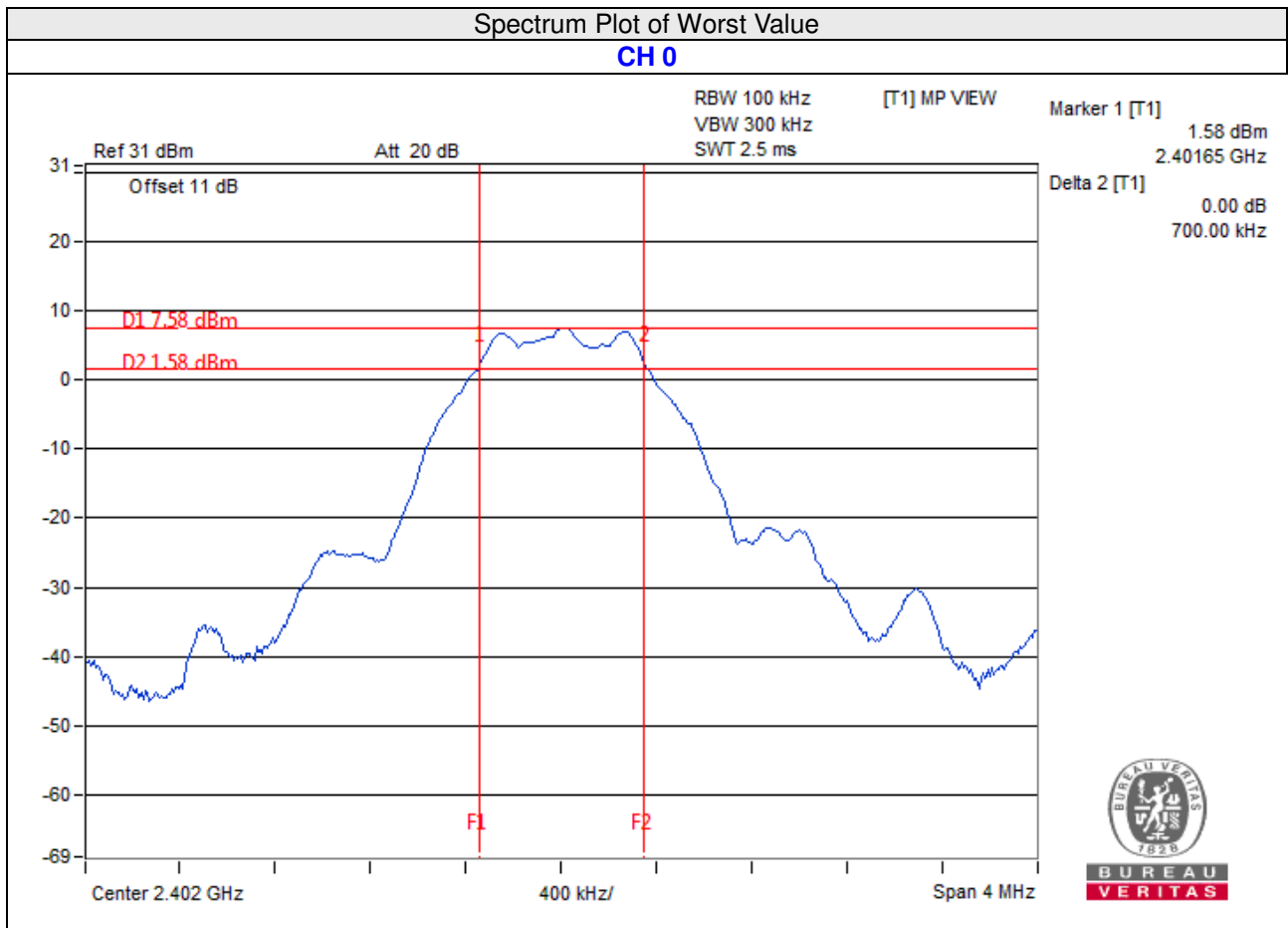

4.4 Conducted Output Power Measurement

4.4.1 Limits of Conducted Output Power Measurement

For systems using digital modulation in the 2400–2483.5 MHz bands: 1 Watt (30dBm)

4.4.2 Test Setup

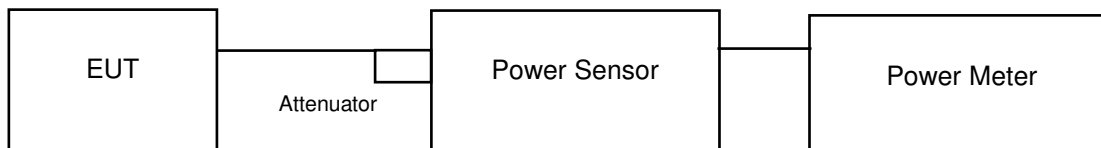

4.4.3 Test Instruments

Refer to section 4.1.2 to get information of above instrument.

4.4.4 Test Procedures

A peak / average power sensor was used on the output port of the EUT. A power meter was used to read the response of the peak / average power sensor. Record the power level.

4.4.5 Deviation from Test Standard

No deviation.

4.4.6 EUT Operating Conditions

Same as Item 4.3.6.

4.4.7 Test Results

FOR PEAK POWER

Channel	Frequency (MHz)	Peak Power (mW)	Peak Power (dBm)	Limit (dBm)	Pass/Fail
0	2402	6.561	8.17	30	Pass
19	2440	7.43	8.71	30	Pass
39	2480	8.241	9.16	30	Pass

FOR AVERAGE POWER

Channel	Frequency (MHz)	Average Power (mW)	Average Power (dBm)
0	2402	6.223	7.94
19	2440	7.079	8.50
39	2480	8.11	9.09

4.5 Power Spectral Density Measurement

4.5.1 Limits of Power Spectral Density Measurement

The Maximum of Power Spectral Density Measurement is 8dBm.

4.5.2 Test Setup

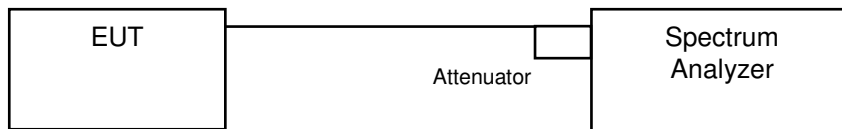

4.5.3 Test Instruments

Refer to section 4.1.2 to get information of above instrument.

4.5.4 Test Procedure

- a. Set analyzer center frequency to DTS channel center frequency.
- b. Set the span to 1.5 times the DTS bandwidth.
- c. Set the RBW to: $3 \text{ kHz} \leq \text{RBW} \leq 100 \text{ kHz}$.
- d. Set the VBW $\geq 3 \times \text{RBW}$.
- e. Detector = peak.
- f. Sweep time = auto couple.
- g. Trace mode = max hold.
- h. Allow trace to fully stabilize.
- i. Use the peak marker function to determine the maximum amplitude level within the RBW.

4.5.5 Deviation from Test Standard

No deviation.

4.5.6 EUT Operating Condition

Same as Item 4.3.6

4.5.7 Test Results

Channel	Freq. (MHz)	PSD (dBm/3kHz)	Limit (dBm/3kHz)	Pass /Fail
0	2402	-8.05	8	Pass
19	2440	-6.01	8	Pass
39	2480	-6.97	8	Pass

Spectrum Plot of Worst Value

CH19

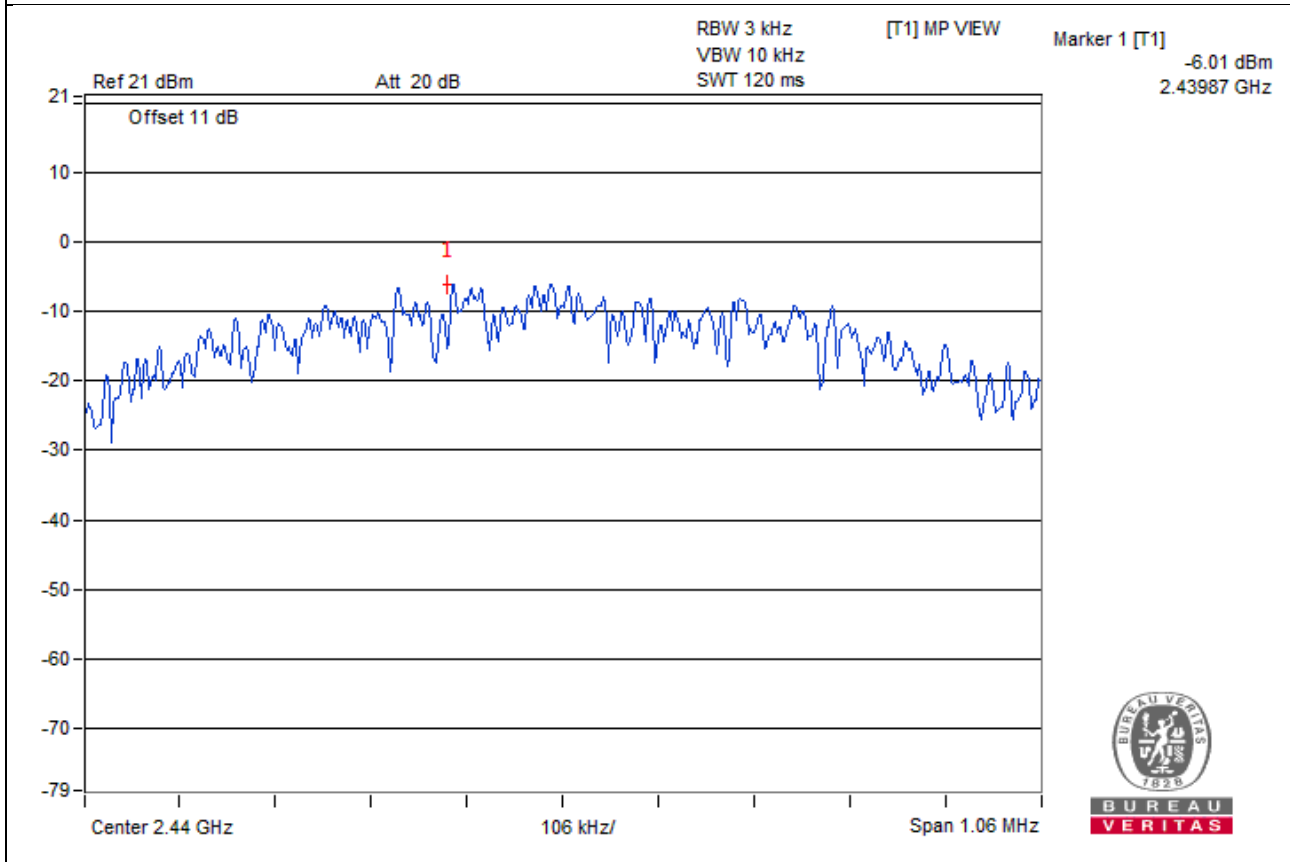

4.6 Conducted Out of Band Emission Measurement

4.6.1 Limits of Conducted Out of Band Emission Measurement

Below -20dB of the highest emission level of operating band (in 100kHz Resolution Bandwidth).

4.6.2 Test Setup

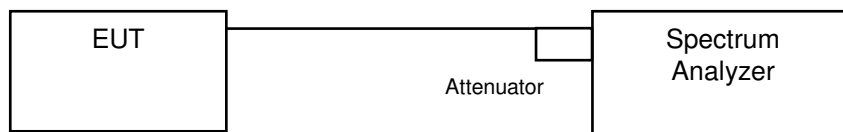

4.6.3 Test Instruments

Refer to section 4.1.2 to get information of above instrument.

4.6.4 Test Procedure

MEASUREMENT PROCEDURE REF

1. Set the RBW = 100 kHz.
2. Set the VBW \geq 300 kHz.
3. Detector = peak.
4. Sweep time = auto couple.
5. Trace mode = max hold.
6. Allow trace to fully stabilize.
7. Use the peak marker function to determine the maximum power level in any 100 kHz band segment within the fundamental EBW.

MEASUREMENT PROCEDURE OOB

1. Set RBW = 100 kHz.
2. Set VBW \geq 300 kHz.
3. Detector = peak.
4. Sweep = auto couple.
5. Trace Mode = max hold.
6. Allow trace to fully stabilize.
7. Use the peak marker function to determine the maximum amplitude level.

4.6.5 Deviation from Test Standard

No deviation.

4.6.6 EUT Operating Condition

Same as Item 4.3.6

4.6.7 Test Results

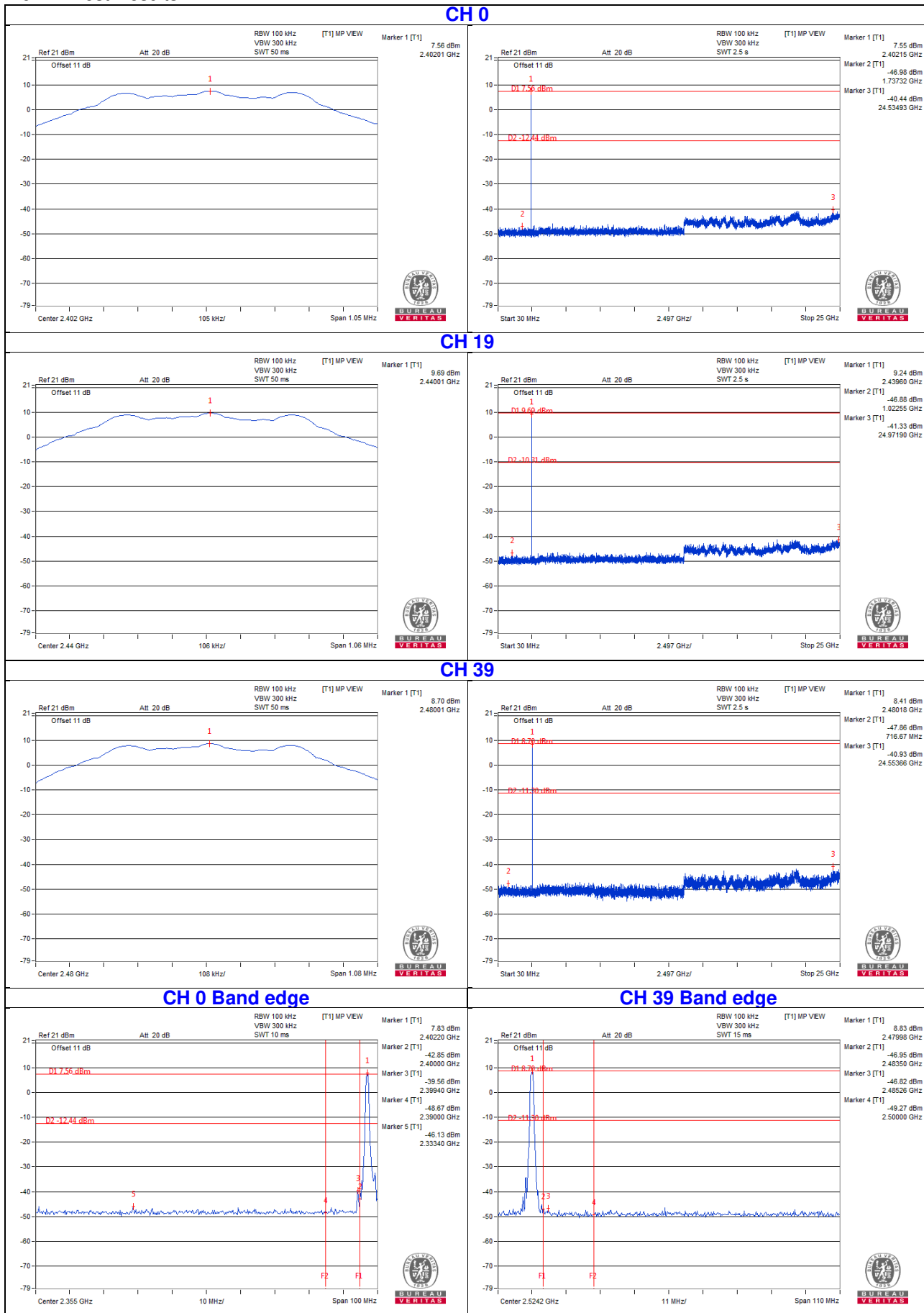

5 Pictures of Test Arrangements

Please refer to the attached file (Test Setup Photo).

Appendix – Information on the Testing Laboratories

We, Bureau Veritas Consumer Products Services (H.K.) Ltd., Taoyuan Branch, were founded in 1988 to provide our best service in EMC, Radio, Telecom and Safety consultation. Our laboratories are FCC recognized accredited test firms and accredited according to ISO/IEC 17025.

If you have any comments, please feel free to contact us at the following:

Linkou EMC/RF Lab

Tel: 886-2-26052180

Fax: 886-2-26051924

Hsin Chu EMC/RF/Telecom Lab

Tel: 886-3-6668565

Fax: 886-3-6668323

Hwa Ya EMC/RF/Safety Lab

Tel: 886-3-3183232

Fax: 886-3-3270892

Email: service.adt@tw.bureauveritas.com

Web Site: www.bureauveritas-adt.com

The address and road map of all our labs can be found in our web site also.

--- END ---