



nanoCell

Operations and Installation Manual

TW-03-300-1010

9 June 2003

Telephonics Wireless Corporation
2290 W. Eau Gallie Blvd. Suite 110
Melbourne, Florida 32935 USA
Phone 321-757-6336 • Fax 321-757-7394

This document constitutes an unpublished work under the copyright laws. It is submitted in confidence and contains proprietary and confidential information. All information is subject to change without notice. The contents of this document may not be reproduced, transmitted or used without express written authority. The copyright and the foregoing restriction on reproduction, transmission and use extend to all media in which the information may be embodied.

TABLE OF CONTENTS

1	Introduction and General Information.....	1
1.1	Introduction	1
1.1.1	Purpose of Manual.....	1
1.1.2	Manual Arrangement.....	1
1.1.3	Warnings, Cautions, and Notes	1
1.1.4	Related Publications	1
1.1.5	List Of Abbreviations and Acronyms.....	2
1.2	FCC Notice.....	3
1.2.1	United States Federal Communications Commission Required User Information .	3
1.2.2	Industry Canada Required User Information, Canadian Notice (Avis Canadien)...	3
1.3	General Information	4
1.4	System Description.....	4
1.4.1	System Operation	4
1.4.2	Leading Particulars.....	5
1.4.3	Antennas.....	6
1.4.4	NanoCell.....	6
1.5	Operational Overview	6
2	Tools and Test Equipment.....	9
2.1	General	9
2.2	Equipment Required and Supplied.....	9
2.3	Equipment Required but not Supplied.....	9
2.4	Equipment Recommended but not Supplied	9
3	System Installation	10
3.1	Antenna Assembly.....	10
3.1.1	Antenna	10
3.1.2	Cabling	10
3.1.3	Grounding.....	10
3.2	nanoCell Assembly.....	10
3.2.1	Unpacking the nanoCell	10
3.2.2	Mounting the nanoCell.....	11
3.2.3	nanoCell Grounding	13
3.2.4	Power Application.....	13
3.2.5	Cabling	14
4	System Commissioning.....	15
4.1	Power-up	15
4.2	System Start-up	15

4.3	System Provisioning.....	16
5	Installation Test and Final Acceptance.....	19
5.1	Power-up	19
5.2	Start-up	19
5.3	System Configuration.....	19
5.4	Field Acceptance Test	20
6	Return Materials Authorization.....	21

LIST OF FIGURES

Figure 1. nanoCell Operational Concept.....	4
Figure 2. nanoCell Functional Diagram.....	5
Figure 3. nanoCell Start-up	7
Figure 4. Pole Mount of the nanoCell	12
Figure 5. Detailed nanoCell Mounting Diagram.....	13
Figure 6. nanoCell Grounding Tie-in Point.....	13
Figure 7. Power Connections	14
Figure 8. Antenna Connections	15
Figure 9. LMT Opening Screen.....	17
Figure 10. Properties Dialog Box.....	17
Figure 11. System Parameters Dialog Box.....	18
Figure 12. LMT Opening Screen.....	19
Figure 13. System Parameters Dialog Box.....	20

LIST OF TABLES

Table 1-1. Related Publications.....	1
Table 1-2. Leading Particulars	6
Table 2-1. Equipment Required and Supplied.....	9
Table 2-2. Equipment Recommended but not Supplied.....	9
Table 2-3. Equipment Required but not Supplied	9
Table 5-1. Field Acceptance Tests	20

NOTICE

This document describes a GSM cellular communications device that is currently under development. While every effort has been made to ensure accuracy and completeness of the data and descriptive text in this document, Telephonics Wireless Corporation reserves the right to change the product specifications, features, and/or functions at any time and without notice.

This Page Intentionally Left Blank

1 Introduction and General Information

1.1 Introduction

1.1.1 Purpose of Manual

The purpose of this manual is to provide the installer with the knowledge and information necessary to install, configure, and provision the nanoCell for operation.

1.1.2 Manual Arrangement

This manual consists of and is arranged as follows:

Chapter	Title
1.	Introduction and General Information
2.	Tools and Test Equipment
3.	System Installation
4.	System Configuration
5.	Installation Test and Final Acceptance

1.1.3 Warnings, Cautions, and Notes

Warnings, cautions, and notes precede the text to which each applies. Warnings, cautions, and notes that appear in this manual are defined as follows:



Warning

An installation or operating procedure, practice, condition, statement, etc., which if not strictly observed, could result in damage to, or destruction of equipment or injury to personnel.



Caution

An installation or operating procedure, practice, condition, statement, etc., which if not strictly observed, could result in damage to, or destruction of equipment.

NOTE



Note

An essential installation or operating procedure, condition, or statement that must be highlighted.

1.1.4 Related Publications

Table 1-1 contains the technical publications related to the nanoCell.

Table 1-1. Related Publications

Publication Number	Title	Applicability
	Site Installation Work Sheet	System Installation
SZ 2584	Mounting Kit Data Sheet	nanoCell mounting
	LMT Operations Manual	LMT Operations

1.1.5 List Of Abbreviations and Acronyms

Terminology and abbreviations used in this document are listed below:

AMSL	Above Mean Sea Level
ARFCN	Absolute Radio Frequency Channel Number
BCCH	Broadcast Control CHannel
BCH	Broadcast CHannel
BOOTP	Bootstrap Protocol (defined in RFC 951)
BSC	Base Station Controller, a network element that controls the BTSs
BTS	Base Transceiver Station, the network element that provides radio communications capabilities.
C	(temperature) Centigrade
dB	decibels
E1	A digital trunk specification for 2048 kbps communication links used outside of North America
ETSI	European Telecommunications Standards Institute, the standards body responsible for GSM standards
GPS	Global Positioning Satellite
GSM	Global System for Mobile communications
HO	HandOver
ID	IDentification (number)
LED	Light Emitting Diode
LMT	Local Maintenance Terminal
MCC	Mobile Country Code
MHz	Mega (million) hertz
MNC	Mobile Network Code
MS	Mobile Station, the “cellular telephone”
MSC	Mobile Switching Center, a network element providing call completion and interconnection
nBTS	nanoBTS, a subsystem of the nanoCell
nMS	nanoMS, a subsystem of the nanoCell
nTAP	acronym for a device which gathers encryption data from the A Link
PAGCH	Paging and Access Grant CHannel
P	Power – used in the C1 computation
PDN	Public Data Network
PLMN	Public Land Mobile Network-the identity of the serving cellular carrier

List Of Abbreviations and Acronyms - continued

POST	Power On Self-Test
PSTN	Public Switched Telephone Network
RACH	Random Access CHannel
RF	Radio Frequency
ROM	Read Only Memory
SDCCH	Standalone Digital Control CHannel
SIM	Subscriber Information Module
SMS	Short Message Service
T1	A digital trunk specification for 1544 kbps communication links used in North America
TCH	Traffic Channel
VAC	Volts Alternating Current
VDC	Volts Direct Current

1.2 FCC Notice

1.2.1 United States Federal Communications Commission Required User Information

Class A Equipment

This equipment has been tested and found to comply with the limits for a Class A digital device, pursuant to Part 15 of the FCC rules. These limits are designed to provide reasonable protection against harmful interference when the equipment is operated in a commercial environment. This equipment generates, uses, and can radiate radio frequency energy and, if not installed and used in accordance with the instruction manual, may cause harmful interference to radio communications. Operation of this equipment in a residential area is likely to cause harmful interference, in which case the user will be required to correct the interference at his own expense.



Caution: The user that makes any changes or modifications not expressly approved by Telephonics Wireless Corporation for compliance could void the user's authority to operate the equipment.

1.2.2 Industry Canada Required User Information, Canadian Notice (Avis Canadian)

Class A Equipment

This Class A digital apparatus meets all requirements of the Canadian Interference-Causing Equipment Regulations. Cet appareil numérique de la classe A respecte toutes les exigences du Règlement sur le matériel brouilleur du Canada.

1.3 General Information

A nanoCell is a GSM cellular infrastructure device operating to ETSI communications standards, providing improved link performance in an existing GSM network. It extends the cellular network into areas with limited coverage and interference problems with no changes required in the GSM network or Mobile Stations (MSs). As shown in Figure 1, the nanoCell is capable of communicating with multiple network BTSs and will intelligently route mobile calls to the best network location capable of handling the call based on BTS loading and offered service capabilities. nanoCells operate in a typical GSM Network, connecting Mobile Stations to the Base Station best equipped to handle the call.

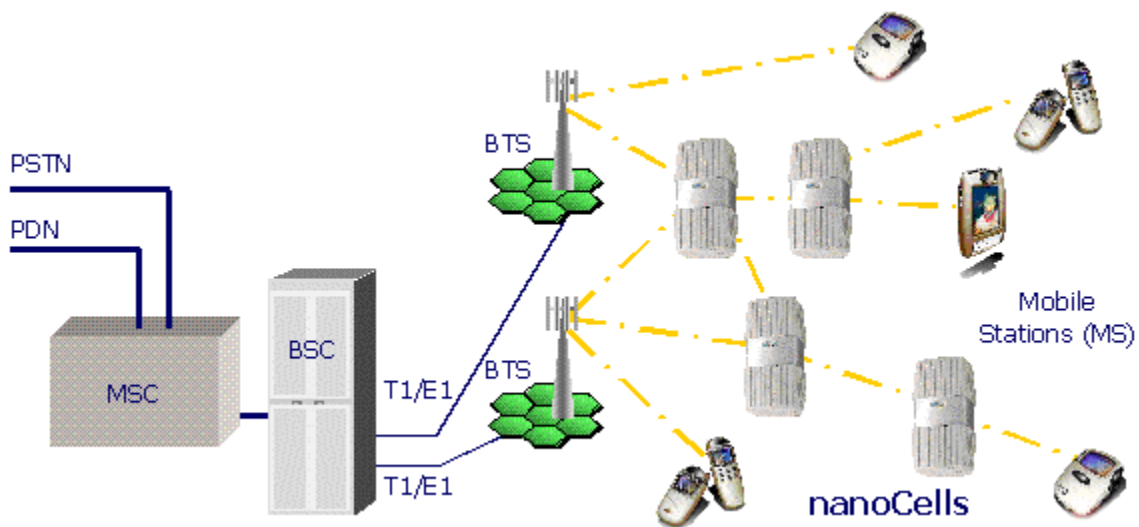

Figure 1. nanoCell Operational Concept

High spot traffic loads can be moved to other less-loaded base stations thereby increasing the utilization of overall system capacity.

The nanoCell uses the GSM air interface (Um) for backhaul to the network, creating a path in the same manner as a mobile station. Backhaul transmission to the network BTS occurs only when needed and there is no continuous transmission on the idle channels. Standard GSM protocols are observed and no changes are required of either the network or the mobile stations.

By constantly monitoring its radio environment, the nanoCell can rapidly adapt to changing conditions due to new network equipment, failures in the network, transient loading of Base Stations, and changing service capabilities of the network.

1.4 System Description

1.4.1 System Operation

The nanoCell contains a base station function (the nano Base Station, or nBTS) and a mobile station function (the nano Mobile Station, or nMS) as shown in Figure 2.

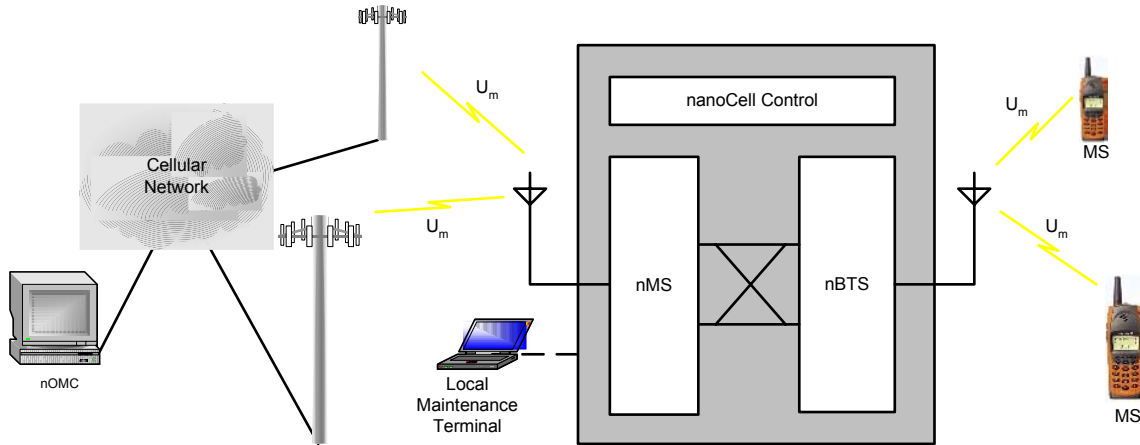

Figure 2. nanoCell Functional Diagram.

The nanoCell™ comprises multiple virtual mobile stations and base stations that interoperate within the air interface between network base stations, user mobile stations, and other nanoCells

The nMS subsystem acts as a mobile station, communicating with a network BTS or another nanoCell nBTS. It mimics the characteristics of the mobile station being served, including the identity of the served mobile station. To the network BTS, it appears that the served mobile station is connected directly.

The nBTS subsystem operates as a base station, including the transmission of control channels, paging and access messages, SDCCH, and traffic channels. To the served mobile station (or another nanoCell nMS subsystem), the nBTS appears to be a complete base station.

The nanoCell control function coordinates the nMS and nBTS subsystems to provide a path for uplink mobile access attempts, downlink paging message propagation, and cross connection of the traffic channels when a call has been set up.

The unit is self-contained, designed for indoor or outdoor mounting on pads, towers, poles, roofs, or walls with no additional enclosures, air conditioning or other support equipment required. The nanoCell is powered from 115 or 220 VAC single-phase, 50 – 60 Hertz, or –48 VDC.

The antennas are separate from the nanoCell assembly, allowing antenna placement to be engineered for higher link performance and a greater height than a typical mobile station. This provides a better overall communications path between the network BTS and the mobile station, reducing BTS and MS power requirements, while improving end to end channel performance. Antennas may be selected and placed for optimum operation with the specific characteristics required for the desired coverage patterns.

A Local Maintenance Terminal (LMT) supports field and depot operations. When necessary, this device connects directly to the nanoCell through an internal Ethernet port

1.4.2 Leading Particulars

Table 1-2 contains the leading particulars for the nanoCell.

Table 1-2. Leading Particulars

ITEM	SPECIFICATION	RANGE
1	Operating Voltage	115 or 220 VAC single-phase, 50 – 60 Hertz, or –48 VDC
2	Power Consumption	500 Watts (4x4 Configuration)
3	Weight	Approximately 180 pounds
4	Dimensions	23.6” W x 19.7” D X 27.5” H
5	Operating temperature	-30 deg C to +50 deg C
6	Storage temperature	-40 deg C to +85 deg C
7	Humidity	5 to 95%, non condensing
8	Altitude	-500 to +10,000 feet AMSL
9	Shock and vibration	Meets GR-47-CORE requirements
10	Wind	Meets GR-47-CORE requirements

1.4.3 Antennas

Antennas are mounted external to the nanoCell. Connections are brought out via N-type connectors through the mounting plate of the nanoCell. On the nMS subsystem, there are two connections, with four transceivers serving each of two antenna connections. On the nBTS subsystem, there is a single connection, with all four transceivers using the same antenna.

1.4.4 NanoCell

The nanoCell interfaces with an Installation Terminal, Mobile Stations and Base Stations and a local power source. The air interfaces to Base Stations and Mobile Stations adhere to the GSM standards so that no modifications are required within Mobile Stations or Base Stations in order to work with nanoCells. The interface to the Terminal is a standard ethernet connection. Power is supplied normally by a 110 volt AC power source. Operation with Mobile Stations is assured by creating within the nanoCell, a base station function. Referred to as a nano Base Station (nBTS), this function communicates with Mobile Stations in the same manner as an actual Base Station would. In a similar manner, operation with a Base Station is assured by creating within a nanoCell, a mobile station function. This nano mobile station (nMS) operates as any GSM Mobile Station and can communicate with a GSM Base Station in a manner identical to an actual phone.

1.5 Operational Overview

After proper execution of the Boot program, the nanoCell performs a cell selection process similar to that defined for mobile stations, refer to Figure 3. Active channels are identified during an RF Scan. A BTS Survey then begins to identify Broadcast Control Channels. The best unbarred Broadcast Control Channel with the same PLMN as the nanoCell is selected for camping.

A nanoCell nMS subsystem camps on a control channel carrier signal and decodes the System Information messages. Cell reselection will occur only if the control channel is lost or the BTS becomes barred.

The provisioning and authorization process is obtained from the LMT prior to or during installation. The nanoCell is either assigned an ARFCN for its nBTS Broadcast Control Channel (BCCH) carrier by the service provider or it may be allowed to make its own selection from a range of ARFCNs. The nanoCell will cease operation whenever its authorization expires.

Once authorization is obtained, the nanoCell will create an nBTS control channel. The nanoCell copies the design of the control channel on which it is camped and uses it for a timing reference, frame number reference, and a source of broadcast services such as paging and cell broadcast SMS.

The nBTS BCCH messages are copied from the camped on control channel with few changes. The PLMN and LAC are copied with the Cell ID changed to the value provided to the nanoCell during provisioning. The results of the BTS Survey are used to create a neighbor list that will then be broadcast in a System Information message.

Parameters such as Cell Reselect Offset that govern the Mobile Station camping decision may be adjusted to modify the nanoCell's cell size.

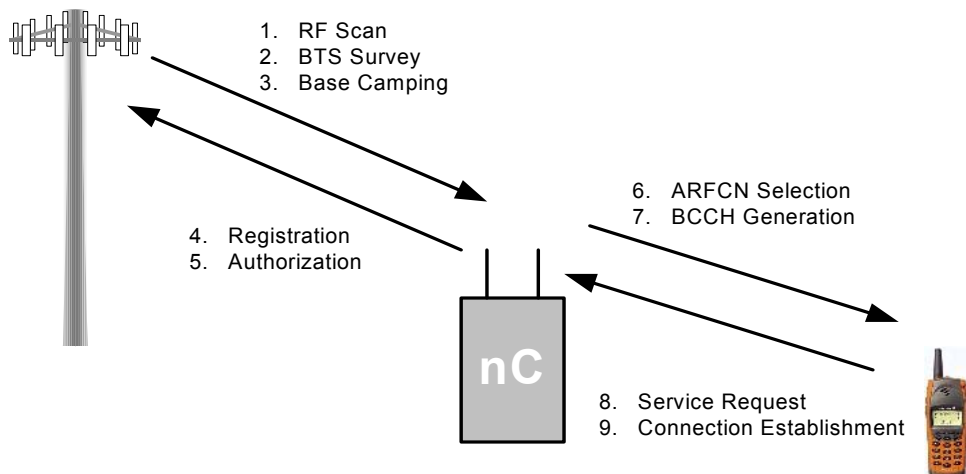

Figure 3. nanoCell Start-up

Link establishment makes maximum use of standard GSM procedures. The nanoCell will copy all paging messages received by the nMS subsystem and will rebroadcast them on the associated PAGCH of the nBTS. All Access Grant messages received from the nMS are intercepted. Any Cell Broadcast SMS messages received by the nMS will be rebroadcast by the nBTS.

A service request from a mobile station (RACH message) to the nanoCell will result in the allocation of a downlink channel and an Immediate Assignment message to the mobile station from the nanoCell. Depending on the type of service request, either an SDCCH or TCH (traffic channel) will be assigned. The mobile station then establishes the link with the nBTS subsystem of the nanoCell using standard GSM processes.

The nanoCell then assumes the identity of the mobile station and sends a service request from its nMS subsystem to the network BTS. A call is then set up between the nMS subsystem on the nanoCell and the BTS.

After the call has been set up, the nanoCell connects the nMS and nBTS subsystems to transparently pass the traffic information between the mobile station and the GSM network. Certain messages, which affect the characteristics of the established channel, such as, channel assignments and mode changes are intercepted by the nanoCell and processed appropriately for the specific channel affected.

2 Tools and Test Equipment

2.1 General

The recommended tools and test equipment consists of equipment required and supplied with the nanoCell and equipment required but not supplied. If a recommended tool or piece of test equipment is not available, an equivalent substitute may be used.

2.2 Equipment Required and Supplied

Table 1-1 contains a list of the equipment that is supplied with the nanoCell.

Table 2-1. Equipment Required and Supplied

Tools/Equipment	Part No.	Manufacturer
Access Door Key		
LMT SW CD		
Anti-Tamper tool		

2.3 Equipment Required but not Supplied

Table 2-2 contains a list of the equipment that is not supplied with the nanoCell.

Table 2-2. Equipment Required but not Supplied

Tools/Equipment	Part No.	Manufacturer
13-mm deep-well socket		
½-drive ratchet		
7-mm hex driver		

2.4 Equipment Recommended but not Supplied

Table 2-3 contains a list of the equipment that is recommended but not supplied with the nanoCell.

Table 2-3. Equipment Recommended but not Supplied

Tools/Equipment	Part No.	Manufacturer
VSWR Meter		
1900 MHz PCS network mobile equipped with field test software		
1900 MHz PCS network mobile		

3 System Installation

The following procedures are to be used when installing the nanoCell and its associated antennas.

3.1 Antenna Assembly

There are two antennas to be installed, one for the mobile side of the nanoCell and one for the BTS side. The minimum separation between the antennas is site dependant; refer to the site configuration sheet. The main concern in antenna separation is to obtain 60 dB or more of attenuation between the nMS and nBTS antennas.

3.1.1 Antenna

The antennas are standard GSM antennas and are to be mounted in accordance with company procedures.

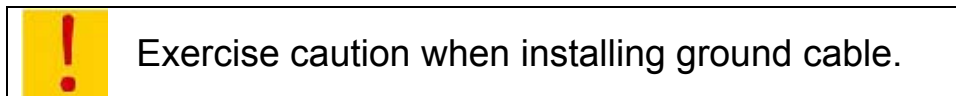

3.1.2 Cabling

Cables are to be terminated and dressed in accordance with current company installation procedures.

3.1.3 Grounding

Grounding of the antennas is to be in accordance with company and local building codes. A minimum of 6-gauge wire is to be utilized.

3.2 nanoCell Assembly

The following procedures are to be followed when installing the nanoCell. The nanoCell is capable of being mounted in one of three configurations: pole mount, wall mount, or pad mount. This manual will address the pole mounting of the nanoCell.

3.2.1 Unpacking the nanoCell

This may be done in the warehouse prior to shipment to the installation site. The following steps need to be followed when initially unpacking the nanoCell.

- a. Verify that there is no visible damage to the shipping container. Make note of any damage prior to opening the container. Notify the shipper if there is visible damage to the exterior of the container.
- b. Verify all components listed on the parts list are present. Record any discrepancies.
- c. Inspect the nanoCell for any signs of damage that may have occurred during transit.
- d. If there is any damage to the nanoCell contact the shipper and then notify Telephonics at (321)-757-6336.

3.2.2 Mounting the nanoCell

The following procedure is used to mount the nanoCell to poles located near the antenna pad. Verify that the poles have been placed and are of sufficient diameter to support the nanoCell. Refer to Figure 4 for a general view of the pole-mounted nanoCell and to Figure 5 for the detailed mounting instructions.

Tools needed for installation

- a. 13-mm socket
- b. ½-inch drive ratchet
- c. 7-mm hex driver

Installation instructions

- a. Adjust the size of the profile bar C (1) to the size of the nanoCell chassis.
- b. Using a 7 mm screwdriver, attach the four profile bars (1) to the back of the nanoCell chassis using the washer (2) and the cylinder screw (3).
- c. Screw the headless pin (4) into the lock nut (5) and slide into the profile bar.
- d. Place the clamp profile (6) over the headless pin (4) and tighten nut (7) until assembly is finger tight.
- e. Repeat step “d” for the other clamp profile assemblies.
- f. Once the clamp profile assemblies have been loosely installed, move the nanoCell to the mounting poles.
- g. Place the nanoCell next to the poles to obtain the proper spacing of the clamp profile assemblies.
- h. Once the proper spacing has been determined for the clamp profile assemblies, tighten them down (7) using the 13-mm socket.
- i. Place the tightening strap (8) around the pole (12) and place the tightening angles (6) on either side of the tightening strap.
- j. Place the tightening strap (8) and tightening angles (6) over the headless pins (4).
- k. Place the washer (10) and the nut (11) onto the headless pin and tighten finger tight.
- l. Repeat step “k” for all remaining tightening straps and tightening angles.



Exercise care when lifting nanoCell into position.

- m. When all tightening straps and tightening angles are installed, lift the nanoCell to the desired height. It is recommended that three men perform this task. Two to lift and one to tighten.
- n. When at the proper height, use the 13-mm socket to tighten the tightening straps and tightening angles.

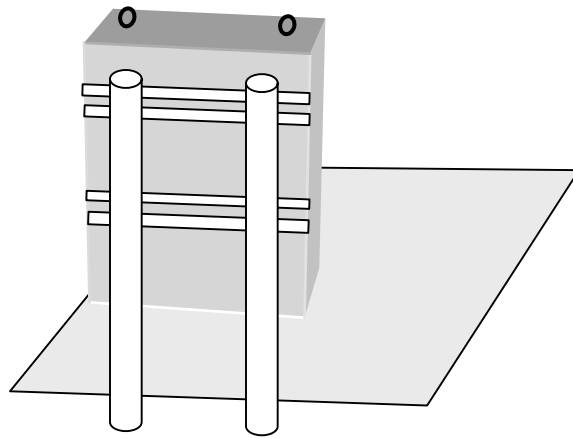

Figure 4. Pole Mount of the nanoCell

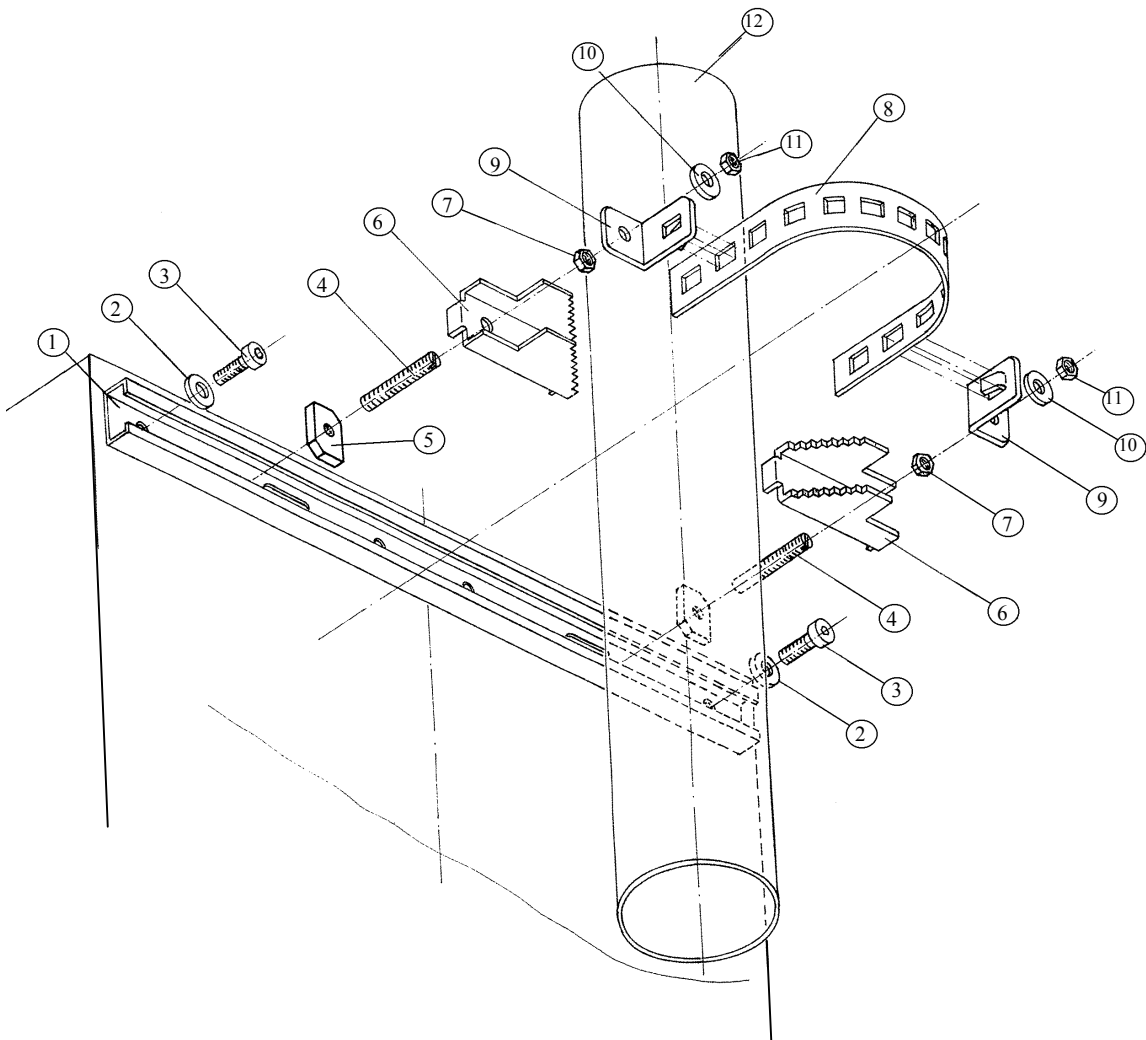

Figure 5. Detailed nanoCell Mounting Diagram

3.2.3 nanoCell Grounding

Grounding of the nanoCell is to be in accordance with local building codes. A minimum of 6-gauge wire is to be utilized. Figure 6 shows the location of the antenna ground tie-in. The ground bar is fed in from the bottom access of the nanoCell. The four nuts are loosened and the bar slid under the nuts. The nuts are tightened to secure the ground bar to the nanoCell chassis.

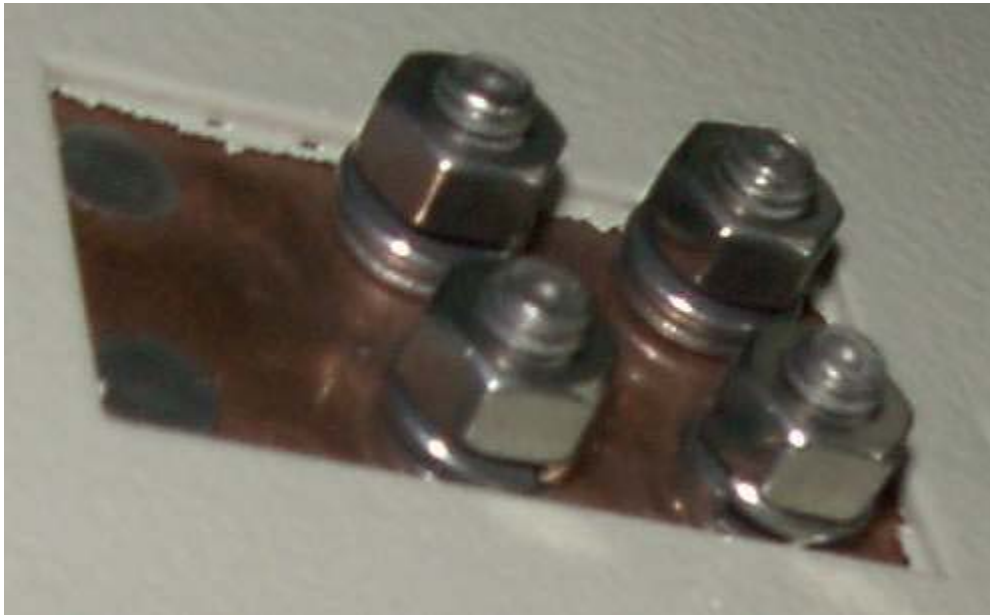
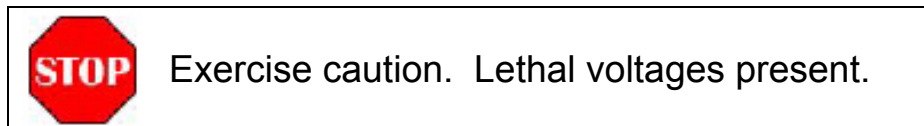

Figure 6. nanoCell Grounding Tie-in Point

3.2.4 Power Application

The nanoCell is capable of being powered by AC or DC power. This manual will address the application of AC power. Follow the procedures listed below to install power to the nanoCell.

- a. Locate the source for the 115 VAC, 230 VAC, 20 AMP service.



- b. Ensure the main breaker for the power is in the **OFF** position.
- c. Connect the power cables as shown in Figure 7.
- d. Access is gained through the bottom of the nanoCell.

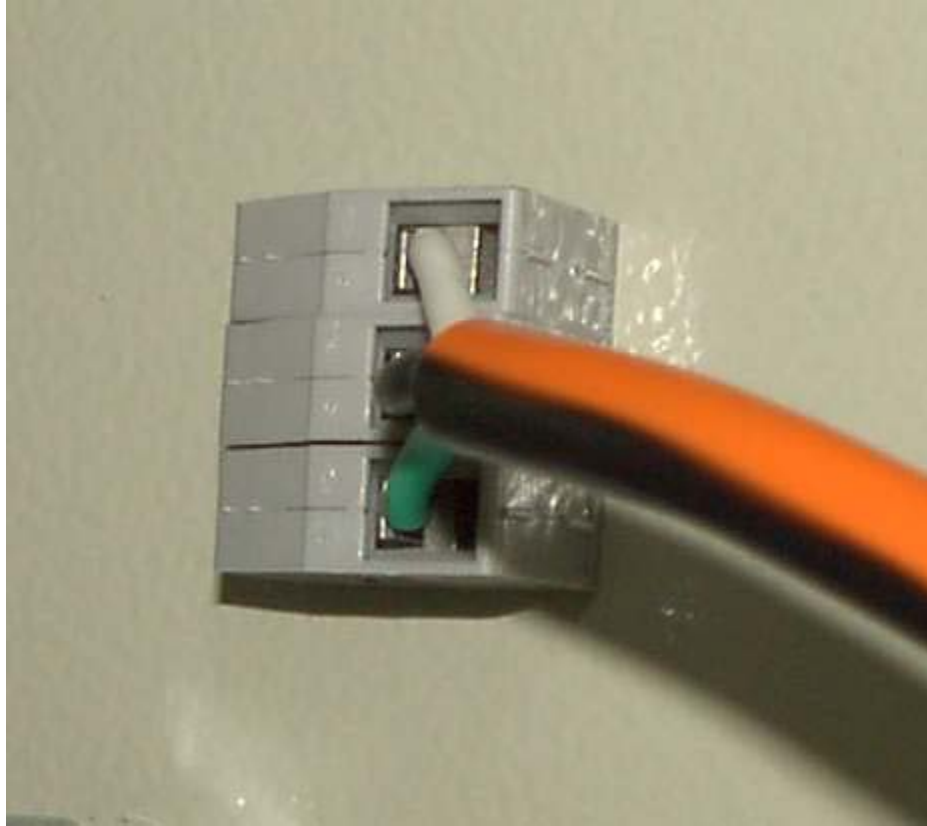

Figure 7. Power Connections

3.2.5 Cabling

The final step in installing the nanoCell is to connect the antennas. Using Figure 8 as a reference, connect the cable from the nMS antenna to the N-type connector on the left. Connect the nBTS antenna to the connector on the right. Access to the antenna connectors is from the bottom of the nanoCell.



Figure 8. Antenna Connections

4 System Commissioning

The following steps are to be followed when commissioning the nanoCell.

4.1 Power-up

Power to the nanoCell is controlled from the circuit breaker panel. When you are ready to apply power to the nanoCell, place the main circuit breaker to the ON position.



Approximately five minutes to complete the boot process.

4.2 System Start-up

On application of primary power, the nanoCell will automatically start up in a controlled manner. All nBTS subsystem RF hardware is inhibited automatically on startup to prevent unauthorized transmissions and is held in an idle state until the unit has been tested and is properly authorized to operate.

The nanoCell will execute a Boot program from internal ROM on application of power or after any reset event. Reset events can occur from manual command input, a watchdog timer expiration, or an anti-tamper event occurrence.

The Boot program will initialize the hardware, perform a compatibility check with the hardware, execute POST (Power On Self Test), and activate the internal Ethernet port with a command line interface. The Boot program will report the results of the POST on the command line interface and on internal LEDs. Any failure of the POST will force the nanoCell to remain in the Boot program until reset.

It should be emphasized that the command line interface and internal LED display is made available for maintenance and depot operations only and no external input is required for normal startup and operation of the nanoCell. Typically there is no connection to the command line interface port after the unit is installed unless maintenance is required. There are no external

visual indicators on the unit. Only non-field service would require the unit to be opened for observation of the LEDs.

After POST successfully completes, the nanoCell's application program will examine the system configuration database and complete its hardware and software compatibility checks. If there is a detected incompatibility or the minimum required data is not present, the nanoCell will wait in a non-operational mode for data input via the command line interface or remote program load using BOOTP protocol. Lack of data would indicate that the nanoCell has not been. The nanoCell will not progress any further until properly programmed and reset.

A connection to the LMT permits the download of additional control parameters and/or application software as necessary, as well as uploading nanoCell status and event data. The nanoCell can be commanded to enter the Maintenance mode at any time by the LMT. Application software may be downloaded via the command line interface while the nanoCell is in this mode. When valid application software is present, the nanoCell will proceed to execute the application.

4.3 System Provisioning

The nanoCell is provisioned using the Local Maintenance Terminal software. The information necessary for input will be contained in the site reference document.

There are two areas that will be addressed during the provisioning process; System Parameters and Licensing.

Tools needed for provisioning

- a. Laptop with LMT software
- b. CAT-5 Ethernet cable

Installation instructions

- a. Power on the laptop and connect the Ethernet cable to the Ethernet port located inside the right access panel. (As viewed from the front of the nanoCell).
- b. Verify that power has been applied to the nanoCell for at least 5 minutes to allow time for the nanoCell boot process to complete.
- c. Once the laptop has booted and power applied to the nanoCell, double-click the LMT icon located on the desktop of the laptop.
- d. The LMT software will launch and will display the screen as shown in Figure 9.

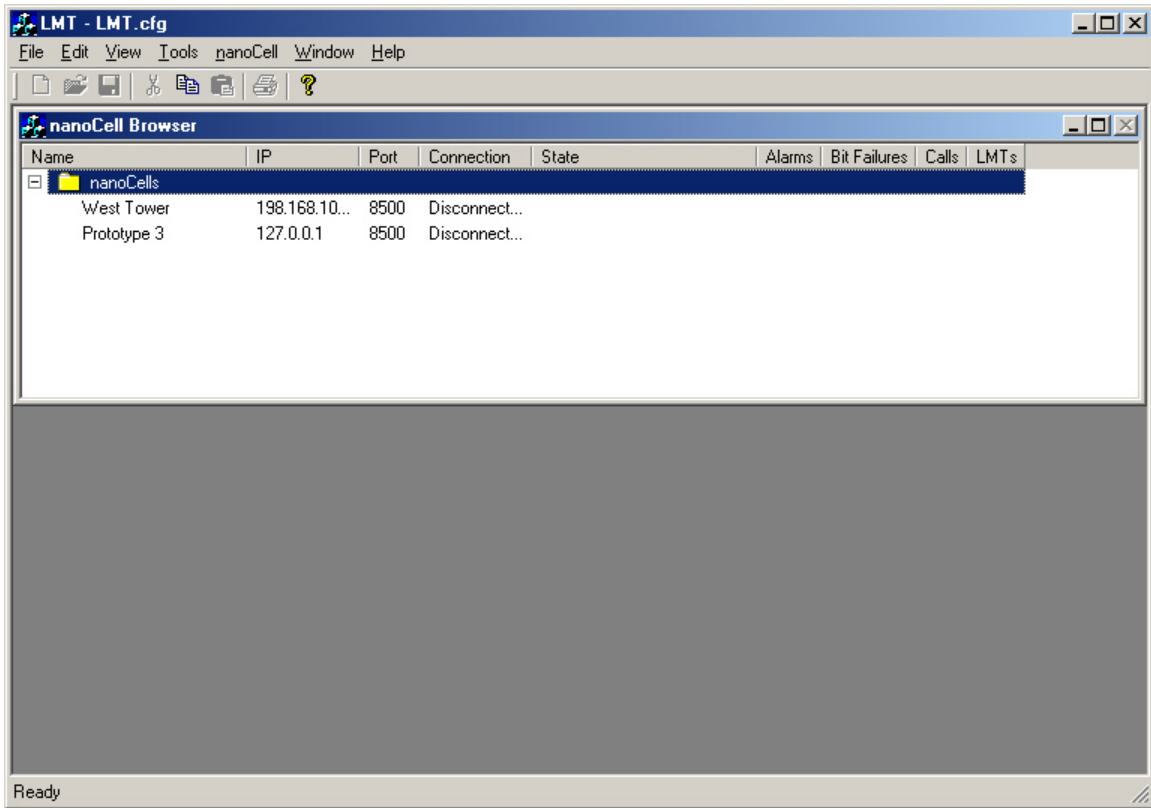

Figure 9. LMT Opening Screen

- e. In the browser area of the screen, right click on a nanoCell.
- f. From the drop-down menu, select ADD. This brings of the dialog box as shown in Figure 10.

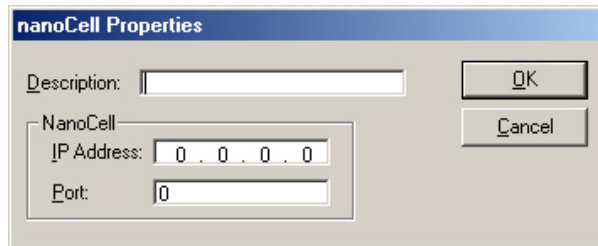

Figure 10. Properties Dialog Box

- g. Type in the description of the nanoCell site. (i.e. Texahoma Water Tower)
- h. Type in the IP address.
- i. The port defaults to 8500.
- j. Close the dialog box. This will add a new nanoCell to the list.
- k. Highlight the desired nanoCell and right-click.

- l. Select “Connect” from the drop-down menu.
- m. Right-click on the selected nanoCell and select “Parameters” from the drop-down menu. This will bring of the dialog box as shown in Figure 11.

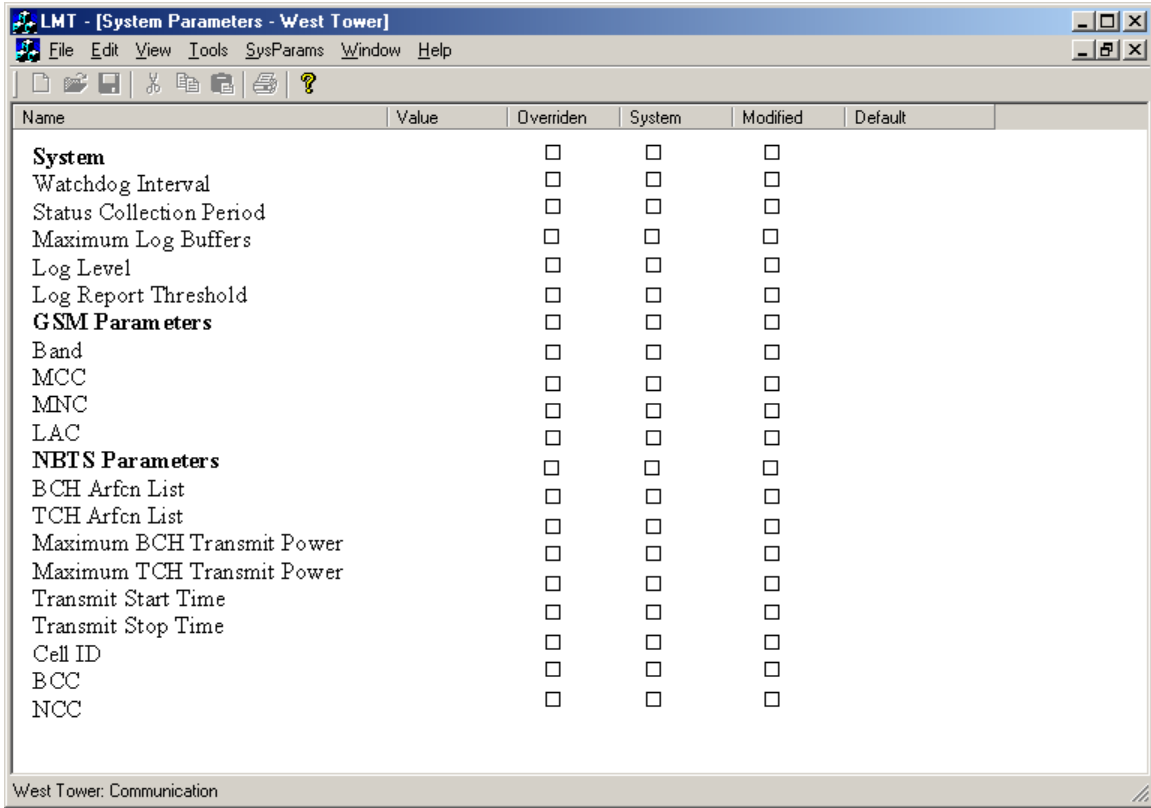

Figure 11. System Parameters Dialog Box

- n. Select the required fields and enter the proper information as obtained from the site configuration sheet. Continue on to step “o” when finished.
- o. On the LMT Menu bar, select Sys Params and from the drop-down menu click “Send to nanoCell”. This will post the results to the nanoCell.
- p. The system will then provide the prompt: “Update nanoCell?” Select YES.
- q. The dialog box will refresh. Verify the information you just entered is correct.

5 Installation Test and Final Acceptance

Once the nanoCell has been installed and provisioned, it is necessary to verify nanoCell operation. The following steps and procedure allow the technician to activate and test the nanoCell.

5.1 Power-up

Apply power to the nanoCell by placing the main circuit breaker to the on position. Wait at least 5 minutes to allow the nanoCell time to complete its boot process.

5.2 Start-up

Start-up of the nanoCell is automatic. Once power is applied the nanoCell will go through its boot process (approximately 5 minutes) and will wait for authorization to transmit.

5.3 System Configuration

Using LMT, verify all of the system parameters from the site configuration sheet.

- a. Power on the laptop and connect the Ethernet cable to the Ethernet port located inside the right access panel. (As viewed from the front of the nanoCell).
- b. Verify that power has been applied to the nanoCell.
- c. Once the laptop has booted and power applied to the nanoCell, double-click the LMT icon located on the desktop of the laptop.
- d. The LMT software will launch and will display the screen as shown in Figure 12.

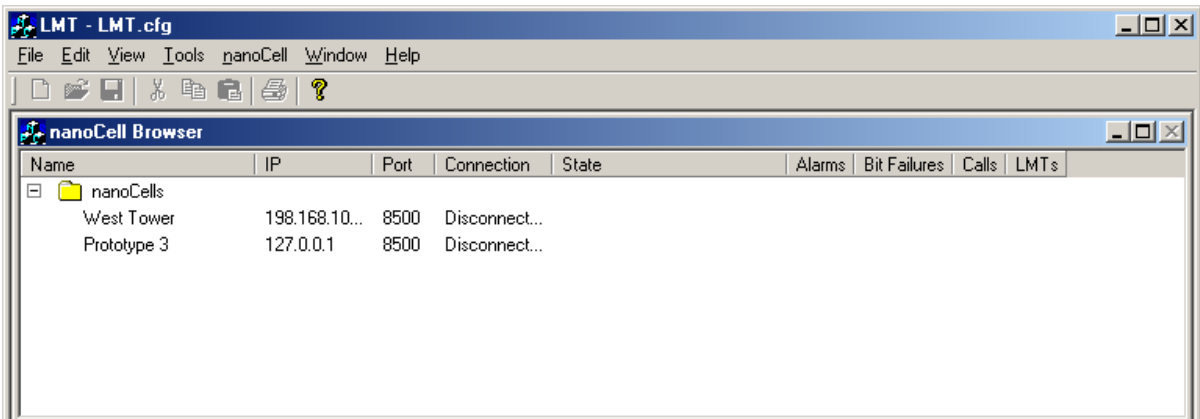

Figure 12. LMT Opening Screen

- e. Highlight the desired nanoCell and right-click.
- f. Select "Connect" from the drop-down menu.
- g. Right-click on the selected nanoCell and select "Parameters" from the drop-down menu. This will bring of the dialog box as shown in Figure 13.

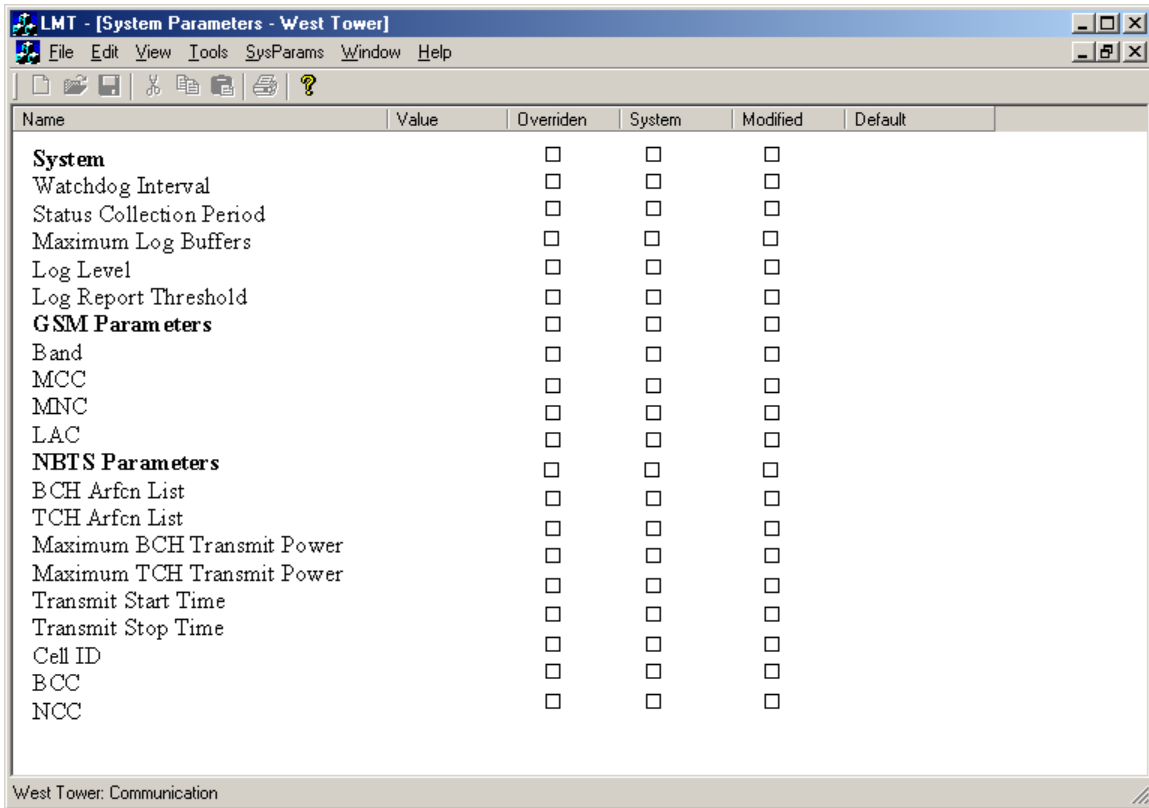

Figure 13. System Parameters Dialog Box

- h. Verify the information is correct.
- i. Verify the license information is correct.

5.4 Field Acceptance Test

The following tests are conducted to ensure the functionality of the nanoCell. Table 5-1 is used to identify the tests needed and serves as a checklist for documenting their completion.

Table 5-1. Field Acceptance Tests

Item	Test	Description	Pass/Fail
1	Configuration using LMT		
2	Establish Configuration	1 nBTS radio, 4 nMS radios in service	
3	Provisioning		
4	License activation		
5	Basic GSM Call Functionality		
6	Perform 10 successful camps	Done after power cycles.	
7	Location Update		
8	MS to MS Calls		

Item	Test	Description	Pass/Fail
9	Perform 7 successful calls.		
10	Perform calls on each model of MS available.		
11	Perform Emergency Calls.		
12	GSM Security Functionality		
13	Perform Authentication Testing.		
14	Perform Ciphering Testing.		
15	Handovers		
16	Adjustment of RX_Min_lev.	Establish BTS/nanoCell border	
17	Fast Handover With 1 measurement report.	Set SysParams "HO MinRxLev", "95"	
18	Slow Handover With 999 measurement reports.	Set SysParams "HO MinRxLev", "95"	
19	Driving from nanoCell to BTS with active call.	Adjusted HO MinRxLev established.	
20	Handing into camping BTS.		
21	Handing into nanoCell from camping BTS.		

6 Return Materials Authorization

In the event that a depot repair or hardware replacement is required after contacting Customer Service, please contact Telephonics for return authorization. The following information is required by Telephonics:

- full description of the product(s): model and part number
- serial number of the product(s)
- purchase order number
- quantity that needs to be returned to Telephonics, if applicable
- description of observed problem

All Telephonics products carry a manufacturing warranty from the date of shipment. At the time of a request for a return authorization, if the product has exceeded the warranty period, Telephonics will require a new purchase order number to cover the cost of non-warranty repair. Contact Sales Operations at Telephonics headquarters in Melbourne, FL, USA at +1-(321)- 757-6336.

Appendix A - Installation Checklist

The following checklist should be used to check the installation of the nanoCell has proceeded successfully.

Description	Value
Site Name	
IP Address	
IP Name (optional)	
BSC Name	
MSC Name	
Site/Access Phone Number	

Unpacking the nanoCell

- 1 __ No visible damage to shipping materials
- 2 __ All parts included per shipping invoice

Outside Pad Mounting (if applicable)

- 1 __ nanoCell installed
- 2 __ Chassis enclosure grounded
- 3 __ Power cables run
- 4 __ Antenna cables connected
- 5 __ Enclosure door locked
- 6 __ Power applied: 115 VAC

Antenna Cables

Visual inspections performed on antenna cables.

- 1 __ RF Cables must not be kinked, cut or damaged in any way.
- 2 __ Connect the RF cables to the antennas taking care to avoid cross-threading or stripping. The RF connectors should be snug and tight.
- 3 __ Seal the antenna and repeater connectors with waterproof sealant or the appropriate weather tight boot.

Provisioning the nanoCell

- 1 __ Configure the nanoCell with parameters found in the site configuration sheet.
- 2 __ Ensure power to nanoCell is on
- 3 __ Ensure the nanoCell has the proper license file

