



FCC 47 CFR PART 22 SUBPART H AND PART 24 SUBPART E

TEST REPORT

For

GSM/GPRS module

Model: A8000

Trade Name: Longsung

Issued to

**Longcheer Technology (Shanghai) Co., Ltd
Building1,NO401,Caobao Rd, Xuhui District,
Shanghai, P.R.China**

Issued by

COMPLIANCE CERTIFICATION SERVICES (KUNSHAN) INC.

**10#Weiye Rd, Innovation Park Eco. & Tec. Development Zone
Kunshan city JiangSu, (215300) CHINA**

TEL: 86-512-57355888

FAX: 86-512-57370818



Note: This report shall not be reproduced except in full, without the written approval of Compliance Certification Services Inc. This document may be altered or revised by Compliance Certification Services Inc. personnel only, and shall be noted in the revision section of the document.



TABLE OF CONTENTS

1. TEST RESULT CERTIFICATION.....	3
2. EUT DESCRIPTION	4
3. TEST METHODOLOGY	5
3.1 EUT CONFIGURATION	5
3.2 EUT EXERCISE	5
3.3 GENERAL TEST PROCEDURES	5
3.4 DESCRIPTION OF TEST MODES	5
4. INSTRUMENT CALIBRATION.....	6
5. FACILITIES AND ACCREDITATIONS	7
5.1 FACILITIES	7
5.2 EQUIPMENT	7
5.3 LABORATORY ACCREDITATIONS AND LISTING	7
5.4 TABLE OF ACCREDITATIONS AND LISTINGS	8
6. SETUP OF EQUIPMENT UNDER TEST	9
6.1 SETUP CONFIGURATION OF EUT	9
6.2 SUPPORT EQUIPMENT	9
7. FCC PART 22 & 24 REQUIREMENTS	10
7.1 PEAK POWER	10
7.2 ERP & EIRP MEASUREMENT	12
7.3 OCCUPIED BANDWIDTH MEASUREMENT	15
7.4 OUT OF BAND EMISSION AT ANTENNA TERMINALS	23
7.5 FIELD STRENGTH OF SPURIOUS RADIATION MEASUREMENT	42
7.6 FREQUENCY STABILITY V.S. TEMPERATURE MEASUREMENT	49
7.7 FREQUENCY STABILITY V.S. VOLTAGE MEASUREMENT	51
7.8 POWERLINE CONDUCTED EMISSIONS	53



1. TEST RESULT CERTIFICATION

Applicant: Longcheer Technology (Shanghai) Co., Ltd
 Building 1, NO401, Caobao Rd, Xuhui District, Shanghai, P.R.China

Equipment Under Test: GSM/GPRS module

Trade Name: Longsung

Model Number: A8000

Date of Test: July 1, 2009~July 3, 2009

APPLICABLE STANDARDS	
STANDARD	TEST RESULT
FCC 47 CFR PART 22 SUBPART H AND PART 24 SUBPART E	No non-compliance noted

We hereby certify that:

The above equipment was tested by Compliance Certification Services Inc. The test data, data evaluation, test procedures, and equipment configurations shown in this report were made in accordance with the procedures given in ANSI/TIA/EIA-603-A-2001 and the energy emitted by the sample EUT tested as described in this report is in compliance with conducted and radiated emission limits of FCC Rule FCC PART 22 Subpart H and PART 24 Subpart E.

The test results of this report relate only to the tested sample identified in this report.

Approved by:

Miro Chueh
 Section Manager of Kunshan Laboratory
 Compliance Certification Services Inc.

Reviewed by:

Lin Zhang
 EMC Supervisor of Kunshan Laboratory
 Compliance Certification Services Inc.



2. EUT DESCRIPTION

Product	GSM/GPRS module
Trade Name	Longsung
Model Number	A8000
Model Discrepancy	N/A
Power Supply	AC to DC charger Trade Name :Longcheer Model Number :ASSA1-080200 Input: AC100-240V, 50/60Hz, 0.68A Output:DC8.0V,2000mA Module: Input: DC 3.5V to 4.2V
Frequency Range	TX: 824 ~ 849 MHz / 1850 ~ 1909.8 MHz RX: 869 ~ 894 MHz / 1930 ~ 1990 MHz
Transmit Power(conducted)	GSM 850: 31.12dBm PCS 1900: 27.31dBm
Cellular Phone Protocol	GSM 850MHz; PCS 1900MHz GPRS Class12 850MHz;GPRS Class 12 1900MHz
Type of Emission	245.71 KGXW
Antenna Type	Monopole Antenna ; Gain:0dBi(Max)

Remark: This submittal(s) (test report) is intended to comply with Part 22 and Part 24 of the FCC 47 CFR Rules.



3. TEST METHODOLOGY

Both conducted and radiated testing were performed according to the procedures document on chapter 13 of ANSI C63.4 2003 and FCC CFR 47, 2.1046, 2.1047, 2.1049, 2.1051, 2.1053, 2.1055 and 2.1057.

EUT CONFIGURATION

The EUT configuration for testing is installed on RF field strength measurement to meet the Commissions requirement and operating in a manner that intends to maximize its emission characteristics in a continuous normal application.

EUT EXERCISE

The EUT was operated in the engineering mode to fix the TX frequency that was for the purpose of the measurements.

GENERAL TEST PROCEDURES

Conducted Emissions

The EUT is placed on the turntable, which is 0.8 m above ground plane. According to the requirements in Section 13.1.4.1 of ANSI C63.4 2003. Conducted emissions from the EUT measured in the frequency range between 0.15 MHz and 30MHz using CISPR Quasi-peak and average detector modes.

Radiated Emissions

The EUT is placed on a turn table, which is 0.8 m above ground plane. The turntable shall rotate 360 degrees to determine the position of maximum emission level. EUT is set 3m away from the receiving antenna, which varied from 1m to 4m to find out the highest emission. And also, each emission was to be maximized by changing the polarization of receiving antenna both horizontal and vertical. In order to find out the maximum emissions, exploratory radiated emission measurements were made according to the requirements in Section 13.1.4.1 of ANSI C63.4 2003

DESCRIPTION OF TEST MODES

The EUT (Model:A8000)had been tested under operating condition.
EUT staying in link mode was programmed.

After verification, all tests were carried out with the worst case test modes as shown below except radiated spurious emission below 1GHz and power line conduction emission below 30MHz, which worst case was in normal link mode only.

GSM/GPRS 850:

Channel Low/Mid/High and H plan were chosen for full testing.

GSM/GPRS 1900:

Channel Low/Mid/High and H plan were chosen for full testing.



4. INSTRUMENT CALIBRATION

The measuring equipment, which was utilized in performing the tests documented herein, has been calibrated in accordance with the manufacturer's recommendations for utilizing calibration equipment, which is traceable to recognized national standards.



5. FACILITIES AND ACCREDITATIONS

FACILITIES

All measurement facilities used to collect the measurement data are located at CCS China Kunshan Lab at 10#, Weiye Rd, Innovation Park Eco. & Tec. Development Zone Kunshan city JiangSu, (215300)CHINA.

The sites are constructed in conformance with the requirements of ANSI C63.4 2003 and CISPR Publication 22.

EQUIPMENT

Radiated emissions are measured with one or more of the following types of linearly polarized antennas: tuned dipole, biconical, log periodic, bi-log, and/or ridged waveguide, horn. Spectrum analyzers with pre-selectors and quasi-peak detectors are used to perform radiated measurements.

Conducted emissions are measured with Line Impedance Stabilization Networks and EMI Test Receivers.



Calibrated wideband preamplifiers, coaxial cables, and coaxial attenuators are also used for making measurements.

All receiving equipment conforms to CISPR Publication 16-1, "Radio Interference Measuring Apparatus and Measurement Methods."

LABORATORY ACCREDITATIONS AND LISTING

The test facilities used to perform radiated and conducted emissions tests are accredited by American Association for Laboratory Accreditation Program for the specific scope accreditation under 2541.01 to perform Electromagnetic Interference tests according to FCC Part 22&24 and CISPR 22 requirements. In addition, the test facilities are listed with Industry Canada, Certification and Engineering Bureau, IC 2324E-1 for 3/10m Chamber.

TABLE OF ACCREDITATIONS AND LISTINGS

Country	Agency	Scope of Accreditation	Logo
USA	A2LA	47 CFR FCC Part 15/18 (using ANSI C63.4 2003); VCCI V3; CNS 13438; CNS 13439; CNS 13803; CISPR 11; EN 55011; CISPR 13; EN 55013; CISPR 22:2005; CISPR 22:1997 +A1 :2000+A2 :2002; EN 55022:2006; EN55022 :1998 +A1 :2001+A2 :2003; EN 61000-6-3 (excluding discontinuous interference); EN 61000-6-4; AS/NZS CISPR 22; CAN/CSA-CEI/IEC CISPR 22; EN 61000-3-2; EN 61000-3-3; EN550024; EN 61000-4-2; EN 61000-4-3; EN61000-4-4; EN 61000-4-5; EN 61000-4-6; IEC 61000-4-8; EN 61000-4-11; IEC61000-3-2; IEC61000-3-3; IEC 61000-4-2; IEC 61000-4-3; IEC 61000-4-4; IEC 61000-4-5; IEC 61000-4-6; IEC 61000-4-8; IEC 61000-4-11; EN 300 220-3; EN 300 328; EN 300 330-2; EN 300 440-1; EN 300-440-2; EN 300 893; EN 301 489-01; EN 301 489-3; EN 301 489-07; EN 301 489-17, 301 489-19, 301 489-24, 301 489-25, 301 511 clause 4.2.2 and clause 4.2.3 and clause 5.3.1 and clause 5.3.2; EN 301 908-2 clause 4.2.4 and clause 4.2.10 and clause 5.3.9; 47 CFR FCC Part 15, 22, 24	
USA	FCC	3/10 meter Sites to perform FCC Part 15/18 measurements	 238958, 424105
Japan	VCCI	3/10 meter Sites and conducted test sites to perform radiated/conducted measurements	VCCI R-1600 C-1707 T-1499

* No part of this report may be used to claim or imply product endorsement by A2LA or any agency of the US Government.



6. SETUP OF EQUIPMENT UNDER TEST

SETUP CONFIGURATION OF EUT

See test photographs attached in Appendix 1 for the actual connections between EUT and support equipment.

SUPPORT EQUIPMENT

No.	Device Type	Brand	Model	FCC ID	Series No.	Data Cable	Power Cord
1	N/A						

Remark:

1. All the equipment/cables were placed in the worst-case configuration to maximize the emission during the test.
2. Grounding was established in accordance with the manufacturer's requirements and conditions for the intended use.



7. FCC PART 22 & 24 REQUIREMENTS

AVERAGE POWER

LIMIT

According to FCC §2.1046.

MEASUREMENT EQUIPMENT USED

Name of Equipment	Manufacturer	Model	Serial Number	Calibration Due
Peak and Avg Power Sensor	Agilent	E9327A	US40441788	07/30/2009
EPM-P Series Power Meter	Agilent	E4416A	QB41292714	07/30/2009
Spectrum Analyzer	Agilent	E4446A	MY44020154	08/16/2009
Wireless communication test set	Agilent	8960	QB44051695	10/06/2009

Remark: Each piece of equipment is scheduled for calibration once a year.

Test Configuration

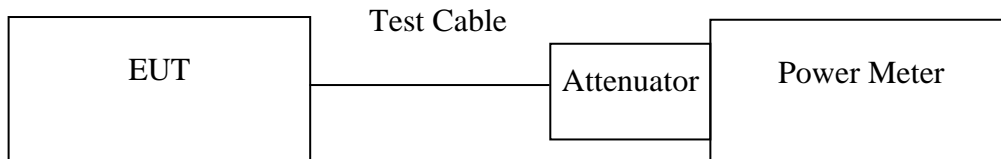

Remark: Measurement setup for testing on Antenna connector

TEST PROCEDURE

The transmitter output was connected to a calibrated attenuator, the other end of which was connected to a power meter. Transmitter output was read off the power meter in dBm. The power output at the transmitter antenna port was determined by adding the value of the attenuator to the power meter reading.

**TEST RESULTS***No non-compliance noted.***Test Data**

Test Mode	CH	Frequency (MHz)	Power Meter Reading (dBm)	Factor (dB)	Average Power (dBm)
GSM 850	128	824.20	6.07	26.50	31.12
	190	836.60	5.46		30.51
	251	848.80	5.04		30.09

Test Mode	CH	Frequency (MHz)	Power Meter Reading (dBm)	Factor (dB)	Average Power (dBm)
GSM 1900	512	1850.20	3.72	24.50	27.31
	661	1880.00	3.20		26.79
	810	1909.80	3.71		27.28

Test Mode	CH	Frequency (MHz)	Power Meter Reading (dBm)	Factor (dB)	Average Power (dBm)
GPRS 850	128	824.20	6.07	26.50	30.99
	190	836.60	5.46		30.11
	251	848.80	5.04		29.66

Test Mode	CH	Frequency (MHz)	Power Meter Reading (dBm)	Factor (dB)	Average Power (dBm)
GPRS 1900	512	1850.20	3.72	24.50	27.13
	661	1880.00	3.20		26.55
	810	1909.80	3.71		26.98

Remark: The value of factor includes both the loss of cable and external attenuator

ERP & EIRP MEASUREMENT

LIMIT

According to FCC §2.1046

FCC 22.913(b): The Effective Radiated Power (ERP) of mobile transmitters must not exceed 7 Watts.

FCC 24.232(b): The equivalent Isotropic Radiated Power (EIRP) must not exceed 2 Watts.

MEASUREMENT EQUIPMENT USED

977 Chamber (3m)				
Name of Equipment	Manufacturer	Model	Serial Number	Calibration Due
Spectrum Analyzer	Agilent	E4446A	MY44020154	08/16/2009
EMI Test Receiver	R&S	ESPI3	101026	11/11/2009
Pre-Amplifier	MINI-circuits	ZFL-1000VH2	d041703	12/13/2009
Pre-Amplifier	Miteq	NSP4000-NF	870731	01/28/2010
Bilog Antenna	Sunol	JB1	A110204-2	11/22/2009
Horn-antenna	SCHWARZBECK	BBHA9120D	D:266	02/01/2010
PSG Analog Signal Generator	Agilent	E8257C	MY43321570	12/19/2009
Wireless communication test set	Agilent	8960	QB44051695	10/06/2009
Turn Table	CT	CT123	4165	N.C.R
Antenna Tower	CT	CTERG23	3256	N.C.R
Controller	CT	CT100	95637	N.C.R
Site NSA	CCS	N/A	N/A	04/06/2010

Remark: Each piece of equipment is scheduled for calibration once a year.

TEST CONFIGURATION

Below 1 GHz

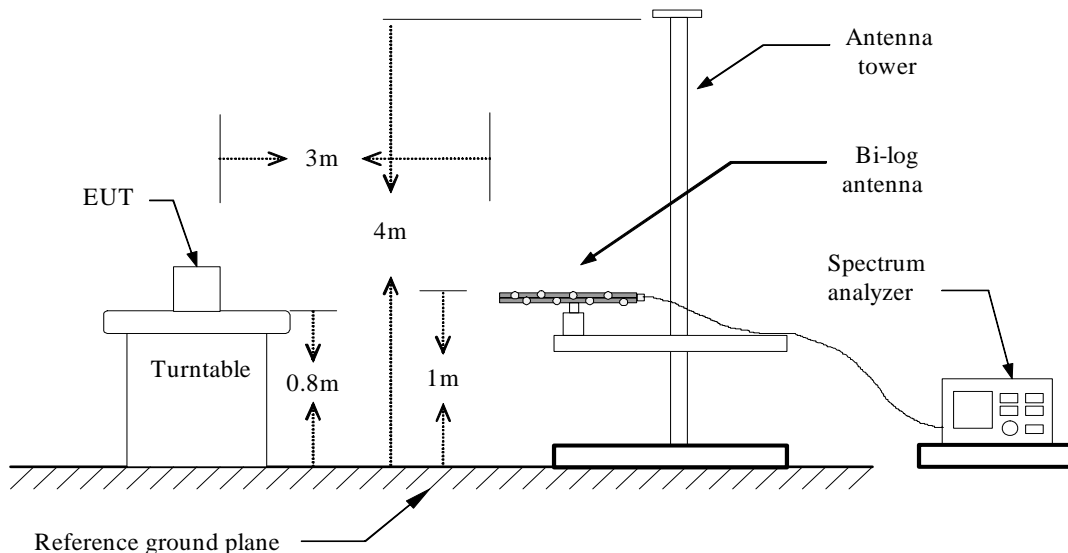

Above 1 GHz

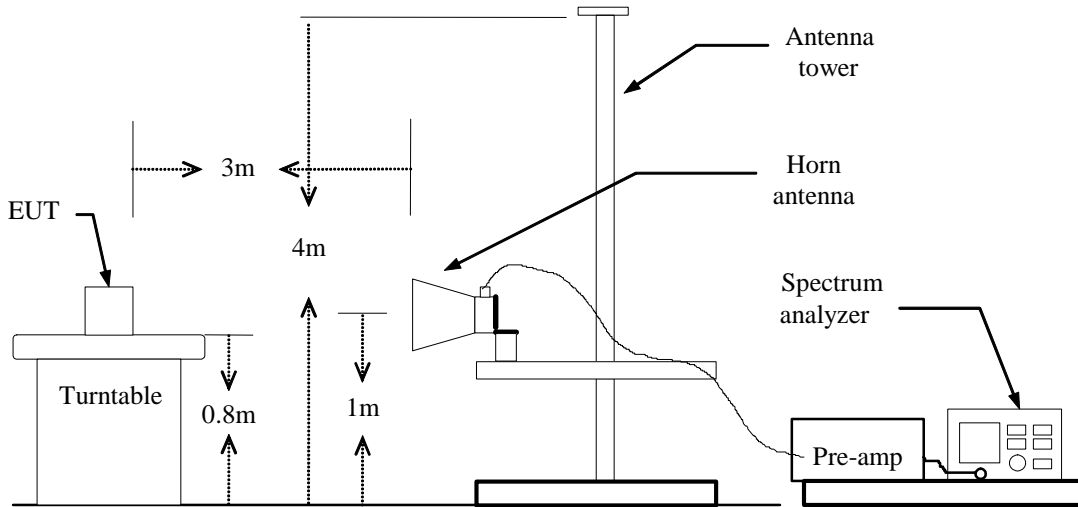

For Substituted Method Test Set-UP

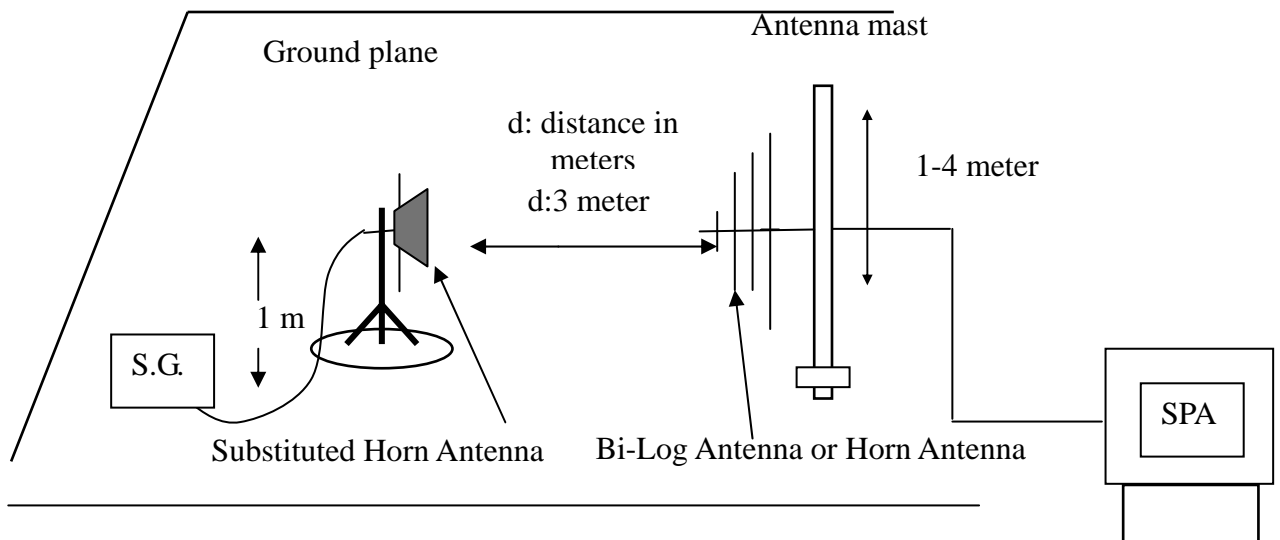

TEST PROCEDURE

The EUT was placed on an non-conductive turntable using a non-conductive support. The radiated emission at the fundamental frequency was measured at 3 m with a test antenna and EMI spectrum analyzer.

During the measurement of the EUT, the resolution bandwidth was set to 3MHz and the average bandwidth was set to 3MHz. The highest emission was recorded with the rotation of the turntable and the lowering of the test antenna. The reading was recorded and the field strength (E in dBm) was calculated. The spectrum analyzer reading was recorded and ERP/EIRP was calculated as follows:

$$ERP = \text{S.G. output (dBm)} + \text{Antenna Gain (dBd)} - \text{Cable (dB)}$$

$$EIRP = \text{S.G. output (dBm)} + \text{Antenna Gain (dBi)} - \text{Cable (dB)}$$

**TEST RESULTS***No non-compliance noted.***GSM 850**

EUT Pol.	Channel	Frequency (MHz)	Reading level (dBm)	Antenna Pol.	S.G. (dBm)	Cable loss (dB)	Ant.Gain (dBd)	Emission level (dBm)	Limit (dBm)	Margin (dB)
H	128	824.20	-5.98	V	26.00	2.87	6.2	29.33	38.5	-9.17
		824.20	-7.04	H	24.94	2.87	6.2	28.27	38.5	-10.23
	190	836.60	-6.87	V	24.92	2.88	6.4	28.44	38.5	-10.06
		836.60	-7.75	H	24.04	2.88	6.4	27.56	38.5	-10.94
	251	848.80	-7.86	V	23.89	2.94	6.5	27.45	38.5	-11.05
		848.80	-7.19	H	24.56	2.94	6.5	28.12	38.5	-10.38

GSM 1900

EUT Pol.	Channel	Frequency (MHz)	Reading level (dBuV)	Antenna Pol.	S.G. (dBm)	Cable loss (dB)	Ant.Gain (dBi)	Emission level (dBm)	Limit (dBm)	Margin (dB)
H	512	1850.20	-19.26	V	22.18	4.31	8.45	26.32	33	-6.68
		1850.20	-20.24	H	21.20	4.31	8.45	25.34	33	-7.66
	661	1880.00	-20.46	V	21.17	4.53	8.48	25.12	33	-7.88
		1880.00	-21.21	H	20.42	4.53	8.48	24.37	33	-8.63
	810	1909.80	-19.70	V	21.91	4.55	8.52	25.88	33	-7.12
		1909.80	-20.36	H	21.25	4.55	8.52	25.22	33	-7.78

GPRS 850

EUT Pol.	Channel	Frequency (MHz)	Reading level (dBuV)	Antenna Pol.	S.G. (dBm)	Cable loss (dB)	Ant.Gain (dBd)	Emission level (dBm)	Limit (dBm)	Margin (dB)
H	128	824.20	-6.66	V	25.32	2.87	6.2	28.65	38.5	-9.85
		824.20	-6.87	H	25.11	2.87	6.2	28.44	38.5	-10.06
	190	836.60	-8.77	V	23.02	2.88	6.4	26.54	38.5	-11.96
		836.60	-7.98	H	23.81	2.88	6.4	27.33	38.5	-11.17
	251	848.80	-8.45	V	23.30	2.94	6.5	26.86	38.5	-11.64
		848.80	-8.20	H	23.55	2.94	6.5	27.11	38.5	-11.39

GPRS 1900

EUT Pol.	Channel	Frequency (MHz)	Reading level (dBuV)	Antenna Pol.	S.G. (dBm)	Cable loss (dB)	Ant.Gain (dBi)	Emission level (dBm)	Limit (dBm)	Margin (dB)
H	512	1850.20	-19.80	V	21.64	4.31	8.45	25.78	33	-7.22
		1850.20	-20.22	H	21.22	4.31	8.45	25.36	33	-7.64
	661	1880.00	-20.72	V	20.91	4.53	8.48	24.86	33	-8.14
		1880.00	-20.57	H	21.06	4.53	8.48	25.01	33	-7.99
	810	1909.80	-19.57	V	22.04	4.55	8.52	26.01	33	-6.99
		1909.80	-19.35	H	22.26	4.55	8.52	26.23	33	-6.77



OCCUPIED BANDWIDTH MEASUREMENT

LIMIT

According to §FCC 2.1049.

MEASUREMENT EQUIPMENT USED

Name of Equipment	Manufacturer	Model	Serial Number	Calibration Due
Spectrum Analyzer	Agilent	E4446A	MY44020154	08/16/2009
Wireless communication test set	Agilent	8960	QB44051695	10/06/2009

Remark: Each piece of equipment is scheduled for calibration once a year.

Test Configuration

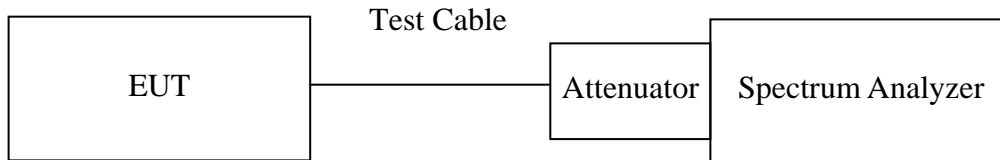

Remark: Measurement setup for testing on Antenna connector

TEST PROCEDURE

The EUT's output RF connector was connected with a short cable to the spectrum analyzer, RBW was set to about 1% of emission BW, VBW is set to 3 times the RBW, -26dBc display line was placed on the screen (or 99% bandwidth), the occupied bandwidth is the delta frequency between the two points where the display line intersects the signal trace.



TEST RESULTS

No non-compliance noted

Test Data

Test Mode	CH	Frequency (MHz)	Bandwidth (kHz)
GSM 850	128	824.20	240.81
	190	836.60	241.90
	251	848.80	240.08
GSM 1900	512	1850.20	243.21
	661	1880.00	242.63
	810	1909.80	240.30
GPRS 850	128	824.20	244.78
	190	836.60	241.55
	251	848.80	241.45
GPRS 1900	512	1850.20	243.95
	661	1880.00	245.71
	810	1909.80	241.65



Test Plot

GSM 850 (CH Low)

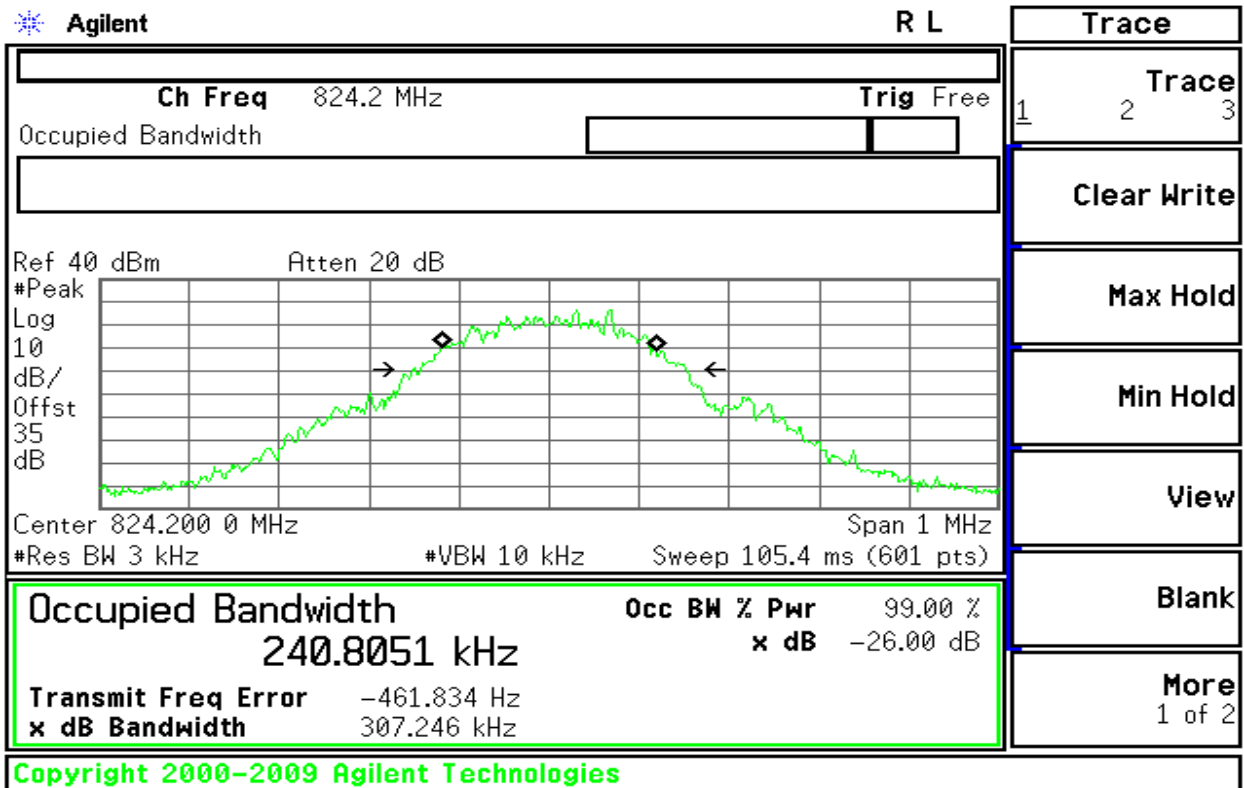

GSM 850 (CH Mid)

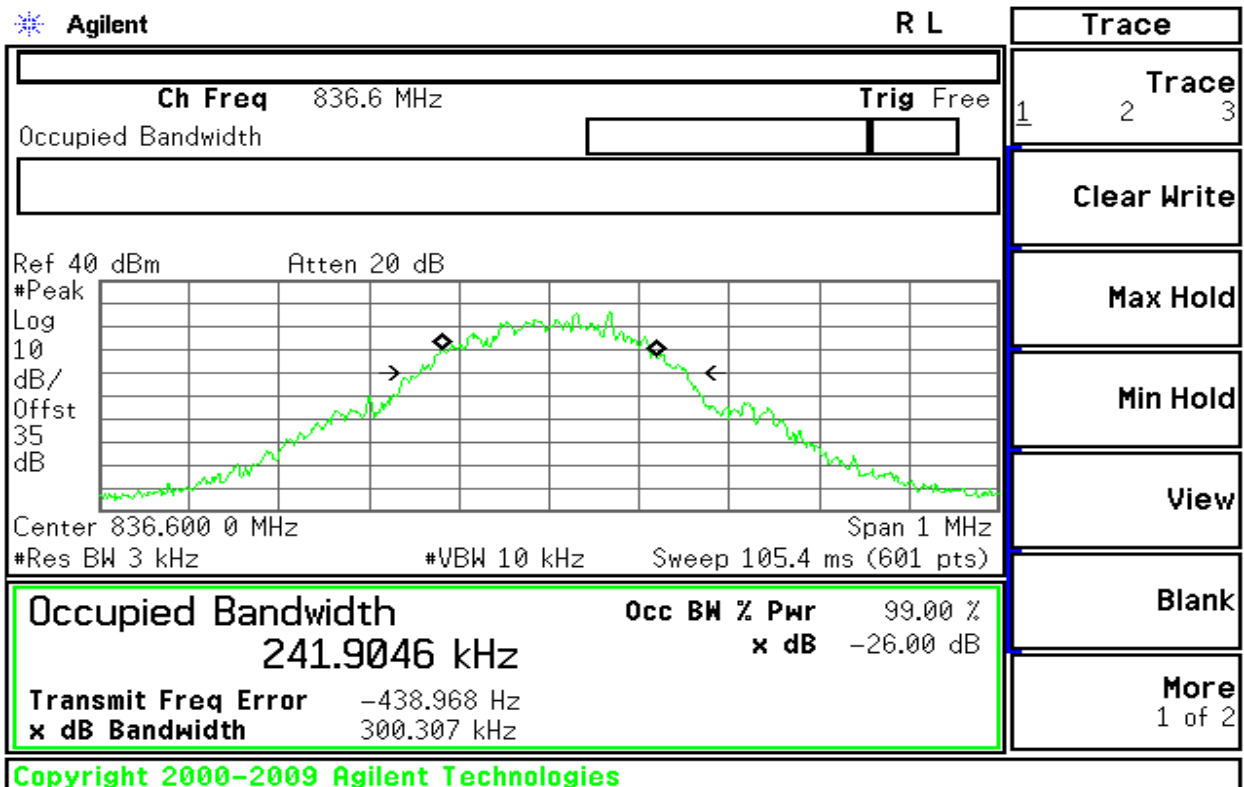



GSM 850 (CH High)

Agilent

R L

Trace

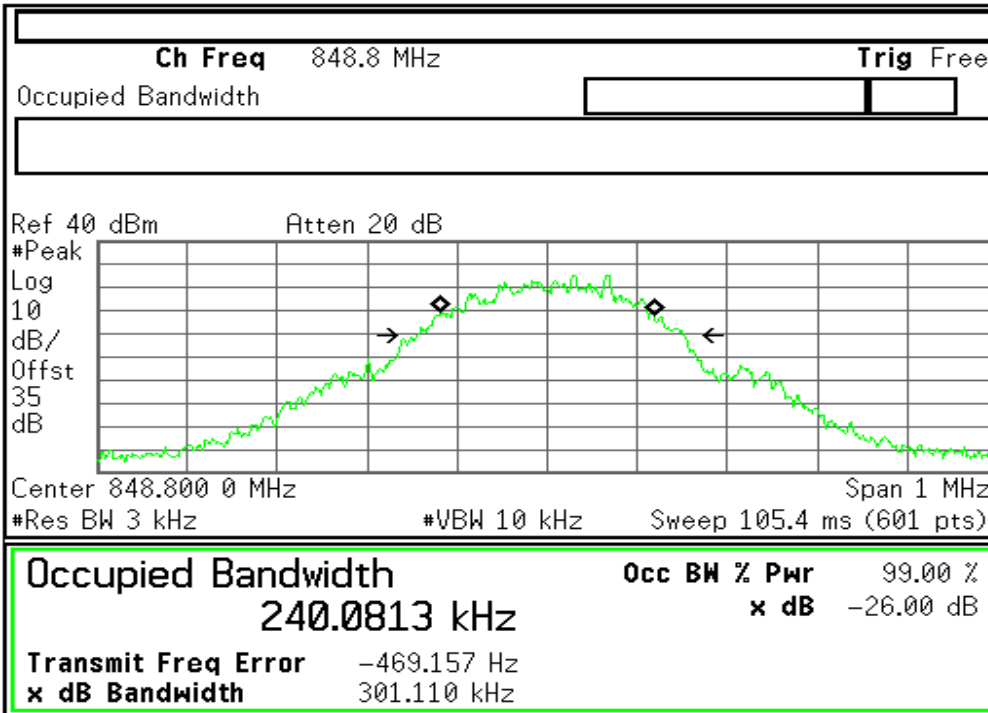

Trace	1	2	3
Clear Write			
Max Hold			
Min Hold			
View			
Blank			
More			1 of 2

Copyright 2000-2009 Agilent Technologies

GPRS 850 (CH Low)

Agilent

R L

Trace

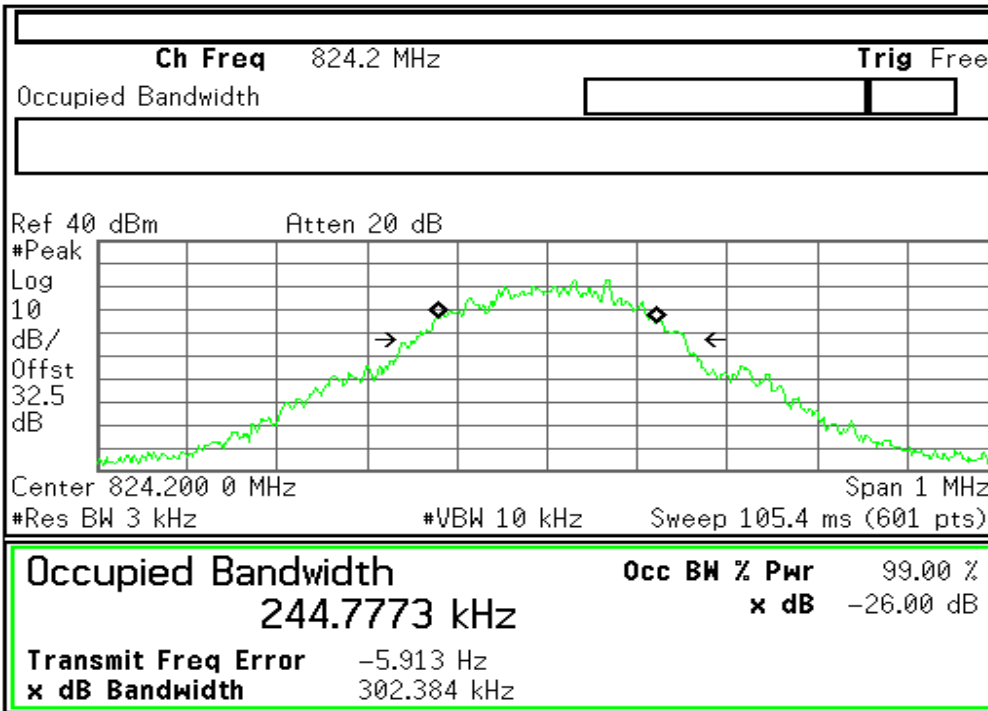

Trace	1	2	3
Clear Write			
Max Hold			
Min Hold			
View			
Blank			
More			1 of 2

Copyright 2000-2009 Agilent Technologies



GPRS 850 (CH Mid)

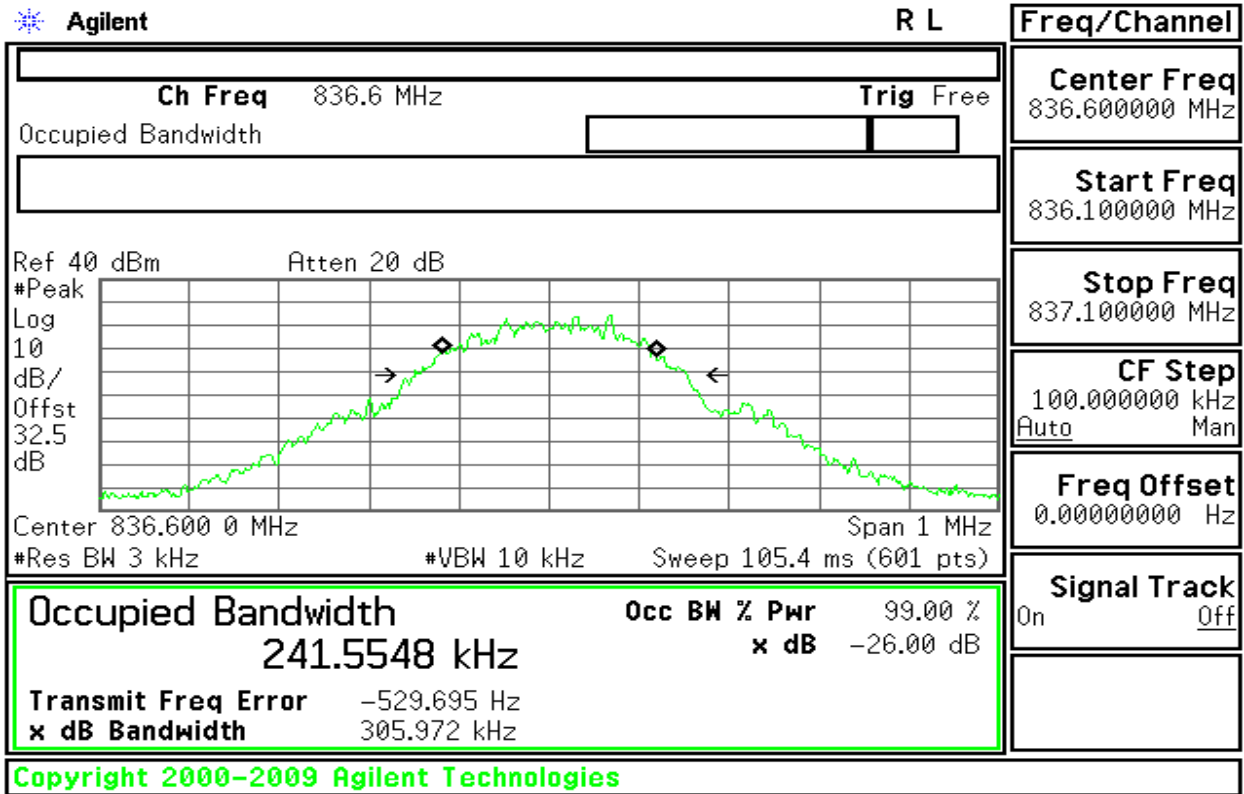

GPRS 850 (CH High)

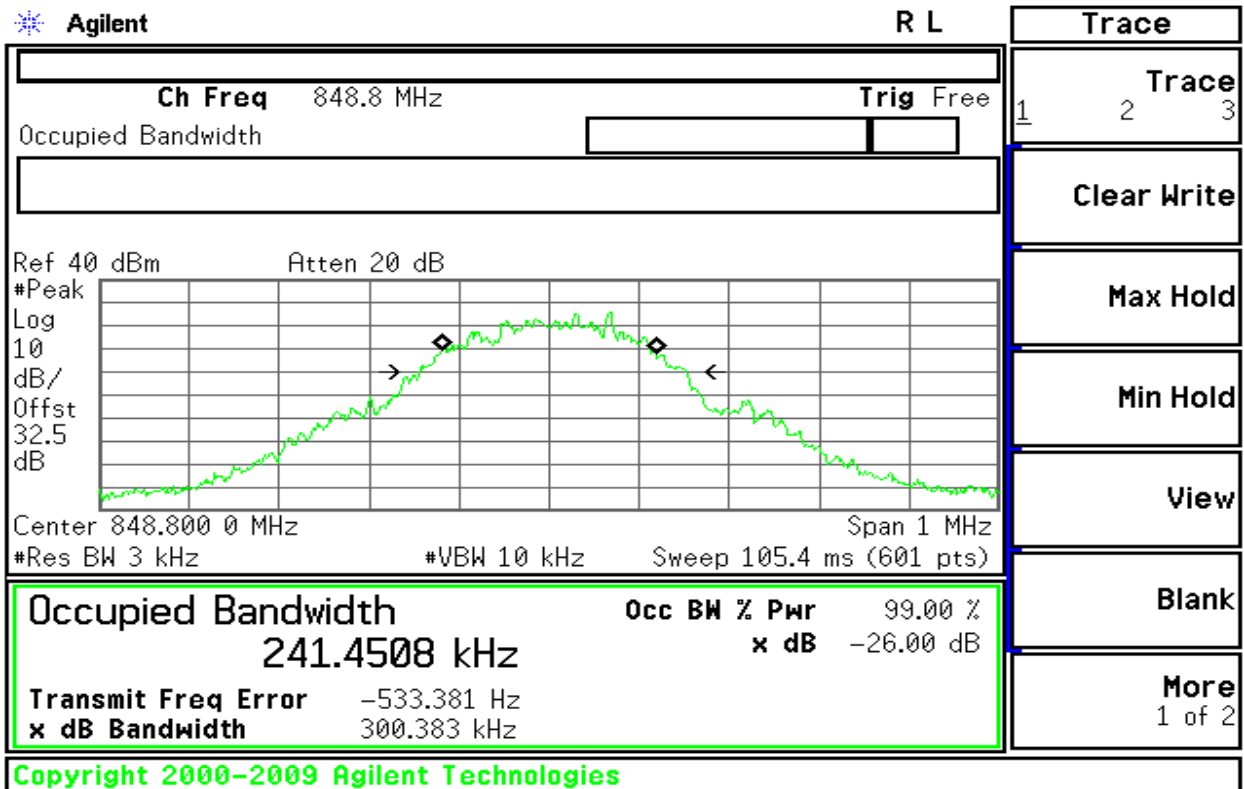



GSM 1900(CH Low)

Agilent

R L

Trace

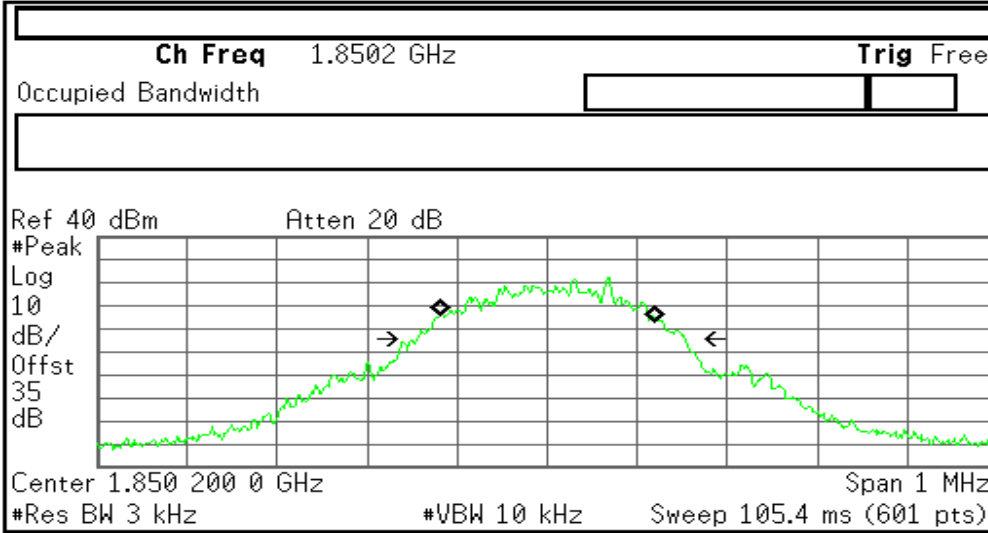

- Trace 1 2 3
- Clear Write
- Max Hold
- Min Hold
- View
- Blank
- More 1 of 2

Occupied Bandwidth	Occ BW % Pwr	99.00 %
243.2144 kHz	x dB	-26.00 dB
Transmit Freq Error		-34.925 Hz
x dB Bandwidth		301.125 kHz

Copyright 2000-2009 Agilent Technologies

GSM 1900 (CH Mid)

Agilent

R L

Trace

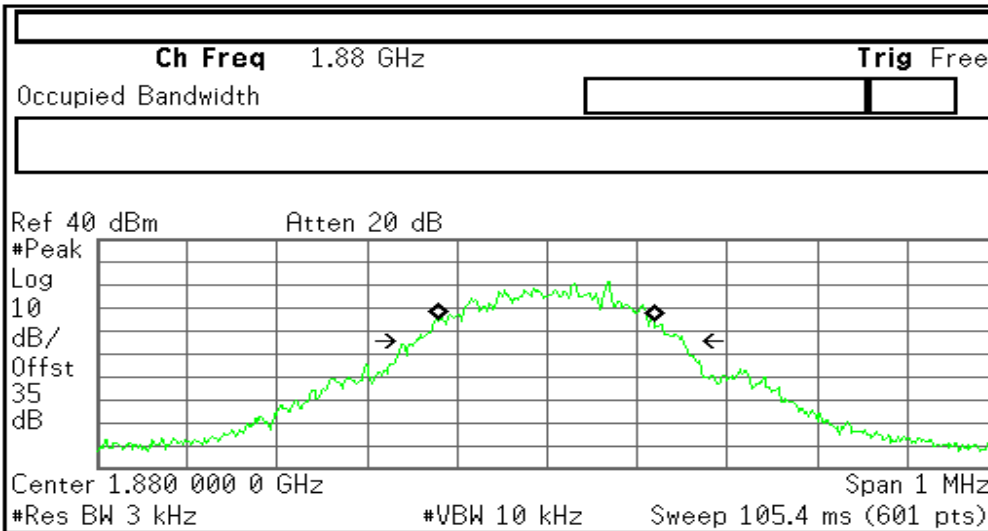

- Trace 1 2 3
- Clear Write
- Max Hold
- Min Hold
- View
- Blank
- More 1 of 2

Occupied Bandwidth	Occ BW % Pwr	99.00 %
242.6325 kHz	x dB	-26.00 dB
Transmit Freq Error		-1.158 kHz
x dB Bandwidth		301.173 kHz

Copyright 2000-2009 Agilent Technologies



GSM 1900 (CH High)

Agilent

R L

Trace

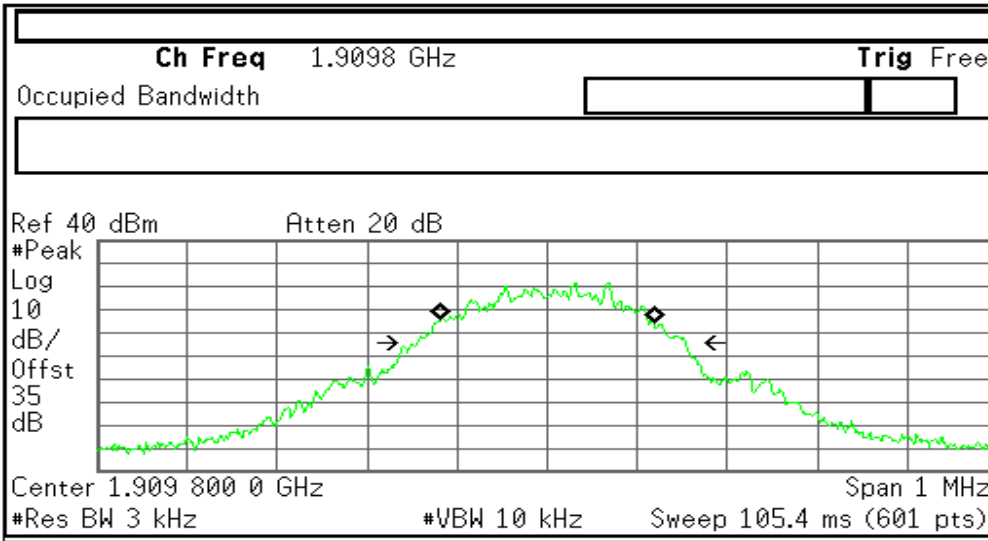

Trace
1 2 3
Clear Write
Max Hold
Min Hold
View
Blank
More 1 of 2

Occupied Bandwidth	Occ BW % Pwr	99.00 %
240.3083 kHz	x dB	-26.00 dB
Transmit Freq Error		-459.864 Hz
x dB Bandwidth		302.017 kHz

Copyright 2000-2009 Agilent Technologies

GPRS 1900(CH Low)

Agilent

R L

Meas Setup

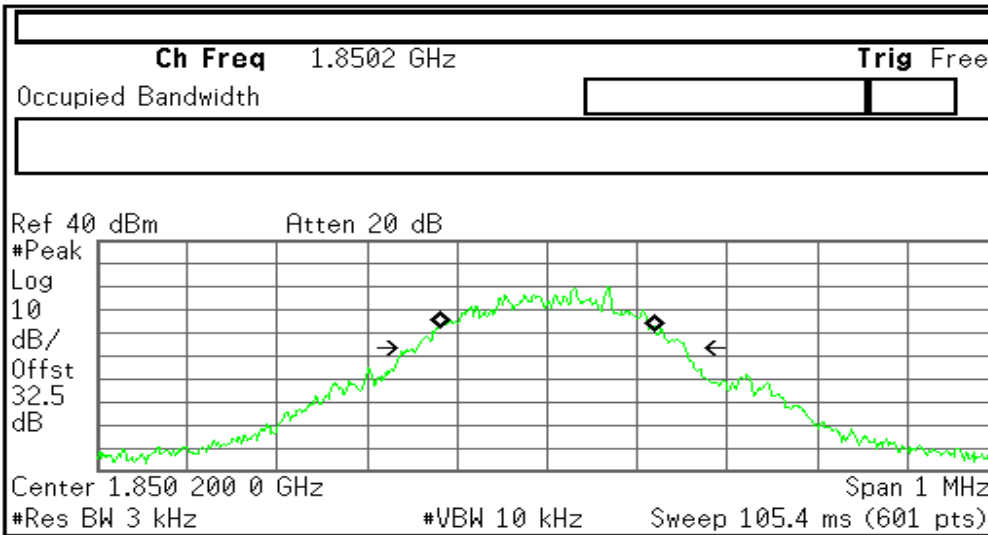

Avg Number
10
On Off
Avg Mode
Exp Repeat
Max Hold
On Off
Occ BW % Pwr
99.00 %
OBW Span
1.00000000 MHz
x dB
-26.00 dB
Optimize Ref Level

Occupied Bandwidth	Occ BW % Pwr	99.00 %
243.9506 kHz	x dB	-26.00 dB
Transmit Freq Error		-191.718 Hz
x dB Bandwidth		301.541 kHz

Copyright 2000-2009 Agilent Technologies



GPRS 1900 (CH Mid)

Agilent

R L

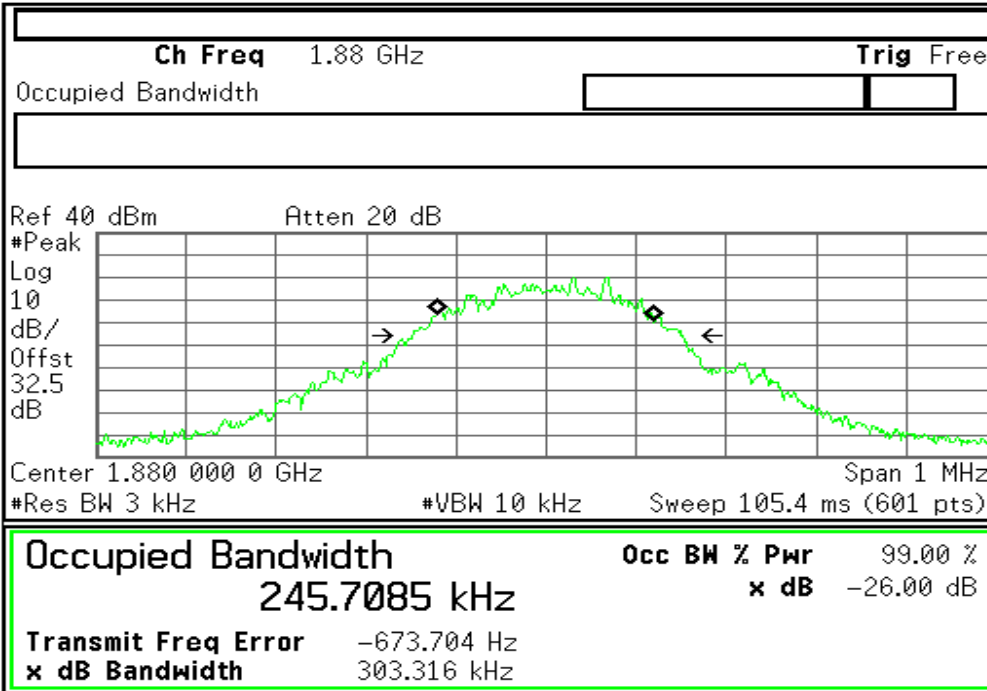

Meas Setup	
Avg Number	10
On	Off
Avg Mode	Repeat
Exp	
Max Hold	Off
On	
Occ BW % Pwr	99.00 %
OBW Span	1.00000000 MHz
x dB	-26.00 dB
Optimize Ref Level	

Copyright 2000-2009 Agilent Technologies

GPRS 1900 (CH High)

Agilent 06:15:53 Apr 8, 2009

R L

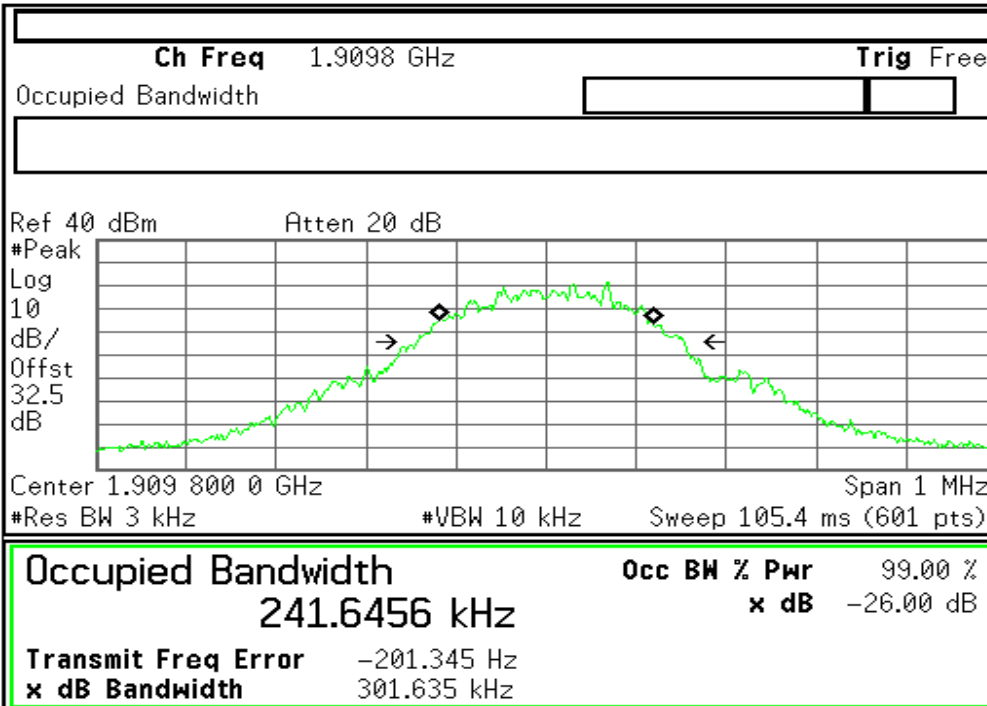

Freq/Channel	
Center Freq	1.90980000 GHz
Start Freq	1.90930000 GHz
Stop Freq	1.91030000 GHz
CF Step	100.000000 kHz
Auto	Man
Freq Offset	0.00000000 Hz
Signal Track	Off
On	Off

Copyright 2000-2009 Agilent Technologies



OUT OF BAND EMISSION AT ANTENNA TERMINALS

LIMIT

According to FCC §2.1051, FCC §2.2917(f), FCC §22.917(f), FCC §24.238(a).

Out of Band Emissions: The mean power of emission must be attenuated below the mean power of the non-modulated carrier (P) on any frequency twice or more than twice the fundamental frequency by at least $43 + 10 \log P$ dB.

Mobile Emissions in Base Frequency Range: The mean power of any emissions appearing in the base station frequency range from cellular mobile transmitters operated must be attenuated to a level not exceed -80 dBm at the transmit antenna connector.

Band Edge Requirements: In the 1MHz bands immediately outside and adjacent to the frequency block, a resolution bandwidth of at least 1% of the emission bandwidth of the fundamental emission of the transmitter may be employed to measure the Out of band Emission

MEASUREMENT EQUIPMENT USED

Name of Equipment	Manufacturer	Model	Serial Number	Calibration Due
Spectrum Analyzer	Agilent	E4446A	MY44020154	08/16/2009
Wireless communication test set	Agilent	8960	QB44051695	10/06/2009

Remark: Each piece of equipment is scheduled for calibration once a year.

TEST CONFIGURATION

Out of band emission at antenna terminals:

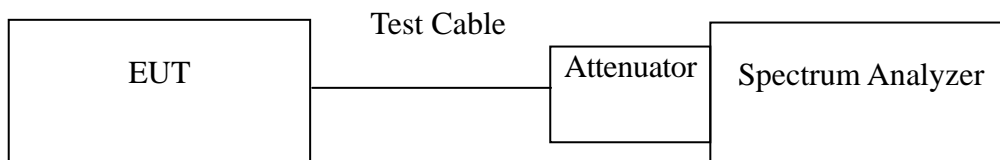

TEST PROCEDURE

The RF output of the transceiver was connected to a spectrum analyzer through appropriate attenuation. The resolution bandwidth of the spectrum analyzer was set at 1MHz, sufficient scans were taken to show the out of band Emissions if any up to 10th harmonic.

For the out of band: Set the RBW, VBW = 1MHz, Start=30MHz, Stop= 10 th harmonic. Limit = -13dBm

Band Edge Requirements (824 MHz and 849 MHz /1850MHz and 1910MHz): In the 1 MHz bands immediately outside and adjacent to the frequency block, a resolution bandwidth of at least 1 percent of the emission bandwidth of the fundamental emission of the transmitter may be employed to measure the out of band Emissions. Limit, -13dBm.

For the Band Edge: The spectrum analyzer is set to: RBW = 3 kHz, VBW = 10 kHz, Span = 1 MHz, Sweep = auto



TEST RESULTS

No non-compliance noted.

Test Data

Mode	CH	Location	Description
GSM 850	128	Figure 7-1	Conducted spurious emissions, 30MHz - 2.5GHz
		Figure 7-2	Conducted spurious emissions, 2.5GHz - 20GHz
	190	Figure 7-3	Conducted spurious emissions, 30MHz - 2.5GHz
		Figure 7-4	Conducted spurious emissions, 2.5GHz - 20GHz
	251	Figure 7-5	Conducted spurious emissions, 30MHz - 2.5GHz
		Figure 7-6	Conducted spurious emissions, 2.5GHz - 20GHz
GPRS 850	128	Figure 7-7	Conducted spurious emissions, 30MHz - 2.5GHz
		Figure 7-8	Conducted spurious emissions, 2.5GHz - 20GHz
	190	Figure 7-9	Conducted spurious emissions, 30MHz - 2.5GHz
		Figure 7-10	Conducted spurious emissions, 2.5GHz - 20GHz
	251	Figure 7-11	Conducted spurious emissions, 30MHz - 2.5GHz
		Figure 7-12	Conducted spurious emissions, 2.5GHz - 20GHz

Mode	CH	Location	Description
GSM 1900	512	Figure 8-1	Conducted spurious emissions, 30MHz - 2.5GHz
		Figure 8-2	Conducted spurious emissions, 2.5GHz - 20GHz
	661	Figure 8-3	Conducted spurious emissions, 30MHz - 2.5GHz
		Figure 8-4	Conducted spurious emissions, 2.5GHz - 20GHz
	810	Figure 8-5	Conducted spurious emissions, 30MHz - 2.5GHz
		Figure 8-6	Conducted spurious emissions, 2.5GHz - 20GHz
GPRS 1900	512	Figure 8-7	Conducted spurious emissions, 30MHz - 2.5GHz
		Figure 8-8	Conducted spurious emissions, 2.5GHz - 20GHz
	661	Figure 8-9	Conducted spurious emissions, 30MHz - 2.5GHz
		Figure 8-10	Conducted spurious emissions, 2.5GHz - 20GHz
	810	Figure 8-11	Conducted spurious emissions, 30MHz - 2.5GHz
		Figure 8-12	Conducted spurious emissions, 2.5GHz - 20GHz



Mode	CH	Location	Description
GSM 850	128	Figure 9-1	Band Edge emissions
	251	Figure 9-2	Band Edge emissions
GPRS 850	128	Figure 9-3	Band Edge emissions
	251	Figure 9-4	Band Edge emissions

Mode	CH	Location	Description
GSM 1900	512	Figure 10-1	Band Edge emissions
	810	Figure 10-2	Band Edge emissions
GPRS 1900	512	Figure 10-3	Band Edge emissions
	810	Figure 10-4	Band Edge emissions



Test Plot

GSM 850

Figure 7-1: Out of Band emission at antenna terminals – GSM CH Low

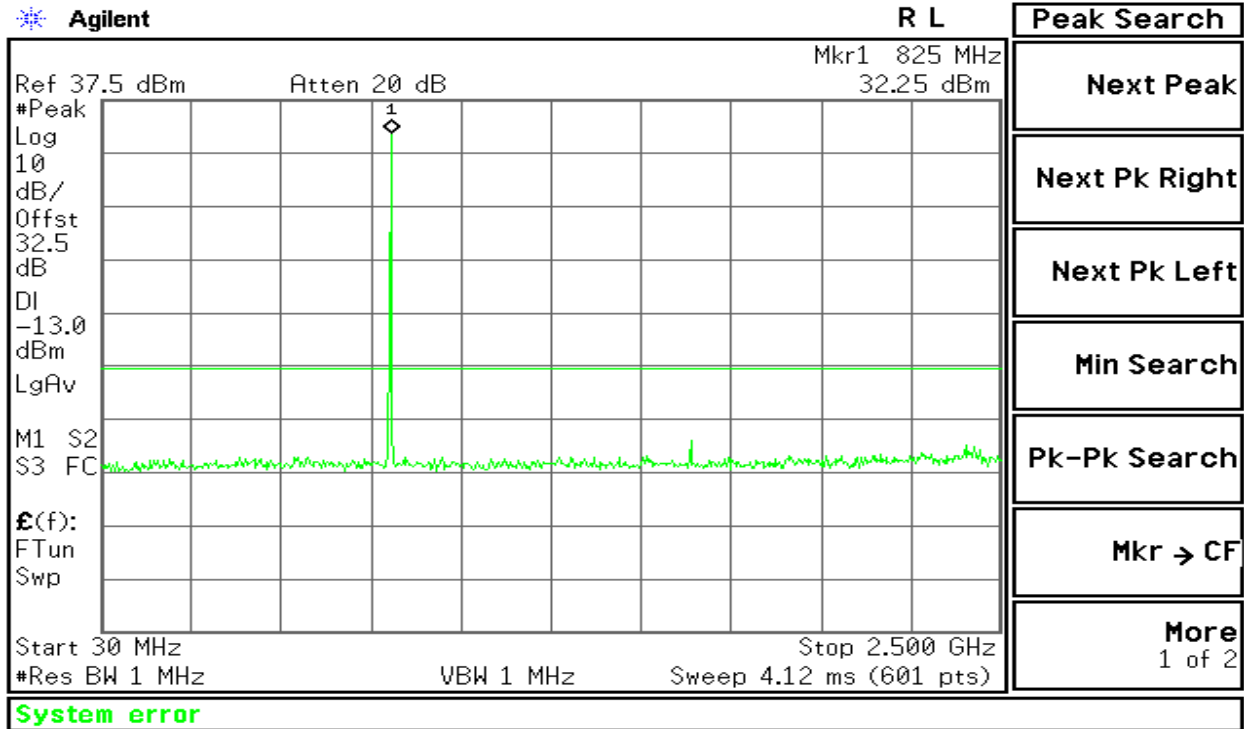

Figure 7-2: Out of Band emission at antenna terminals – GSM CH Low

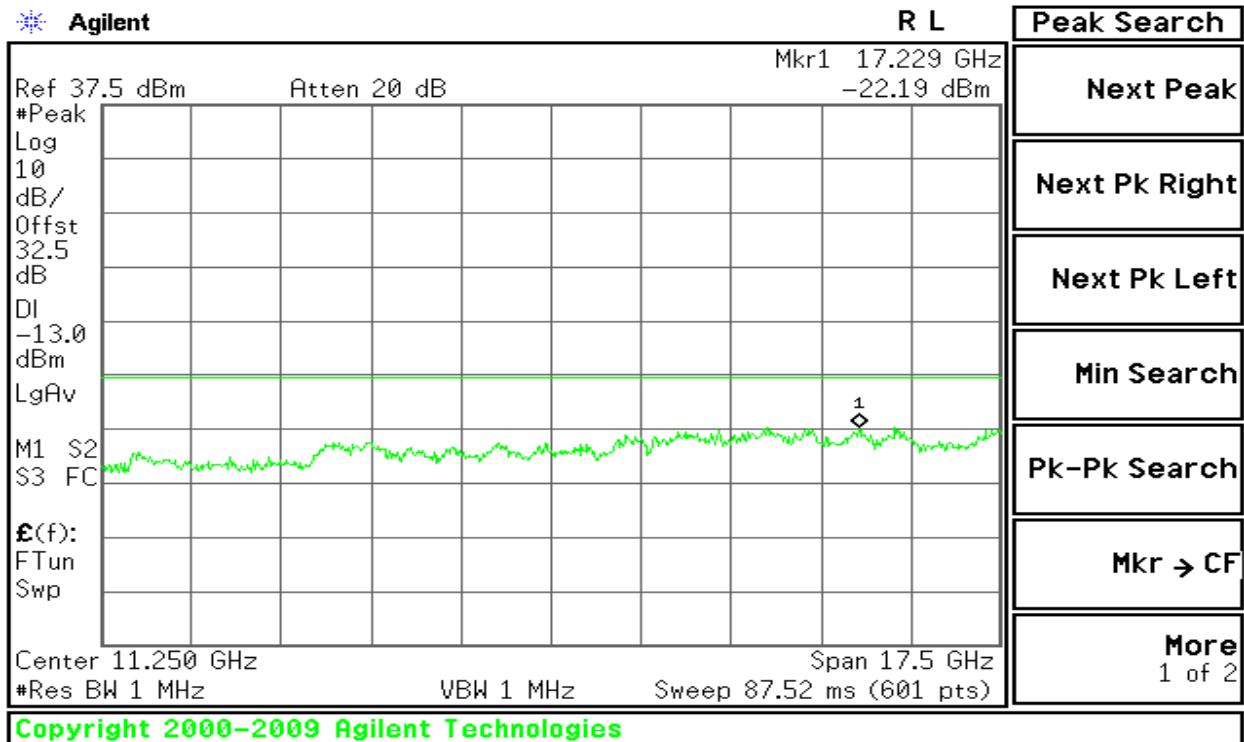

Figure 7-3: Out of Band emission at antenna terminals – GSM CH Mid

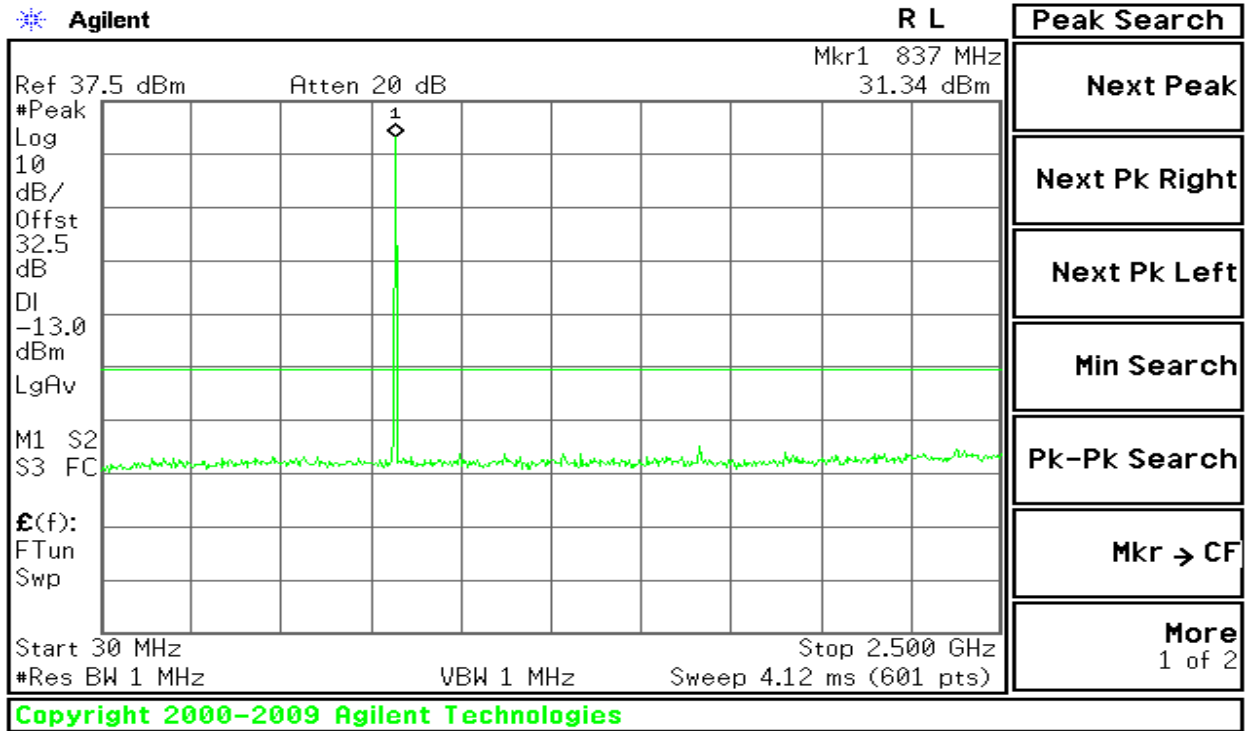

Figure 7-4: Out of Band emission at antenna terminals – GSM CH Mid

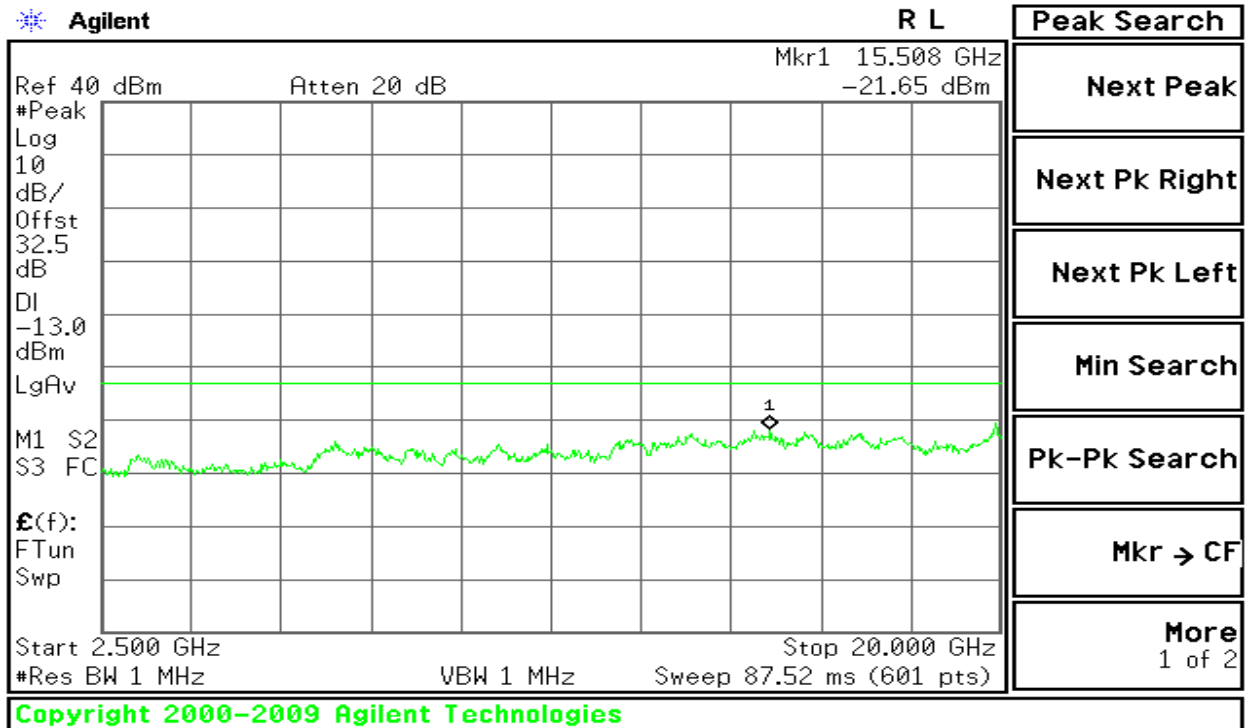

Figure 7-5: Out of Band emission at antenna terminals – GSM CH High

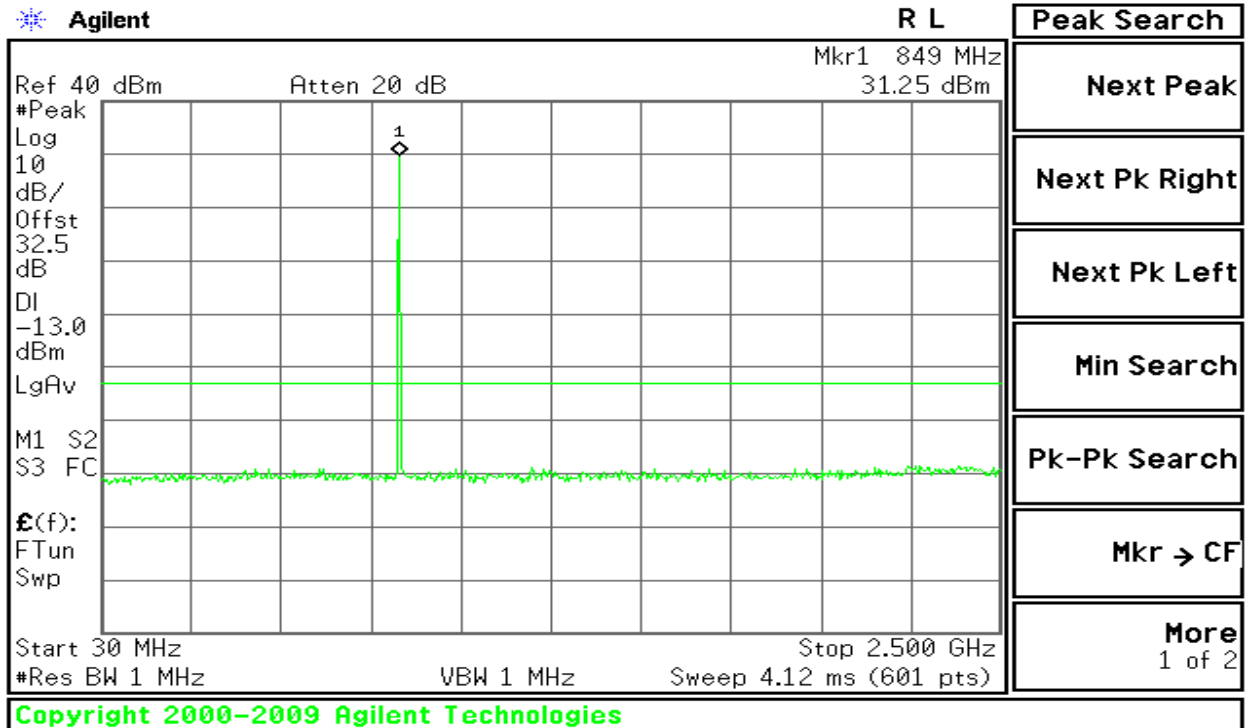
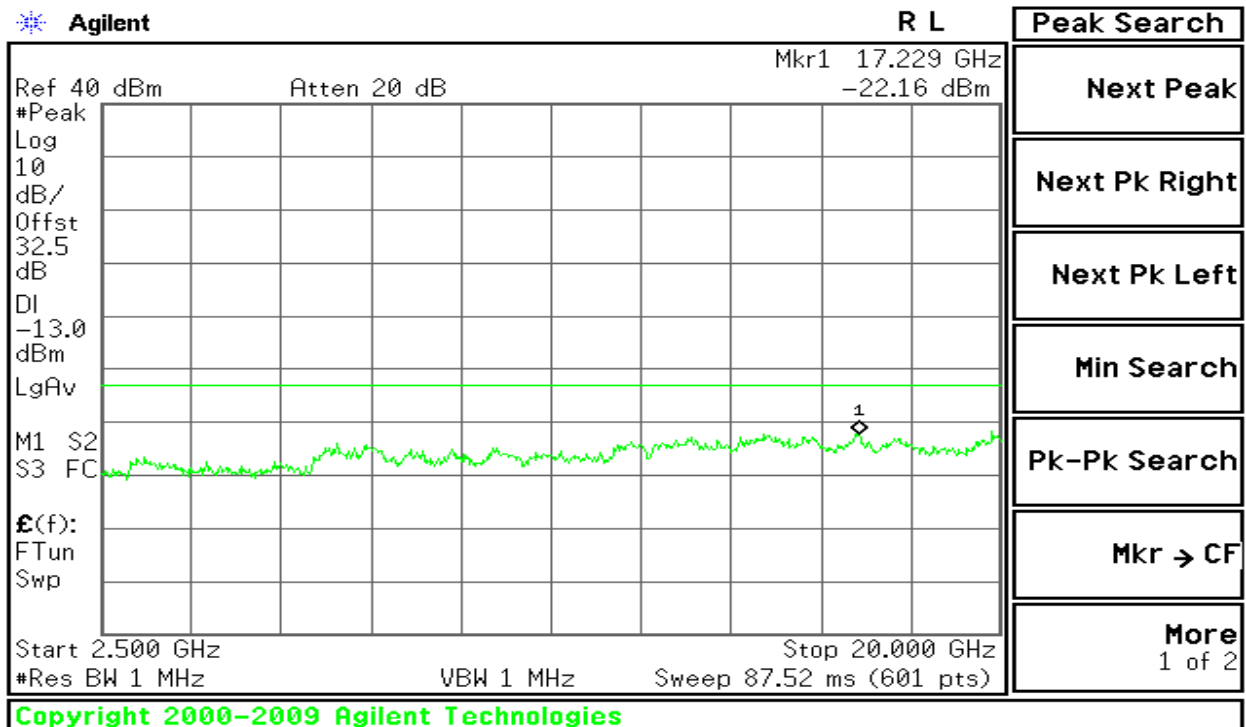

Figure 7-6: Out of Band emission at antenna terminals – GSM CH High



GPRS 850

Figure 7-7: Out of Band emission at antenna terminals – GSM CH Low

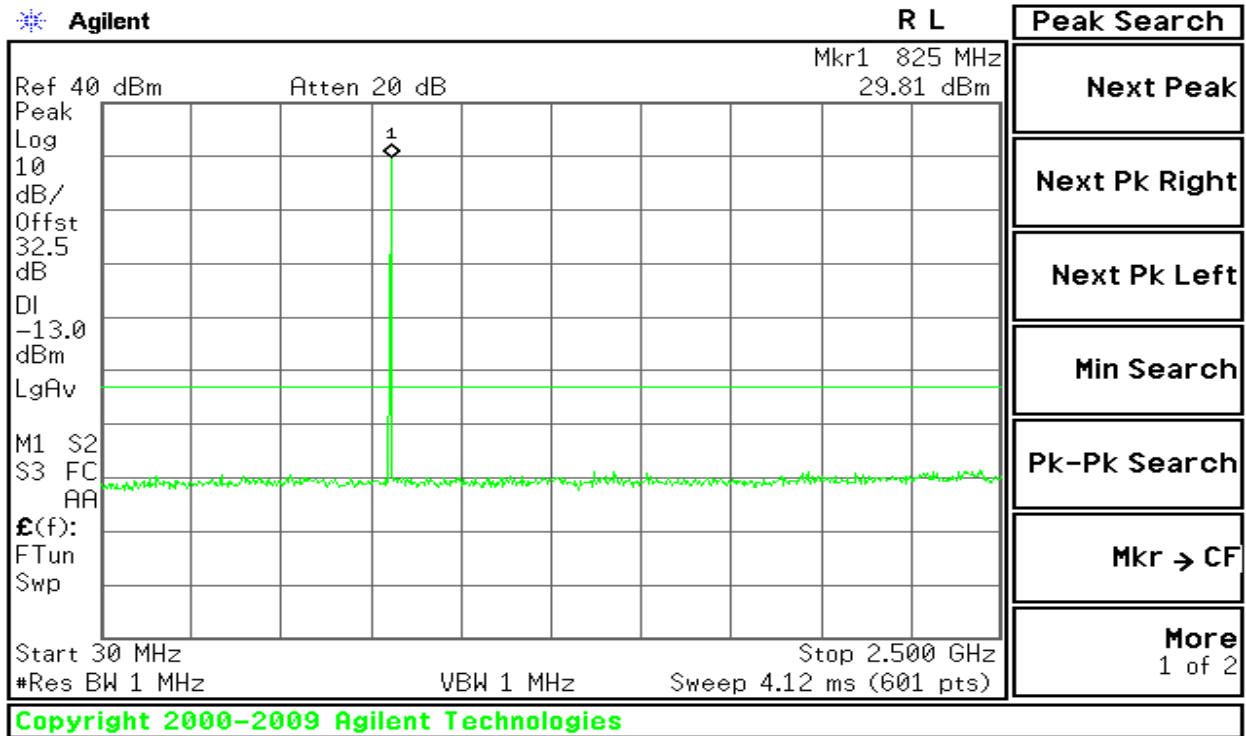

Figure 7-8: Out of Band emission at antenna terminals – GSM CH Low

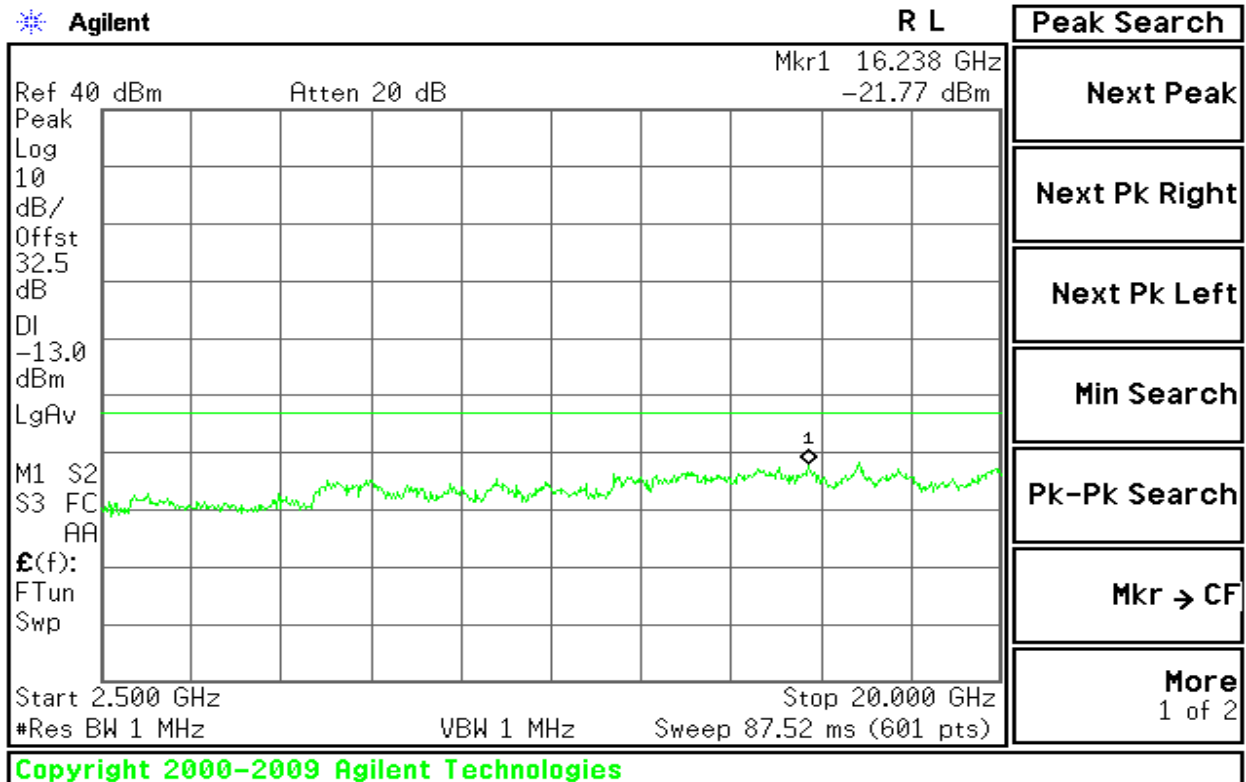

Figure 7-9: Out of Band emission at antenna terminals – GSM CH Middle

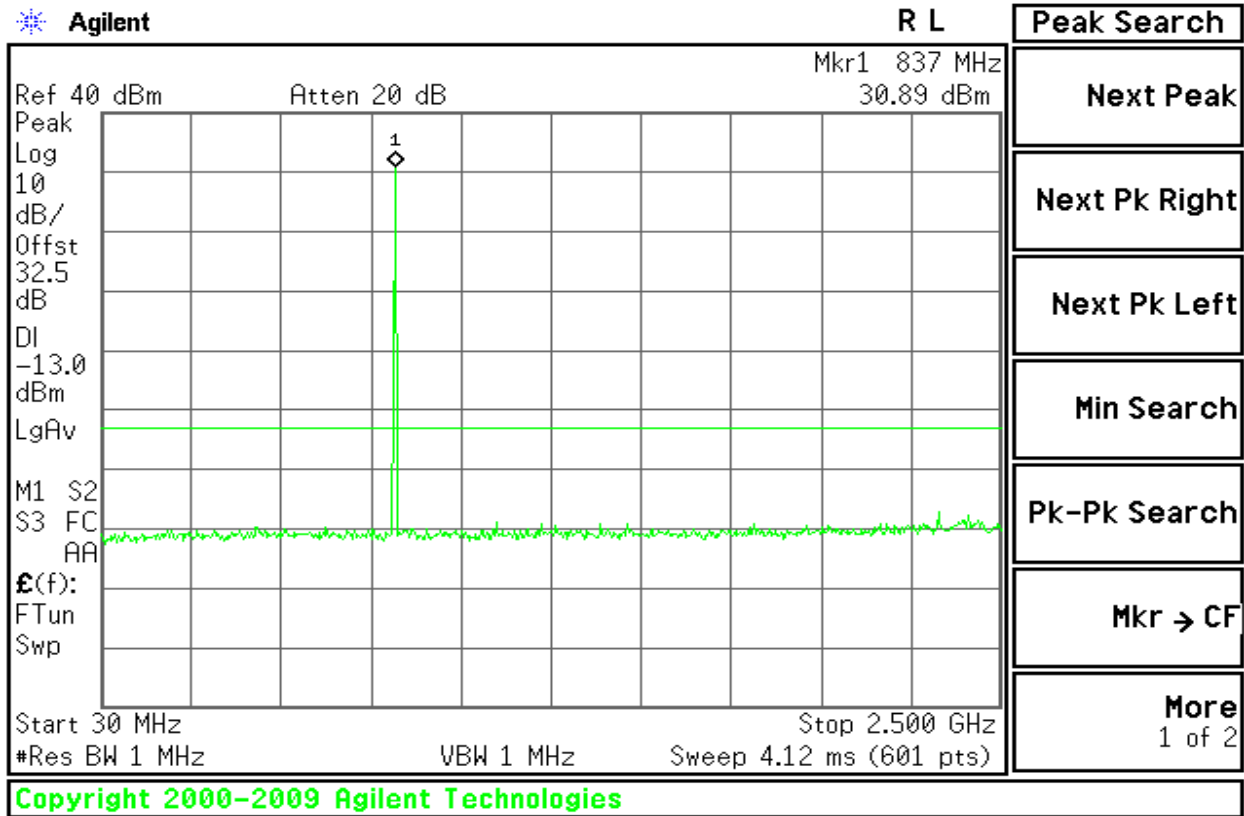

Figure 7-10: Out of Band emission at antenna terminals – GSM CH Middle

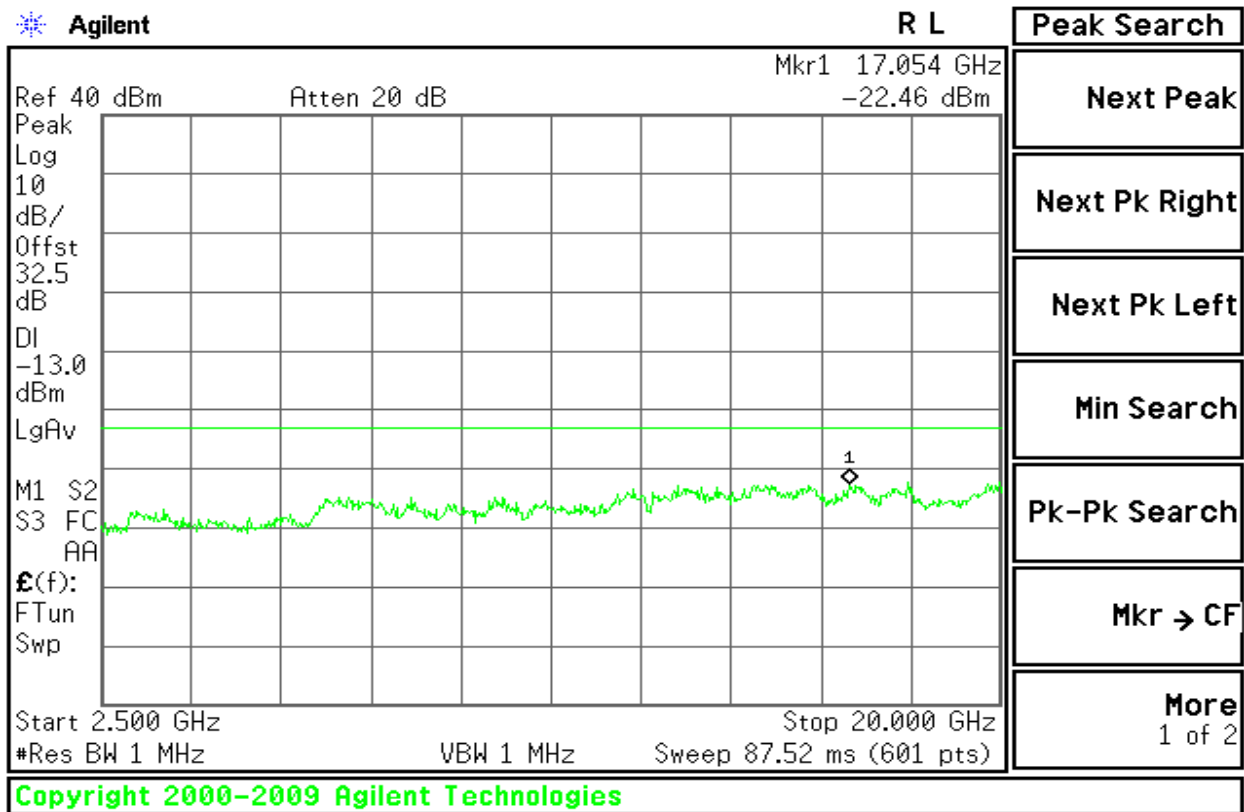



Figure 7-11: Out of Band emission at antenna terminals – GSM CH High

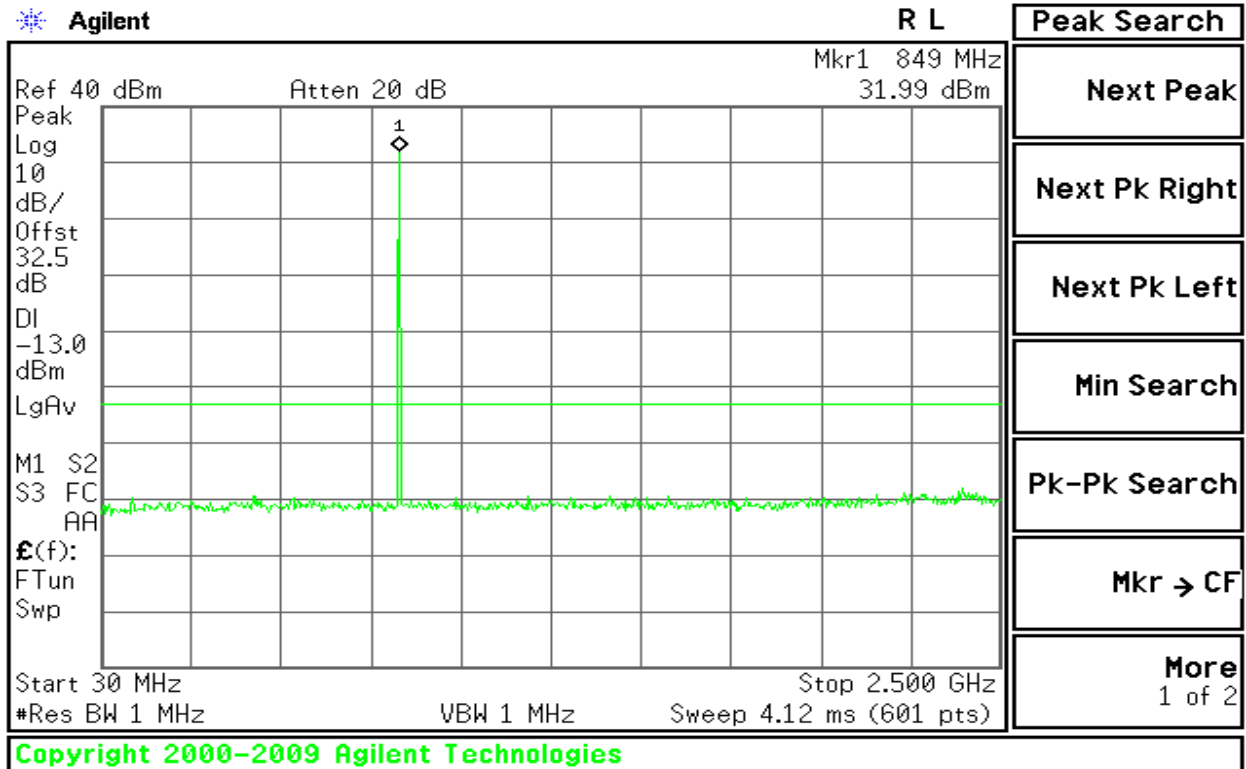
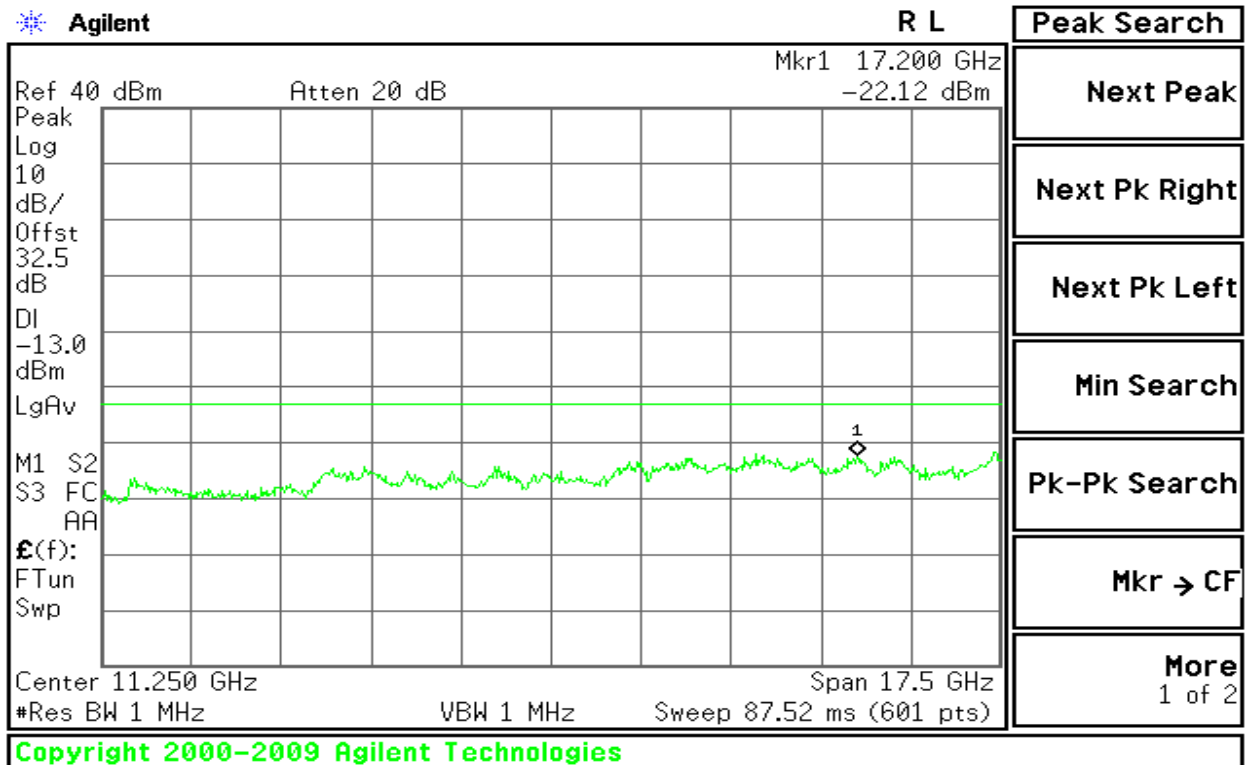

Figure 7-12: Out of Band emission at antenna terminals – GSM CH High





GSM 1900

Figure 8-1: Out of Band emission at antenna terminals – GSM CH Low

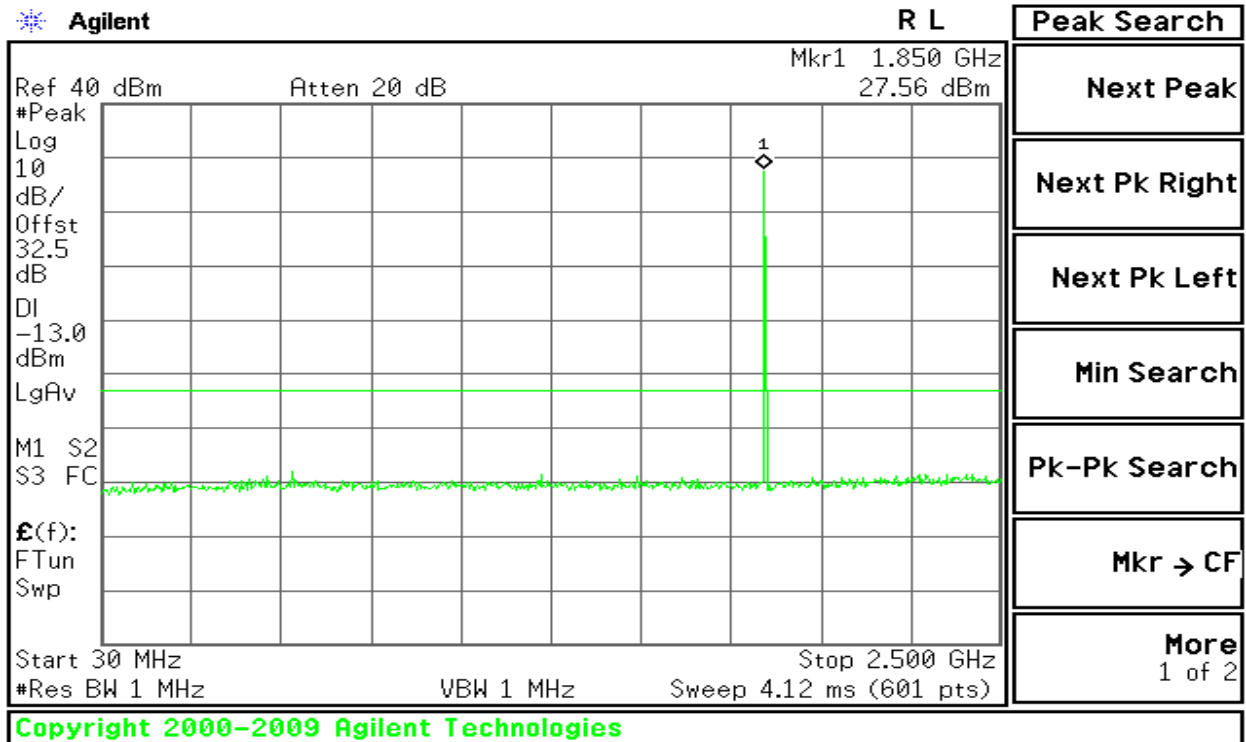

Figure 8-2: Out of Band emission at antenna terminals – GSM CH Low

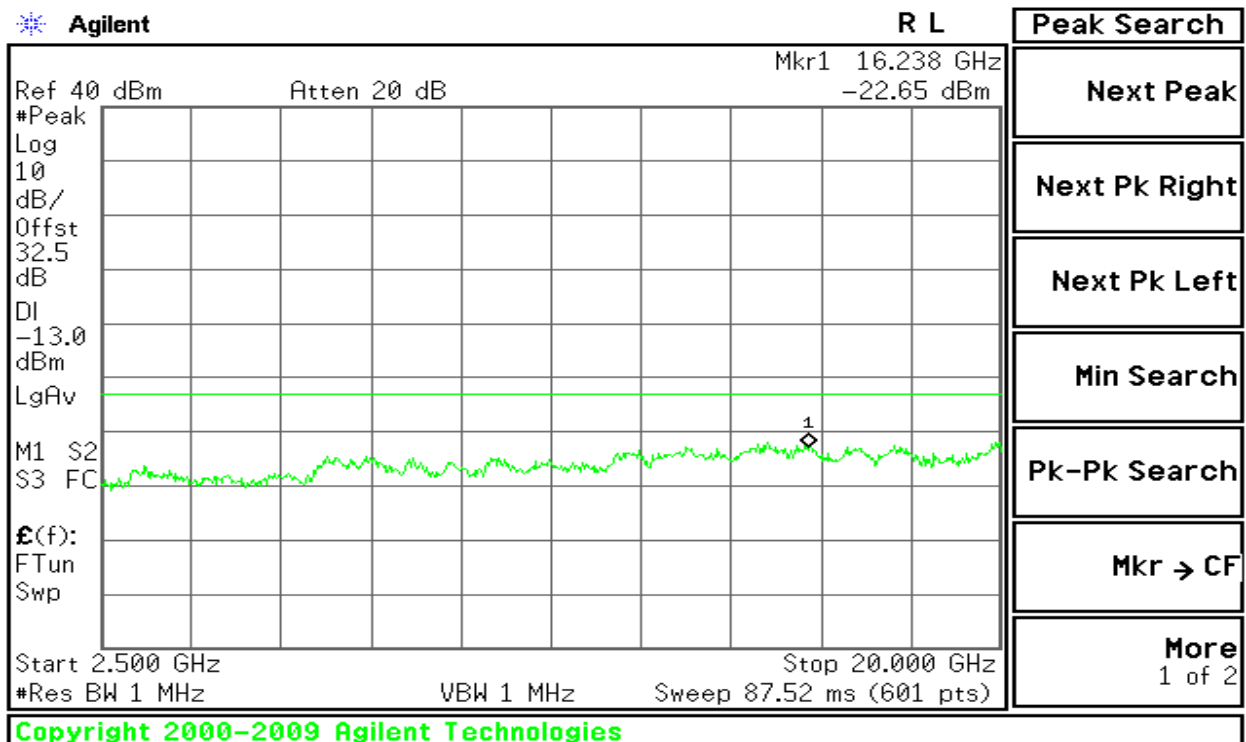



Figure 8-3: Out of Band emission at antenna terminals – GSM CH Mid

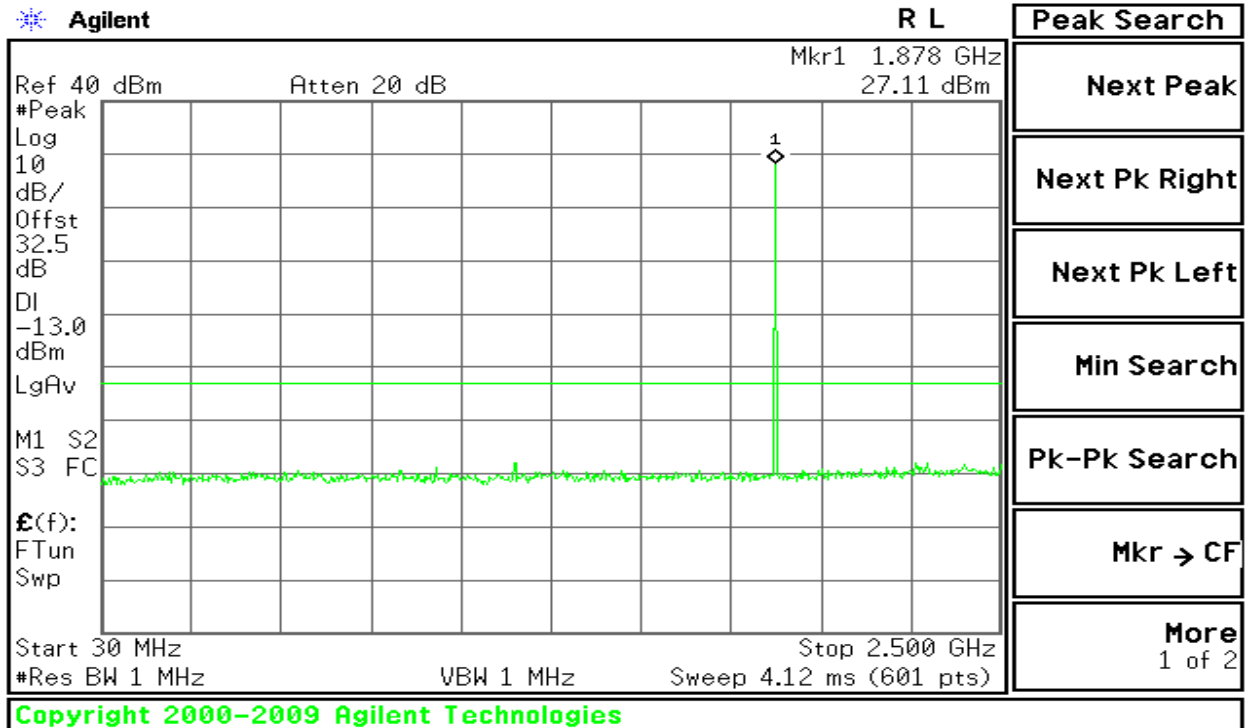

Figure 8-4: Out of Band emission at antenna terminals – GSM CH Mid

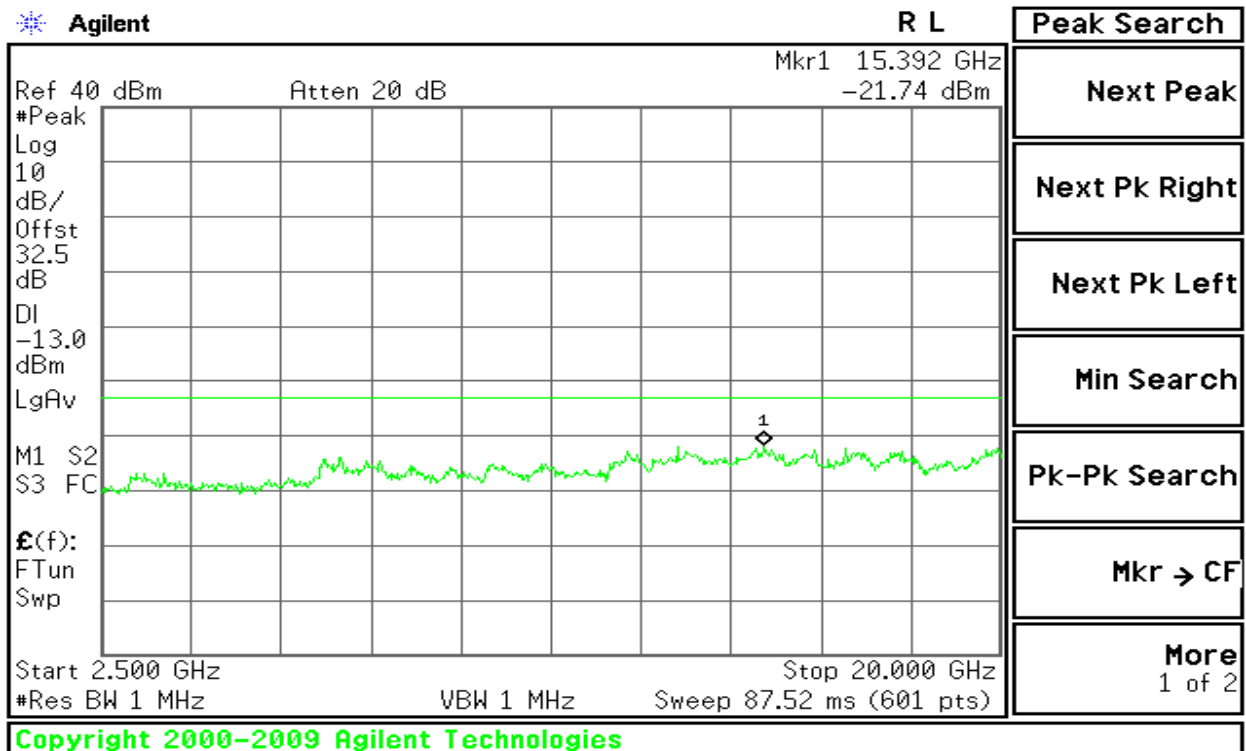

Figure 8-5: Out of Band emission at antenna terminals – GSM CH High

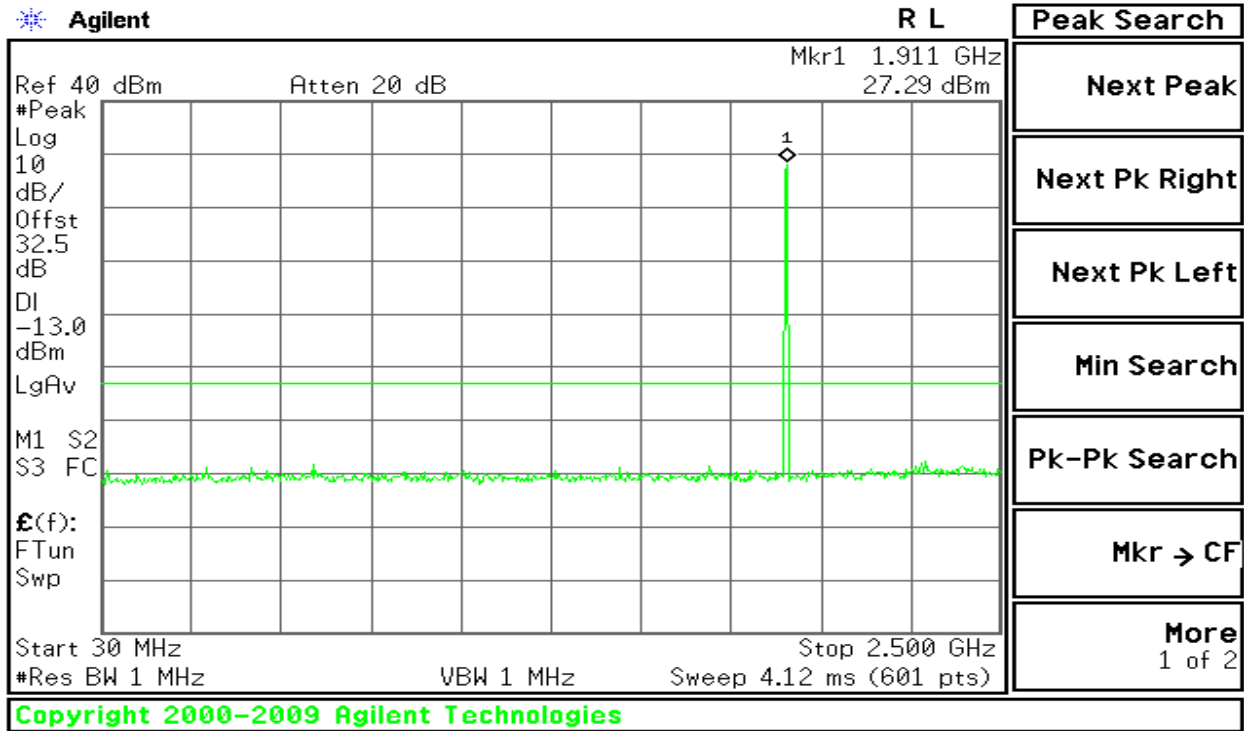
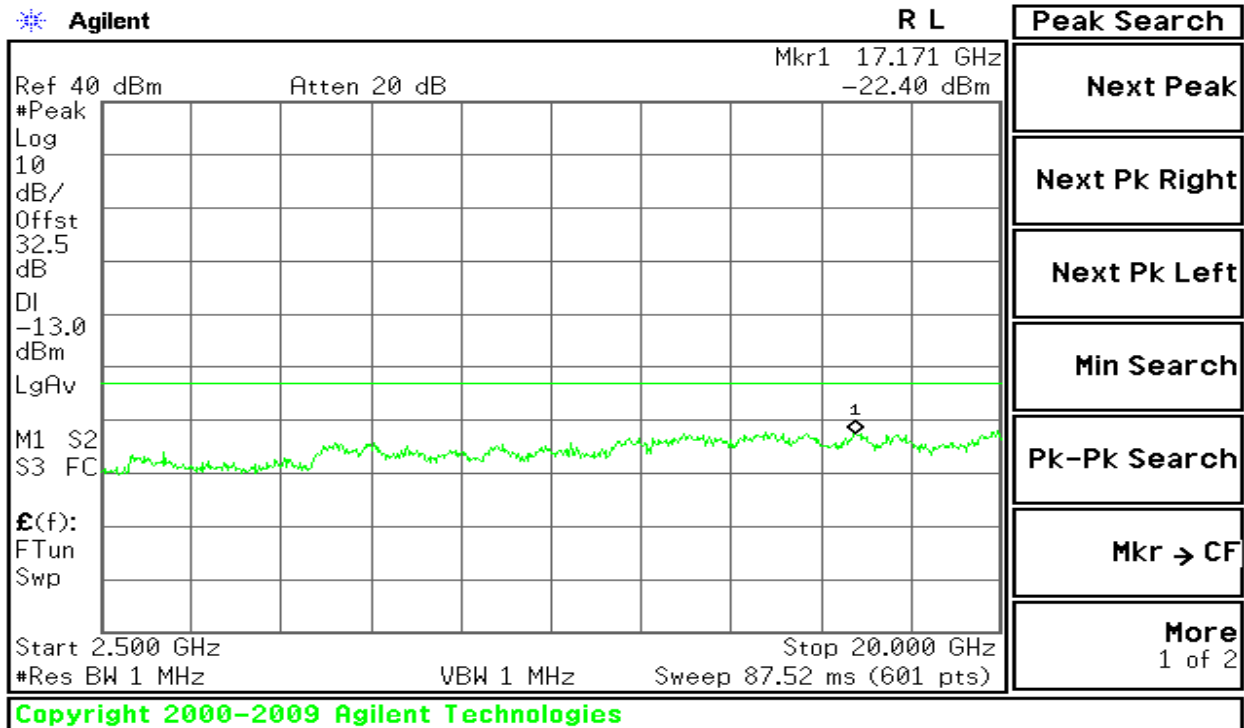

Figure 8-6: Out of Band emission at antenna terminals – GSM CH High



GPRS 1900

Figure 8-7: Out of Band emission at antenna terminals – GSM CH Low

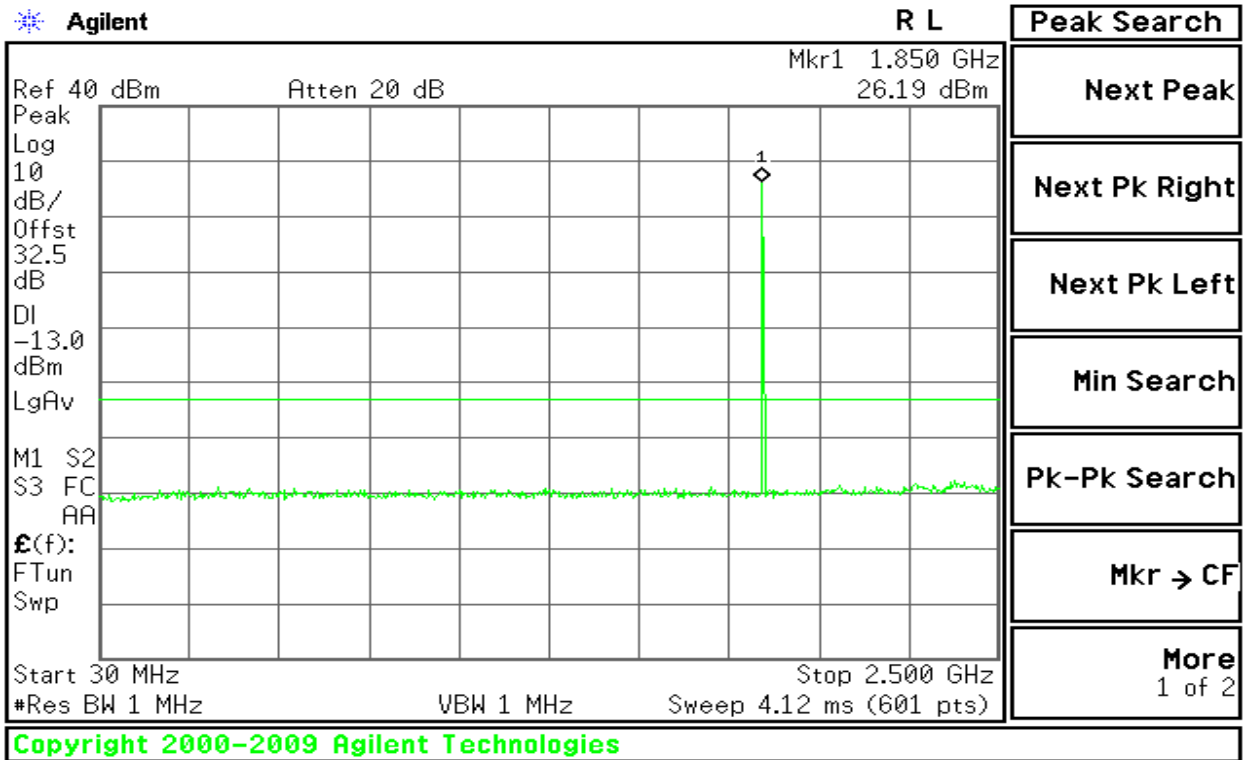

Figure 8-8: Out of Band emission at antenna terminals – GSM CH Low

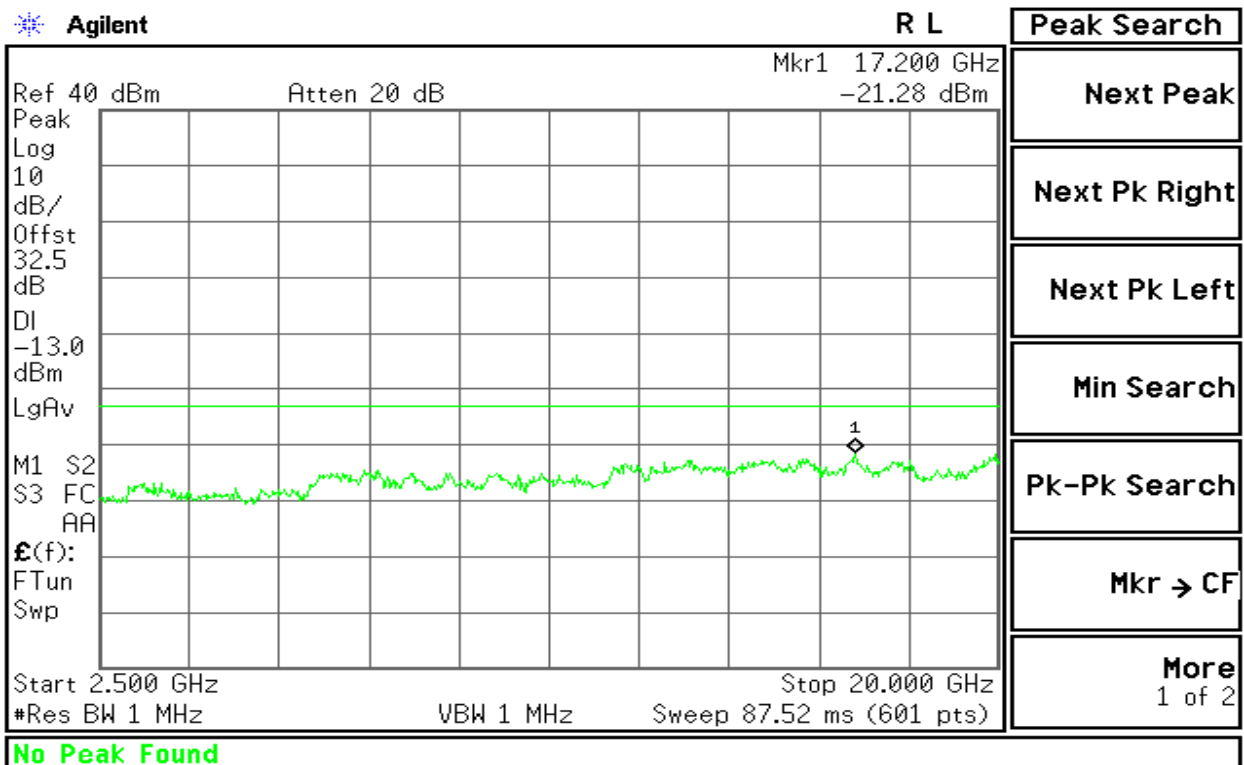



Figure 8-9: Out of Band emission at antenna terminals – GSM CH Middle

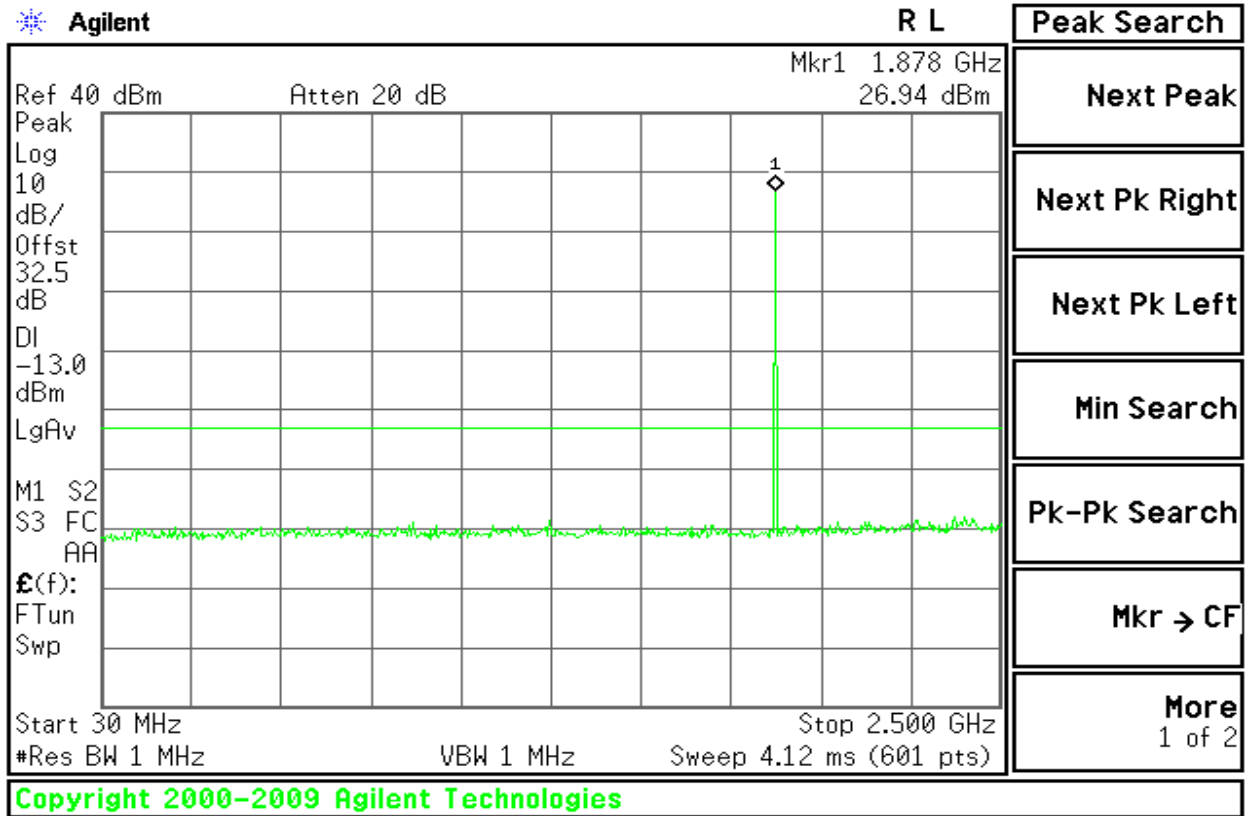

Figure 8-10: Out of Band emission at antenna terminals – GSM CH Middle

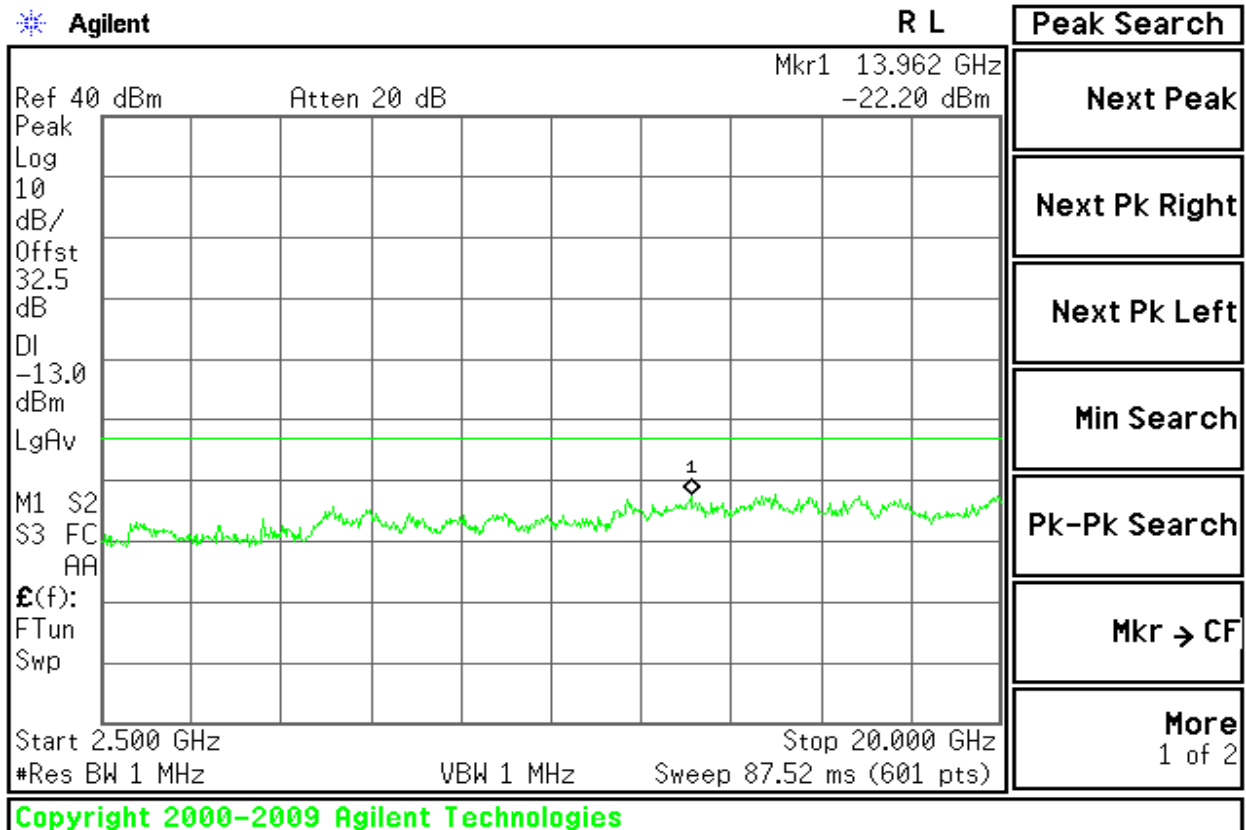



Figure 8-11: Out of Band emission at antenna terminals – GSM CH High

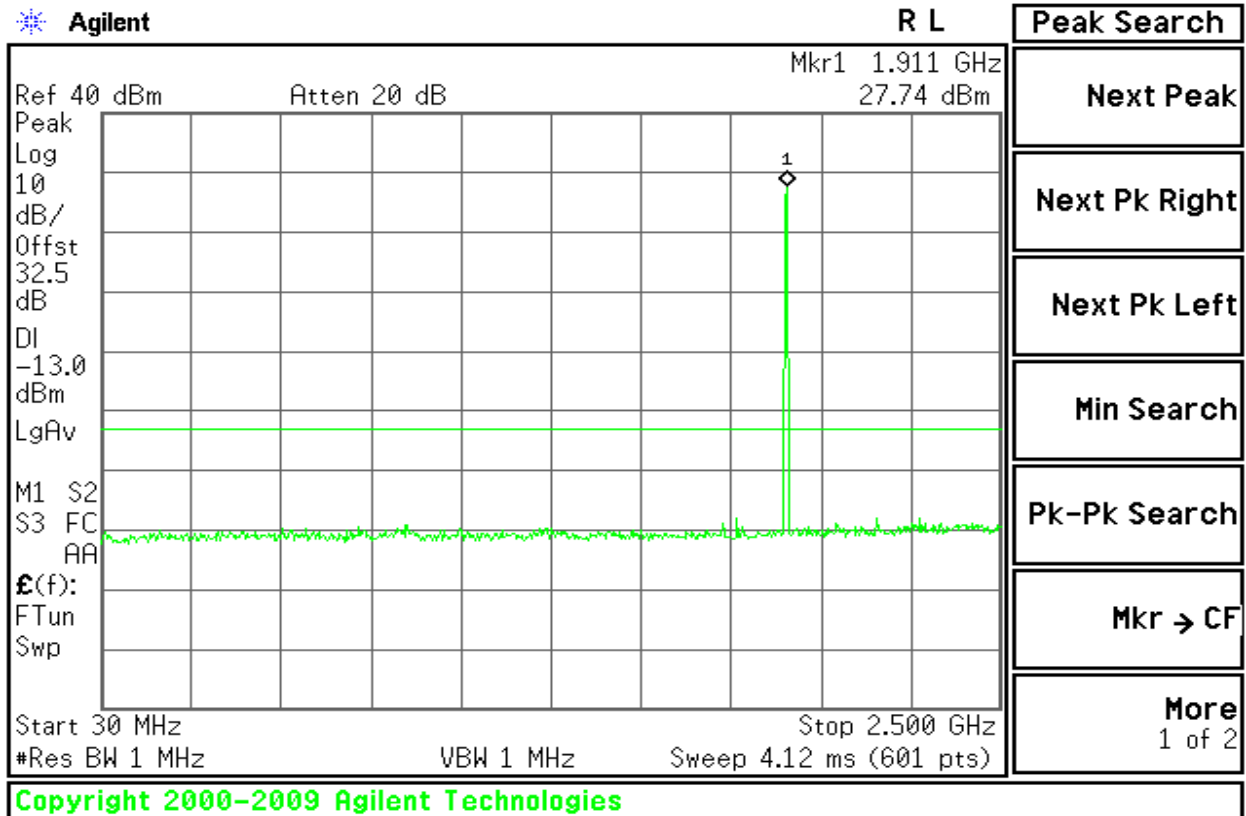
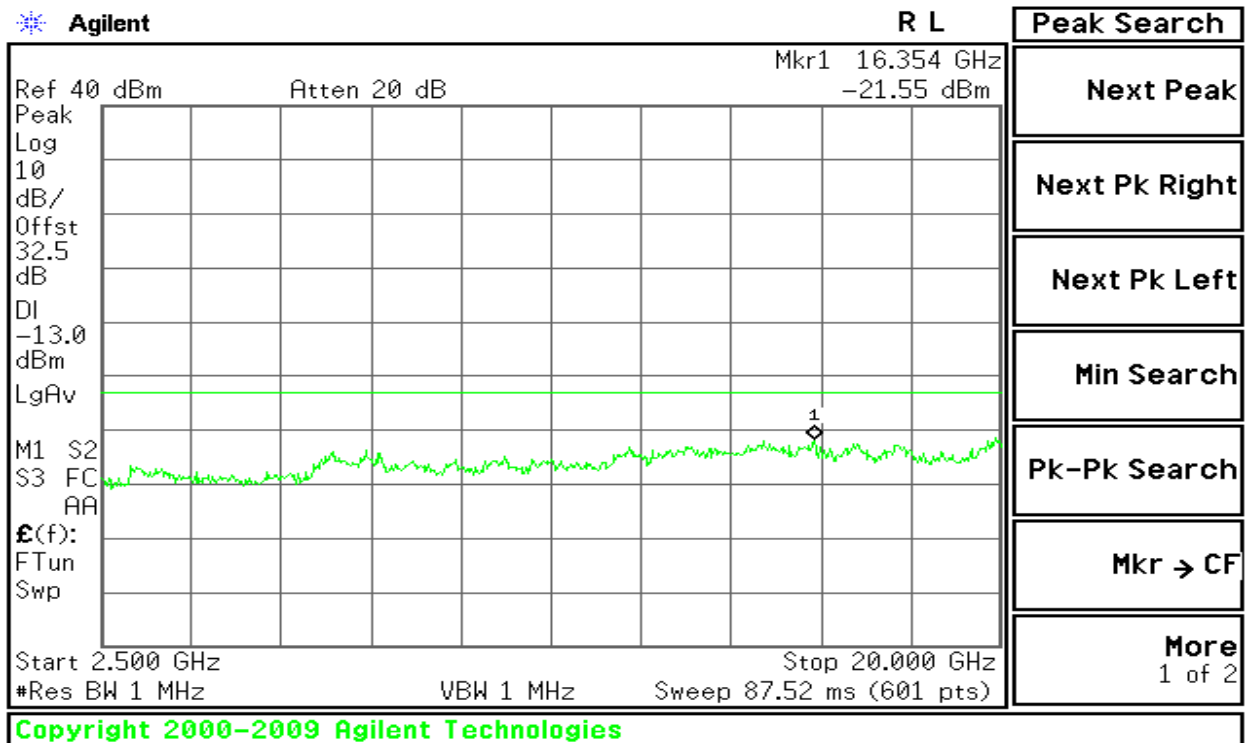

Figure 8-12: Out of Band emission at antenna terminals – GSM CH High



GSM 850

Figure 9-1: Band Edge emissions – GSM CH Low

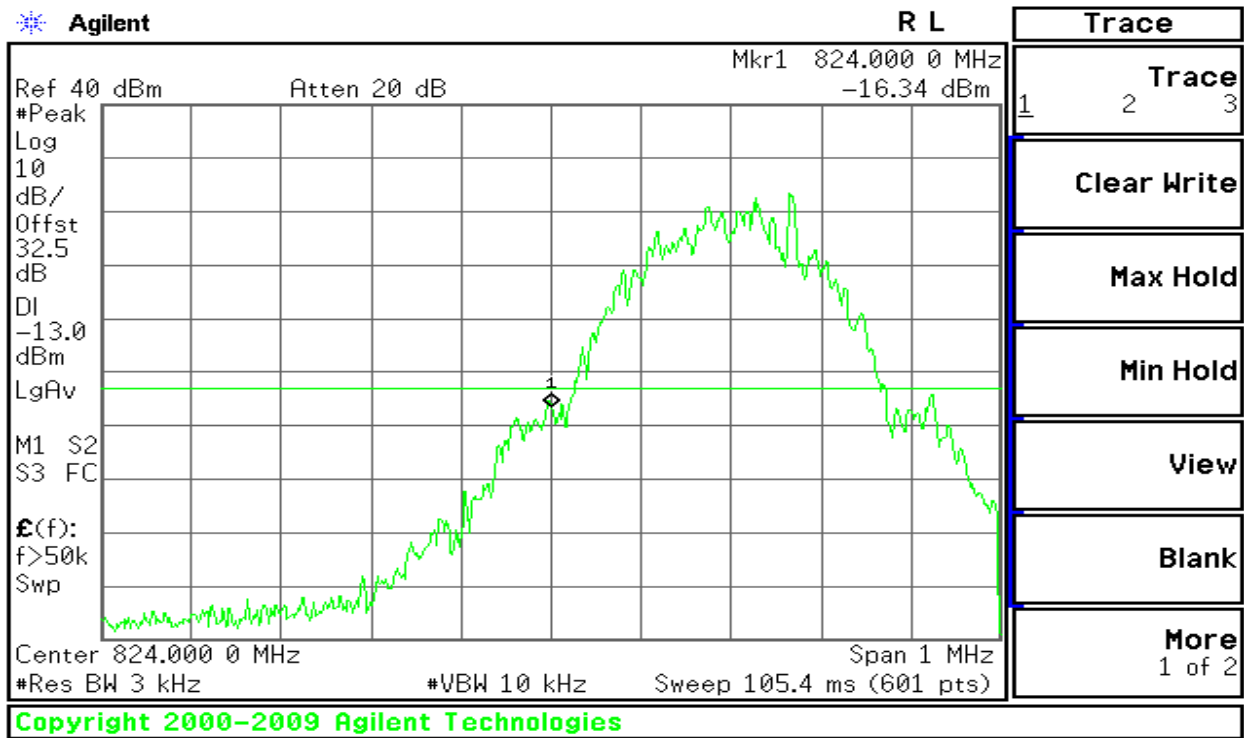
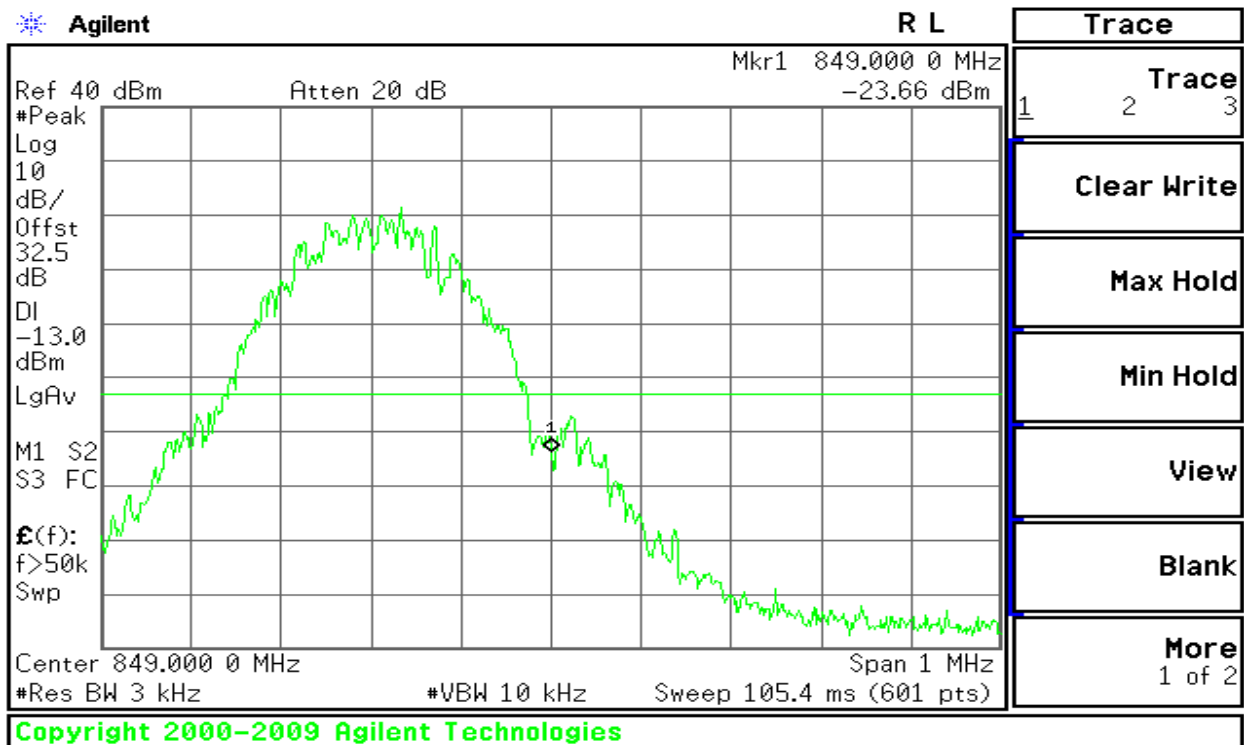

Figure 9-2: Band Edge emissions – GSM CH High





GPRS 850

Figure 9-3: Band Edge emissions – GPRS CH Low

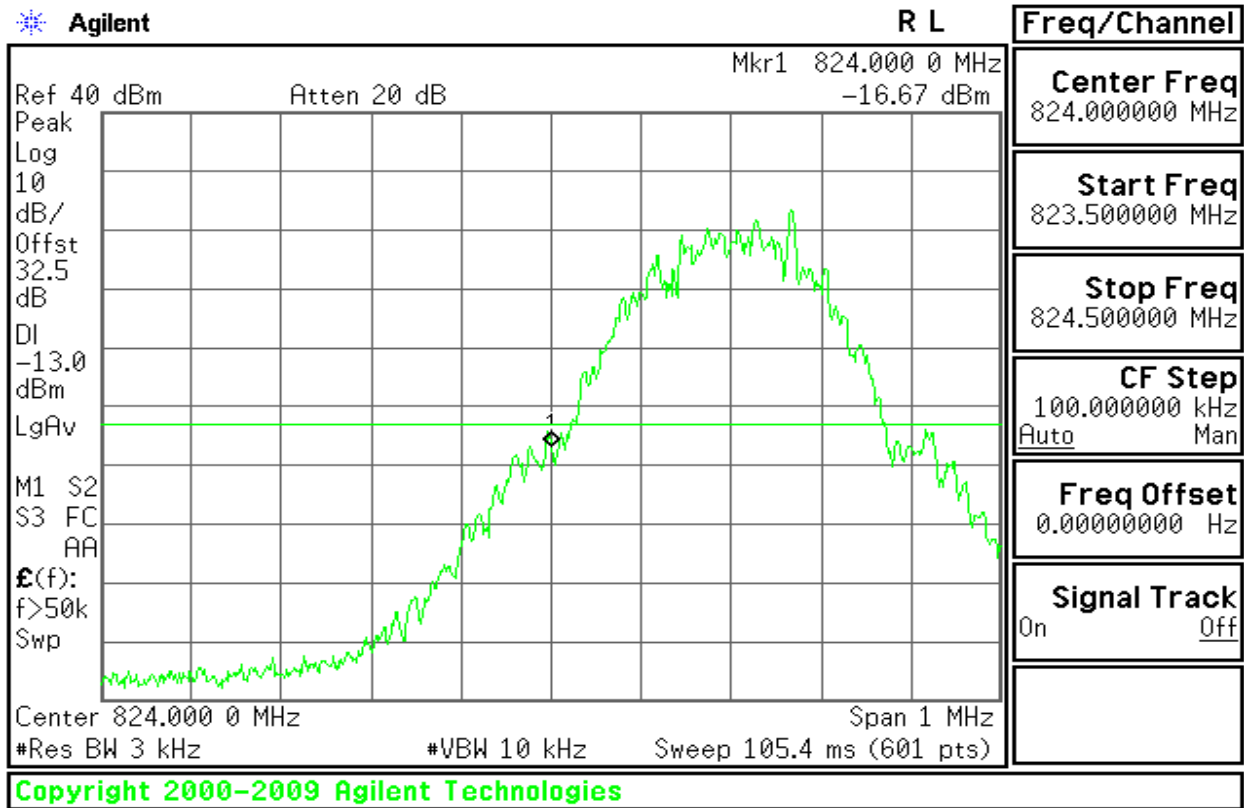
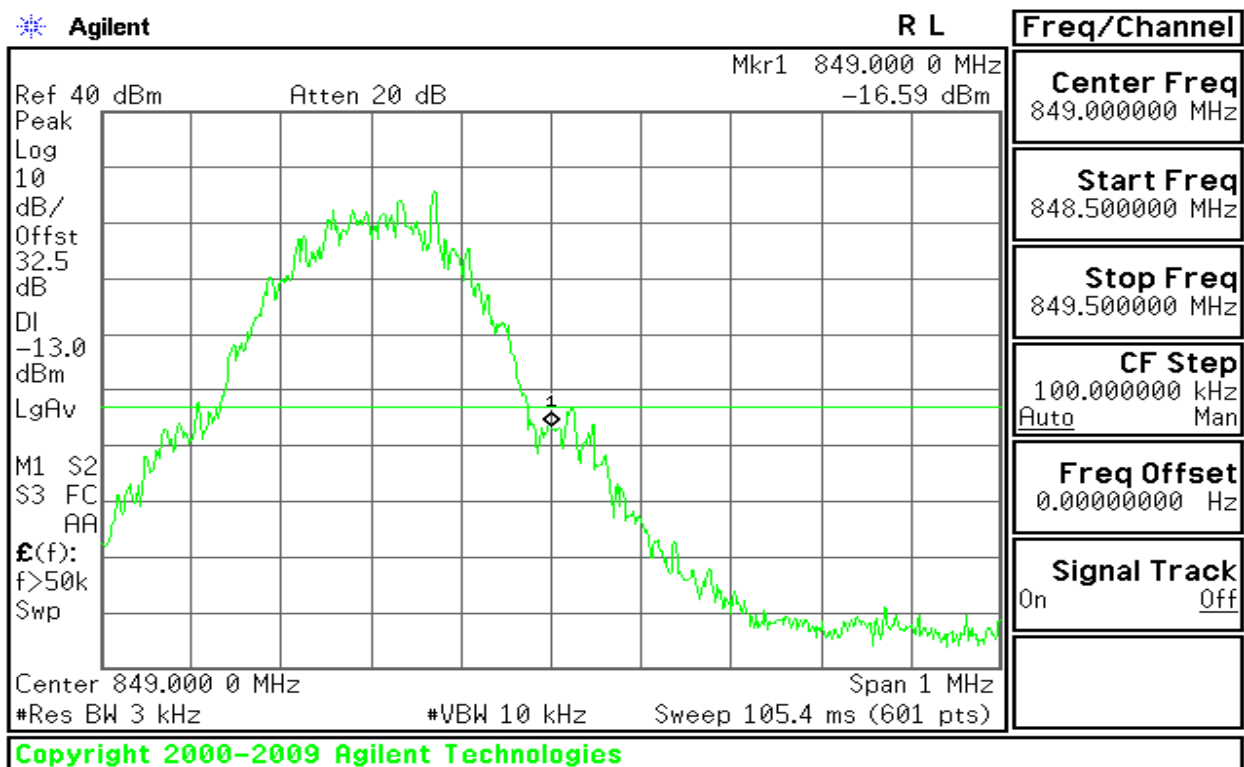

Figure 9-4: Band Edge emissions – GPRS CH High





GSM 1900

Figure 10-1: Band Edge emissions – GSM CH Low

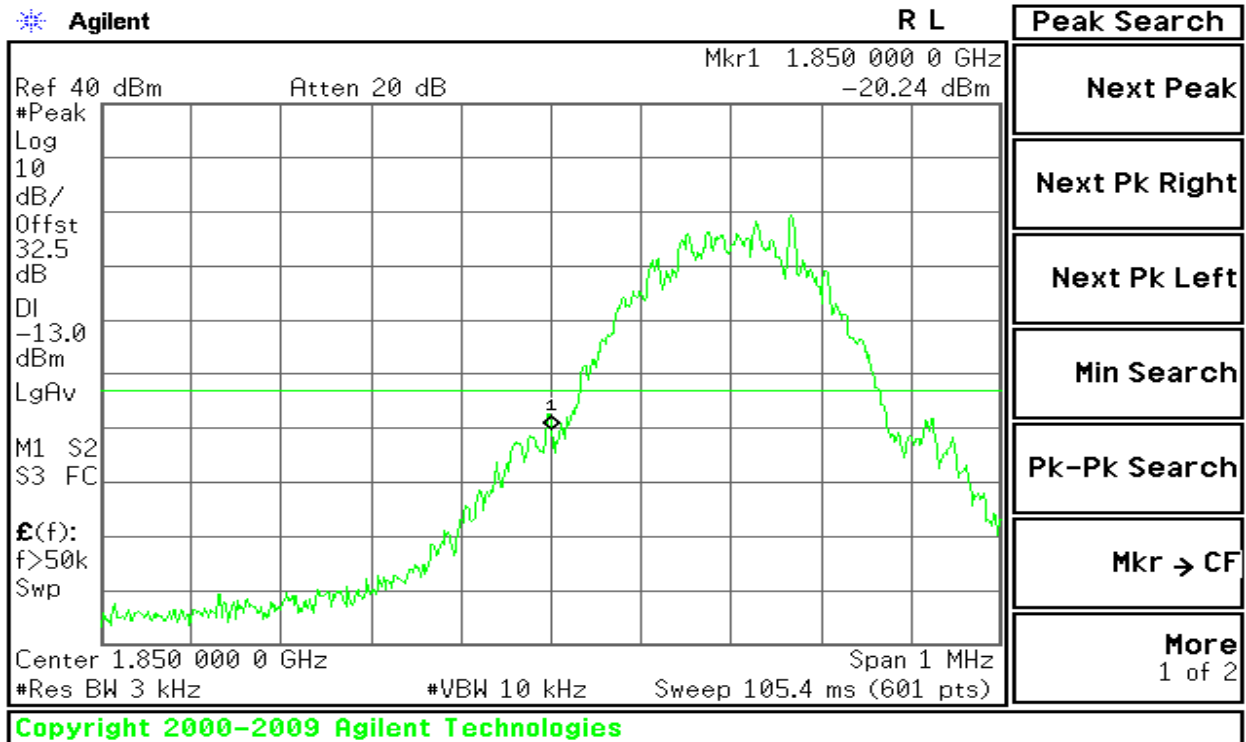
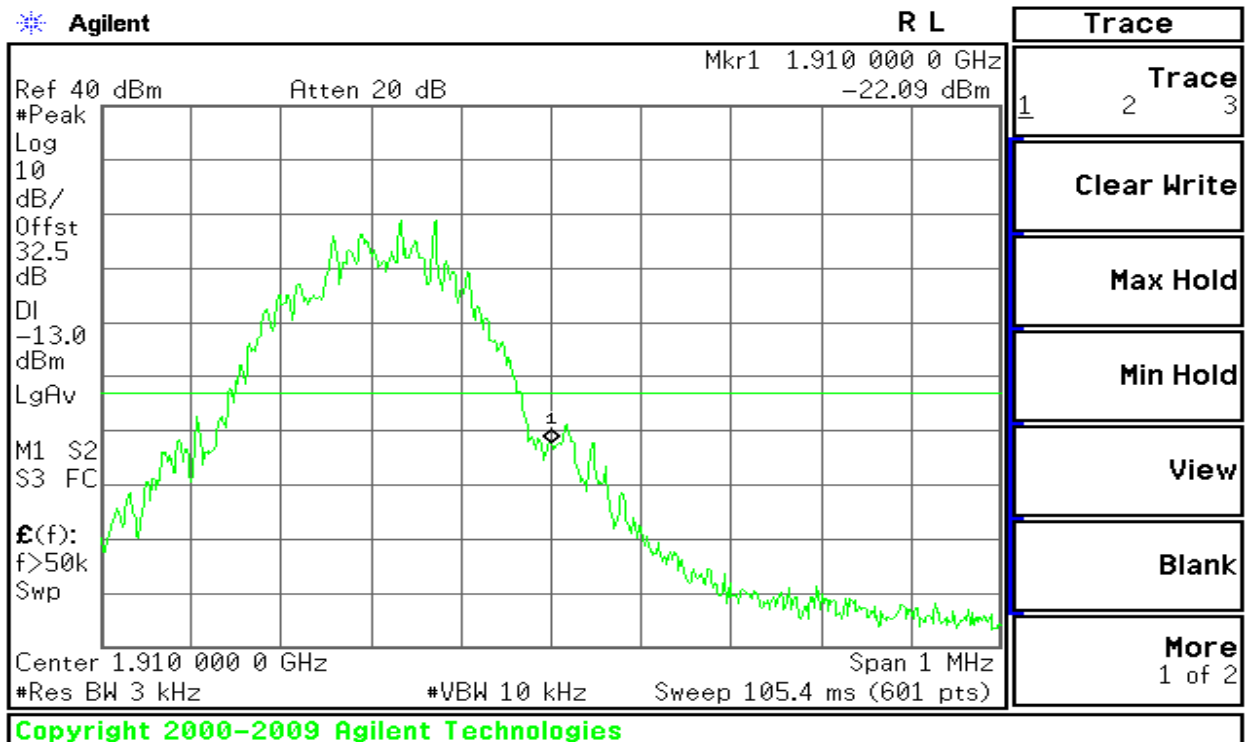

Figure 10-2: Band Edge emissions – GSM CH High



GPRS 1900

Figure 10-3: Band Edge emissions – GPRS CH Low

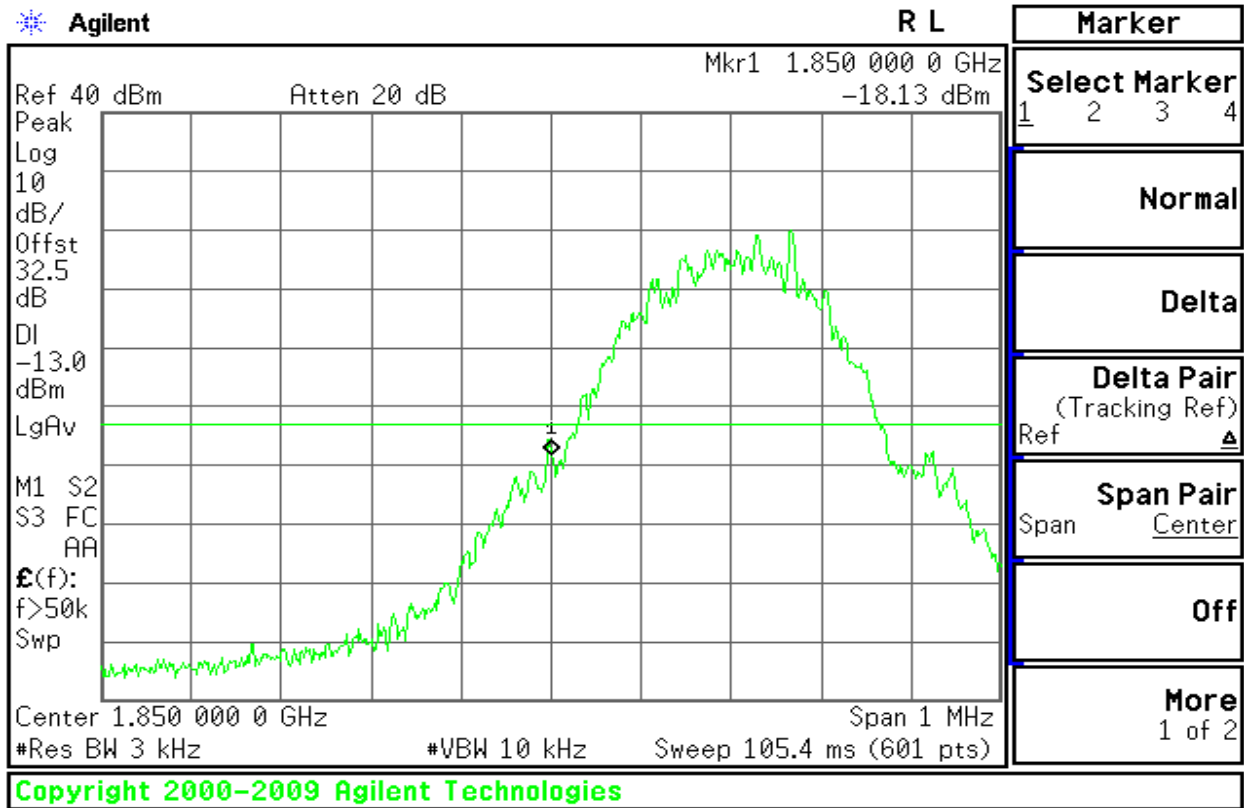
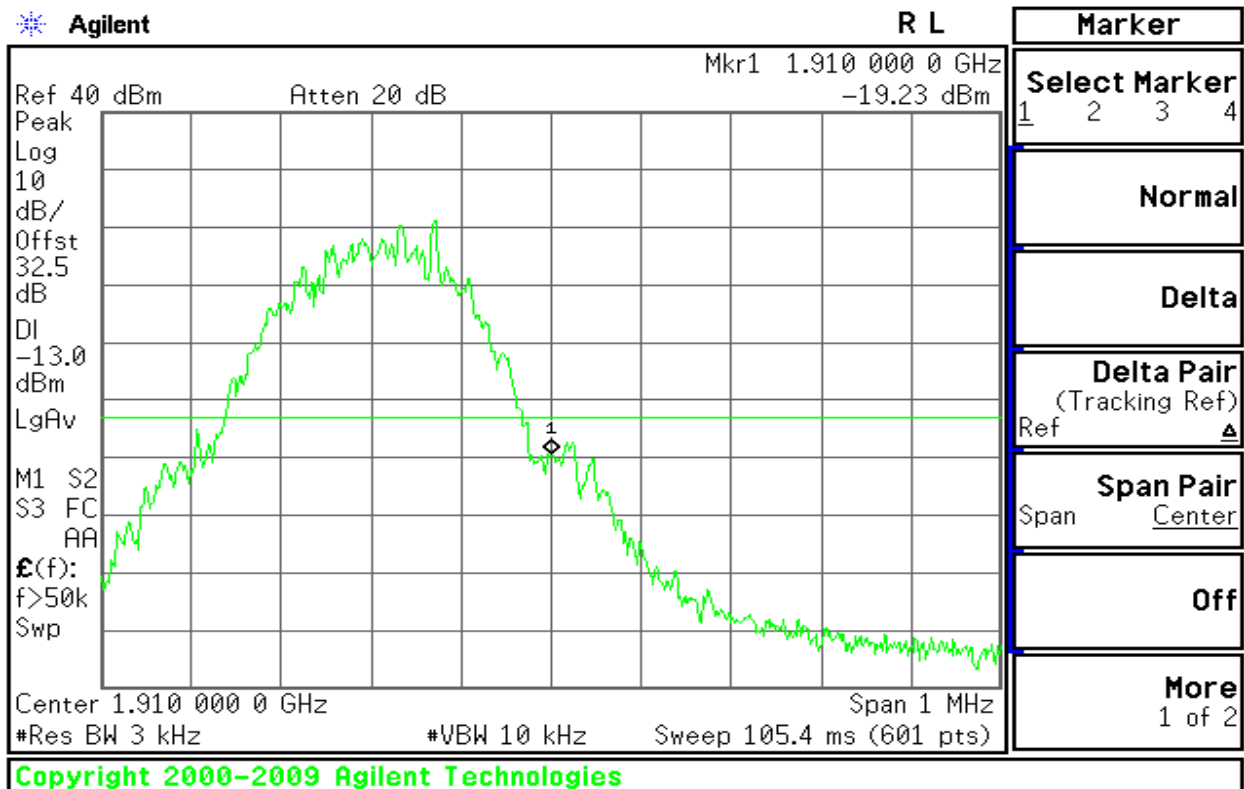

Figure 10-4: Band Edge emissions – GPRS CH High





FIELD STRENGTH OF SPURIOUS RADIATION MEASUREMENT

LIMIT

According to FCC §2.1053

MEASUREMENT EQUIPMENT USED

977 Chamber (3m)				
Name of Equipment	Manufacturer	Model	Serial Number	Calibration Due
Spectrum Analyzer	Agilent	E4446A	MY44020154	08/16/2009
EMI Test Receiver	R&S	ESPI3	101026	11/11/2009
Pre-Amplifier	MINI-circuits	ZFL-1000VH2	d041703	12/13/2009
Pre-Amplifier	Miteq	NSP4000-NF	870731	01/28/2010
Bilog Antenna	Sunol	JB1	A110204-2	11/22/2009
Horn-antenna	SCHWARZBECK	BBHA9120D	D:266	02/01/2010
PSG Analog Signal Generator	Agilent	E8257C	MY43321570	12/19/2009
Wireless communication test set	Agilent	8960	QB44051695	10/06/2009
Turn Table	CT	CT123	4165	N.C.R
Antenna Tower	CT	CTERG23	3256	N.C.R
Controller	CT	CT100	95637	N.C.R
Site NSA	CCS	N/A	N/A	04/06/2010

Remark: Each piece of equipment is scheduled for calibration once a year.

Test Configuration

Below 1 GHz

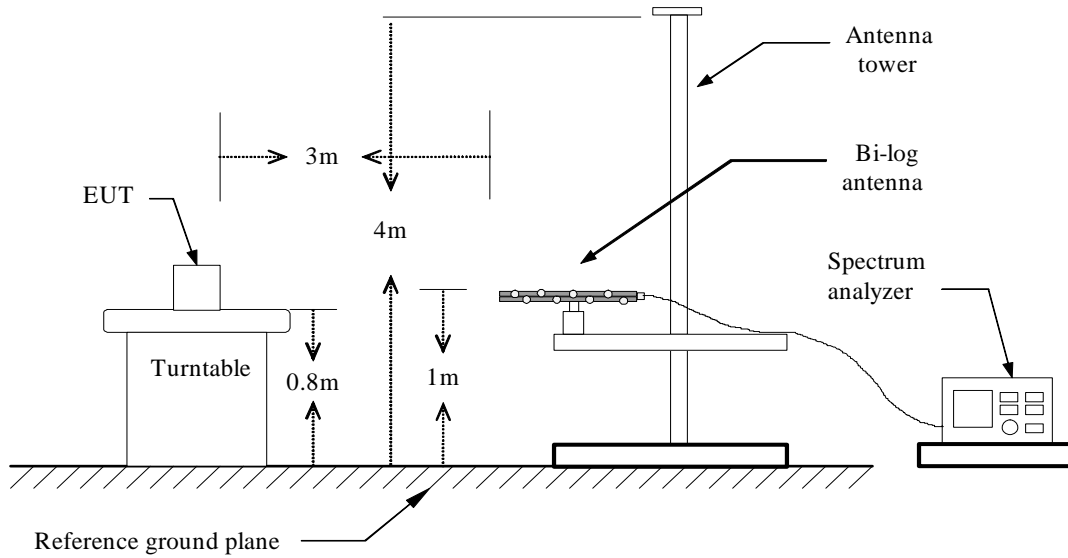

Above 1 GHz

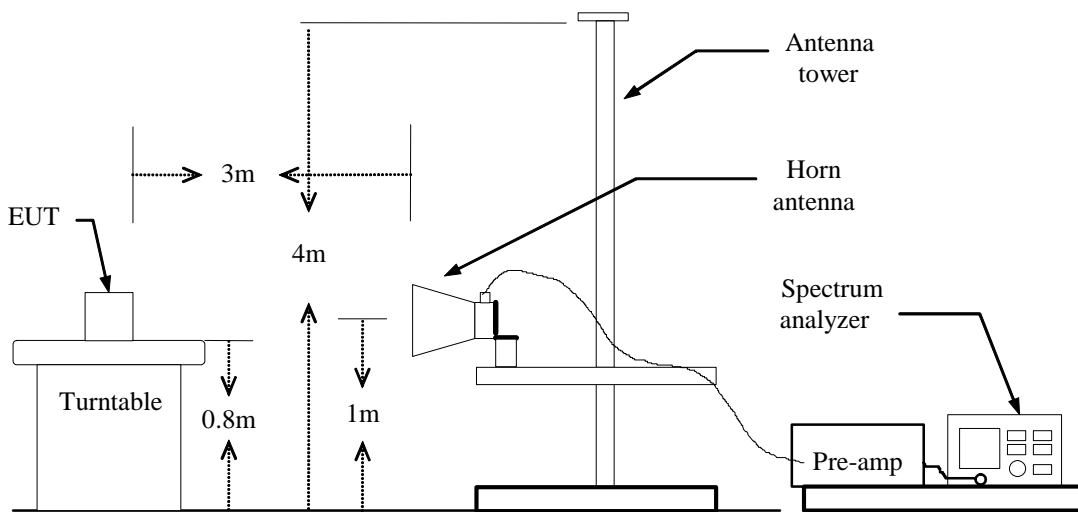

Substituted Method Test Set-up

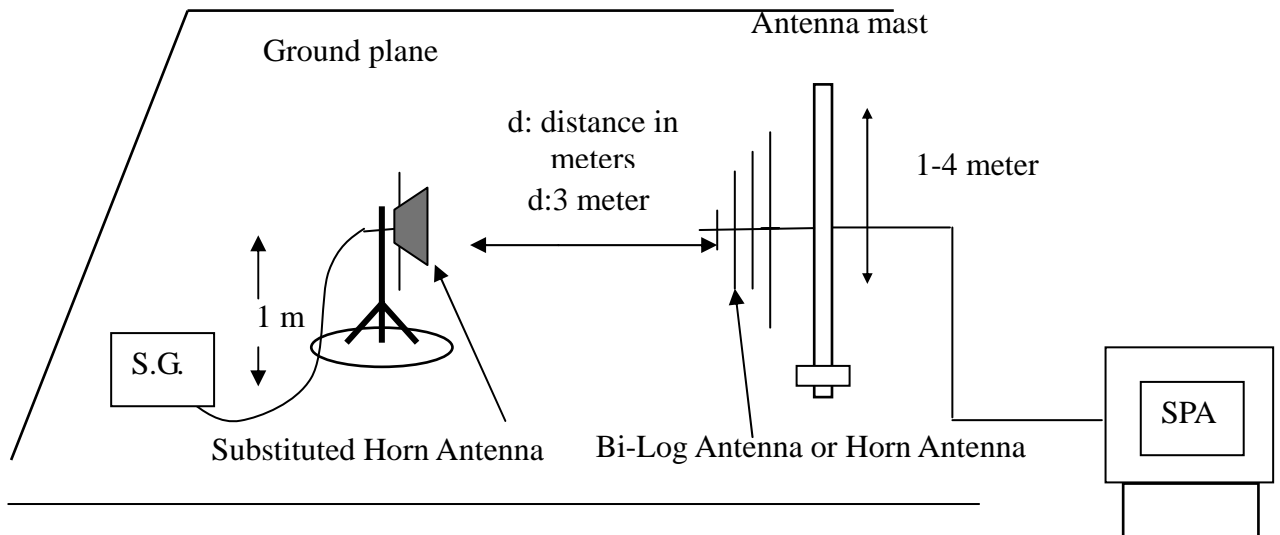



TEST PROCEDURE

The EUT was placed on a non-conductive, the measurement antenna was placed at a distance of 3 meters from the EUT. During the tests, the antenna height and the EUT azimuth were varied in order to identify the maximum level of emissions from the EUT. This maximization process was repeated with the EUT positioned in each of its three orthogonal orientations.

The frequency range up to tenth harmonic was investigated for each of three fundamental frequency (low, middle and high channels). Once spurious emission were identified, the power of the emission was determined using the substitution method.

The spurious emissions attenuation was calculated as the difference between radiated power at the fundamental frequency and the spurious emissions frequency.

ERP = S.G. output (dBm) + Antenna Gain (dBd) – Cable (dB)

EIRP = S.G. output (dBm) + Antenna Gain (dBi) – Cable (dB)

TEST RESULTS

Refer to the attached tabular data sheets.

**Radiated Spurious Emission Measurement Result****Below 1GHz**

No emissions to be recorded.

(No specific emission noted beyond the background noise floor)

Above 1GHz**Operation Mode:** GSM 850 / TX / CH 128**Test Date:** July 2, 2009**Temperature:** 25°C**Tested by:** Jeson**Humidity:** 55 % RH**Polarity:** Ver. / Hor.

Frequency (MHz)	Reading level (dBuV)	Antenna Polarization	S.G. (dBm)	Cable loss (dB)	Ant.Gain (dBd)	Emission level (dBm)	Limit (dBm)	Margin (dB)
1646.66	52.44	V	-52.17	2.94	9.76	-45.35	-13.00	-32.35
1650.00	47.02	H	-55.97	2.94	9.79	-49.12	-13.00	-36.12

Operation Mode: GSM 850 / TX / CH 190**Test Date:** July 2, 2009**Temperature:** 25°C**Tested by:** Jeson**Humidity:** 55 % RH**Polarity:** Ver. / Hor.

Frequency (MHz)	Reading level (dBuV)	Antenna Polarization	S.G. (dBm)	Cable loss (dB)	Ant.Gain (dBd)	Emission level (dBm)	Limit (dBm)	Margin (dB)
1673.33	52.41	V	-52.28	2.95	9.95	-45.28	-13.00	-32.28
1673.33	44.99	H	-62.01	2.95	9.95	-50.99	-13.00	-37.99

Operation Mode: GSM 850 / TX / CH 251**Test Date:** July 2, 2009**Temperature:** 25°C**Tested by:** Jeson**Humidity:** 55 % RH**Polarity:** Ver. / Hor.

Frequency (MHz)	Reading level (dBuV)	Antenna Polarization	S.G. (dBm)	Cable loss (dB)	Ant.Gain (dBd)	Emission level (dBm)	Limit (dBm)	Margin (dB)
1696.66	51.62	V	-53.13	2.97	10.11	-45.99	-13.00	-32.99
1696.66	44.88	H	-58.07	2.97	10.11	-50.93	-13.00	-37.93

Remark:

1. Measuring frequencies from 1 GHz to the 10th harmonic of highest fundamental frequency.
2. Measurements above shown only up to 6 maximum emissions noted, or would be lesser, with " N/A " remark, if no specific emissions from the EUT are recorded (ie: margin>20dB from the applicable limit) and considered that's already beyond the background noise floor.
3. Data of measurement within this frequency range shown " --- " in the table above means the reading of emissions are attenuated more than 20dB below the permissible limits or the field strength is too small to be measured.
4. Radiated emissions measured in frequency above 1000MHz were made with an instrument using Peak detector mode and average detector mode of the emission shown in Actual FS column.
5. Spectrum setting:
 - a. Peak Setting 1GHz to 10th harmonics of fundamental, RBW = 1MHz, VBW = 1MHz, Sweep time = Auto.
 - b. AV Setting 1GHz to 10th harmonics of fundamental, RBW = 1MHz, VBW = 10Hz, Sweep time = Auto.

**Operation Mode:** GPRS 850 / TX / CH 128**Test Date:** July 2, 2009**Temperature:** 25°C**Tested by:** Jeson**Humidity:** 55 % RH**Polarity:** Ver. / Hor.

Frequency (MHz)	Reading level (dBuV)	Antenna Polarization	S.G. (dBm)	Cable loss (dB)	Ant.Gain (dBd)	Emission level (dBm)	Limit (dBm)	Margin (dB)
1646.32	51.14	V	-53.47	2.94	9.76	-46.65	-13.00	-33.65
1648.12	45.72	H	-57.27	2.94	9.79	-50.42	-13.00	-37.42

Operation Mode: GPRS 850 / TX / CH 190**Test Date:** July 2, 2009**Temperature:** 25°C**Tested by:** Jeson**Humidity:** 55 % RH**Polarity:** Ver. / Hor.

Frequency (MHz)	Reading level (dBuV)	Antenna Polarization	S.G. (dBm)	Cable loss (dB)	Ant.Gain (dBd)	Emission level (dBm)	Limit (dBm)	Margin (dB)
1674.56	51.31	V	-53.38	2.95	9.95	-46.38	-13.00	-33.38
1674.55	43.89	H	-59.09	2.95	9.95	-52.09	-13.00	-39.09

Operation Mode: GPRS 850 / TX / CH 251**Test Date:** July 2, 2009**Temperature:** 25°C**Tested by:** Jeson**Humidity:** 55 % RH**Polarity:** Ver. / Hor.

Frequency (MHz)	Reading level (dBuV)	Antenna Polarization	S.G. (dBm)	Cable loss (dB)	Ant.Gain (dBd)	Emission level (dBm)	Limit (dBm)	Margin (dB)
1695.23	50.82	V	-53.93	2.97	10.11	-46.79	-13.00	-33.79
1695.23	45.68	H	-58.87	2.97	10.11	-51.73	-13.00	-38.73

Remark:

1. Measuring frequencies from 1 GHz to the 10th harmonic of highest fundamental frequency.
2. Measurements above shown only up to 6 maximum emissions noted, or would be lesser, with " N/A " remark, if no specific emissions from the EUT are recorded (ie: margin>20dB from the applicable limit) and considered that's already beyond the background noise floor.
3. Data of measurement within this frequency range shown " --- " in the table above means the reading of emissions are attenuated more than 20dB below the permissible limits or the field strength is too small to be measured.
4. Radiated emissions measured in frequency above 1000MHz were made with an instrument using Peak detector mode and average detector mode of the emission shown in Actual FS column.
5. Spectrum setting:
 - a. Peak Setting 1GHz to 10th harmonics of fundamental, RBW = 1MHz, VBW = 1MHz, Sweep time = Auto.
 - b. AV Setting 1GHz to 10th harmonics of fundamental, RBW = 1MHz, VBW = 10Hz, Sweep time = Auto.

**Below 1GHz***No emissions to be recorded.**(No specific emission noted beyond the background noise floor)***Above 1GHz****Operation Mode:** GSM 1900 / TX / CH 512**Test Date:** July 2, 2009**Temperature:** 25°C**Tested by:** Jeson**Humidity:** 55 % RH**Polarity:** Ver. / Hor.

Frequency (MHz)	Reading level (dBuV)	Antenna Polarization	S.G. (dBm)	Cable loss (dB)	Ant.Gain (dBi)	Emission level (dBm)	Limit (dBm)	Margin (dB)
3700.00	40.74	V	-55.31	4.52	12.66	-47.17	-13.00	-34.17
3691.66	35.74	H	-60.17	4.51	12.65	-52.00	-13.00	-39.00

Operation Mode: GSM 1900 / TX / CH 661**Test Date:** July 2, 2009**Temperature:** 25°C**Tested by:** Jeson**Humidity:** 55 % RH**Polarity:** Ver. / Hor.

Frequency (MHz)	Reading level (dBuV)	Antenna Polarization	S.G. (dBm)	Cable loss (dB)	Ant.Gain (dBi)	Emission level (dBm)	Limit (dBm)	Margin (dB)
3758.33	43.34	V	-52.35	4.54	12.71	-44.17	-13.00	-31.17
3758.33	37.18	H	-58.25	4.54	12.71	-50.07	-13.00	-37.07

Operation Mode: GSM 1900 / TX / CH 810**Test Date:** July 2, 2009**Temperature:** 25°C**Tested by:** Jeson**Humidity:** 55 % RH**Polarity:** Ver. / Hor.

Frequency (MHz)	Reading level (dBuV)	Antenna Polarization	S.G. (dBm)	Cable loss (dB)	Ant.Gain (dBi)	Emission level (dBm)	Limit (dBm)	Margin (dB)
3816.66	41.14	V	-54.26	4.60	12.74	-46.12	-13.00	-33.12
3908.33	37.53	H	-57.07	4.87	12.67	-49.27	-13.00	-36.27

Remark:

1. Measuring frequencies from 1 GHz to the 10th harmonic of highest fundamental frequency.
2. Measurements above shown only up to 6 maximum emissions noted, or would be lesser, with " N/A " remark, if no specific emissions from the EUT are recorded (ie: margin>20dB from the applicable limit) and considered that's already beyond the background noise floor.
3. Data of measurement within this frequency range shown " --- " in the table above means the reading of emissions are attenuated more than 20dB below the permissible limits or the field strength is too small to be measured.
4. Radiated emissions measured in frequency above 1000MHz were made with an instrument using Peak detector mode and average detector mode of the emission shown in Actual FS column.
5. Spectrum setting:
 - a. Peak Setting 1GHz to 10th harmonics of fundamental, RBW = 1MHz, VBW = 1MHz, Sweep time = Auto.
 - b. AV Setting 1GHz to 10th harmonics of fundamental, RBW = 1MHz, VBW = 10Hz, Sweep time = Auto.



Operation Mode: GPRS 1900 / TX / CH 512

Test Date: July 2, 2009

Temperature: 25°C

Tested by: Jeson

Humidity: 55 % RH

Polarity: Ver. / Hor.

Frequency (MHz)	Reading level (dBuV)	Antenna Polarization	S.G. (dBm)	Cable loss (dB)	Ant.Gain (dBd)	Emission level (dBm)	Limit (dBm)	Margin (dB)
3712.56	39.54	V	-56.51	4.52	12.66	-48.37	-13.00	-35.37
3712.21	34.54	H	-61.33	4.51	12.65	-53.20	-13.00	-40.02

Operation Mode: GPRS 1900 / TX / CH 661

Test Date: July 2, 2009

Temperature: 25°C

Tested by: Jeson

Humidity: 55 % RH

Polarity: Ver. / Hor.

Frequency (MHz)	Reading level (dBuV)	Antenna Polarization	S.G. (dBm)	Cable loss (dB)	Ant.Gain (dBd)	Emission level (dBm)	Limit (dBm)	Margin (dB)
3761.66	42.14	V	-53.54	4.54	12.71	-45.37	-13.00	-32.37
3761.65	35.98	H	-59.44	4.54	12.71	-51.27	-13.00	-38.27

Operation Mode: GPRS 1900 / TX / CH 810

Test Date: July 2, 2009

Temperature: 25°C

Tested by: Jeson

Humidity: 55 % RH

Polarity: Ver. / Hor.

Frequency (MHz)	Reading level (dBuV)	Antenna Polarization	S.G. (dBm)	Cable loss (dB)	Ant.Gain (dBd)	Emission level (dBm)	Limit (dBm)	Margin (dB)
3819.32	38.94	V	-55.46	4.60	12.74	-47.32	-13.00	-34.32
3817.35	36.33	H	-58.27	4.87	12.67	-50.47	-13.00	-37.47

Remark:

1. Measuring frequencies from 1 GHz to the 10th harmonic of highest fundamental frequency.
2. Measurements above shown only up to 6 maximum emissions noted, or would be lesser, with " N/A " remark, if no specific emissions from the EUT are recorded (ie: margin>20dB from the applicable limit) and considered that's already beyond the background noise floor.
3. Data of measurement within this frequency range shown " --- " in the table above means the reading of emissions are attenuated more than 20dB below the permissible limits or the field strength is too small to be measured.
4. Radiated emissions measured in frequency above 1000MHz were made with an instrument using Peak detector mode and average detector mode of the emission shown in Actual FS column.
5. Spectrum setting:
 - a. Peak Setting 1GHz to 10th harmonics of fundamental, RBW = 1MHz, VBW = 1MHz, Sweep time = Auto.
 - b. AV Setting 1GHz to 10th harmonics of fundamental, RBW = 1MHz, VBW = 10Hz, Sweep time = Auto.

FREQUENCY STABILITY V.S. TEMPERATURE MEASUREMENT

LIMIT

According to FCC §2.1055, FCC §24.235.

Frequency Tolerance: 2.5 ppm

MEASUREMENT EQUIPMENT USED

Name of Equipment	Manufacturer	Model	Serial Number	Calibration Due
DC POWER SUPPLY	GW instek	GPS-3303C	E903131	04/15/2010
Spectrum Analyzer	Agilent	E4446A	MY44020154	08/16/2009
Wireless communication test set	Agilent	8960	QB44051695	10/06/2009
Temp. / Humidity Chamber	Kingson	THS-M1	242	05/26/2010

Remark: Each piece of equipment is scheduled for calibration once a year.

Test Configuration

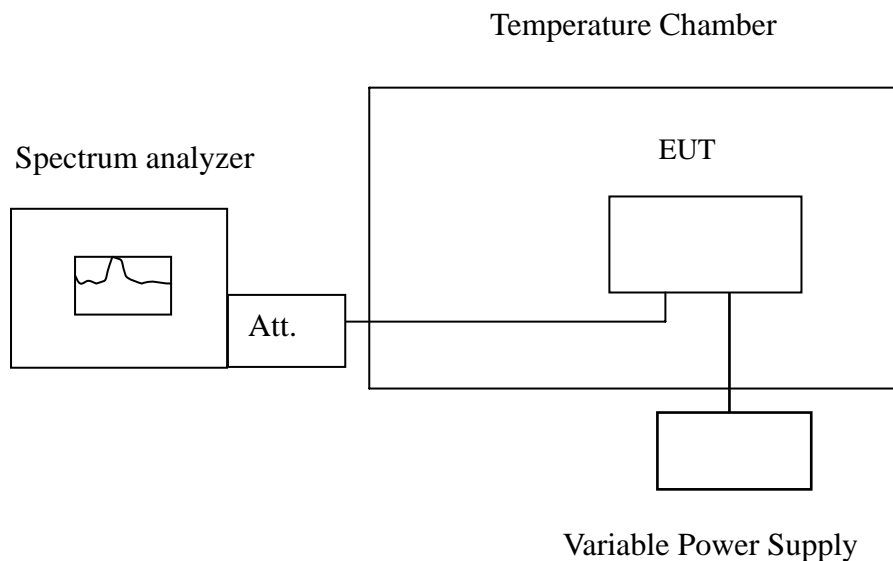

Remark: Measurement setup for testing on Antenna connector



TEST PROCEDURE

The equipment under test was connected to an external AC or DC power supply and input rated voltage. RF output was connected to a frequency counter or spectrum analyzer via feed through attenuators. The EUT was placed inside the temperature chamber. Set the spectrum analyzer RBW low enough to obtain the desired frequency resolution and measure EUT 20°C operating frequency as reference frequency. Turn EUT off and set the chamber temperature to -30°C. After the temperature stabilized for approximately 30 minutes recorded the frequency. Repeat step measure with 10°C increased per stage until the highest temperature of +50°C reached.

TEST RESULTS

No non-compliance noted.

Reference Frequency: GSM Mid Channel 836.6 MHz @ 20°C				
Limit: ± 2.5 ppm = 2091.5 Hz				
Power Supply Vdc	Environment Temperature (°C)	Frequency (Hz)	Delta (Hz)	Limit (Hz)
3.8	55	836600027	27	2091.5
	40	836600031	31	
	30	836600023	23	
	20	836599985	-15	
	10	836600026	26	
	0	836600027	27	
	-10	836600036	36	
	-20	836600038	38	

Reference Frequency: GSM Mid Channel 1880 MHz @ 20°C				
Limit: ± 2.5 ppm = 4700 Hz				
Power Supply Vdc	Environment Temperature (°C)	Frequency (Hz)	Delta (Hz)	Limit (Hz)
3.8	55	1879999983	-17	4700
	40	1879999983	-17	
	30	1879999979	-21	
	20	1880000015	15	
	10	1879999991	-9	
	0	1879999977	-23	
	-10	1879999982	-18	
	-20	1879999986	-14	

FREQUENCY STABILITY V.S. VOLTAGE MEASUREMENT

LIMIT

According to FCC §2.1055, FCC §24.235,

Frequency Tolerance: 2.5 ppm.

MEASUREMENT EQUIPMENT USED

Name of Equipment	Manufacturer	Model	Serial Number	Calibration Due
DC POWER SUPPLY	GW instek	GPS-3303C	E903131	04/15/2010
Spectrum Analyzer	Agilent	E4446A	MY44020154	08/16/2009
Wireless communication test set	Agilent	8960	QB44051695	10/06/2009
Temp. / Humidity Chamber	Kingson	THS-M1	242	05/26/2010

Remark: Each piece of equipment is scheduled for calibration once a year.

Test Configuration

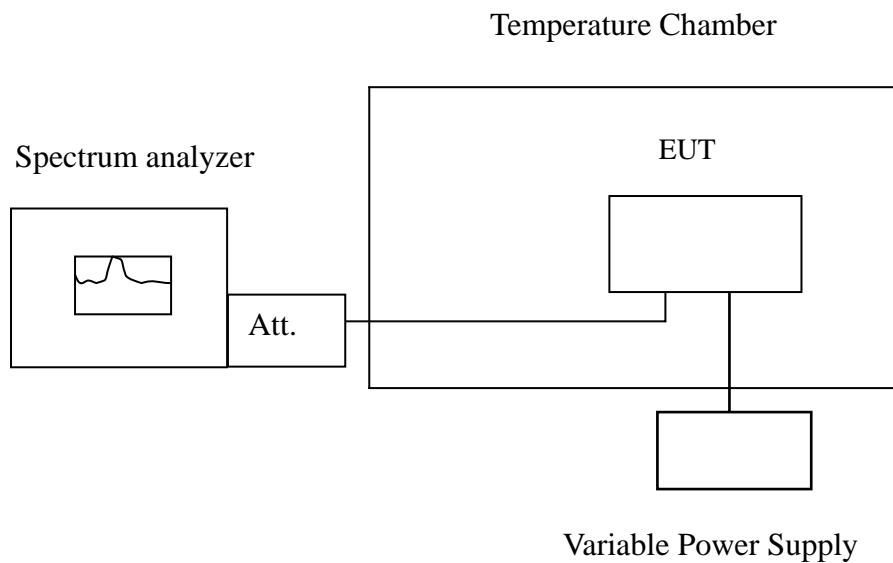

Remark: Measurement setup for testing on Antenna connector.



TEST PROCEDURE

Set chamber temperature to 20°C. Use a variable AC power supply / DC power source to power the EUT and set the voltage to rated voltage. Set the spectrum analyzer RBW low enough to obtain the desired frequency resolution and recorded the frequency.

Reduce the input voltage to specify extreme voltage variation (± 15%) and endpoint, record the maximum frequency change.

TEST RESULTS

No non-compliance noted.

Reference Frequency: GSM Mid Channel 836.6 MHz @ 20°C				
Limit: ± 2.5 ppm = 2091.5Hz				
Power Supply Vdc	Environment Temperature (°C)	Frequency (Hz)	Delta (Hz)	Limit (Hz)
4.2	20	836599981	-19	2091.5
3.8		836599985	-15	
3.5		836599985	-15	
3.3 End point		836599959	-41	

Reference Frequency: GSM Mid Channel 1880 MHz @ 20°C				
Limit: ± 2.5 ppm = 4700 Hz				
Power Supply Vdc	Environment Temperature (°C)	Frequency (Hz)	Delta (Hz)	Limit (Hz)
4.2	20	1880000019	19	4700
3.8		1880000015	15	
3.5		1880000015	15	
3.3 End point		1880000013	13	



POWERLINE CONDUCTED EMISSIONS

LIMIT

For an intentional radiator which is designed to be connected to the public utility (AC) power line, the radio frequency voltage that is conducted back onto the AC power line on any frequency or frequencies within the band 150 kHz to 30 MHz shall not exceed 250 microvolts (The limit decreases linearly with the logarithm of the frequency in the range 0.15 MHz to 0.50 MHz). The limits at specific frequency range is listed as follows:

Frequency Range (MHz)	Limits (dBμV)	
	Quasi-peak	Average
0.15 to 0.50	66 to 56	56 to 46
0.50 to 5	56	46
5 to 30	60	50

Compliance with this provision shall be based on the measurement of the radio frequency voltage between each power line (LINE and NEUTRAL) and ground at the power terminals.

MEASUREMENT EQUIPMENT USED

Name of Equipment	Manufacturer	Model	Serial Number	Calibration Due
EMI Test Receiver	R&S	ESI26	100068	02/11/2010
EMC Analyzer	Agilent	E7402A	US41160329	02/11/2010
LISN	FCC	FCC-LISN-50-50-2-M	01067	07/29/2009
LISN (EUT)	FCC	FCC-LISN-50-50-2-M	01068	07/29/2009
TRANSIENT LIMITER	SCHAFFNER	CFL9206	1710	03/15/2010
EMI Monitor control box	FCC	0-SVDC	N/A	N.C.R

Remark: Each piece of equipment is scheduled for calibration once a year.

Test Configuration

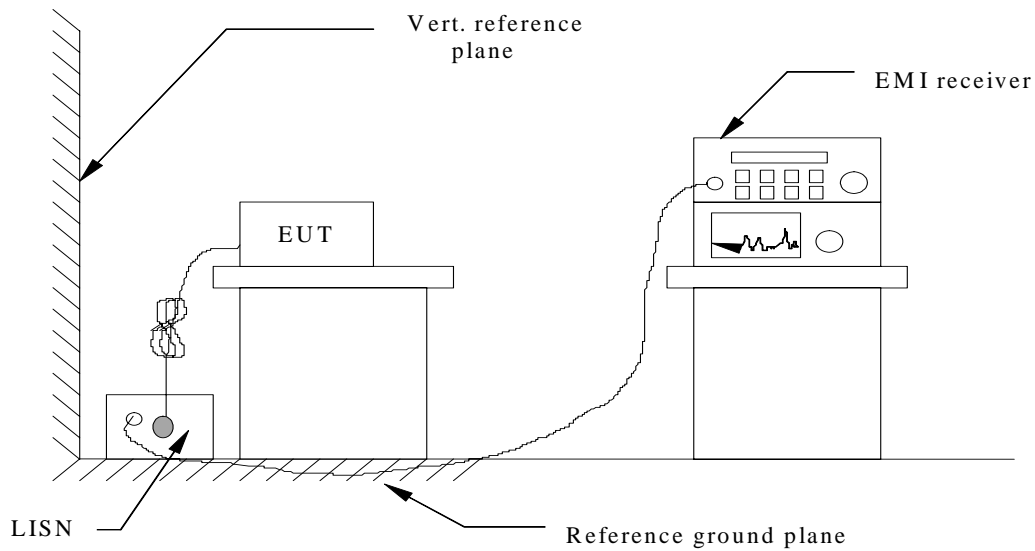

See test photographs attached in Appendix 1 for the actual connections between EUT and support equipment.

TEST PROCEDURE

1. The EUT was placed on a table, which is 0.8m above ground plane.
2. Maximum procedure was performed on the six highest emissions to ensure EUT compliance.
3. Repeat above procedures until all frequency measured were complete..



TEST RESULTS

The initial step in collecting conducted data is a spectrum analyzer peak scan of the measurement range. Significant peaks are then marked as shown on the following data page, and these signals are then quasi-peaked.

Operation Mode: Link mode
 AC TO DC CHARGER **Test Date:** July 1, 2009
Temperature: 25°C **Tested by:** Jeson
Humidity: 55% RH

Freq. (MHz)	PEAK Raw (dBuV)	Q.P. Raw (dBuV)	AVG Raw (dBuV)	Q.P. Limit (dBuV)	AVG Limit (dBuV)	Margin (dB)	Factor (dB)	Remark
0.487	29.56	20.82	15.01	56.36	46.36	-31.35	10.77	L1
0.631	32.15	21.41	16.11	56.00	46.00	-29.89	10.89	L1
1.184	30.94	20.48	13.48	56.00	46.00	-32.52	11.03	L1
4.557	34.62	25.78	21.27	56.00	46.00	-24.73	11.18	L1
7.090	35.24	26.32	21.32	60.00	50.00	-28.68	11.19	L1
12.188	35.37	26.17	18.35	60.00	50.00	-31.65	11.25	L1
0.639	30.46	25.02	21.51	56.00	46.00	-24.49	10.14	L2
1.158	26.83	25.66	18.68	56.00	46.00	-27.32	10.27	L2
3.498	27.32	22.76	21.99	56.00	46.00	-24.01	10.80	L2
6.400	30.65	18.70	15.13	60.00	50.00	-34.87	11.01	L2
12.220	30.47	18.90	16.11	60.00	50.00	-33.89	11.30	L2
15.971	31.26	20.15	14.68	60.00	50.00	-35.32	11.46	L2

Remark:

- The measuring frequencies range between 0.15 MHz and 30 MHz.
- The emissions measured in the frequency range between 0.15 MHz and 30MHz were made with an instrument using Quasi-peak detector and Average detector.
- “--” denotes the emission level was or more than 2dB below the Average limit, and no re-check was made.
- The IF bandwidth of SPA between 0.15MHz and 30MHz was 10KHz. The IF bandwidth of Test Receiver between 0.15MHz and 30MHz was 9kHz
- L1 = Line One (Live Line) / L2 = Line Two (Neutral Line)

Note:

Freq. = Emission frequency in KHz

Factor (dB) = cable loss + Insertion loss of LISN+ Insertion loss of TRANSIENT LIMITER (The TRANSIENT LIMITER included 10 dB ATTENUATION)

Amptd dBuV = Uncorrected Analyzer/Receiver reading + cable loss + Insertion loss of LISN+ Insertion loss of TRANSIENT LIMITER, if it > 0.5 dB

Limit dBuV = Limit stated in standard

Margin dB = Reading in reference to limit

Calculation Formula

Margin (dB) = Amptd (dBuV) – Limit (dBuV)



Test Plots

AC TO DC CHARGER

Conducted emissions (Line 1)

Index:

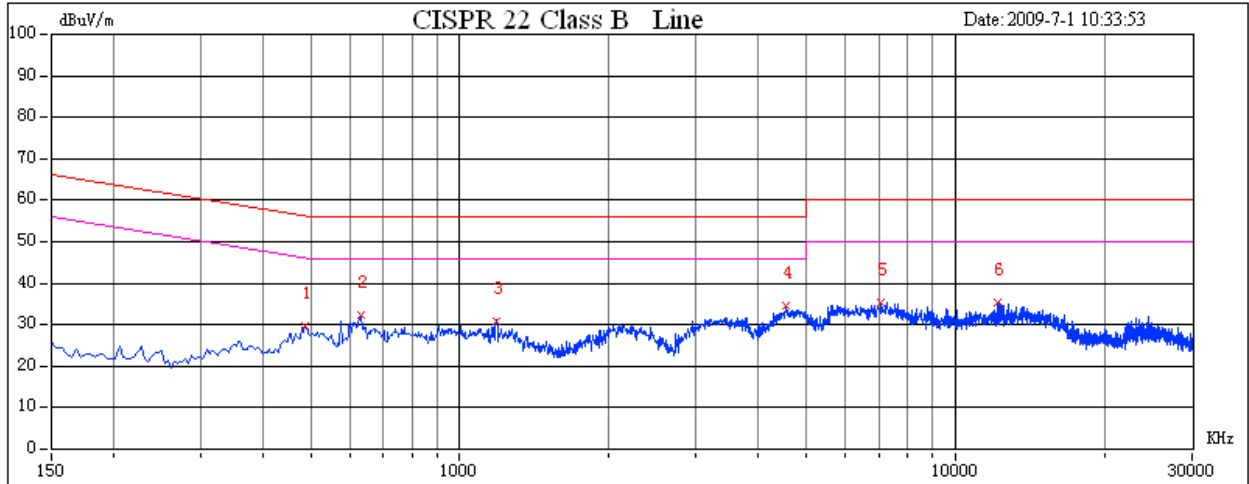

Conducted emissions (Line 2)

Index:

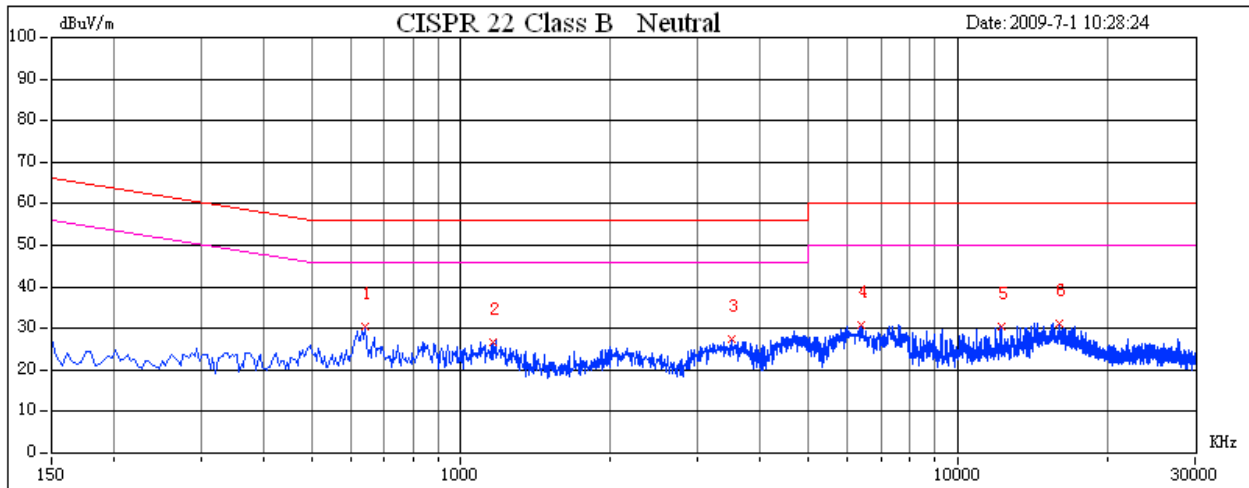

APPENDIX 1 PHOTOGRAPHS OF TEST SETUP

Radiated Emission Set up Photos

Front of view

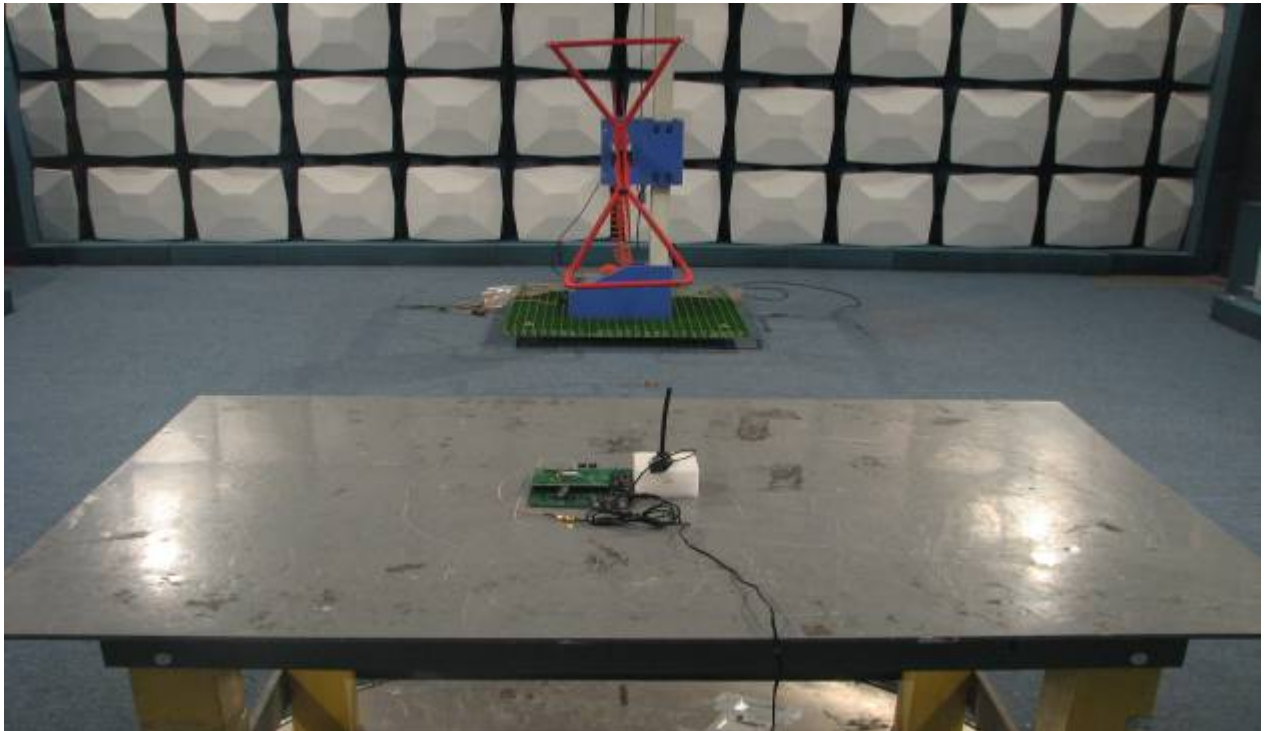

Back of view

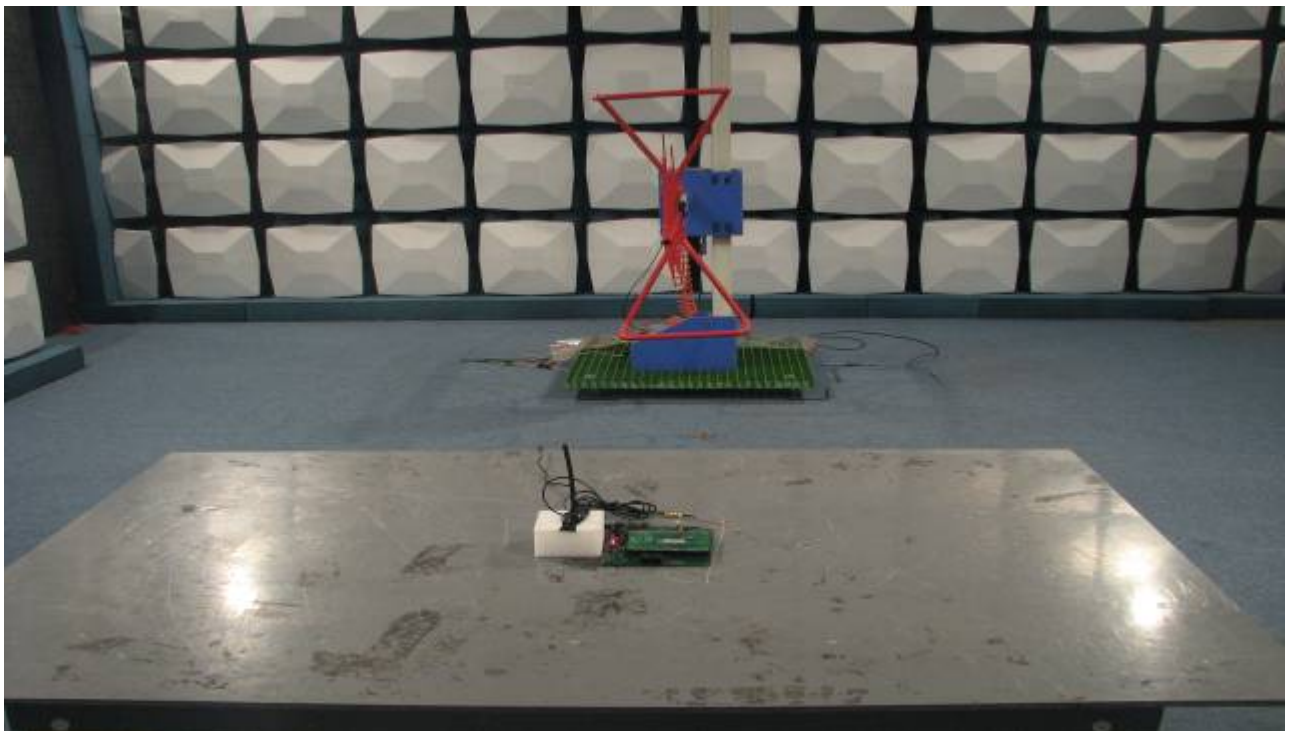

Conducted Emission Set Up Photos

