

FCC 47 CFR PART 15 SUBPART C

Applicant : Mobile Action Technology Inc.
Product Type : Bluetooth 4.0 Low Energy Wristband
Trade Name : Q-Watch
Model Number : Q-77
Test Specification : FCC 47 CFR PART 15 SUBPART C
ANSI C63.10:2013
Receive Date : Apr. 13, 2016
Test Period : Apr. 14 ~ Apr. 20, 2016
Issue Date : Apr. 27, 2016

Issue by

A Test Lab Techno Corp.
No. 140-1, Changan Street, Bade District,
Taoyuan City 33465, Taiwan (R.O.C)
Tel : +886-3-2710188 / Fax : +886-3-2710190



Taiwan Accreditation Eoundation accreditation number: 1330

Note: This report shall not be reproduced except in full, without the written approval of A Test Lab Techno Corp. This document may be altered or revised by A Test Lab Techno Corp. personnel only, and shall be noted in the revision section of the document. The client should not use it to claim product endorsement by TAF, or any government agencies. The test results in the report only apply to the tested sample.



Revision History

Rev.	Issue Date	Revisions	Revised By
00	Apr. 27, 2016	Initial Issue	Snow Wang

Verification of Compliance

Issued Date: Apr. 27, 2016

Applicant : Mobile Action Technology Inc.
Product Type : Bluetooth 4.0 Low Energy Wristband
Trade Name : Q-Watch
Model Number : Q-77
FCC ID : Q7Z-16077R1
EUT Rated Voltage : DC 5V, 0.1A
Test Voltage : 120 Vac / 60 Hz
Applicable Standard : FCC 47 CFR PART 15 SUBPART C
ANSI C63.10:2013
Test Result : Complied
Performing Lab. : A Test Lab Techno Corp.
No. 140-1, Changan Street, Bade District,
Taoyuan City 33465, Taiwan (R.O.C)
Tel : +886-3-2710188 / Fax : +886-3-2710190
Taiwan Accreditation Foundation accreditation number: 1330
<http://www.atl-lab.com.tw/e-index.htm>



A Test Lab Techno Corp. tested the above equipment in accordance with the requirements set forth in the above standards. All indications of Pass/Fail in this report are opinions expressed by A Test Lab Techno Corp. based on interpretations and/or observations of test results. Measurement Uncertainties were not taken into account and are published for informational purposes only. The test results show that the equipment tested is capable of demonstrating compliance with the requirements as documented in this report.

Approved By : Fly Lu Reviewed By : Eric Ou Yang
(Manager) (Fly Lu) (Testing Engineer) (Eric Ou Yang)



TABLE OF CONTENTS

1	General Information	6
2	EUT Description	7
3	Test Methodology	8
3.1.	Mode of Operation	8
3.2.	EUT Exercise Software	8
3.3.	Configuration of Test System Details	9
3.4.	Test Site Environment	9
4	Conducted Emission Measurement	10
4.1.	Limit	10
4.2.	Test Instruments	10
4.3.	Test Setup	10
4.4.	Test Procedure	11
4.5.	Test Result	12
5	Radiated Emission Measurement	14
5.1.	Limit	14
5.2.	Test Instruments	14
5.3.	Setup	15
5.4.	Test Procedure	16
5.5.	Test Result	18
6	Maximum Conducted Output Power Measurement	22
6.1.	Limit	22
6.2.	Test Setup	22
6.3.	Test Instruments	22
6.4.	Test Procedure	22
6.5.	Test Result	22
7	6dB RF Bandwidth Measurement	23
7.1.	Limit	23
7.2.	Test Setup	23
7.3.	Test Instruments	23
7.4.	Test Procedure	23
7.5.	Test Result	24
7.6.	Test Graphs	25



8	Maximum Power Density Measurement.....	26
8.1.	Limit.....	26
8.2.	Test Setup	26
8.3.	Test Instruments	26
8.4.	Test Procedure	26
8.5.	Test Result	27
8.6.	Test Graphs	28
9	Out of Band Conducted Emissions Measurement.....	29
9.1.	Limit.....	29
9.2.	Test Setup	29
9.3.	Test Instruments	29
9.4.	Test Procedure	29
9.5.	Test Graphs	30
10	Antenna Measurement.....	33
10.1.	Limit.....	33
10.2.	Antenna Connector Construction	33



1 General Information

1.1 Summary of Test Result

Standard	Item	Result	Remark
15.207	AC Power Conducted Emission	PASS	-----
15.247(d)	Transmitter Radiated Emissions	PASS	-----
15.247(b)(3)	Max. Output Power	PASS	-----
15.247(a)(2)	6dB RF Bandwidth	PASS	-----
15.247(e)	Power Spectral Density	PASS	-----
15.247(d)	Out of Band Conducted Spurious Emission	PASS	-----
15.203	Antenna Requirement	PASS	-----

The test results of this report relate only to the tested sample(s) identified in this report. Manufacturer or whom it may concern should recognize the pass or fail of the test result.

1.2 Measurement Uncertainty

Test Item	Frequency Range	Uncertainty (dB)
Conducted Emission	9kHz ~ 150KHz	2.7
	150kHz ~ 30MHz	2.8
Radiated Emission	9kHz ~ 30MHz	1.457
	30MHz ~ 1000MHz	6.300
	1000MHz ~ 18000MHz	5.474
	18000MHz ~ 26500MHz	5.630
	26500MHz ~ 40000MHz	5.054



2 EUT Description

Applicant	Mobile Action Technology Inc. 5F., No.205-3, Sec.3, Beishin Rd., Shindian City Taipei Taiwan 231
Manufacturer	Heisei Technology Co., Ltd. 2F.,No.5,Aly,8,Ln.45.,Baoping Rd.,Xindian Dist.,New Taipei City 231,Taiwan,R.O.C.
Product Type	Bluetooth 4.0 Low Energy Wristband
Trade Name	Q-Watch
Model No.	Q-77
FCC ID	Q7Z-16077R1
Frequency Range	Bluetooth LE: 2402 ~ 2480 MHz
Modulation Type	GFSK
Antenna Type	FPC Antenna
Antenna Gain	-1.14 dBi
RF Output Power	0.00075 W / -1.26 dBm

3 Test Methodology

3.1. Mode of Operation

Decision of Test ATL has verified the construction and function in typical operation. All the test modes were carried out with the EUT in normal operation, which was shown in this test report and defined as:

Test Mode
Mode 1: Normal Operation Mode
Mode 2: Bluetooth LE Link Mode

Software used to control the EUT for staying in continuous transmitting mode was programmed.

After verification, all tests were carried out with the worst case test modes as shown below except radiated spurious emission below 1GHz and power line conducted emissions below 30MHz, which worst case was in normal link mode only.

By preliminary testing and verifying three axis (X, Y and Z) position of EUT transmitted status, it was found that "X axis" position was the worst, then the final test was executed the worst condition and test data were recorded in this report.

Note: The EUT was programmed to be in continuously transmitting mode and the transmit duty cycle is not less than 98%.

Tested System Details

The types for all equipments, plus descriptions of all cables used in the tested system (including inserted cards) are:

	Product	Manufacturer	Model Number	Serial Number	Power Cord
1.	Bluetooth Tester	R & S	CBT	100350	NA

3.2. EUT Exercise Software

1	Setup the EUT shown on 3.3.
2	Turn on the power of all equipment.
3	Turn Bluetooth function link to Bluetooth Tester
4	EUT run test program.

Measurement Software	
1	EZ-EMC Ver. ATL-03A1-1
2	EZ-EMC Ver ATL-ITC-3A1-1

3.3. Configuration of Test System Details

AC Power Conducted Emission

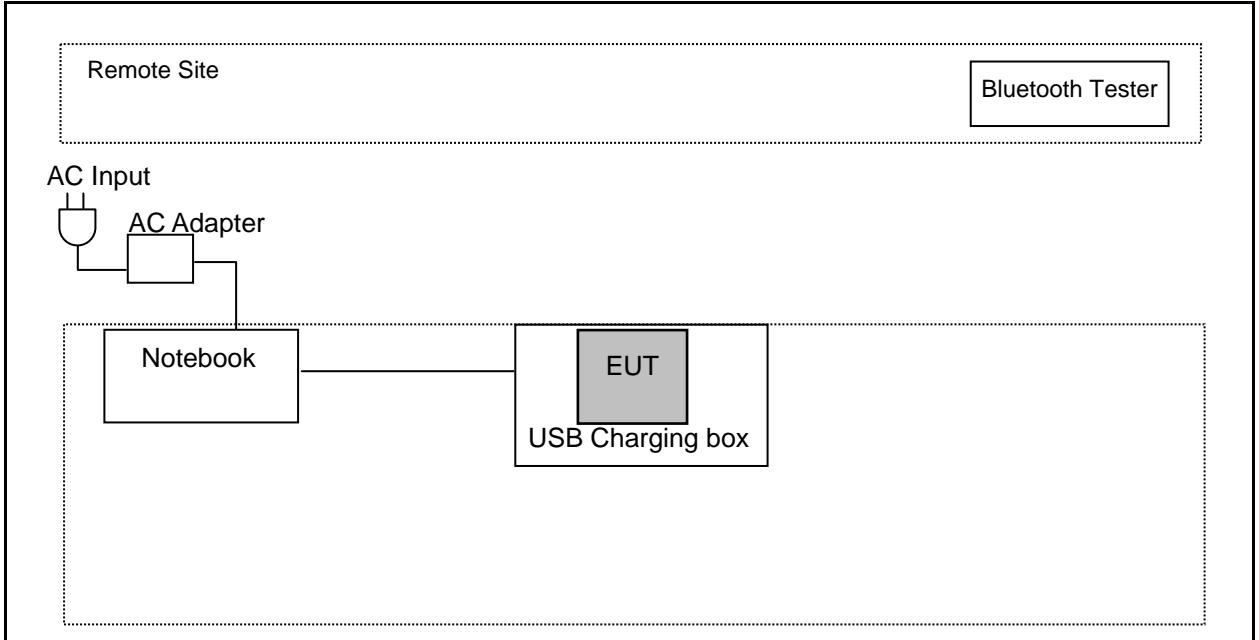

Radiated Emissions

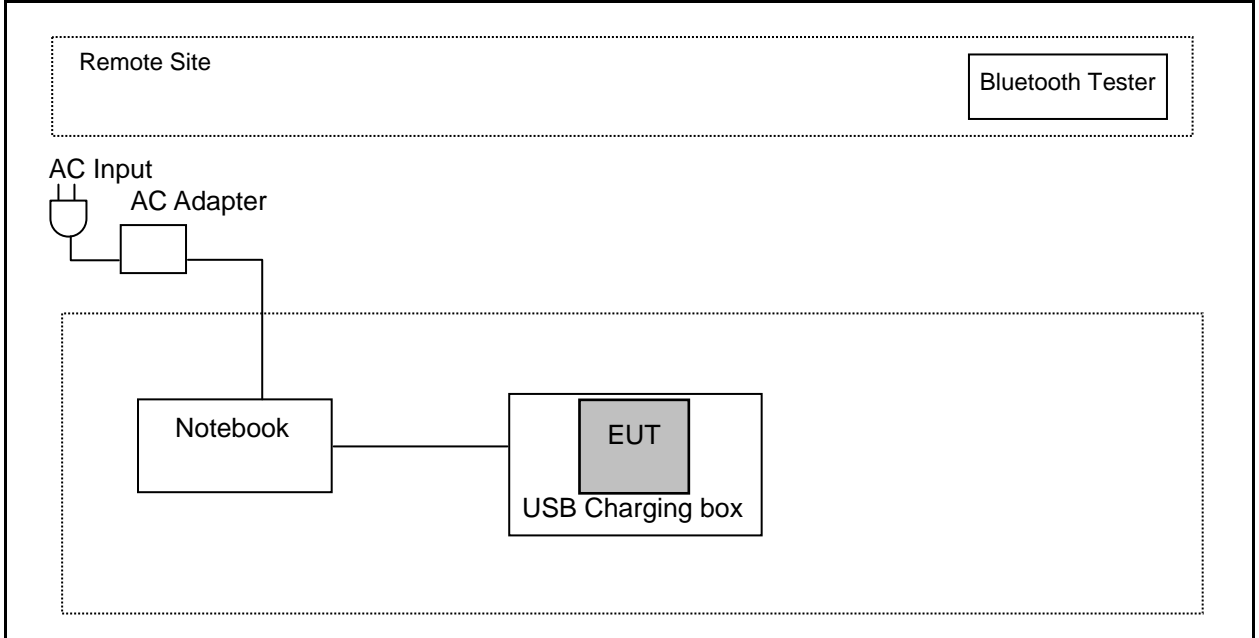

3.4. Test Site Environment

Items	Required (IEC 60068-1)	Actual
Temperature (°C)	15-35	26
Humidity (%RH)	25-75	60
Barometric pressure (mbar)	860-1060	950

4 Conducted Emission Measurement

4.1. Limit

Frequency (MHz)	Quasi-peak	Average
0.15 - 0.5	66 to 56	56 to 46
0.50 - 5.0	56	46
5.0 - 30.0	60	50

4.2. Test Instruments

Describe	Manufacturer	Model Number	Serial Number	Cal. Date	Remark
Test Receiver	R&S	ESCI	100367	06/25/2015	1 year
LISN	R&S	ENV216	101040	03/15/2016	1 year
LISN	R&S	ENV216	101041	03/07/2016	1 year
RF Cable	Woken	00100D1380194M	TE-02-02	06/26/2015	1 year
Test Site	ATL	TE02	TE02	N.C.R.	-----

Note: N.C.R. = No Calibration Request.

4.3. Test Setup

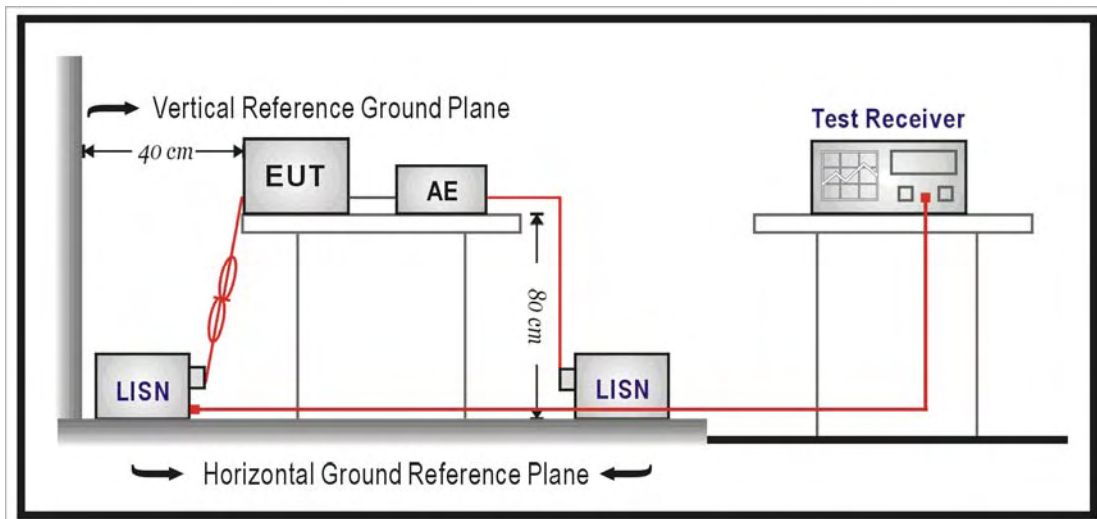

4.4. Test Procedure

The EUT and simulators are connected to the main power through a line impedance stabilization network (L.I.S.N.). This provides a 50 ohm /50uH coupling impedance for the measuring equipment. The peripheral devices are also connected to the main power through a LISN that provides a 50ohm/50uH coupling impedance with 50ohm termination.

For A.C. mains conducted interference, measured both sides of A.C. lines and carried out using quasi-peak and average detector receivers of maximum conducted interference.

Conducted emissions were investigated over the frequency range from 0.15 MHz to 30 MHz using a receiver bandwidth of 9 kHz. The equipment under test (EUT) shall be meet the limits in section 4.1, as applicable, including the average limit and the quasi-peak limit when using respectively, an average detector and quasi-peak detector measured in accordance with the methods described of related standard. The voltage limits shall be met. If the average limit is met when using a quasi-peak detector receiver, the EUT shall be deemed to meet both limits and measurement with the average detector receiver is unnecessary.

If the reading of the measuring receiver shows fluctuations close to the limit, the reading shall be observed for at least 15 s at each measurement frequency; the higher reading shall be recorded with the exception of any brief isolated high reading which shall be ignored.



4.5. Test Result

Standard:	FCC Part 15C	Line:	L1
Test item:	Conducted Emission	Power:	AC 120V/60Hz
Model Number:	Q-77	Temp.(°C)/Hum.(%RH):	26(°C)/60%RH
Mode:	1	Date:	04/20/2016
		Test By:	Eric Ou Yang
Description:			

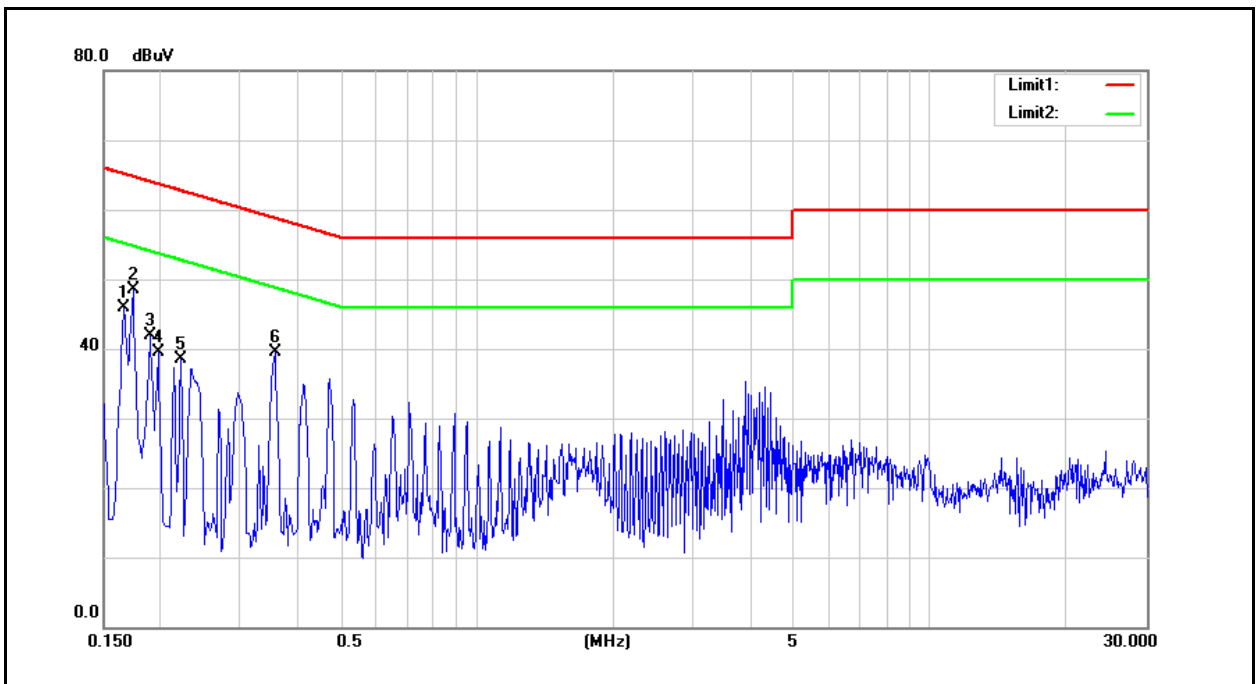

No.	Frequency (MHz)	QP reading (dBuV)	AVG reading (dBuV)	Correction factor (dB)	QP result (dBuV)	AVG result (dBuV)	QP limit (dBuV)	AVG limit (dBuV)	QP margin (dB)	AVG margin (dB)	Remark
1	0.1660	28.75	4.16	9.60	38.35	13.76	65.16	55.16	-26.81	-41.40	Pass
2	0.1740	33.87	24.48	9.60	43.47	34.08	64.77	54.77	-21.30	-20.69	Pass
3	0.1900	23.50	1.52	9.59	33.09	11.11	64.04	54.04	-30.95	-42.93	Pass
4	0.1980	23.81	0.84	9.59	33.40	10.43	63.69	53.69	-30.29	-43.26	Pass
5	0.2220	20.29	-0.75	9.59	29.88	8.84	62.74	52.74	-32.86	-43.90	Pass
6	0.3580	27.81	26.50	9.60	37.41	36.10	58.77	48.77	-21.36	-12.67	Pass

Note: 1. Result (dBuV) = Correction factor (dB) + Reading(dBuV).

2. Correction factor (dB) = Cable loss (dB) + L.I.S.N. factor (dB).



Standard:	FCC Part 15C	Line:	N
Test item:	Conducted Emission	Power:	AC 120V/60Hz
Model Number:	Q-77	Temp.(°C)/Hum.(%RH):	26(°C)/60%RH
Mode:	1	Date:	04/20/2016
		Test By:	Eric Ou Yang

Description:

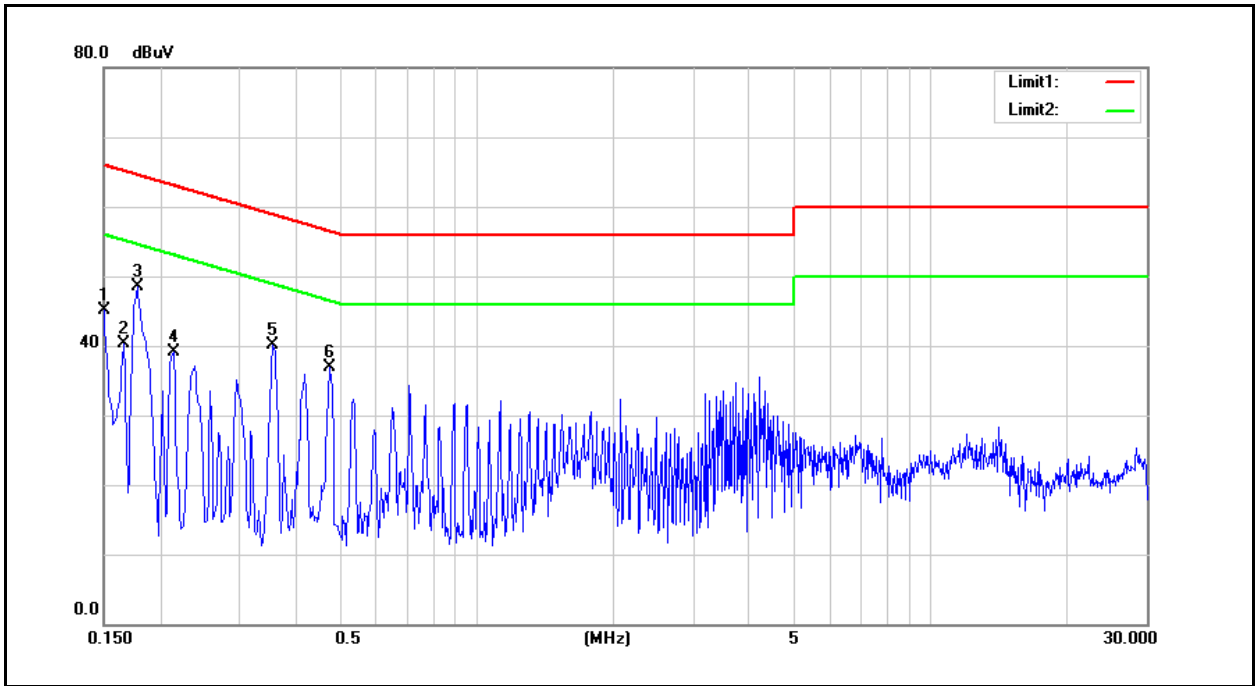

No.	Frequency (MHz)	QP reading (dBuV)	AVG reading (dBuV)	Correction factor (dB)	QP result (dBuV)	AVG result (dBuV)	QP limit (dBuV)	AVG limit (dBuV)	QP margin (dB)	AVG margin (dB)	Remark
1	0.1500	31.21	4.76	9.59	40.80	14.35	66.00	56.00	-25.20	-41.65	Pass
2	0.1660	27.46	3.90	9.59	37.05	13.49	65.16	55.16	-28.11	-41.67	Pass
3	0.1780	38.05	27.40	9.58	47.63	36.98	64.58	54.58	-16.95	-17.60	Pass
4	0.2140	21.48	-0.31	9.58	31.06	9.27	63.05	53.05	-31.99	-43.78	Pass
5	0.3540	29.66	28.52	9.59	39.25	38.11	58.87	48.87	-19.62	-10.76	Pass
6	0.4740	26.66	25.21	9.60	36.26	34.81	56.44	46.44	-20.18	-11.63	Pass

Note: 1. Result (dBuV) = Correction factor (dB) + Reading(dBuV).
 2. Correction factor (dB) = Cable loss (dB) + L.I.S.N. factor (dB).



5 Radiated Emission Measurement

5.1. Limit

According to §15.209(a), except as provided elsewhere in this subpart, the emissions from an intentional radiator shall not exceed the field strength levels specified in the following table:

Frequency (MHz)	Field Strength ($\mu\text{V}/\text{m}$ at meter)	Measurement Distance (meters)
0.009 – 0.490	2400 / F (kHz)	300
0.490 – 1.705	24000 / F (kHz)	30
1.705 – 30.0	30	30
30 - 88	100**	3
88-216	150**	3
216-960	200**	3
Above 960	500	3

** Except as provided in paragraph (g), fundamental emissions from intentional radiators operating under this Section shall not be located in the frequency bands 54-72 MHz, 76-88 MHz, 174-216 MHz or 470-806 MHz. However, operation within these frequency bands is permitted under other sections of this Part, e.g., Sections 15.231 and 15.241.

5.2. Test Instruments

3 Meter Chamber					
Equipment	Manufacturer	Model Number	Serial Number	Cal. Date	Cal. Period
RF Pre-selector	Agilent	N9039A	MY46520256	01/08/2016	1 year
Spectrum Analyzer	Agilent	E4446A	MY46180578	01/08/2016	1 year
Pre Amplifier	Agilent	8449B	3008A02237	10/07/2015	1 year
Pre Amplifier	Agilent	8447D	2944A11119	01/11/2016	1 year
Broadband Antenna	Schwarzbeck	VULB9168	416	09/25/2015	1 year
Horn Antenna (1~18GHz)	SCHWARZBECK MESS-ELEKTRONIK	BBHA9120D	9120D-550	06/12/2015	1 year
Horn Antenna (18~40GHz)	ETS	3116	86467	09/01/2015	1 year
Loop Antenna	COM-POWER CORPORATION	AL-130	121014	02/01/2016	1 year
Microwave Cable	EMCI	EMC102-KM-KM-14000	151001	10/15/2015	1 year
Microwave Cable	EMCI	EMC-104-SM-SM-14000	140202	10/15/2015	1 year
Microwave Cable	EMCI	EMC104-SM-SM-600	140301	10/15/2015	1 year
Test Site	ATL	TE01	888001	08/27/2015	1 year

Note: N.C.R. = No Calibration Request.

5.3. Setup

9kHz ~ 30MHz

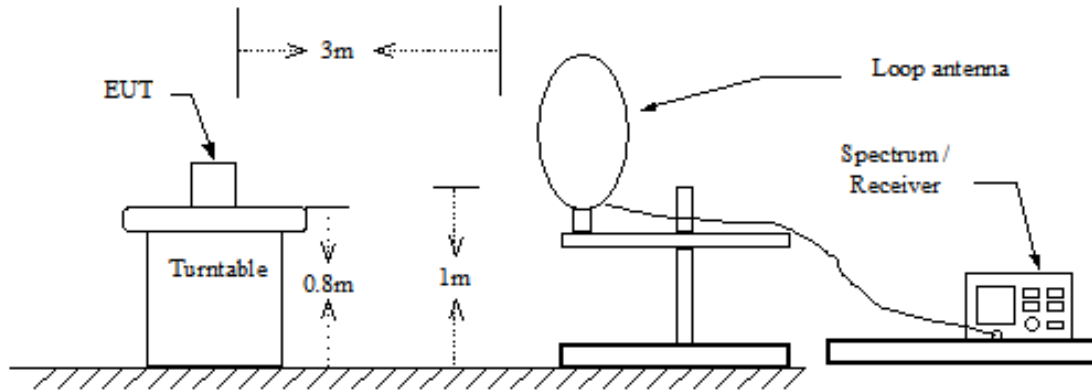

Below 1GHz

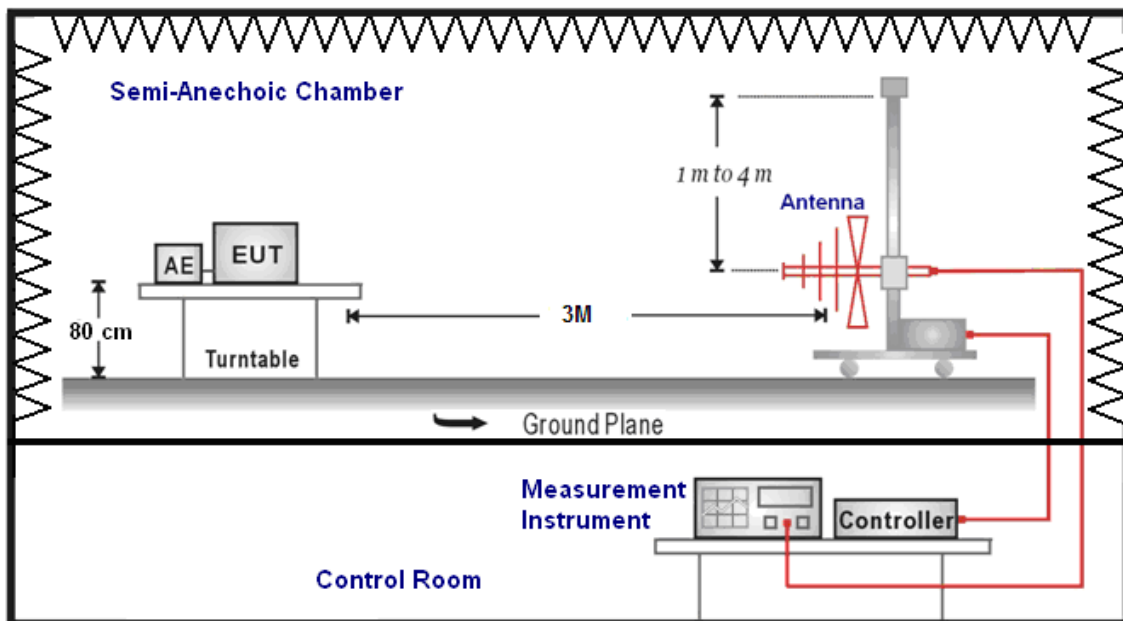

Above 1GHz

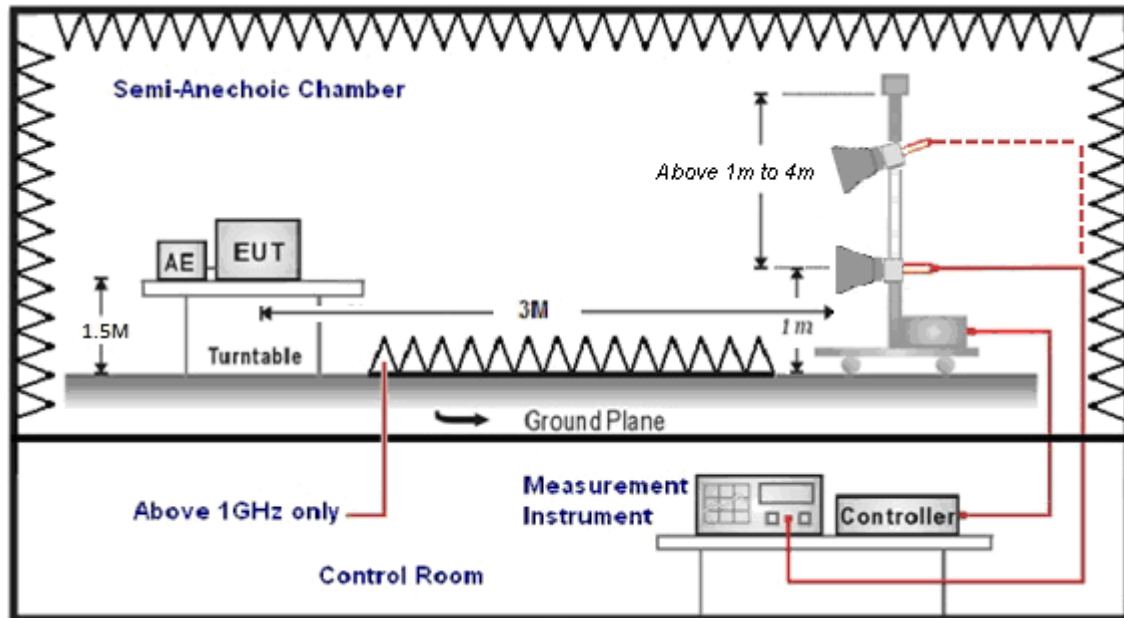

5.4. Test Procedure

Final radiation measurements were made on a three-meter, Semi Anechoic Chamber. The EUT system was placed on a nonconductive turntable which is 0.8 or 1.5 meters height (below 1GHz use 0.8m turntable / above 1GHz use 1.5m turntable), top surface 1.0 x 1.5 meter. The spectrum was examined from 250 MHz to 2.5 GHz in order to cover the whole spectrum below 10th harmonic which could generate from the EUT. During the test, EUT was set to transmit continuously & Measurements spectrum range from 9 kHz to 26.5 GHz is investigated.

For measurements below 1 GHz the resolution bandwidth is set to 100 kHz for peak detection measurements or 120 kHz for quasi-peak detection measurements. Peak detection is used unless otherwise noted as quasi-peak.

For measurements above 1 GHz the resolution bandwidth is set to 1 MHz, and then the video bandwidth is set to 1 MHz for peak measurements and 10 Hz for average measurements when Duty cycle >98% / 1/T for average measurements when Duty cycle <98%. A nonconductive material surrounded the EUT to supporting the EUT for standing on three orthogonal planes. At each condition, the EUT was rotated 360 degrees, and the antenna was raised and lowered from one to four meters to find the maximum emission levels. Measurements were taken using both horizontal and vertical antenna polarization.



SCHWARZBECK MESS-ELEKTRONIK Biconilog Antenna at 3 Meter and the SCHWARZBECK Double Ridged Guide Antenna was used in frequencies 1 – 26.5 GHz at a distance of 1 meter. All test results were extrapolated to equivalent signal at 3 meters utilizing an inverse linear distance extrapolation Factor (20dB/decade).

For testing above 1GHz, the emission level of the EUT in peak mode was 20dB lower than average limit (that means the emission level in peak mode also complies with the limit in average mode), then testing will be stopped and peak values of EUT will be reported, otherwise, the emissions will be measured in average mode again and reported.

Appropriate preamplifiers were used for improving sensitivity and precautions were taken to avoid overloading or desensitizing the spectrum analyzer. No post – detector video filters were used in the test.

The spectrum analyzer's 6 dB bandwidth was set to 1 MHz, and the analyzer was operated in the peak detection mode, for frequencies both below and up 1 GHz. The average levels were obtained by subtracting the duty cycle correction factor from the peak readings.

The following procedures were used to convert the emission levels measured in decibels referenced to 1 microvolt (dBuV) into field intensity in micro volts pre meter (uV/m).

The actual field intensity in decibels referenced to 1 microvolt in to field intensity in micro volts per meter (dBuV/m).

The actual field intensity in decibels referenced to 1 microvolt per meter (dBuV/m) is determined by algebraically adding the measured reading in dBuV, the antenna factor (dB), and cable loss (dB) and Subtracting the gain of preamplifier (dB) is auto calculate in spectrum analyzer.

$$(1) \text{ Amplitude (dBuV/m) = FI (dBuV) +AF (dBuV) +CL (dBuV)-Gain (dB)}$$

FI= Reading of the field intensity.

AF= Antenna factor.

CL= Cable loss.

P.S Amplitude is auto calculate in spectrum analyzer.

$$(2) \text{ Actual Amplitude (dBuV/m) = Amplitude (dBuV)-Dis(dB)}$$

The FCC specified emission limits were calculated according the EUT operating frequency and by following linear interpolation equations:

(a) For fundamental frequency : Transmitter Output < +30dBm

(b) For spurious frequency : Spurious emission limits = fundamental emission limit /10

Data of measurement within this frequency range without mark in the table above means the reading of emissions are attenuated more than 20dB below the permissible limits or the field strength is too small to be measured.



5.5. Test Result

Below 1GHz

Standard:	FCC Part 15C	Test Distance:	3m
Test item:	Radiated Emission	Power:	AC 120V/60Hz
Model Number:	Q-77	Temp.(°C)/Hum.(%RH):	26(°C)/60%RH
Mode:	1	Date:	04/18/2016
		Test By:	Eric Ou Yang

Frequency (MHz)	Reading (dBuV)	Correct Factor (dB/m)	Result (dBuV/m)	Limit (dBuV/m)	Margin (dB)	Remark	Ant.Polar. H / V
215.0000	41.15	-12.02	29.13	43.50	-14.37	QP	H
300.0000	37.42	-8.47	28.95	46.00	-17.05	QP	H
398.5000	39.77	-6.64	33.13	46.00	-12.87	QP	H
643.0000	34.86	-1.73	33.13	46.00	-12.87	QP	H
799.5000	31.29	0.98	32.27	46.00	-13.73	QP	H
867.0000	34.23	2.38	36.61	46.00	-9.39	QP	H
399.5000	39.98	-6.61	33.37	46.00	-12.63	QP	V
501.0000	36.21	-4.64	31.57	46.00	-14.43	QP	V
599.0000	35.73	-2.50	33.23	46.00	-12.77	QP	V
642.0000	35.30	-1.74	33.56	46.00	-12.44	QP	V
797.0000	34.16	0.94	35.10	46.00	-10.90	QP	V
987.0000	34.22	4.51	38.73	54.00	-15.27	QP	V

Note:1.Result (dBuV) = Correction factor (dB) + Reading(dBuV).

2.Correction factor (dB/m) = Antenna Factor (dB/m) + Cable loss (dB) – Pre-Amplifier gain (dB).

3.No emission found between lowest internal used/generated frequencies to 30MHz (9 kHz~30MHz).



Above 1GHz

Standard:		FCC Part 15C		Test Distance:		3m	
Test item:		Radiated Emission		Power:		AC 120V/60Hz	
Model Number:		Q-77		Temp.(°C)/Hum.(%RH):		26(°C)/60%RH	
Mode:		2		Date:		04/18/2016	
Frequency:		2402MHz		Test By:		Eric Ou Yang	
Frequency (MHz)	Reading (dBuV)	Correct Factor (dB/m)	Result (dBuV/m)	Limit (dBuV/m)	Margin (dB)	Remark	Ant.Polar. H / V
4804.000	38.85	7.43	46.28	74.00	-27.72	peak	H
7206.000	35.63	13.36	48.99	74.00	-25.01	peak	H
4804.000	41.61	7.43	49.04	74.00	-24.96	peak	V
7206.000	36.01	13.36	49.37	74.00	-24.63	peak	V

Standard:		FCC Part 15C		Test Distance:		3m	
Test item:		Radiated Emission		Power:		AC 120V/60Hz	
Model Number:		Q-77		Temp.(°C)/Hum.(%RH):		26(°C)/60%RH	
Mode:		2		Date:		04/18/2016	
Frequency:		2440MHz		Test By:		Eric Ou Yang	
Frequency (MHz)	Reading (dBuV)	Correct Factor (dB/m)	Result (dBuV/m)	Limit (dBuV/m)	Margin (dB)	Remark	Ant.Polar. H / V
4880.000	41.26	7.71	48.97	74.00	-25.03	peak	H
7320.000	37.38	13.70	51.08	74.00	-22.92	peak	H
4880.000	45.55	7.71	53.26	74.00	-20.74	peak	V
4880.000	36.25	7.71	43.96	54.00	-10.04	AVG	V
7320.000	37.42	13.70	51.12	74.00	-22.88	peak	V

Note:1.Result (dBuV) = Correction factor (dB) + Reading(dBuV).

2.Correction factor (dB/m) = Antenna Factor (dB/m) + Cable loss (dB) – Pre-Amplifier gain (dB).



Standard:	FCC Part 15C	Test Distance:	3m
Test item:	Radiated Emission	Power:	AC 120V/60Hz
Model Number:	Q-77	Temp.(°C)/Hum.(%RH):	26(°C)/60%RH
Mode:	2	Date:	04/18/2016
Frequency:	2480MHz	Test By:	Eric Ou Yang

Frequency (MHz)	Reading (dBuV)	Correct Factor (dB/m)	Result (dBuV/m)	Limit (dBuV/m)	Margin (dB)	Remark	Ant.Polar. H / V
4960.000	43.36	7.98	51.34	74.00	-22.66	peak	H
7440.000	42.59	14.07	56.66	74.00	-17.34	peak	H
7440.000	33.34	14.07	47.41	54.00	-6.59	AVG	H
4960.000	43.72	7.98	51.70	74.00	-22.30	peak	V
7440.000	45.04	14.07	59.11	74.00	-14.89	peak	V
7440.000	34.40	14.07	48.47	54.00	-5.53	AVG	V

Note:1.Result (dBuV) = Correction factor (dB) + Reading(dBuV).

2.Correction factor (dB/m) = Antenna Factor (dB/m) + Cable loss (dB) – Pre-Amplifier gain (dB).



Band Edge

Standard:		FCC Part 15C		Test Distance:		3m	
Test item:		Radiated Emission		Power:		AC 120V/60Hz	
Model Number:		Q-77		Temp.(°C)/Hum.(%RH):		26(°C)/60%RH	
Mode:		2		Date:		04/18/2016	
Frequency:		2402 MHz		Test By:		Eric Ou Yang	
Frequency (MHz)	Reading (dBuV)	Correct Factor (dB/m)	Result (dBuV/m)	Limit (dBuV/m)	Margin (dB)	Remark	Ant.Polar. H / V
2368.300	46.31	-0.30	46.01	74.00	-27.99	peak	H
2390.000	40.11	-0.22	39.89	74.00	-34.11	peak	H
2329.360	45.12	-0.45	44.67	74.00	-29.33	peak	V
2390.000	41.50	-0.22	41.28	74.00	-32.72	peak	V

Standard:		FCC Part 15C		Test Distance:		3m	
Test item:		Radiated Emission		Power:		AC 120V/60Hz	
Model Number:		Q-77		Temp.(°C)/Hum.(%RH):		26(°C)/60%RH	
Mode:		2		Date:		04/18/2016	
Frequency:		2480 MHz		Test By:		Eric Ou Yang	
Frequency (MHz)	Reading (dBuV)	Correct Factor (dB/m)	Result (dBuV/m)	Limit (dBuV/m)	Margin (dB)	Remark	Ant.Polar. H / V
2483.500	54.09	0.14	54.23	74.00	-19.77	peak	H
2483.500	34.69	0.14	34.83	54.00	-19.17	AVG	H
2484.020	55.39	0.14	55.53	74.00	-18.47	peak	H
2484.020	34.79	0.14	34.93	54.00	-19.07	AVG	H
2483.500	54.65	0.14	54.79	74.00	-19.21	peak	V
2483.500	33.77	0.14	33.91	54.00	-20.09	AVG	V
2483.740	53.98	0.14	54.12	74.00	-19.88	peak	V
2483.740	33.74	0.14	33.88	54.00	-20.12	AVG	V

Note:1.Result (dBuV) = Correction factor (dB) + Reading(dBuV).

2.Correction factor (dB/m) = Antenna Factor (dB/m) + Cable loss (dB) – Pre-Amplifier gain (dB).

6 Maximum Conducted Output Power Measurement

6.1. Limit

For systems using digital modulation in the 2400-2483.5MHz, the limit for peak output power is 30dBm.

6.2. Test Setup

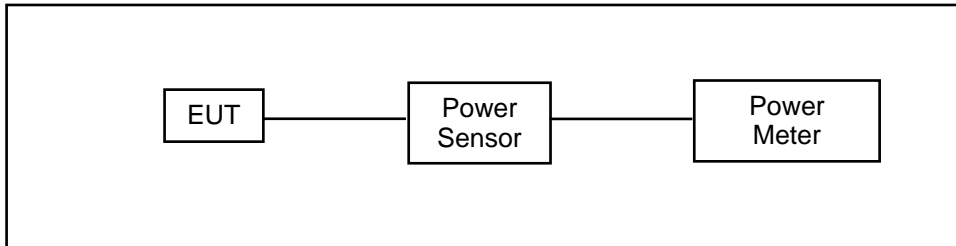

6.3. Test Instruments

Equipment	Manufacturer	Model Number	Serial Number	Cal. Date	Remark
Power Sensor	Anritsu	MA2411B	1126022	08/24/2015	1 year
Power Meter	Anritsu	ML2495A	1135009	08/24/2015	1 year
Microwave Cable	EMCI	EMC104-SM-S M-1500	140303	02/23/2016	1 year
Test Site	ATL	TE05	TE05	N.C.R.	-----

Note: N.C.R. = No Calibration Request.

6.4. Test Procedure

The tests below are run with the EUT's transmitter set at high power in TX mode. The EUT is needed to force selection of output power level and channel number. While testing, EUT was set to transmit continuously. Remove the Subjective device's antenna and connect the RF output port to power sensor..

6.5. Test Result

Model Number	Q-77				
Test Item	Maximum Conducted Output Power				
Test Mode	Mode 2: Bluetooth LE Link Mode				
Date of Test	04/14/2016				
Frequency (MHz)	Average Power		Peak Power		Limit (dBm)
	(dBm)	(W)	(dBm)	(W)	
2402	-4.52	0.00035	-3.71	0.00043	< 30
2440	-3.35	0.00046	-2.56	0.00055	< 30
2480	-2.04	0.00063	-1.26	0.00075	< 30

Note: The relevant measured result has the offset with cable loss already.

7 6dB RF Bandwidth Measurement

7.1. Limit

6dB RF Bandwidth: Systems using digital modulation techniques may operate in the 2400–2483.5 MHz bands. The minimum 6 dB band-width shall be at least 500 kHz.

7.2. Test Setup

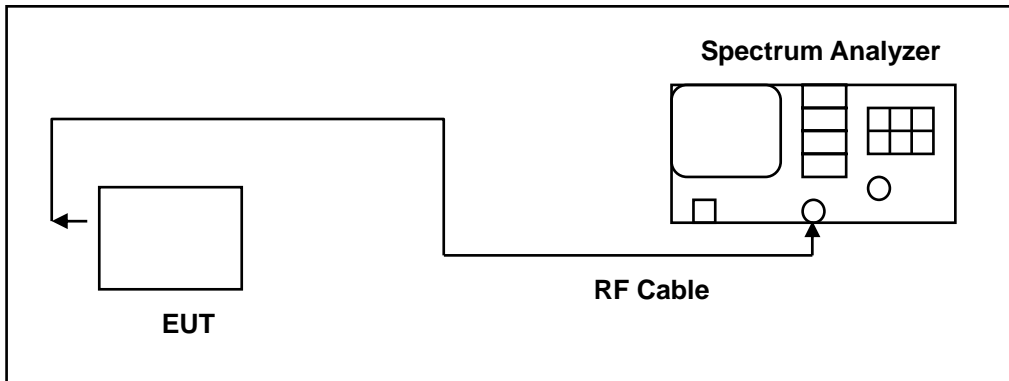

7.3. Test Instruments

Equipment	Manufacturer	Model Number	Serial Number	Cal. Date	Remark
Spectrum Analyzer	Agilent	E4445A	MY45300744	12/15/2015	1 year
Microwave Cable	EMCI	EMC104-SM-S M-1500	140303	02/23/2016	1 year
Test Site	ATL	TE05	TE05	N.C.R.	-----

Note: N.C.R. = No Calibration Request.

7.4. Test Procedure

The EUT tested to DTS test procedure of KDB558074D01 for compliance to FCC 47CFR 15.247 requirements.

6dB RF Bandwidth: The antenna port of the EUT was connected to the input of a spectrum analyzer. Analyzer RBW was set to 100 kHz. For each RF output channel investigated, the spectrum analyzer center frequency was set to the channel carrier. A peak output reading was taken, a DISPLAY line was drawn 6 dB lower than peak level. The 6 dB bandwidth was determined from where the channel output spectrum intersected the display line.

The test was performed at 3 channels (Channel low, middle, high)



7.5. Test Result

Model Number	Q-77	
Test Item	6dB RF Bandwidth	
Test Mode	Mode 2: Bluetooth LE Link Mode	
Date of Test	04/14/2016	
Frequency (MHz)	6dB Bandwidth (kHz)	6dB RF Bandwidth Limit (kHz)
2402	694.6	> 500
2440	680.2	> 500
2480	698.1	> 500



7.6. Test Graphs

Mode 2: Bluetooth LE Link Mode	
2402 MHz	
2440 MHz	
2480 MHz	

8 Maximum Power Density Measurement

8.1. Limit

For digitally modulated systems, the power spectral density conducted from the intentional radiator to the antenna shall not be greater than 8 dBm in any 3 kHz band during any time interval of continuous transmission.

8.2. Test Setup

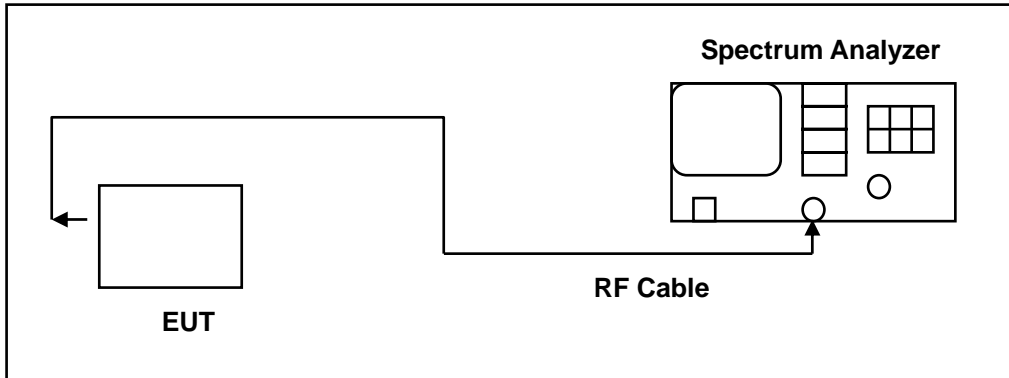

8.3. Test Instruments

Equipment	Manufacturer	Model Number	Serial Number	Cal. Date	Remark
Spectrum Analyzer	Agilent	E4445A	MY45300744	12/15/2015	1 year
Microwave Cable	EMCI	EMC104-SM-S M-1500	140303	02/23/2016	1 year
Test Site	ATL	TE05	TE05	N.C.R.	-----

Note: N.C.R. = No Calibration Request.

8.4. Test Procedure

The EUT tested to DTS test procedure of KDB558074D01 for compliance to FCC 47CFR 15.247 requirements.

1. Set analyzer center frequency to DTS channel center frequency.
2. Set the span to 1.5 times the DTS bandwidth.
3. Set the RBW to: $3 \text{ kHz} \leq \text{RBW} \leq 100 \text{ kHz}$.
4. Set the VBW $\geq 3 \times \text{RBW}$.
5. Detector = peak.
6. Sweep time = auto couple.
7. Trace mode = max hold.
8. Allow trace to fully stabilize.
9. Use the peak marker function to determine the maximum amplitude level within the RBW.
10. If measured value exceeds limit, reduce RBW (no less than 3 kHz) and repeat.

**8.5. Test Result**

Model Number	Q-77	
Test Item	Maximum Power Density	
Test Mode	Mode 2: Bluetooth LE Link Mode	
Date of Test	04/15/2016	
Frequency (MHz)	Reading (dBm/3KHz)	Limit (dBm)
2402	-19.982	< 8
2440	-18.795	< 8
2480	-17.020	< 8



8.6. Test Graphs

Mode 2: Bluetooth LE Link Mode	
2402 MHz	
2440 MHz	
2480 MHz	

9 Out of Band Conducted Emissions Measurement

9.1. Limit

In any 100 kHz bandwidth outside the frequency band in which the spread spectrum or digitally modulated intentional radiator is operating, the radio frequency power that is produced by the intentional radiator shall be at least 20 dB below that in the 100 kHz bandwidth within the band that contains the highest level of the desired power

9.2. Test Setup

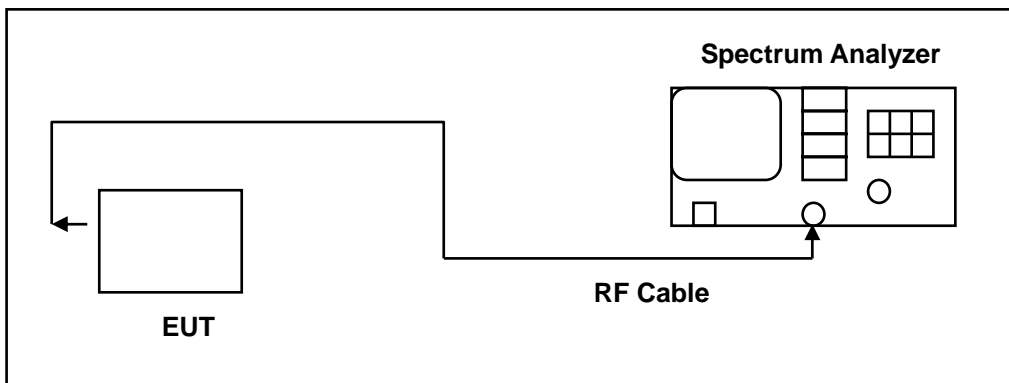

9.3. Test Instruments

Equipment	Manufacturer	Model Number	Serial Number	Cal. Date	Remark
Spectrum Analyzer	Agilent	E4445A	MY45300744	12/15/2015	1 year
Spectrum Analyzer	Agilent	E4408B	MY45107753	07/27/2015	1 year
Microwave Cable	EMCI	EMC104-SM-S M-1500	140303	02/23/2016	1 year
Test Site	ATL	TE05	TE05	N.C.R.	-----

Note: N.C.R. = No Calibration Request.

9.4. Test Procedure

In any 100 kHz bandwidth outside the EUT pass band, the RF power produced by the modulation products of the spreading sequence, the information sequence, and the carrier frequency shall be at least 20 dB below that of the maximum in-band 100 kHz emission, antenna output of the EUT was coupled directly to spectrum analyzer; if an external attenuator and/or cable was used, these losses are compensated for with the analyzer OFFSET function.

All other types of emissions from the EUT shall meet the general limits for radiated frequencies outside the pass band.

The test was performed at 3 channels.



9.5. Test Graphs

Reference level

Mode 2: Bluetooth LE Link Mode	
2402 MHz	<p>Agilent Spectrum Analyzer - Sweep 54 Center Freq 2.40200000 GHz Ref Offset 0.5 dB Ref 10.00 dBm Mkr1 2.402 014 3 GHz -4.548 dBm Center 2.4020000 GHz #Res BW 100 kHz #VBW 300 kHz Span 1.100 MHz Sweep 1.000 ms (1001 pts)</p>
2440 MHz	<p>Agilent Spectrum Analyzer - Sweep 54 Center Freq 2.44000000 GHz Ref Offset 0.5 dB Ref 10.00 dBm Mkr1 2.440 020 9 GHz -3.215 dBm Center 2.4400000 GHz #Res BW 100 kHz #VBW 300 kHz Span 1.100 MHz Sweep 1.000 ms (1001 pts)</p>
2480 MHz	<p>Agilent Spectrum Analyzer - Sweep 54 Center Freq 2.48000000 GHz Ref Offset 0.5 dB Ref 10.00 dBm Mkr1 2.480 011 0 GHz -1.794 dBm Center 2.4800000 GHz #Res BW 100 kHz #VBW 300 kHz Span 1.100 MHz Sweep 1.000 ms (1001 pts)</p>



Out of Band Conducted Emissions

Mode 2: Bluetooth LE Link Mode

2402 MHz

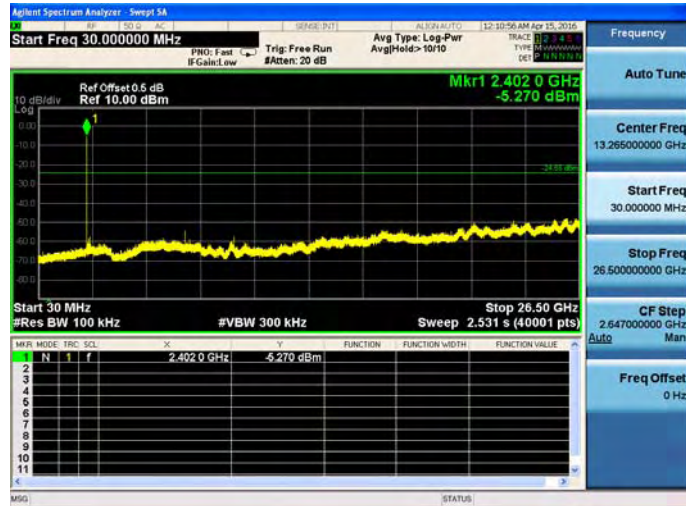

2440 MHz

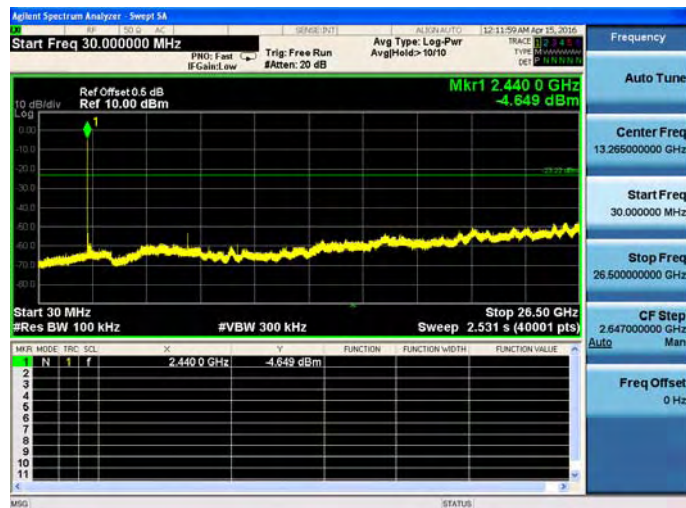

2480 MHz

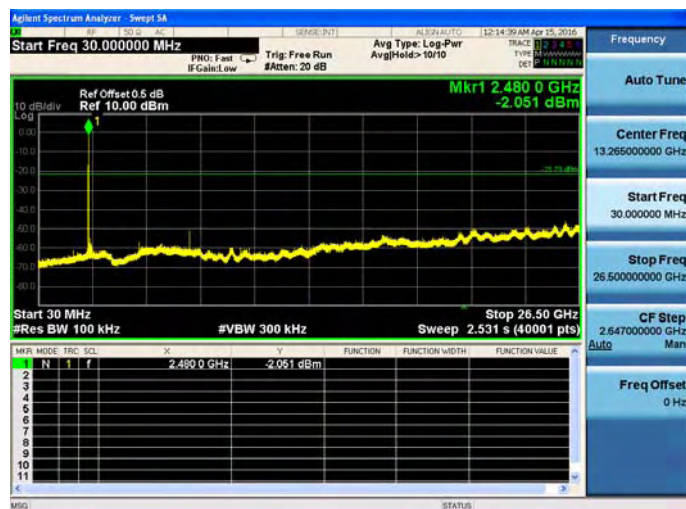



Conducted Band Edge

Mode 2: Bluetooth LE Link Mode

2402 MHz



2480 MHz





10 Antenna Measurement

10.1.Limit

For intentional device, according to 15.203, an intentional radiator shall be designed to ensure that no antenna other than that furnished by the responsible party shall be used with the device.

And According to 15.247 (b), if transmitting antennas of directional gain greater than 6 dBi are used, the power shall be reduced by the amount in dB that the directional gain of the antenna exceeds 6dBi.

10.2.Antenna Connector Construction

See section 2 – antenna information.