

## FCC 47 CFR PART 15 SUBPART C

Applicant : Mobile Action Technology Inc.  
Product Type : Bluetooth 4.0 Low Energy Wristband  
Trade Name : Q-Band  
Model Number : Q-66  
Test Specification : FCC 47 CFR PART 15 SUBPART C  
ANSI C63.10:2013  
Receive Date : May 23, 2016  
Test Period : May 25 ~ May 26, 2016  
Issue Date : Jun. 14, 2016

### Issue by

A Test Lab Techno Corp.  
No. 140-1, Changan Street, Bade District,  
Taoyuan City 33465, Taiwan (R.O.C)  
Tel : +886-3-2710188 / Fax : +886-3-2710190



Taiwan Accreditation Foundation accreditation number: 1330

**Note:** This report shall not be reproduced except in full, without the written approval of A Test Lab Techno Corp. This document may be altered or revised by A Test Lab Techno Corp. personnel only, and shall be noted in the revision section of the document. The client should not use it to claim product endorsement by TAF, or any government agencies. The test results in the report only apply to the tested sample.

**Revision History**

Rev.	Issue Date	Revisions	Revised By
00	Jun. 14, 2016	Initial Issue	Tiffany Lee

## Verification of Compliance

Issued Date: Jun. 14, 2016

Applicant : Mobile Action Technology Inc.  
Product Type : Bluetooth 4.0 Low Energy Wristband  
Trade Name : Q-Band  
Model Number : Q-66  
FCC ID : Q7Z-16066R1  
EUT Rated Voltage : DC 5V, 0.1A  
Test Voltage : 120 Vac / 60 Hz  
Applicable Standard : FCC 47 CFR PART 15 SUBPART C  
ANSI C63.10:2013

Test Result : Complied

Performing Lab. : A Test Lab Techno Corp.

No. 140-1, Changan Street, Bade District,  
Taoyuan City 33465, Taiwan (R.O.C)  
Tel : +886-3-2710188 / Fax : +886-3-2710190



Taiwan Accreditation Foundation accreditation number: 1330  
<http://www.atl-lab.com.tw/e-index.htm>

A Test Lab Techno Corp. tested the above equipment in accordance with the requirements set forth in the above standards. All indications of Pass/Fail in this report are opinions expressed by A Test Lab Techno Corp. based on interpretations and/or observations of test results. Measurement Uncertainties were not taken into account and are published for informational purposes only. The test results show that the equipment tested is capable of demonstrating compliance with the requirements as documented in this report.

Approved By



(Manager)

(Fly Lu)

Reviewed By

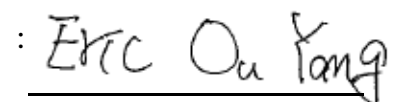

(Testing Engineer)

(Eric Ou Yang)

## TABLE OF CONTENTS

<b>1</b>	<b>General Information .....</b>	<b>6</b>
<b>2</b>	<b>EUT Description.....</b>	<b>7</b>
<b>3</b>	<b>Test Methodology.....</b>	<b>8</b>
	3.1. Mode of Operation.....	8
	3.2. EUT Exercise Software .....	8
	3.3. Configuration of Test System Details.....	9
	3.4. Test Site Environment.....	9
<b>4</b>	<b>Conducted Emission Measurement.....</b>	<b>10</b>
	4.1. Limit.....	10
	4.2. Test Instruments .....	10
	4.3. Test Setup .....	11
	4.4. Test Procedure .....	12
	4.5. Test Result.....	13
<b>5</b>	<b>Radiated Emission Measurement .....</b>	<b>15</b>
	5.1. Limit.....	15
	5.2. Test Instruments .....	15
	5.3. Setup.....	16
	5.4. Test Procedure .....	18
	5.5. Test Result.....	20
<b>6</b>	<b>Maximum Conducted Output Power Measurement.....</b>	<b>24</b>
	6.1. Limit.....	24
	6.2. Test Setup .....	24
	6.3. Test Instruments .....	24
	6.4. Test Procedure .....	24
	6.5. Test Result.....	24
<b>7</b>	<b>6dB RF Bandwidth Measurement.....</b>	<b>25</b>
	7.1. Limit.....	25
	7.2. Test Setup .....	25
	7.3. Test Instruments .....	25
	7.4. Test Procedure .....	25
	7.5. Test Result.....	26
	7.6. Test Graphs .....	27

<b>8</b>	<b>Maximum Power Density Measurement .....</b>	<b>28</b>
8.1.	Limit.....	28
8.2.	Test Setup .....	28
8.3.	Test Instruments .....	28
8.4.	Test Procedure .....	28
8.5.	Test Result.....	29
8.6.	Test Graphs .....	30
<b>9</b>	<b>Out of Band Conducted Emissions Measurement .....</b>	<b>31</b>
9.1.	Limit.....	31
9.2.	Test Setup .....	31
9.3.	Test Instruments .....	31
9.4.	Test Procedure .....	31
9.5.	Test Graphs .....	32
<b>10</b>	<b>Antenna Measurement .....</b>	<b>35</b>
10.1.	Limit.....	35
10.2.	Antenna Connector Construction .....	35

## 1 General Information

### 1.1 Summary of Test Result

Standard	Item	Result	Remark
15.207	AC Power Conducted Emission	PASS	----
15.247(d)	Transmitter Radiated Emissions	PASS	----
15.247(b)(3)	Max. Output Power	PASS	----
15.247(a)(2)	6dB RF Bandwidth	PASS	----
15.247(e)	Power Spectral Density	PASS	----
15.247(d)	Out of Band Conducted Spurious Emission	PASS	----
15.203	Antenna Requirement	PASS	----

The test results of this report relate only to the tested sample(s) identified in this report. Manufacturer or whom it may concern should recognize the pass or fail of the test result.

### 1.2 Measurement Uncertainty

Test Item	Frequency Range	Uncertainty (dB)
Conducted Emission	9kHz ~ 150KHz	2.7
	150kHz ~ 30MHz	2.8
Radiated Emission	9kHz ~ 30MHz	1.457
	30MHz ~ 1000MHz	6.300
	1000MHz ~ 18000MHz	5.474
	18000MHz ~ 26500MHz	5.630
	26500MHz ~ 40000MHz	5.054

## 2 EUT Description

Applicant	Mobile Action Technology Inc. 5F., No.205-3, Sec.3, Beishin Rd., Shindian City Taipei Taiwan 231
Manufacturer	Heisei Technology Co., Ltd. 2F.,No.5,Aly,8,Ln.45.,Baoxing Rd.,Xindian Dist.,New Taipei City 231,Taiwan,R.O.C.
Product Type	Bluetooth 4.0 Low Energy Wristband
Trade Name	Q-Band
Model No.	Q-66
FCC ID	Q7Z-16066R1
Frequency Range	Bluetooth LE: 2402 ~ 2480 MHz
Modulation Type	GFSK
Antenna Type	FPC Antenna
Antenna Gain	-2.84 dBi
RF Output Power	0.00587 W / 7.69 dBm

### 3 Test Methodology

#### 3.1. Mode of Operation

Decision of Test ATL has verified the construction and function in typical operation. All the test modes were carried out with the EUT in normal operation, which was shown in this test report and defined as:

Test Mode
Mode 1: Normal Operation Mode
Mode 2: Bluetooth LE Link Mode

Software used to control the EUT for staying in continuous transmitting mode was programmed.

After verification, all tests were carried out with the worst case test modes as shown below except radiated spurious emission below 1GHz and power line conducted emissions below 30MHz, which worst case was in normal link mode only.

By preliminary testing and verifying three axis (X, Y and Z) position of EUT transmitted status, it was found that "X axis" position was the worst, then the final test was executed the worst condition and test data were recorded in this report.

Note: The EUT was programmed to be in continuously transmitting mode and the transmit duty cycle is not less than 98%.

#### Tested System Details

The types for all equipments, plus descriptions of all cables used in the tested system (including inserted cards) are:

	Product	Manufacturer	Model Number	Serial Number	Power Cord
1.	Bluetooth Tester	R & S	CBT	100350	NA

#### 3.2. EUT Exercise Software

1	Setup the EUT shown on 3.3.
2	Turn on the power of all equipment.
3	Turn on Bluetooth function and link to Bluetooth tester
4	EUT run test program.

Measurement Software	
1	EZ-EMC Ver. ATL-03A1-1
2	EZ-EMC Ver ATL-ITC-3A1-1



### 3.3. Configuration of Test System Details

AC Power Conducted Emission

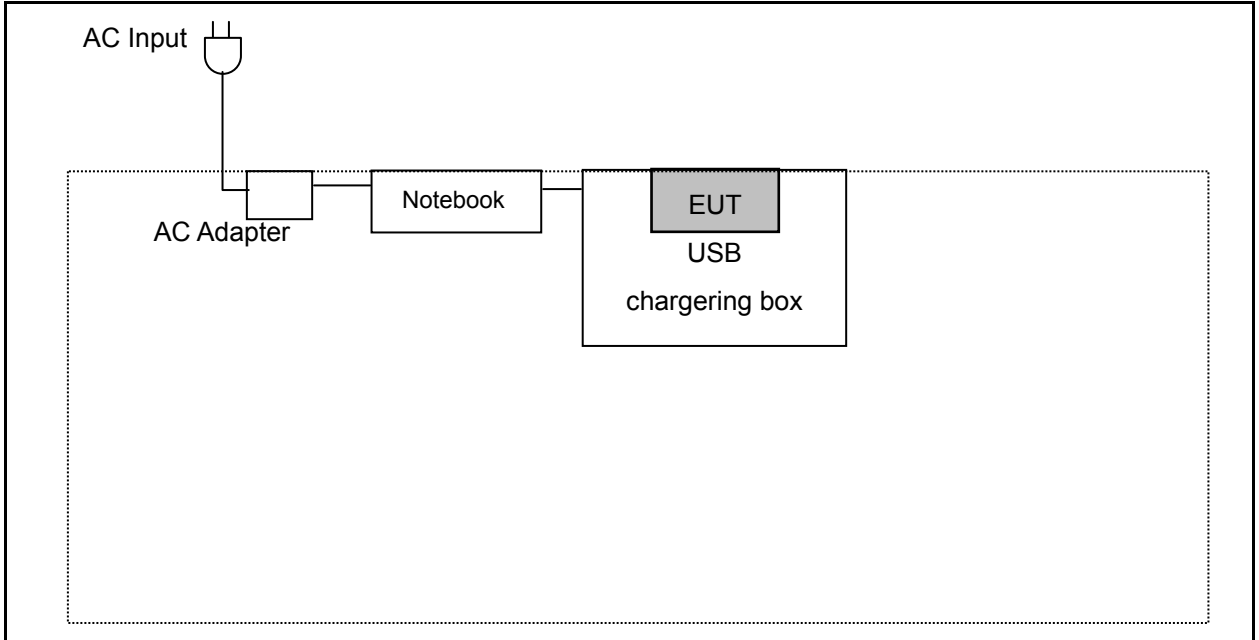

Radiated Emissions

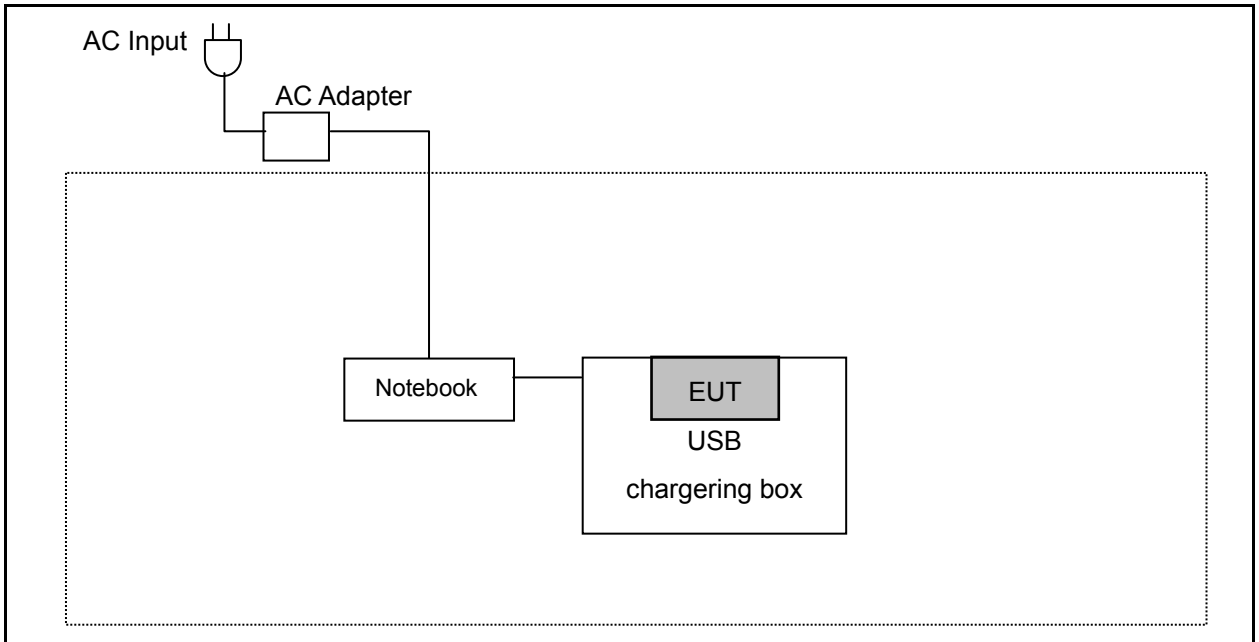

### 3.4. Test Site Environment

Items	Required (IEC 60068-1)	Actual
Temperature (°C)	15-35	26
Humidity (%RH)	25-75	60
Barometric pressure (mbar)	860-1060	950

## 4 Conducted Emission Measurement

### 4.1. Limit

Frequency (MHz)	Quasi-peak	Average
0.15 - 0.5	66 to 56	56 to 46
0.50 - 5.0	56	46
5.0 - 30.0	60	50

### 4.2. Test Instruments

Describe	Manufacturer	Model Number	Serial Number	Cal. Date	Remark
Test Receiver	R&S	ESCI	100367	06/25/2015	1 year
LISN	R&S	ENV216	101040	03/15/2016	1 year
LISN	R&S	ENV216	101041	03/07/2016	1 year
RF Cable	Woken	00100D1380194M	TE-02-02	06/26/2015	1 year
Test Site	ATL	TE02	TE02	N.C.R.	-----

Note: N.C.R. = No Calibration Request.

### 4.3. Test Setup

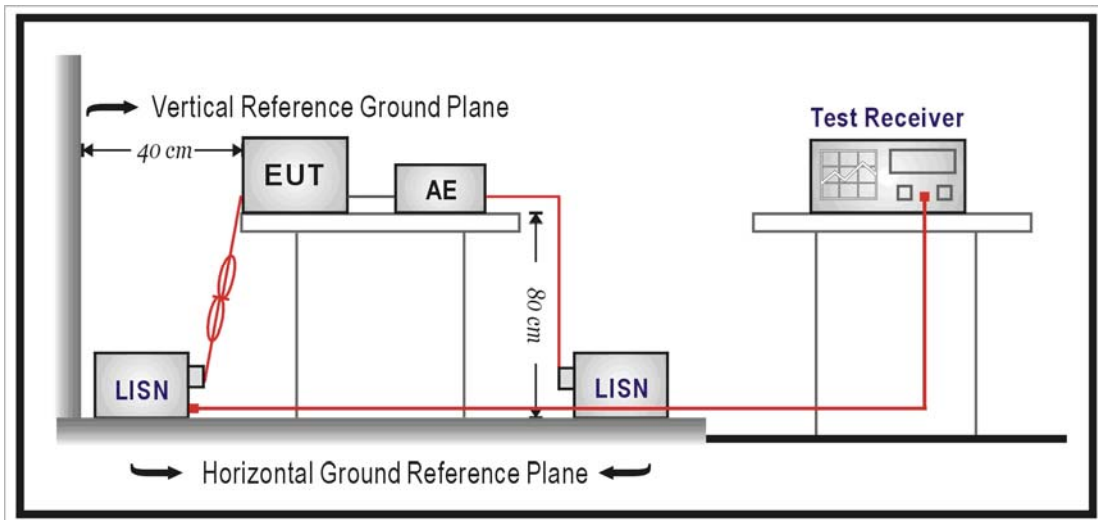

#### 4.4. Test Procedure

The EUT and simulators are connected to the main power through a line impedance stabilization network (L.I.S.N.). This provides a  $50\Omega // 50\mu\text{H}$  coupling impedance for the measuring equipment. The peripheral devices are also connected to the main power through a LISN that provides a  $50\Omega // 50\mu\text{H}$  coupling impedance with 50ohm termination.

Tabletop device shall be placed on a non-conducting platform, of nominal size 1 m by 1.5 m, raised 80 cm above the reference ground plane. The wall of screened room shall be located 40cm to the rear of the EUT. Other surfaces of tabletop or floor standing EUT shall be at least 80cm from any other ground conducting surface including one or more LISNs. For floor-standing device shall be placed under the EUT with a 12mm insulating material.

Conducted emissions were investigated over the frequency range from 0.15 MHz to 30 MHz using a resolution bandwidth of 9 kHz. The equipment under test (EUT) shall be meet the limits in section 4.1.1, as applicable, including the average limit and the quasi-peak limit when using respectively, an average detector and quasi-peak detector measured in accordance with the methods described of related standard. When all of peak value were complied with quasi-peak and average limit from 150kHz to 30MHz then quasi-peak and average measurement was unnecessary.

The AMN shall be placed 0,8 m from the boundary of the unit under test and bonded to a ground reference plane for AMNs mounted on top of the ground reference plane. This distance is between the closest points of the AMN and the EUT. All other units of the EUT and associated equipment shall be at least 0,8 m from the AMN. If the mains power cable is longer than 1m then the cable shall be folded back and forth at the centre of the lead to form a bundle no longer than 0.4m. All of interconnecting cables that hang closer than 40cm to the ground plane shall be folded back and forth in the center forming a bundle 30 cm to 40 cm long. All of EUT and AE shall be separate place more than 0.1m. All  $50\Omega$  ports of the LISN shall be resistively terminated into  $50\Omega$  loads when not connected to the measuring instrument.

If the reading of the measuring receiver shows fluctuations close to the limit, the reading shall be observed for at least 15 s at each measurement frequency; the higher reading shall be recorded with the exception of any brief isolated high reading which shall be ignored.

#### 4.5. Test Result

Standard:	FCC Part 15C	Line:	L1
Test Mode:	Mode 1	Power:	AC 120V/60Hz
		Temp.(°C)/Hum.(%RH):	26(°C)/60%RH
		Date:	05/26/2016
		Test By:	Eric Ou Yang
Description:			

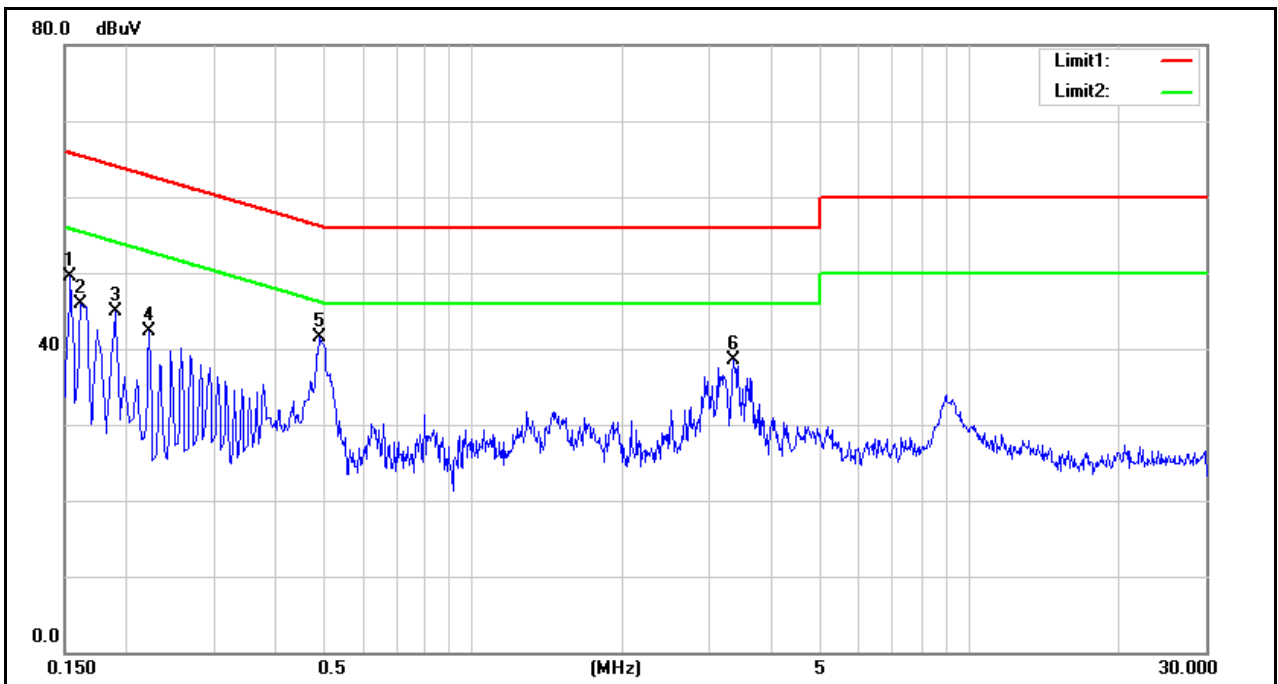

No.	Frequency (MHz)	QP reading (dBuV)	AVG reading (dBuV)	Correction factor (dB)	QP result (dBuV)	AVG result (dBuV)	QP limit (dBuV)	AVG limit (dBuV)	QP margin (dB)	AVG margin (dB)	Remark
1	0.1540	36.28	21.54	9.60	45.88	31.14	65.78	55.78	-19.90	-24.64	Pass
2	0.1620	32.70	18.18	9.60	42.30	27.78	65.36	55.36	-23.06	-27.58	Pass
3	0.1900	29.22	15.16	9.59	38.81	24.75	64.04	54.04	-25.23	-29.29	Pass
4	0.2220	25.20	12.91	9.59	34.79	22.50	62.74	52.74	-27.95	-30.24	Pass
5	0.4900	25.72	20.44	9.61	35.33	30.05	56.17	46.17	-20.84	-16.12	Pass
6	3.3500	24.74	13.66	9.74	34.48	23.40	56.00	46.00	-21.52	-22.60	Pass

Note: 1. Result (dBuV) = Correction factor (dB) + Reading(dBuV).

2. Correction factor (dB) = Cable loss (dB) + L.I.S.N. factor (dB).

Standard:	FCC Part 15C	Line:	N
Test Mode:	Mode 1	Power:	AC 120V/60Hz
		Temp.(°C)/Hum.(%RH):	26(°C)/60%RH
		Date:	05/26/2016
		Test By:	Eric Ou Yang
Description:			

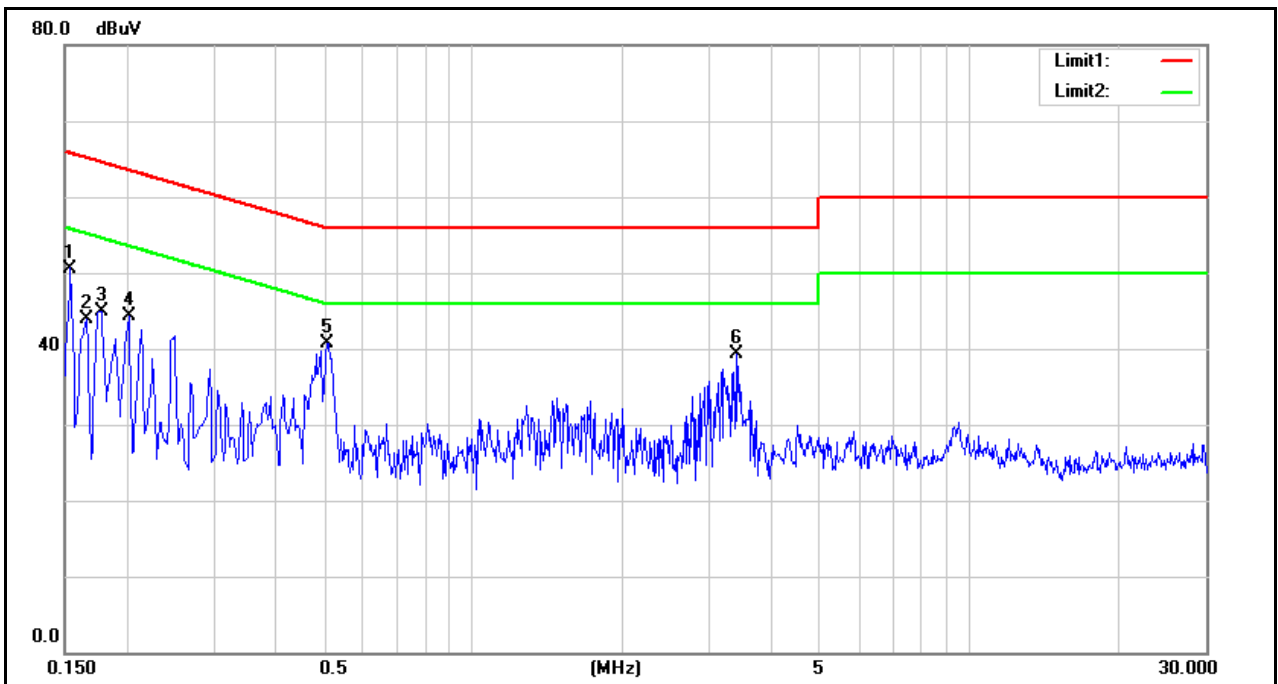

No.	Frequency (MHz)	QP reading (dBuV)	AVG reading (dBuV)	Correction factor (dB)	QP result (dBuV)	AVG result (dBuV)	QP limit (dBuV)	AVG limit (dBuV)	QP margin (dB)	AVG margin (dB)	Remark
1	0.1540	36.65	21.57	9.59	46.24	31.16	65.78	55.78	-19.54	-24.62	Pass
2	0.1660	31.93	18.69	9.59	41.52	28.28	65.16	55.16	-23.64	-26.88	Pass
3	0.1780	31.01	17.11	9.58	40.59	26.69	64.58	54.58	-23.99	-27.89	Pass
4	0.2020	29.06	15.01	9.58	38.64	24.59	63.53	53.53	-24.89	-28.94	Pass
5	0.5100	26.03	20.98	9.60	35.63	30.58	56.00	46.00	-20.37	-15.42	Pass
6	3.3980	23.65	14.05	9.73	33.38	23.78	56.00	46.00	-22.62	-22.22	Pass

Note: 1. Result (dBuV) = Correction factor (dB) + Reading(dBuV).

2. Correction factor (dB) = Cable loss (dB) + L.I.S.N. factor (dB).

## 5 Radiated Emission Measurement

### 5.1. Limit

According to §15.209(a), except as provided elsewhere in this subpart, the emissions from an intentional radiator shall not exceed the field strength levels specified in the following table:

Frequency (MHz)	Field Strength ( $\mu\text{V}/\text{m}$ at meter)	Measurement Distance (meters)
0.009 – 0.490	2400 / F (kHz)	300
0.490 – 1.705	24000 / F (kHz)	30
1.705 – 30.0	30	30
30 - 88	100**	3
88-216	150**	3
216-960	200**	3
Above 960	500	3

\*\* Except as provided in paragraph (g), fundamental emissions from intentional radiators operating under this Section shall not be located in the frequency bands 54-72 MHz, 76-88 MHz, 174-216 MHz or 470-806 MHz. However, operation within these frequency bands is permitted under other sections of this Part, e.g., Sections 15.231 and 15.241.

### 5.2. Test Instruments

3 Meter Chamber (966-A)					
Equipment	Manufacturer	Model Number	Serial Number	Cal. Date	Cal. Period
RF Pre-selector	Agilent	N9039A	MY46520256	01/08/2016	1 year
Spectrum Analyzer	Agilent	E4446A	MY46180578	01/08/2016	1 year
Pre Amplifier	Agilent	8449B	3008A02237	10/07/2015	1 year
Pre Amplifier	Agilent	8447D	2944A11119	01/11/2016	1 year
Broadband Antenna	Schwarzbeck	VULB9168	416	09/25/2015	1 year
Horn Antenna (1~18GHz)	SCHWARZBECK MESS-ELEKTRONIK	BBHA9120D	9120D-550	06/12/2015	1 year
Horn Antenna (18~40GHz)	ETS	3116	86467	09/01/2015	1 year
Loop Antenna	COM-POWER CORPORATION	AL-130	121014	02/01/2016	1 year
Microwave Cable	EMCI	EMC102-KM-KM-14000	151001	10/15/2015	1 year
Microwave Cable	EMCI	EMC-104-SM-SM-14000	140202	10/15/2015	1 year
Microwave Cable	EMCI	EMC104-SM-SM-600	140301	10/15/2015	1 year
Test Site	ATL	TE01	888001	08/27/2015	1 year

Note: N.C.R. = No Calibration Request.

### 5.3. Setup

9kHz ~ 30MHz

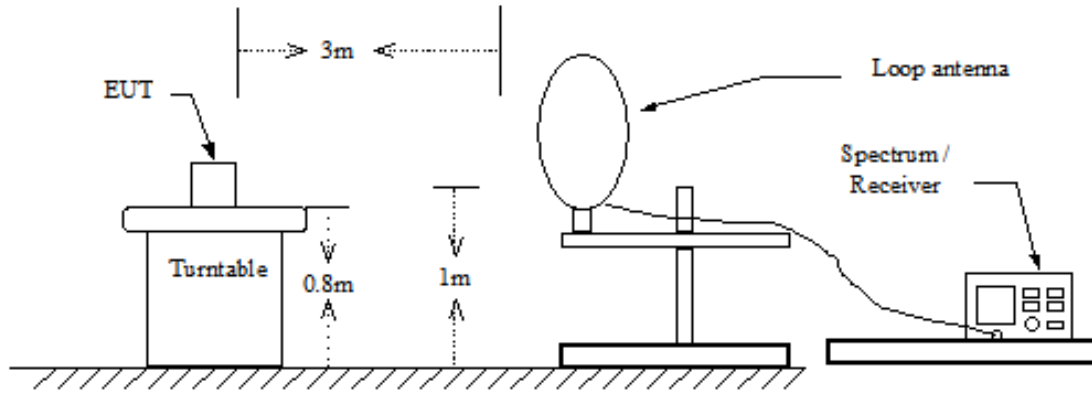

Below 1GHz

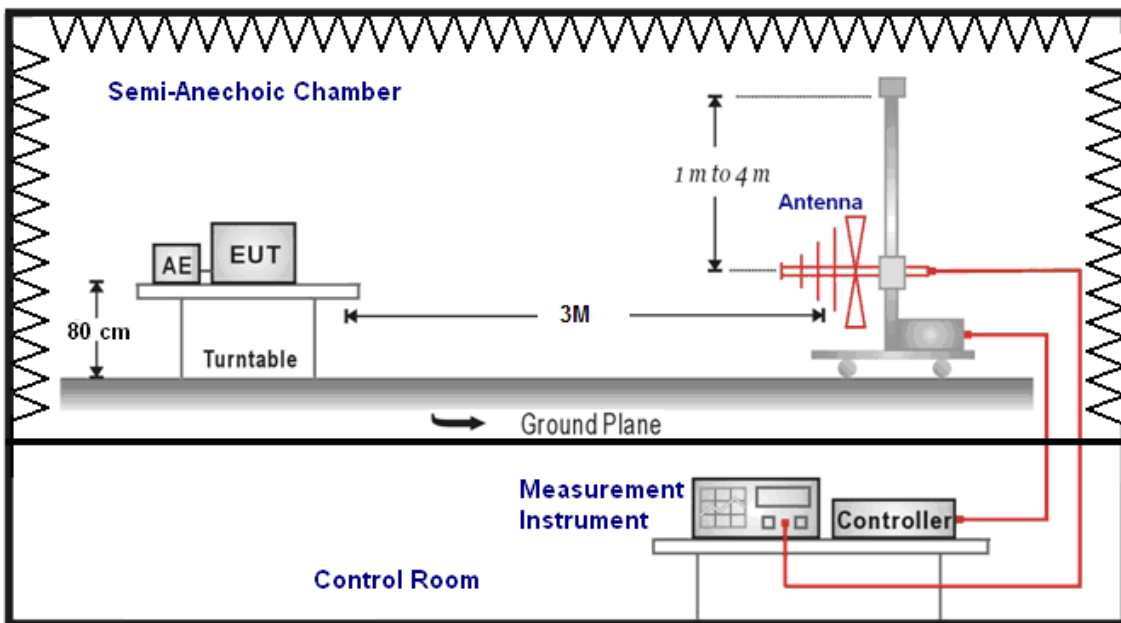



Above 1GHz

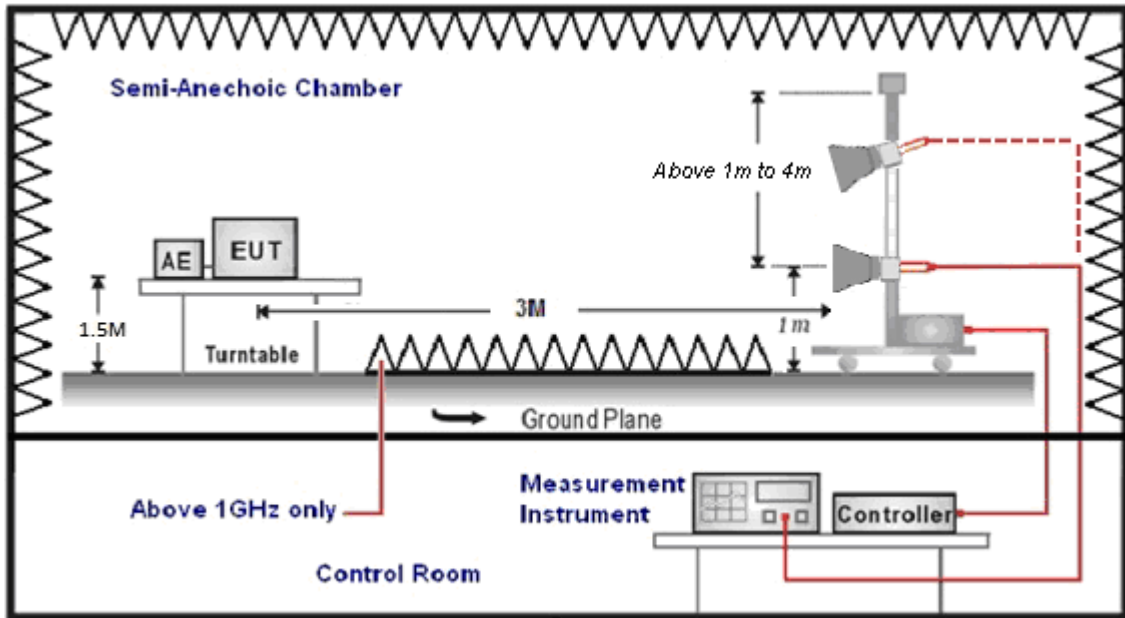

## 5.4. Test Procedure

Final radiation measurements were made on a three-meter, Semi Anechoic Chamber. The EUT system was placed on a nonconductive turntable which is 0.8 or 1.5 meters height (below 1GHz use 0.8m turntable / above 1GHz use 1.5m turntable), top surface 1.0 x 1.5 meter. The spectrum was examined from 250 MHz to 2.5 GHz in order to cover the whole spectrum below 10th harmonic which could generate from the EUT. During the test, EUT was set to transmit continuously & Measurements spectrum range from 9 kHz to 26.5 GHz is investigated.

For measurements below 1 GHz the resolution bandwidth is set to 100 kHz for peak detection measurements or 120 kHz for quasi-peak detection measurements. Peak detection is used unless otherwise noted as quasi-peak.

For measurements above 1 GHz the resolution bandwidth is set to 1 MHz, and then the video bandwidth is set to 1 MHz for peak measurements and 10 Hz for average measurements when Duty cycle >98% / 1/T for average measurements when Duty cycle <98%. A nonconductive material surrounded the EUT to supporting the EUT for standing on three orthogonal planes. At each condition, the EUT was rotated 360 degrees, and the antenna was raised and lowered from one to four meters to find the maximum emission levels. Measurements were taken using both horizontal and vertical antenna polarization.

SCHWARZBECK MESS-ELEKTRONIK Biconilog Antenna at 3 Meter and the SCHWARZBECK Double Ridged Guide Antenna was used in frequencies 1 – 26.5 GHz at a distance of 1 meter. All test results were extrapolated to equivalent signal at 3 meters utilizing an inverse linear distance extrapolation Factor (20dB/decade).

For testing above 1GHz, the emission level of the EUT in peak mode was 20dB lower than average limit (that means the emission level in peak mode also complies with the limit in average mode), then testing will be stopped and peak values of EUT will be reported, otherwise, the emissions will be measured in average mode again and reported.

Appropriate preamplifiers were used for improving sensitivity and precautions were taken to avoid overloading or desensitizing the spectrum analyzer. No post – detector video filters were used in the test.

The spectrum analyzer's 6 dB bandwidth was set to 1 MHz, and the analyzer was operated in the peak detection mode, for frequencies both below and up 1 GHz. The average levels were obtained by subtracting the duty cycle correction factor from the peak readings.

The following procedures were used to convert the emission levels measured in decibels referenced to 1 microvolt (dBuV) into field intensity in micro volts pre meter (uV/m).

The actual field intensity in decibels referenced to 1 microvolt in to field intensity in micro volts per meter (dBuV/m).

The actual field intensity in referenced to 1 microvolt per meter (dBuV/m) is determined by algebraically adding the measured reading in dBuV, the antenna factor (dB), and cable loss (dB) and Subtracting the gain of preamplifier (dB) is auto calculate in spectrum analyzer.

(1)  $\text{Amplitude (dBuV/m)} = \text{FI (dBuV)} + \text{AF (dBuV)} + \text{CL (dBuV)} - \text{Gain (dB)}$

FI= Reading of the field intensity.

AF= Antenna factor.

CL= Cable loss.

P.S Amplitude is auto calculate in spectrum analyzer.

(2)  $\text{Actual Amplitude (dBuV/m)} = \text{Amplitude (dBuV)} - \text{Dis(dB)}$

The FCC specified emission limits were calculated according the EUT operating frequency and by following linear interpolation equations:

(a) For fundamental frequency : Transmitter Output < +30dBm

(b) For spurious frequency : Spurious emission limits = fundamental emission limit /10

Data of measurement within this frequency range without mark in the table above means the reading of emissions are attenuated more than 20dB below the permissible limits or the field strength is too small to be measured.

## 5.5. Test Result

### Below 1GHz

Standard:	FCC Part 15C	Test Distance:	3m
Test Mode:	Mode 1	Power:	AC 120V/60Hz
		Temp.(°C)/Hum.(%RH):	26(°C)/60%RH
		Date:	05/25/2016
		Test By:	Eric Ou Yang

Frequency (MHz)	Reading (dBuV)	Correct Factor (dB/m)	Result (dBuV/m)	Limit (dBuV/m)	Margin (dB)	Remark	Ant.Polar. H / V
269.5000	36.14	-17.08	19.06	46.00	-26.94	QP	H
309.5000	35.53	-15.94	19.59	46.00	-26.41	QP	H
367.0000	32.50	-14.66	17.84	46.00	-28.16	QP	H
632.0000	27.97	-9.61	18.36	46.00	-27.64	QP	H
760.0000	26.83	-7.94	18.89	46.00	-27.11	QP	H
872.0000	27.36	-6.76	20.60	46.00	-25.40	QP	H
121.0000	33.52	-18.06	15.46	43.50	-28.04	QP	V
277.5000	32.48	-16.74	15.74	46.00	-30.26	QP	V
369.0000	33.36	-14.58	18.78	46.00	-27.22	QP	V
602.0000	27.93	-9.95	17.98	46.00	-28.02	QP	V
757.5000	27.20	-7.97	19.23	46.00	-26.77	QP	V
913.0000	26.12	-6.09	20.03	46.00	-25.97	QP	V

Note:1.Result (dBuV) = Correction factor (dB) + Reading(dBuV).

2.Correction factor (dB/m) = Antenna Factor (dB/m) + Cable loss (dB) – Pre-Amplifier gain (dB).

3.No emission found between lowest internal used/generated frequencies to 30MHz (9 kHz~30MHz).

**Above 1GHz**

Standard:		FCC Part 15C		Test Distance:		3m	
Test Mode:		Mode 2		Power:		AC 120V/60Hz	
Frequency:		2402MHz		Temp.(°C)/Hum.(%RH):		26(°C)/60%RH	
				Date:		05/25/2016	
				Test By:		Eric Ou Yang	
Frequency (MHz)	Reading (dBuV)	Correct Factor (dB/m)	Result (dBuV/m)	Limit (dBuV/m)	Margin (dB)	Remark	Ant.Polar. H / V
4804.000	32.44	9.60	42.04	74.00	-31.96	peak	H
4804.000	33.56	9.60	43.16	74.00	-30.84	peak	V

Standard:		FCC Part 15C		Test Distance:		3m	
Test Mode:		Mode 2		Power:		AC 120V/60Hz	
Frequency:		2440MHz		Temp.(°C)/Hum.(%RH):		26(°C)/60%RH	
				Date:		05/25/2016	
				Test By:		Eric Ou Yang	
Frequency (MHz)	Reading (dBuV)	Correct Factor (dB/m)	Result (dBuV/m)	Limit (dBuV/m)	Margin (dB)	Remark	Ant.Polar. H / V
4880.000	32.04	9.72	41.76	74.00	-32.24	peak	H
4880.000	32.11	9.72	41.83	74.00	-32.17	peak	V

Note:1.Result (dBuV) = Correction factor (dB) + Reading(dBuV).

2.Correction factor (dB/m) = Antenna Factor (dB/m) + Cable loss (dB) – Pre-Amplifier gain (dB).

Standard:	FCC Part 15C	Test Distance:	3m				
Test Mode:	Mode 2	Power:	AC 120V/60Hz				
Frequency:	2480MHz	Temp.(°C)/Hum.(%RH):	26(°C)/60%RH				
		Date:	05/25/2016				
		Test By:	Eric Ou Yang				
Frequency (MHz)	Reading (dBuV)	Correct Factor (dB/m)	Result (dBuV/m)	Limit (dBuV/m)	Margin (dB)	Remark	Ant.Polar. H / V
4960.000	32.42	9.85	42.27	74.00	-31.73	peak	H
4960.000	31.01	9.85	40.86	74.00	-33.14	peak	V

Note:1.Result (dBuV) = Correction factor (dB) + Reading(dBuV).

2.Correction factor (dB/m) = Antenna Factor (dB/m) + Cable loss (dB) – Pre-Amplifier gain (dB).

**Band Edge**

Standard:	FCC Part 15C			Test Distance:	3m		
Test Mode:	Mode 2			Power:	AC 120V/60Hz		
Frequency:	2402 MHz			Temp.(°C)/Hum.(%RH):	26(°C)/60%RH		
				Date:	05/25/2016		
				Test By:	Eric Ou Yang		
Frequency (MHz)	Reading (dBuV)	Correct Factor (dB/m)	Result (dBuV/m)	Limit (dBuV/m)	Margin (dB)	Remark	Ant.Polar. H / V
2388.540	44.12	4.88	49.00	74.00	-25.00	peak	H
2390.000	45.38	4.89	50.27	74.00	-23.73	peak	H
2388.100	41.98	4.88	46.86	74.00	-27.14	peak	V
2390.000	39.69	4.89	44.58	74.00	-29.42	peak	V

Standard:	FCC Part 15C			Test Distance:	3m		
Test Mode:	Mode 2			Power:	AC 120V/60Hz		
Frequency:	2480 MHz			Temp.(°C)/Hum.(%RH):	26(°C)/60%RH		
				Date:	05/25/2016		
				Test By:	Eric Ou Yang		
Frequency (MHz)	Reading (dBuV)	Correct Factor (dB/m)	Result (dBuV/m)	Limit (dBuV/m)	Margin (dB)	Remark	Ant.Polar. H / V
2483.500	59.73	5.07	64.80	74.00	-9.20	peak	H
2483.500	34.64	5.07	39.71	54.00	-14.29	AVG	H
2483.620	61.86	5.07	66.93	74.00	-7.07	peak	H
2483.620	34.50	5.07	39.57	54.00	-14.43	AVG	H
2483.500	51.25	5.07	56.32	74.00	-17.68	peak	V
2483.500	31.35	5.07	36.42	54.00	-17.58	AVG	V
2484.040	54.96	5.07	60.03	74.00	-13.97	peak	V
2484.040	30.84	5.07	35.91	54.00	-18.09	AVG	V

Note:1.Result (dBuV) = Correction factor (dB) + Reading(dBuV).

2. Correction factor (dB/m) = Antenna Factor (dB/m) + Cable loss (dB) – Pre-Amplifier gain (dB).

## 6 Maximum Conducted Output Power Measurement

### 6.1. Limit

For systems using digital modulation in the 2400-2483.5MHz, the limit for peak output power is 30dBm.

### 6.2. Test Setup

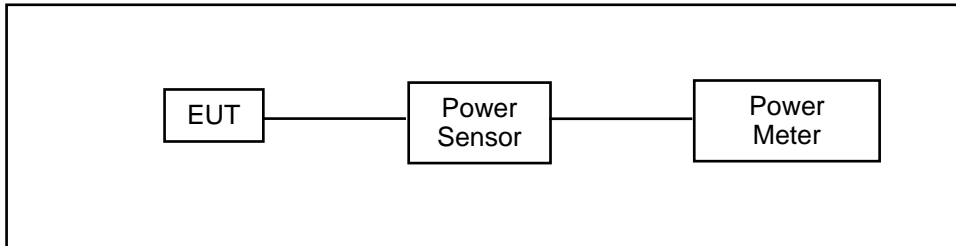

### 6.3. Test Instruments

Equipment	Manufacturer	Model Number	Serial Number	Cal. Date	Remark
Power Sensor	Anritsu	MA2411B	1126022	08/24/2015	1 year
Power Meter	Anritsu	ML2495A	1135009	08/24/2015	1 year
Microwave Cable	EMCI	EMC104-SM-S M-1500	140303	02/23/2016	1 year
Test Site	ATL	TE05	TE05	N.C.R.	-----

Note: N.C.R. = No Calibration Request.

### 6.4. Test Procedure

The tests below are run with the EUT's transmitter set at high power in TX mode. The EUT is needed to force selection of output power level and channel number. While testing, EUT was set to transmit continuously. Remove the Subjective device's antenna and connect the RF output port to power sensor..

### 6.5. Test Result

Frequency (MHz)	Average Power		Peak Power		Limit (dBm)
	(dBm)	(W)	(dBm)	(W)	
2402	6.59	0.00456	7.03	0.00505	< 30
2440	7.10	0.00513	7.62	0.00578	< 30
2480	7.13	0.00516	<b>7.69</b>	<b>0.00587</b>	< 30

Note: The relevant measured result has the offset with cable loss already.



## 7 6dB RF Bandwidth Measurement

### 7.1. Limit

6dB RF Bandwidth: Systems using digital modulation techniques may operate in the 2400–2483.5 MHz bands. The minimum 6 dB band-width shall be at least 500 kHz.

99 % Occupied Bandwidth: N/A

### 7.2. Test Setup

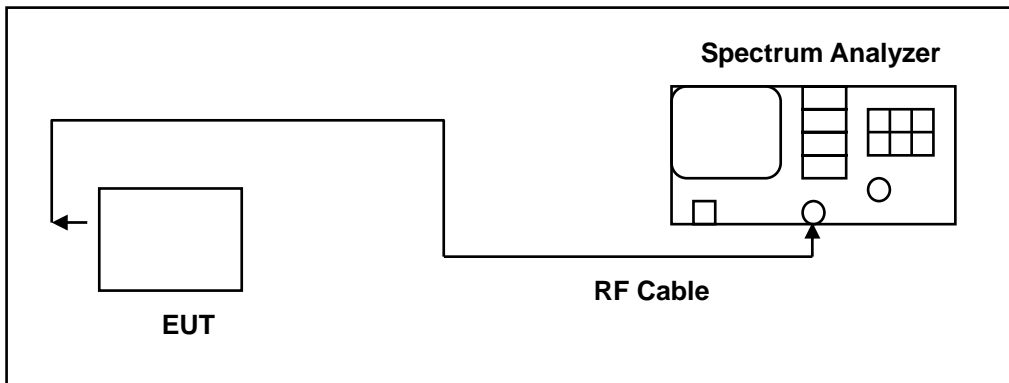

### 7.3. Test Instruments

Equipment	Manufacturer	Model Number	Serial Number	Cal. Date	Remark
Spectrum Analyzer	Agilent	E4445A	MY45300744	12/15/2015	1 year
Microwave Cable	EMCI	EMC104-SM-S M-1500	140303	02/23/2016	1 year
Test Site	ATL	TE05	TE05	N.C.R.	-----

Note: N.C.R. = No Calibration Request.

### 7.4. Test Procedure

The EUT tested to DTS test procedure of KDB558074D01 for compliance to FCC 47CFR 15.247 requirements.

6dB RF Bandwidth: The antenna port of the EUT was connected to the input of a spectrum analyzer. Analyzer RBW was set to 100 kHz. For each RF output channel investigated, the spectrum analyzer center frequency was set to the channel carrier. A peak output reading was taken, a DISPLAY line was drawn 6 dB lower than peak level. The 6 dB bandwidth was determined from where the channel output spectrum intersected the display line.

The test was performed at 3 channels (Channel low, middle, high)

**7.5. Test Result**

Frequency (MHz)	Measurement Results (kHz)	Limit (kHz)
2402	681.100	> 500
2440	687.400	> 500
2480	687.300	> 500

**7.6. Test Graphs**

Mode 2: Bluetooth LE Link Mode	
2402 MHz	<p>Agilent Spectrum Analyzer - Occupied BW</p> <p>Center Freq: 2.402000000 GHz          Trig: Free Run          #Attenu: 10 dB</p> <p>Ref Offset: 0.5 dB          Ref: 15.00 dBm</p> <p>Center: 2.402 GHz          #Res BW: 100 kHz          #VBW: 300 kHz          Span: 3 MHz          Sweep: 1 ms</p> <p>Occupied Bandwidth: 1.0438 MHz          Total Power: 13.4 dBm</p> <p>Transmit Freq Error: 420 Hz          x dB Bandwidth: 681.1 kHz</p> <p>OBW Power: 99.00 %          x dB: -6.00 dB</p> <p>Center Freq: 2.402000000 GHz          CF Step: 300.000 kHz          Freq Offset: 0 Hz</p>
2440 MHz	<p>Agilent Spectrum Analyzer - Occupied BW</p> <p>Center Freq: 2.440000000 GHz          Trig: Free Run          #Attenu: 10 dB</p> <p>Ref Offset: 0.5 dB          Ref: 15.00 dBm</p> <p>Center: 2.44 GHz          #Res BW: 100 kHz          #VBW: 300 kHz          Span: 3 MHz          Sweep: 1 ms</p> <p>Occupied Bandwidth: 1.0435 MHz          Total Power: 14.0 dBm</p> <p>Transmit Freq Error: 547 Hz          x dB Bandwidth: 687.4 kHz</p> <p>OBW Power: 99.00 %          x dB: -6.00 dB</p> <p>Center Freq: 2.440000000 GHz          CF Step: 300.000 kHz          Freq Offset: 0 Hz</p>
2480 MHz	<p>Agilent Spectrum Analyzer - Occupied BW</p> <p>Center Freq: 2.480000000 GHz          Trig: Free Run          #Attenu: 10 dB</p> <p>Ref Offset: 0.5 dB          Ref: 15.00 dBm</p> <p>Center: 2.48 GHz          #Res BW: 100 kHz          #VBW: 300 kHz          Span: 3 MHz          Sweep: 1 ms</p> <p>Occupied Bandwidth: 1.0439 MHz          Total Power: 14.2 dBm</p> <p>Transmit Freq Error: -11.322 kHz          x dB Bandwidth: 687.3 kHz</p> <p>OBW Power: 99.00 %          x dB: -6.00 dB</p> <p>Center Freq: 2.480000000 GHz          CF Step: 300.000 kHz          Freq Offset: 0 Hz</p>

## 8 Maximum Power Density Measurement

### 8.1. Limit

For digitally modulated systems, the power spectral density conducted from the intentional radiator to the antenna shall not be greater than 8 dBm in any 3 kHz band during any time interval of continuous transmission.

### 8.2. Test Setup

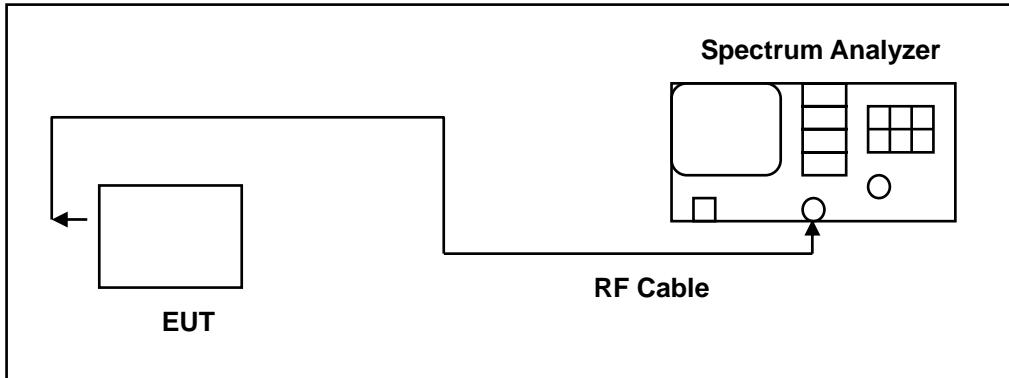

### 8.3. Test Instruments

Equipment	Manufacturer	Model Number	Serial Number	Cal. Date	Remark
Spectrum Analyzer	Agilent	E4445A	MY45300744	12/15/2015	1 year
Microwave Cable	EMCI	EMC104-SM-S M-1500	140303	02/23/2016	1 year
Test Site	ATL	TE05	TE05	N.C.R.	-----

Note: N.C.R. = No Calibration Request.

### 8.4. Test Procedure

The EUT tested to DTS test procedure of KDB558074D01 for compliance to FCC 47CFR 15.247 requirements.

1. Set analyzer center frequency to DTS channel center frequency.
2. Set the span to 1.5 times the DTS bandwidth.
3. Set the RBW to:  $3 \text{ kHz} \leq \text{RBW} \leq 100 \text{ kHz}$ .
4. Set the VBW  $\geq 3 \times \text{RBW}$ .
5. Detector = peak.
6. Sweep time = auto couple.
7. Trace mode = max hold.
8. Allow trace to fully stabilize.
9. Use the peak marker function to determine the maximum amplitude level within the RBW.
10. If measured value exceeds limit, reduce RBW (no less than 3 kHz) and repeat.

**8.5. Test Result**

Frequency (MHz)	Measurement Results (dBm/3KHz)	Limit (dBm)
2402	-8.613	< 8
2440	-7.939	< 8
2480	-7.554	< 8

**8.6. Test Graphs**

Mode 2: Bluetooth LE Link Mode	
2402 MHz	<p>Agilent Spectrum Analyzer - Swept SA</p> <p>PRO: Wide Trg: Free Run Avg Type: Log-Pwr IF Gain: 1.0 Att: 10 dB AvgHold: 100/100</p> <p>Ref Offset 0.5 dB Mkr1 2.401 988 30 GHz Ref 0.00 dBm -6.613 dBm</p> <p>Center 2.402000 GHz Span 2.000 MHz #Res BW 3.0 kHz #VBW 10 kHz Sweep 213.3 ms (40001 pts)</p> <p>Frequency: Auto Tune Center Freq: 2.402000000 GHz Start Freq: 2.401000000 GHz Stop Freq: 2.403000000 GHz CF Step: 200.000 kHz (Auto/Man) Freq Offset: 0 Hz</p>
2440 MHz	<p>Agilent Spectrum Analyzer - Swept SA</p> <p>PRO: Wide Trg: Free Run Avg Type: Log-Pwr IF Gain: 1.0 Att: 10 dB AvgHold: 100/100</p> <p>Ref Offset 0.5 dB Mkr1 2.439 988 35 GHz Ref 0.00 dBm -7.939 dBm</p> <p>Center 2.440000 GHz Span 2.000 MHz #Res BW 3.0 kHz #VBW 10 kHz Sweep 213.3 ms (40001 pts)</p> <p>Frequency: Auto Tune Center Freq: 2.440000000 GHz Start Freq: 2.439000000 GHz Stop Freq: 2.441000000 GHz CF Step: 200.000 kHz (Auto/Man) Freq Offset: 0 Hz</p>
2480 MHz	<p>Agilent Spectrum Analyzer - Swept SA</p> <p>PRO: Wide Trg: Free Run Avg Type: Log-Pwr IF Gain: 1.0 Att: 10 dB AvgHold: 100/100</p> <p>Ref Offset 0.5 dB Mkr1 2.479 988 35 GHz Ref 0.00 dBm -7.554 dBm</p> <p>Center 2.480000 GHz Span 2.000 MHz #Res BW 3.0 kHz #VBW 10 kHz Sweep 213.3 ms (40001 pts)</p> <p>Frequency: Auto Tune Center Freq: 2.480000000 GHz Start Freq: 2.479000000 GHz Stop Freq: 2.481000000 GHz CF Step: 200.000 kHz (Auto/Man) Freq Offset: 0 Hz</p>

## 9 Out of Band Conducted Emissions Measurement

### 9.1. Limit

In any 100 kHz bandwidth outside the frequency band in which the spread spectrum or digitally modulated intentional radiator is operating, the radio frequency power that is produced by the intentional radiator shall be at least 20 dB below that in the 100 kHz bandwidth within the band that contains the highest level of the desired power

### 9.2. Test Setup

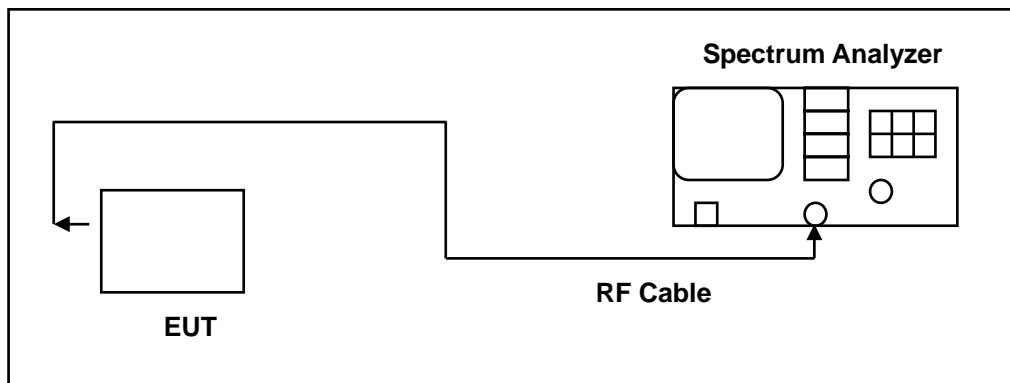

### 9.3. Test Instruments

Equipment	Manufacturer	Model Number	Serial Number	Cal. Date	Remark
Spectrum Analyzer	Agilent	E4445A	MY45300744	12/15/2015	1 year
Spectrum Analyzer	Agilent	E4408B	MY45107753	07/27/2015	1 year
Microwave Cable	EMCI	EMC104-SM-S M-1500	140303	02/23/2016	1 year
Test Site	ATL	TE05	TE05	N.C.R.	-----

Note: N.C.R. = No Calibration Request.

### 9.4. Test Procedure

In any 100 kHz bandwidth outside the EUT pass band, the RF power produced by the modulation products of the spreading sequence, the information sequence, and the carrier frequency shall be at least 20 dB below that of the maximum in-band 100 kHz emission, antenna output of the EUT was coupled directly to spectrum analyzer; if an external attenuator and/or cable was used, these losses are compensated for with the analyzer OFFSET function.

All other types of emissions from the EUT shall meet the general limits for radiated frequencies outside the pass band.

The test was performed at 3 channels.

### 9.5. Test Graphs

#### Reference level

Mode 2: Bluetooth LE Link Mode	
2402 MHz	
2440 MHz	
2480 MHz	



**Out of Band Conducted Emissions**

Mode 2: Bluetooth LE Link Mode

2402 MHz

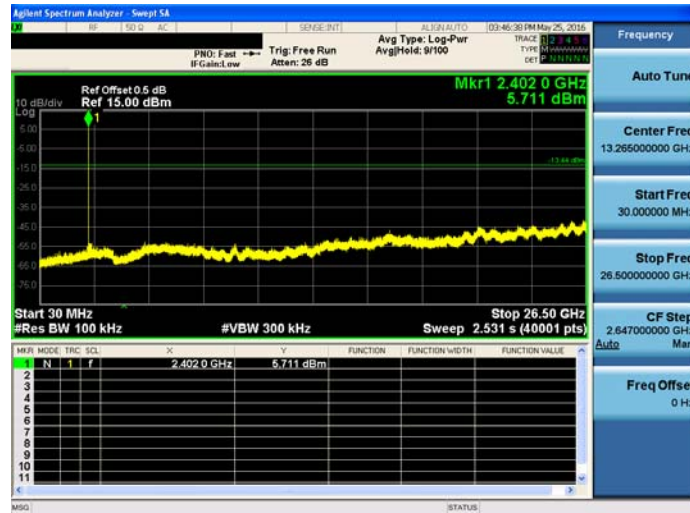

2440 MHz

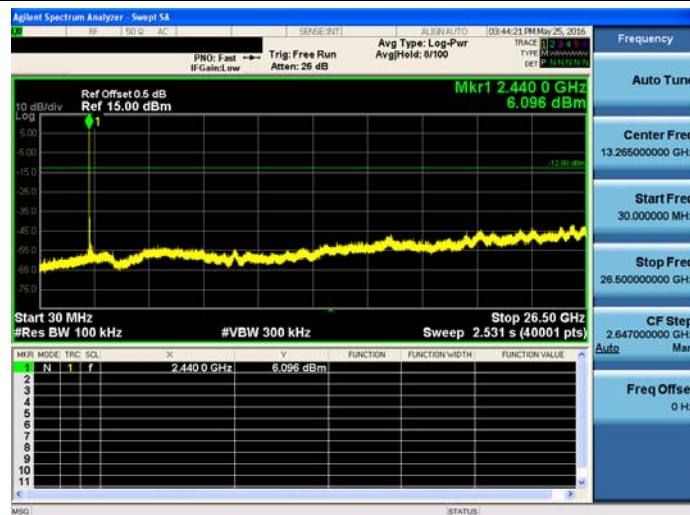

2480 MHz

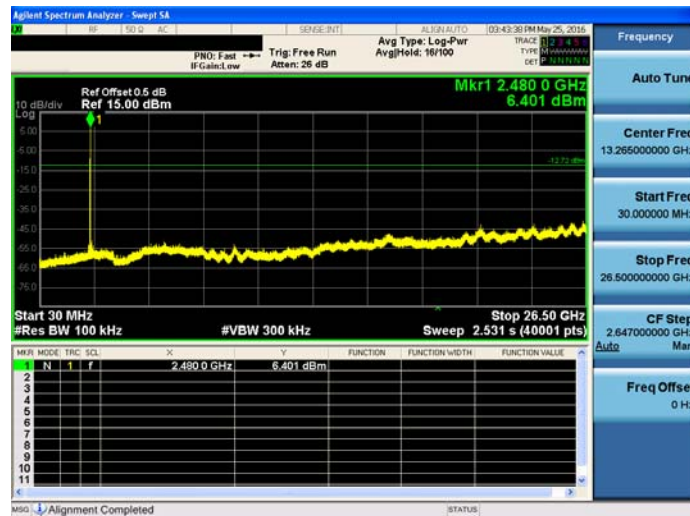

**Conducted Band Edge**

Mode 2: Bluetooth LE Link Mode

2402 MHz

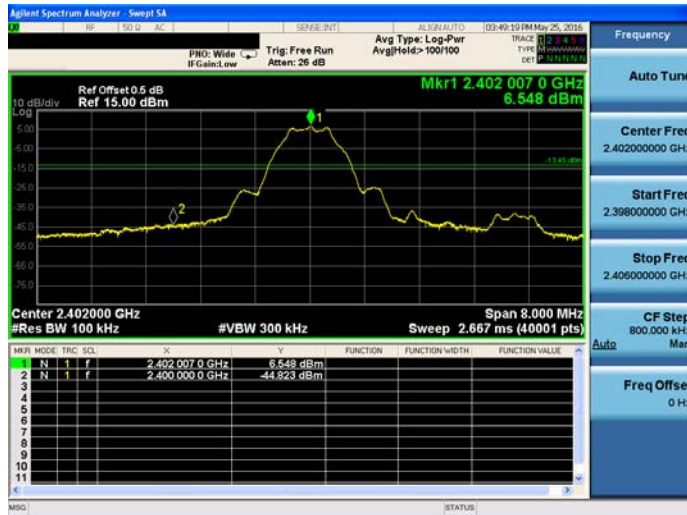

2480 MHz



## **10 Antenna Measurement**

### **10.1.Limit**

For intentional device, according to 15.203, an intentional radiator shall be designed to ensure that no antenna other than that furnished by the responsible party shall be used with the device.

And According to 15.247 (b), if transmitting antennas of directional gain greater than 6 dBi are used, the power shall be reduced by the amount in dB that the directional gain of the antenna exceeds 6dBi.

### **10.2.Antenna Connector Construction**

See section 2 – antenna information.