

Label Location

A	B	C	D
---	---	---	---

1	REVISIONS				1	
	ZONE	REV	DESCRIPTION	APPD		DATE
		X1	FIRST DESIGN			

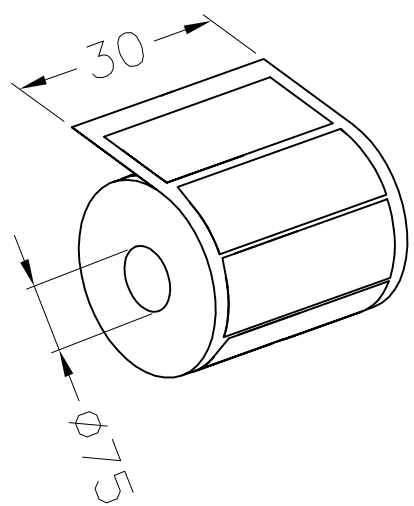
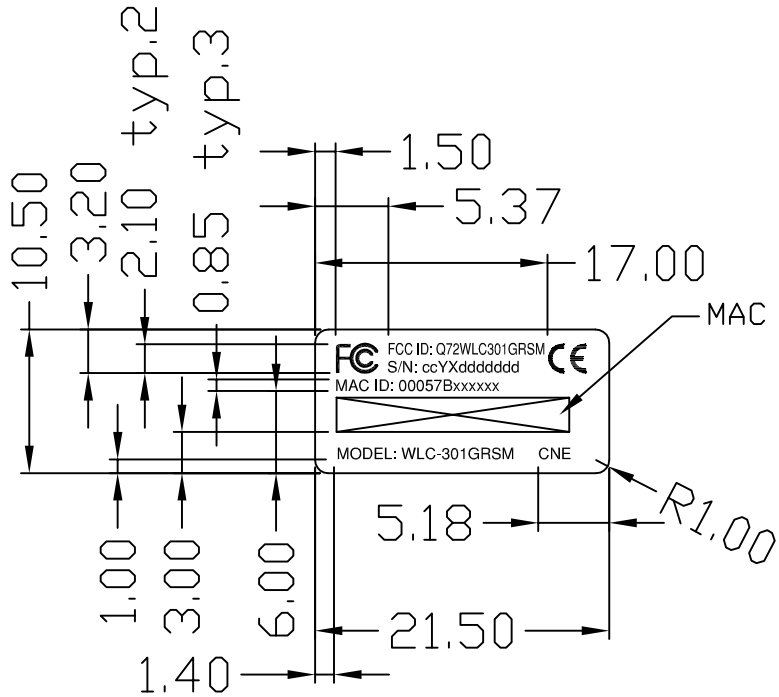
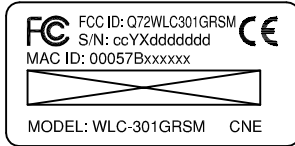

- NOTES:
1. MATERIAL: 0.05mm THICKNESS POLYESTER FILM LABEL(FOR BRADY PRINTER 600).
 2. THE LABEL IS PRINTED BY PRODUCTION.
 3. FINISH: POLISHED.
 4. RIBBON TYPE: IMTL, RIBBON RICOH B110C.
 5. THE PART NEED BE RoHS COMPLIANT.
 6. SUPPLIER LETTER OF SELF-DECLARATION ANF RoHS TESTING REPORT MUST BE PRESENT ALONG WITH FIRST ARTICLE SUBMISSION.

7	TOLERANCES UNLESS OTHERWISE SPECIFIED DIMENSIONS ARE IN MM DECIMALS ANGULAR .X ± 0.25 ± 1 .XX ± 0.13	MODEL NO 470RRAD002RUB00	 CHUNG NAM ELECTRONICS CO., LTD.	QTY
	DO NOT SCALE IF IN DOUBT ASK	PART NO 479K0R00849AARD		
8	WARNING THIS DOCUMENT IS THE PROPERTY OF CHUNG NAM OR ITS CLIENTS AND CONTAINS CONFIDENTIAL AND TRADE SECRET INFORMATION OF CHUNG NAM OR ITS CLIENTS.	CKD	DATE	TITLE Product label, FI25SM, RoHS, @
		APPD	DATE	
		CAD FILENAME Product label-FI25SM-x1.dwg	SCALE 2 : 1	
A	B	C	D	