

Label Location

REVISIONS				
ZONE	REV	DESCRIPTION	APPD	DATE
	A	RELEASE FOR PRODUCTION	XM Zhang	14-Mar-2007
	B	Add FCC logo	XM Zhang	11-Jun-2007

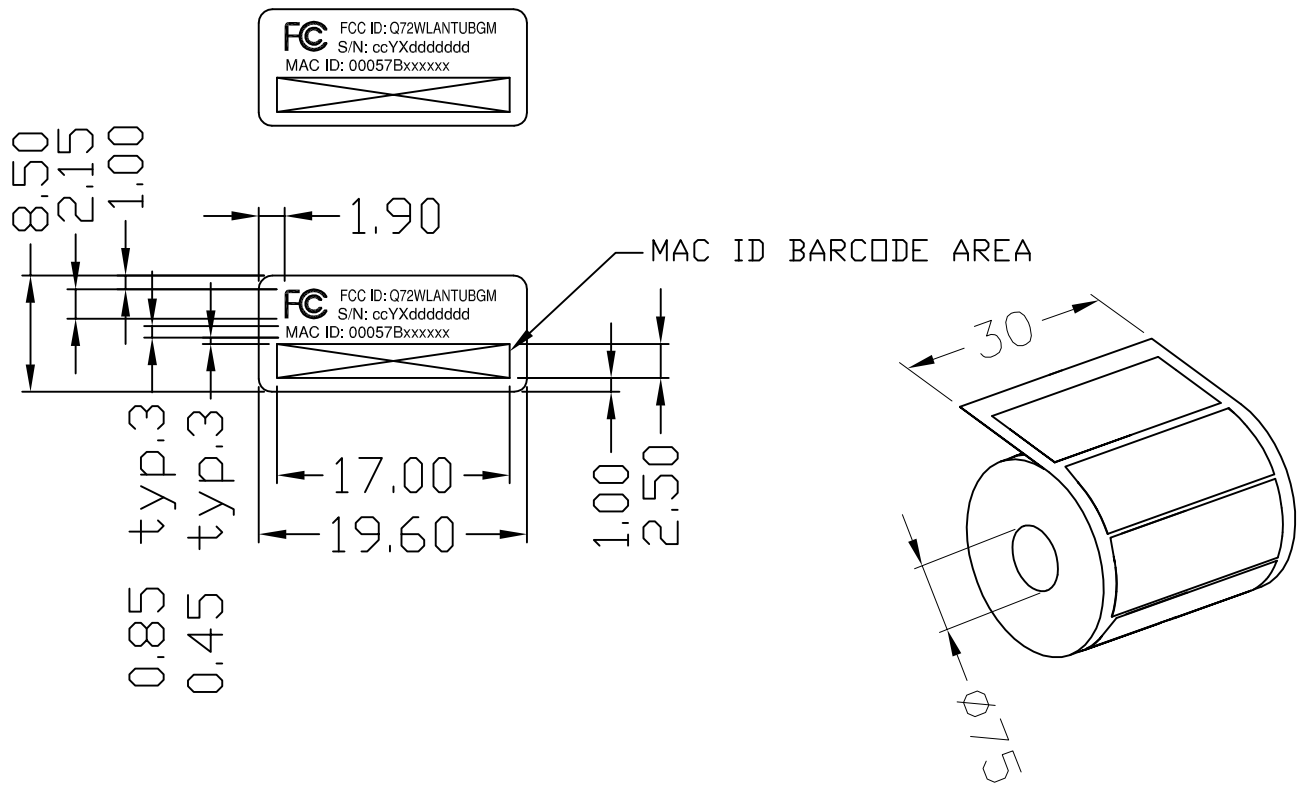

NOTES:

- MATERIAL: 0.05mm THICKNESS POLYESTER FILM LABEL(FOR BRADY PRINTER 600).
- THE LABEL IS PRINTED BY PRODUCTION.
- FINISH: POLISHED.
- RIBBON TYPE: IMTL, RIBBON RICOH B110C, (CNE PART NUMBER: EZDR10013AGEN).
- THE PART NEED BE RoHS COMPLIANT.
- SUPPLIER LETTER OF SELF-DECLARATION ANF RoHS TESTING REPORT MUST BE PRESENT ALONG WITH FIRST ARTICLE SUBMISSION.
- FORMAT NOTES:
 - PN SN: ccYXddddddd
 where cc=Model code, please follow file REMWSL801.
 Y=Year, i.e. 3=Y2003, 4=Y2004
 X=Month, i.e. 1=Jan, A=Oct, B=Nov, C=Dec.
 ddddddd=Product running serial number starting.
 The starting number should follow each model.
 - MAC NO. : 00057Bxxxxxx
 The starting number should follow each model.
 where xxxxxx is hexadecimal digits number.
 The starting number should follow file REMWSL-001.
 - BAR CODE AREA: MINIMUM 17x2.5 mm; CODE 128.

	QTY
--	-----

TOLERANCES
UNLESS OTHERWISE SPECIFIED
DIMENSIONS ARE IN MM
DECIMALS ANGULAR
.X ± 0.25 ± 1
.XX ± 0.13

DO NOT SCALE IF IN DOUBT ASK

MODEL NO ORRAD002AUB00	
PART NO 9KOR00693BARD	
DWN XM Zhang	DATE 9-Feb-2007
CKD	DATE
APPD	DATE
CAD FILENAME MAC LABEL-FI58 PCBA-02.dwg	



CHUNG NAM ELECTRONICS CO., LTD.

TITLE MAC LABEL-FI58 PCBA			
SCALE 2 : 1	DWG NO	SHEET 1 OF 1	REV B

WARNING
THIS DOCUMENT IS THE
PROPERTY OF CHUNG NAM
OR ITS CLIENTS AND CONTAINS
CONFIDENTIAL AND TRADE
SECRET INFORMATION OF
CHUNG NAM OR ITS CLIENTS.