



RADIO TEST REPORT

Test Report No. : 13892671H

Applicant : OMRON HEALTHCARE Co., Ltd.
Type of EUT : DIGITAL THERMOMETER
Model Number of EUT : ET6250
FCC ID : Q6ZMC6810T2
Test regulation : FCC Part 15 Subpart C: 2021
Test Result : Complied (Refer to SECTION 3)

1. This test report shall not be reproduced in full or partial, without the written approval of UL Japan, Inc.
2. The results in this report apply only to the sample tested.
3. This sample tested is in compliance with the limits of the above regulation.
4. The test results in this test report are traceable to the national or international standards.
5. This test report must not be used by the customer to claim product certification, approval, or endorsement by the A2LA accreditation body.
6. This test report covers Radio technical requirements.
It does not cover administrative issues such as Manual or non-Radio test related Requirements. (if applicable)
7. The all test items in this test report are conducted by UL Japan, Inc. Ise EMC Lab.
8. The opinions and the interpretations to the result of the description in this report are outside scopes where UL Japan, Inc. has been accredited.
9. The information provided from the customer for this report is identified in Section 1.

Date of test: August 10 and 11, 2021

Representative test engineer: 
Junya Okuno
Engineer

Approved by: 
Takayuki Shimada
Leader



CERTIFICATE 5107.02

- The testing in which "Non-accreditation" is displayed is outside the accreditation scopes in UL Japan, Inc.
 There is no testing item of "Non-accreditation".

UL Japan, Inc.
Ise EMC Lab.

4383-326 Asama-cho, Ise-shi, Mie-ken 516-0021 JAPAN
Telephone : +81 596 24 8999
Facsimile : +81 596 24 8124

REVISION HISTORY

Original Test Report No.: 13892671H

Revision	Test report No.	Date	Page revised	Contents
- (Original)	13892671H	September 1, 2021	-	-

UL Japan, Inc.

Ise EMC Lab.

4383-326 Asama-cho, Ise-shi, Mie-ken 516-0021 JAPAN

Telephone : +81 596 24 8999

Facsimile : +81 596 24 8124

Reference: Abbreviations (Including words undescribed in this report)

A2LA	The American Association for Laboratory Accreditation	MCS	Modulation and Coding Scheme
AC	Alternating Current	MRA	Mutual Recognition Arrangement
AFH	Adaptive Frequency Hopping	N/A	Not Applicable
AM	Amplitude Modulation	NIST	National Institute of Standards and Technology
Amp, AMP	Amplifier	NS	No signal detect.
ANSI	American National Standards Institute	NSA	Normalized Site Attenuation
Ant, ANT	Antenna	NVLAP	National Voluntary Laboratory Accreditation Program
AP	Access Point	OBW	Occupied Band Width
ASK	Amplitude Shift Keying	OFDM	Orthogonal Frequency Division Multiplexing
Atten., ATT	Attenuator	P/M	Power meter
AV	Average	PCB	Printed Circuit Board
BPSK	Binary Phase-Shift Keying	PER	Packet Error Rate
BR	Bluetooth Basic Rate	PHY	Physical Layer
BT	Bluetooth	PK	Peak
BT LE	Bluetooth Low Energy	PN	Pseudo random Noise
BW	BandWidth	PRBS	Pseudo-Random Bit Sequence
Cal Int	Calibration Interval	PSD	Power Spectral Density
CCK	Complementary Code Keying	QAM	Quadrature Amplitude Modulation
Ch., CH	Channel	QP	Quasi-Peak
CISPR	Comite International Special des Perturbations Radioelectriques	QPSK	Quadri-Phase Shift Keying
CW	Continuous Wave	RBW	Resolution Band Width
DBPSK	Differential BPSK	RDS	Radio Data System
DC	Direct Current	RE	Radio Equipment
D-factor	Distance factor	RF	Radio Frequency
DFS	Dynamic Frequency Selection	RMS	Root Mean Square
DQPSK	Differential QPSK	RSS	Radio Standards Specifications
DSSS	Direct Sequence Spread Spectrum	Rx	Receiving
EDR	Enhanced Data Rate	SA, S/A	Spectrum Analyzer
EIRP, e.i.r.p.	Equivalent Isotropically Radiated Power	SG	Signal Generator
EMC	ElectroMagnetic Compatibility	SVSWR	Site-Voltage Standing Wave Ratio
EMI	ElectroMagnetic Interference	TR	Test Receiver
EN	European Norm	Tx	Transmitting
ERP, e.r.p.	Effective Radiated Power	VBW	Video BandWidth
EU	European Union	Vert.	Vertical
EUT	Equipment Under Test	WLAN	Wireless LAN
Fac.	Factor		
FCC	Federal Communications Commission		
FHSS	Frequency Hopping Spread Spectrum		
FM	Frequency Modulation		
Freq.	Frequency		
FSK	Frequency Shift Keying		
GFSK	Gaussian Frequency-Shift Keying		
GNSS	Global Navigation Satellite System		
GPS	Global Positioning System		
Hori.	Horizontal		
ICES	Interference-Causing Equipment Standard		
IEC	International Electrotechnical Commission		
IEEE	Institute of Electrical and Electronics Engineers		
IF	Intermediate Frequency		
ILAC	International Laboratory Accreditation Conference		
ISED	Innovation, Science and Economic Development Canada		
ISO	International Organization for Standardization		
JAB	Japan Accreditation Board		
LAN	Local Area Network		
LIMS	Laboratory Information Management System		

CONTENTS	PAGE
SECTION 1: Customer information.....	5
SECTION 2: Equipment under test (EUT).....	5
SECTION 3: Test specification, procedures & results.....	6
SECTION 4: Operation of EUT during testing.....	9
SECTION 5: Radiated Spurious Emission	11
SECTION 6: Antenna Terminal Conducted Tests.....	13
APPENDIX 1: Test data	14
99 % Occupied Bandwidth and 6 dB Bandwidth.....	14
Maximum Peak Output Power.....	16
Average Output Power.....	17
Radiated Spurious Emission	19
Conducted Spurious Emission	25
Power Density	28
APPENDIX 2: Test instruments	30
APPENDIX 3: Photographs of test setup	31
Radiated Spurious Emission	31
Worst Case Position.....	32
Antenna Terminal Conducted Tests.....	33

SECTION 1: Customer information

Company Name : OMRON HEALTHCARE Co., Ltd.
Address : 53, Kunotsubo, Terado-cho, Muko, KYOTO, 617-0002 Japan
Telephone Number : +81-75-925-2045
Facsimile Number : +81-75-925-2046
Contact Person : Toshiaki Yuasa

The information provided from the customer is as follows;

- Applicant, Type of EUT, Model Number of EUT, FCC ID on the cover and other relevant pages
 - Operating/Test Mode(s) (Mode(s)) on all the relevant pages
 - SECTION 1: Customer information
 - SECTION 2: Equipment under test (EUT) other than the Receipt Date
 - SECTION 4: Operation of EUT during testing
- * The laboratory is exempted from liability of any test results affected from the above information in SECTION 2 and 4.

SECTION 2: Equipment under test (EUT)

2.1 Identification of EUT

Type : DIGITAL THERMOMETER
Model Number : ET6250
Serial Number : Refer to SECTION 4.2
Rating : DC 3.0 V
Receipt Date : August 10, 2021
Country of Mass-production : China
Condition : Production prototype
(Not for Sale: This sample is equivalent to mass-produced items.)
Modification : No Modification by the test lab.

2.2 Product Description

Model: ET6250 (referred to as the EUT in this report) is a DIGITAL THERMOMETER.

Radio Specification

Radio Type : Transceiver
Frequency of Operation : 2402 MHz - 2480 MHz
Modulation : GFSK
Antenna type : Pattern Antenna
Antenna Gain : -9.49 dBi
Clock frequency (Maximum) : 32 MHz

SECTION 3: Test specification, procedures & results

3.1 Test Specification

Test Specification : FCC Part 15 Subpart C
FCC Part 15 final revised on May 3, 2021 and effective July 2, 2021

Title : FCC 47 CFR Part 15 Radio Frequency Device Subpart C Intentional Radiators
Section 15.207 Conducted limits
Section 15.247 Operation within the bands 902-928 MHz, 2400-2483.5 MHz,
and 5725-5850 MHz

*The customer has declared that the EUT has complies with FCC Part 15 Subpart B as SDoC.

3.2 Procedures and results

Item	Test Procedure	Specification	Worst margin	Results	Remarks
Conducted Emission	FCC: ANSI C63.10-2013 6. Standard test methods ----- ISED: RSS-Gen 8.8	FCC: Section 15.207 ----- ISED: RSS-Gen 8.8	N/A	N/A	*1)
6dB Bandwidth	FCC: KDB 558074 D01 15.247 Meas Guidance v05r02 ----- ISED: -	FCC: Section 15.247(a)(2) ----- ISED: RSS-247 5.2(a)	See data.	Complied a)	Conducted
Maximum Peak Output Power	FCC: KDB 558074 D01 15.247 Meas Guidance v05r02 ----- ISED: RSS-Gen 6.12	FCC: Section 15.247(b)(3) ----- ISED: RSS-247 5.4(d)		Complied b)	Conducted
Power Density	FCC: KDB 558074 D01 15.247 Meas Guidance v05r02 ----- ISED: -	FCC: Section 15.247(e) ----- ISED: RSS-247 5.2(b)		Complied c)	Conducted
Spurious Emission Restricted Band Edges	FCC: KDB 558074 D01 15.247 Meas Guidance v05r02 ----- ISED: RSS-Gen 6.13	FCC: Section 15.247(d) ----- ISED: RSS-247 5.5 RSS-Gen 8.9 RSS-Gen 8.10	18.7 dB 2483.500 MHz, AV, Horizontal	Complied d), e)	Conducted (below 30 MHz)/ Radiated (above 30 MHz) *2)
Note: UL Japan, Inc.'s EMI Work Procedures No. 13-EM-W0420 and 13-EM-W0422. *1) The test is not applicable since the EUT is not the device that is designed to be connected to the public utility (AC) power line. *2) Radiated test was selected over 30 MHz based on section 15.247(d) and KDB 558074 D01 15.247 Meas Guidance v05r02 8.5 and 8.6. a) Refer to APPENDIX 1 (data of 6 dB Bandwidth and 99 % Occupied Bandwidth) b) Refer to APPENDIX 1 (data of Maximum Peak Output Power) c) Refer to APPENDIX 1 (data of Power Density) d) Refer to APPENDIX 1 (data of Conducted Spurious Emission) e) Refer to APPENDIX 1 (data of Radiated Spurious Emission) Symbols: Complied The data of this test item has enough margin, more than the measurement uncertainty. Complied# The data of this test item meets the limits unless the measurement uncertainty is taken into consideration.					

* In case any questions arise about test procedure, ANSI C63.10: 2013 is also referred.

FCC Part 15.31 (e)

The test was performed with the New Battery and the stable voltage was supplied to the EUT RF module during the tests. Therefore, the EUT complies with the requirement.

FCC Part 15.203 Antenna requirement

It is impossible for end users to replace the antenna, because the antenna is mounted inside of the EUT. Therefore, the equipment complies with the antenna requirement of Section 15.203.

UL Japan, Inc.

Ise EMC Lab.

4383-326 Asama-cho, Ise-shi, Mie-ken 516-0021 JAPAN

Telephone : +81 596 24 8999

Facsimile : +81 596 24 8124

3.3 Addition to standard

Item	Test Procedure	Specification	Worst margin	Results	Remarks
99% Occupied Bandwidth	ISED: RSS-Gen 6.7	ISED: -	N/A	-	Conducted

Other than above, no addition, exclusion nor deviation has been made from the standard.

3.4 Uncertainty

There is no applicable rule of uncertainty in this applied standard. Therefore, the results are derived depending on whether or not laboratory uncertainty is applied.

The following uncertainties have been calculated to provide a confidence level of 95 % using a coverage factor $k=2$.

Ise EMC Lab.

Antenna Terminal test

Test Item	Uncertainty (+/-)
20 dB Bandwidth / 99 % Occupied Bandwidth	0.96 %
Maximum Peak Output Power / Average Output Power	1.4 dB
Carrier Frequency Separation	0.42 %
Dwell time / Burst rate	0.10 %
Conducted Spurious Emission	2.6 dB

Radiated emission

Measurement distance	Frequency range	Uncertainty (+/-)
3 m	9 kHz to 30 MHz	3.3 dB
10 m		3.2 dB
3 m	30 MHz to 200 MHz (Horizontal) (Vertical)	4.8 dB
		5.0 dB
	200 MHz to 1000 MHz (Horizontal) (Vertical)	5.2 dB
		6.3 dB
10 m	30 MHz to 200 MHz (Horizontal) (Vertical)	4.8 dB
		4.8 dB
	200 MHz to 1000 MHz (Horizontal) (Vertical)	5.0 dB
		5.0 dB
3 m	1 GHz to 6 GHz	4.9 dB
	6 GHz to 18 GHz	5.2 dB
1 m	10 GHz to 26.5 GHz	5.5 dB
	26.5 GHz to 40 GHz	5.5 dB
10 m	1 GHz to 18 GHz	5.2 dB

3.5 Test Location

UL Japan, Inc. Ise EMC Lab.

*A2LA Certificate Number: 5107.02 / FCC Test Firm Registration Number: 199967

ISED Lab Company Number: 2973C / CAB identifier: JP0002

4383-326 Asama-cho, Ise-shi, Mie-ken 516-0021 JAPAN

Telephone: +81 596 24 8999, Facsimile: +81 596 24 8124

Test site	Width x Depth x Height (m)	Size of reference ground plane (m) / horizontal conducting plane	Other rooms	Maximum measurement distance
No.1 semi-anechoic chamber	19.2 x 11.2 x 7.7	7.0 x 6.0	No.1 Power source room	10 m
No.2 semi-anechoic chamber	7.5 x 5.8 x 5.2	4.0 x 4.0	-	3 m
No.3 semi-anechoic chamber	12.0 x 8.5 x 5.9	6.8 x 5.75	No.3 Preparation room	3 m
No.3 shielded room	4.0 x 6.0 x 2.7	N/A	-	-
No.4 semi-anechoic chamber	12.0 x 8.5 x 5.9	6.8 x 5.75	No.4 Preparation room	3 m
No.4 shielded room	4.0 x 6.0 x 2.7	N/A	-	-
No.5 semi-anechoic chamber	6.0 x 6.0 x 3.9	6.0 x 6.0	-	-
No.5 measurement room	6.4 x 6.4 x 3.0	6.4 x 6.4	-	-
No.6 shielded room	4.0 x 4.5 x 2.7	4.0 x 4.5	-	-
No.6 measurement room	4.75 x 5.4 x 3.0	4.75 x 4.15	-	-
No.7 shielded room	4.7 x 7.5 x 2.7	4.7 x 7.5	-	-
No.8 measurement room	3.1 x 5.0 x 2.7	3.1 x 5.0	-	-
No.9 measurement room	8.8 x 4.6 x 2.8	2.4 x 2.4	-	-
No.10 shielded room	3.8 x 2.8 x 2.8	3.8 x 2.8	-	-
No.11 measurement room	4.0 x 3.4 x 2.5	N/A	-	-
No.12 measurement room	2.6 x 3.4 x 2.5	N/A	-	-

* Size of vertical conducting plane (for Conducted Emission test) : 2.0 x 2.0 m for No.1, No.2, No.3, and No.4 semi-anechoic chambers and No.3 and No.4 shielded rooms.

3.6 Test data, Test instruments, and Test set up

Refer to APPENDIX.

SECTION 4: Operation of EUT during testing

4.1 Operating Mode(s)

Mode	Remarks*
Bluetooth Low Energy (BT LE)	Payload: PRBS9 Uncoded 1M-PHY
<p>*Power of the EUT was set by the software as follows;</p> <ul style="list-style-type: none"> - Power settings: 0dBm - Software^{*1)}: <Radiated emission test> prod_test (Radiated TxMode 2402) for Low CH test prod_test (Radiated TxMode 2440) for Mid CH test prod_test (Radiated TxMode 2480) for High CH test <p><Antenna Terminal Conducted test> OPM_Communication_Tool.exe Version 1.0.0.0</p> <p>(Date: 2019/09/25, Storage location: Driven by connected PC)</p> <p>*This setting of software is the worst case. Any conditions under the normal use do not exceed the condition of setting. In addition, end users cannot change the settings of the output power of the product.</p>	

*1) There is no difference in RF characteristics for each software.

*The details of Operating mode(s)

Test Item	Operating Mode	Tested frequency
6dB Bandwidth and 99% Occupied Bandwidth	Tx BT LE	2402 MHz
Maximum Peak Output Power		2440 MHz
Spurious Emission (Radiated / Conducted)		2480 MHz
Power Density		

4.2 Configuration and peripherals

[Radiated Emission test]

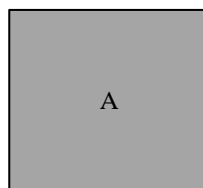

* Setup was taken into consideration and test data was taken under worse case conditions.

Description of EUT

No.	Item	Model number	Serial number	Manufacturer	Remarks
A	DIGITAL THERMOMETER	ET6250	ES1-202107190 *1) ES1-202107191 *2) ES1-202107192 *3)	OMRON HEALTHCARE Co., Ltd.	EUT

*1) Used for Low CH test

*2) Used for Mid CH test

*3) Used for High CH test

UL Japan, Inc.

Ise EMC Lab.

4383-326 Asama-cho, Ise-shi, Mie-ken 516-0021 JAPAN

Telephone : +81 596 24 8999

Facsimile : +81 596 24 8124

[Antenna Terminal Conducted test]

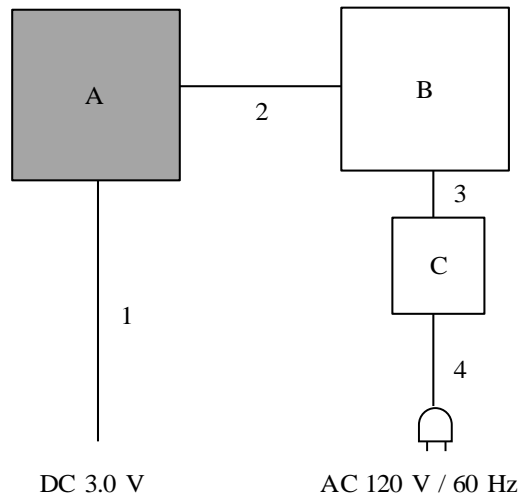

* Cabling and setup(s) were taken into consideration and test data was taken under worse case conditions.

Description of EUT and Support equipment

No.	Item	Model number	Serial number	Manufacturer	Remarks
A	DIGITAL THERMOMETER	ET6250	ES1-202107189	OMRON HEALTHCARE Co., Ltd.	EUT
B	Laptop PC	P24T	4S7GLT2	DELL	-
C	AC Adapter	LA45NM140	0KXTTW	DELL	-

List of cables used

No.	Name	Length (m)	Shield		Remarks
			Cable	Connector	
1	DC Cable	0.5	Unshielded	Unshielded	-
2	USB Cable	1.1	Shielded	Shielded	-
3	DC Cable	1.8	Unshielded	Unshielded	-
4	AC Cable	0.3	Unshielded	Unshielded	-

UL Japan, Inc.

Ise EMC Lab.

4383-326 Asama-cho, Ise-shi, Mie-ken 516-0021 JAPAN

Telephone : +81 596 24 8999

Facsimile : +81 596 24 8124

SECTION 5: Radiated Spurious Emission

Test Procedure

It was measured based on "8.5 and 8.6 of KDB 558074 D01 15.247 Meas Guidance v05r02".

[For below 1 GHz]

EUT was placed on a urethane platform of nominal size, 0.5 m by 1.0 m, raised 0.8 m above the conducting ground plane. The Radiated Electric Field Strength has been measured in a Semi Anechoic Chamber with a ground plane.

[For above 1 GHz]

EUT was placed on a urethane platform of nominal size, 0.5 m by 0.5 m, raised 1.5 m above the conducting ground plane. The Radiated Electric Field Strength has been measured in a Semi Anechoic Chamber with absorbent materials lined on a ground plane.

The height of the measuring antenna varied between 1 m and 4 m and EUT was rotated a full revolution in order to obtain the maximum value of the electric field strength.

Test antenna was aimed at the EUT for receiving the maximum signal and always kept within the illumination area of the 3 dB beamwidth of the antenna.

The measurements were performed for both vertical and horizontal antenna polarization with the Test Receiver, or the Spectrum Analyzer.

The measurements were made with the following detector function of the test receiver and the Spectrum analyzer (in linear mode).

The test was made with the detector (RBW/VBW) in the following table.

When using Spectrum analyzer, the test was made with adjusting span to zero by using peak hold.

Test Antennas are used as below;

Frequency	30 MHz to 200 MHz	200 MHz to 1 GHz	Above 1 GHz
Antenna Type	Biconical	Logperiodic	Horn

In any 100 kHz bandwidth outside the restricted band in which the spread spectrum intentional radiator is operating, the radio frequency power that is produced by the intentional radiator confirmed 20 dB below that in the 100 kHz bandwidth within the band that contains the highest level of the desired power, based on a radiated measurement.

20 dBc was applied to the frequency over the limit of FCC 15.209 / Table 4 of RSS-Gen 8.9(ISED) and outside the restricted band of FCC15.205 / Table 6 of RSS-Gen 8.10 (ISED).

Frequency	Below 1 GHz	Above 1 GHz		20 dBc
Instrument used	Test Receiver	Spectrum Analyzer		Spectrum Analyzer
Detector	QP	PK	AV *1)	PK
IF Bandwidth	BW 120 kHz	RBW: 1 MHz VBW: 3 MHz	<u>11.12.2.5.1</u> RBW: 1 MHz VBW: 3 MHz Detector: Power Averaging (RMS) Trace: 100 traces <u>11.12.2.5.2</u> The duty cycle was less than 98% for detected noise, a duty factor was added to the 11.12.2.5.1 results.	RBW: 100 kHz VBW: 300 kHz

*1) Average Power Measurement was performed based on ANSI C63.10-2013.

UL Japan, Inc.

Ise EMC Lab.

4383-326 Asama-cho, Ise-shi, Mie-ken 516-0021 JAPAN

Telephone : +81 596 24 8999

Facsimile : +81 596 24 8124

Figure 2: Test Setup

Below 1 GHz

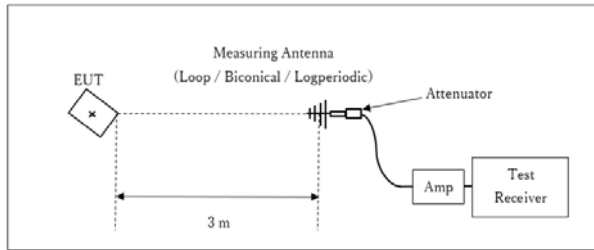

× : Center of turn table

Test Distance: 3 m

1 GHz - 10 GHz

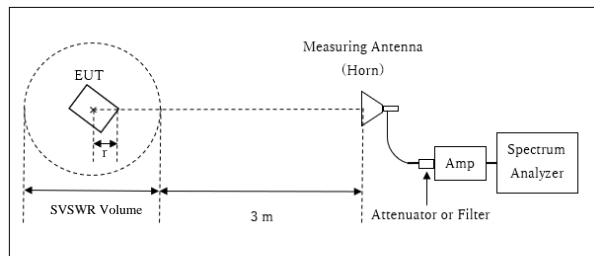

r : Radius of an outer periphery of EUT

× : Center of turn table

Distance Factor: $20 \times \log(3.7 \text{ m} / 3.0 \text{ m}) = 1.83 \text{ dB}$

* Test Distance: $(3 + \text{SVSWR Volume} / 2) - r = 3.70 \text{ m}$

SVSWR Volume : 1.5 m

(SVSWR Volume has been calibrated based on CISPR 16-1-4.)

r = 0.05 m

10 GHz - 26.5 GHz

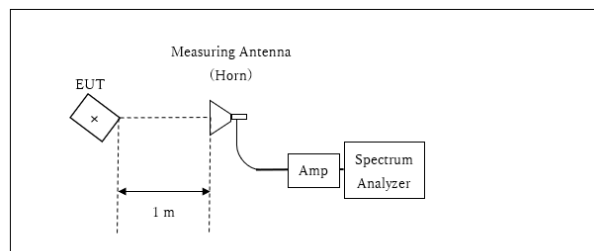

× : Center of turn table

Distance Factor: $20 \times \log(1.0 \text{ m} / 3.0 \text{ m}) = -9.5 \text{ dB}$

*Test Distance: 1 m

- The carrier level and noise levels were confirmed at each position of X, Y and Z axes of EUT to see the position of maximum noise, and the test was made at the position that has the maximum noise.

The test results and limit are rounded off to one decimal place, so some differences might be observed.

Measurement range : 30 MHz - 26.5 GHz

Test data : APPENDIX

Test result : Pass

UL Japan, Inc.

Ise EMC Lab.

4383-326 Asama-cho, Ise-shi, Mie-ken 516-0021 JAPAN

Telephone : +81 596 24 8999

Facsimile : +81 596 24 8124

SECTION 6: Antenna Terminal Conducted Tests

Test Procedure

The tests were made with below setting connected to the antenna port.

Test	Span	RBW	VBW	Sweep time	Detector	Trace	Instrument used
6dB Bandwidth	3 MHz	100 kHz	300 kHz	Auto	Peak	Max Hold	Spectrum Analyzer
99% Occupied Bandwidth *1)	Enough width to display emission skirts	1 to 5 % of OBW	Three times of RBW	Auto	Peak	Max Hold	Spectrum Analyzer
Maximum Peak Output Power	-	-	-	Auto	Peak/Average *2)	-	Power Meter (Sensor: 50 MHz BW)
Peak Power Density	1.5 times the 6dB Bandwidth	3 kHz	10 kHz	Auto	Peak	Max Hold	Spectrum Analyzer *3)
Conducted Spurious Emission *4) *5)	9kHz to 150kHz	200 Hz	620 Hz	Auto	Peak	Max Hold	Spectrum Analyzer
	150kHz to 30MHz	9.1 kHz	27 kHz				

*1) Peak hold was applied as Worst-case measurement.
*2) Reference data
*3) Section 11.10.2 Method PKPSD (peak PSD) of "ANSI C63.10-2013".
*4) In the frequency range below 30MHz, RBW was narrowed to separate the noise contents. Then, wide-band noise near the limit was checked separately, however the noise was low enough as shown in the chart. (9 kHz - 150 kHz: RBW = 200 Hz, 150 kHz - 30 MHz: RBW = 9.1 kHz).
*5) The limits in CFR 47, Part 15, Subpart C, paragraph 15.209(a), are identical to those in RSS-Gen section 8.9, Table 6, since the measurements are performed in terms of magnetic field strength and converted to electric field strength levels (as reported in the table) using the free space impedance of 377 Ohms. For example, the measurement at frequency 9 kHz resulted in a level of 45.5 dBuV/m, which is equivalent to $45.5 - 51.5 = -6.0$ dBuA/m, which has the same margin, 3 dB, to the corresponding RSS-Gen Table 6 limit as it has to 15.209(a) limit.

The test results and limit are rounded off to two decimals place, so some differences might be observed.
The equipment and cables were not used for factor 0 dB of the data sheets.

Test data : APPENDIX
Test result : Pass

APPENDIX 1: Test data

99 % Occupied Bandwidth and 6 dB Bandwidth

Report No. 13892671H
Test place Ise EMC Lab. No.6 Measurement Room
Date August 11, 2021
Temperature / Humidity 23 deg. C / 60 % RH
Engineer Junya Okuno
Mode Tx BT LE

Mode	Frequency [MHz]	99 % Occupied Bandwidth [kHz]	6 dB Bandwidth [MHz]	Limit for 6 dB Bandwidth [MHz]
BT LE	2402	1057.2	0.669	> 0.5000
	2440	1056.7	0.676	> 0.5000
	2480	1059.7	0.700	> 0.5000

99 % Occupied Bandwidth and 6 dB Bandwidth

BT LE

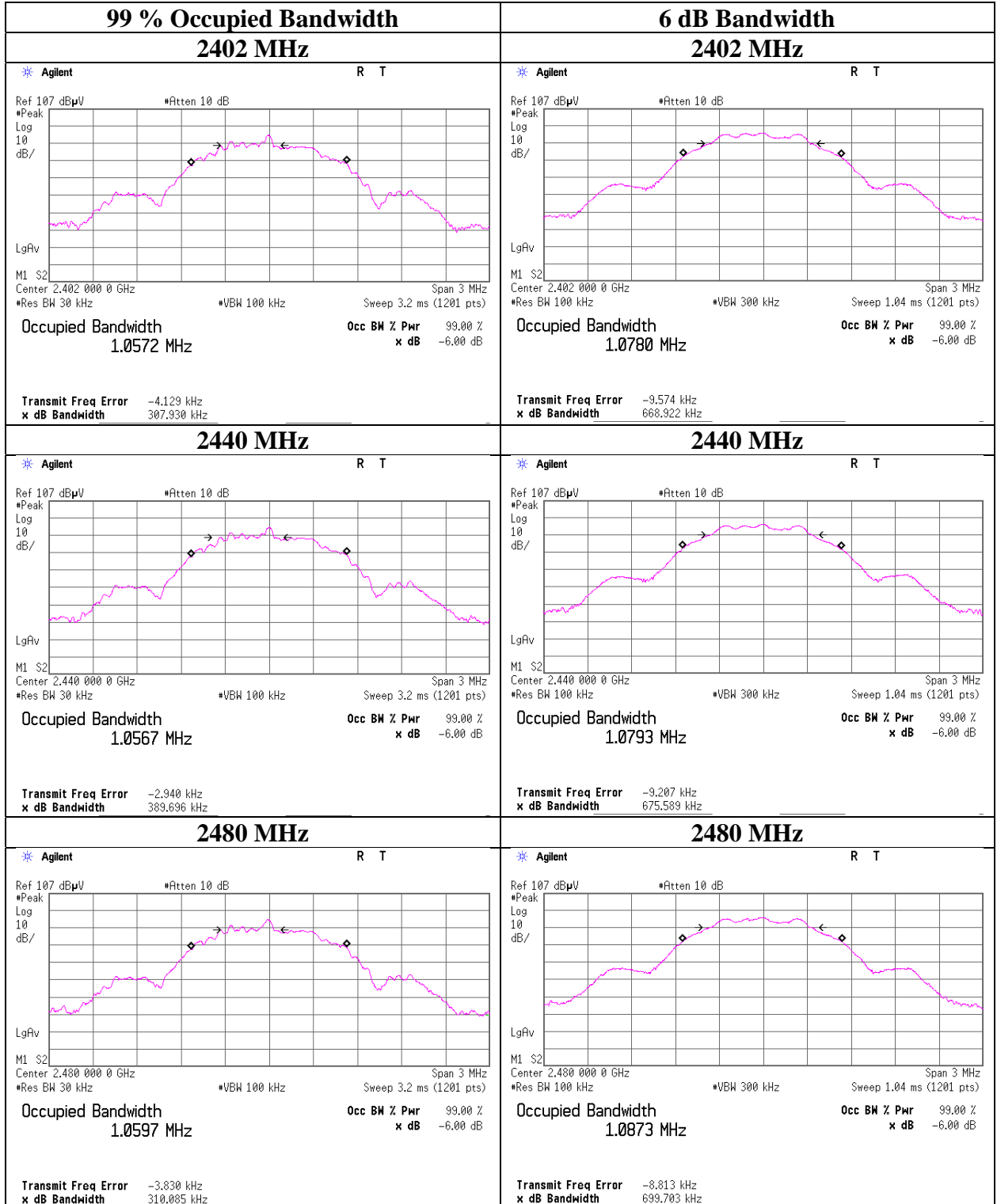

Maximum Peak Output Power

Report No. 13892671H
 Test place Ise EMC Lab. No.6 Measurement Room
 Date August 11, 2021
 Temperature / Humidity 23 deg. C / 60 % RH
 Engineer Junya Okuno
 Mode Tx BT LE

Freq. [MHz]	Reading [dBm]	Cable Loss [dB]	Atten. Loss [dB]	Conducted Power					e.i.r.p. for RSS-247					
				Result		Limit		Margin [dB]	Antenna Gain [dBi]	Result		Limit		Margin [dB]
				[dBm]	[mW]	[dBm]	[mW]			[dBm]	[mW]	[dBm]	[mW]	
2402	-13.44	1.46	10.02	-1.96	0.64	30.00	1000	31.96	-9.49	-11.45	0.07	36.02	4000	47.47
2440	-13.47	1.47	10.02	-1.98	0.63	30.00	1000	31.98	-9.49	-11.47	0.07	36.02	4000	47.49
2480	-13.53	1.48	10.02	-2.03	0.63	30.00	1000	32.03	-9.49	-11.52	0.07	36.02	4000	47.54

Sample Calculation:

Result = Reading + Cable Loss (including the cable(s) customer supplied) + Attenuator Loss
 e.i.r.p. Result = Conducted Power Result + Antenna Gain

UL Japan, Inc.

Ise EMC Lab.

4383-326 Asama-cho, Ise-shi, Mie-ken 516-0021 JAPAN

Telephone : +81 596 24 8999

Facsimile : +81 596 24 8124

Average Output Power
(Reference data for RF Exposure)

Report No. 13892671H
Test place Ise EMC Lab. No.6 Measurement Room
Date August 11, 2021
Temperature / Humidity 23 deg. C / 60 % RH
Engineer Junya Okuno
Mode Tx BT LE

BT LE

Freq. [MHz]	Reading [dBm]	Cable Loss [dB]	Atten. Loss [dB]	Result (Time average)		Duty factor [dB]	Result (Burst power average)	
				[dBm]	[mW]		[dBm]	[mW]
2402	-15.94	1.46	10.02	-4.46	0.36	1.68	-2.78	0.53
2440	-15.97	1.47	10.02	-4.48	0.36	1.68	-2.80	0.52
2480	-16.04	1.48	10.02	-4.54	0.35	1.68	-2.86	0.52

Sample Calculation:

Result (Time average) = Reading + Cable Loss (including the cable(s) customer supplied) + Attenuator Loss

Result (Burst power average) = Time average + Duty factor

Burst rate confirmation

Report No. 13892671H
Test place Ise EMC Lab. No.2 Measurement Room
Date August 10, 2021
Temperature / Humidity 23 deg. C / 57 % RH
Engineer Takafumi Noguchi
Mode Tx BT LE

BT LE

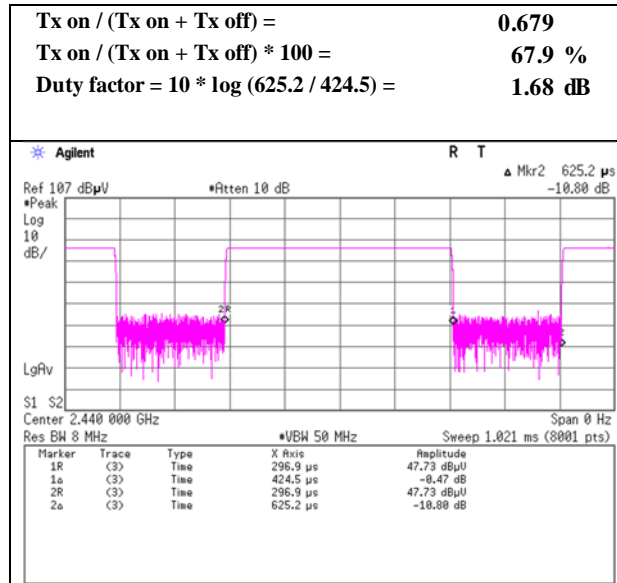

* Since the burst rate is not different between the channels, the data has been obtained on the representative channel.

Radiated Spurious Emission

Report No. 13892671H
Test place Ise EMC Lab.
Semi Anechoic Chamber No.2
Date August 10, 2021
Temperature / Humidity 23 deg. C / 57 % RH
Engineer Takafumi Noguchi
Mode Tx BT LE 2402 MHz

Polarity	Frequency [MHz]	Detector	Reading [dBuV]	Ant.Fac. [dB/m]	Loss [dB]	Gain [dB]	Duty Factor [dB]	Result [dBuV/m]	Limit [dBuV/m]	Margin [dB]	Remark
Hori.	42.242	QP	22.0	11.0	6.9	28.5	-	11.4	40.0	28.6	
Hori.	93.233	QP	22.8	9.5	7.4	28.3	-	11.4	43.5	32.1	
Hori.	160.957	QP	21.9	12.6	7.9	28.1	-	14.3	43.5	29.2	
Hori.	305.728	QP	20.8	13.4	8.9	27.7	-	15.4	46.0	30.6	
Hori.	587.699	QP	21.7	18.5	10.1	29.2	-	21.1	46.0	24.9	
Hori.	794.490	QP	21.7	20.5	11.0	29.0	-	24.1	46.0	21.9	
Hori.	2390.000	PK	46.0	27.6	4.9	34.6	-	44.0	73.9	29.9	
Hori.	4804.000	PK	41.5	31.6	7.1	33.7	-	46.5	73.9	27.5	Floor noise
Hori.	7206.000	PK	42.0	35.8	8.3	33.6	-	52.6	73.9	21.3	Floor noise
Hori.	9608.000	PK	42.3	38.6	9.0	34.2	-	55.7	73.9	18.2	Floor noise
Hori.	2390.000	AV	35.3	27.6	4.9	34.6	1.7	34.9	53.9	19.0	*1)
Hori.	4804.000	AV	33.5	31.6	7.1	33.7	-	38.5	53.9	15.5	Floor noise
Hori.	7206.000	AV	33.6	35.8	8.3	33.6	-	44.2	53.9	9.7	Floor noise
Hori.	9608.000	AV	34.1	38.6	9.0	34.2	-	47.5	53.9	6.4	Floor noise
Vert.	42.242	QP	22.4	11.0	6.9	28.5	-	11.8	40.0	28.2	
Vert.	93.233	QP	23.6	9.5	7.4	28.3	-	12.2	43.5	31.3	
Vert.	160.957	QP	21.7	12.6	7.9	28.1	-	14.1	43.5	29.4	
Vert.	305.728	QP	20.6	13.4	8.9	27.7	-	15.2	46.0	30.8	
Vert.	587.699	QP	21.7	18.5	10.1	29.2	-	21.1	46.0	24.9	
Vert.	794.490	QP	21.8	20.5	11.0	29.0	-	24.2	46.0	21.8	
Vert.	2390.000	PK	46.0	27.6	4.9	34.6	-	44.0	73.9	30.0	
Vert.	4804.000	PK	41.6	31.6	7.1	33.7	-	46.6	73.9	27.4	Floor noise
Vert.	7206.000	PK	42.1	35.8	8.3	33.6	-	52.7	73.9	21.2	Floor noise
Vert.	9608.000	PK	42.6	38.6	9.0	34.2	-	56.0	73.9	17.9	Floor noise
Vert.	2390.000	AV	35.3	27.6	4.9	34.6	1.7	34.9	53.9	19.0	*1)
Vert.	4804.000	AV	33.8	31.6	7.1	33.7	-	38.8	53.9	15.2	Floor noise
Vert.	7206.000	AV	33.6	35.8	8.3	33.6	-	44.2	53.9	9.7	Floor noise
Vert.	9608.000	AV	34.3	38.6	9.0	34.2	-	47.8	53.9	6.1	Floor noise

Result = Reading + Ant Factor + Loss (Cable+Attenuator+Filter+Distance factor(above 1 GHz)) - Gain(Amplifier) + Duty factor

*Other frequency noises omitted in this report were not seen or had enough margin (more than 20 dB).

Distance factor: 1 GHz - 10 GHz $20\log(3.7\text{ m} / 3.0\text{ m}) = 1.83\text{ dB}$

10 GHz - 26.5 GHz $20\log(1.0\text{ m} / 3.0\text{ m}) = -9.5\text{ dB}$

*1) Not Out of Band emission(Leakage Power)

20dBc Data Sheet

Polarity	Frequency [MHz]	Detector	Reading [dBuV]	Ant Factor [dB/m]	Loss [dB]	Gain [dB]	Result [dBuV/m]	Limit [dBuV/m]	Margin [dB]	Remark
Hori.	2402.000	PK	88.8	27.5	4.9	34.6	86.7	-	-	Carrier
Hori.	2400.000	PK	44.7	27.6	4.9	34.6	42.6	66.7	24.1	
Vert.	2402.000	PK	86.8	27.5	4.9	34.6	84.7	-	-	Carrier
Vert.	2400.000	PK	44.6	27.6	4.9	34.6	42.5	64.7	22.2	

Result = Reading + Ant Factor + Loss (Cable+Attenuator+Filter+Distance factor(above 1 GHz)) - Gain(Amplifier)

UL Japan, Inc.

Ise EMC Lab.

4383-326 Asama-cho, Ise-shi, Mie-ken 516-0021 JAPAN

Telephone : +81 596 24 8999

Facsimile : +81 596 24 8124

Radiated Spurious Emission
(Reference Plot for band-edge)

Report No. 13892671H
Test place Ise EMC Lab.
Semi Anechoic Chamber No.2
Date August 10, 2021
Temperature / Humidity 23 deg. C / 57 % RH
Engineer Takafumi Noguchi
Mode Tx BT LE 2402 MHz

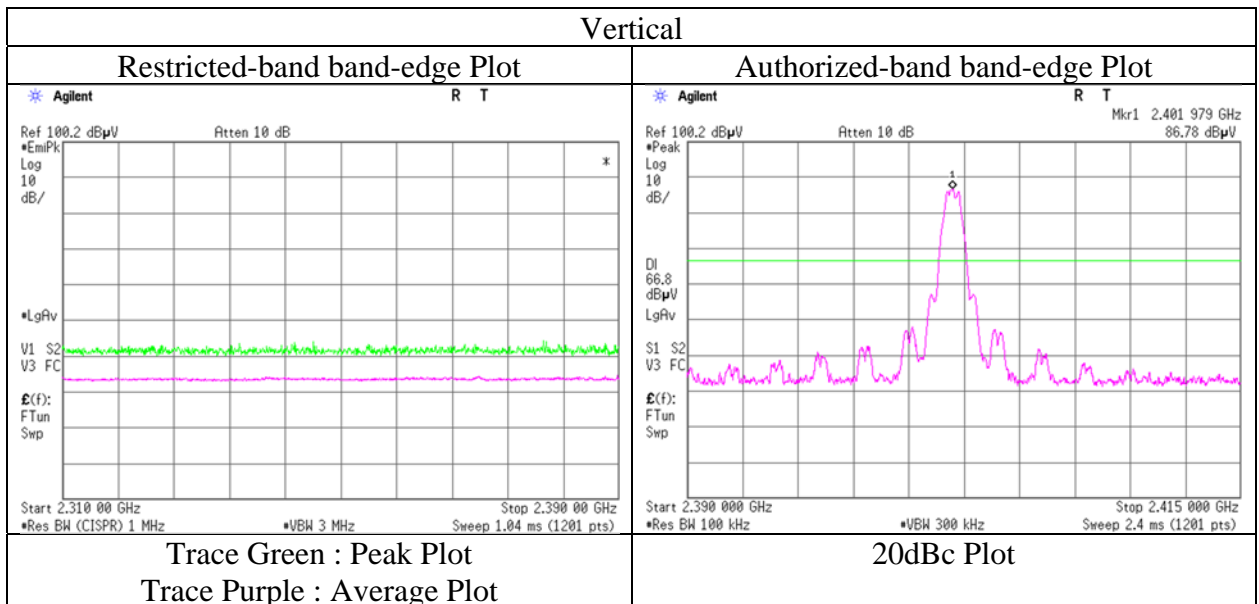
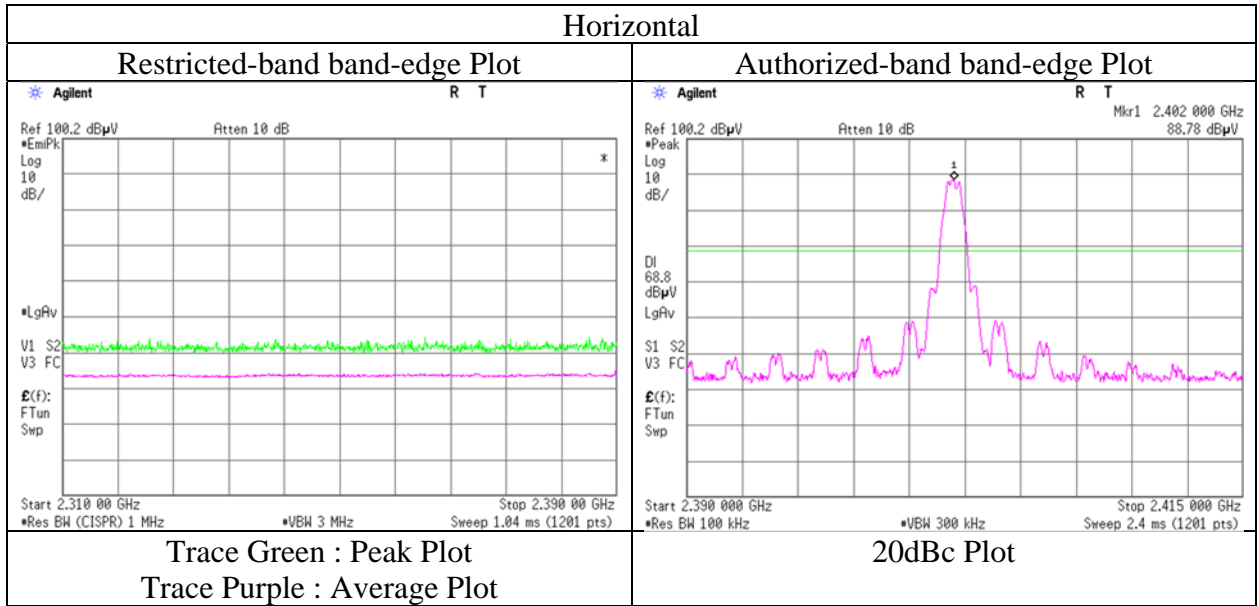

* The measurement was conducted for a sufficiently long enough time to detect any possible spurious emissions. Final result of restricted band edge was shown in tabular data.

Radiated Spurious Emission

Report No. 13892671H
Test place Ise EMC Lab.
Semi Anechoic Chamber No.2
Date August 10, 2021
Temperature / Humidity 23 deg. C / 57 % RH
Engineer Takafumi Noguchi
Mode Tx BT LE 2440 MHz

Polarity	Frequency [MHz]	Detector	Reading [dBuV]	Ant.Fac. [dB/m]	Loss [dB]	Gain [dB]	Duty Factor [dB]	Result [dBuV/m]	Limit [dBuV/m]	Margin [dB]	Remark
Hori.	41.243	QP	21.9	11.2	6.9	28.5	-	11.5	40.0	28.5	
Hori.	92.591	QP	22.4	9.5	7.4	28.3	-	11.0	43.5	32.5	
Hori.	151.319	QP	21.6	12.3	7.9	28.2	-	13.6	43.5	29.9	
Hori.	350.789	QP	20.9	15.0	9.2	27.9	-	17.2	46.0	28.8	
Hori.	494.350	QP	21.6	17.2	9.8	29.0	-	19.6	46.0	26.4	
Hori.	771.719	QP	21.7	20.6	10.9	29.1	-	24.1	46.0	21.9	
Hori.	4880.000	PK	41.6	31.6	7.1	33.8	-	46.5	73.9	27.4	Floor noise
Hori.	7320.000	PK	42.4	36.2	8.4	33.6	-	53.3	73.9	20.6	Floor noise
Hori.	9760.000	PK	42.1	38.8	9.1	34.2	-	55.8	73.9	18.1	Floor noise
Hori.	4880.000	AV	33.7	31.6	7.1	33.8	-	38.6	53.9	15.3	Floor noise
Hori.	7320.000	AV	33.5	36.2	8.4	33.6	-	44.5	53.9	9.5	Floor noise
Hori.	9760.000	AV	33.6	38.8	9.1	34.2	-	47.3	53.9	6.6	Floor noise
Vert.	41.243	QP	22.3	11.2	6.9	28.5	-	11.9	40.0	28.1	
Vert.	92.591	QP	23.6	9.5	7.4	28.3	-	12.2	43.5	31.3	
Vert.	151.319	QP	21.7	12.3	7.9	28.2	-	13.7	43.5	29.8	
Vert.	350.789	QP	20.8	15.0	9.2	27.9	-	17.1	46.0	28.9	
Vert.	494.350	QP	21.4	17.2	9.8	29.0	-	19.4	46.0	26.7	
Vert.	771.719	QP	21.9	20.6	10.9	29.1	-	24.3	46.0	21.7	
Vert.	4880.000	PK	41.7	31.6	7.1	33.8	-	46.6	73.9	27.3	Floor noise
Vert.	7320.000	PK	42.1	36.2	8.4	33.6	-	53.1	73.9	20.9	Floor noise
Vert.	9760.000	PK	42.4	38.8	9.1	34.2	-	56.1	73.9	17.8	Floor noise
Vert.	4880.000	AV	33.5	31.6	7.1	33.8	-	38.5	53.9	15.5	Floor noise
Vert.	7320.000	AV	33.7	36.2	8.4	33.6	-	44.6	53.9	9.3	Floor noise
Vert.	9760.000	AV	33.8	38.8	9.1	34.2	-	47.5	53.9	6.4	Floor noise

Result = Reading + Ant Factor + Loss (Cable+Attenuator+Filter+Distance factor(above 1 GHz)) - Gain(Amplifier)

*Other frequency noises omitted in this report were not seen or had enough margin (more than 20 dB).

Distance factor: 1 GHz - 10 GHz 20log (3.7 m / 3.0 m) = 1.83 dB
10 GHz - 26.5 GHz 20log (1.0 m / 3.0 m) = -9.5 dB

Radiated Spurious Emission

Report No. 13892671H
Test place Ise EMC Lab.
Semi Anechoic Chamber No.2
Date August 10, 2021
Temperature / Humidity 23 deg. C / 57 % RH
Engineer Takafumi Noguchi
Mode Tx BT LE 2480 MHz

Polarity	Frequency [MHz]	Detector	Reading [dBuV]	Ant.Fac. [dB/m]	Loss [dB]	Gain [dB]	Duty Factor [dB]	Result [dBuV/m]	Limit [dBuV/m]	Margin [dB]	Remark
Hori.	41.633	QP	22.0	11.1	6.9	28.5	-	11.5	40.0	28.5	
Hori.	91.774	QP	22.3	9.5	7.4	28.3	-	10.9	43.5	32.7	
Hori.	166.170	QP	21.5	12.8	8.0	28.1	-	14.2	43.5	29.3	
Hori.	312.243	QP	20.8	13.5	8.9	27.7	-	15.5	46.0	30.5	
Hori.	491.797	QP	21.7	17.2	9.8	29.0	-	19.7	46.0	26.4	
Hori.	807.620	QP	21.6	20.6	11.0	29.0	-	24.2	46.0	21.8	
Hori.	2483.500	PK	47.2	27.4	5.0	34.6	-	45.0	73.9	28.9	
Hori.	4960.000	PK	41.5	31.6	7.2	33.8	-	46.4	73.9	27.5	Floor noise
Hori.	7440.000	PK	42.3	36.0	8.4	33.7	-	53.1	73.9	20.8	Floor noise
Hori.	9920.000	PK	42.5	38.9	9.2	34.3	-	56.4	73.9	17.6	Floor noise
Hori.	2483.500	AV	35.7	27.4	5.0	34.6	1.7	35.2	53.9	18.7	*1)
Hori.	4960.000	AV	33.6	31.6	7.2	33.8	-	38.5	53.9	15.4	Floor noise
Hori.	7440.000	AV	33.7	36.0	8.4	33.7	-	44.5	53.9	9.4	Floor noise
Hori.	9920.000	AV	33.8	38.9	9.2	34.3	-	47.6	53.9	6.3	Floor noise
Vert.	41.633	QP	22.2	11.1	6.9	28.5	-	11.7	40.0	28.3	
Vert.	91.774	QP	23.5	9.5	7.4	28.3	-	12.1	43.5	31.5	
Vert.	166.170	QP	21.5	12.8	8.0	28.1	-	14.2	43.5	29.3	
Vert.	312.243	QP	20.8	13.5	8.9	27.7	-	15.5	46.0	30.5	
Vert.	491.797	QP	21.7	17.2	9.8	29.0	-	19.6	46.0	26.4	
Vert.	807.620	QP	21.6	20.6	11.0	29.0	-	24.3	46.0	21.7	
Vert.	2483.500	PK	45.4	27.4	5.0	34.6	-	43.2	73.9	30.7	
Vert.	4960.000	PK	41.3	31.6	7.2	33.8	-	46.2	73.9	27.7	Floor noise
Vert.	7440.000	PK	42.3	36.0	8.4	33.7	-	53.1	73.9	20.8	Floor noise
Vert.	9920.000	PK	42.5	38.9	9.2	34.3	-	56.3	73.9	17.6	Floor noise
Vert.	2483.500	AV	35.5	27.4	5.0	34.6	1.7	35.0	53.9	18.9	*1)
Vert.	4960.000	AV	33.6	31.6	7.2	33.8	-	38.5	53.9	15.4	Floor noise
Vert.	7440.000	AV	33.7	36.0	8.4	33.7	-	44.5	53.9	9.4	Floor noise
Vert.	9920.000	AV	33.9	38.9	9.2	34.3	-	47.8	53.9	6.2	Floor noise

Result = Reading + Ant Factor + Loss (Cable+Attenuator+Filter+Distance factor(above 1 GHz)) - Gain(Amplifier) + Duty factor

*Other frequency noises omitted in this report were not seen or had enough margin (more than 20 dB).

Distance factor: 1 GHz - 10 GHz $20\log(3.7\text{ m} / 3.0\text{ m}) = 1.83\text{ dB}$

10 GHz - 26.5 GHz $20\log(1.0\text{ m} / 3.0\text{ m}) = -9.5\text{ dB}$

*1) Not Out of Band emission(Leakage Power)

Radiated Spurious Emission
(Reference Plot for band-edge)

Report No. 13892671H
Test place Ise EMC Lab.
Semi Anechoic Chamber No.2
Date August 10, 2021
Temperature / Humidity 23 deg. C / 57 % RH
Engineer Takafumi Noguchi
Mode Tx BT LE 2480 MHz

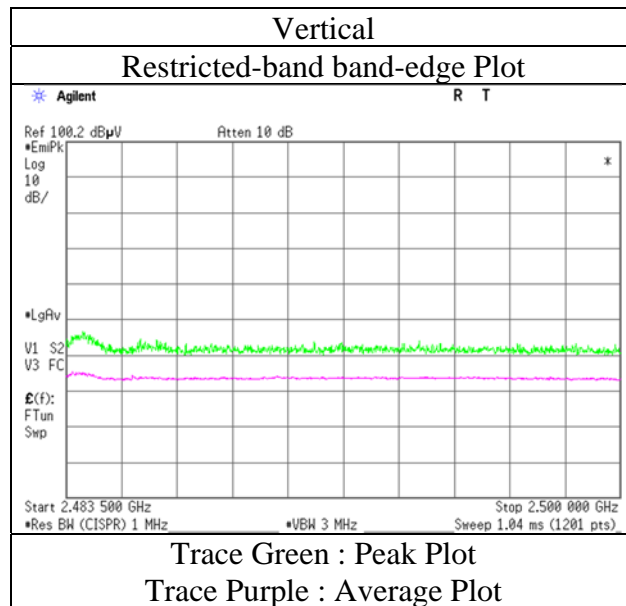
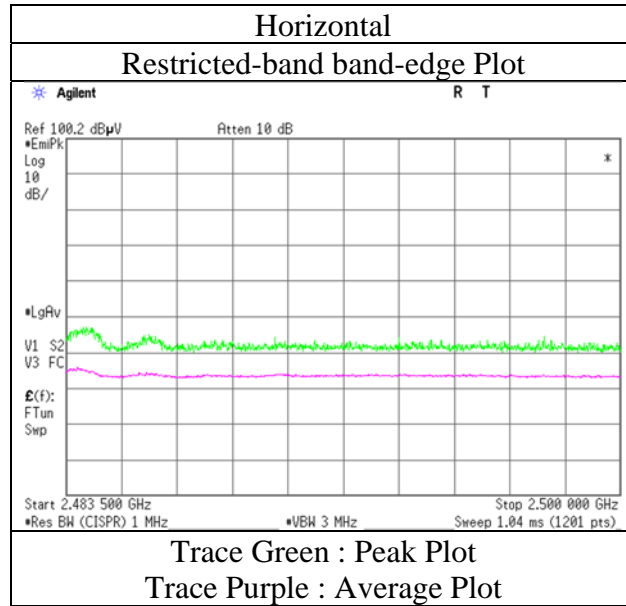

* The measurement was conducted for a sufficiently long enough time to detect any possible spurious emissions. Final result of restricted band edge was shown in tabular data.

Radiated Spurious Emission
(Plot data, Worst case)

Report No.	13892671H
Test place	Ise EMC Lab.
Semi Anechoic Chamber	No.2
Date	August 10, 2021
Temperature / Humidity	23 deg. C / 57 % RH
Engineer	Takafumi Noguchi
Mode	Tx BT LE 2402 MHz

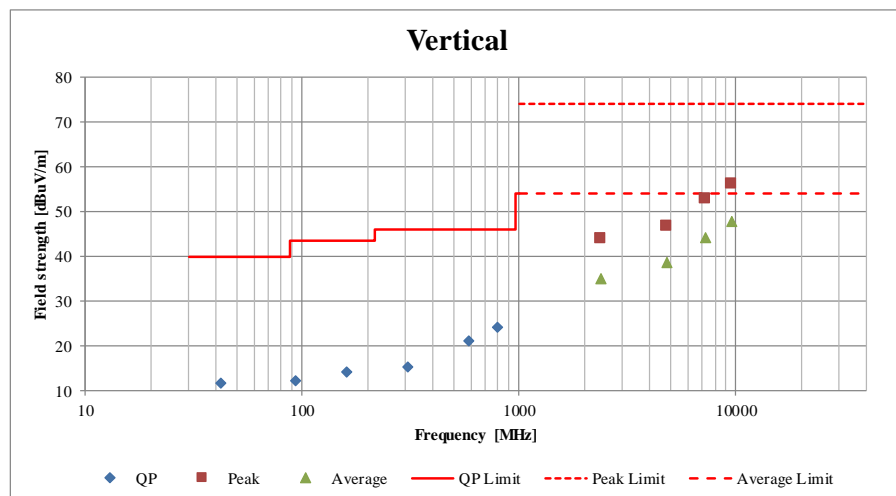
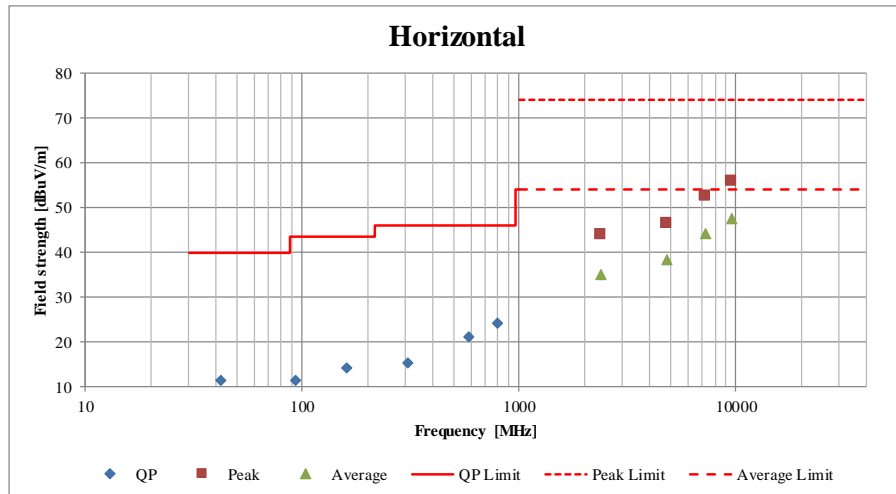

*These plots data contains sufficient number to show the trend of characteristic features for EUT.

Conducted Spurious Emission

Report No. 13892671H
 Test place Ise EMC Lab. No.6 Measurement Room
 Date August 11, 2021
 Temperature / Humidity 23 deg. C / 60 % RH
 Engineer Junya Okuno
 Mode Tx BT LE 2402 MHz

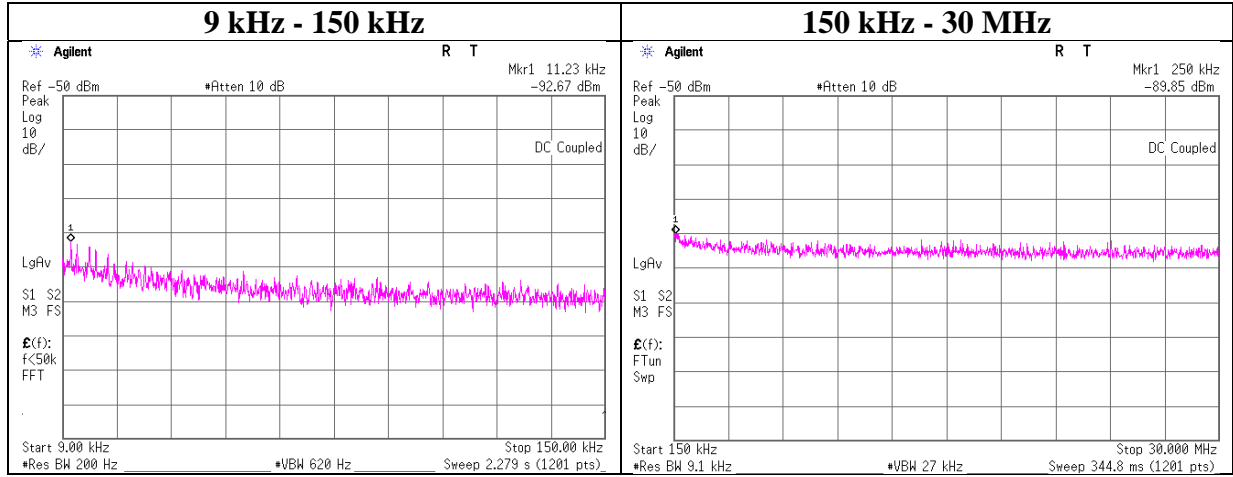

Frequency [kHz]	Reading [dBm]	Cable Loss [dB]	Attenuator Loss [dB]	Antenna Gain* [dBi]	N (Number of Output)	EIRP [dBm]	Distance [m]	Ground bounce [dB]	E (field strength) [dBuV/m]	Limit [dBuV/m]	Margin [dB]	Remark
11.23	-92.7	0.10	9.7	2.0	1	-80.9	300	6.0	-19.6	46.5	66.1	
250.00	-89.9	0.11	9.7	2.0	1	-78.1	300	6.0	-16.8	19.6	36.4	

$$E \text{ [dBuV/m]} = \text{EIRP [dBm]} - 20 \log(\text{Distance [m]}) + \text{Ground bounce [dB]} + 104.8 \text{ [dBuV/m]}$$

$$\text{EIRP [dBm]} = \text{Reading [dBm]} + \text{Cable loss [dB]} + \text{Attenuator Loss [dB]} + \text{Antenna gain [dBi]} + 10 * \log(N)$$

N: Number of output

*2.0 dBi was applied to the test result based on ANSI C63.10 since antenna gain was less than 2.0 dBi.

Conducted Spurious Emission

Report No. 13892671H
 Test place Ise EMC Lab. No.6 Measurement Room
 Date August 11, 2021
 Temperature / Humidity 23 deg. C / 60 % RH
 Engineer Junya Okuno
 Mode Tx BT LE 2440 MHz

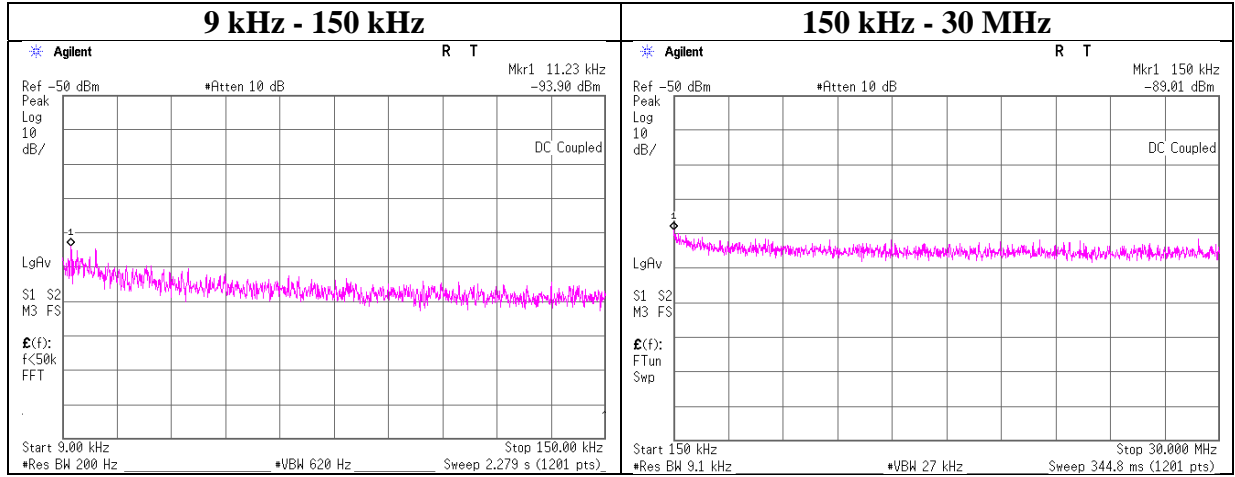

Frequency [kHz]	Reading [dBm]	Cable Loss [dB]	Attenuator Loss [dB]	Antenna Gain* [dBi]	N (Number of Output)	EIRP [dBm]	Distance [m]	Ground bounce [dB]	E (field strength) [dBuV/m]	Limit [dBuV/m]	Margin [dB]	Remark
11.23	-93.9	0.10	9.7	2.0	1	-82.1	300	6.0	-20.9	46.5	67.4	
150.00	-89.0	0.11	9.7	2.0	1	-77.2	300	6.0	-16.0	24.0	40.0	

$$E \text{ [dBuV/m]} = \text{EIRP [dBm]} - 20 \log (\text{Distance [m]}) + \text{Ground bounce [dB]} + 104.8 \text{ [dBuV/m]}$$

$$\text{EIRP [dBm]} = \text{Reading [dBm]} + \text{Cable loss [dB]} + \text{Attenuator Loss [dB]} + \text{Antenna gain [dBi]} + 10 * \log (N)$$

N: Number of output

*2.0 dBi was applied to the test result based on ANSI C63.10 since antenna gain was less than 2.0 dBi.

UL Japan, Inc.

Ise EMC Lab.

4383-326 Asama-cho, Ise-shi, Mie-ken 516-0021 JAPAN

Telephone : +81 596 24 8999

Facsimile : +81 596 24 8124

Conducted Spurious Emission

Report No. 13892671H
 Test place Ise EMC Lab. No.6 Measurement Room
 Date August 11, 2021
 Temperature / Humidity 23 deg. C / 60 % RH
 Engineer Junya Okuno
 Mode Tx BT LE 2480 MHz

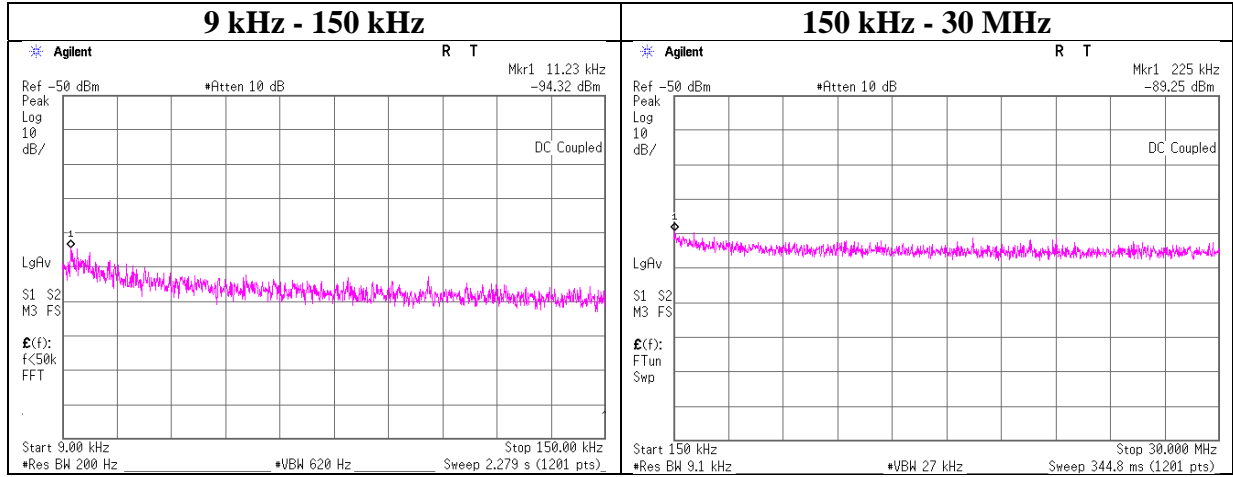

Frequency [kHz]	Reading [dBm]	Cable Loss [dB]	Attenuator Loss [dB]	Antenna Gain* [dBi]	N (Number of Output)	EIRP [dBm]	Distance [m]	Ground bounce [dB]	E (field strength) [dBuV/m]	Limit [dBuV/m]	Margin [dB]	Remark
11.23	-94.3	0.10	9.7	2.0	1	-82.5	300	6.0	-21.3	46.5	67.8	
225.00	-89.3	0.11	9.7	2.0	1	-77.5	300	6.0	-16.2	20.5	36.7	

$$E \text{ [dBuV/m]} = \text{EIRP [dBm]} - 20 \log(\text{Distance [m]}) + \text{Ground bounce [dB]} + 104.8 \text{ [dBuV/m]}$$

$$\text{EIRP [dBm]} = \text{Reading [dBm]} + \text{Cable loss [dB]} + \text{Attenuator Loss [dB]} + \text{Antenna gain [dBi]} + 10 * \log(N)$$

N: Number of output

*2.0 dBi was applied to the test result based on ANSI C63.10 since antenna gain was less than 2.0 dBi.

UL Japan, Inc.

Ise EMC Lab.

4383-326 Asama-cho, Ise-shi, Mie-ken 516-0021 JAPAN

Telephone : +81 596 24 8999

Facsimile : +81 596 24 8124

Power Density

Report No. 13892671H
Test place Ise EMC Lab. No.6 Measurement Room
Date August 11, 2021
Temperature / Humidity 23 deg. C / 60 % RH
Engineer Junya Okuno
Mode Tx BT LE

BT LE

Freq.	Reading	Cable Loss	Atten. Loss	Result	Limit	Margin
[MHz]	[dBm / 3 kHz]	[dB]	[dB]	[dBm / 3 kHz]	[dBm / 3 kHz]	[dB]
2402	-28.88	1.46	10.02	-17.40	8.00	25.40
2440	-29.01	1.47	10.02	-17.52	8.00	25.52
2480	-29.08	1.48	10.02	-17.58	8.00	25.58

Sample Calculation:

Result = Reading + Cable Loss (including the cable(s) customer supplied) + Attenuator Loss

Power Density

BT LE

2402 MHz

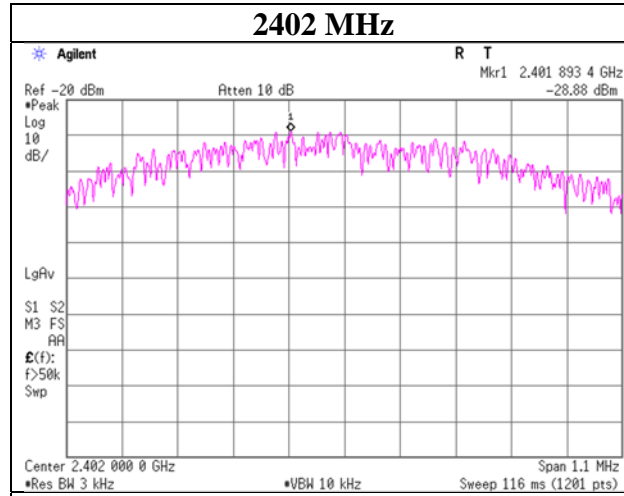

2440 MHz

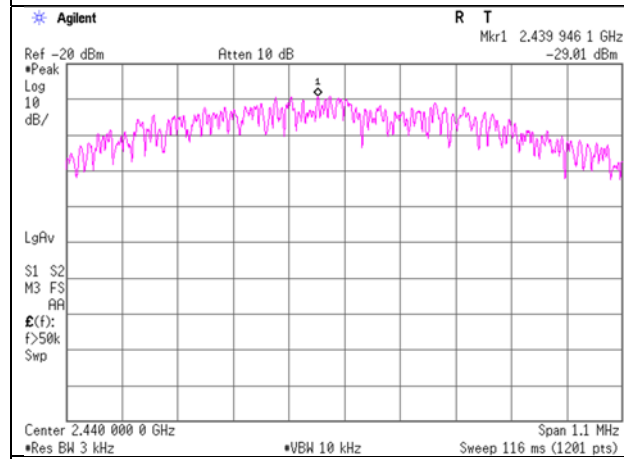

2480 MHz

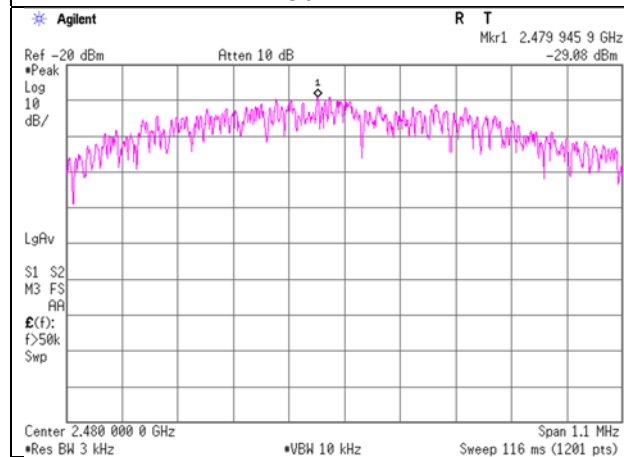

APPENDIX 2: Test instruments

Test equipment

Test Item	Local ID	LIMS ID	Description	Manufacturer	Model	Serial	Last Calibration Date	Cal Int
RE	MTR-08	141949	Test Receiver	Rohde & Schwarz	ESCI	100767	08/18/2020	12
RE	MSA-15	141902	Spectrum Analyzer	Keysight Technologies Inc	E4440A	MY46187105	10/15/2020	12
RE	MPA-10	141579	Pre Amplifier	Keysight Technologies Inc	8449B	3008A02142	02/18/2021	12
RE	MCC-218	141394	Microwave Cable	Junkosha	MWX221	1607S141(1 m) / 1608S264(5 m)	09/23/2020	12
RE	MHF-26	141296	High Pass Filter 3.5-18.0GHz	UL Japan	HPF SELECTOR	002	09/23/2020	12
RE	MHA-06	141512	Horn Antenna 1-18GHz	Schwarzbeck Mess-Elektronik OHG	BBHA9120D	254	09/14/2020	12
RE	MHA-16	141513	Horn Antenna 15-40GHz	Schwarzbeck Mess-Elektronik OHG	BBHA9170	BBHA9170306	06/07/2021	12
RE	MAT-07	141203	Attenuator(6dB)	Weinschel Corp	2	BK7970	11/13/2020	12
RE	LA-17	160924	Logperiodic Antenna	Schwarzbeck Mess-Elektronik OHG	VUSLP9111B	225	11/15/2020	12
RE	YBA-03	197990	Biconical Antenna	Schwarzbeck Mess-Elektronik OHG	VHBB 9124 + BBA 9106	01365	11/15/2020	12
RE	MCC-12	141317	Coaxial Cable	UL Japan Inc.	-	-	09/25/2020	12
RE	MPA-24	141594	Pre Amplifier	Keysight Technologies Inc	8447D	2944A10150	02/18/2021	12
RE	MAEC-02	142004	AC2_Semi Anechoic Chamber(NSA)	TDK	Semi Anechoic Chamber 3m	DA-06902	05/26/2020	24
RE	MOS-41	192300	Thermo-Hygrometer	CUSTOM. Inc	CTH-201	0013	12/06/2020	12
RE	MMM-01	141542	Digital Tester	Fluke Corporation	FLUKE 26-3	78030611	08/18/2020	12
RE	COTS-MEMI-02	178648	EMI measurement program	TSJ (Techno Science Japan)	TEPTO-DV	-	-	-
RE	MAEC-02-SVSWR	142006	AC2_Semi Anechoic Chamber(SVSWR)	TDK	Semi Anechoic Chamber 3m	DA-06902	04/09/2021	24
AT	MSA-15	141902	Spectrum Analyzer	Keysight Technologies Inc	E4440A	MY46187105	10/15/2020	12
AT	MPM-12	141809	Power Meter	Anritsu Corporation	ML2495A	825002	05/19/2021	12
AT	MPSE-11	141840	Power sensor	Anritsu Corporation	MA2411B	11737	10/15/2020	12
AT	MCC-66	141328	Microwave Cable 1G-40GHz	Suhner	SUCOFLEX102	28636/2	04/16/2021	12
AT	MAT-57	141333	Attenuator(10dB)	Suhner	6810.19.A	-	12/07/2020	12
AT	MCC-38	141395	Coaxial Cable	UL Japan	-	-	11/17/2020	12
AT	MAT-26	141244	Attenuator(10dB)	Weinschel - API Technologies Corp	WA8-10-34	A198	02/24/2021	12
AT	MOS-41	192300	Thermo-Hygrometer	CUSTOM. Inc	CTH-201	0013	12/06/2020	12

*Hyphens for Last Calibration Date and Cal Int (month) are instruments that Calibration is not required (e.g. software), or instruments checked in advance before use.

The expiration date of the calibration is the end of the expired month.

As for some calibrations performed after the tested dates, those test equipment have been controlled by means of an unbroken chains of calibrations.

All equipment is calibrated with valid calibrations. Each measurement data is traceable to the national or international standards.

Test item: RE: Radiated Emission test
AT: Antenna Terminal Conducted test

UL Japan, Inc.

Ise EMC Lab.

4383-326 Asama-cho, Ise-shi, Mie-ken 516-0021 JAPAN

Telephone : +81 596 24 8999

Facsimile : +81 596 24 8124