



FCC TEST REPORT

(15.407)

REPORT NO.: RF140625C09-1
MODEL NO.: PCE3302AN
FCC ID: Q6G-PCE3302
RECEIVED: Jun. 25, 2014
TESTED: Jul. 02 ~ Jul. 10, 2014
ISSUED: Jul. 31, 2014

APPLICANT: WatchGuard Technologies, Inc.

ADDRESS: 505 Fifth Avenue South, Suite 500, Seattle, WA
98104, United States

ISSUED BY: Bureau Veritas Consumer Products Services
(H.K.) Ltd., Taoyuan Branch

LAB ADDRESS: No. 47, 14th Ling, Chia Pau Vil., Lin Kou Dist.,
New Taipei City, Taiwan, R.O.C.

TEST LOCATION: No. 19, Hwa Ya 2nd Rd, Wen Hwa Tsuen, Kwei
Shan Hsiang, Taoyuan Hsien 333, Taiwan, R.O.C.

This report should not be used by the client to claim product certification, approval, or endorsement by TAF or any government agencies.



This report is for your exclusive use. Any copying or replication of this report to or for any other person or entity, or use of our name or trademark, is permitted only with our prior written permission. This report sets forth our findings solely with respect to the test samples identified herein. The results set forth in this report are not indicative or representative of the quality or characteristics of the lot from which a test sample was taken or any similar or identical product unless specifically and expressly noted. Our report includes all of the tests requested by you and the results thereof based upon the information that you provided to us. You have 60 days from date of issuance of this report to notify us of any material error or omission caused by our negligence, provided, however, that such notice shall be in writing and shall specifically address the issue you wish to raise. A failure to raise such issue within the prescribed time shall constitute your unqualified acceptance of the completeness of this report, the tests conducted and the correctness of the report contents. Unless specific mention, the uncertainty of measurement has been explicitly taken into account to declare the compliance or non-compliance to the specification.



TABLE OF CONTENTS

RELEASE CONTROL RECORD	4
1. CERTIFICATION	5
2. SUMMARY OF TEST RESULTS	6
2.1 MEASUREMENT UNCERTAINTY	6
3. GENERAL INFORMATION	7
3.1 GENERAL DESCRIPTION OF EUT	7
3.2 DESCRIPTION OF TEST MODES	8
3.2.1 TEST MODE APPLICABILITY AND TESTED CHANNEL DETAIL	9
3.3 DUTY CYCLE OF TEST SIGNAL	11
3.4 DESCRIPTION OF SUPPORT UNITS	12
3.4.1 CONFIGURATION OF SYSTEM UNDER TEST	12
3.5 GENERAL DESCRIPTION OF APPLIED STANDARDS	13
4. TEST TYPES AND RESULTS	14
4.1 RADIATED EMISSION AND BANDEDGE MEASUREMENT	14
4.1.1 LIMITS OF RADIATED EMISSION AND BANDEDGE MEASUREMENT	14
4.1.2 LIMITS OF UNWANTED EMISSION OUT OF THE RESTRICTED BANDS	14
4.1.3 TEST INSTRUMENTS	15
4.1.4 TEST PROCEDURES	16
4.1.5 DEVIATION FROM TEST STANDARD	16
4.1.6 TEST SETUP	17
4.1.7 EUT OPERATING CONDITION	18
4.1.8 TEST RESULTS	19
4.2 CONDUCTED EMISSION MEASUREMENT	36
4.2.1 LIMITS OF CONDUCTED EMISSION MEASUREMENT	36
4.2.2 TEST INSTRUMENTS	36
4.2.3 TEST PROCEDURES	37
4.2.4 DEVIATION FROM TEST STANDARD	37
4.2.5 TEST SETUP	37
4.2.6 EUT OPERATING CONDITIONS	37
4.2.7 TEST RESULTS	38
4.3 TRANSMIT POWER MEASUREMENT	40
4.3.1 LIMITS OF TRANSMIT POWER MEASUREMENT	40
4.3.2 TEST SETUP	40
4.3.3 TEST INSTRUMENTS	41
4.3.4 TEST PROCEDURE	41
4.3.5 DEVIATION FROM TEST STANDARD	41
4.3.6 EUT OPERATING CONDITIONS	41



A D T

4.3.7	TEST RESULTS	42
4.4	PEAK POWER SPECTRAL DENSITY MEASUREMENT.....	44
4.4.1	LIMITS OF PEAK POWER SPECTRAL DENSITY MEASUREMENT	44
4.4.2	TEST SETUP.....	44
4.4.3	TEST INSTRUMENTS	44
4.4.4	TEST PROCEDURES	44
4.4.5	DEVIATION FROM TEST STANDARD	45
4.4.6	EUT OPERATING CONDITIONS.....	45
4.4.7	TEST RESULTS	46
4.5	FREQUENCY STABILITY	50
4.5.1	LIMITS OF FREQUENCY STABILITY MEASUREMENT	50
4.5.2	TEST SETUP.....	50
4.5.3	TEST INSTRUMENTS	50
4.5.4	TEST PROCEDURE	51
4.5.5	DEVIATION FROM TEST STANDARD	51
4.5.6	EUT OPERATING CONDITION	51
4.5.7	TEST RESULTS	52
4.6	6dB BANDWIDTH MEASUREMENT	53
4.6.1	LIMITS OF 6dB BANDWIDTH MEASUREMENT.....	53
4.6.2	TEST SETUP.....	53
4.6.3	TEST INSTRUMENTS	53
4.6.4	TEST PROCEDURE	53
4.6.5	DEVIATION FROM TEST STANDARD	53
4.6.6	EUT OPERATING CONDITIONS.....	53
4.6.7	TEST RESULTS	54
5.	PHOTOGRAPHS OF THE TEST CONFIGURATION	56
6.	INFORMATION ON THE TESTING LABORATORIES.....	57
7.	APPENDIX A – MODIFICATIONS RECORDERS FOR ENGINEERING CHANGES TO THE EUT BY THE LAB	58



A D T

RELEASE CONTROL RECORD

ISSUE NO.	REASON FOR CHANGE	DATE ISSUED
RF140625C09-1	Original release	Jul. 31, 2014



1. CERTIFICATION

PRODUCT: Module

MODEL: PCE3302AN

BRAND: WatchGuard

APPLICANT: WatchGuard Technologies, Inc.

TESTED: Jul. 02 ~ Jul. 10, 2014

TEST SAMPLE: ENGINEERING SAMPLE

STANDARDS: FCC Part 15, Subpart E (Section 15.407)

ANSI C63.10-2009

The above equipment (model: PCE3302AN) has been tested by **Bureau Veritas Consumer Products Services (H.K.) Ltd., Taoyuan Branch**, and found compliance with the requirement of the above standards. The test record, data evaluation & Equipment Under Test (EUT) configurations represented herein are true and accurate accounts of the measurements of the sample's EMC characteristics under the conditions specified in this report.

PREPARED BY : Ivy Lin , **DATE :** Jul. 31, 2014
Ivy Lin / Specialist

APPROVED BY : Ken Liu , **DATE :** Jul. 31, 2014
Ken Liu / Senior Manager

2. SUMMARY OF TEST RESULTS

The EUT has been tested according to the following specifications:

APPLIED STANDARD: FCC PART 15, SUBPART E (SECTION 15.407)			
STANDARD SECTION	TEST TYPE	RESULT	REMARK
15.407(b)(6)	AC Power Conducted Emissions	PASS	Meet the requirement of limit. Minimum passing margin is -13.44dB at 0.55234MHz.
15.407(b)(1/2/3/4/6)	Radiated Emissions & Band Edge Measurement	PASS	Meet the requirement of limit. Minimum passing margin is -1.0dB at 5150.00MHz & 5722.90MHz.
15.407(a)(1/2/3)	Max Average Transmit Power	PASS	Meet the requirement of limit.
15.407(a)(1/2/3)	Peak Power Spectral Density	PASS	Meet the requirement of limit.
15.407(e)	6dB bandwidth	PASS	Meet the requirement of limit. (U-NII-3 Band only)
15.407(g)	Frequency Stability	PASS	Meet the requirement of limit.
15.203	Antenna Requirement	PASS	Antenna connector is IPEX not a standard connector.

2.1 MEASUREMENT UNCERTAINTY

Where relevant, the following measurement uncertainty levels have been estimated for tests performed on the EUT as specified in CISPR 16-4-2:

MEASUREMENT	FREQUENCY	UNCERTAINTY
Conducted emissions	9kHz~30MHz	2.44 dB
Radiated emissions	30MHz ~ 200MHz	3.34 dB
	200MHz ~ 1000MHz	3.35 dB
	1GHz ~ 18GHz	2.26 dB
	18GHz ~ 40GHz	1.94 dB

This uncertainty represents an expanded uncertainty expressed at approximately the 95% confidence level using a coverage factor of $k = 2$.

3. GENERAL INFORMATION

3.1 GENERAL DESCRIPTION OF EUT

EUT	Module
MODEL NO.	PCE3302AN
POWER SUPPLY	5Vdc (host equipment)
MODULATION TYPE	64QAM, 16QAM, QPSK, BPSK
MODULATION TECHNOLOGY	OFDM
TRANSFER RATE	802.11a: 54.0/ 48.0/ 36.0/ 24.0/ 18.0/ 12.0/ 9.0/ 6.0Mbps 802.11n: up to 300.0Mbps
OPERATING FREQUENCY	5180 ~ 5240MHz & 5745 ~ 5825MHz
NUMBER OF CHANNEL	5180 ~ 5240MHz: 4 for 802.11a, 802.11n (20MHz) 2 for 802.11n (40MHz) 5745 ~ 5825MHz: 5 for 802.11a, 802.11n (20MHz) 2 for 802.11n (40MHz)
OUTPUT POWER	111.986mW for 5180 ~ 5240MHz 86.080mW for 5745 ~ 5825MHz
ANTENNA TYPE	Refer to note
ANTENNA CONNECTOR	Refer to note
DATA CABLE	NA
I/O PORTS	Refer to user's manual
ACCESSORY DEVICES	NA

NOTE:

- The EUT incorporates a MIMO function. Physically, the EUT provides 2 completed transmitters and 2 receivers.

MODULATION MODE	TX FUNCTION
802.11a	2TX
802.11n (20MHz)	2TX
802.11n (40MHz)	2TX

- The following antenna is provided to the EUT.

Type	Connector	Gain(dBi)		
		2400 ~ 2483.5MHz	5180 ~ 5240MHz	5745 ~ 5825MHz
PIFA	IPEX	5.2	5.7	6.2

- The above EUT information is declared by manufacturer and for more detailed feature description, please refer to the manufacturer's specifications or user's manual.

3.2 DESCRIPTION OF TEST MODES

FOR 5180 ~ 5240MHz

4 channels are provided for 802.11a, 802.11n (20MHz):

CHANNEL	FREQUENCY	CHANNEL	FREQUENCY
36	5180 MHz	44	5220 MHz
40	5200 MHz	48	5240 MHz

2 channels are provided for 802.11n (40MHz):

CHANNEL	FREQUENCY	CHANNEL	FREQUENCY
38	5190 MHz	46	5230 MHz

FOR 5745 ~ 5825MHz

5 channels are provided for 802.11a, 802.11n (20MHz):

CHANNEL	FREQUENCY	CHANNEL	FREQUENCY
149	5745MHz	161	5805MHz
153	5765MHz	165	5825MHz
157	5785MHz		

2 channels are provided for 802.11n (40MHz):

CHANNEL	FREQUENCY	CHANNEL	FREQUENCY
151	5755MHz	159	5795MHz

FOR 5745 ~ 5825MHz:

5 channels are provided for 802.11a, 802.11n (20MHz), 802.11ac (20MHz):

CHANNEL	FREQUENCY	CHANNEL	FREQUENCY
149	5745MHz	161	5805MHz
153	5765MHz	165	5825MHz
157	5785MHz		

2 channels are provided for 802.11n (40MHz), 802.11ac (40MHz):

CHANNEL	FREQUENCY	CHANNEL	FREQUENCY
151	5755MHz	159	5795MHz

3.2.1 TEST MODE APPLICABILITY AND TESTED CHANNEL DETAIL

EUT CONFIGURE MODE	APPLICABLE TO				DESCRIPTION
	RE \geq 1G	RE $<$ 1G	PLC	APCM	
-	√	√	√	√	-

Where **RE \geq 1G**: Radiated Emission above 1GHz **RE $<$ 1G**: Radiated Emission below 1GHz
PLC: Power Line Conducted Emission **APCM**: Antenna Port Conducted Measurement

NOTE: The antenna had been pre-tested on the positioned of each 3 axis. The worst case was found when positioned on X-plane.

RADIATED EMISSION TEST (ABOVE 1GHz):

- Pre-Scan has been conducted to determine the worst-case mode from all possible combinations between available modulations, data rates and antenna ports (if EUT with antenna diversity architecture).
- Following channel(s) was (were) selected for the final test as listed below.

EUT CONFIGURE MODE	MODE	FREQ. BAND (MHz)	AVAILABLE CHANNEL	TESTED CHANNEL	MODULATION TECHNOLOGY	MODULATION TYPE	DATA RATE (Mbps)
-	802.11a	5180-5240	36 to 48	36, 40, 48	OFDM	BPSK	6.0
-	802.11n (20MHz)		36 to 48	36, 40, 48	OFDM	BPSK	7.2
-	802.11n (40MHz)		38 to 46	38, 46	OFDM	BPSK	15.0
-	802.11a	5745-5825	149 to 165	149, 157, 165	OFDM	BPSK	6.0
-	802.11n (20MHz)		149 to 165	149, 157, 165	OFDM	BPSK	7.2
-	802.11n (40MHz)		151 to 159	151, 159	OFDM	BPSK	15.0

RADIATED EMISSION TEST (BELOW 1GHz):

- Pre-Scan has been conducted to determine the worst-case mode from all possible combinations between available modulations, data rates and antenna ports (if EUT with antenna diversity architecture).
- Following channel(s) was (were) selected for the final test as listed below.

EUT CONFIGURE MODE	MODE	FREQ. BAND (MHz)	AVAILABLE CHANNEL	TESTED CHANNEL	MODULATION TECHNOLOGY	MODULATION TYPE	DATA RATE (Mbps)
-	802.11n (20MHz)	5180-5240, 5745-5825	36 to 48, 149 to 165	48	OFDM	BPSK	7.2

POWER LINE CONDUCTED EMISSION TEST:

- Pre-Scan has been conducted to determine the worst-case mode from all possible combinations between available modulations, data rates and antenna ports (if EUT with antenna diversity architecture).
- Following channel(s) was (were) selected for the final test as listed below.

EUT CONFIGURE MODE	MODE	FREQ. BAND (MHz)	AVAILABLE CHANNEL	TESTED CHANNEL	MODULATION TECHNOLOGY	MODULATION TYPE	DATA RATE (Mbps)
-	802.11n (20MHz)	5180-5240, 5745-5825	36 to 48, 149 to 165	48	OFDM	BPSK	7.2

ANTENNA PORT CONDUCTED MEASUREMENT:

- This item includes all test value of each mode, but only includes spectrum plot of worst value of each mode.
- Pre-Scan has been conducted to determine the worst-case mode from all possible combinations between available modulations, data rates and antenna ports (if EUT with antenna diversity architecture).
- Following channel(s) was (were) selected for the final test as listed below.

EUT CONFIGURE MODE	MODE	FREQ. BAND (MHz)	AVAILABLE CHANNEL	TESTED CHANNEL	MODULATION TECHNOLOGY	MODULATION TYPE	DATA RATE (Mbps)
-	802.11a	5180-5240	36 to 48	36, 40, 48	OFDM	BPSK	6.0
-	802.11n (20MHz)		36 to 48	36, 40, 48	OFDM	BPSK	7.2
-	802.11n (40MHz)		38 to 46	38, 46	OFDM	BPSK	15.0
-	802.11a	5745-5825	149 to 165	149, 157, 165	OFDM	BPSK	6.0
-	802.11n (20MHz)		149 to 165	149, 157, 165	OFDM	BPSK	7.2
-	802.11n (40MHz)		151 to 159	151, 159	OFDM	BPSK	15.0

TEST CONDITION:

APPLICABLE TO	ENVIRONMENTAL CONDITIONS	INPUT POWER	TESTED BY
RE \geq 1G	22deg. C, 65%RH	120Vac, 60Hz	Jones Chang
RE $<$ 1G	22deg. C, 65%RH	120Vac, 60Hz	Jones Chang
PLC	25deg. C, 70%RH	120Vac, 60Hz	Jones Chang
APCM	25deg. C, 60%RH	120Vac, 60Hz	Ted Chang

3.3 DUTY CYCLE OF TEST SIGNAL

Duty cycle of test signal is < 98 %, duty factor is required.

802.11a: Duty cycle = 1.358/1.405 = 0.967, Duty factor = $10 * \log(1/0.967) = 0.15$

802.11n (20MHz): Duty cycle = 1.270/1.316 = 0.965, Duty factor = $10 * \log(1/0.965) = 0.15$

802.11n (40MHz): Duty cycle = 631.0/673.0 = 0.938, Duty factor = $10 * \log(1/0.938) = 0.28$



3.4 DESCRIPTION OF SUPPORT UNITS

The EUT has been tested as an independent unit together with other necessary accessories or support units. The following support units or accessories were used to form a representative test configuration during the tests.

NO.	PRODUCT	BRAND	MODEL NO.	SERIAL NO.	FCC ID
1	Notebook	DELL	E5420	33MJMQ1	FCC DoC Approved
2	Convertible board	NA	NA	NA	NA

NO.	SIGNAL CABLE DESCRIPTION OF THE ABOVE SUPPORT UNITS
1	NA
2	NA

NOTE:

1. All power cords of the above support units are non-shielded (1.8m).
2. Convertible board is used to control EUT transmit at specific channel.

3.4.1 CONFIGURATION OF SYSTEM UNDER TEST

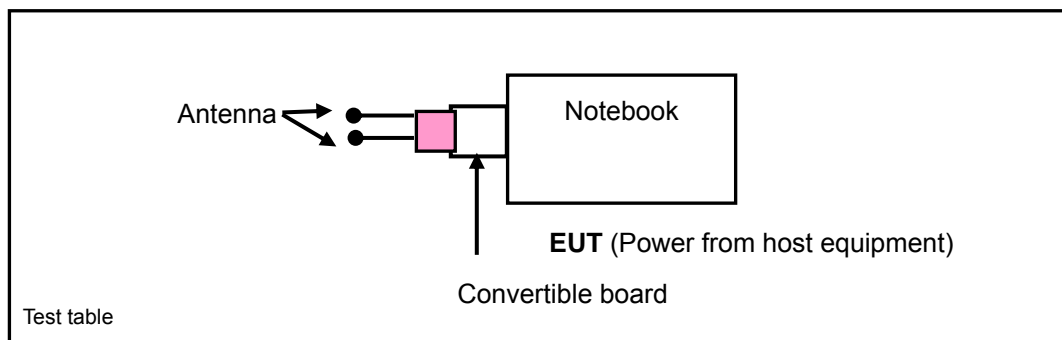

3.5 GENERAL DESCRIPTION OF APPLIED STANDARDS

The EUT is a RF Product. According to the specification of the EUT declared by the manufacturer, it must comply with the requirements of the following standards:

FCC Part 15, Subpart E (15.407)

789033 D02 General UNII Test Procedures New Rules v01

662911 D01 Multiple Transmitter Output v02r01

ANSI C63.10-2009

All test items have been performed and recorded as per the above standards.

4. TEST TYPES AND RESULTS

4.1 RADIATED EMISSION AND BANDEDGE MEASUREMENT

4.1.1 LIMITS OF RADIATED EMISSION AND BANDEDGE MEASUREMENT

Radiated emissions which fall in the restricted bands must comply with the radiated emission limits specified as below table:

FREQUENCIES (MHz)	FIELD STRENGTH (microvolts/meter)	MEASUREMENT DISTANCE (meters)
0.009 ~ 0.490	2400/F(kHz)	300
0.490 ~ 1.705	24000/F(kHz)	30
1.705 ~ 30.0	30	30
30 ~ 88	100	3
88 ~ 216	150	3
216 ~ 960	200	3
Above 960	500	3

NOTE:

1. The lower limit shall apply at the transition frequencies.
2. Emission level (dBuV/m) = 20 log Emission level (uV/m).
3. For frequencies above 1000MHz, the field strength limits are based on average detector, however, the peak field strength of any emission shall not exceed the maximum permitted average limits, specified above by more than 20dB under any condition of modulation.

4.1.2 LIMITS OF UNWANTED EMISSION OUT OF THE RESTRICTED BANDS

APPLICABLE TO	LIMIT	
789033 D02 General UNII Test Procedures New Rules v01	FIELD STRENGTH AT 3m	
	PK: 74 (dBµV/m)	AV: 54 (dBµV/m)
APPLICABLE TO	EIRP LIMIT	EQUIVALENT FIELD STRENGTH AT 3m
15.407(b)(1)	PK: -27 (dBm/MHz)	PK: 68.2 (dBµV/m)
15.407(b)(2)		
15.407(b)(3)		
15.407(b)(4)	PK: -27 (dBm/MHz) ^{*1} PK: -17 (dBm/MHz) ^{*2}	PK: 68.2 (dBµV/m) ^{*1} PK: 78.2 (dBµV/m) ^{*2}

NOTE: ^{*1} beyond 10MHz of the band edge ^{*2} within 10 MHz of band edge

The following formula is used to convert the equipment isotropic radiated power (eirp) to field strength:

$$E = \frac{1000000\sqrt{30P}}{3} \mu\text{V/m, where P is the eirp (Watts).}$$

4.1.3 TEST INSTRUMENTS

DESCRIPTION & MANUFACTURER	MODEL NO.	SERIAL NO.	DATE OF CALIBRATION	DUE DATE OF CALIBRATION
Test Receiver ROHDE & SCHWARZ	ESIB7	100187	Jan. 02, 2014	Jan. 01, 2015
Spectrum Analyzer ROHDE & SCHWARZ	FSP40	100039	Mar. 03, 2014	Mar. 02, 2015
BILOG Antenna SCHWARZBECK	VULB9168	9168-160	Feb. 26, 2014	Feb. 25, 2015
HORN Antenna SCHWARZBECK	9120D	209	Sep. 12, 2013	Sep. 11, 2014
HORN Antenna SCHWARZBECK	BBHA 9170	BBHA9170241	Feb. 17, 2014	Feb. 16, 2015
Preamplifier Agilent	8447D	2944A10633	Oct. 07, 2013	Oct. 06, 2014
Preamplifier Agilent	8449B	3008A01964	Aug. 26, 2013	Aug. 25, 2014
RF signal cable HUBER+SUHNNER	SUCOFLEX 104	214378/4	Aug. 26, 2013	Aug. 25, 2014
RF signal cable HUBER+SUHNNER	SUCOFLEX 106	12738/6 +309224/4	Aug. 26, 2013	Aug. 25, 2014
Software BV ADT	ADT_Radiated_ V7.6.15.9.4	NA	NA	NA
Antenna Tower inn-co GmbH	MA 4000	013303	NA	NA
Antenna Tower Controller inn-co GmbH	CO2000	017303	NA	NA
Turn Table BV ADT	TT100	TT93021703	NA	NA
Turn Table Controller BV ADT	SC100	SC93021703	NA	NA
26GHz ~ 40GHz Amplifier	EM26400	815221	Oct. 18, 2013	Oct. 17, 2014
High Speed Peak Power Meter	ML2495A	0824011	Jul. 29, 2013	Jul. 28, 2014
Power Sensor	MA2411B	0738171	Jul. 29, 2013	Jul. 28, 2014
WIT Standard Temperature And Humidity Chamber	TH-4S-C	W981030	Jun. 09, 2014	Jun. 08, 2015

- NOTE:**
1. The calibration interval of the above test instruments is 12 months and the calibrations are traceable to NML/ROC and NIST/USA.
 2. The test was performed in HwaYa Chamber 3.
 3. The horn antenna and HP preamplifier (model: 8449B) are used only for the measurement of emission frequency above 1GHz if tested.
 4. The FCC Site Registration No. is 988962.
 5. The IC Site Registration No. is IC 7450F-3.

4.1.4 TEST PROCEDURES

- a. The EUT was placed on the top of a rotating table 0.8 meters above the ground at a 3 meter semi-anechoic chamber. The table was rotated 360 degrees to determine the position of the highest radiation.
- b. The EUT was set 3 meters away from the interference-receiving antenna, which was mounted on the top of a variable-height antenna tower.
- c. The antenna is a broadband antenna, and its height is varied from one meter to four meters above the ground to determine the maximum value of the field strength. Both horizontal and vertical polarizations of the antenna are set to make the measurement.
- d. For each suspected emission, the EUT was arranged to its worst case and then the antenna was tuned to heights from 1 meter to 4 meters and the rotatable table was turned from 0 degrees to 360 degrees to find the maximum reading.
- e. The test-receiver system was set to Peak Detect Function and Specified Bandwidth with Maximum Hold Mode.
- f. If the emission level of the EUT in peak mode was 10dB lower than the limit specified, then testing could be stopped and the peak values of the EUT would be reported. Otherwise the emissions that did not have 10dB margin would be re-tested one by one using peak, quasi-peak or average method as specified and then reported in a data sheet.

NOTE:

1. The resolution bandwidth and video bandwidth of test receiver/spectrum analyzer is 120kHz for Quasi-peak detection at frequency below 1GHz.
2. The resolution bandwidth of test receiver/spectrum analyzer is 1MHz and video bandwidth is 3MHz for Peak detection at frequency above 1GHz.
3. The resolution bandwidth of test receiver/spectrum analyzer is 1MHz and the video bandwidth is $\geq 1/T$ (Duty cycle < 98%) or 10Hz (Duty cycle > 98%) for Average detection (AV) at frequency above 1GHz.
4. All modes of operation were investigated and the worst-case emissions are reported.

4.1.5 DEVIATION FROM TEST STANDARD

No deviation.

4.1.6 TEST SETUP

Frequency range 30MHz~1GHz

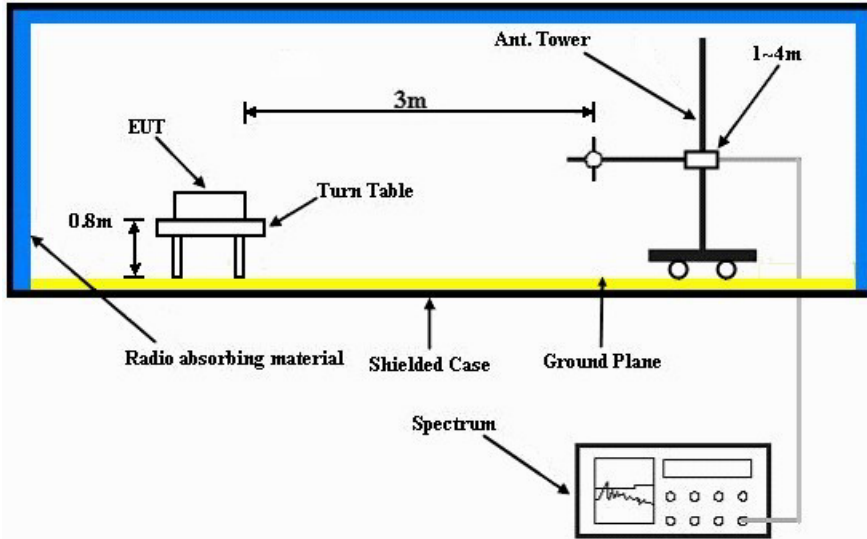

Frequency range above 1GHz

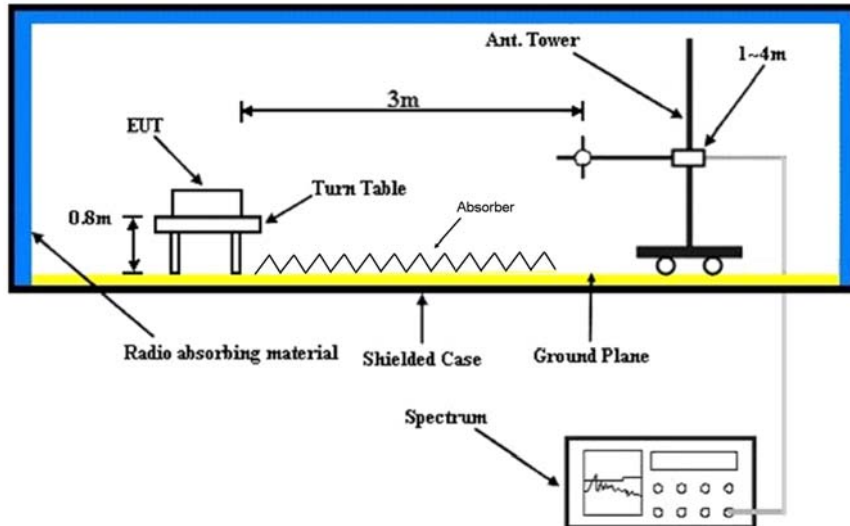

For the actual test configuration, please refer to the attached file (Test Setup Photo).

4.1.7 EUT OPERATING CONDITION

- a. Plugged the EUT into notebook via external board and placed them on the testing table.
- b. The notebook system ran a test program (provided by manufacturer) to enable EUT under transmission condition continuously at specific channel frequency.
- c. The necessary accessories enable the system in full functions.

4.1.8 TEST RESULTS

ABOVE 1GHz DATA

For U-NII-1 Band

802.11a

CHANNEL	TX Channel 36	DETECTOR FUNCTION	Peak (PK)
FREQUENCY RANGE	1GHz ~ 40GHz		Average (AV)

ANTENNA POLARITY & TEST DISTANCE: HORIZONTAL AT 3 M								
NO.	FREQ. (MHz)	EMISSION LEVEL (dBuV/m)	LIMIT (dBuV/m)	MARGIN (dB)	ANTENNA HEIGHT (m)	TABLE ANGLE (Degree)	RAW VALUE (dBuV)	CORRECTION FACTOR (dB/m)
1	5150.00	72.3 PK	74.0	-1.7	1.48 H	86	67.20	5.10
2	5150.00	52.0 AV	54.0	-2.0	1.48 H	86	46.90	5.10
3	*5180.00	112.8 PK			1.51 H	89	75.10	37.70
4	*5180.00	102.9 AV			1.51 H	89	65.20	37.70
5	#10360.00	61.6 PK	68.2	-6.6	1.54 H	98	43.30	18.30
ANTENNA POLARITY & TEST DISTANCE: VERTICAL AT 3 M								
NO.	FREQ. (MHz)	EMISSION LEVEL (dBuV/m)	LIMIT (dBuV/m)	MARGIN (dB)	ANTENNA HEIGHT (m)	TABLE ANGLE (Degree)	RAW VALUE (dBuV)	CORRECTION FACTOR (dB/m)
1	5150.00	58.5 PK	74.0	-15.5	1.14 V	335	53.40	5.10
2	5150.00	45.3 AV	54.0	-8.7	1.14 V	335	40.20	5.10
3	*5180.00	102.0 PK			1.03 V	334	64.30	37.70
4	*5180.00	92.2 AV			1.03 V	334	54.50	37.70
5	#10360.00	60.9 PK	68.2	-7.3	1.14 V	292	42.60	18.30

REMARKS:

1. Emission Level(dBuV/m) = Raw Value(dBuV) + Correction Factor(dB/m)
2. Correction Factor(dB/m) = Antenna Factor(dB/m) + Cable Factor(dB)
3. The other emission levels were very low against the limit.
4. Margin value = Emission Level – Limit value
5. " * ": Fundamental frequency.
6. " # ": The radiated frequency is out of the restricted band.

CHANNEL	TX Channel 40	DETECTOR FUNCTION	Peak (PK)
FREQUENCY RANGE	1GHz ~ 40GHz		Average (AV)

ANTENNA POLARITY & TEST DISTANCE: HORIZONTAL AT 3 M								
NO.	FREQ. (MHz)	EMISSION LEVEL (dBuV/m)	LIMIT (dBuV/m)	MARGIN (dB)	ANTENNA HEIGHT (m)	TABLE ANGLE (Degree)	RAW VALUE (dBuV)	CORRECTION FACTOR (dB/m)
1	5120.00	62.3 PK	74.0	-11.7	1.46 H	88	57.20	5.10
2	5120.00	52.1 AV	54.0	-1.9	1.46 H	88	47.00	5.10
3	5150.00	67.5 PK	74.0	-6.5	1.36 H	95	62.40	5.10
4	5150.00	51.4 AV	54.0	-2.6	1.36 H	95	46.30	5.10
5	*5200.00	117.1 PK			1.48 H	91	79.30	37.80
6	*5200.00	107.1 AV			1.48 H	91	69.30	37.80
7	#10400.00	61.6 PK	68.2	-6.6	1.48 H	10	42.90	18.70
ANTENNA POLARITY & TEST DISTANCE: VERTICAL AT 3 M								
NO.	FREQ. (MHz)	EMISSION LEVEL (dBuV/m)	LIMIT (dBuV/m)	MARGIN (dB)	ANTENNA HEIGHT (m)	TABLE ANGLE (Degree)	RAW VALUE (dBuV)	CORRECTION FACTOR (dB/m)
1	5120.00	57.4 PK	74.0	-16.6	1.21 V	24	52.30	5.10
2	5120.00	45.1 AV	54.0	-8.9	1.21 V	24	40.00	5.10
3	5150.00	56.0 PK	74.0	-18.0	1.16 V	106	50.90	5.10
4	5150.00	45.3 AV	54.0	-8.7	1.16 V	106	40.20	5.10
5	*5200.00	106.2 PK			1.16 V	341	68.40	37.80
6	*5200.00	95.4 AV			1.16 V	341	57.60	37.80
7	#10400.00	60.1 PK	68.2	-8.1	1.20 V	272	41.40	18.70

REMARKS:

1. Emission Level(dBuV/m) = Raw Value(dBuV) + Correction Factor(dB/m)
2. Correction Factor(dB/m) = Antenna Factor(dB/m) + Cable Factor(dB)
3. The other emission levels were very low against the limit.
4. Margin value = Emission Level – Limit value
5. " * ": Fundamental frequency.
6. " # ": The radiated frequency is out of the restricted band.

CHANNEL	TX Channel 48	DETECTOR FUNCTION	Peak (PK)
FREQUENCY RANGE	1GHz ~ 40GHz		Average (AV)

ANTENNA POLARITY & TEST DISTANCE: HORIZONTAL AT 3 M								
NO.	FREQ. (MHz)	EMISSION LEVEL (dBuV/m)	LIMIT (dBuV/m)	MARGIN (dB)	ANTENNA HEIGHT (m)	TABLE ANGLE (Degree)	RAW VALUE (dBuV)	CORRECTION FACTOR (dB/m)
1	5120.00	62.0 PK	74.0	-12.0	1.39 H	92	56.90	5.10
2	5120.00	52.2 AV	54.0	-1.8	1.39 H	92	47.10	5.10
3	*5240.00	116.5 PK			1.53 H	92	78.60	37.90
4	*5240.00	105.8 AV			1.53 H	92	67.90	37.90
5	5350.00	61.6 PK	74.0	-12.4	1.36 H	89	56.20	5.40
6	5350.00	49.2 AV	54.0	-4.8	1.36 H	89	43.80	5.40
7	#10480.00	61.0 PK	68.2	-7.2	1.34 H	28	41.50	19.50
ANTENNA POLARITY & TEST DISTANCE: VERTICAL AT 3 M								
NO.	FREQ. (MHz)	EMISSION LEVEL (dBuV/m)	LIMIT (dBuV/m)	MARGIN (dB)	ANTENNA HEIGHT (m)	TABLE ANGLE (Degree)	RAW VALUE (dBuV)	CORRECTION FACTOR (dB/m)
1	5120.00	56.8 PK	74.0	-17.2	1.16 V	273	51.70	5.10
2	5120.00	45.5 AV	54.0	-8.5	1.16 V	273	40.40	5.10
3	*5240.00	102.4 PK			1.19 V	332	64.50	37.90
4	*5240.00	91.9 AV			1.19 V	332	54.00	37.90
5	5350.00	56.2 PK	74.0	-17.8	1.19 V	348	50.80	5.40
6	5350.00	44.4 AV	54.0	-9.6	1.19 V	348	39.00	5.40
7	#10480.00	60.5 PK	68.2	-7.7	1.23 V	246	41.00	19.50

REMARKS:

1. Emission Level(dBuV/m) = Raw Value(dBuV) + Correction Factor(dB/m)
2. Correction Factor(dB/m) = Antenna Factor(dB/m) + Cable Factor(dB)
3. The other emission levels were very low against the limit.
4. Margin value = Emission Level – Limit value
5. " * ": Fundamental frequency.
6. " # ": The radiated frequency is out of the restricted band.



A D T

802.11n (20MHz)

CHANNEL	TX Channel 36	DETECTOR FUNCTION	Peak (PK)
FREQUENCY RANGE	1GHz ~ 40GHz		Average (AV)

ANTENNA POLARITY & TEST DISTANCE: HORIZONTAL AT 3 M								
NO.	FREQ. (MHz)	EMISSION LEVEL (dBuV/m)	LIMIT (dBuV/m)	MARGIN (dB)	ANTENNA HEIGHT (m)	TABLE ANGLE (Degree)	RAW VALUE (dBuV)	CORRECTION FACTOR (dB/m)
1	5150.00	72.3 PK	74.0	-1.7	1.47 H	84	67.20	5.10
2	5150.00	51.3 AV	54.0	-2.7	1.47 H	84	46.20	5.10
3	*5180.00	113.4 PK			1.49 H	92	75.70	37.70
4	*5180.00	103.4 AV			1.49 H	92	65.70	37.70
5	#10360.00	60.8 PK	68.2	-7.4	1.35 H	143	42.50	18.30
ANTENNA POLARITY & TEST DISTANCE: VERTICAL AT 3 M								
NO.	FREQ. (MHz)	EMISSION LEVEL (dBuV/m)	LIMIT (dBuV/m)	MARGIN (dB)	ANTENNA HEIGHT (m)	TABLE ANGLE (Degree)	RAW VALUE (dBuV)	CORRECTION FACTOR (dB/m)
1	5150.00	55.6 PK	74.0	-18.4	1.10 V	71	50.50	5.10
2	5150.00	45.3 AV	54.0	-8.7	1.10 V	71	40.20	5.10
3	*5180.00	100.1 PK			1.17 V	342	62.40	37.70
4	*5180.00	90.1 AV			1.17 V	342	52.40	37.70
5	#10360.00	59.6 PK	68.2	-8.6	1.00 V	119	41.30	18.30

REMARKS:

1. Emission Level(dBuV/m) = Raw Value(dBuV) + Correction Factor(dB/m)
2. Correction Factor(dB/m) = Antenna Factor(dB/m) + Cable Factor(dB)
3. The other emission levels were very low against the limit.
4. Margin value = Emission Level – Limit value
5. " * ": Fundamental frequency.
6. " # ": The radiated frequency is out of the restricted band.

CHANNEL	TX Channel 40	DETECTOR FUNCTION	Peak (PK)
FREQUENCY RANGE	1GHz ~ 40GHz		Average (AV)

ANTENNA POLARITY & TEST DISTANCE: HORIZONTAL AT 3 M								
NO.	FREQ. (MHz)	EMISSION LEVEL (dBuV/m)	LIMIT (dBuV/m)	MARGIN (dB)	ANTENNA HEIGHT (m)	TABLE ANGLE (Degree)	RAW VALUE (dBuV)	CORRECTION FACTOR (dB/m)
1	5120.00	62.4 PK	74.0	-11.6	1.46 H	89	57.30	5.10
2	5120.00	51.7 AV	54.0	-2.3	1.46 H	89	46.60	5.10
3	5150.00	72.9 PK	74.0	-1.1	1.41 H	87	67.80	5.10
4	5150.00	51.1 AV	54.0	-2.9	1.41 H	87	46.00	5.10
5	*5200.00	116.4 PK			1.41 H	91	78.60	37.80
6	*5200.00	106.3 AV			1.41 H	91	68.50	37.80
7	#10400.00	61.4 PK	68.2	-6.8	1.31 H	159	42.70	18.70
ANTENNA POLARITY & TEST DISTANCE: VERTICAL AT 3 M								
NO.	FREQ. (MHz)	EMISSION LEVEL (dBuV/m)	LIMIT (dBuV/m)	MARGIN (dB)	ANTENNA HEIGHT (m)	TABLE ANGLE (Degree)	RAW VALUE (dBuV)	CORRECTION FACTOR (dB/m)
1	5120.00	55.3 PK	74.0	-18.7	1.10 V	63	50.20	5.10
2	5120.00	44.2 AV	54.0	-9.8	1.10 V	63	39.10	5.10
3	5150.00	56.1 PK	74.0	-17.9	1.18 V	293	51.00	5.10
4	5150.00	45.5 AV	54.0	-8.5	1.18 V	293	40.40	5.10
5	*5200.00	105.6 PK			1.14 V	341	67.80	37.80
6	*5200.00	95.0 AV			1.14 V	341	57.20	37.80
7	#10400.00	60.2 PK	68.2	-8.0	1.21 V	289	41.50	18.70

REMARKS:

1. Emission Level(dBuV/m) = Raw Value(dBuV) + Correction Factor(dB/m)
2. Correction Factor(dB/m) = Antenna Factor(dB/m) + Cable Factor(dB)
3. The other emission levels were very low against the limit.
4. Margin value = Emission Level – Limit value
5. " * ": Fundamental frequency.
6. " # ": The radiated frequency is out of the restricted band.



CHANNEL	TX Channel 48	DETECTOR FUNCTION	Peak (PK)
FREQUENCY RANGE	1GHz ~ 40GHz		Average (AV)

ANTENNA POLARITY & TEST DISTANCE: HORIZONTAL AT 3 M								
NO.	FREQ. (MHz)	EMISSION LEVEL (dBuV/m)	LIMIT (dBuV/m)	MARGIN (dB)	ANTENNA HEIGHT (m)	TABLE ANGLE (Degree)	RAW VALUE (dBuV)	CORRECTION FACTOR (dB/m)
1	5040.00	60.1 PK	74.0	-13.9	1.48 H	85	55.00	5.10
2	5040.00	52.2 AV	54.0	-1.8	1.48 H	85	47.10	5.10
3	*5240.00	117.2 PK			1.47 H	90	79.30	37.90
4	*5240.00	106.7 AV			1.47 H	90	68.80	37.90
5	5350.00	59.9 PK	74.0	-14.1	1.51 H	108	54.50	5.40
6	5350.00	48.4 AV	54.0	-5.6	1.51 H	108	43.00	5.40
7	#10480.00	62.4 PK	68.2	-5.8	1.33 H	104	42.90	19.50
ANTENNA POLARITY & TEST DISTANCE: VERTICAL AT 3 M								
NO.	FREQ. (MHz)	EMISSION LEVEL (dBuV/m)	LIMIT (dBuV/m)	MARGIN (dB)	ANTENNA HEIGHT (m)	TABLE ANGLE (Degree)	RAW VALUE (dBuV)	CORRECTION FACTOR (dB/m)
1	5040.00	56.5 PK	74.0	-17.5	1.09 V	54	51.40	5.10
2	5040.00	45.7 AV	54.0	-8.3	1.09 V	54	40.60	5.10
3	*5240.00	104.9 PK			1.01 V	346	67.00	37.90
4	*5240.00	94.3 AV			1.01 V	346	56.40	37.90
5	5350.00	55.7 PK	74.0	-18.3	1.01 V	233	50.30	5.40
6	5350.00	45.3 AV	54.0	-8.7	1.01 V	233	39.90	5.40
7	#10480.00	61.5 PK	68.2	-6.7	1.03 V	359	42.00	19.50

REMARKS:

1. Emission Level(dBuV/m) = Raw Value(dBuV) + Correction Factor(dB/m)
2. Correction Factor(dB/m) = Antenna Factor(dB/m) + Cable Factor(dB)
3. The other emission levels were very low against the limit.
4. Margin value = Emission Level – Limit value
5. " * ": Fundamental frequency.
6. " # ": The radiated frequency is out of the restricted band.



A D T

802.11n (40MHz)

CHANNEL	TX Channel 38	DETECTOR FUNCTION	Peak (PK)
FREQUENCY RANGE	1GHz ~ 40GHz		Average (AV)

ANTENNA POLARITY & TEST DISTANCE: HORIZONTAL AT 3 M								
NO.	FREQ. (MHz)	EMISSION LEVEL (dBuV/m)	LIMIT (dBuV/m)	MARGIN (dB)	ANTENNA HEIGHT (m)	TABLE ANGLE (Degree)	RAW VALUE (dBuV)	CORRECTION FACTOR (dB/m)
1	5150.00	73.0 PK	74.0	-1.0	1.43 H	85	67.90	5.10
2	5150.00	51.4 AV	54.0	-2.6	1.43 H	85	46.30	5.10
3	*5190.00	106.7 PK			1.49 H	90	68.90	37.80
4	*5190.00	97.4 AV			1.49 H	90	59.60	37.80
5	#10380.00	60.5 PK	68.2	-7.7	1.38 H	156	42.10	18.40
ANTENNA POLARITY & TEST DISTANCE: VERTICAL AT 3 M								
NO.	FREQ. (MHz)	EMISSION LEVEL (dBuV/m)	LIMIT (dBuV/m)	MARGIN (dB)	ANTENNA HEIGHT (m)	TABLE ANGLE (Degree)	RAW VALUE (dBuV)	CORRECTION FACTOR (dB/m)
1	5150.00	55.5 PK	74.0	-18.5	1.10 V	326	50.40	5.10
2	5150.00	44.9 AV	54.0	-9.1	1.10 V	326	39.80	5.10
3	*5190.00	95.1 PK			1.14 V	340	57.30	37.80
4	*5190.00	85.4 AV			1.14 V	340	47.60	37.80
5	#10380.00	60.3 PK	68.2	-7.9	1.40 V	108	41.90	18.40

REMARKS:

1. Emission Level(dBuV/m) = Raw Value(dBuV) + Correction Factor(dB/m)
2. Correction Factor(dB/m) = Antenna Factor(dB/m) + Cable Factor(dB)
3. The other emission levels were very low against the limit.
4. Margin value = Emission Level – Limit value
5. " * ": Fundamental frequency.
6. " # ": The radiated frequency is out of the restricted band.

CHANNEL	TX Channel 46	DETECTOR FUNCTION	Peak (PK)
FREQUENCY RANGE	1GHz ~ 40GHz		Average (AV)

ANTENNA POLARITY & TEST DISTANCE: HORIZONTAL AT 3 M								
NO.	FREQ. (MHz)	EMISSION LEVEL (dBuV/m)	LIMIT (dBuV/m)	MARGIN (dB)	ANTENNA HEIGHT (m)	TABLE ANGLE (Degree)	RAW VALUE (dBuV)	CORRECTION FACTOR (dB/m)
1	5150.00	72.2 PK	74.0	-1.8	1.52 H	81	67.10	5.10
2	5150.00	51.2 AV	54.0	-2.8	1.52 H	81	46.10	5.10
3	*5230.00	112.8 PK			1.50 H	92	74.90	37.90
4	*5230.00	102.3 AV			1.50 H	92	64.40	37.90
5	5350.00	57.4 PK	74.0	-16.6	1.40 H	171	52.00	5.40
6	5350.00	46.0 AV	54.0	-8.0	1.40 H	171	40.60	5.40
7	#10460.00	61.8 PK	68.2	-6.4	1.34 H	299	42.60	19.20
ANTENNA POLARITY & TEST DISTANCE: VERTICAL AT 3 M								
NO.	FREQ. (MHz)	EMISSION LEVEL (dBuV/m)	LIMIT (dBuV/m)	MARGIN (dB)	ANTENNA HEIGHT (m)	TABLE ANGLE (Degree)	RAW VALUE (dBuV)	CORRECTION FACTOR (dB/m)
1	5150.00	55.6 PK	74.0	-18.4	1.20 V	260	50.50	5.10
2	5150.00	44.3 AV	54.0	-9.7	1.20 V	260	39.20	5.10
3	*5230.00	100.6 PK			1.40 V	342	62.70	37.90
4	*5230.00	90.9 AV			1.40 V	342	53.00	37.90
5	5350.00	55.5 PK	74.0	-18.5	1.00 V	269	50.10	5.40
6	5350.00	45.4 AV	54.0	-8.6	1.00 V	269	40.00	5.40
7	#10460.00	61.0 PK	68.2	-7.2	1.14 V	10	41.80	19.20

REMARKS:

1. Emission Level(dBuV/m) = Raw Value(dBuV) + Correction Factor(dB/m)
2. Correction Factor(dB/m) = Antenna Factor(dB/m) + Cable Factor(dB)
3. The other emission levels were very low against the limit.
4. Margin value = Emission Level – Limit value
5. " * ": Fundamental frequency.
6. " # ": The radiated frequency is out of the restricted band.



A D T

ABOVE 1GHz DATA

For U-NII-3 Band

802.11a

CHANNEL	TX Channel 149	DETECTOR FUNCTION	Peak (PK)
FREQUENCY RANGE	1GHz ~ 40GHz		Average (AV)

ANTENNA POLARITY & TEST DISTANCE: HORIZONTAL AT 3 M

NO.	FREQ. (MHz)	EMISSION LEVEL (dBuV/m)	LIMIT (dBuV/m)	MARGIN (dB)	ANTENNA HEIGHT (m)	TABLE ANGLE (Degree)	RAW VALUE (dBuV)	CORRECTION FACTOR (dB/m)
1	#5714.00	71.5 PK	74.0	-2.5	1.40 H	80	65.50	6.00
2	#5714.00	51.6 AV	54.0	-2.4	1.40 H	80	45.60	6.00
3	#5722.90	77.2 PK	78.2	-1.0	1.46 H	81	71.20	6.00
4	#5725.00	72.4 PK	78.2	-5.8	1.42 H	82	66.40	6.00
5	*5745.00	113.8 PK			1.43 H	85	75.30	38.50
6	*5745.00	104.3 AV			1.43 H	85	65.80	38.50
7	11490.00	63.7 PK	74.0	-10.3	1.50 H	146	43.30	20.40
8	11490.00	49.5 AV	54.0	-4.5	1.50 H	146	29.10	20.40

ANTENNA POLARITY & TEST DISTANCE: VERTICAL AT 3 M

NO.	FREQ. (MHz)	EMISSION LEVEL (dBuV/m)	LIMIT (dBuV/m)	MARGIN (dB)	ANTENNA HEIGHT (m)	TABLE ANGLE (Degree)	RAW VALUE (dBuV)	CORRECTION FACTOR (dB/m)
1	#5714.00	56.3 PK	74.0	-17.7	1.22 V	330	50.30	6.00
2	#5714.00	45.5 AV	54.0	-8.5	1.22 V	330	39.50	6.00
3	#5722.00	61.1 PK	78.2	-17.1	1.20 V	350	55.10	6.00
4	#5725.00	65.9 PK	78.2	-12.3	1.30 V	344	59.90	6.00
5	*5745.00	100.1 PK			1.22 V	15	61.60	38.50
6	*5745.00	90.0 AV			1.22 V	15	51.50	38.50
7	11490.00	62.9 PK	74.0	-11.1	1.18 V	90	42.50	20.40
8	11490.00	49.0 AV	54.0	-5.0	1.18 V	90	28.60	20.40

REMARKS:

1. Emission Level(dBuV/m) = Raw Value(dBuV) + Correction Factor(dB/m)
2. Correction Factor(dB/m) = Antenna Factor(dB/m) + Cable Factor(dB)
3. The other emission levels were very low against the limit.
4. Margin value = Emission Level – Limit value
5. " * ": Fundamental frequency.
6. " # ": The radiated frequency is out of the restricted band.

CHANNEL	TX Channel 157	DETECTOR FUNCTION	Peak (PK)
FREQUENCY RANGE	1GHz ~ 40GHz		Average (AV)

ANTENNA POLARITY & TEST DISTANCE: HORIZONTAL AT 3 M								
NO.	FREQ. (MHz)	EMISSION LEVEL (dBuV/m)	LIMIT (dBuV/m)	MARGIN (dB)	ANTENNA HEIGHT (m)	TABLE ANGLE (Degree)	RAW VALUE (dBuV)	CORRECTION FACTOR (dB/m)
1	5080.00	61.9 PK	74.0	-12.1	1.50 H	91	56.70	5.20
2	5080.00	52.5 AV	54.0	-1.5	1.50 H	91	47.30	5.20
3	*5785.00	115.4 PK			1.37 H	83	76.80	38.60
4	*5785.00	105.2 AV			1.37 H	83	66.60	38.60
5	11570.00	64.9 PK	74.0	-9.1	1.52 H	302	44.50	20.40
6	11570.00	50.3 AV	54.0	-3.7	1.52 H	302	29.90	20.40
ANTENNA POLARITY & TEST DISTANCE: VERTICAL AT 3 M								
NO.	FREQ. (MHz)	EMISSION LEVEL (dBuV/m)	LIMIT (dBuV/m)	MARGIN (dB)	ANTENNA HEIGHT (m)	TABLE ANGLE (Degree)	RAW VALUE (dBuV)	CORRECTION FACTOR (dB/m)
1	5080.00	56.3 PK	74.0	-17.7	1.23 V	300	51.10	5.20
2	5080.00	45.2 AV	54.0	-8.8	1.23 V	300	40.00	5.20
3	*5785.00	103.2 PK			1.45 V	16	64.60	38.60
4	*5785.00	93.1 AV			1.45 V	16	54.50	38.60
5	11570.00	63.3 PK	74.0	-10.7	1.12 V	29	42.90	20.40
6	11570.00	49.4 AV	54.0	-4.6	1.12 V	29	29.00	20.40

REMARKS:

1. Emission Level(dBuV/m) = Raw Value(dBuV) + Correction Factor(dB/m)
2. Correction Factor(dB/m) = Antenna Factor(dB/m) + Cable Factor(dB)
3. The other emission levels were very low against the limit.
4. Margin value = Emission Level – Limit value
5. " * ": Fundamental frequency.

CHANNEL	TX Channel 165	DETECTOR FUNCTION	Peak (PK)
FREQUENCY RANGE	1GHz ~ 40GHz		Average (AV)

ANTENNA POLARITY & TEST DISTANCE: HORIZONTAL AT 3 M								
NO.	FREQ. (MHz)	EMISSION LEVEL (dBuV/m)	LIMIT (dBuV/m)	MARGIN (dB)	ANTENNA HEIGHT (m)	TABLE ANGLE (Degree)	RAW VALUE (dBuV)	CORRECTION FACTOR (dB/m)
1	5080.00	61.8 PK	74.0	-12.2	1.49 H	88	56.60	5.20
2	5080.00	52.2 AV	54.0	-1.8	1.49 H	88	47.00	5.20
3	*5825.00	114.8 PK			1.36 H	86	76.10	38.70
4	*5825.00	104.6 AV			1.36 H	86	65.90	38.70
5	#5850.00	75.2 PK	78.2	-3.0	1.40 H	80	69.00	6.20
6	#5853.00	76.5 PK	78.2	-1.7	1.33 H	85	70.10	6.40
7	#5861.00	68.8 PK	74.0	-5.2	1.38 H	78	62.40	6.40
8	#5861.00	52.0 AV	54.0	-2.0	1.38 H	78	45.60	6.40
9	11650.00	63.7 PK	74.0	-10.3	1.37 H	133	43.40	20.30
10	11650.00	49.4 AV	54.0	-4.6	1.37 H	133	29.10	20.30

ANTENNA POLARITY & TEST DISTANCE: VERTICAL AT 3 M								
NO.	FREQ. (MHz)	EMISSION LEVEL (dBuV/m)	LIMIT (dBuV/m)	MARGIN (dB)	ANTENNA HEIGHT (m)	TABLE ANGLE (Degree)	RAW VALUE (dBuV)	CORRECTION FACTOR (dB/m)
1	5080.00	57.2 PK	74.0	-16.8	1.23 V	44	52.00	5.20
2	5080.00	46.2 AV	54.0	-7.8	1.23 V	44	41.00	5.20
3	*5825.00	101.8 PK			1.21 V	12	63.10	38.70
4	*5825.00	92.2 AV			1.21 V	12	53.50	38.70
5	#5850.00	61.7 PK	78.2	-16.5	1.10 V	359	55.50	6.20
6	#5853.00	60.4 PK	78.2	-17.8	1.19 V	26	54.00	6.40
7	#5861.00	55.9 PK	74.0	-18.1	1.30 V	38	49.50	6.40
8	#5861.00	45.3 AV	54.0	-8.7	1.30 V	38	38.90	6.40
9	11650.00	62.6 PK	74.0	-11.4	1.27 V	293	42.30	20.30
10	11650.00	49.0 AV	54.0	-5.0	1.27 V	293	28.70	20.30

REMARKS:

1. Emission Level(dBuV/m) = Raw Value(dBuV) + Correction Factor(dB/m)
2. Correction Factor(dB/m) = Antenna Factor(dB/m) + Cable Factor(dB)
3. The other emission levels were very low against the limit.
4. Margin value = Emission Level – Limit value
5. " * ": Fundamental frequency.
6. " # ": The radiated frequency is out of the restricted band.



A D T

802.11n (20MHz)

CHANNEL	TX Channel 149	DETECTOR FUNCTION	Peak (PK)
FREQUENCY RANGE	1GHz ~ 40GHz		Average (AV)

ANTENNA POLARITY & TEST DISTANCE: HORIZONTAL AT 3 M								
NO.	FREQ. (MHz)	EMISSION LEVEL (dBuV/m)	LIMIT (dBuV/m)	MARGIN (dB)	ANTENNA HEIGHT (m)	TABLE ANGLE (Degree)	RAW VALUE (dBuV)	CORRECTION FACTOR (dB/m)
1	#5714.00	66.1 PK	74.0	-7.9	1.40 H	71	60.10	6.00
2	#5714.00	48.9 AV	54.0	-5.1	1.40 H	71	42.90	6.00
3	#5722.00	76.9 PK	78.2	-1.3	1.41 H	103	70.90	6.00
4	#5725.00	68.1 PK	78.2	-10.1	1.39 H	102	62.10	6.00
5	*5745.00	112.1 PK			1.39 H	87	73.60	38.50
6	*5745.00	101.9 AV			1.39 H	87	63.40	38.50
7	11490.00	63.5 PK	74.0	-10.5	1.54 H	230	43.10	20.40
8	11490.00	49.4 AV	54.0	-4.6	1.54 H	230	29.00	20.40
ANTENNA POLARITY & TEST DISTANCE: VERTICAL AT 3 M								
NO.	FREQ. (MHz)	EMISSION LEVEL (dBuV/m)	LIMIT (dBuV/m)	MARGIN (dB)	ANTENNA HEIGHT (m)	TABLE ANGLE (Degree)	RAW VALUE (dBuV)	CORRECTION FACTOR (dB/m)
1	#5714.00	58.3 PK	74.0	-15.7	1.19 V	187	52.30	6.00
2	#5714.00	47.2 AV	54.0	-6.8	1.19 V	187	41.20	6.00
3	#5722.00	61.4 PK	78.2	-16.8	1.10 V	300	55.40	6.00
4	#5725.00	60.0 PK	78.2	-18.2	1.26 V	266	54.00	6.00
5	*5745.00	98.8 PK			1.21 V	16	60.30	38.50
6	*5745.00	89.0 AV			1.21 V	16	50.50	38.50
7	11490.00	62.6 PK	74.0	-11.4	1.24 V	30	42.20	20.40
8	11490.00	48.8 AV	54.0	-5.2	1.24 V	30	28.40	20.40

REMARKS:

1. Emission Level(dBuV/m) = Raw Value(dBuV) + Correction Factor(dB/m)
2. Correction Factor(dB/m) = Antenna Factor(dB/m) + Cable Factor(dB)
3. The other emission levels were very low against the limit.
4. Margin value = Emission Level – Limit value
5. " * ": Fundamental frequency.
6. " # ": The radiated frequency is out of the restricted band.

CHANNEL	TX Channel 157	DETECTOR FUNCTION	Peak (PK)
FREQUENCY RANGE	1GHz ~ 40GHz		Average (AV)

ANTENNA POLARITY & TEST DISTANCE: HORIZONTAL AT 3 M								
NO.	FREQ. (MHz)	EMISSION LEVEL (dBuV/m)	LIMIT (dBuV/m)	MARGIN (dB)	ANTENNA HEIGHT (m)	TABLE ANGLE (Degree)	RAW VALUE (dBuV)	CORRECTION FACTOR (dB/m)
1	5080.00	61.0 PK	74.0	-13.0	1.52 H	94	55.80	5.20
2	5080.00	52.8 AV	54.0	-1.2	1.52 H	94	47.60	5.20
3	*5785.00	116.1 PK			1.38 H	85	77.50	38.60
4	*5785.00	105.4 AV			1.38 H	85	66.80	38.60
5	11570.00	64.5 PK	74.0	-9.5	1.40 H	33	44.10	20.40
6	11570.00	50.0 AV	54.0	-4.0	1.40 H	33	29.60	20.40
ANTENNA POLARITY & TEST DISTANCE: VERTICAL AT 3 M								
NO.	FREQ. (MHz)	EMISSION LEVEL (dBuV/m)	LIMIT (dBuV/m)	MARGIN (dB)	ANTENNA HEIGHT (m)	TABLE ANGLE (Degree)	RAW VALUE (dBuV)	CORRECTION FACTOR (dB/m)
1	5080.00	57.6 PK	74.0	-16.4	1.09 V	323	52.40	5.20
2	5080.00	46.8 AV	54.0	-7.2	1.09 V	323	41.60	5.20
3	*5785.00	103.1 PK			1.21 V	14	64.50	38.60
4	*5785.00	93.0 AV			1.21 V	14	54.40	38.60
5	11570.00	63.2 PK	74.0	-10.8	1.20 V	111	42.80	20.40
6	11570.00	49.3 AV	54.0	-4.7	1.20 V	111	28.90	20.40

REMARKS:

1. Emission Level(dBuV/m) = Raw Value(dBuV) + Correction Factor(dB/m)
2. Correction Factor(dB/m) = Antenna Factor(dB/m) + Cable Factor(dB)
3. The other emission levels were very low against the limit.
4. Margin value = Emission Level – Limit value
5. " * ": Fundamental frequency.

CHANNEL	TX Channel 165	DETECTOR FUNCTION	Peak (PK)
FREQUENCY RANGE	1GHz ~ 40GHz		Average (AV)

ANTENNA POLARITY & TEST DISTANCE: HORIZONTAL AT 3 M								
NO.	FREQ. (MHz)	EMISSION LEVEL (dBuV/m)	LIMIT (dBuV/m)	MARGIN (dB)	ANTENNA HEIGHT (m)	TABLE ANGLE (Degree)	RAW VALUE (dBuV)	CORRECTION FACTOR (dB/m)
1	5080.00	60.2 PK	74.0	-13.8	1.48 H	84	55.00	5.20
2	5080.00	52.5 AV	54.0	-1.5	1.48 H	84	47.30	5.20
3	*5825.00	113.9 PK			1.40 H	84	75.20	38.70
4	*5825.00	103.5 AV			1.40 H	84	64.80	38.70
5	#5850.00	70.7 PK	78.2	-7.5	1.47 H	80	64.50	6.20
6	#5853.00	76.5 PK	78.2	-1.7	1.36 H	85	70.10	6.40
7	#5861.00	72.9 PK	74.0	-1.1	1.42 H	83	66.50	6.40
8	#5861.00	51.7 AV	54.0	-2.3	1.42 H	83	45.30	6.40
9	11650.00	63.1 PK	74.0	-10.9	1.43 H	93	42.80	20.30
10	11650.00	49.0 AV	54.0	-5.0	1.43 H	93	28.70	20.30

ANTENNA POLARITY & TEST DISTANCE: VERTICAL AT 3 M								
NO.	FREQ. (MHz)	EMISSION LEVEL (dBuV/m)	LIMIT (dBuV/m)	MARGIN (dB)	ANTENNA HEIGHT (m)	TABLE ANGLE (Degree)	RAW VALUE (dBuV)	CORRECTION FACTOR (dB/m)
1	5080.00	57.2 PK	74.0	-16.8	1.08 V	56	52.00	5.20
2	5080.00	46.0 AV	54.0	-8.0	1.08 V	56	40.80	5.20
3	*5825.00	101.4 PK			1.19 V	13	62.70	38.70
4	*5825.00	91.9 AV			1.19 V	13	53.20	38.70
5	#5850.00	68.7 PK	78.2	-9.5	1.20 V	198	62.50	6.20
6	#5853.00	60.6 PK	78.2	-17.6	1.22 V	22	54.20	6.40
7	#5861.00	60.9 PK	74.0	-13.1	1.30 V	358	54.50	6.40
8	#5861.00	49.2 AV	54.0	-4.8	1.30 V	358	42.80	6.40
9	11650.00	62.3 PK	74.0	-11.7	1.23 V	139	42.00	20.30
10	11650.00	48.5 AV	54.0	-5.5	1.23 V	139	28.20	20.30

REMARKS:

1. Emission Level(dBuV/m) = Raw Value(dBuV) + Correction Factor(dB/m)
2. Correction Factor(dB/m) = Antenna Factor(dB/m) + Cable Factor(dB)
3. The other emission levels were very low against the limit.
4. Margin value = Emission Level – Limit value
5. " * ": Fundamental frequency.
6. " # ": The radiated frequency is out of the restricted band.

802.11n (40MHz)

CHANNEL	TX Channel 151	DETECTOR FUNCTION	Peak (PK)
FREQUENCY RANGE	1GHz ~ 40GHz		Average (AV)

ANTENNA POLARITY & TEST DISTANCE: HORIZONTAL AT 3 M								
NO.	FREQ. (MHz)	EMISSION LEVEL (dBuV/m)	LIMIT (dBuV/m)	MARGIN (dB)	ANTENNA HEIGHT (m)	TABLE ANGLE (Degree)	RAW VALUE (dBuV)	CORRECTION FACTOR (dB/m)
1	#5714.00	69.5 PK	74.0	-4.5	1.45 H	79	63.50	6.00
2	#5714.00	52.2 AV	54.0	-1.8	1.45 H	79	46.20	6.00
3	#5723.00	73.0 PK	78.2	-5.2	1.44 H	100	67.00	6.00
4	#5725.00	73.4 PK	78.2	-4.8	1.41 H	102	67.40	6.00
5	*5755.00	106.2 PK			1.38 H	94	67.60	38.60
6	*5755.00	95.4 AV			1.38 H	94	56.80	38.60
7	11510.00	63.1 PK	74.0	-10.9	1.30 H	168	42.70	20.40
8	11510.00	48.9 AV	54.0	-5.1	1.30 H	168	28.50	20.40

ANTENNA POLARITY & TEST DISTANCE: VERTICAL AT 3 M								
NO.	FREQ. (MHz)	EMISSION LEVEL (dBuV/m)	LIMIT (dBuV/m)	MARGIN (dB)	ANTENNA HEIGHT (m)	TABLE ANGLE (Degree)	RAW VALUE (dBuV)	CORRECTION FACTOR (dB/m)
1	#5714.00	56.0 PK	74.0	-18.0	1.28 V	256	50.00	6.00
2	#5714.00	46.0 AV	54.0	-8.0	1.28 V	256	40.00	6.00
3	#5722.00	66.0 PK	78.2	-12.2	1.18 V	358	60.00	6.00
4	#5725.00	68.0 PK	78.2	-10.2	1.16 V	16	62.00	6.00
5	*5755.00	94.0 PK			1.21 V	15	55.40	38.60
6	*5755.00	84.3 AV			1.21 V	15	45.70	38.60
7	11510.00	62.1 PK	74.0	-11.9	1.20 V	108	41.70	20.40
8	11510.00	48.9 AV	54.0	-5.1	1.20 V	108	28.50	20.40

REMARKS:

1. Emission Level(dBuV/m) = Raw Value(dBuV) + Correction Factor(dB/m)
2. Correction Factor(dB/m) = Antenna Factor(dB/m) + Cable Factor(dB)
3. The other emission levels were very low against the limit.
4. Margin value = Emission Level – Limit value
5. " * ": Fundamental frequency.
6. " # ": The radiated frequency is out of the restricted band.

CHANNEL	TX Channel 159	DETECTOR FUNCTION	Peak (PK)
FREQUENCY RANGE	1GHz ~ 40GHz		Average (AV)

ANTENNA POLARITY & TEST DISTANCE: HORIZONTAL AT 3 M								
NO.	FREQ. (MHz)	EMISSION LEVEL (dBuV/m)	LIMIT (dBuV/m)	MARGIN (dB)	ANTENNA HEIGHT (m)	TABLE ANGLE (Degree)	RAW VALUE (dBuV)	CORRECTION FACTOR (dB/m)
1	5080.00	61.4 PK	74.0	-12.6	1.40 H	91	56.20	5.20
2	5080.00	52.4 AV	54.0	-1.6	1.40 H	91	47.20	5.20
3	*5795.00	112.2 PK			1.38 H	80	73.60	38.60
4	*5795.00	101.8 AV			1.38 H	80	63.20	38.60
5	#5850.00	72.3 PK	78.2	-5.9	1.39 H	108	66.10	6.20
6	#5855.00	73.9 PK	78.2	-4.3	1.39 H	93	67.50	6.40
7	#5861.00	72.6 PK	74.0	-1.4	1.39 H	85	66.20	6.40
8	#5861.00	51.9 AV	54.0	-2.1	1.39 H	85	45.50	6.40
9	11590.00	62.9 PK	74.0	-11.1	1.34 H	150	42.50	20.40
10	11590.00	49.2 AV	54.0	-4.8	1.34 H	150	28.80	20.40

ANTENNA POLARITY & TEST DISTANCE: VERTICAL AT 3 M								
NO.	FREQ. (MHz)	EMISSION LEVEL (dBuV/m)	LIMIT (dBuV/m)	MARGIN (dB)	ANTENNA HEIGHT (m)	TABLE ANGLE (Degree)	RAW VALUE (dBuV)	CORRECTION FACTOR (dB/m)
1	5080.00	60.2 PK	74.0	-13.8	1.28 V	19	55.00	5.20
2	5080.00	48.6 AV	54.0	-5.4	1.28 V	19	43.40	5.20
3	*5795.00	99.9 PK			1.43 V	16	61.30	38.60
4	*5795.00	89.9 AV			1.43 V	16	51.30	38.60
5	#5850.00	58.8 PK	78.2	-19.4	1.40 V	0	52.60	6.20
6	#5853.00	62.2 PK	78.2	-16.0	1.36 V	344	55.80	6.40
7	#5861.00	56.4 PK	74.0	-17.6	1.43 V	358	50.00	6.40
8	#5861.00	45.4 AV	54.0	-8.6	1.43 V	358	39.00	6.40
9	11590.00	62.3 PK	74.0	-11.7	1.14 V	69	41.90	20.40
10	11590.00	48.1 AV	54.0	-5.9	1.14 V	69	27.70	20.40

REMARKS:

1. Emission Level(dBuV/m) = Raw Value(dBuV) + Correction Factor(dB/m)
2. Correction Factor(dB/m) = Antenna Factor(dB/m) + Cable Factor(dB)
3. The other emission levels were very low against the limit.
4. Margin value = Emission Level – Limit value
5. " * ": Fundamental frequency.
6. " # ": The radiated frequency is out of the restricted band.

BELOW 1GHz WORST-CASE DATA

802.11n (20MHz)

CHANNEL	TX Channel 48	DETECTOR FUNCTION	Quasi-Peak (QP)
FREQUENCY RANGE	30MHz ~ 1GHz		

ANTENNA POLARITY & TEST DISTANCE: HORIZONTAL AT 3 M								
NO.	FREQ. (MHz)	EMISSION LEVEL (dBuV/m)	LIMIT (dBuV/m)	MARGIN (dB)	ANTENNA HEIGHT (m)	TABLE ANGLE (Degree)	RAW VALUE (dBuV)	CORRECTION FACTOR (dB/m)
1	57.12	32.2 QP	40.0	-7.8	1.99 H	201	46.80	-14.60
2	217.11	40.1 QP	46.0	-5.9	1.00 H	66	56.30	-16.20
3	226.27	43.9 QP	46.0	-2.1	1.49 H	78	60.20	-16.30
4	298.21	44.6 QP	46.0	-1.4	1.00 H	174	56.90	-12.30
5	498.47	32.0 QP	46.0	-14.0	1.49 H	16	40.30	-8.30
6	700.68	31.9 QP	46.0	-14.1	1.00 H	75	36.20	-4.30
ANTENNA POLARITY & TEST DISTANCE: VERTICAL AT 3 M								
NO.	FREQ. (MHz)	EMISSION LEVEL (dBuV/m)	LIMIT (dBuV/m)	MARGIN (dB)	ANTENNA HEIGHT (m)	TABLE ANGLE (Degree)	RAW VALUE (dBuV)	CORRECTION FACTOR (dB/m)
1	57.12	29.0 QP	40.0	-11.0	1.49 V	73	43.60	-14.60
2	214.61	30.7 QP	43.5	-12.8	1.49 V	153	46.90	-16.20
3	259.33	33.2 QP	46.0	-12.8	1.49 V	125	47.00	-13.80
4	298.77	42.6 QP	46.0	-3.4	1.00 V	121	54.90	-12.30
5	500.42	31.4 QP	46.0	-14.6	1.49 V	121	39.70	-8.30
6	700.68	33.7 QP	46.0	-12.3	1.00 V	96	38.00	-4.30

REMARKS:

1. Emission Level(dBuV/m) = Raw Value(dBuV) + Correction Factor(dB/m)
2. Correction Factor(dB/m) = Antenna Factor(dB/m) + Cable Factor(dB)
3. The other emission levels were very low against the limit.
4. Margin value = Emission Level – Limit value

4.2 CONDUCTED EMISSION MEASUREMENT

4.2.1 LIMITS OF CONDUCTED EMISSION MEASUREMENT

FREQUENCY OF EMISSION (MHz)	CONDUCTED LIMIT (dB μ V)	
	Quasi-peak	Average
0.15 ~ 0.5	66 to 56	56 to 46
0.5 ~ 5	56	46
5 ~ 30	60	50

- NOTE:**
1. The lower limit shall apply at the transition frequencies.
 2. The limit decreases in line with the logarithm of the frequency in the range of 0.15 to 0.50MHz.
 3. All emanations from a class A/B digital device or system, including any network of conductors and apparatus connected thereto, shall not exceed the level of field strengths specified above.

4.2.2 TEST INSTRUMENTS

DESCRIPTION & MANUFACTURER	MODEL NO.	SERIAL NO.	DATE OF CALIBRATION	DUE DATE OF CALIBRATION
Test Receiver ROHDE & SCHWARZ	ESCS30	100288	Apr. 24, 2014	Apr. 23, 2015
RF signal cable Woken	5D-FB	Cable-HYCO2-01	Dec. 27, 2013	Dec. 26, 2014
LISN ROHDE & SCHWARZ (EUT)	ESH2-Z5	100100	Dec. 23, 2013	Dec. 22, 2014
LISN ROHDE & SCHWARZ (Peripheral)	ESH3-Z5	100312	Jul. 10, 2014	Jul. 09, 2015
Software ADT	BV ADT_Cond_ V7.3.7.3	NA	NA	NA

- Notes:
1. The calibration interval of the above test instruments is 12 months and the calibrations are traceable to NML/ROC and NIST/USA.
 2. The test was performed in HwaYa Shielded Room 2.
 3. The VCCI Site Registration No. is C-2047.

4.2.3 TEST PROCEDURES

- a. The EUT was placed 0.4 meters from the conducting wall of the shielded room with EUT being connected to the power mains through a line impedance stabilization network (LISN). Other support units were connected to the power mains through another LISN. The two LISNs provide 50 ohm/ 50uH of coupling impedance for the measuring instrument.
- b. Both lines of the power mains connected to the EUT were checked for maximum conducted interference.
- c. The frequency range from 150kHz to 30MHz was searched. Emission levels under (Limit - 20dB) were not recorded.

NOTE: All modes of operation were investigated and the worst-case emissions are reported.

4.2.4 DEVIATION FROM TEST STANDARD

No deviation.

4.2.5 TEST SETUP

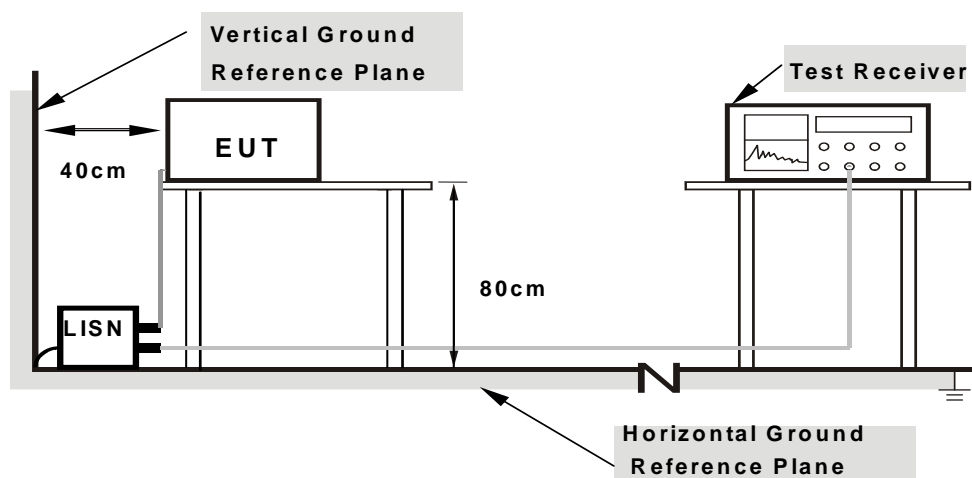

- Note:**
1. Support units were connected to second LISN.
 2. Both of LISNs (AMN) are 80 cm from EUT and at least 80 cm from other units and other metal planes

For the actual test configuration, please refer to the attached file (Test Setup Photo).

4.2.6 EUT OPERATING CONDITIONS

Same as 4.1.6.

4.2.7 TEST RESULTS

CONDUCTED WORST-CASE DATA: 802.11n (20MHz)

PHASE	Line 1	6dB BANDWIDTH	9kHz
-------	--------	---------------	------

No	Freq. [MHz]	Corr. Factor (dB)	Reading Value		Emission Level		Limit		Margin	
			[dB (uV)]		[dB (uV)]		[dB (uV)]		(dB)	
			Q.P.	AV.	Q.P.	AV.	Q.P.	AV.	Q.P.	AV.
1	0.22626	0.28	34.45	28.53	34.73	28.81	62.59	52.59	-27.85	-23.77
2	0.55234	0.31	36.92	32.25	37.23	32.56	56.00	46.00	-18.77	-13.44
3	0.66172	0.32	36.67	25.57	36.99	25.89	56.00	46.00	-19.01	-20.11
4	1.11719	0.34	32.86	23.05	33.20	23.39	56.00	46.00	-22.80	-22.61
5	4.43750	0.44	32.47	25.85	32.91	26.29	56.00	46.00	-23.09	-19.71
6	17.39453	0.56	36.74	31.65	37.30	32.21	60.00	50.00	-22.70	-17.79

REMARKS:

1. Q.P. and AV. are abbreviations of quasi-peak and average individually.
2. The emission levels of other frequencies were very low against the limit.
3. Margin value = Emission level - Limit value
4. Correction factor = Insertion loss + Cable loss
5. Emission Level = Correction Factor + Reading Value

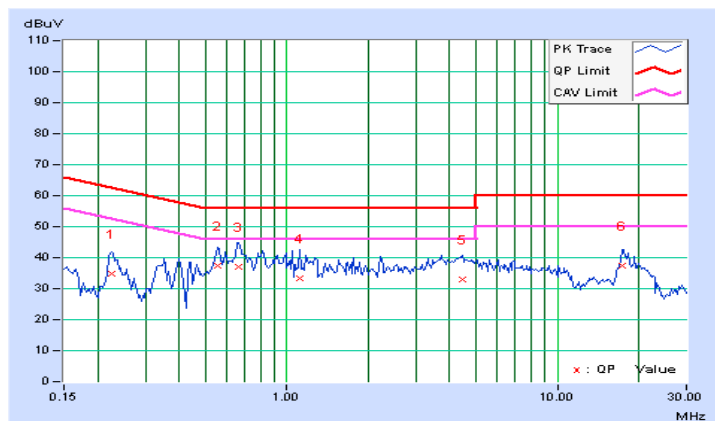

PHASE	Line 2	6dB BANDWIDTH	9kHz
-------	--------	---------------	------

No	Freq. [MHz]	Corr. Factor (dB)	Reading Value		Emission Level		Limit		Margin	
			[dB (uV)]		[dB (uV)]		[dB (uV)]		(dB)	
			Q.P.	AV.	Q.P.	AV.	Q.P.	AV.	Q.P.	AV.
1	0.34531	0.29	33.29	24.02	33.58	24.31	59.07	49.07	-25.49	-24.76
2	0.57188	0.31	35.87	24.99	36.18	25.30	56.00	46.00	-19.82	-20.70
3	0.66563	0.32	35.84	18.86	36.16	19.18	56.00	46.00	-19.84	-26.82
4	1.18359	0.35	32.46	19.92	32.81	20.27	56.00	46.00	-23.19	-25.73
5	3.96094	0.44	33.87	28.11	34.31	28.55	56.00	46.00	-21.69	-17.45
6	17.75781	0.61	36.91	31.59	37.52	32.20	60.00	50.00	-22.48	-17.80

REMARKS:

1. Q.P. and AV. are abbreviations of quasi-peak and average individually.
2. The emission levels of other frequencies were very low against the limit.
3. Margin value = Emission level - Limit value
4. Correction factor = Insertion loss + Cable loss
5. Emission Level = Correction Factor + Reading Value

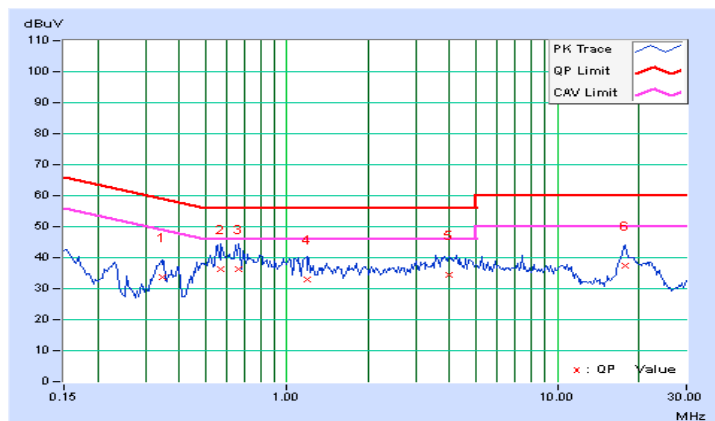

4.3 TRANSMIT POWER MEASUREMENT

4.3.1 LIMITS OF TRANSMIT POWER MEASUREMENT

Operation Band	EUT Category		LIMIT
U-NII-1		Outdoor Access Point	1 Watt (30 dBm) (Max. e.i.r.p 125mW(21 dBm) at any elevation angle above 30 degrees as measured from the horizon)
		Fixed point-to-point Access Point	1 Watt (30 dBm)
	√	Indoor Access Point	1 Watt (30 dBm)
		Mobile and Portable client device	250mW (24 dBm)
U-NII-2A		---	250mW (24 dBm) or 11 dBm+10 log B*
U-NII-2C		---	250mW (24 dBm) or 11 dBm+10 log B*
U-NII-3	√	---	1 Watt (30 dBm)

*B is the 26 dB emission bandwidth in megahertz

Per KDB 662911 D01 Multiple Transmitter Output v02r01 Method of conducted output power measurement on IEEE 802.11 devices,

Array Gain = 0 dB (i.e., no array gain) for NANT ≤ 4;

Array Gain = 0 dB (i.e., no array gain) for channel widths ≥ 40 MHz for any NANT;

Array Gain = 5 log(NANT/NSS) dB or 3 dB, whichever is less for 20-MHz channel widths with NANT ≥ 5.

For power measurements on all other devices: Array Gain = 10 log(NANT/NSS) dB.

4.3.2 TEST SETUP

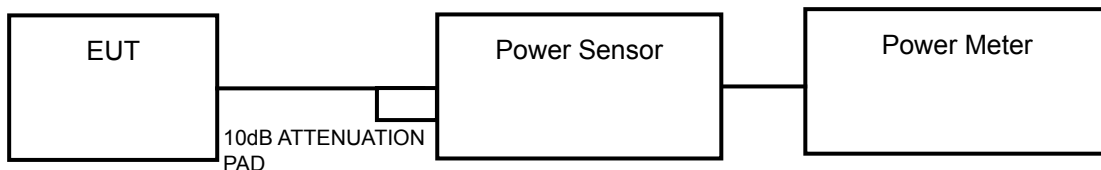

4.3.3 TEST INSTRUMENTS

Refer to section 4.1.3 to get information of above instrument.

4.3.4 TEST PROCEDURE

Method PM is used to perform output power measurement, trigger and gating function of wide band power meter is enabled to measure max output power of TX on burst. Duty factor is not added to measured value.

4.3.5 DEVIATION FROM TEST STANDARD

No deviation.

4.3.6 EUT OPERATING CONDITIONS

The software provided by client to enable the EUT under transmission condition continuously at specific channel frequencies individually.

4.3.7 TEST RESULTS

802.11a

CHAN.	FREQ. (MHz)	MAXIMUM CONDUCTED POWER (dBm)		TOTAL POWER (mW)	TOTAL POWER (dBm)	POWER LIMIT (dBm)	PASS / FAIL
		CHAIN 0	CHAIN 1				
36	5180	14.35	13.16	47.928	16.81	30	PASS
40	5200	17.21	16.73	99.700	19.99	30	PASS
48	5240	16.88	17.18	100.993	20.04	30	PASS
149	5745	12.80	13.37	40.782	16.10	29.80	PASS
157	5785	15.72	16.68	83.884	19.24	29.80	PASS
165	5825	15.81	16.81	86.080	19.35	29.80	PASS

Note: For U-NII-3 Band: Max gain = 6.2 > 6dBi, so the conducted power limit shall be reduced to 30-(6.2-6) = 29.80dBm.

802.11n (20MHz)

CHAN.	FREQ. (MHz)	MAXIMUM CONDUCTED POWER (dBm)		TOTAL POWER (mW)	TOTAL POWER (dBm)	POWER LIMIT (dBm)	PASS / FAIL
		CHAIN 0	CHAIN 1				
36	5180	14.55	13.83	52.665	17.22	30	PASS
40	5200	17.23	16.97	102.619	20.11	30	PASS
48	5240	17.24	17.71	111.986	20.49	30	PASS
149	5745	12.56	13.01	38.029	15.80	29.80	PASS
157	5785	15.62	16.63	82.501	19.16	29.80	PASS
165	5825	15.49	15.99	75.119	18.76	29.80	PASS

Note: For U-NII-3 Band: Max gain = 6.2 > 6dBi, so the conducted power limit shall be reduced to 30-(6.2-6) = 29.80dBm.



802.11n (40MHz)

CHAN.	FREQ. (MHz)	MAXIMUM CONDUCTED POWER (dBm)		TOTAL POWER (mW)	TOTAL POWER (dBm)	POWER LIMIT (dBm)	PASS / FAIL
		CHAIN 0	CHAIN 1				
38	5190	10.73	10.00	21.830	13.39	30	PASS
46	5230	16.44	16.67	90.507	19.57	30	PASS
151	5755	9.41	10.23	19.274	12.85	29.80	PASS
159	5795	16.01	16.63	85.928	19.34	29.80	PASS

Note: For U-NII-3 Band: Max gain = 6.2 > 6dBi, so the conducted power limit shall be reduced to $30 - (6.2 - 6) = 29.80\text{dBm}$.

4.4 PEAK POWER SPECTRAL DENSITY MEASUREMENT

4.4.1 LIMITS OF PEAK POWER SPECTRAL DENSITY MEASUREMENT

Operation Band	EUT Category		LIMIT
U-NII-1		Outdoor Access Point	17dBm/ MHz
		Fixed point-to-point Access Point	
	√	Indoor Access Point	
		Mobile and Portable client device	11dBm/ MHz
U-NII-2A		---	11dBm/ MHz
U-NII-2C		---	11dBm/ MHz
U-NII-3	√	---	30dBm/ MHz

4.4.2 TEST SETUP

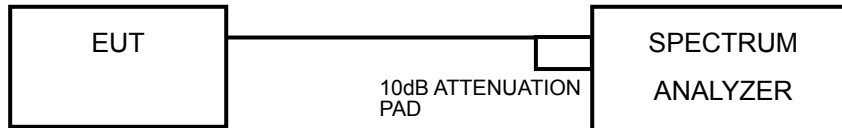

4.4.3 TEST INSTRUMENTS

Refer to section 4.1.3 to get information of above instrument.

4.4.4 TEST PROCEDURES

For U-NII-1 band:

Using method SA-2 alternative

- 1) Set span to encompass the entire emission bandwidth (EBW) of the signal.
- 2) Set RBW = 30 kHz, Set VBW \geq 1 MHz, Detector = RMS
- 3) Set Channel power measure = 1MHz
- 4) Sweep time = 30ms
- 5) Perform a single sweep.
- 6) Record the max value and add 10 log (1/duty cycle)

For U-NII-3 band:

- 1) Set span to encompass the entire emission bandwidth (EBW) of the signal.
- 2) Set RBW = 500 kHz, Set VBW \geq 3 RBW, Detector = RMS
- 3) Sweep time = auto, trigger set to "free run".
- 4) Trace average at least 100 traces in power averaging mode.
- 5) Record the max value and add $10 \log (1/\text{duty cycle})$

4.4.5 DEVIATION FROM TEST STANDARD

No deviation.

4.4.6 EUT OPERATING CONDITIONS

Same as 4.3.6.

4.4.7 TEST RESULTS

For U-NII-1 Band

802.11a

CHAN.	FREQ. (MHz)	PSD (dBm)		TOTAL PSD W/O DUTY FACTOR (dBm)	DUTY FACTOR	TOTAL PSD WITH DUTY FACTOR (dBm)	MAX. LIMIT (dBm)	PASS / FAIL
		CHAIN 0	CHAIN 1					
36	5180	1.37	0.00	3.74	0.15	3.89	14.29	PASS
40	5200	4.63	4.35	7.50	0.15	7.65	14.29	PASS
48	5240	4.35	4.42	7.39	0.15	7.54	14.29	PASS

NOTE:

1. Method 1 of power density measurement of KDB 662911 is using for calculating total power density. Total power density is summing entire spectra across corresponding frequency bins on the various outputs by computer.
2. Directional gain = $5.7\text{dBi} + 10\log(2) = 8.71\text{dBi} > 6\text{dBi}$, so the power density limit shall be reduced to $17-(8.71-6) = 14.29\text{dBm}$.
3. Refer to section 3.3 for duty cycle spectrum plot.

802.11n (20MHz)

CHAN.	FREQ. (MHz)	PSD (dBm)		TOTAL PSD W/O DUTY FACTOR (dBm)	DUTY FACTOR	TOTAL PSD WITH DUTY FACTOR (dBm)	MAX. LIMIT (dBm)	PASS / FAIL
		CHAIN 0	CHAIN 1					
36	5180	1.59	0.83	4.24	0.15	4.39	14.29	PASS
40	5200	4.53	4.33	7.45	0.15	7.60	14.29	PASS
48	5240	4.61	4.72	7.68	0.15	7.83	14.29	PASS

NOTE:

1. Method 1 of power density measurement of KDB 662911 is using for calculating total power density. Total power density is summing entire spectra across corresponding frequency bins on the various outputs by computer.
2. Directional gain = $5.7\text{dBi} + 10\log(2) = 8.71\text{dBi} > 6\text{dBi}$, so the power density limit shall be reduced to $17-(8.71-6) = 14.29\text{dBm}$.
3. Refer to section 3.3 for duty cycle spectrum plot.



A D T

802.11n (40MHz)

CHAN.	FREQ. (MHz)	PSD (dBm)		TOTAL PSD W/O DUTY FACTOR (dBm)	DUTY FACTOR	TOTAL PSD WITH DUTY FACTOR (dBm)	MAX. LIMIT (dBm)	PASS / FAIL
		CHAIN 0	CHAIN 1					
38	5190	-5.34	-6.69	-3.10	0.28	-2.67	14.29	PASS
46	5230	0.87	0.71	3.65	0.28	4.08	14.29	PASS

NOTE:

- Method 1 of power density measurement of KDB 662911 is using for calculating total power density. Total power density is summing entire spectra across corresponding frequency bins on the various outputs by computer.
- Directional gain = $5.7\text{dBi} + 10\log(2) = 8.71\text{dBi} > 6\text{dBi}$, so the power density limit shall be reduced to $17 - (8.71 - 6) = 14.29\text{dBm}$.
- Refer to section 3.3 for duty cycle spectrum plot.

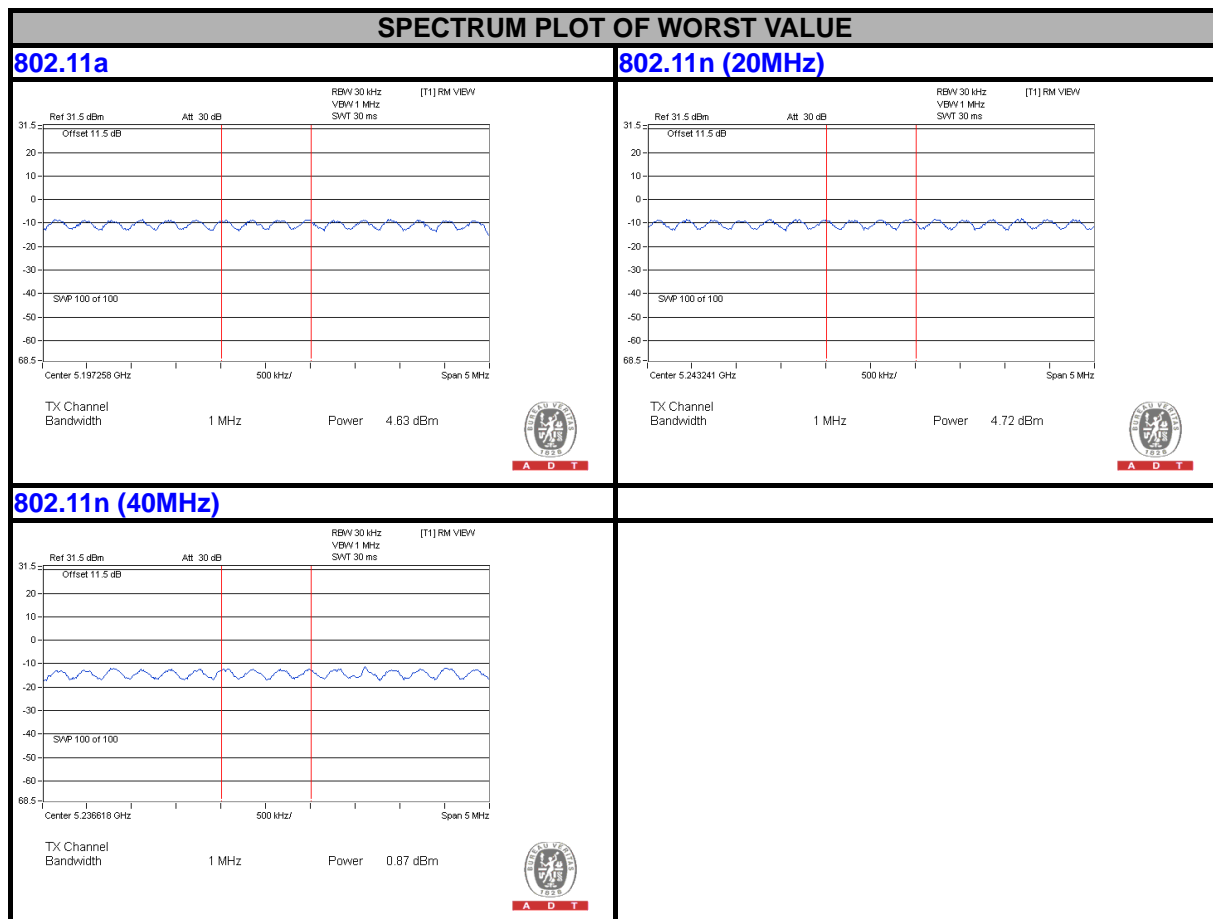

For U-NII-3 Band

802.11a

TX chain	Chan	Freq. (MHz)	PSD (dBm/500kHz)	10 log (N=2) dB	Total PSD without Duty Factor (dBm/500kHz)	Duty Factor	Total PSD with Duty Factor (dBm/ 500kHz)	Limit (dBm/ 500kHz)	PASS /FAIL
0	149	5745	7.91	3.01	10.92	0.15	11.07	26.79	PASS
	157	5785	9.95	3.01	12.96	0.15	13.11	26.79	PASS
	165	5825	9.83	3.01	12.84	0.15	12.99	26.79	PASS
1	149	5745	8.09	3.01	11.10	0.15	11.25	26.79	PASS
	157	5785	11.67	3.01	14.68	0.15	14.83	26.79	PASS
	165	5825	11.58	3.01	14.59	0.15	14.74	26.79	PASS

NOTE:

- Method 1 of power density measurement of KDB 662911 is using for calculating total power density. Total power density is summing entire spectra across corresponding frequency bins on the various outputs by computer.
- Directional gain = $6.2\text{dBi} + 10\log(2) = 9.21 > 6\text{dBi}$, so the power density limit shall be reduced to $30 - (9.21 - 6) = 26.79\text{dBm}$.
- Refer to section 3.3 for duty cycle spectrum plot.

802.11n (20MHz)

TX chain	Chan	Freq. (MHz)	PSD (dBm/500kHz)	10 log (N=2) dB	Total PSD without Duty Factor (dBm/500kHz)	Duty Factor	Total PSD with Duty Factor (dBm/ 500kHz)	Limit (dBm/ 500kHz)	PASS /FAIL
0	149	5745	6.34	3.01	9.35	0.15	9.50	26.79	PASS
	157	5785	9.52	3.01	12.53	0.15	12.68	26.79	PASS
	165	5825	9.04	3.01	12.05	0.15	12.20	26.79	PASS
1	149	5745	6.10	3.01	9.11	0.15	9.26	26.79	PASS
	157	5785	10.37	3.01	13.38	0.15	13.53	26.79	PASS
	165	5825	9.69	3.01	12.70	0.15	12.85	26.79	PASS

NOTE:

- Method 1 of power density measurement of KDB 662911 is using for calculating total power density. Total power density is summing entire spectra across corresponding frequency bins on the various outputs by computer.
- Directional gain = $6.2\text{dBi} + 10\log(2) = 9.21 > 6\text{dBi}$, so the power density limit shall be reduced to $30 - (9.21 - 6) = 26.79\text{dBm}$.
- Refer to section 3.3 for duty cycle spectrum plot.

802.11n (40MHz)

TX chain	Chan	Freq. (MHz)	PSD (dBm/500kHz)	10 log (N=2) dB	Total PSD without Duty Factor (dBm/500kHz)	Duty Factor	Total PSD with Duty Factor (dBm/ 500kHz)	Limit (dBm/ 500kHz)	PASS /FAIL
0	151	5755	0.63	3.01	3.64	0.28	3.92	26.79	PASS
	159	5795	7.23	3.01	10.24	0.28	10.52	26.79	PASS
1	151	5755	0.48	3.01	3.49	0.28	3.77	26.79	PASS
	159	5795	7.80	3.01	10.81	0.28	11.09	26.79	PASS

NOTE:

1. Method 1 of power density measurement of KDB 662911 is using for calculating total power density. Total power density is summing entire spectra across corresponding frequency bins on the various outputs by computer.
2. Directional gain = $6.2\text{dBi} + 10\log(2) = 9.21 > 6\text{dBi}$, so the power density limit shall be reduced to $30 - (9.21 - 6) = 26.79\text{dBm}$.
3. Refer to section 3.3 for duty cycle spectrum plot.

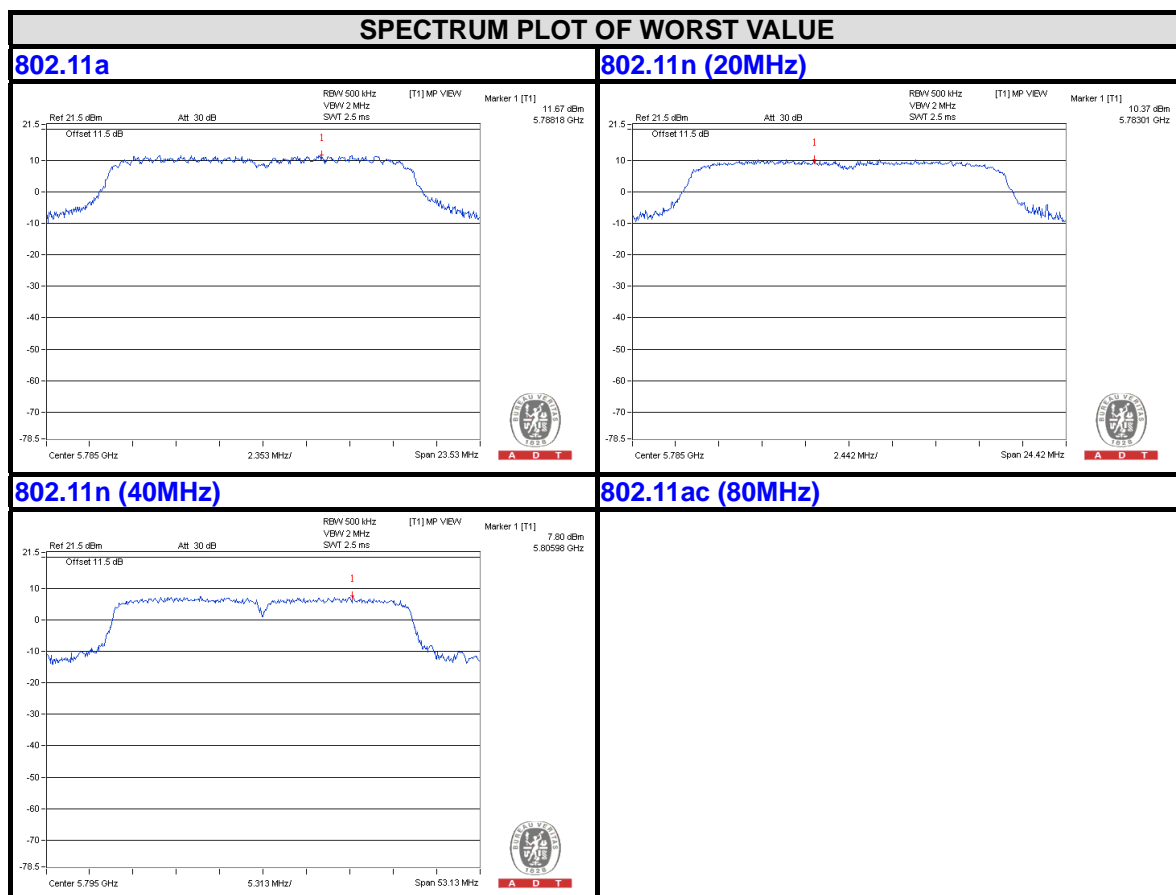

4.5 FREQUENCY STABILITY

4.5.1 LIMITS OF FREQUENCY STABILITY MEASUREMENT

The frequency of the carrier signal shall be maintained within band of operation

4.5.2 TEST SETUP

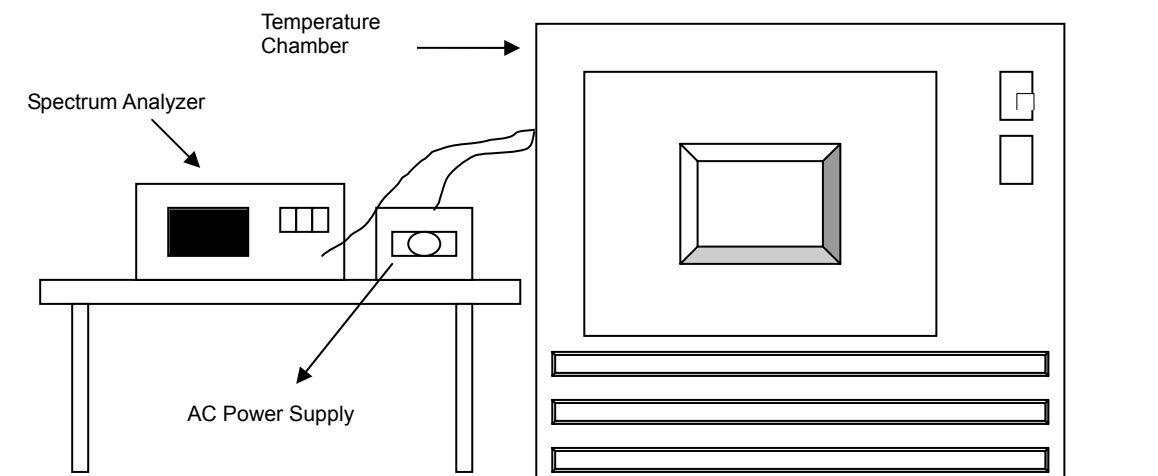

4.5.3 TEST INSTRUMENTS

Refer to section 4.1.3 to get information of above instrument.

4.5.4 TEST PROCEDURE

- a. The EUT was placed inside the environmental test chamber and powered by nominal AC voltage.
- b. Turn the EUT on and couple its output to a spectrum analyzer.
- c. Turn the EUT off and set the chamber to the highest temperature specified.
- d. Allow sufficient time (approximately 30 min) for the temperature of the chamber to stabilize, turn the EUT on and measure the operating frequency after 2, 5, and 10 minutes.
- e. Repeat step 2 and 3 with the temperature chamber set to the lowest temperature.
- f. The test chamber was allowed to stabilize at +20 degree C for a minimum of 30 minutes. The supply voltage was then adjusted on the EUT from 85% to 115% and the frequency record.

4.5.5 DEVIATION FROM TEST STANDARD

No deviation.

4.5.6 EUT OPERATING CONDITION

Set the EUT transmit at un-modulation mode to test frequency stability.

4.5.7 TEST RESULTS

FREQUENCY STABILITY VERSUS TEMP.									
OPERATING FREQUENCY: 5200MHz									
TEMP. ()	POWER SUPPLY (Vac)	0 MINUTE		2 MINUTE		5 MINUTE		10 MINUTE	
		Measured Frequency (MHz)	Frequency Drift (%)	Measured Frequency (MHz)	Frequency Drift (%)	Measured Frequency (MHz)	Frequency Drift (%)	Measured Frequency (MHz)	Frequency Drift (%)
50	120	5199.9890	-0.00021	5199.9875	-0.00024	5199.9897	-0.00020	5199.9887	-0.00022
40	120	5200.0077	0.00015	5200.0054	0.00010	5200.0084	0.00016	5200.0059	0.00011
30	120	5199.9940	-0.00012	5199.9908	-0.00018	5199.9925	-0.00014	5199.9914	-0.00017
20	120	5200.0204	0.00039	5200.0209	0.00040	5200.0186	0.00036	5200.0193	0.00037
10	120	5199.9875	-0.00024	5199.9871	-0.00025	5199.9886	-0.00022	5199.9863	-0.00026
0	120	5199.9847	-0.00029	5199.9843	-0.00030	5199.9837	-0.00031	5199.9858	-0.00027
-10	120	5199.9986	-0.00003	5199.9988	-0.00002	5199.9975	-0.00005	5199.9992	-0.00002
-20	120	5199.9874	-0.00024	5199.9878	-0.00023	5199.9896	-0.00020	5199.9883	-0.00023
-30	120	5200.0034	0.00007	5200.0020	0.00004	5200.0013	0.00002	5200.0008	0.00002

FREQUENCY STABILITY VERSUS TEMP.									
OPERATING FREQUENCY: 5240MHz									
TEMP. ()	POWER SUPPLY (Vac)	0 MINUTE		2 MINUTE		5 MINUTE		10 MINUTE	
		Measured Frequency (MHz)	Frequency Drift (%)	Measured Frequency (MHz)	Frequency Drift (%)	Measured Frequency (MHz)	Frequency Drift (%)	Measured Frequency (MHz)	Frequency Drift (%)
20	138	5200.0194	0.00037	5200.0204	0.00039	5200.0188	0.00036	5200.0200	0.00038
	120	5200.0204	0.00039	5200.0209	0.00040	5200.0186	0.00036	5200.0193	0.00037
	102	5200.0196	0.00038	5200.0205	0.00039	5200.0191	0.00037	5200.0197	0.00038

4.6 6dB BANDWIDTH MEASUREMENT

4.6.1 LIMITS OF 6dB BANDWIDTH MEASUREMENT

The minimum of 6dB Bandwidth Measurement is 0.5MHz.

4.6.2 TEST SETUP

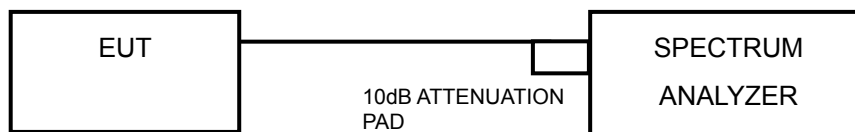

4.6.3 TEST INSTRUMENTS

Refer to section 4.1.2 to get information of above instrument.

4.6.4 TEST PROCEDURE

- a. Set resolution bandwidth (RBW) = 100kHz
- b. Set the video bandwidth (VBW) $\geq 3 \times$ RBW, Detector = Peak.
- c. Trace mode = max hold.
- d. Sweep = auto couple.
- e. Measure the maximum width of the emission that is constrained by the frequencies associated with the two amplitude points (upper and lower) that are attenuated by 6 dB relative to the maximum level measured in the fundamental emission

4.6.5 DEVIATION FROM TEST STANDARD

No deviation.

4.6.6 EUT OPERATING CONDITIONS

The software provided by client to enable the EUT under transmission condition continuously at lowest, middle and highest channel frequencies individually.

4.6.7 TEST RESULTS

802.11a

CHANNEL	FREQUENCY (MHz)	6dB BANDWIDTH (MHz)		MINIMUM LIMIT (MHz)	PASS / FAIL
		CHAIN 0	CHAIN 1		
149	5745	16.09	16.36	0.5	PASS
157	5785	15.71	15.69	0.5	PASS
165	5825	16.06	16.03	0.5	PASS

802.11n (20MHz)

CHANNEL	FREQUENCY (MHz)	6dB BANDWIDTH (MHz)		MINIMUM LIMIT (MHz)	PASS / FAIL
		CHAIN 0	CHAIN 1		
149	5745	17.10	16.75	0.5	PASS
157	5785	16.59	16.29	0.5	PASS
165	5825	16.57	16.93	0.5	PASS

802.11n (40MHz)

CHANNEL	FREQUENCY (MHz)	6dB BANDWIDTH (MHz)		MINIMUM LIMIT (MHz)	PASS / FAIL
		CHAIN 0	CHAIN 1		
151	5755	36.12	36.01	0.5	PASS
159	5795	35.52	35.42	0.5	PASS



A D T

SPECTRUM PLOT OF WORST VALUE

802.11a

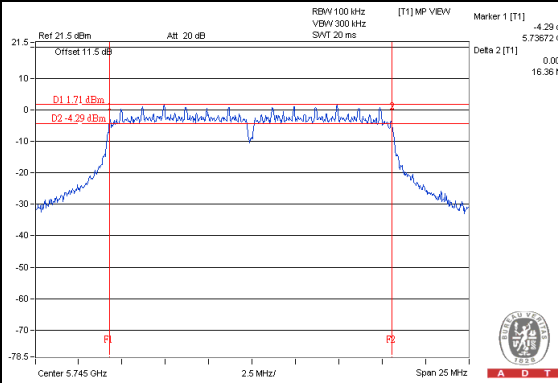

802.11n (20MHz)

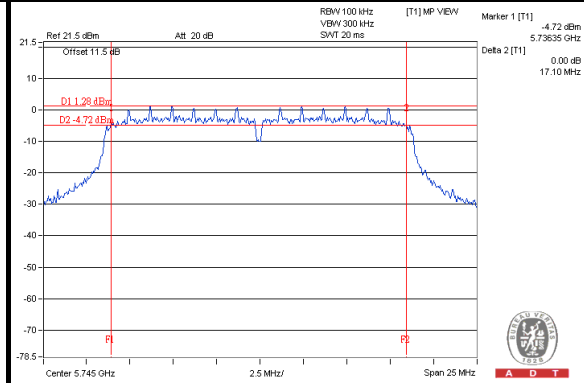

802.11n (40MHz)

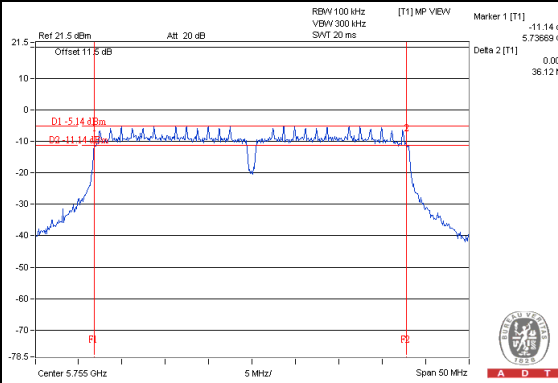

5. PHOTOGRAPHS OF THE TEST CONFIGURATION

Please refer to the attached file (Test Setup Photo).



6. INFORMATION ON THE TESTING LABORATORIES

We, Bureau Veritas Consumer Products Services (H.K.) Ltd., Taoyuan Branch, were founded in 1988 to provide our best service in EMC, Radio, Telecom and Safety consultation. Our laboratories are accredited and approved according to ISO/IEC 17025.

If you have any comments, please feel free to contact us at the following:

Linko EMC/RF Lab:

Tel: 886-2-26052180

Fax: 886-2-26051924

Hsin Chu EMC/RF Lab:

Tel: 886-3-5935343

Fax: 886-3-5935342

Hwa Ya EMC/RF/Safety Telecom Lab:

Tel: 886-3-3183232

Fax: 886-3-3270892

Email: service.adt@tw.bureauveritas.com

Web Site: www.bureauveritas-adt.com

The address and road map of all our labs can be found in our web site also.

7. APPENDIX A – MODIFICATIONS RECORDERS FOR ENGINEERING CHANGES TO THE EUT BY THE LAB

No modifications were made to the EUT by the lab during the test.

---END---