

FCC Test Report (Co-Located)

Report No.: RFBDYS-WTW-P22050651-2

FCC ID: Q6G-AP332CR

Test Model: AP332CR

Received Date: May 20, 2022

Test Date: Jul. 19, 2022

Issued Date: Sep. 02, 2022

Applicant: WatchGuard Technologies, Inc.

Address: 505 Fifth Avenue South, Suite 500 Seattle WA United States 98104

Issued By: Bureau Veritas Consumer Products Services (H.K.) Ltd., Taoyuan Branch
Lin Kou Laboratories

Lab Address: No. 47-2, 14th Ling, Chia Pau Vil., Lin Kou Dist., New Taipei City, Taiwan

Test Location (1): No. 19, Hwa Ya 2nd Rd., Wen Hwa Vil., Kewi Shan Dist., Taoyuan City
33383, Taiwan

FCC Registration /

Designation Number (1): 788550 / TW0003

Test Location (2): No. 70, Wenming Rd., Guishan Dist., Taoyuan City 333, Taiwan (R.O.C.)

FCC Registration /

Designation Number (2): 281270 / TW0032



This report is governed by, and incorporates by reference, the Conditions of Testing as posted at the date of issuance of this report at <http://www.bureauveritas.com/home/about-us/our-business/cps/about-us/terms-conditions/>, and is intended for your exclusive use. Any copying or replication of this report to or for any other person or entity, or use of our name or trademark, is permitted only with our prior written permission. This report sets forth our findings solely with respect to the test samples identified herein. The results set forth in this report are not indicative or representative of the quality or characteristics of the lot from which a test sample was taken or any similar or identical product unless specifically and expressly noted. Our report includes all of the tests requested by you and the results thereof based upon the information that you provided to us. Measurement uncertainty is only provided upon request for accredited tests. Statements of conformity are based on simple acceptance criteria without taking measurement uncertainty into account, unless otherwise requested in writing. You have 60 days from date of issuance of this report to notify us of any material error or omission caused by our negligence or if you require measurement uncertainty; provided, however, that such notice shall be in writing and shall specifically address the issue you wish to raise. A failure to raise such issue within the prescribed time shall constitute your unqualified acceptance of the completeness of this report, the tests conducted and the correctness of the report contents.

Table of Contents

Release Control Record	3
1 Certificate of Conformity	4
2 Summary of Test Results	5
2.1 Measurement Uncertainty	5
2.2 Modification Record	5
3 General Information	6
3.1 General Description of EUT	6
3.2 Description of Test Modes	9
3.2.1 Test Mode Applicability and Tested Channel Detail	11
3.3 Description of Support Units	12
3.3.1 Configuration of System under Test	12
3.4 General Description of Applied Standards	12
4 Test Types and Results	13
4.1 Radiated Emission and Bandedge Measurement	13
4.1.1 Limits of Radiated Emission and Bandedge Measurement	13
4.1.2 Test Instruments	14
4.1.3 Test Procedures	15
4.1.4 Deviation from Test Standard	15
4.1.5 Test Setup	16
4.1.6 EUT Operating Conditions	17
4.1.7 Test Results	18
5 Pictures of Test Arrangements	22
Appendix – Information of the Testing Laboratories	23

Release Control Record

Issue No.	Description	Date Issued
RFB DYS-WTW-P22050651-2	Original release	Sep. 02, 2022

1 Certificate of Conformity

Product: Wireless Access Point

Brand: WatchGuard

Test Model: AP332CR

Sample Status: Engineering sample

Applicant: WatchGuard Technologies, Inc.

Test Date: Jul. 19, 2022

Standards: 47 CFR FCC Part 15, Subpart C (Section 15.247)

47 CFR FCC Part 15, Subpart E (Section 15.407)

ANSI C63.10-2013

The above equipment has been tested by **Bureau Veritas Consumer Products Services (H.K.) Ltd., Taoyuan Branch**, and found compliance with the requirement of the above standards. The test record, data evaluation & Equipment Under Test (EUT) configurations represented herein are true and accurate accounts of the measurements of the sample's RF characteristics under the conditions specified in this report.

Prepared by : Pettie Chen , **Date:** Sep. 02, 2022
Pettie Chen / Senior Specialist

Approved by : Jeremy Lin , **Date:** Sep. 02, 2022
Jeremy Lin / Project Engineer

2 Summary of Test Results

Applied Standard:	47 CFR FCC Part 15, Subpart C (Section 15.247) 47 CFR FCC Part 15, Subpart E (Section 15.407)		
FCC Clause	Test Item	Result	Remarks
15.205 / 15.209 / 15.247(d) 15.407(b) (1/2/3/4(i/ii)/9)	Radiated Emissions	Pass	Meet the requirement of limit. Minimum passing margin is -0.5dB at 2390.00MHz.

Note: Determining compliance based on the results of the compliance measurement, not taking into account measurement instrumentation uncertainty.

2.1 Measurement Uncertainty

Where relevant, the following measurement uncertainty levels have been estimated for tests performed on the EUT as specified in CISPR 16-4-2:

Measurement	Frequency	Expanded Uncertainty (k=2) (±)
Radiated Emissions up to 1 GHz	9kHz ~ 30MHz	3.04 dB
	30MHz ~ 200MHz	3.86 dB
	200MHz ~ 1000MHz	3.87 dB
Radiated Emissions above 1 GHz	1GHz ~ 18GHz	2.29 dB
	18GHz ~ 40GHz	2.29 dB

2.2 Modification Record

There were no modifications required for compliance.

3 General Information

3.1 General Description of EUT

Product	Wireless Access Point	
Brand	WatchGuard	
Test Model	AP332CR	
Sample Status	Engineering sample	
Power Supply Rating	54Vdc (POE)	
Modulation Type	WLAN	CCK, DQPSK, DBPSK for DSSS 256QAM, 64QAM, 16QAM, QPSK, BPSK for OFDM 1024QAM, 256QAM, 64QAM, 16QAM, QPSK, BPSK for OFDMA
Modulation Technology	WLAN	DSSS, OFDM, OFDMA
Transfer Rate	WLAN	802.11b: 11.0/ 5.5/ 2.0/ 1.0Mbps 802.11g: 54.0/ 48.0/ 36.0/ 24.0/ 18.0/ 12.0/ 9.0/ 6.0Mbps 802.11a: 54/48/36/24/18/12/9/6Mbps 802.11n: up to 400Mbps (For 2.4G Band) 802.11n: up to 300Mbps (For 5G Band) 802.11ac: up to 867Mbps (For 5G Band) 802.11ax: up to 574Mbps (For 2.4G Band) 802.11ax: up to 1200Mbps (For 5G Band)
Operating Frequency	WLAN	2.4GHz: 2412 ~ 2462MHz 5.0GHz: 5180 ~ 5240MHz, 5260 ~ 5320MHz 5500 ~ 5720MHz, 5745 ~ 5825MHz
Number of Channel	WLAN	2412 ~ 2462MHz: 802.11b, 802.11g, 802.11n (HT20), 802.11ac (VHT20), 802.11ax (HE20): 11 802.11n (HT40), 802.11ac (VHT40), 802.11ax (HE40): 7 5180 ~ 5240MHz: 802.11a, 802.11n (HT20), 802.11ac (VHT20), 802.11ax (HE20): 4 802.11n (HT40), 802.11ac (VHT40), 802.11ax (HE40): 2 802.11ac (VHT80), 802.11ax (HE80): 1 5260 ~ 5320MHz: 802.11a, 802.11n (HT20), 802.11ac (VHT20), 802.11ax (HE20): 4 802.11n (HT40), 802.11ac (VHT40), 802.11ax (HE40): 2 802.11ac (VHT80), 802.11ax (HE80): 1

Number of Channel	WLAN	5500 ~ 5720MHz: 802.11a, 802.11n (HT20), 802.11ac (VHT20), 802.11ax (HE20): 12 802.11n (HT40), 802.11ac (VHT40), 802.11ax (HE40): 6 802.11ac (VHT80), 802.11ax (HE80): 2 5745 ~ 5825MHz: 802.11a, 802.11n (HT20), 802.11ac (VHT20), 802.11ax (HE20): 5 802.11n (HT40), 802.11ac (VHT40), 802.11ax (HE40): 2 802.11ac (VHT80), 802.11ax (HE80): 1
Output Power	WLAN	CDD Mode: 2412 ~ 2462MHz: 374.350mW 5180 ~ 5240MHz: 44.745mW 5260 ~ 5320MHz: 234.497mW 5500 ~ 5720MHz: 234.546mW 5745 ~ 5825MHz: 477.665mW Beamforming Mode: 2412 ~ 2462MHz: 337.798mW 5180 ~ 5240MHz: 21.952mW 5260 ~ 5320MHz: 147.476mW 5500 ~ 5720MHz: 147.254mW 5745 ~ 5825MHz: 476.083mW
Antenna Type	WLAN	Refer to note
Antenna Connector	WLAN	Refer to note
Accessory Device	NA	
Cable Supplied	1.75m non-shielded ground cable without core	

Note:

1. This report is issued as a supplementary report to the original BV CPS report no.: RF200513C01-3. The differences compared with the original report are changing product name and adding 5.26GHz to 5.32GHz and 5.50GHz to 5.720GHz by software.

2. The EUT incorporates a MIMO function. Physically, the EUT provides 2 completed transmitters and 2 receivers.

Band	Modulation Mode	Beamforming Mode	TX Function
2.4GHz Band	802.11b	Not Support	2TX
	802.11g	Not Support	2TX
	802.11n (HT20)	Support	2TX
	802.11n (HT40)	Support	2TX
	802.11n (VHT20)	Support	2TX
	802.11n (VHT40)	Support	2TX
	802.11ax (HE20)	Support	2TX
	802.11ax (HE40)	Support	2TX
5GHz Band	802.11a	Not Support	2TX
	802.11n (HT20)	Support	2TX
	802.11n (HT40)	Support	2TX
	802.11ac (VHT20)	Support	2TX
	802.11ac (VHT40)	Support	2TX
	802.11ac (VHT80)	Support	2TX
	802.11ax (HE20)	Support	2TX
	802.11ax (HE40)	Support	2TX
	802.11ax (HE80)	Support	2TX

* The bandwidth and modulation are similar for HT20/HT40/VHT20/VHT40 on 802.11n mode and HE20/HE40 on 802.11ax mode. Therefore the investigated worst case is the representative mode in test report. (Final test mode refer section 3.2.1)

3. The EUT consumes power from the following PoE (support unit only).

Brand	EnGenius
Model	EPA5006GP
Input Power	100-240Vac, 0.8A, 50-60Hz
Output Power	54Vdc, 0.6A PIN 4,5: 54Vdc
Power Line	0.5m non-shielded AC power cable without core

4. There are 2 radios for the EUT.

Radio	Function	TX/RX Function
1	WLAN 2.4G	2TX / 2RX
2	WLAN 5G	2TX / 2RX

5. The EUT with follow antennas gain is listed as table below.

Ant. Type	Dipole			
Connector	RP-SMA			
Gain (dBi)				
Frequency (MHz)	2400 ~ 2483.5MHz	5150~5350MHz	5470~5725MHz	5715~5850MHz
Ant. 1	5.17	-	-	-
Ant. 2	5.17	-	-	-
Ant. 3	-	5.12	5.17	5.17
Ant. 4	-	5.12	5.17	5.17

* Detail antenna specification please refer to antenna datasheet and/or antenna measurement report.

6. 2.4GHz (Radio 1) & 5GHz (Radio 2) technology can transmit at same time.

3.2 Description of Test Modes

For 2.4GHz

11 channels are provided for 802.11b, 802.11g, 802.11n (HT20), 802.11n (VHT20), 802.11ax (HE20):

Channel	Frequency	Channel	Frequency
1	2412MHz	7	2442MHz
2	2417MHz	8	2447MHz
3	2422MHz	9	2452MHz
4	2427MHz	10	2457MHz
5	2432MHz	11	2462MHz
6	2437MHz		

7 channels are provided for 802.11n (HT40), 802.11n (VHT40), 802.11ax (HE40):

Channel	Frequency	Channel	Frequency
3	2422MHz	7	2442MHz
4	2427MHz	8	2447MHz
5	2432MHz	9	2452MHz
6	2437MHz		

For 5180 ~ 5240MHz:

4 channels are provided for 802.11a, 802.11n (HT20), 802.11ac (VHT20), 802.11ax (HE20):

Channel	Frequency	Channel	Frequency
36	5180 MHz	44	5220 MHz
40	5200 MHz	48	5240 MHz

2 channels are provided for 802.11n (HT40), 802.11ac (VHT40), 802.11ax (HE40):

Channel	Frequency	Channel	Frequency
38	5190 MHz	46	5230 MHz

1 channel is provided for 802.11ac (VHT80), 802.11ax (HE80):

Channel	Frequency
42	5210MHz

For 5260 ~ 5320 MHz

4 channels are provided for 802.11a, 802.11n (HT20), 802.11ac (VHT20) and 802.11ax (HE20):

Channel	Frequency	Channel	Frequency
52	5260 MHz	60	5300 MHz
56	5280 MHz	64	5320 MHz

2 channels are provided for 802.11n (HT40), 802.11ac (VHT40) and 802.11ax (HE40):

Channel	Frequency	Channel	Frequency
54	5270 MHz	62	5310 MHz

1 channel is provided for 802.11ac (VHT80) and 802.11ax (HE80):

Channel	Frequency
58	5290 MHz

For 5500 ~ 5720 MHz

12 channels are provided for 802.11a, 802.11n (HT20), 802.11ac (VHT20) and 802.11ax (HE20):

Channel	Frequency	Channel	Frequency
100	5500 MHz	124	5620 MHz
104	5520 MHz	128	5640 MHz
108	5540 MHz	132	5660 MHz
112	5560 MHz	136	5680 MHz
116	5580 MHz	140	5700 MHz
120	5600 MHz	144	5720 MHz

6 channels are provided for 802.11n (HT40), 802.11ac (VHT40) and 802.11ax (HE40):

Channel	Frequency	Channel	Frequency
102	5510 MHz	126	5630 MHz
110	5550 MHz	134	5670 MHz
118	5590 MHz	142	5710 MHz

3 channels are provided for 802.11ac (VHT80) and 802.11ax (HE80):

Channel	Frequency	Channel	Frequency
106	5530 MHz	138	5690 MHz
122	5610 MHz		

For 5745 ~ 5825MHz:

5 channels are provided for 802.11a, 802.11n (HT20), 802.11ac (VHT20), 802.11ax (HE20):

Channel	Frequency	Channel	Frequency
149	5745MHz	161	5805MHz
153	5765MHz	165	5825MHz
157	5785MHz		

2 channels are provided for 802.11n (HT40), 802.11ac (VHT40), 802.11ax (HE40):

Channel	Frequency	Channel	Frequency
151	5755MHz	159	5795MHz

1 channel is provided for 802.11ac (VHT80), 802.11ax (HE80):

Channel	Frequency
155	5775MHz

3.2.1 Test Mode Applicability and Tested Channel Detail

EUT Configure Mode	Applicable to		Description
	RE \geq 1G	RE<1G	
-	√	√	-

Where RE \geq 1G: Radiated Emission above 1GHz & Bandedge Measurement
 RE<1G: Radiated Emission below 1GHz
 OB: Conducted Out-Band Emission Measurement

Note: The EUT had been pre-tested on the positioned of each 3 axis. The worst case was found when positioned on **Z-plane**.

Radiated Emission Test (Above 1GHz):

- Pre-Scan has been conducted to determine the worst-case mode from all possible combinations between available modulations, data rates and antenna ports (if EUT with antenna diversity architecture).
- Following channel(s) was (were) selected for the final test as listed below.

EUT Configure Mode	Mode	Freq. Range (MHz)	Available Channel	Tested Channel	Modulation Technology
-	802.11ax (HE20) + 802.11a +	2412 ~ 2462	1 to 11	6 + 144	OFDMA
		5260 ~ 5320	52 to 64		OFDM
		5500 ~ 5720	100 to 144		OFDM

Radiated Emission Test (Below 1GHz):

- Pre-Scan has been conducted to determine the worst-case mode from all possible combinations between available modulations, data rates and antenna ports (if EUT with antenna diversity architecture).
- Following channel(s) was (were) selected for the final test as listed below.

EUT Configure Mode	Mode	Freq. Range (MHz)	Available Channel	Tested Channel	Modulation Technology
-	802.11ax (HE20) + 802.11a +	2412 ~ 2462	1 to 11	6 + 144	OFDMA
		5260 ~ 5320	52 to 64		OFDM
		5500 ~ 5720	100 to 144		OFDM

Test Condition:

Applicable to	Environmental Conditions	Input Power (System)	Tested by
RE \geq 1G	26 deg. C, 64% RH	120Vac, 60Hz	Tim Chen
RE<1G	24 deg. C, 72% RH	120Vac, 60Hz	Tim Chen

3.3 Description of Support Units

The EUT has been tested as an independent unit together with other necessary accessories or support units. The following support units or accessories were used to form a representative test configuration during the tests.

ID	Product	Brand	Model No.	Serial No.	FCC ID	Remarks
A.	Notebook	DELL	E5410	1HC2XM1	FCC DoC Approved	-
B.	PoE	EnGenius	EPA5006GP	NA	NA	Provided by client

Note:

1. All power cords of the above support units are non-shielded (1.8m).
2. Item A acted as a communication partner to transfer data.

ID	Cable Descriptions	Qty.	Length (m)	Shielding (Yes/No)	Cores (Qty.)	Remarks
1.	LAN cable	1	1.5	N	0	RJ45, Cat5e
2.	LAN cable	1	7	N	0	RJ45, Cat5e
3.	Ground cable	1	1.75	N	0	Accessory of EUT

3.3.1 Configuration of System under Test

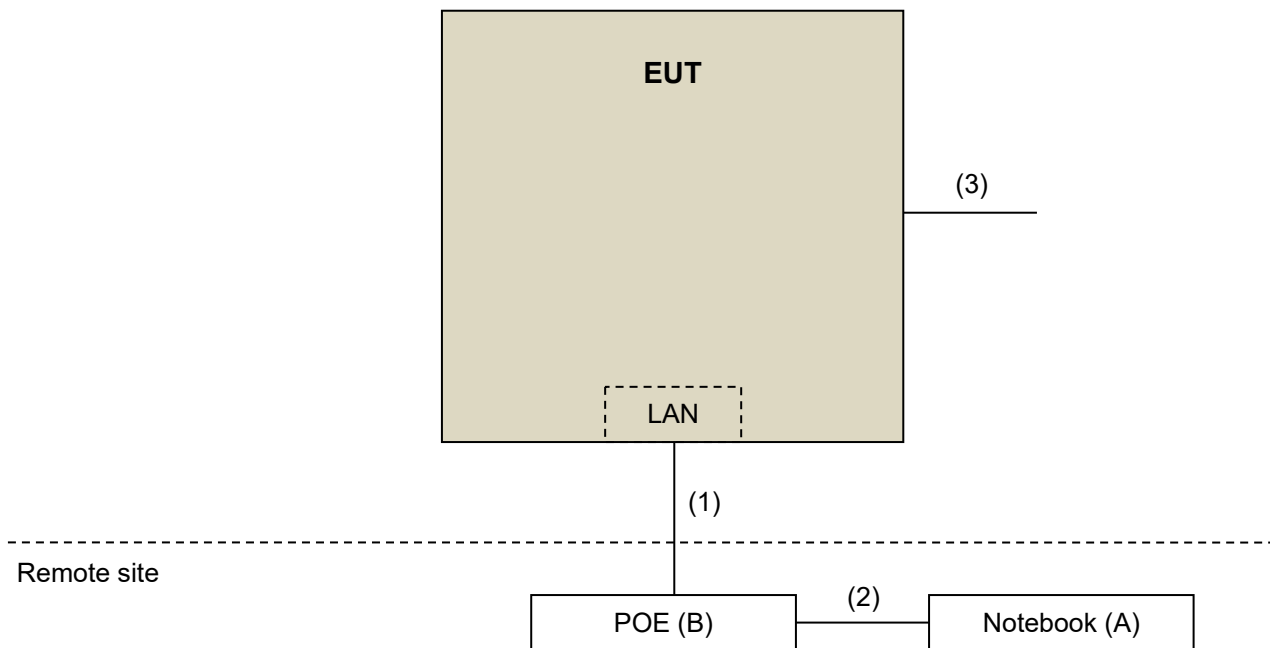

3.4 General Description of Applied Standards

The EUT is a RF Product. According to the specification of the EUT declared by the manufacturer, it must comply with the requirements of the following standards:

FCC Part 15, Subpart C (15.247)

FCC Part 15, Subpart E (15.407)

ANSI C63.10-2013

All test items have been performed and recorded as per the above standards.

4 Test Types and Results

4.1 Radiated Emission and Bandedge Measurement

4.1.1 Limits of Radiated Emission and Bandedge Measurement

Radiated emissions which fall in the restricted bands must comply with the radiated emission limits specified as below table. Other emissions shall be at least 30dB below the highest level of the desired power:

Frequencies (MHz)	Field Strength (microvolts/meter)	Measurement Distance (meters)
0.009 ~ 0.490	2400/F(kHz)	300
0.490 ~ 1.705	24000/F(kHz)	30
1.705 ~ 30.0	30	30
30 ~ 88	100	3
88 ~ 216	150	3
216 ~ 960	200	3
Above 960	500	3

Note:

1. The lower limit shall apply at the transition frequencies.
2. Emission level (dBuV/m) = 20 log Emission level (uV/m).
3. For frequencies above 1000MHz, the field strength limits are based on average detector, however, the peak field strength of any emission shall not exceed the maximum permitted average limits, specified above by more than 20dB under any condition of modulation.

Limits of unwanted emission out of the restricted bands

Applicable To		Limit	
789033 D02 General UNII Test Procedure New Rules v02r01		Field Strength at 3m	
		PK: 74 (dBµV/m)	AV: 54 (dBµV/m)
Frequency Band	Applicable To	EIRP Limit	Equivalent Field Strength at 3m
5150~5250 MHz	15.407(b)(1)	PK: -27 (dBm/MHz)	PK: 68.2(dBµV/m)
5250~5350 MHz	15.407(b)(2)		
5470~5725 MHz	15.407(b)(3)		
5725~5850 MHz	<input checked="" type="checkbox"/> 15.407(b)(4)(i)	PK: -27 (dBm/MHz) ^{*1} PK: 10 (dBm/MHz) ^{*2} PK: 15.6 (dBm/MHz) ^{*3} PK: 27 (dBm/MHz) ^{*4}	PK: 68.2(dBµV/m) ^{*1} PK: 105.2 (dBµV/m) ^{*2} PK: 110.8(dBµV/m) ^{*3} PK: 122.2 (dBµV/m) ^{*4}
	<input type="checkbox"/> 15.407(b)(4)(ii)	Emission limits in section 15.247(d)	
^{*1} beyond 75 MHz or more above of the band edge.		^{*2} below the band edge increasing linearly to 10 dBm/MHz at 25 MHz above.	
^{*3} below the band edge increasing linearly to a level of 15.6 dBm/MHz at 5 MHz above.		^{*4} from 5 MHz above or below the band edge increasing linearly to a level of 27 dBm/MHz at the band edge.	

Note: The following formula is used to convert the equipment isotropic radiated power (eirp) to field strength:

$$E = \frac{1000000\sqrt{30P}}{3} \mu\text{V/m, where P is the eirp (Watts).}$$

4.1.2 Test Instruments

Description & Manufacturer	Model No.	Serial No.	Cal. Date	Cal. Due
Antenna Tower Max-Full	MFT-151SS-0.5T	N/A	N/A	N/A
Bi-log Broadband Antenna Schwarzbeck	VULB9168	9168-1213	2021/10/27	2022/10/26
Loop Antenna TESEQ	HLA 6121	45745	2021/7/21	2022/7/20
Loop Antenna EMCI	EM-6879	269	2021/9/16	2022/9/15
Pre_Amplifier EMCI	EMC330N	980782	2022/1/17	2023/1/16
Pre_Amplifier EMCI	EMC118A45SE	980808	2021/12/30	2022/12/29
Pre_Amplifier EMCI	EMC184045SE	980788	2022/1/17	2023/1/16
Pre-amplifier EMCI	EMC001340	980201	2021/9/15	2022/9/14
Horn Antenna RFSPIN	DRH18-E	210103A18E	2021/11/14	2022/11/13
Horn Antenna Schwarzbeck	BBHA 9170	9170-1049	2021/11/14	2022/11/13
RF Coaxial Cable EMCI	5D-NM-BM	140903+140902	2022/1/15	2023/1/14
	EMCCFD400-NM-NM-500	201233	2022/1/17	2023/1/16
	EMCCFD400-NM-NM-3000	201235	2022/1/17	2023/1/16
	EMCCFD400-NM-NM-9000	201236	2022/1/17	2023/1/16
	EMC104-SM-SM-1000	210102	2022/1/17	2023/1/16
	EMC104-SM-SM-3000	201231	2022/1/17	2023/1/16
	EMC104-SM-SM-9000	201243	2022/1/17	2023/1/16
	EMC101G-KM-KM-5000	201260	2022/1/17	2023/1/16
	EMC101G-KM-KM-3000	201257	2022/1/17	2023/1/16
EMC101G-KM-KM-2000	201254	2022/1/17	2023/1/16	
Software BV ADT	ADT_Radiated_ V7.6.15.9.5	N/A	N/A	N/A
Spectrum Analyzer R&S	FSW43	101866	2022/1/14	2023/1/13
Test Receiver R&S	ESR3+	102782	2021/12/10	2022/12/9
Turn Table Max-Full	MF-7802BS	N/A	N/A	N/A
Turn Table Controller Max-Full	MF-7802BS	MF780208674	N/A	N/A

Note: 1. The calibration interval of the above test instruments is 12 months and the calibrations are traceable to NML/ROC and NIST/USA.
2. The test was performed in WM - 966 chamber 8.

4.1.3 Test Procedures

For Radiated emission below 30MHz

- a. The EUT was placed on the top of a rotating table 0.8 meters above the ground at a 3 meter chamber room. The table was rotated 360 degrees to determine the position of the highest radiation.
- b. The EUT was set 3 meters away from the interference-receiving antenna, which was mounted on the top of a variable-height antenna tower.
- c. Parallel, perpendicular, and ground-parallel orientations of the antenna are set to make the measurement.
- d. For each suspected emission, the EUT was arranged to its worst case and the rotatable table was turned from 0 degrees to 360 degrees to find the maximum reading.
- e. The test-receiver system was set to Quasi-Peak Detect Function and Specified Bandwidth with Maximum Hold Mode.

Note:

1. The resolution bandwidth and video bandwidth of test receiver/spectrum analyzer is 9kHz at frequency below 30MHz.

For Radiated emission above 30MHz

- a. The EUT was placed on the top of a rotating table 0.8 meters (for 30MHz ~ 1GHz) / 1.5 meters (for above 1GHz) above the ground at 3 meter chamber room for test. The table was rotated 360 degrees to determine the position of the highest radiation.
- b. The EUT was set 3 meters away from the interference-receiving antenna, which was mounted on the top of a variable-height antenna tower.
- c. The height of antenna is varied from one meter to four meters above the ground to determine the maximum value of the field strength. Both horizontal and vertical polarizations of the antenna are set to make the measurement.
- d. For each suspected emission, the EUT was arranged to its worst case and then the antenna was tuned to heights from 1 meter to 4 meters and the rotatable table was turned from 0 degrees to 360 degrees to find the maximum reading.
- e. The test-receiver system was set to quasi-peak detect function and specified bandwidth with maximum hold mode when the test frequency is below 1 GHz.
- f. The test-receiver system was set to peak and average detect function and specified bandwidth with maximum hold mode when the test frequency is above 1 GHz. If the peak reading value also meets average limit, measurement with the average detector is unnecessary.

Note:

1. The resolution bandwidth and video bandwidth of test receiver/spectrum analyzer is 120kHz for Quasi-peak detection (QP) at frequency below 1GHz.
2. The resolution bandwidth of test receiver/spectrum analyzer is 1 MHz and the video bandwidth is 3 MHz for Peak detection (PK) at frequency above 1GHz.
3. The resolution bandwidth of test receiver/spectrum analyzer is 1MHz and the video bandwidth is $\geq 1/T$ (Duty cycle < 98%) or 10Hz (Duty cycle $\geq 98\%$) for Average detection (AV) at frequency above 1GHz.
4. All modes of operation were investigated and the worst-case emissions are reported.

4.1.4 Deviation from Test Standard

No deviation.

4.1.5 Test Setup

For Radiated emission below 30MHz

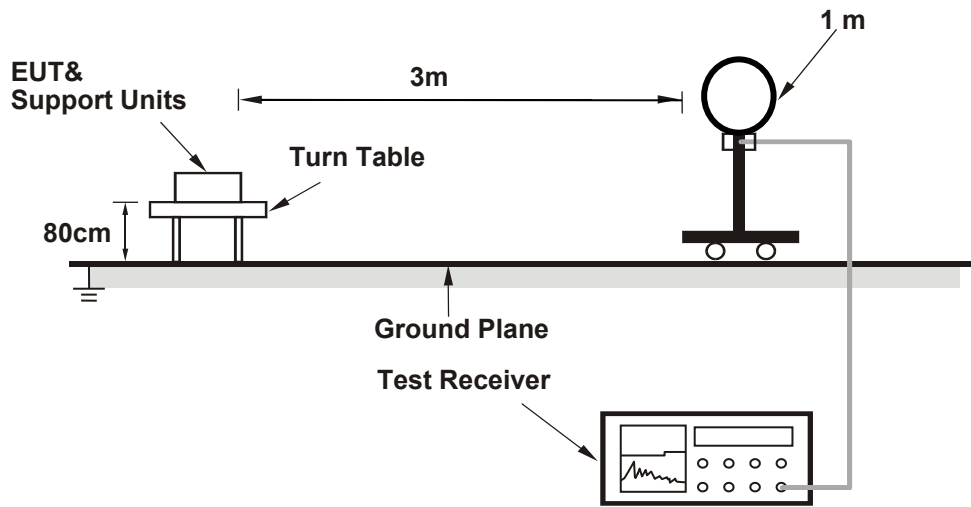

For Radiated emission 30MHz to 1GHz

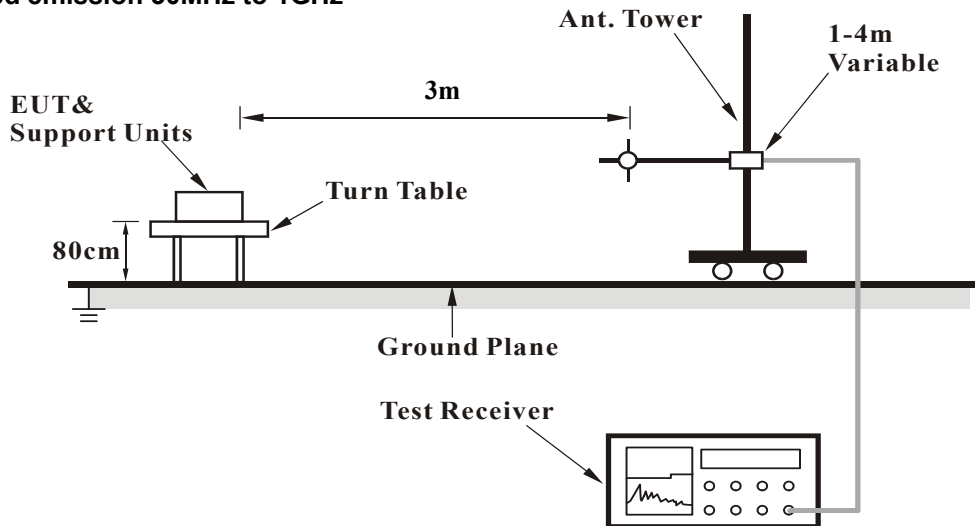

For Radiated emission above 1GHz

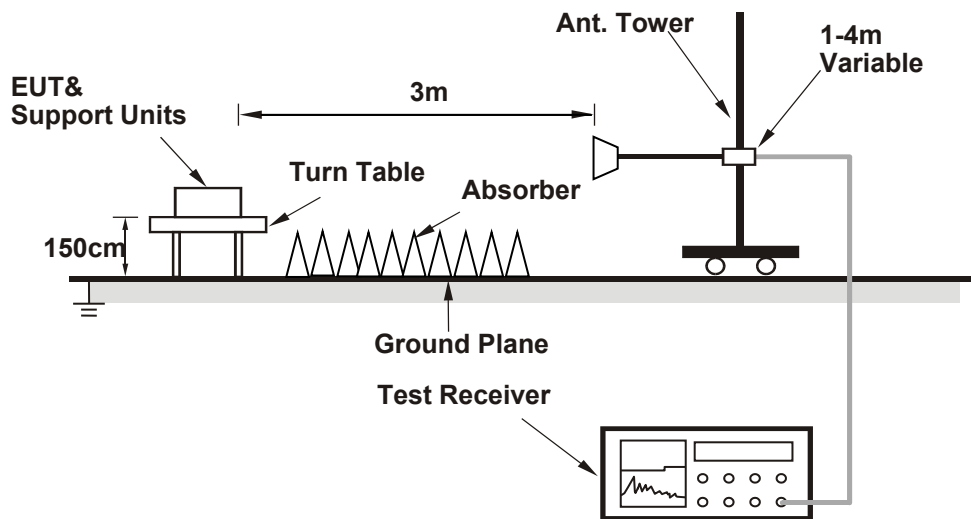

For the actual test configuration, please refer to the attached file (Test Setup Photo).

4.1.6 EUT Operating Conditions

- a. Placed the EUT on the testing table.
- b. Prepared a notebook to act as a communication partner and placed it outside of testing area.
- c. The communication partner connected with EUT via a RJ45 cable and ran a test program (provided by manufacturer) to enable EUT under transmission condition continuously at specific channel frequency.
- d. The communication partner sent data to EUT by command "PING".

4.1.7 Test Results

Above 1GHz Data:

802.11ax (HE20) + 802.11a

CHANNEL	CH 6 + CH 144	DETECTOR FUNCTION	Peak (PK) Average (AV)
FREQUENCY RANGE	1GHz ~ 40GHz		

ANTENNA POLARITY & TEST DISTANCE: HORIZONTAL AT 3 M								
NO.	FREQ. (MHz)	EMISSION LEVEL (dBuV/m)	LIMIT (dBuV/m)	MARGIN (dB)	ANTENNA HEIGHT (m)	TABLE ANGLE (Degree)	RAW VALUE (dBuV)	CORRECTION FACTOR (dB/m)
1	2390.00	58.8 PK	74.0	-15.2	1.23 H	24	25.9	32.9
2	2390.00	47.0 AV	54.0	-7.0	1.23 H	24	14.1	32.9
3	*2437.00	106.0 PK			1.23 H	24	73.1	32.9
4	*2437.00	94.0 AV			1.23 H	24	61.1	32.9
5	2483.50	59.0 PK	74.0	-15.0	1.23 H	24	26.1	32.9
6	2483.50	46.5 AV	54.0	-7.5	1.23 H	24	13.6	32.9
7	4874.00	46.3 PK	74.0	-27.7	1.99 H	42	43.9	2.4
8	4874.00	37.5 AV	54.0	-16.5	1.99 H	42	35.1	2.4
9	*5720.00	113.3 PK			2.11 H	125	71.9	41.4
10	*5720.00	102.9 AV			2.11 H	125	61.5	41.4
11	#5850.00	58.2 PK	68.2	-10.0	2.00 H	100	54.3	3.9
12	11440.00	55.5 PK	74.0	-18.5	1.80 H	170	46.5	9.0
13	11440.00	45.0 AV	54.0	-9.0	1.80 H	170	36.0	9.0

Remarks:

1. Emission Level(dBuV/m) = Raw Value(dBuV) + Correction Factor(dB/m).
2. Correction Factor(dB/m) = Antenna Factor(dB/m) + Cable Factor(dB) – Pre-Amplifier Factor(dB).
3. Margin value = Emission Level – Limit value.
4. The other emission levels were very low against the limit.
5. " * ": Fundamental frequency.
6. " # ": The radiated frequency is out of the restricted band.

802.11ax (HE20) + 802.11a

CHANNEL	CH 6 + CH 144	DETECTOR FUNCTION	Peak (PK) Average (AV)
FREQUENCY RANGE	1GHz ~ 40GHz		

ANTENNA POLARITY & TEST DISTANCE: VERTICAL AT 3 M								
NO.	FREQ. (MHz)	EMISSION LEVEL (dBuV/m)	LIMIT (dBuV/m)	MARGIN (dB)	ANTENNA HEIGHT (m)	TABLE ANGLE (Degree)	RAW VALUE (dBuV)	CORRECTION FACTOR (dB/m)
1	2390.00	67.5 PK	74.0	-6.5	1.60 V	0	34.6	32.9
2	2390.00	53.5 AV	54.0	-0.5	1.60 V	0	20.6	32.9
3	*2437.00	120.6 PK			1.60 V	0	87.7	32.9
4	*2437.00	108.0 AV			1.60 V	0	75.1	32.9
5	2483.50	64.7 PK	74.0	-9.3	1.60 V	0	31.8	32.9
6	2483.50	51.1 AV	54.0	-2.9	1.60 V	0	18.2	32.9
7	4874.00	46.3 PK	74.0	-27.7	1.48 V	16	43.9	2.4
8	4874.00	34.0 AV	54.0	-20.0	1.48 V	16	31.6	2.4
9	*5720.00	125.1 PK			2.00 V	352	83.7	41.4
10	*5720.00	113.9 AV			2.00 V	352	72.5	41.4
11	#5850.00	59.3 PK	68.2	-8.9	2.00 V	0	55.4	3.9
12	11440.00	56.5 PK	74.0	-17.5	1.00 V	189	47.5	9.0
13	11440.00	45.6 AV	54.0	-8.4	1.00 V	189	36.6	9.0

Remarks:

1. Emission Level(dBuV/m) = Raw Value(dBuV) + Correction Factor(dB/m).
2. Correction Factor(dB/m) = Antenna Factor(dB/m) + Cable Factor(dB) – Pre-Amplifier Factor(dB).
3. Margin value = Emission Level – Limit value.
4. The other emission levels were very low against the limit.
5. " * ": Fundamental frequency.
6. " # ": The radiated frequency is out of the restricted band.

Below 1GHz data

802.11ax (HE20) + 802.11a

CHANNEL	CH 6 + CH 144	DETECTOR FUNCTION	Quasi-Peak (QP)
FREQUENCY RANGE	9kHz ~ 1GHz		

ANTENNA POLARITY & TEST DISTANCE: HORIZONTAL AT 3 M								
NO.	FREQ. (MHz)	EMISSION LEVEL (dBuV/m)	LIMIT (dBuV/m)	MARGIN (dB)	ANTENNA HEIGHT (m)	TABLE ANGLE (Degree)	RAW VALUE (dBuV)	CORRECTION FACTOR (dB/m)
1	36.49	28.4 QP	40.0	-11.6	1.50 H	131	42.4	-14.0
2	122.15	34.5 QP	43.5	-9.0	1.50 H	128	49.6	-15.1
3	208.48	35.3 QP	43.5	-8.2	1.50 H	222	51.7	-16.4
4	293.84	35.0 QP	46.0	-11.0	1.01 H	184	47.6	-12.6
5	799.21	35.8 QP	46.0	-10.2	1.50 H	57	38.6	-2.8
6	992.24	30.9 QP	54.0	-23.1	1.50 H	2	31.1	-0.2

Remarks:

1. Emission Level(dBuV/m) = Raw Value(dBuV) + Correction Factor(dB/m).
2. Correction Factor(dB/m) = Antenna Factor(dB/m) + Cable Factor(dB) – Pre-Amplifier Factor(dB).
3. The other emission levels were very low against the limit of frequency range 30MHz ~ 1000MHz.
4. Margin value = Emission Level – Limit value.
5. The emission levels were very low against the limit of frequency range 9kHz ~ 30MHz: the amplitude of spurious emissions attenuated more than 20 dB below the permissible value to be report.

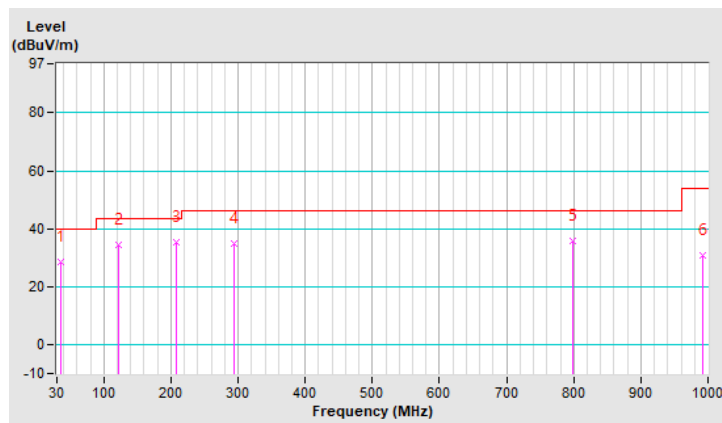

CHANNEL	CH 6 + CH 144	DETECTOR FUNCTION	Quasi-Peak (QP)
FREQUENCY RANGE	9kHz ~ 1GHz		

ANTENNA POLARITY & TEST DISTANCE: VERTICAL AT 3 M								
NO.	FREQ. (MHz)	EMISSION LEVEL (dBuV/m)	LIMIT (dBuV/m)	MARGIN (dB)	ANTENNA HEIGHT (m)	TABLE ANGLE (Degree)	RAW VALUE (dBuV)	CORRECTION FACTOR (dB/m)
1	35.52	38.7 QP	40.0	-1.3	1.00 V	196	54.9	-16.2
2	101.78	34.2 QP	43.5	-9.3	1.49 V	182	53.8	-19.6
3	177.44	36.8 QP	43.5	-6.7	1.00 V	34	53.6	-16.8
4	277.35	36.6 QP	46.0	-9.4	1.49 V	99	52.4	-15.8
5	785.69	38.8 QP	46.0	-7.2	1.99 V	2	45.0	-6.2
6	959.26	33.2 QP	46.0	-12.8	1.49 V	4	37.1	-3.9

Remarks:

1. Emission Level(dBuV/m) = Raw Value(dBuV) + Correction Factor(dB/m).
2. Correction Factor(dB/m) = Antenna Factor(dB/m) + Cable Factor(dB) – Pre-Amplifier Factor(dB).
3. The other emission levels were very low against the limit of frequency range 30MHz ~ 1000MHz.
4. Margin value = Emission Level – Limit value.
5. The emission levels were very low against the limit of frequency range 9kHz ~ 30MHz: the amplitude of spurious emissions attenuated more than 20 dB below the permissible value to be report.

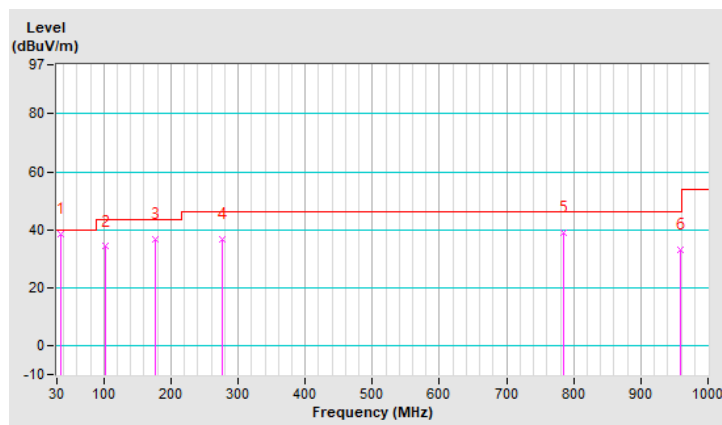

5 Pictures of Test Arrangements

Please refer to the attached file (Test Setup Photo).

Appendix – Information of the Testing Laboratories

We, Bureau Veritas Consumer Products Services (H.K.) Ltd., Taoyuan Branch, were founded in 1988 to provide our best service in EMC, Radio, Telecom and Safety consultation. Our laboratories are FCC recognized accredited test firms and accredited and approved according to ISO/IEC 17025.

If you have any comments, please feel free to contact us at the following:

Lin Kou EMC/RF Lab

Tel: 886-2-26052180

Fax: 886-2-26051924

Hsin Chu EMC/RF/Telecom Lab

Tel: 886-3-6668565

Fax: 886-3-6668323

Hwa Ya EMC/RF/Safety Lab

Tel: 886-3-3183232

Fax: 886-3-3270892

Email: service.adt@tw.bureauveritas.com

Web Site: www.bureauveritas-adt.com

The address and road map of all our labs can be found in our web site also.

--- END ---