



WatchGuard AP332CR

Hardware Guide

WatchGuard AP332CR
Outdoor Access Point

About This Guide

Information in this guide is subject to change without notice. Companies, names, and data used in examples herein are fictitious unless otherwise noted. No part of this guide may be reproduced or transmitted in any form or by any means, electronic or mechanical, for any purpose, without the express written permission of WatchGuard Technologies, Inc.

Guide revised: 7/11/2022

Copyright, Trademark, and Patent Information

Copyright © 1998 - 2022 WatchGuard Technologies, Inc. All rights reserved. All trademarks or trade names mentioned herein, if any, are the property of their respective owners.

Complete copyright, trademark, patent, and licensing information can be found in the Copyright and Licensing Guide, available online at <https://www.watchguard.com/wgrd-help/documentation/overview>.

About WatchGuard

WatchGuard® Technologies, Inc. is a global leader in network security, providing best-in-class Unified Threat Management, Next Generation Firewall, secure Wi-Fi, and network intelligence products and services to more than 75,000 customers worldwide. The company's mission is to make enterprise-grade security accessible to companies of all types and sizes through simplicity, making WatchGuard an ideal solution for Distributed Enterprises and SMBs. WatchGuard is headquartered in Seattle, Washington, with offices throughout North America, Europe, Asia Pacific, and Latin America. To learn more, visit WatchGuard.com.

For additional information, promotions and updates, follow WatchGuard on Twitter, @WatchGuard on Facebook, or on the LinkedIn Company page. Also, visit our InfoSec blog, Secplicity, for real-time information about the latest threats and how to cope with them at www.secplicity.org.

Address

505 Fifth Avenue South
Suite 500
Seattle, WA 98104

Support

www.watchguard.com/support
U.S. and Canada +877.232.3531
All Other Countries +1.206.521.3575

Sales

U.S. and Canada +1.800.734.9905
All Other Countries +1.206.613.0895

Contents

WatchGuard AP332CR Hardware Guide	6
Access Point Management	7
About Your Hardware	7
Hardware Specifications	7
Environmental Requirements	8
Hardware Description	9
Bottom Panel	9
Top Panel	9
Rear Panel	10
Side Panel	10
Mount and Connect the Access Point	15
Wall Mount Installation	16
Pole Mount Installation	17
Antenna Installation	18
Connect the Ground Wire	18
Connect the Access Point	19
How to Assemble the Weatherproof Connector	20
How to Disassemble the Weatherproof Connector	21
Ethernet Power Injector (Optional)	22
Notices	24
Safety Warning	24
FCC Certification	24
CE Notice	25
Industry Canada Certification	25
EU Declaration of Conformity	27
Brazil ANATEL	29

CISPR 22 Statement	29
Mexico NOM.....	29
Japan Statement.....	29
Japan VCCI Class B Statement	29
Taiwan NCC Statement.....	29
RoHS Statement.....	30
WEEE Statement.....	30
REACH Certificate of Compliance.....	30
Declaration of Conformity.....	32

WatchGuard AP332CR Hardware Guide

The WatchGuard AP332CR is designed for indoor or rugged outdoor deployment conditions and built with an industrial-rated IP67 enclosure.

The AP332CR features 802.11ax 2x2 2.4 GHz and 5 GHz dual concurrent radios that support data rates up to 1148 Mbps on the 2.4 GHz band and 2402 Mbps on the 5 GHz band.

Power is provided by a PoE+ (Power over Ethernet) power source.



Access Point Management

You can manage the AP332CR with WatchGuard Cloud. WatchGuard Cloud delivers a simplified platform for Wi-Fi management to easily deploy, configure, and monitor your wireless networks.

For more information on how to set up your access point with WatchGuard Cloud, see watchguard.com/start.

About Your Hardware

Hardware Specifications

Hardware	Description
Processor	Qualcomm Cypress IPQ6010-0 Cypress Quad-core A53 1.8GHz
Memory	<ul style="list-style-type: none"> ■ NOR Flash 8MB ■ NAND Flash 256MB ■ RAM: DDR3L 512MB x 2
Radios	<ul style="list-style-type: none"> ■ Radio 1: 2.4 GHz 2x2 802.11b/g/n/ax ■ Radio 2: 5 GHz 2x2 802.11a/n/ac/ax
Antennas	<ul style="list-style-type: none"> ■ 2 x 2.4 GHz, 5 dBi ■ 2 x 5 GHz, 5 dBi <p>4 x omnidirectional antennas are included.</p> <p>Note: The device must have antennas connected for full range and functionality.</p>
Ethernet Interfaces	1 x 2.5 GbE Ethernet port
Power Interface	PoE+ 802.3at 48-57V DC
Power Consumption	<ul style="list-style-type: none"> ■ Average: 11.52W ■ Peak: 11.98W
MTBF (Mean Time Between Failures)	25,000 hours at 25°C / 77°F
Dimensions	190mm x 124mm x 47mm (7.5" x 4.9" x 1.85")
Weight	0.82 kg (1.8 lbs)

Environmental Requirements

To safely install your WatchGuard access point, we recommend that you:

- Install the device per local regulations
- Make sure the device has adequate clearance for air flow and cooling

This equipment is not suitable for use in locations where children are likely to be present.

Other environmental requirements:

Operating Temperature	-20°C to 60°C (-4°F to 140°F)
Operating Humidity	5% to 95% non-condensing
Non-operating Temperature	-40°C to 80°C (-40°F to 176°F)
Non-operating Humidity	5% to 95%, non-condensing

Hardware Description



Bottom Panel

2.4GHz

Antenna connector for the 2.4 GHz radio.

LAN (PoE)

The LAN (PoE) port is a 2.5 GbE port that connects the access point to a wired LAN connection through a switch or hub. This port also provides PoE+ (802.3at) power for the access point.

5GHz

Antenna connector for the 5 GHz radio.

Top Panel



5GHz

Antenna connector for the 5 GHz radio.

2.4GHz

Antenna connector for the 2.4 GHz radio.

Rear Panel

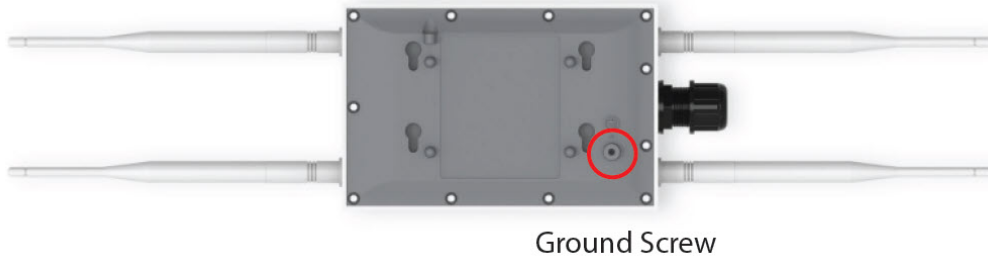

Ground Connector

Use the included ground screw to attach the ground wire to the ground connector on the rear of the access point and attach the other end of the wire to a nearby grounding point.

Side Panel

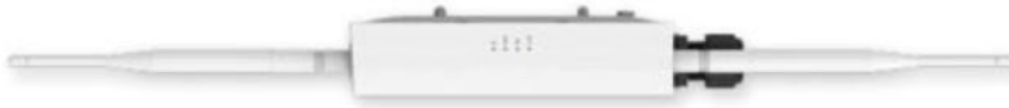

LED Indicators

The access point has LED indicators that can show status conditions for the device connection to WatchGuard Cloud. The LED indicator status depends on the firmware version on the device.

Access Point Firmware 1.1.7-0 and Higher

Wi-Fi in WatchGuard Cloud access points that run firmware 1.1.7-0 and higher have LED indicators that can show different status conditions while booting, activation validation, feature key download, WatchGuard Cloud device registration, and the connection to WatchGuard Cloud.

The access point briefly passes through each stage until the device is connected to WatchGuard Cloud and shows a solid blue LED indicator. If the access point remains in the same state for a long period of time without a solid blue LED indicator status, there might be a network issue, activation or feature key issue, or a problem with your WatchGuard Cloud account.

Check the following table for the status of the LED indicators and how to troubleshoot the issue.

LED Color	Status	Troubleshooting
Solid Red or Orange	Device is booting	<p>If the access point remains in this state, the access point processes might not have started, or there might be an issue with the access point firmware.</p> <ul style="list-style-type: none"> ■ Disconnect and reconnect power to reboot the access point to see whether the device connects. ■ Try to log in to the access point command line interface (CLI) to check the device status, current firmware version, and run diagnostic tests. For more information, see Access Point Command Line Interface.
Flashing Red or Orange (Fast: 100 milliseconds)	Validate access point activation and download feature key	<p>If the access point remains in this state:</p> <ul style="list-style-type: none"> ■ Make sure you have activated your access point with a valid device serial number and license key in your WatchGuard account. The license key must be for a WatchGuard Standard or USP Wi-Fi license for Wi-Fi in WatchGuard Cloud. ■ Make sure the access point is connected to the network and has received an IP address from DHCP. ■ Make sure the access point can connect to *.<i>watchguard.io</i> for product activation and feature key updates. ■ If you set up an access point behind a firewall that performs inspection on HTTPS traffic, you must add *.<i>watchguard.io</i> to the content inspection exception / bypass list to enable the access point to receive a feature key from WatchGuard servers. On the WatchGuard Firebox, this is enabled by default for cloud-managed Fireboxes in WatchGuard Cloud. ■ Use the access point command line interface (CLI) to check the feature key status, download a feature key, and run diagnostic tests. For more information, see Access Point Command Line Interface.
Flashing Red or Orange (Medium: 500 milliseconds)	WatchGuard Cloud device registration	<p>If the access point remains in this state:</p> <ul style="list-style-type: none"> ■ Make sure access point can connect to *.<i>watchguard.com</i> for WatchGuard Cloud device registration.

LED Color	Status	Troubleshooting
		<ul style="list-style-type: none"> ■ For service providers, make sure you have allocated the access point from your inventory to a subscriber account. For more information, see Access Point Allocation. ■ Make sure you have added the access point to your WatchGuard Cloud subscriber account. For more information, see Add an Access Point to WatchGuard Cloud.
Flashing Red or Orange (Slow: 2 seconds)	Connection to WatchGuard Cloud servers	<p>If the access point remains in this state:</p> <ul style="list-style-type: none"> ■ Make sure the access point can connect to *.<i>watchguard.com</i> for WatchGuard Cloud management connections and is not blocked by a firewall or other network device. ■ Make sure you do not have an expired MSSP license for the access point. ■ Check the access point allocation status to see whether the device was deallocated from the subscriber account.
Solid Blue	Successfully connected to WatchGuard Cloud	Device is online and connected to WatchGuard Cloud.
Flashing Blue	Flash LED action from WatchGuard Cloud	LED flashes blue for 60 seconds for identification.

Access Point Firmware 1.1.4-0 and Lower

Wi-Fi in WatchGuard Cloud access points that run firmware 1.1.4-0 and lower have basic LED indicators that can show if the device is successfully connected to WatchGuard Cloud.

If the access point remains in the same state for a long period of time without a solid blue LED indicator status, there might be a network issue, activation or feature key issue, or a problem with your WatchGuard Cloud account.

Check the following table for the status of the LED indicators and how to troubleshoot the issue.

LED Color	Status	Troubleshooting
Solid Red or Orange	Device is booting and connecting to WatchGuard Cloud	<p>A permanent solid red or orange LED after booting is very rarely a hardware issue. It might take several minutes before the access point successfully connects to WatchGuard Cloud. In most cases a network issue, blocked port, licensing, or WatchGuard Cloud account issue will result in the access point not connecting or appearing in your WatchGuard Cloud account.</p> <ul style="list-style-type: none">■ Make sure you have activated your access point with a valid device serial number and license key in your WatchGuard account.■ If you are a service provider, make sure you have allocated the activated access point to a subscriber account in WatchGuard Cloud. For more information, see Access Point Allocation.■ Make sure you have added the access point device to your WatchGuard Cloud subscriber account. For more information, see Add an Access Point to WatchGuard Cloud.■ If you have configured DHCP, make sure your access point has received an IP address from DHCP and can connect to the network.■ Access points use TCP port 443 to connect to WatchGuard Cloud. Access points must also be able to connect to these destinations:<ul style="list-style-type: none">○ *.<i>watchguard.io</i> for product activation and feature key updates○ *.<i>watchguard.com</i> for WatchGuard Cloud registration and connections■ If you set up an access point behind a firewall that performs inspection on HTTPS traffic, you must add *.<i>watchguard.io</i> to the content inspection exception / bypass list to enable the access point to receive a feature key from WatchGuard servers. On the WatchGuard Firebox, this is enabled by default for cloud-managed Fireboxes in WatchGuard Cloud. <p>Use the access point command line interface (CLI) to check the feature key status, download a feature key, and run diagnostic tests. For more information, see Access Point Command Line Interface.</p>

LED Color	Status	Troubleshooting
Flashing Red or Orange	Device cannot connect to WatchGuard Cloud	<p>This can occur for several reasons, for example:</p> <ul style="list-style-type: none"> ■ Device did not receive an IP address from DHCP ■ Device cannot connect to *.<i>watchguard.com</i> or *.<i>watchguard.io</i> because of a network issue or blocked port <p>Use the access point command line interface (CLI) to run network connectivity diagnostic tests. For more information, see Access Point Command Line Interface.</p>
Solid Blue	Successfully connected to WatchGuard Cloud	Device is online and connected to WatchGuard Cloud.
Flashing Blue	Flash LED action from WatchGuard Cloud	LED flashes blue for 60 seconds for identification.



Current factory default access points ship with firmware version 1.1.4-0 or lower.

Mount and Connect the Access Point

Your package includes these accessories:

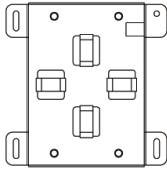

Mounting
Bracket



Mounting
Screws



Pole Mount
Straps x 2

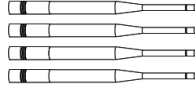

Antennas x 4
(2 x 2.4GHz, 2 x 5GHz)



Ground Cable
and Screw



The MAC address and serial number of your access point are printed on a label on the back of the device. Make sure you record this information before you mount the device.

Wall Mount Installation

Use the supplied wall-mounting accessories to install the access point on a wall.

1. Mark the location on the wall surface for the four mounting holes of the wall mounting bracket.
 - Use an appropriate drill bit to drill holes that are 8.1mm diameter and 26mm depth in the markings and hammer the bolts into the openings.
 - Screw the anchors into the holes until they are flush with the wall.
2. Screw the included screws into the anchors.
3. Slide the mount bracket into the slot of the access point.

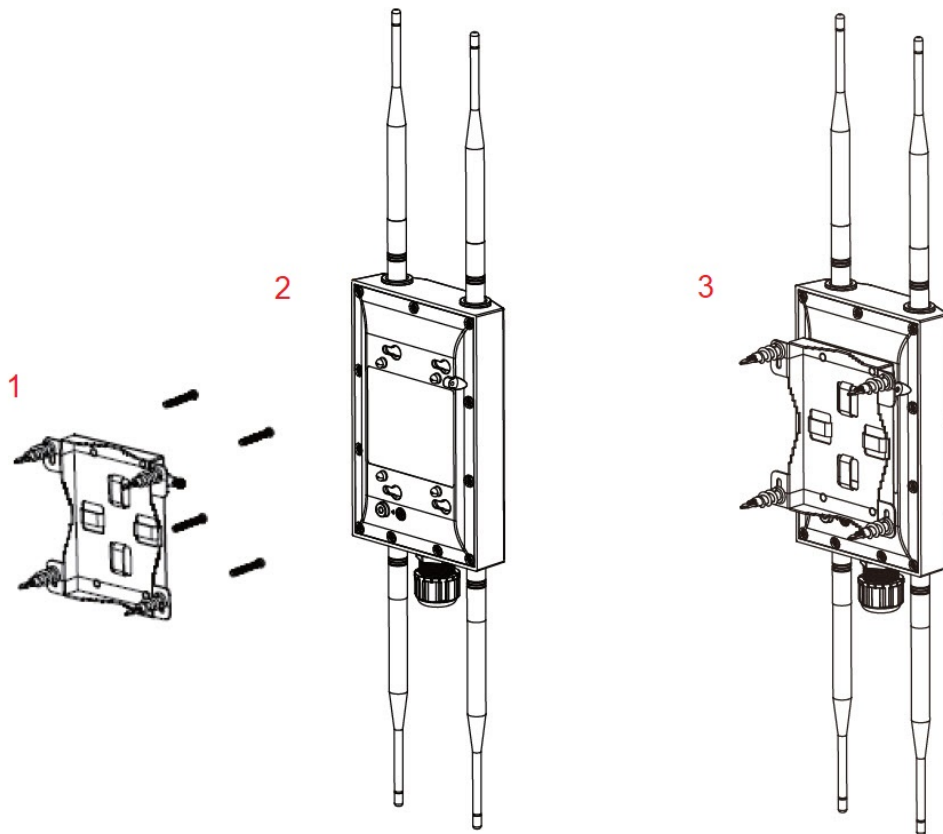

Pole Mount Installation

Use the supplied pole mount accessories to install the access point on a pole.

1. Insert the pole mount clamps in the tabs on the mounting bracket and wrap the clamps around the pole.
2. Attach the access point to the mounting bracket and tighten the straps to make sure the access point is firmly attached to the pole.

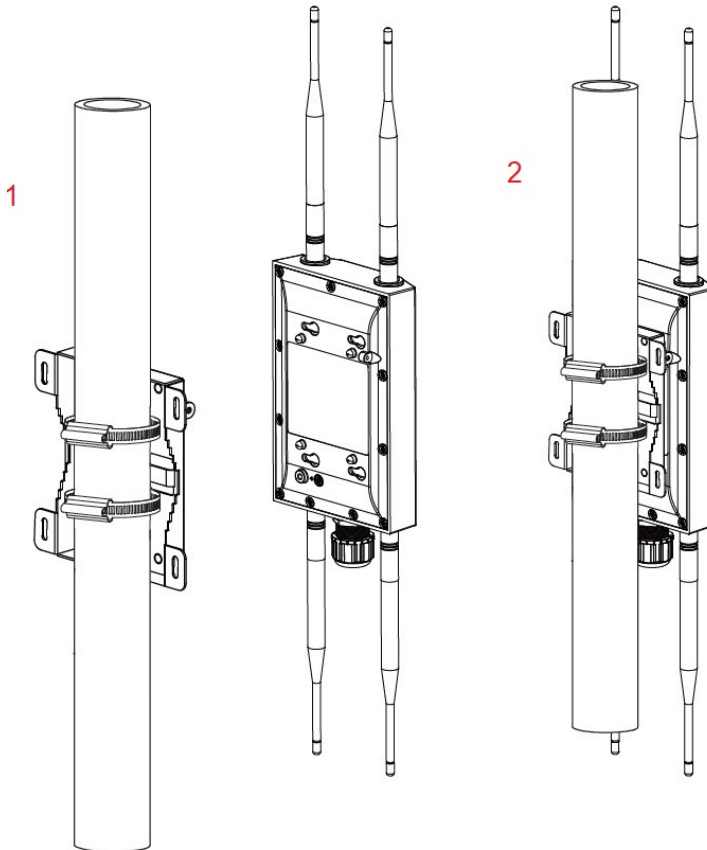

Antenna Installation

The access point includes four antennas.

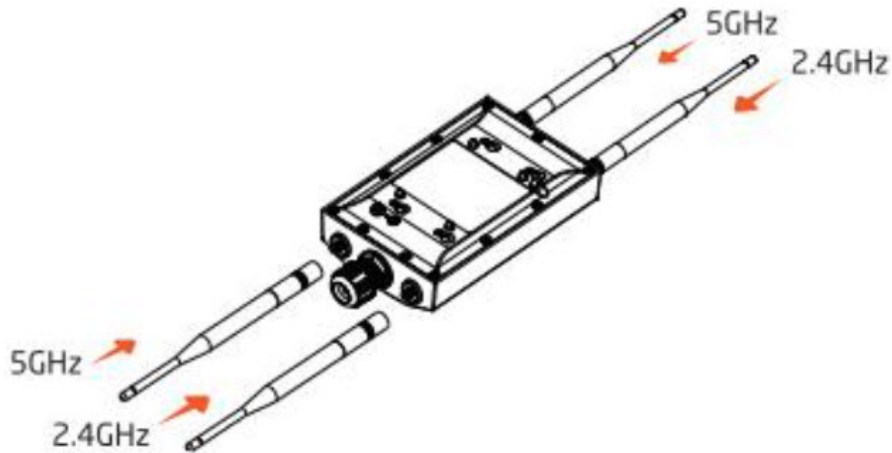

- The access point requires two antennas for each radio.
- On the top and bottom of the access point, there are two connectors for the 2.4 and 5 GHz radios
- Insert the antennas into the connectors for each radio and turn clockwise to tighten.



The device must have antennas connected for full range and functionality.

You can use other third-party omnidirectional and directional antennas based on your deployment requirements. If you use other third-party antenna types, you are responsible for verifying compliance with regional-based regulations based on the peak gain values.

Connect the Ground Wire

To make sure your access point is safely protected from electrical events, we recommend you ground the access point according to your local regulations.

Use the included screw to attach the ground wire to the ground connector on the access point and attach the other end of the wire to a nearby grounding point.

Connect the Access Point

Plug one end of the Ethernet cable from your network into the LAN (PoE) port on the bottom panel of the access point.

Make sure the other end of the Ethernet cable is connected to your network through a hub, switch, or injector with PoE+ (802.3at) power enabled.

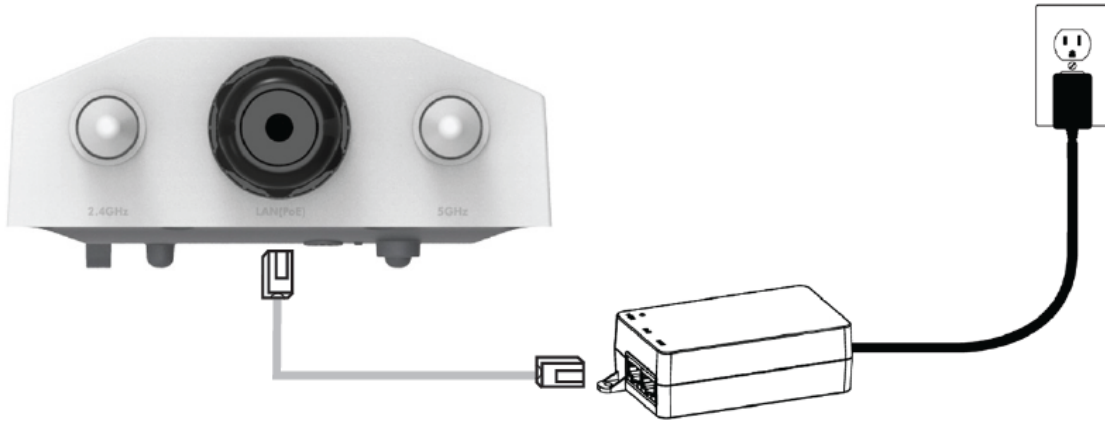

Access Point connected to PoE+ injector



Access Point connected to switch with PoE+ power

How to Assemble the Weatherproof Connector

Use these instructions to connect the Ethernet cable to the access point through the weatherproof connector.

1

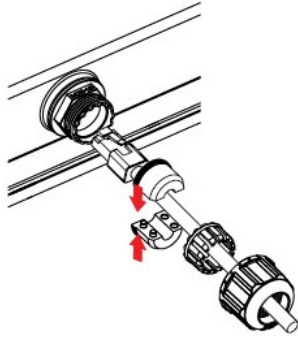

2

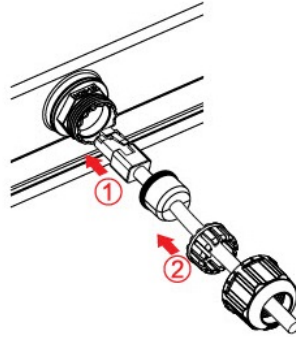

3

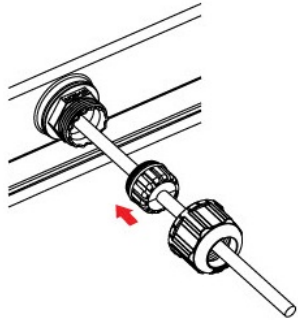

4

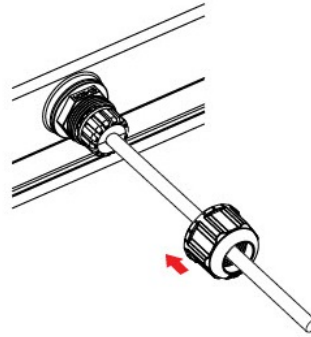

5

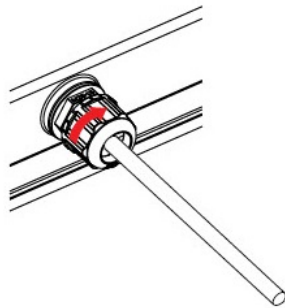

How to Disassemble the Weatherproof Connector

Use these instructions to disconnect the Ethernet cable from the weatherproof connector.

1

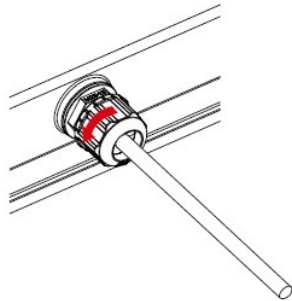

2

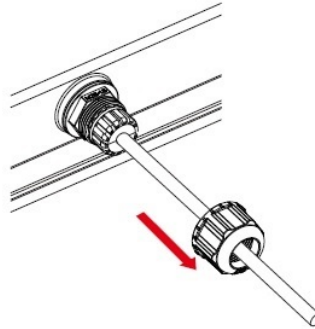

3

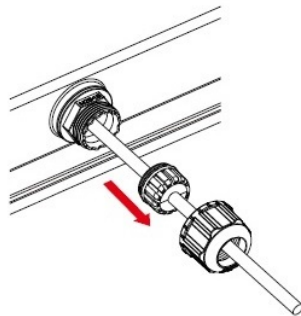

4

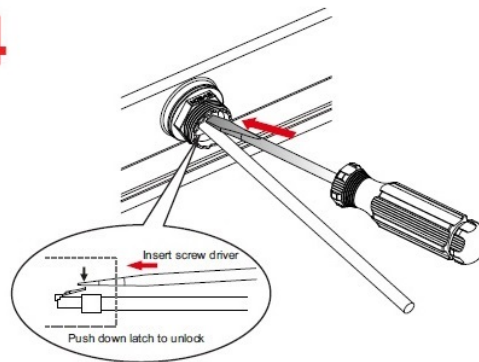

5

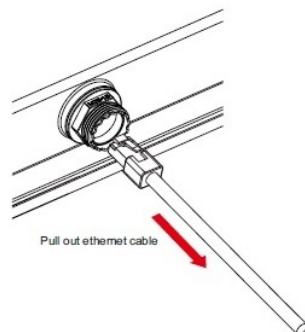

Ethernet Power Injector (Optional)

You can power the access point with an optional Ethernet Power Injector. The PoE+ power injector enables you to power the access point through an existing Ethernet connection. With this device, you do not have to position your access point near a power outlet.



This device complies with IEEE 802.3at/af PoE specifications. Do not use any PoE adapters that are not IEEE 802.3at/af compliant as they may damage your device.

To connect an Ethernet Power Injector to the WatchGuard access point:

1. Plug the Ethernet Power Injector into an AC power source.
2. Connect an Ethernet cable from your network backbone (for example, a PoE-capable router, switch, or hub) to the **LAN** connector on the Ethernet Power Injector.
3. Connect an Ethernet cable from the **LAN (PoE)** Ethernet interface on the access point to the **PoE** connector on the Ethernet Power Injector.

The table provides the specifications for the power adapter.

Ethernet Power Injector Specs	
WatchGuard Part Number	802.3at PoE+ Injector with AC cord (US/FCC) (WG8599) 802.3at PoE+ Injector with AC cord (CE) (WG8600) 802.3at PoE+ Injector with AC cord (UK) (WG8601) 802.3at PoE+ Injector with AC cord (AUS) (WG8602)
Specification	IEEE 802.3at/af
AC Input Voltage Rating	100-240VAC
Input Current	0.8A max for 100VAC

Ethernet Power Injector Specs	
Output Power	30W maximum
Ethernet Interfaces	LAN: RJ-45 for 10/100/1000/2500 Mbps data POE: RJ-45 for 10/100/1000/2500 Mbps data and power Voltage: Pin4, 5:54V, Pin7, 8:Return
Indicator	Power: Green
Temperature	Operating: 0 - 40°C (32 - 104°F) Storage: -30 - 80°C (-22 - 176°F)
Humidity	5% - 90% (Operating and storage)
Dimensions	L = 99 mm (3.9") W = 68.5 mm (2.27") H = 33 mm (1.3")
Weight	149.6 g (0.33 lbs)

Notices

All WatchGuard products are designed and tested to meet strict safety requirements. These requirements include product safety approvals and other global compliance standards. Please read these instructions carefully before operating the product, and refer to them as needed to ensure the continued safe operation of your product.

For patent information, please visit <http://www.watchguard.com/patents>

Safety Warning

If protective earthing is used as a safeguard, the instructions shall require connection of the equipment protective earthing conductor to the installation protective earthing conductor (for example, by means of a power cord connected to a socket-outlet with earthing connection). To meet safety and electromagnetic interference (EMI) requirements, you must make sure the power source is connected to earth ground before you connect power to the access point.

FCC Certification

This device complies with part 15 of the FCC Rules. Operation is subject to the following two conditions: (1) This device may not cause harmful interference, and (2) this device must accept any interference received, including interference that may cause undesired operation.

This equipment has been tested and found to comply with the limits for a Class B digital device, pursuant to part 15 of the FCC Rules. These limits are designed to provide reasonable protection against harmful interference in a residential installation.

This equipment generates, uses and can radiate radio frequency energy and, if not installed and used in accordance with the instructions, may cause harmful interference to radio communications. However, there is no guarantee that interference will not occur in a particular installation. If this equipment does cause harmful interference to radio or television reception, which can be determined by turning the equipment off and on, the user is encouraged to try to correct the interference by one or more of the following measures:

- Reorient or relocate the receiving antenna.
- Increase the separation between the equipment and receiver.
- Connect the equipment into an outlet on a circuit different from that to which the receiver is connected.
- Consult the dealer or an experienced radio/TV technician for help.

FCC Caution: Any changes or modifications not expressly approved by the party responsible for compliance could void the user's authority to operate this equipment.

This transmitter must not be co-located or operating in conjunction with any other antenna or transmitter.

This device meets all the other requirements specified in Part 15E, Section 15.407 of the FCC Rules.

Radiation Exposure Statement:

This equipment complies with FCC radiation exposure limits set forth for an uncontrolled environment. This equipment should be installed and operated with minimum distance 40cm between the radiator & your body.

CE Notice

The CE symbol on your WatchGuard Technologies equipment indicates that it is in compliance with the Electromagnetic Compatibility (EMC) directive and the Low Voltage Directive (LVD) of the European Union (EU).



Industry Canada Certification

This device complies with ISED's licence-exempt RSSs. Operation is subject to the following two conditions: (1) This device may not cause harmful interference, and (2) this device must accept any interference received, including interference that may cause undesired operation.

Le présent appareil est conforme aux CNR d'ISED applicables aux appareils radio exempts de licence. L'exploitation est autorisée aux deux conditions suivantes: (1) le dispositif ne doit pas produire de brouillage préjudiciable, et (2) ce dispositif doit accepter tout brouillage reçu, y compris un brouillage susceptible de provoquer un fonctionnement indésirable.

Caution

For devices with detachable antenna(s), the maximum antenna gain permitted for devices in the bands 5250-5350 MHz and 5470-5725 MHz must be such that the equipment still complies with the e.i.r.p. limit.

For devices with detachable antenna(s), the maximum antenna gain permitted for devices in the band 5725-5850 MHz must be such that the equipment still complies with the e.i.r.p. limits as appropriate.

For systems that are capable of operating outdoors or with antennas mounted outdoors (where applicable antenna type(s), antenna models(s), and worst-case tilt angle(s)) are necessary to remain compliant with the e.i.r.p, therefore, the elevation mask requirement set forth in section 6.2.2.3 should be clearly indicated.

Avertissement

Pour les appareils avec antenne(s) amovible(s), le gain d'antenne maximal autorisé pour les appareils dans les bandes 5250-5350 MHz et 5470-5725 MHz doit être tel que l'équipement soit toujours conforme à la e.i.r.p. limite.

Pour les appareils avec antenne(s) amovible(s), le gain d'antenne maximal autorisé pour les appareils dans la bande 5725-5850 MHz doit être tel que l'équipement soit toujours conforme à la p.i.r.e. limites le cas échéant.

Lorsqu'il y a lieu, les types d'antennes (s'il y en a plusieurs), les numéros de modèle de l'antenne et les pires angles d'inclinaison nécessaires pour rester conforme à l'exigence de la p.i.r.e. applicable au masque d'élévation, énoncée à la section 6.2.2.3, doivent être clairement indiqués

Radiation Exposure Statement

This equipment complies with ISED radiation exposure limits set forth for an uncontrolled environment. This equipment should be installed and operated with minimum distance 42cm between the radiator & your body.

Déclaration d'exposition aux radiations

Cet équipement est conforme aux limites d'exposition aux rayonnements ISED établies pour un environnement non contrôlé. Cet équipement doit être installé et utilisé avec un minimum de 42cm de distance entre la source de rayonnement et votre corps.

EU Declaration of Conformity

This device complies with the essential requirements of the RED Directive 2014/53/EU. The following test methods have been applied in order to prove presumption of conformity with the essential requirements of the RED Directive 2014/53/EU:

EN 62368-1:2014+A11:2017

Safety of Information Technology Equipment (ITE)

EN 55024:2010+A1:2015

Immunity for Information Technology Equipment (ITE)

EN 55032:2015+A11:2020

Electromagnetic compatibility of multimedia equipment - Emission requirements.

EN 55035: 2017/A11:2020

Electromagnetic compatibility of multimedia equipment – Immunity Requirements

EN 61000-3-2:2014

Limits for harmonic current emissions.

EN 61000-3-3:2013

Limitation of voltage changes, voltage fluctuations and flicker in public low-voltage supply systems, for equipment with rated current ≤ 16 A per phase and not subject to conditional connection.

EN 62311:2008

Assessment of electronic and electrical equipment related to human exposure restrictions for electromagnetic fields (0 Hz - 300 GHz).

EN 301 489-1 V2.2.3

Electromagnetic compatibility and Radio spectrum Matters (ERM); Electro Magnetic Compatibility (EMC) standard for radio equipment and services; Part 1: Common technical requirements

EN 301 489-17 V3.1.1

Electromagnetic compatibility and Radio spectrum Matters (ERM); ElectroMagnetic Compatibility (EMC) standard for radio equipment; Part 17: Specific conditions for Broadband Data Transmission Systems

This device is a 5 GHz wideband transmission system (transceiver), intended for use in all EU member states and EFTA countries, except in France and Italy where restrictive use applies. In Italy the end-user should apply for a license at the national spectrum authorities in order to obtain authorization to use the device for setting up outdoor radio links and/or for supplying public access to telecommunications and/or network services.

This device may not be used for setting up outdoor radio links in France and in some areas the RF output power may be limited to 10 mW EIRP in the frequency range of 2454 - 2483.5 MHz. For detailed information the end-user should contact the national spectrum authority in France.

EN 300 328 V2.2.2

Electromagnetic compatibility and Radio spectrum Matters (ERM); Wideband transmission systems; Data transmission equipment operating in the 2.4 GHz ISM band and using wide band modulation techniques; Harmonized EN covering the essential requirements of article 3.2 of the RED Directive

EN 301 893 V2.1.1

Broadband Radio Access Networks (BRAN); 5 GHz high performance RLAN; Harmonized EN covering the essential requirements of article 3.2 of the RED Directive

EN 50385: 2017

This product standard is related to human exposure to radio frequency electromagnetic fields transmitted by base station equipment in the frequency range 110 MHz to 100 GHz.

Brazil ANATEL

Este equipamento não tem direito à proteção contra interferência prejudicial e não pode causar interferência em sistemas devidamente autorizados.

CISPR 22 Statement

Este produto não é apropriado para uso em ambientes domésticos, pois poderá causar interferências eletromagnéticas que obrigam o usuário a tomar medidas necessárias para minimizar estas interferências.

This is a class A product. In a domestic environment, this product may cause radio interference in which case the user may be required to take adequate measures.

Mexico NOM

La operación de este equipo está sujeta a las siguientes dos condiciones:

- (1) es posible que este equipo o dispositivo no cause interferencia perjudicial y
- (2) este equipo o dispositivo debe aceptar cualquier interferencia, incluyendo la que pueda causar su operación no deseada.

Japan Statement

この装置には、電波法に基づく技術規則適合証明書の認定を受けた特定の無線装置が含まれています。

This equipment contains specified radio equipment that has been certified to the Technical Regulation Conformity Certification under Radio Law.

Japan VCCI Class B Statement

この装置は、クラスB情報技術装置です。この装置は、住宅環境で使用することを目的としていますが、この装置がラジオやテレビジョン受信機に近接して使用されると、受信障害を引き起こすことがあります。取扱説明書に従って正しい取り扱いをして下さい。VCCI-B

Taiwan NCC Statement

取得審驗證明之低功率射頻器材，非經核准，公司、商號或使用者均不得擅自變更頻率、加大功率或變更原設計之特性及功能。

低功率射頻器材之使用不得影響飛航安全及干擾合法通信；經發現有干擾現象時，應立即停用，並改善至無干擾時方得繼續使用。前述合法通信，指依電信管理法規定作業之無線電通信。低功率射頻器材須忍受合法通信或工業、科學及醫療用電波輻射性電機設備之干擾。

1. 使用此產品時應避免影響附近雷達系統之操作。

「本產品電磁波曝露量(MPE)標準值 $1\text{mW}/\text{cm}^2$ ，送測產品實測值為 $0.571\text{mW}/\text{cm}^2$ ，建議使用時至少距離人體 23cm 」

[警語內容]

本器材須經專業工程人員安裝及設定，始得設置使用，且不得直接販售給一般消費者。

RoHS Statement

The member states of the European Union approved directive 2002/95/EC, Restrictions of Hazardous Substances (“RoHS directive”) that became valid on July 1, 2006. It states that all new electrical and electronic equipment put on the market within the member states must not contain certain hazardous materials. This device complies with the European Union’s ROHS directive 2002/95/EC and similar regulations that may be adopted by other countries for European Sales.

WEEE Statement

WEEE is a general set of requirements dictated in the EU Directive 2002/96/EC. This Directive mandated that member EU countries enact regulations governing the Waste of Electrical and Electronic Equipment (WEEE). The Directive, and its individual transpositions into specific country laws and legislation, is aimed at the reduction of WEEE through reuse, recovery, and recycling of WEEE.

WatchGuard is working in partnership with our European Union (EU) distribution partners to ensure that our products are in compliance with the WEEE statutes, and that the recovery of our product per the specific EU country legislative requirements is seamless for our product’s end users. If you have a WatchGuard product that is at its end of life and needs to be disposed of, please contact WatchGuard Customer Care Department at:

U.S. Customers: 877.232.3531

International Customers: +1.206.613.0456

WatchGuard is reasonably confident that our products do not contain any substances or hazardous materials presently banned by any legislation, and do not present a risk due to hazardous materials. WEEE recovery professionals should also note that these products do not have any materials that are of particular high value in their individual form.

REACH Certificate of Compliance

The new EU chemicals policy REACH (Registration, Evaluation, Authorization and restriction of Chemicals) came into effect on June 1, 2007. REACH is Europe’s new chemicals legislation, which is applicable in all 27 EU Member States as well as the EFTA European Economic Area (EEA). REACH creates a new system for gathering information, assessing risks to human health and the environment, and authorizing or restricting the marketing and use of chemicals produced or supplied in the EEA. REACH has an impact on EEA producers and importers of finished products and users of chemicals in the course of industrial or professional activities.

WatchGuard supports the overall REACH objective of improving the protection of human health and the environment and will meet all applicable REACH requirements. WatchGuard is strongly committed to working with our customers and supply chain to define and implement the REACH requirements and ensure a smooth transition to compliance.

One of the REACH requirements is that manufacturers and importers have the duty to register substances they are producing or importing. In accordance with the regulations, the products of WatchGuard do not need to be registered for the following reasons:

- WatchGuard does not import more than 1 metric ton per year of a substance as defined by REACH.
- WatchGuard products are non-chemical products that are not designed to release any substance under normal and reasonably predictable application.
- Our products do not contain the listed substances at more than 0.1% by weight of the whole product/part.

Declaration of Conformity

Declaration of Conformity

WatchGuard Technologies Inc. hereby declares that the product(s) listed below conform to the European Union directives and standards identified in this declaration.

Product(s):

802.11 a/b/g/n/ac/ax Access Point, AP332CR

EU Directive(s):

Low Voltage (2014/35/EU)
 Electromagnetic Compatibility (2014/30/EU)
 Energy-related Products (2009/125/EC)
 RoHS (2011/65/EU and 2015/863/EU RoHS)
 WEEE Directive 2012/19/EU
 The Radio Equipment Directive (2014/53/EU)

Common Standard(s):

EN 62368-1:2014+A11:2017	Safety for ITE
EN 55032:2015+A11:2020	
EN 55035:2017/A11:2020	
EN 61000-3-2:2019	Harmonics
EN 61000-3-3:2013+A1:2019	Flicker

Wireless Standard(s):

EN 62311:2008	
EN 301 489-1 v2.2.3 (2019-11)	EMC and Radio Spectrum Matters
EN 301 489-17 v3.2.4 (2020-09)	EMC and Radio Spectrum Matters
EN 300 328 v2.2.2 (2019-07)	Radio Spectrum Matters
EN 301 893 v2.1.1 (2017-05)	Broadband Radio Access Networks

This device complies with Directive 2014/53/EU issued by the Commission of the European Community.

Manufacturer / Hersteller: WatchGuard Technologies
 505 5th Ave South, Suite 500, Seattle, WA 98104 USA

Radio Equipment / Funkanlage:	802.11 a/b/g/n/ac/ax Access Point
Type Designation / Typenbezeichnung:	AP332CR
Specifications / Technische Daten:	802.11a,b,g,n,ac,ax (2.4Ghz & 5GHz)
Intended Purpose / Verwendungszweck:	Outdoor access point
Equipment Class / Betriebsmittel der Klasse:	Class II
Operating temperature	-20° C to 60° C

The above device complies with the essential requirements and other relevant provisions to Directive 2014/53/EU when used for its intended purpose. This equipment may be operated in the USA, Canada, & Europe Union.

Warning! This is a Class B product. In a domestic environment this product may cause radio interference in which case the user may be required to take adequate measures.

Restrictions: France (i) les dispositifs fonctionnant dans la bande 5150-5250 MHz sont réservés uniquement pour une utilisation à l'intérieur afin de réduire les risques de brouillage préjudiciable aux systèmes de satellites mobiles utilisant les mêmes canaux; (ii) De plus, les utilisateurs devraient aussi être avisés que les utilisateurs de radars de haute puissance sont désignés utilisateurs principaux (c.-à-d., qu'ils ont la priorité) pour les bandes 5 250-5 350 MHz et 5 650-5 850 MHz et que ces radars pourraient causer du brouillage et/ou des dommages aux dispositifs LAN-EL. Die oben genannten Gerät entspricht den grundlegenden Anforderungen und anderen relevanten Bestimmungen der Richtlinie 2014/53/EU, wenn für den vorgesehenen Zweck verwendet werden. Dieses Gerät ist für die Verwendung in den USA, Kanada, and Europäische Union.

Warning! Dies ist eine Einrichtung der Klasse B. Diese Einrichtung kann im Wohnbereich Funkstörungen verursachen. In diesem Fall kann vom Betreiber verlangt werden, angemessene Maßnahmen durchzuführen **Einschränkungen: Frankreich** –(i)-Geräte, die im Band 5150-5250 MHz ist nur für den Innenbereich, um das Risiko von Störungen des mobilen Satelliten-Systeme, die die gleichen Kanäle (ii) Darüber hinaus reduzieren vorbehalten, sollten Benutzer auch darauf hingewiesen werden, dass die Nutzer von Hochleistungs-Radare bezeichnet werden primäre Benutzer (dh d. sie haben Priorität) der Bänder 5 250-5 350 MHz und 5 650-5 850 MHz und dass diese Radargeräte können Störungen und / oder Schäden an LE-LAN-Geräten verursachen.

Laurence Huang



Signature
 Full Name: Laurence Huang
 Position: Hardware Program Manager

Date: June 14, 2022

