



**FCC CFR47 PART 25  
FCC CFR47 PART 15 SUBPART B  
INDUSTRY CANADA RSS-170, RSS-GEN**

**CERTIFICATION TEST REPORT**

**FOR**

**IRIDIUM SATELLITE LLC**

**MODEL NUMBER: 9603**

**FCC ID: Q639603  
IC: 4629A-9603**

**REPORT NUMBER: R12CA20711-FCC-IC**

**ISSUE DATE: May 21, 2012**

*Prepared for*  
**IRIDIUM SATELLITE LLC**

*Prepared by*  
**UL LLC (UL)  
12 LABORATORY DR  
RESEARCH TRIANGLE PARK, NC 27709  
TEL: (919) 549-1400**



**NVLAP LAB CODE 200246**

Revision History

<u>Rev.</u>	<u>Issue Date</u>	<u>Revisions</u>	<u>Revised By</u>
--	5/21/12	Initial Issue	Jim Marley
1.0	6/26/12	Spurious measurement update requested by TCB	Jim Marley

## TABLE OF CONTENTS

<b>1. TEST METHODOLOGY .....</b>	<b>5</b>
<b>2. FACILITIES AND ACCREDITATION.....</b>	<b>5</b>
<b>3. CALIBRATION AND UNCERTAINTY .....</b>	<b>5</b>
3.1. MEASURING INSTRUMENT CALIBRATION .....	5
3.2. SAMPLE CALCULATION.....	5
3.3. MEASUREMENT UNCERTAINTY .....	5
<b>4. EQUIPMENT UNDER TEST .....</b>	<b>6</b>
4.1. DESCRIPTION OF EUT.....	6
4.2. MAXIMUM OUTPUT POWER.....	7
4.3. DESCRIPTION OF AVAILABLE ANTENNAS .....	7
4.4. EMISSIONS DESIGNATOR.....	7
4.5. SOFTWARE AND FIRMWARE.....	7
4.6. WORST-CASE CONFIGURATION AND MODE.....	7
4.7. DESCRIPTION OF TEST SETUP .....	8
<b>5. TEST AND MEASUREMENT EQUIPMENT .....</b>	<b>10</b>
<b>6. ANTENNA PORT TEST RESULTS .....</b>	<b>12</b>
6.1. EMISSIONS.....	12
6.1.1. OUTPUT POWER .....	12
6.1.2. EMISSIONS LIMITATIONS (EMISSIONS MASK) .....	15
6.1.3. CONDUCTED SPURIOUS EMISSIONS.....	22
6.1.4. FREQUENCY STABILITY - TEMPERATURE.....	31
6.1.5. FREQUENCY STABILITY - VOLTAGE.....	33
6.1.6. DUTY CYCLE FACTOR .....	34
<b>7. RADIATED TEST RESULTS .....</b>	<b>36</b>
7.1. LIMITS AND PROCEDURE .....	36
7.2. TRANSMITTER 30-1000 MHz .....	37
7.2.1. RADIATED TRANSMITTER SPURIOUS EMISSIONS .....	37
7.2.1. RADIATED RECEIVER SPURIOUS EMISSIONS / UNINTENTIONAL EMISSIONS .....	39
7.3. TRANSMITTER ABOVE 1 GHz .....	41
7.3.1. RADIATED TRANSMITTER SPURIOUS EMISSIONS .....	41
7.3.2. RADIATED RECEIVER SPURIOUS EMISSIONS / UNINTENTIONAL EMISSIONS .....	48
<b>8. AC POWER LINE CONDUCTED EMISSIONS .....</b>	<b>51</b>
<b>9. MAXIMUM PERMISSIBLE EXPOSURE.....</b>	<b>56</b>

### ATTESTATION OF TEST RESULTS

**COMPANY NAME:** IRIDIUM SATELLITE LLC  
**EUT DESCRIPTION:** FCC Part 25 Transceiver  
**MODEL:** 9603  
**SERIAL NUMBER:** Sample #S12LB082  
**DATE TESTED:** April 19-May 11, 2012

APPLICABLE STANDARDS	
STANDARD	TEST RESULTS
CFR 47 FCC Part 25 (2011)	Pass
CFR 47 FCC Part 15, Subpart B, Class B (2011)	Pass
Industry Canada RSS-170, Issue 2 (March 2011)	Pass
Industry Canada RSS-GEN Issue 3 (Dec 2010)	Pass
ICES-003 Issue 4, Class B (2004)	Pass

UL LLC tested the above equipment in accordance with the requirements set forth in the above standards. All indications of Pass/Fail in this report are opinions expressed by UL LLC based on interpretations and/or observations of test results. Measurement Uncertainties were not taken into account and are published for informational purposes only. The test results show that the equipment tested is capable of demonstrating compliance with the requirements as documented in this report.

**Note:** The results documented in this report apply only to the tested sample, under the conditions and modes of operation as described herein. This document may not be altered or revised in any way unless done so by UL LLC and all revisions are duly noted in the revisions section. Any alteration of this document not carried out by UL LLC will constitute fraud and shall nullify the document. This report must not be used by the client to claim product certification, approval, or endorsement by NVLAP, NIST, any agency of the Federal Government, or any agency of any government.

Approved & Released For UL By:

Tested By:

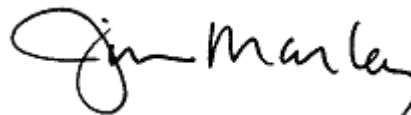

Mark Nolting (Reviewer)  
Staff EMC Engineer  
Underwriters Laboratories, Inc.  
[Mark.nolting@ul.com](mailto:Mark.nolting@ul.com)  
(919)549-1584

Jim Marley (Test Engineer)  
Staff EMC Engineer  
Underwriters Laboratories, Inc.  
[James.r.marley@ul.com](mailto:James.r.marley@ul.com)  
(919)549-1408

## 1. TEST METHODOLOGY

The tests documented in this report were performed in accordance with ANSI C63.4:2003, FCC CFR 47 Part 2, FCC CFR 47 Part 15 Subpart B, RSS-170, and RSS-GEN. ANSI/TIA 603-C:2004 test practices were followed where applicable (including Conducted Power measurements via power meter).

## 2. FACILITIES AND ACCREDITATION

The test sites and measurement facilities used to collect data are located at 12 Laboratory Drive, Research Triangle Park, NC USA.

UL is accredited by NVLAP, Laboratory Code 200246-0. The full scope of accreditation can be viewed at <http://www.nist.gov/nvlap>.

## 3. CALIBRATION AND UNCERTAINTY

### 3.1. MEASURING INSTRUMENT CALIBRATION

The measuring equipment utilized to perform the tests documented in this report has been calibrated in accordance with the manufacturer's recommendations, and is traceable to recognized national standards.

### 3.2. SAMPLE CALCULATION

Where relevant, the following sample calculation is provided:

$$\begin{aligned} \text{Field Strength (dBuV/m)} &= \text{Measured Voltage (dBuV)} + \text{Antenna Factor (dB/m)} + \text{Cable} \\ &\text{Loss (dB)} - \text{Preamp Gain (dB)} \\ 36.5 \text{ dBuV} + 18.7 \text{ dB/m} + 0.6 \text{ dB} - 26.9 \text{ dB} &= 28.9 \text{ dBuV/m} \end{aligned}$$

### 3.3. MEASUREMENT UNCERTAINTY

Where relevant, the following measurement uncertainty levels have been estimated for tests performed on the apparatus:

PARAMETER	UNCERTAINTY
Conducted Disturbance, 0.15 to 30 MHz	± 2.5 dB
Radiated Disturbance, 30 to 1000 MHz	± 3.4 dB

Uncertainty figures are valid to a confidence level of 95%.

## 4. EQUIPMENT UNDER TEST

### 4.1. DESCRIPTION OF EUT

The EUT is a FCC Part 25 Satellite Communications device. The module is mounted to a test board for evaluation and test.

A communications tool, Simple TPI, is used to set the EUT to the intended channel and operating mode for test. The following commands were used:

Transmit mode:

```
etst // enter test mode
uift 00
spay 80 00
seed b9 6a 1a 8a
//next command starts transmitting, Ch1
stch 01 01 04 00 00 07 1C 00 00 00 00 01

abrt // stop transmitting by typing abrt or flip switch to off on Test Interface Card

quit //exits SimpleTPI
```

Transmit commands:

```
CH 1: Stch 01 01 04 00 00 07 1C 00 00 00 00 01 CH117: Stch 0F 0F 04 04 00 07 1C 00 00 00 00 01
CH18: Stch 03 03 04 01 00 07 1C 00 00 00 00 01 CH121: Stch 10 10 04 00 00 07 1C 00 00 00 00 01
CH36: Stch 05 05 04 03 00 07 1C 00 00 00 00 01 CH150: Stch 13 13 04 05 00 07 1C 00 00 00 00 01
CH54: Stch 07 07 04 05 00 07 1C 00 00 00 00 01 CH178: Stch 17 17 04 01 00 07 1C 00 00 00 00 01
CH55: Stch 07 07 04 06 00 07 1C 00 00 00 00 01 CH240: Stch 1E 1E 04 07 00 07 1C 00 00 00 00 01
CH75: Stch 0A 0A 04 02 00 07 1C 00 00 00 00 01
```

Continuous RX mode:

```
Etst
Uift 00
Schn 01 01 //receive on CH1
Srfp 04 //start receive

Srfp 00 //command to stop receive, or flip off switch
```

SCHN command is the channel number in hex repeated twice. For example:  
CH1 = schn 01 01, CH121 = schn 79 79, and CH240 = schn F0 F0

For immunity testing:

```
Etst
Uift 01
Spay 48 00
Stch 01 01 04 00 00 13 88 00 00 00 00 01 //channel 1
```

## 4.2. MAXIMUM OUTPUT POWER

The transmitter has a maximum average conducted output power as follows:

RF Output Power (conducted) - FCC Part 25.204(a)

Frequency Range (MHz)	Mode	Output Power (dBm)	Output Power (mW)
1616 – 1626	Power Meter (ANSI TIA 603-C)	31.41 (antenna port)	1383.566 (antenna port)

EIRP (with maximum gain antenna attached)

Frequency Range (MHz)	Mode	Output Power (dBm)	Output Power (mW)
1616 – 1626	Power Meter (ANSI TIA 603-C)	34.41 (EIRP)	2760.578 (EIRP)

## 4.3. DESCRIPTION OF AVAILABLE ANTENNAS

The radio utilizes a monopole antenna with a maximum gain as table below;

Frequency Range (MHz)	Antenna Gain (dBi)	Antenna Gain (numeric)
1616 - 1626	3.0	2.0

## 4.4. EMISSIONS DESIGNATOR

The emissions designator for this device is 41K7Q7D.

## 4.5. SOFTWARE AND FIRMWARE

The EUT was tested with the firmware installed in the device as provided by the manufacturer. Test utility software for the laptop was provided to enable the operating channel to be changed as necessary during the test.

## 4.6. WORST-CASE CONFIGURATION AND MODE

The EUT was tested as an external module. EUT is attached to a laptop computer via USB port.

Only one data rate, modulation type is planned for this device. Random data pattern is applied

For Radiated Spurious Emissions, the worst-case arrangement is determined by testing the EUT in each of three orthogonal axes (flat, side, upright). This arrangement is used for testing low and high channels.

## 4.7. DESCRIPTION OF TEST SETUP

### SUPPORT EQUIPMENT

This device is mounted to a digital interface board and connected to DC power supply power source. Antenna port is connected to impedance-matched load. For unintentional radiator tests the device is attached to a serial cable.

### I/O CABLES

The EUT is attached to the host device by serial port cable.

### TEST SETUP

The EUT and support laptop are arranged as shown in the setup photos. For Antenna port tests, the antenna is removed and connected directly to the spectrum analyzer as shown in the setup diagram.



**SETUP DIAGRAM FOR TESTS**

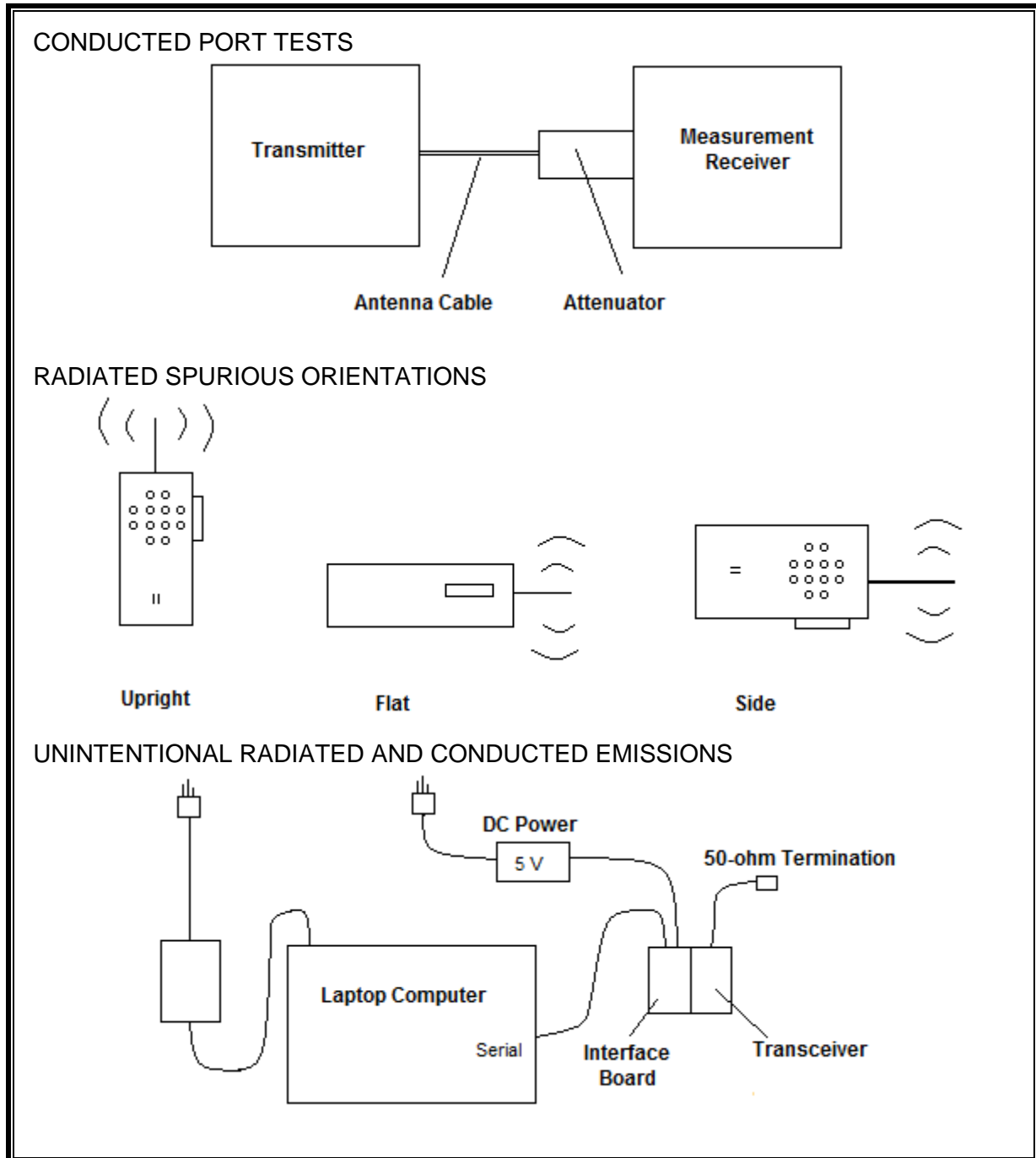

## 5. TEST AND MEASUREMENT EQUIPMENT

The following test and measurement equipment was utilized for the tests documented in this report:

### Radiated Emissions/Radiated Spurious

Equip. ID	Description	Manufacturer	Model Number	Last Cal.	Next Cal.
	<b>30-1000 MHz</b>				
AT0021	Biconical Antenna, 30 to 300 MHz	Schaffner-Chase EMC Ltd.	VBA6106A	2011-05-31	2012-05-31
AT0030	Log-periodic Antenna, 200 MHz to 1000 MHz	Schaffner	UPA6109	2011-06-03	2012-06-30
	<b>1-18 GHz</b>				
AT0032	Horn Antenna 1 to 18 GHz	EMC Test Systems	3115	2012-10-31	2013-10-31
	<b>Cables and Pre-Amps</b>				
SAC_C (Biconical 3m location)	(1) ATA084: Attenuator (2) ATA061: Amplifier (3) ATA167: Cable (4) ATA221: Cable (5) ATA229: DC Bias Tee (6) ATA199: Cable	(1) Pasternack (2) Miteq (3) Eupen (4) Micro-Coax (5) Miteq (6) Micro-Coax	(1) PE7002-6 (2) AM-3A-000110-N (3) CMS/RG 214 (4) UFA210A-0-6000- 50U-50U (5) BT2000-C (6) UFB293C-0-0720- 5GU50U)	2011-08-31	2012-08-31
SAC_D (Log- Periodic 3m location)	(1) ATA085: Attenuator (2) ATA110: Amplifier (3) ATA225: Cable (4) ATA189: Cable (5) ATA115: DC Bias Tee (6) ATA198: Cable	(1) Pasternack (2) Miteq (3) Eupen (4) UL (5) Miteq (6) Micro-Coax	(1) PE7002-6 (2) AM-3A-000110-N (3) CMS/RG 214 (4) RG-214 (5) AM-1523-7687 (6) UFB293C-0-0720- 5GU50U)	2011-08-31	2012-08-31
SAC_E_ HORN (1-18 GHz)	(1) ATA144: Amplifier (2) CBL005: Cable (3) CBL002: Cable (4) ATA199: Cable	(1) Miteq (2) MegaPhase (3) MegaPhase (4) Micro-Coax	(1) AFS42-00101800-25- N-42MF (2) GC29-NKNK-264 (3) EM18-NKNK-600 (4) UFB293C-0-0720- 5GU50U)	2011-09-14	2012-09-30
	<b>Receiver &amp; Software</b>				
SAR003	Spectrum Analyzer / Receiver	Rohde & Schwarz	1088.7490K40	2011-08-03	2012-08-31
SOFTEMI	EMI Software	UL	Version 9.5	NA	NA
	<b>Additional Equipment</b>				
-	10dB Attenuator (Qty 3)	-	N-male to N-female	(Note 1)	(Note 1)

Note 1: Attenuator loss confirmed prior to measurements.

Conducted Power / Conducted Spurious Emissions - Voltage

Equipment ID	Description	Manufacturer	Model Number	Last Cal.	Next Cal.
	<b>Conducted Power / Spurious</b>				
SA0015	EMI Test Receiver 9kHz-7GHz	Rohde & Schwarz	ESCI 7	2012-01-30	2013-01-31
-	Attenuators, 50-ohm,10dB	Pasternack	N-Male to N-Female	2011-08-31	2012-08-31

Conducted Disturbance Emissions - Voltage

Equipment ID	Description	Manufacturer	Model Number	Last Cal.	Next Cal.
	<b>Equipment – Ground Plane E</b>				
SA0015	EMI Test Receiver 9kHz-7GHz	Rohde & Schwarz	ESCI 7	2012-01-30	2013-01-31
ATA016	Coaxial cable, 20 ft., BNC -male to BNC-male	UL	RG-223	2011-08-31	2012-08-31
HI0069	Temp/Humid/Pressure Meter	Cole-Parmer	99760-00	2011-06-16	2012-06-30
SOFTEMI	EMI Software	UL	Version 9.5	NA	NA
	<b>Transient Limiter</b>				
ATA508	Transient Limiter, 0.009 to 100 MHz	Electro-Metrics	EM 7600	2011-08-31	2012-08-31
	<b>LISNs</b>				
ATA027	LISN, 50-ohm/50-uH, 25A	Solar Electronics	9629-50-TS-25-BNC	2011-08-31	2012-08-31
ATA028	LISN, 50-ohm/50-uH, 25A	Solar Electronics	9629-50-TS-25-BNC	2011-08-31	2012-08-31

## 6. ANTENNA PORT TEST RESULTS

### 6.1. EMISSIONS

#### 6.1.1. OUTPUT POWER

##### LIMITS

FCC §25.204 (a)

##### TEST PROCEDURE

Power Meter (Average) was measured using a power meter with average (thermal) detection per EIA/TIA 603-C. As device could not be set to continuously transmit, a Duty Cycle correction was added to compensate for carrier off intervals.

##### RESULTS

##### Power Meter (Average)

Channel	Power Meter Level <sup>1</sup> - Avg (dBm)	Transmit Antenna Gain (dBi)	Duty Cycle Factor (dB)	Carrier Power Peak EIRP (dBm)	Carrier Power EIRP Limit (dBm)
1	20.9	3.0	10.35	34.25	+40
75	20.86	3.0	10.35	34.21	+40
150	20.91	3.0	10.35	34.26	+40
240	21.06	3.0	10.35	34.41	+40

Note 1: Meter measurement includes 30.5 dB offset for external attenuators and attaching cable.  
Maximum average power = 31.41dBm (1.383W) conducted, or with antenna gain 34.41dBm (2.760W) EIRP.

Peak Power (Spectrum Analyzer) - Conducted

OUTPUT POWER – CHANNEL 1

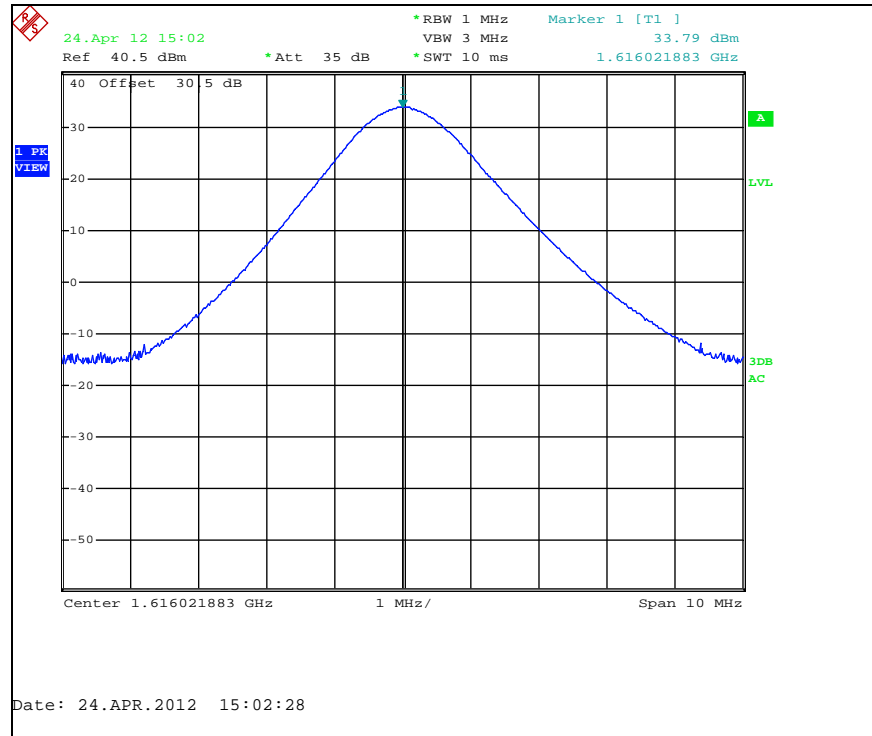

Note 1: Measurements include 30.5 dB offset for external attenuators and attaching cable

BANDWIDTH CHANNEL 75

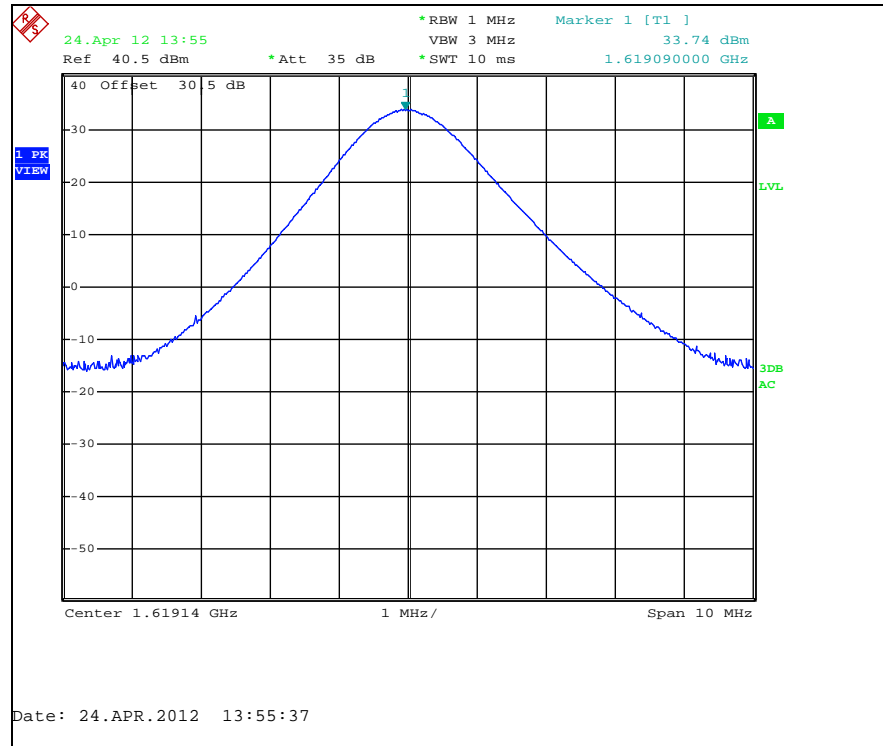

### BANDWIDTH CHANNEL 150

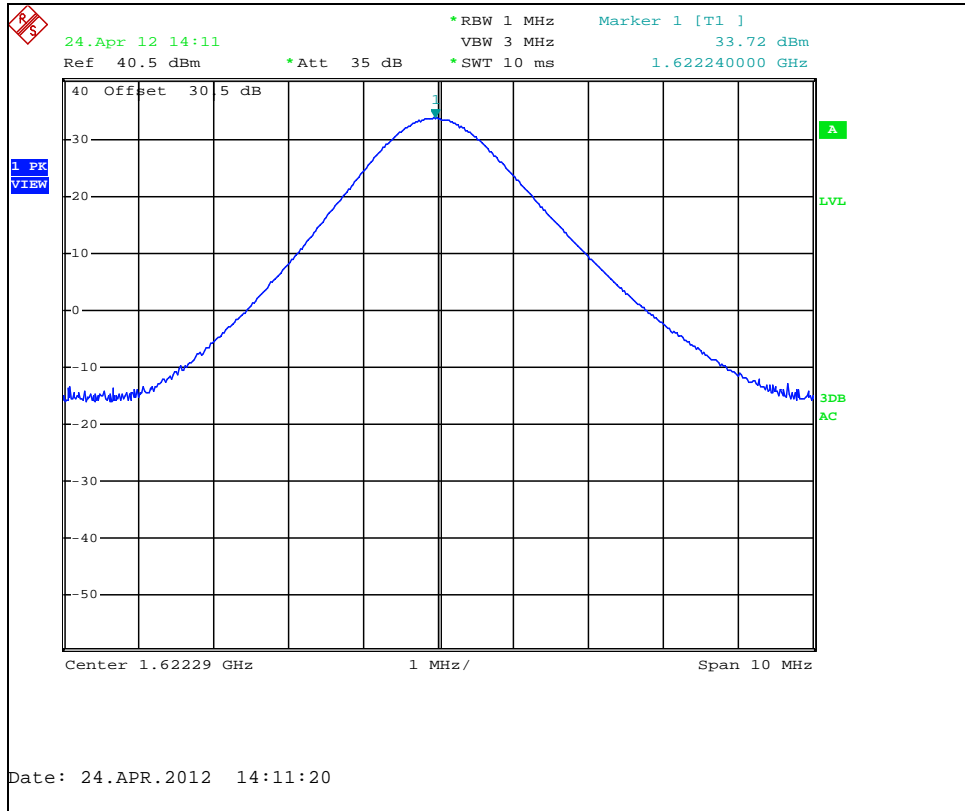

### BANDWIDTH CHANNEL 240

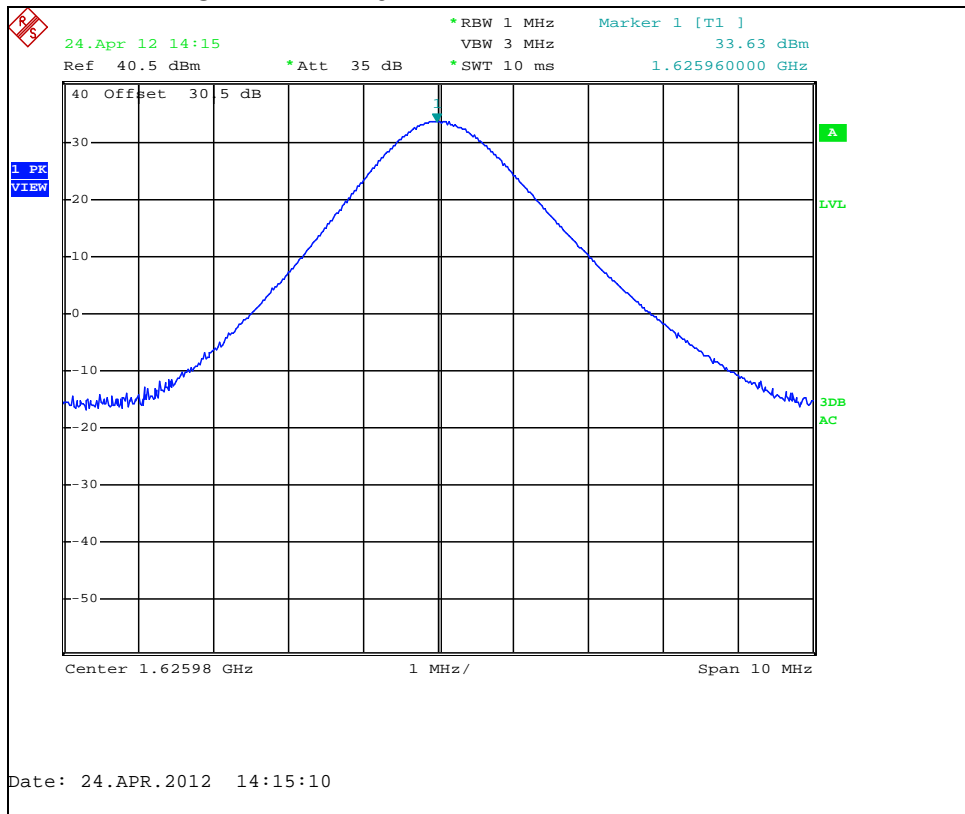

**6.1.2. EMISSIONS LIMITATIONS (EMISSIONS MASK)**

**LIMITS**

FCC §25.202 (f)

RSS-170 Clause 5.4.3

**TEST PROCEDURE**

Emissions mask was measured on each of four channels. The antenna port was connected to input of the spectrum analyzer. The resolution bandwidth is set to 3 kHz, video bandwidth to 30 kHz. The highest points are marked at each emissions step to demonstrate compliance. The emissions mask is as follows:

Frequency removed from channel center by:	Minimum signal reduction
0 to 50%	In channel
50 to 100%	-25 dBc
100 to 250%	-35 dBc
More than 250%	-13 dBm

**RESULTS**

Channel	Output Power (dBm)	Frequency Offset (% of channel)	Max Measured <sup>1</sup> (dBm)	Limit (dBm)
1	31.25	More than -250%	-34.23	-13
		-100% to -250%	-15.51	-3.75
		-50% to -100%	-1.27	+6.25
		+50% to +100%	1.81	+6.25
		+100% to +250%	-15.71	-3.75
		More than +250%	-34.26	-13
75	31.21	More than -250%	-33.50	-13
		-100% to -250%	-15.88	-3.79
		-50% to -100%	-0.60	+6.21
		+50% to +100%	-0.17	+6.21
		+100% to +250%	-15.68	-3.79
		More than +250%	-35.60	-13
150	31.26	More than -250%	-33.63	-13
		-100% to -250%	-14.35	-3.74
		-50% to -100%	-4.55	+6.26
		+50% to +100%	-5.34	+6.26
		+100% to +250%	-17.13	-3.74
		More than +250%	-35.42	-13
240	31.41	More than -250%	-32.50	-13
		-100% to -250%	-16.44	-3.59
		-50% to -100%	-6.91	+6.41
		+50% to +100%	-5.41	+6.41
		+100% to +250%	-17.28	-3.59
		More than +250%	-33.13	-13

<sup>1</sup> Includes 4kHz/3kHz Bandwidth Correction Factor (1.2 dB)

### EMISSIONS MASK – CHANNEL 1 (50-100% Removed from Channel, -25 dBc)

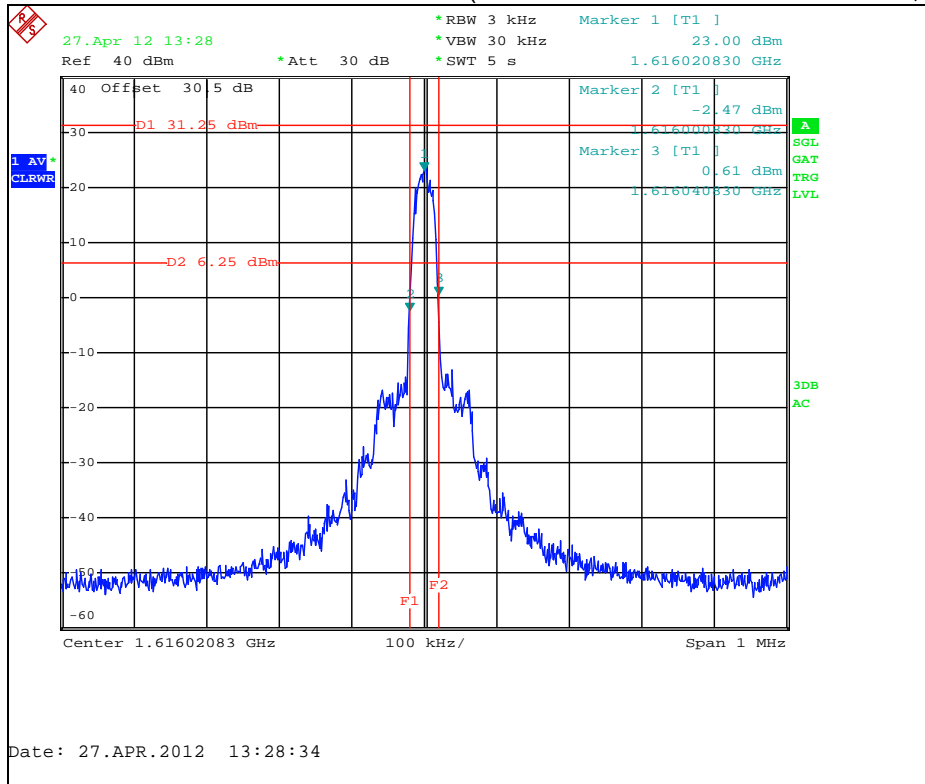

Note: Amplitude Offset factor including attaching cable loss and attenuator is included.

### EMISSIONS MASK – CHANNEL 1 (100-250% Removed from Channel, -35 dBc)

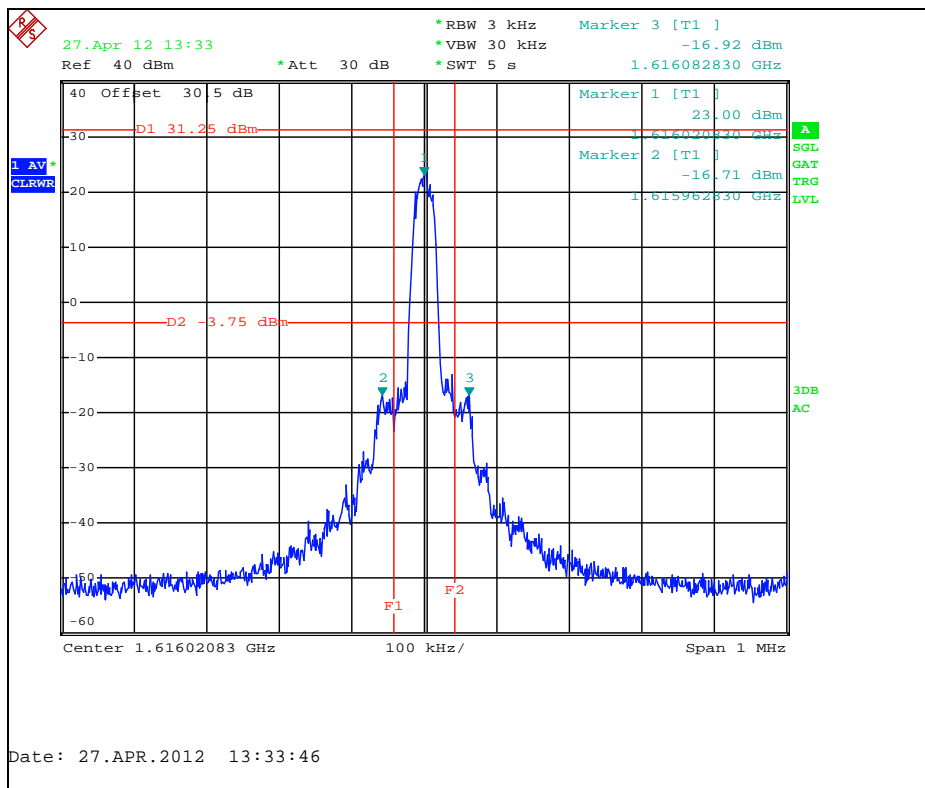



### EMISSIONS MASK – CHANNEL 1 (More than 250% Removed from Channel, -13 dBm)

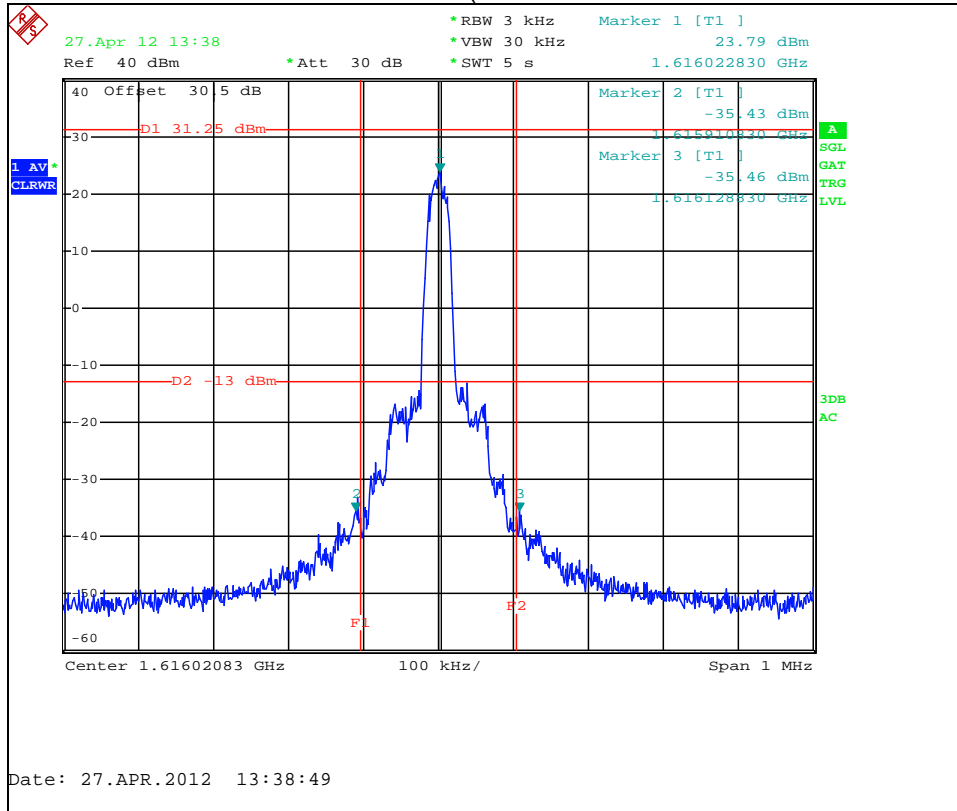

### EMISSIONS MASK – CHANNEL 75 (50-100% Removed from Channel, -25 dBc)

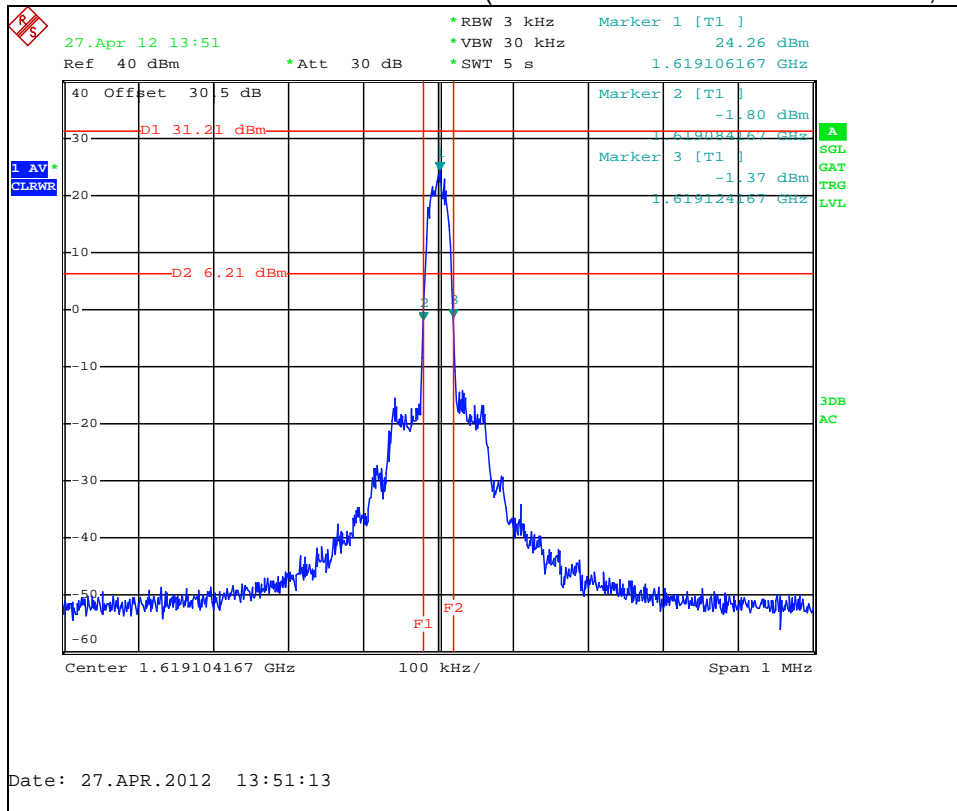

EMISSIONS MASK – CHANNEL 75 (100-250% Removed from Channel, -35 dBc)

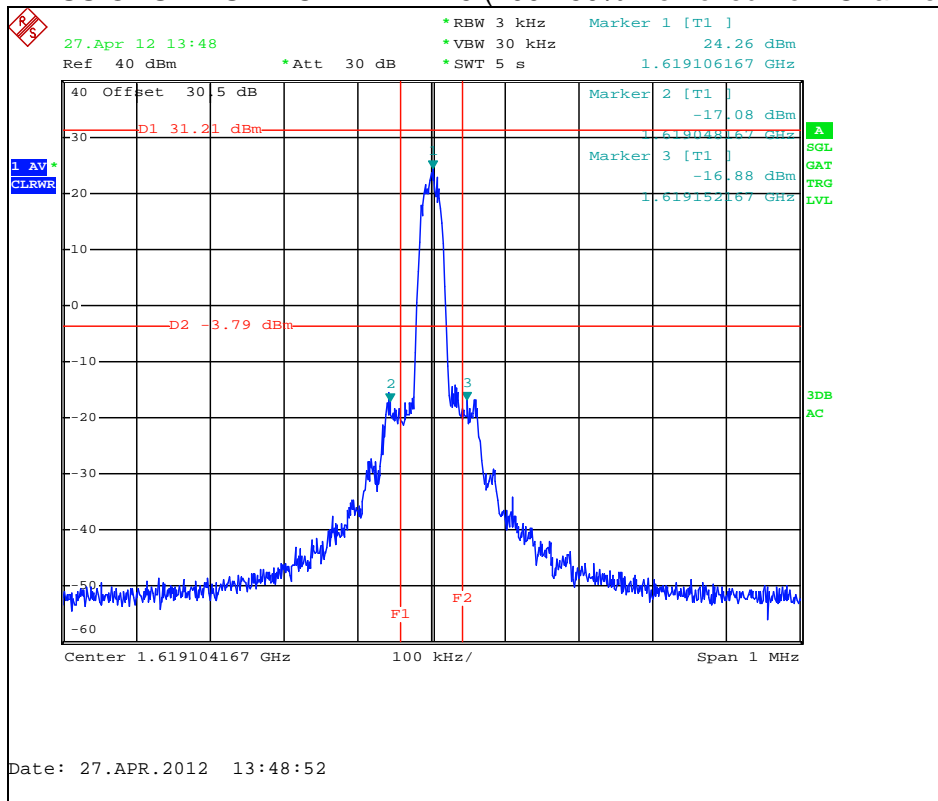

EMISSIONS MASK – CHANNEL 75 (More than 250% Removed from Channel, -13 dBm)

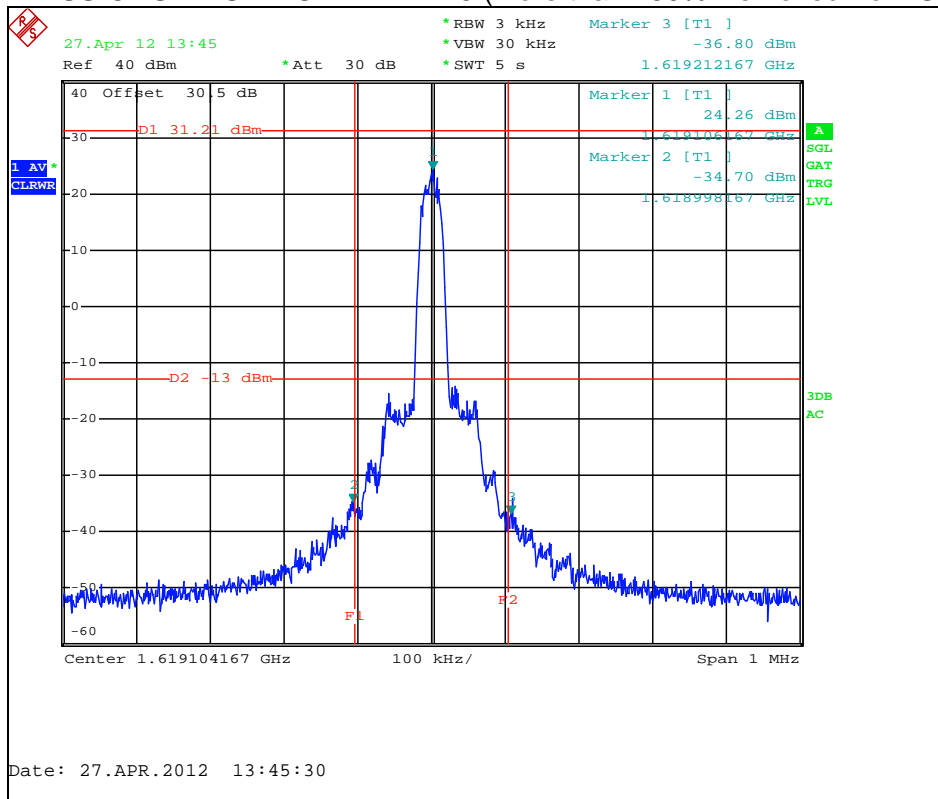

### EMISSIONS MASK – CHANNEL 150 (50-100% Removed from Channel, -25 dBc)

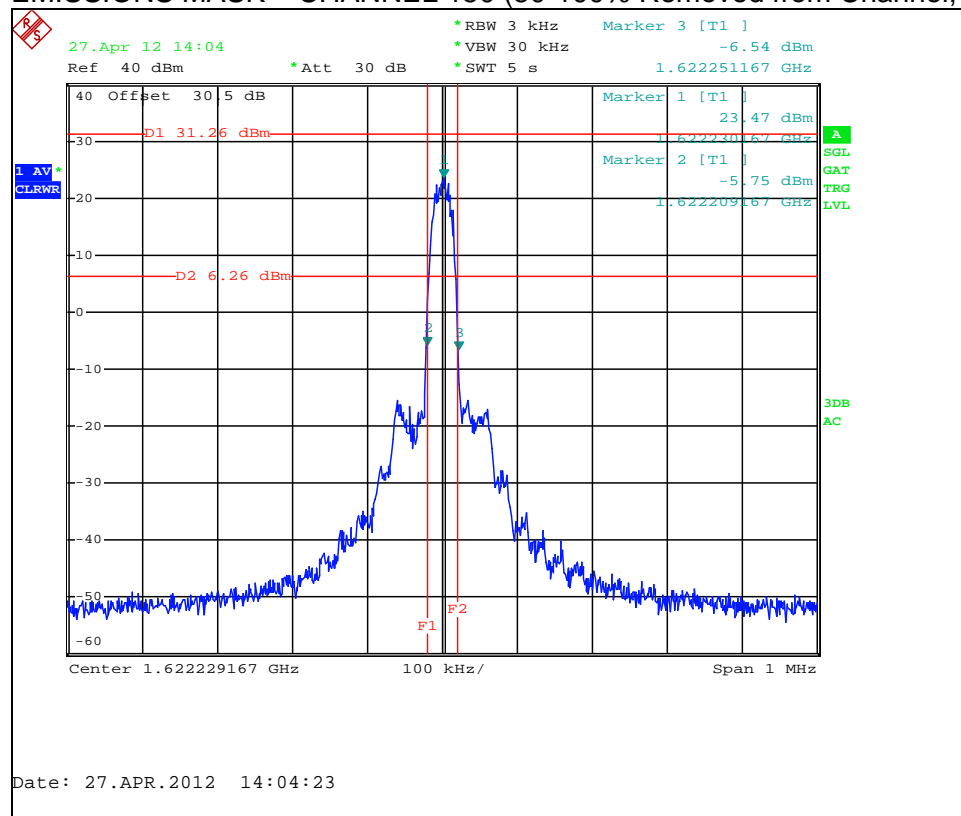

### EMISSIONS MASK – CHANNEL 150 (100-250% Removed from Channel, -35 dBc)

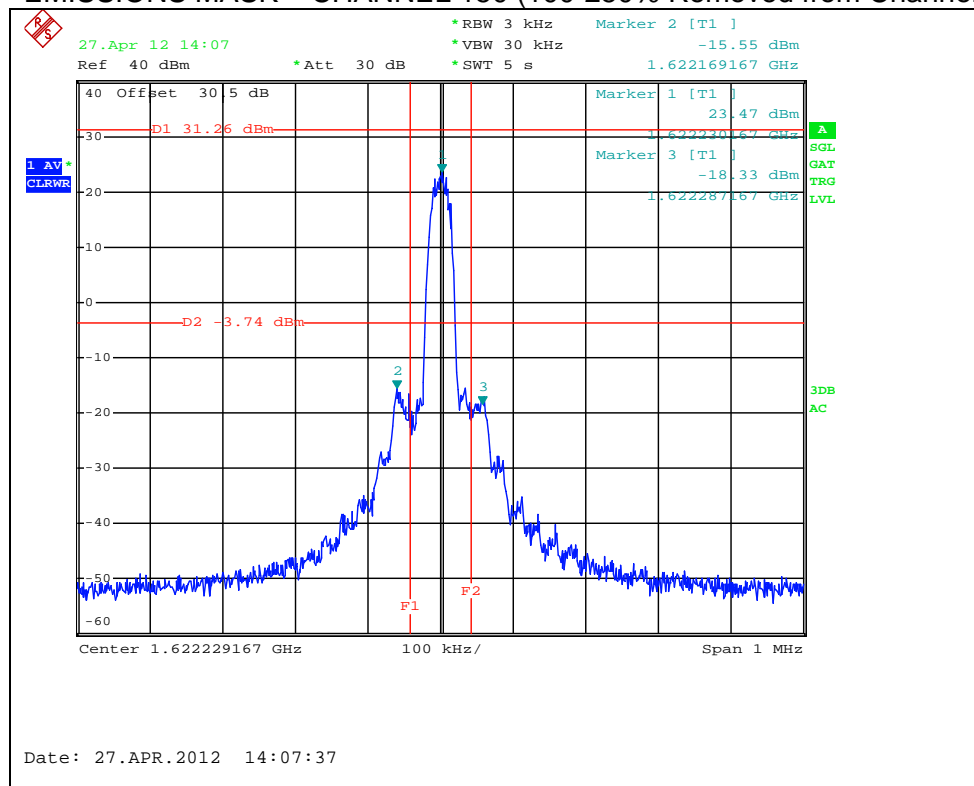

EMISSIONS MASK – CHANNEL 150 (More than 250% Removed from Channel, -13 dBm)

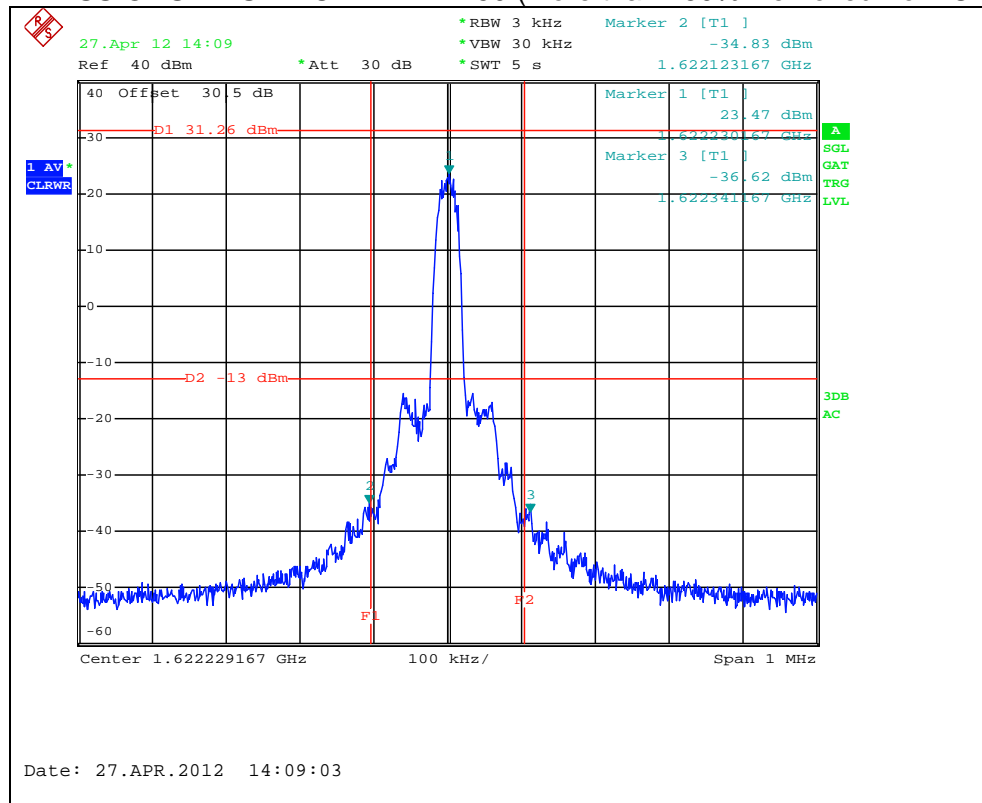

EMISSIONS MASK – CHANNEL 240 (50-100% Removed from Channel, -25 dBc)

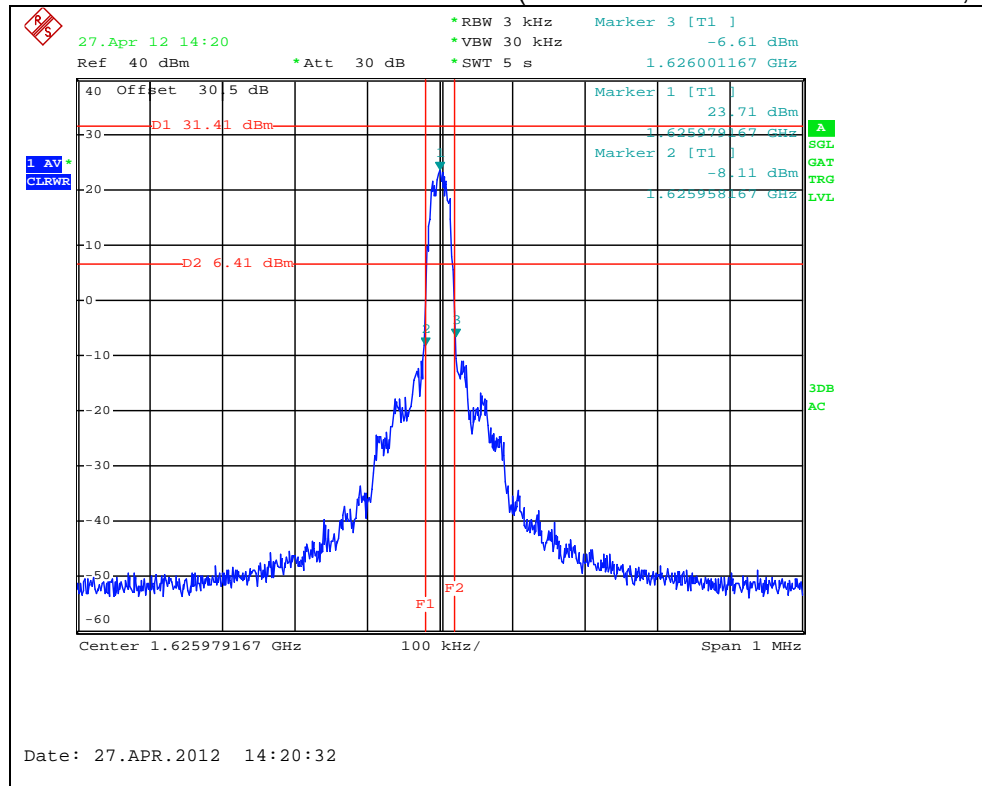

EMISSIONS MASK – CHANNEL 240 (100-250% Removed from Channel, -35 dBc)

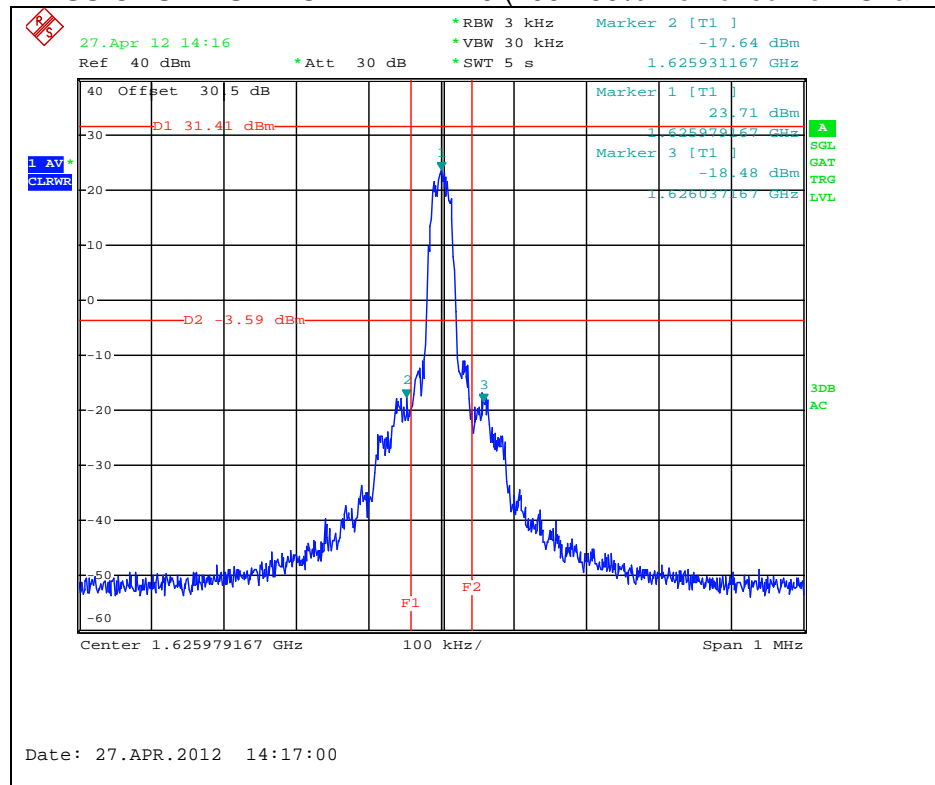

EMISSIONS MASK – CHANNEL 240 - (More than 250% Removed from Channel, -13 dBm)

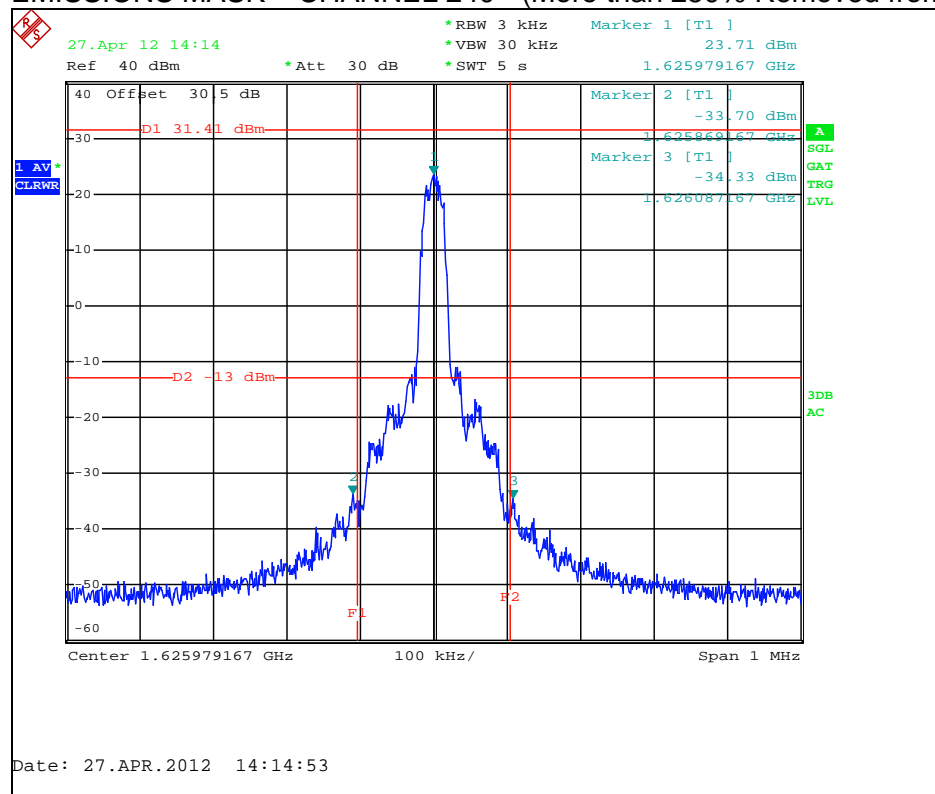

### 6.1.3. CONDUCTED SPURIOUS EMISSIONS

#### LIMITS

FCC Parts 25.202 (f) and 25.216.

Industry Canada RSS-170 Clause 5.4.3.1 and 5.4.3.2.1

#### TEST PROCEDURE

Measurement results are peak detection, except for reduced limits between 1559 and 1610 MHz where the measurements are average detection. Limit, on any frequency removed from the assigned frequency by more than 250% of the authorized bandwidth is attenuated at least:

$43 + \text{Log}(P_{\text{watts}})$  dB, or -13 dBm

Preliminary measurements are performed at wider bandwidths than 4kHz to identify significant emissions. A final measurement at 4kHz RBW is performed for each emission within 20 dB of the spurious limit.

#### RESULTS

Conducted Spurious Emissions = Spectrum Analyzer Level + Cable Loss + Attenuator Loss

Note: Transmit Spurious Emissions between 1559 and 1610 MHz shown to comply with Part 25 reduced emissions limit of -70dBW (-40dBm) and RSS-170 limit of -70dBW/MHz.

**RESULTS**

**CONDUCTED SPURIOUS EMISSIONS – CHANNEL 1 (0.15 - 30 MHz)**

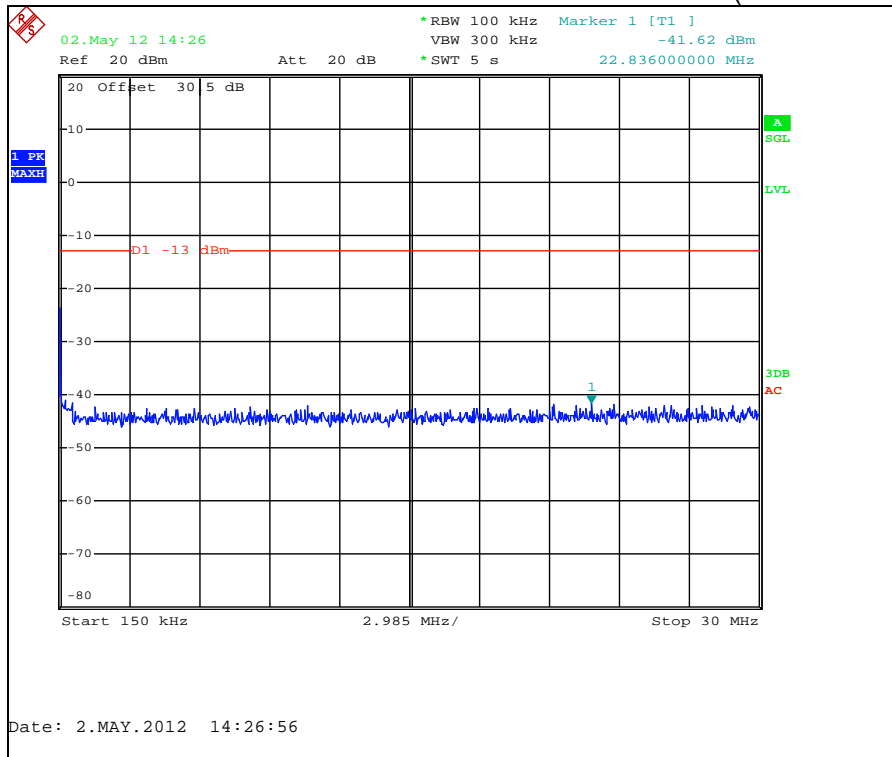

**CONDUCTED SPURIOUS EMISSIONS – CHANNEL 1 (30-1000 MHz)**

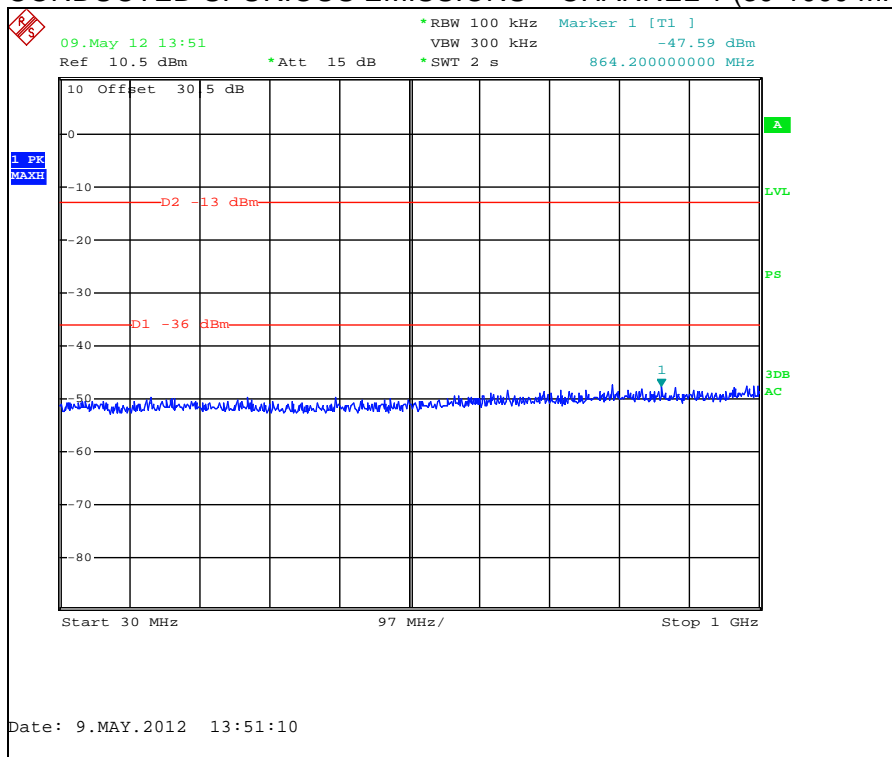

### CONDUCTED SPURIOUS EMISSIONS – CHANNEL 1 (1000 - 1559 MHz)

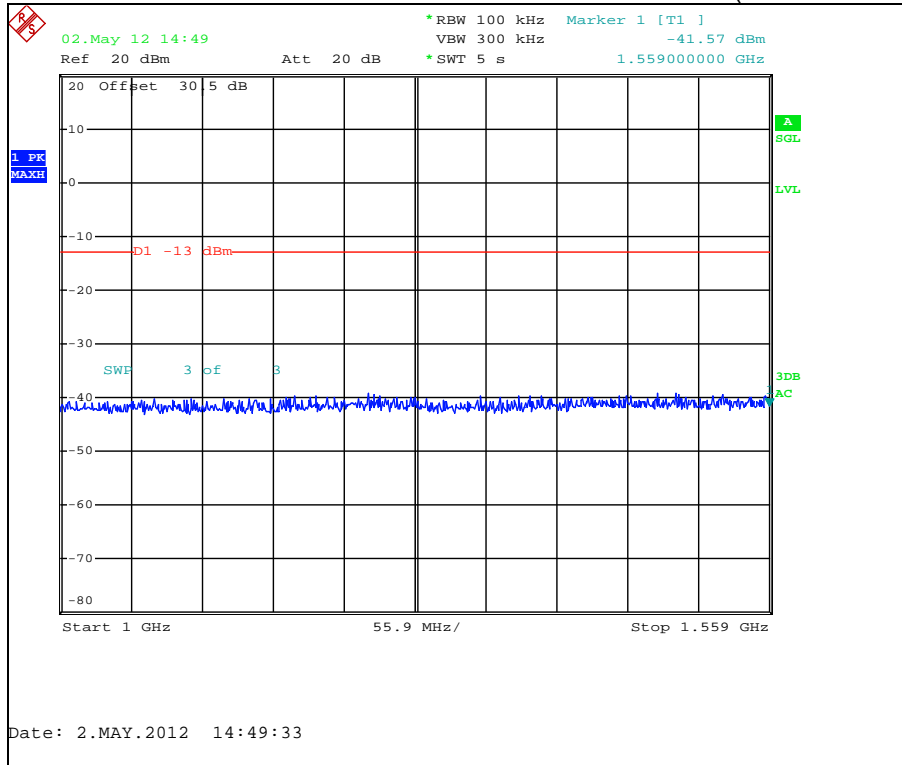

### CONDUCTED SPURIOUS EMISSIONS – CHANNEL 1 (1559-1610 MHz)

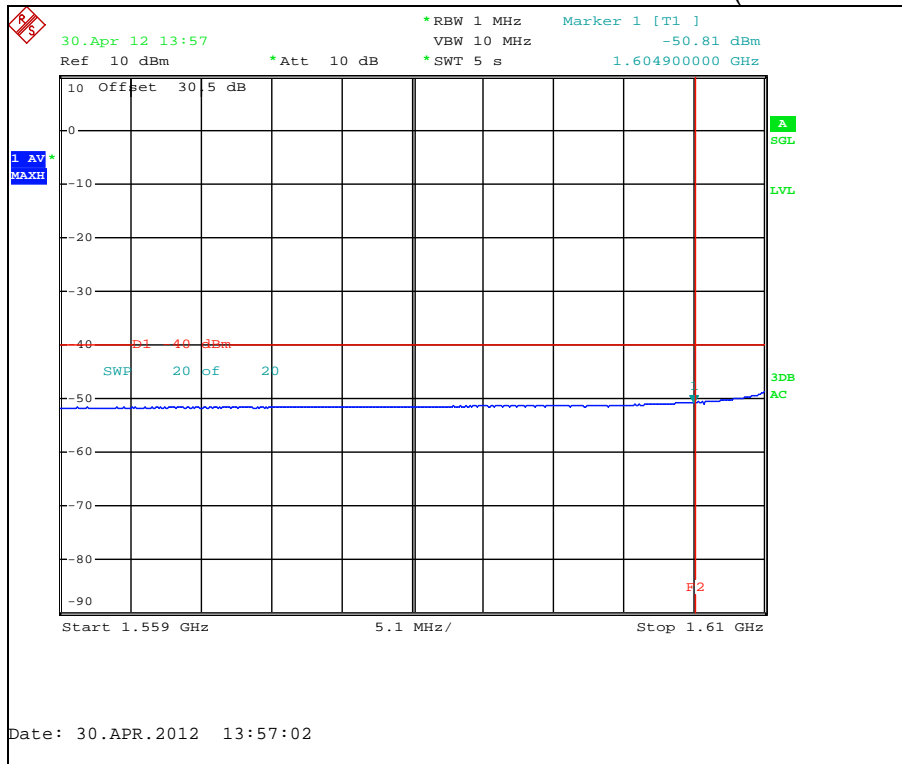



CONDUCTED SPURIOUS EMISSIONS – CHANNEL 1 (1628 - 7000 MHz)

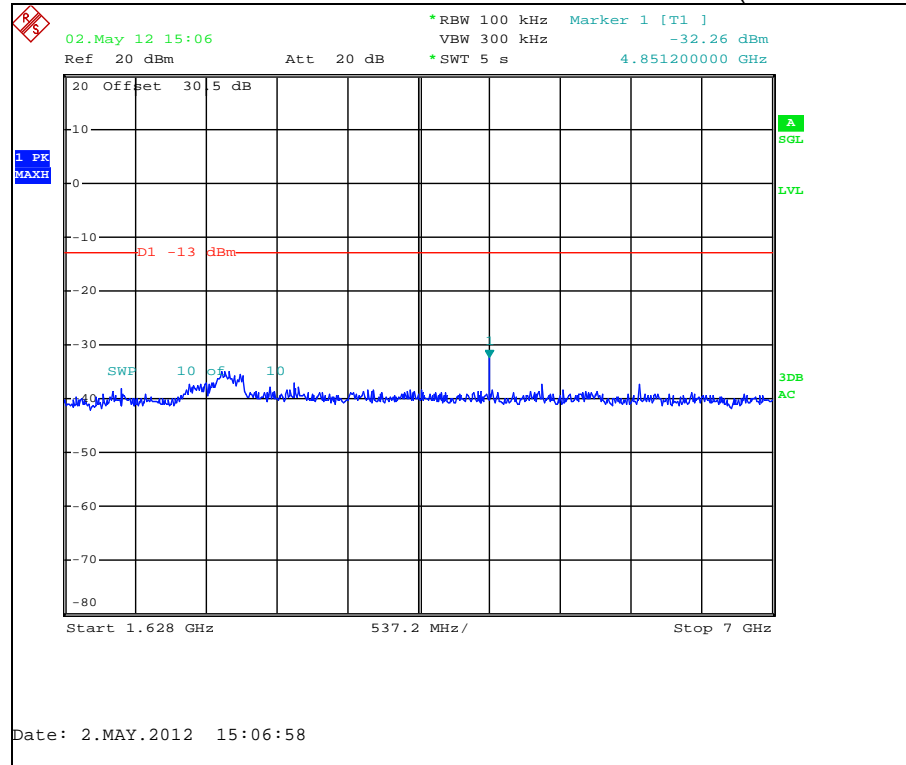

CONDUCTED SPURIOUS EMISSIONS – CHANNEL 1 (7-16.3 GHz)

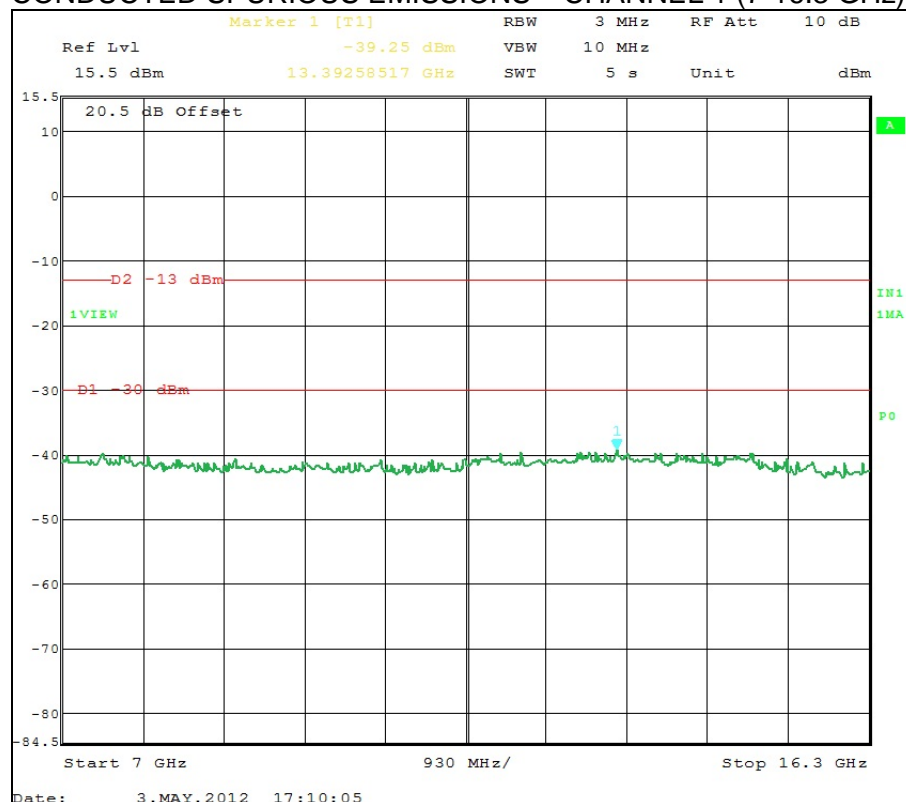

Note: FCC Part 25 Limit is -13dBm.

CONDUCTED SPURIOUS EMISSIONS – 4kHz RBW MEASUREMENT at 4848 MHz.

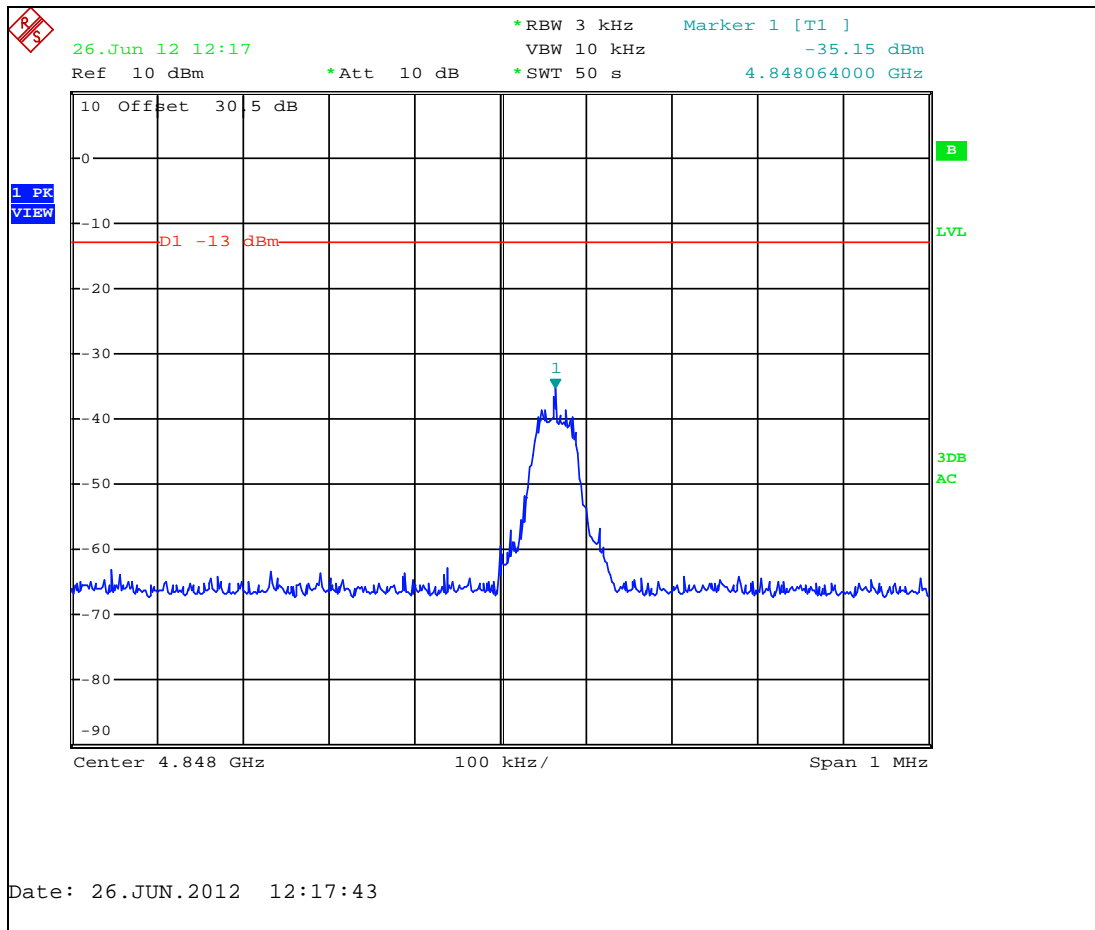

Frequency Measured (MHz)	Conducted Emission @3kHz RBW (dBm)	Bandwidth Correction (4kHz/3kHz) (dB)	Corrected Emission @4kHz RBW (dBm)	Conducted Spurious Limit (dBm)
4848.064	-35.15	1.2	-33.95	-13

### CONDUCTED SPURIOUS EMISSIONS – CHANNEL 240 (0.15 - 30 MHz)

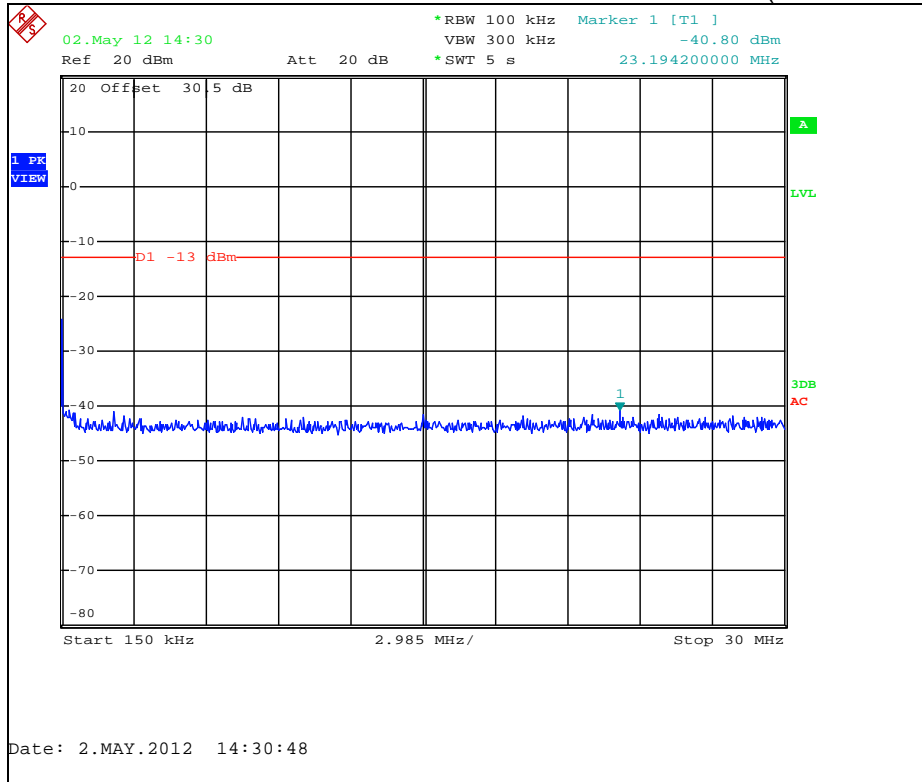

### CONDUCTED SPURIOUS EMISSIONS – CHANNEL 240 (30-1000 MHz)

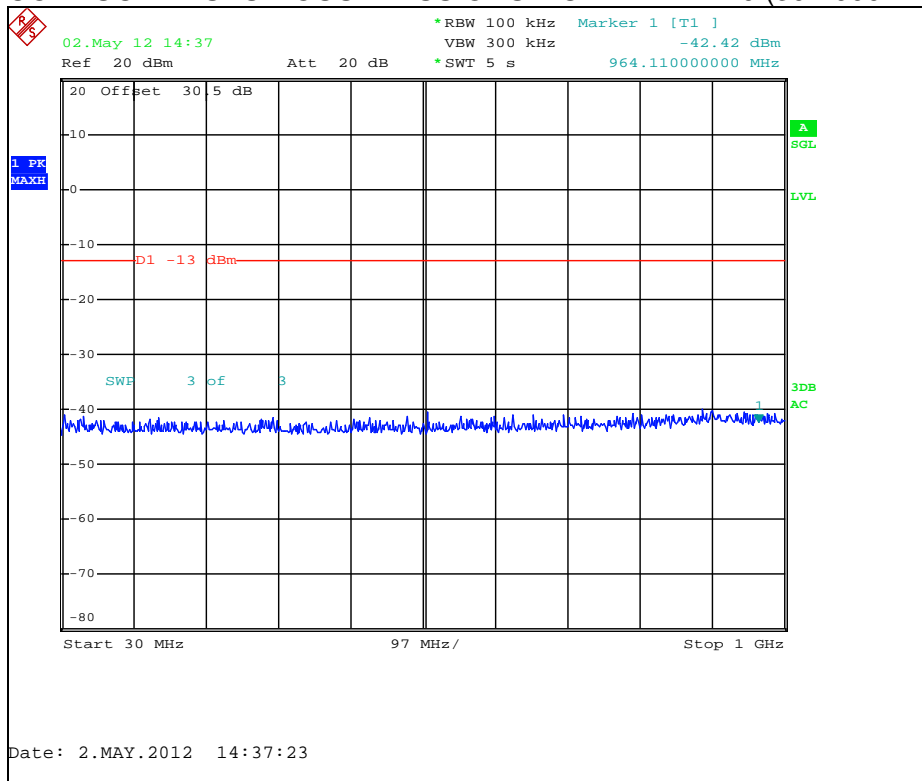

### CONDUCTED SPURIOUS EMISSIONS – CHANNEL 240 (1000 - 1559 MHz)

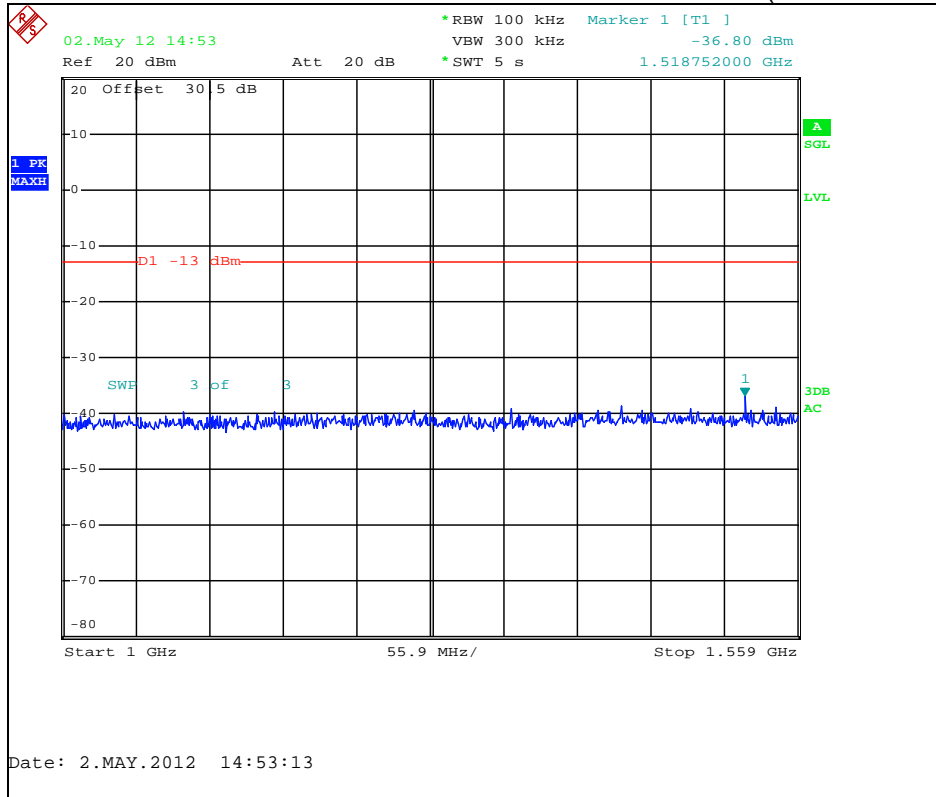

### CONDUCTED SPURIOUS EMISSIONS – CHANNEL 240 (1559-1610 MHz)

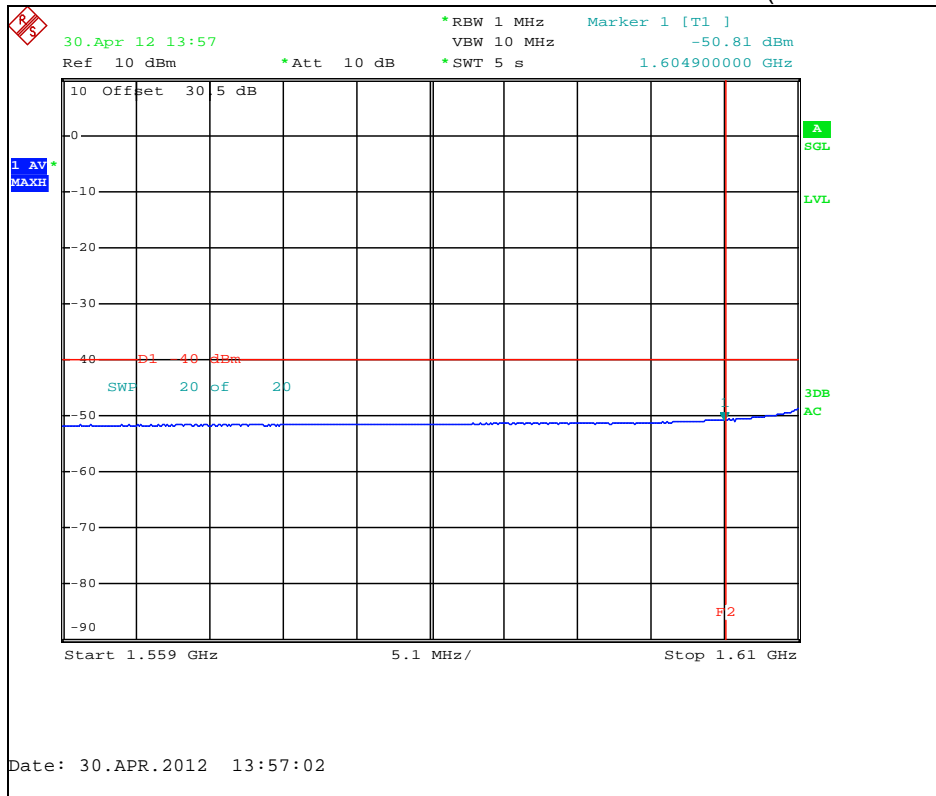

CONDUCTED SPURIOUS EMISSIONS – CHANNEL 240 (1628 - 7000 MHz)

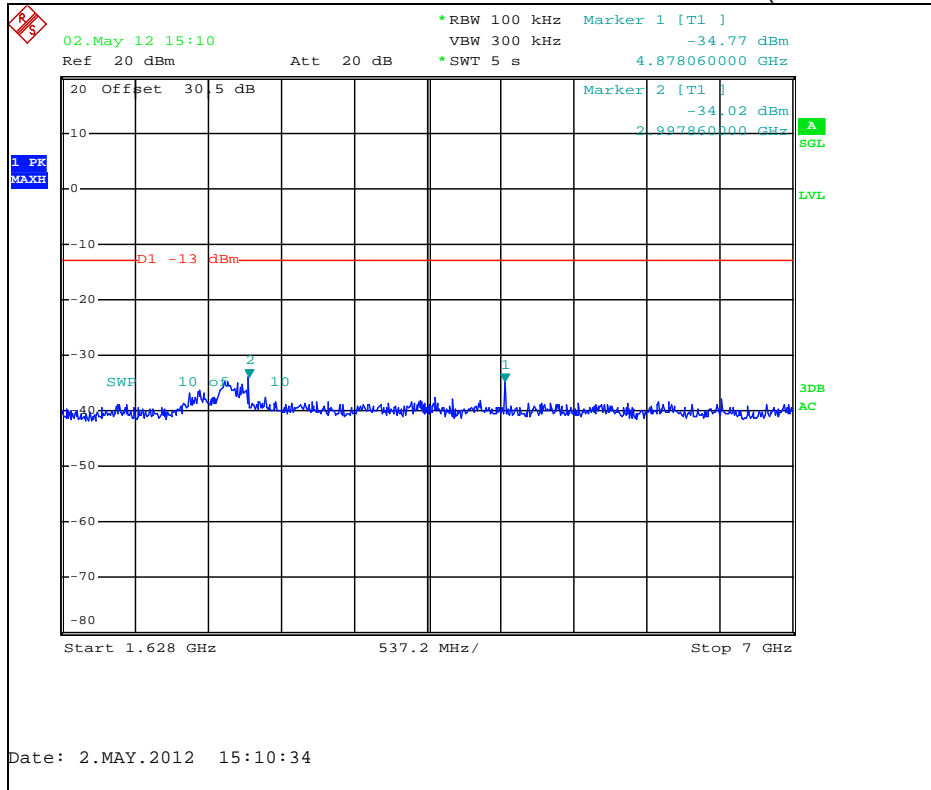

CONDUCTED SPURIOUS EMISSIONS – CHANNEL 240 (7-16.3 GHz)

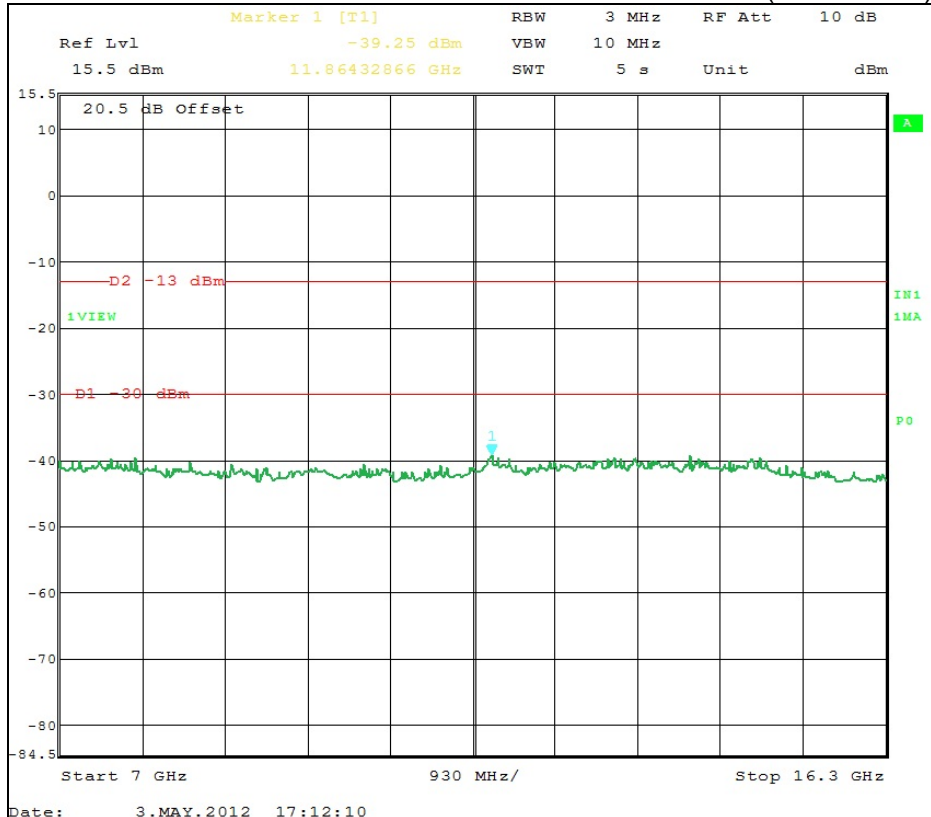

Note: FCC Part 25 Limit is -13dBm.

CONDUCTED SPURIOUS EMISSIONS – 4 kHz RBW MEASUREMENT at 4878 MHz.

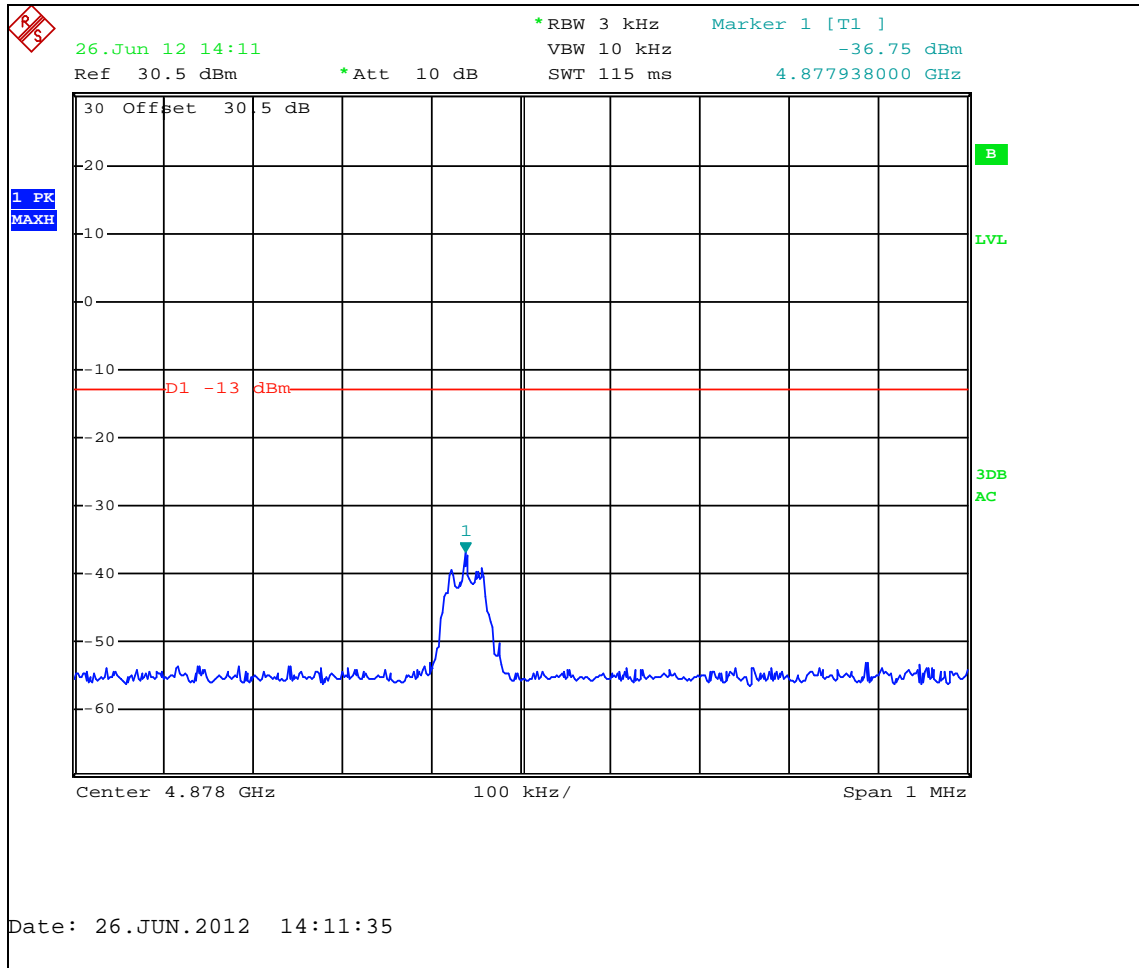

Frequency Measured (MHz)	Conducted Emission @3kHz RBW (dBm)	Bandwidth Correction (4kHz/3kHz) (dB)	Corrected Emission @4kHz RBW (dBm)	Conducted Spurious Limit (dBm)
4848.064	-36.75	1.2	-35.55	-13

### 6.1.4. FREQUENCY STABILITY - TEMPERATURE

#### LIMITS

FCC Part 25.202 (d)  
 +/- 10ppm (0.001%)

RSS-170 Clause 5.2  
 +/- 2.5ppm Mobile Earth Station (0.00025%)

#### TEST PROCEDURE

Peak output power was measured on each of four channels. The unit was placed into test mode and set to operate at maximum power, random modulation. The analyzer is set to max hold at each temperature and channel. Peak frequency is recorded at each temperature.

Operating temperature range defined by the manufacturer as -30°C to +70°C.

#### RESULTS

Temp (C°)	Channel 1	
	Center Frequency Measured (MHz)	Error (ppm)
Center	1616.020833	-
Ambient (+25°)	1616.021033	0.124 ppm
-30°	1616.021533	0.433 ppm
-20°	1616.021933	0.680 ppm
-10°	1616.021983	0.711 ppm
0°	1616.021733	0.557 ppm
+10°	1616.021633	0.495 ppm
+20°	1616.021383	0.340 ppm
+30°	1616.021183	0.216 ppm
+40°	1616.020983	0.093 ppm
+50°	1616.021033	0.124 ppm
+60°	1616.020833	0.000 ppm
+70°	1616.020683	-0.093 ppm

Temp (C°)	Channel 75	
	Center Frequency Measured (MHz)	Error (ppm)
Center	1619.104166	-
Ambient (+25°)	1619.104616	0.278 ppm
-30°	1619.105166	0.618 ppm
-20°	1619.105566	0.865 ppm
-10°	1619.105366	0.741 ppm
0°	1619.105066	0.556 ppm
+10°	1619.105016	0.525 ppm
+20°	1619.104816	0.401 ppm
+30°	1619.104666	0.309 ppm
+40°	1619.104516	0.216 ppm
+50°	1619.104466	0.185 ppm
+60°	1619.104266	0.062 ppm
+70°	1619.103916	-0.155 ppm

Temp (C°)	Channel 150	
	Center Frequency Measured (MHz)	Error (ppm)
Center	1622.229166	-
Ambient (+25°)	1622.229816	0.401 ppm
-30°	1622.230016	0.524 ppm
-20°	1622.230416	0.771 ppm
-10°	1622.230066	0.555 ppm
0°	1622.229966	0.493 ppm
+10°	1622.229816	0.401 ppm
+20°	1622.229616	0.278 ppm
+30°	1622.229466	0.185 ppm
+40°	1622.229416	0.154 ppm
+50°	1622.229116	-0.031 ppm
+60°	1622.228966	-0.123 ppm
+70°	1622.228866	-0.185 ppm

Temp (C°)	Channel 240	
	Center Frequency Measured (MHz)	Error (ppm)
Center	1625.979166	-
Ambient (+25°)	1625.979716	0.338 ppm
-30°	1625.980116	0.584 ppm
-20°	1625.980416	0.768 ppm
-10°	1625.980116	0.584 ppm
0°	1625.979916	0.461 ppm
+10°	1625.979566	0.246 ppm
+20°	1625.979566	0.246 ppm
+30°	1625.979216	0.030 ppm
+40°	1625.979366	0.123 ppm
+50°	1625.979266	0.061 ppm
+60°	1625.978766	-0.246 ppm
+70°	1625.978866	-0.185 ppm



### 6.1.5. FREQUENCY STABILITY - VOLTAGE

#### LIMITS

FCC Part 25.202 (d)  
 +/- 10ppm (0.001%)

RSS-170 Clause 5.2  
 +/- 2.5ppm Mobile Earth Station (0.00025%)

#### TEST PROCEDURE

Peak output power was measured on each of four channels. The unit was placed into test mode and set to operate at maximum power, random modulation. The analyzer is set to max hold. Peak frequency is recorded at each voltage.

Operating voltage range is declared by the manufacturer to be between 4.8Vdc and 5.2Vdc.

#### RESULTS

Voltage (%V)	Voltage (V)	Center Frequency (Channel 1)	Error (ppm)
Center	-	1616.020833	-
96	4.8	1616.021083	0.154 ppm
98	4.9	1616.020933	0.062 ppm
100	5.0	1616.020983	0.093 ppm
102	5.1	1616.020983	0.093 ppm
104	5.2	1616.020933	0.062 ppm

Voltage (%V)	Voltage (V)	Center Frequency (Channel 75)	Error (ppm)
Center	-	1619.104167	-
96	4.8	1619.104417	0.155 ppm
98	4.9	1619.104567	0.247 ppm
100	5.0	1619.104417	0.155 ppm
102	5.1	1619.104617	0.278 ppm
104	5.2	1619.104567	0.247 ppm

Voltage (%V)	Voltage (V)	Center Frequency (Channel 150)	Error (ppm)
Center	-	1622.229167	-
96	4.8	1622.229467	0.185 ppm
98	4.9	1622.229417	0.154 ppm
100	5.0	1622.229367	0.124 ppm
102	5.1	1622.229367	0.124 ppm
104	5.2	1622.229467	0.185 ppm

Voltage (%V)	Voltage (V)	Center Frequency (Channel 240)	Error (ppm)
Center	-	1625.979167	-
96	4.8	1625.979367	0.123 ppm
98	4.9	1625.979367	0.123 ppm
100	5.0	1625.979217	0.031 ppm
102	5.1	1625.979367	0.123 ppm
104	5.2	1625.979367	0.123 ppm

## 6.1.6. DUTY CYCLE FACTOR

### LIMITS

Duty Cycle is measured to calculate average emissions. No direct limit applies.

### TEST PROCEDURE

The transmitter output is connected to a spectrum analyzer centered on the operating channel at zero span (time measurement). The resolution bandwidth is set to 1 MHz or larger. The video bandwidth is set larger than the resolution bandwidth.

A full cycle is captured and measured. Each transmission within the cycle is also captured and measured by placing markers on the start and stop edges of each transmission. From these measurements, the duty cycle factor is calculated.

### RESULTS

#### DUTY CYCLE CALCULATION

Transmission	Duration (ms)	Cycle Duration (ms)
1	8.3	90.0
Total	8.3	90.0

DUTY CYCLE IS TOTAL TRANSMISSIONS TIME WITHIN ONE CYCLE, OR 100 mS, WHICHEVER IS LESS.

DUTY CYCLE FACTOR (linear) =  $8.3\text{mS} / 90.0\text{mS} = 0.0922$  or **9.22%**

DUTY CYCLE FACTOR (dB, power) =  $10 * \text{LOG}_{10}(0.0922) = -10.35 \text{ dB}$

THE ABOVE FACTOR IS APPLIED TO PEAK MEASUREMENTS FOR RADIATED SPURIOUS EMISSIONS AND RF EXPOSURE CALCULATIONS TO CALCULATE AVERAGE VALUES.

### TRANSMIT DURATION

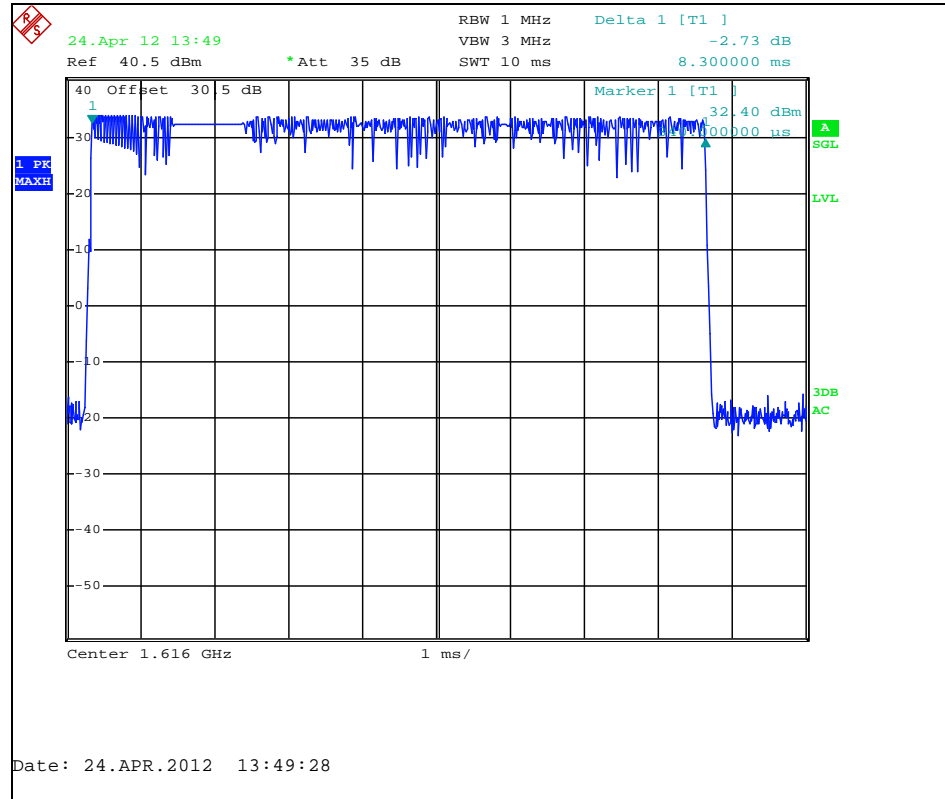

### CYCLE DURATION

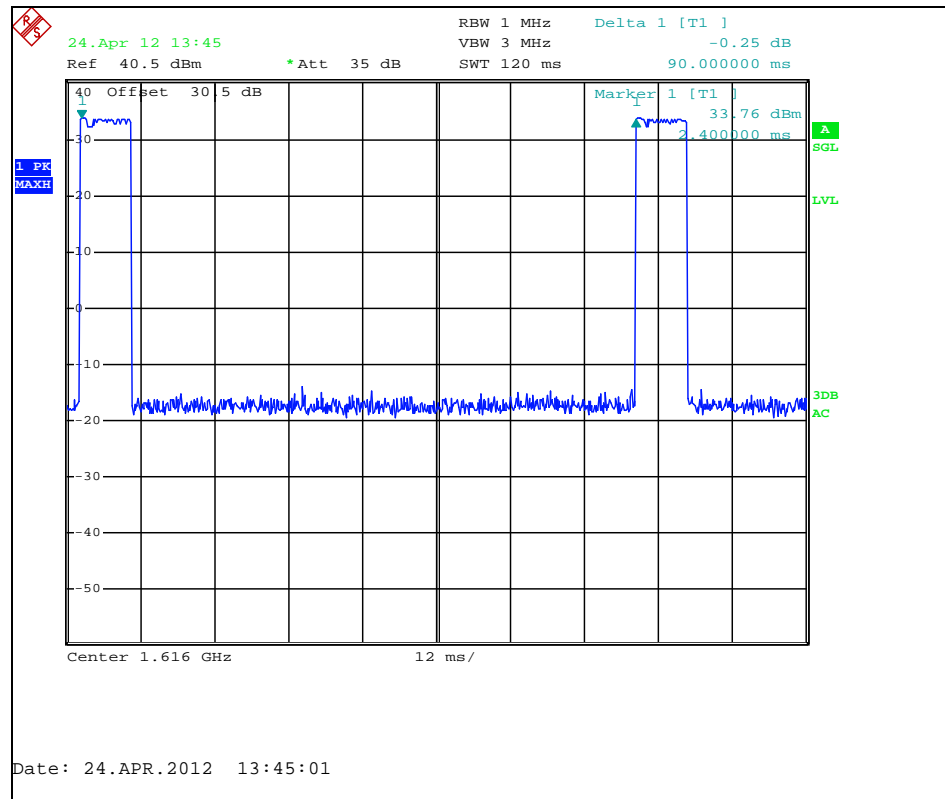

## 7. RADIATED TEST RESULTS

### 7.1. LIMITS AND PROCEDURE

#### LIMITS

FCC Part 25.202 (f) and 25.216 (Spurious), Industry Canada RSS-170 Clauses 5.4.3 and 5.4.4

Frequency (MHz)	Carrier-on		
	EIRP (dBm)	Measurement Bandwidth	Measurement method
0.15 to 30	-13	10 kHz	Peak-hold
30 to 1000	-13	100 kHz	Peak-hold
1000 to 1559	-13	100 kHz	Peak-hold
1559 to 1605	-40	100 kHz	Average
1605 to 1610	-40 to +10	100 kHz	Average
1610 to 1628.5	-	-	-
1628.5 to 16,260	-13	100 kHz	Peak-hold

Frequency (MHz)	Carrier-off		
	EIRP Density	Measurement Bandwidth	Measurement method
1559 to 1610	-80 dBW/MHz	100 kHz	Average

FCC §15.205 and §15.209 (Unintentional), Industry Canada RSS-GEN

Frequency Range (MHz)	Field Strength Limit (uV/m) at 3 m	Field Strength Limit (dBuV/m) at 3 m
30 - 88	100	40
88 - 216	150	43.5
216 - 960	200	46
Above 960	500	54

#### TEST PROCEDURE

The EUT is placed on a non-conducting table 80 cm above the ground plane. The antenna to EUT distance is 3 meters. The EUT is configured in accordance with ANSI C63.4. The EUT is set to transmit in a continuous mode.

For measurements below 1 GHz the resolution bandwidth is set to 100 kHz for peak detection measurements or 120 kHz for quasi-peak detection measurements. Peak detection is used unless otherwise noted as quasi-peak.

For measurements above 1 GHz the resolution bandwidth is set to 1 MHz for peak measurements. Bandwidth is reduced to the specified bandwidth, if applicable, for final measurements.

The spectrum from 30 MHz to 16.5 GHz is investigated with the transmitter set to the low and high channels within the 1616-1626 MHz band.

The EUT is rotated through 360 degrees to maximize emissions received. The antenna is scanned from 1 to 4 meters above the ground plane to further maximize the emission. Measurements are made with the antenna polarized in both the vertical and the horizontal positions.

## 7.2. TRANSMITTER 30-1000 MHz

### 7.2.1. RADIATED TRANSMITTER SPURIOUS EMISSIONS

#### SPURIOUS EMISSIONS, LOW CHANNEL (30 MHz – 1 GHz)

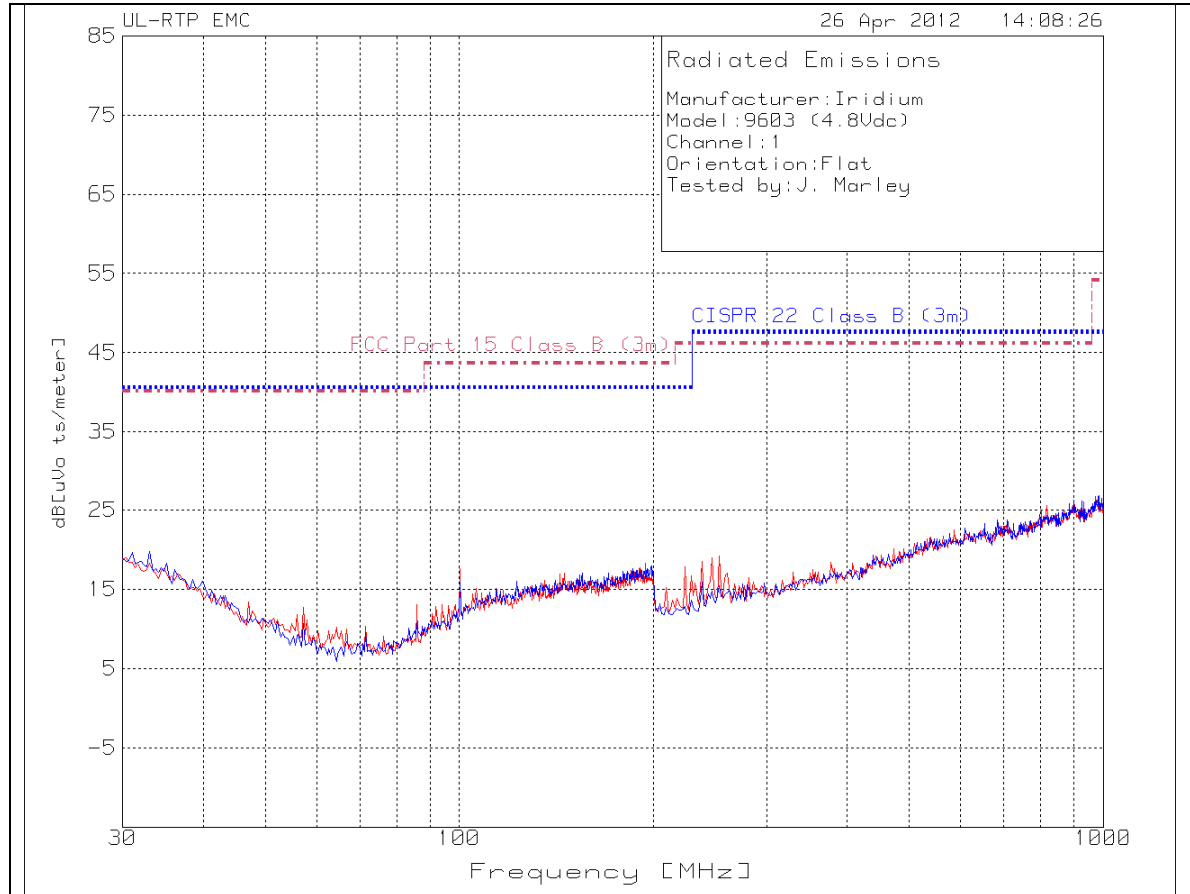

*From preliminary test, this position represents worst-case orientation from 30-1000 MHz.*

**SPURIOUS EMISSIONS, HIGH CHANNEL (30 MHz – 1 GHz)**

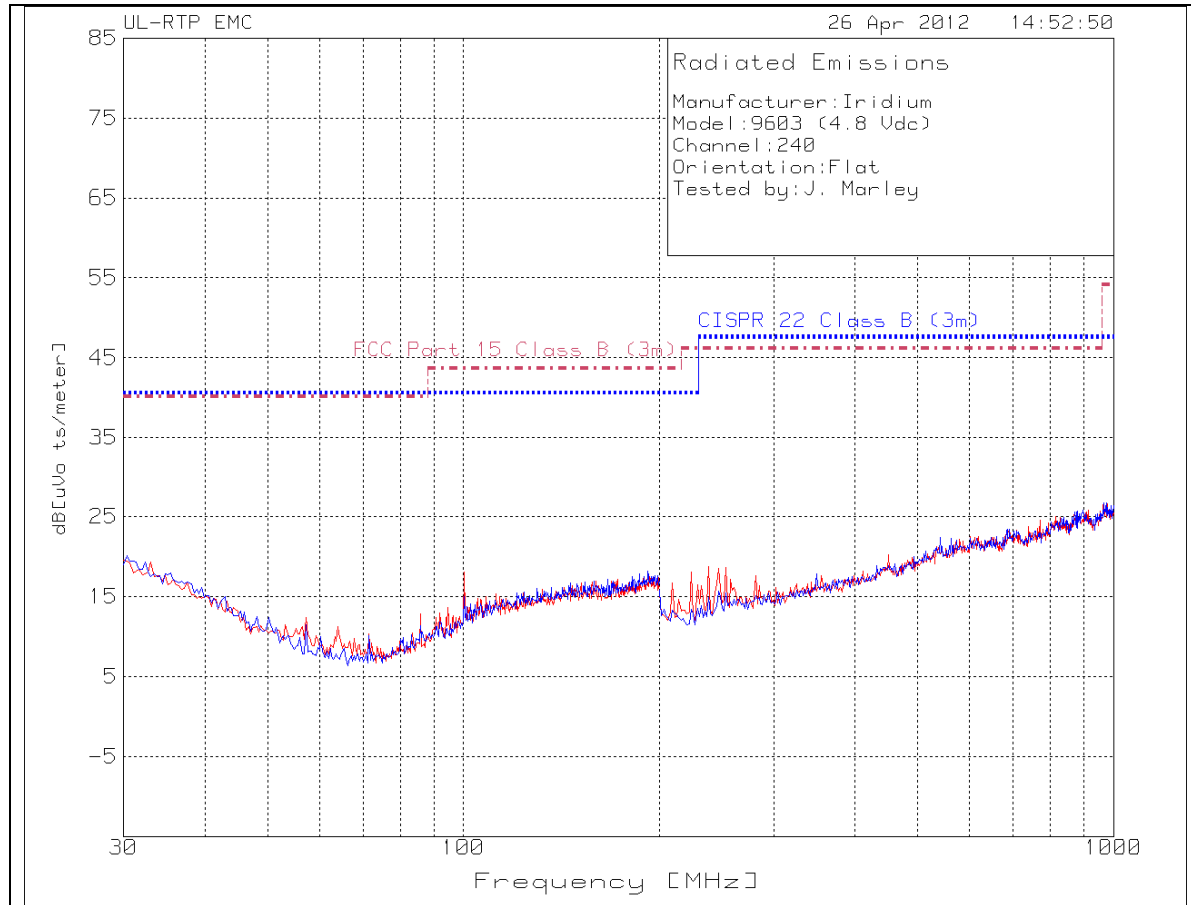

*From preliminary test, this position represents worst-case orientation from 30-1000 MHz.*

### 7.2.1. RADIATED RECEIVER SPURIOUS EMISSIONS / UNINTENTIONAL EMISSIONS

#### UNINTENTIONAL EMISSIONS, LOW CHANNEL (30 MHz – 1 GHz)

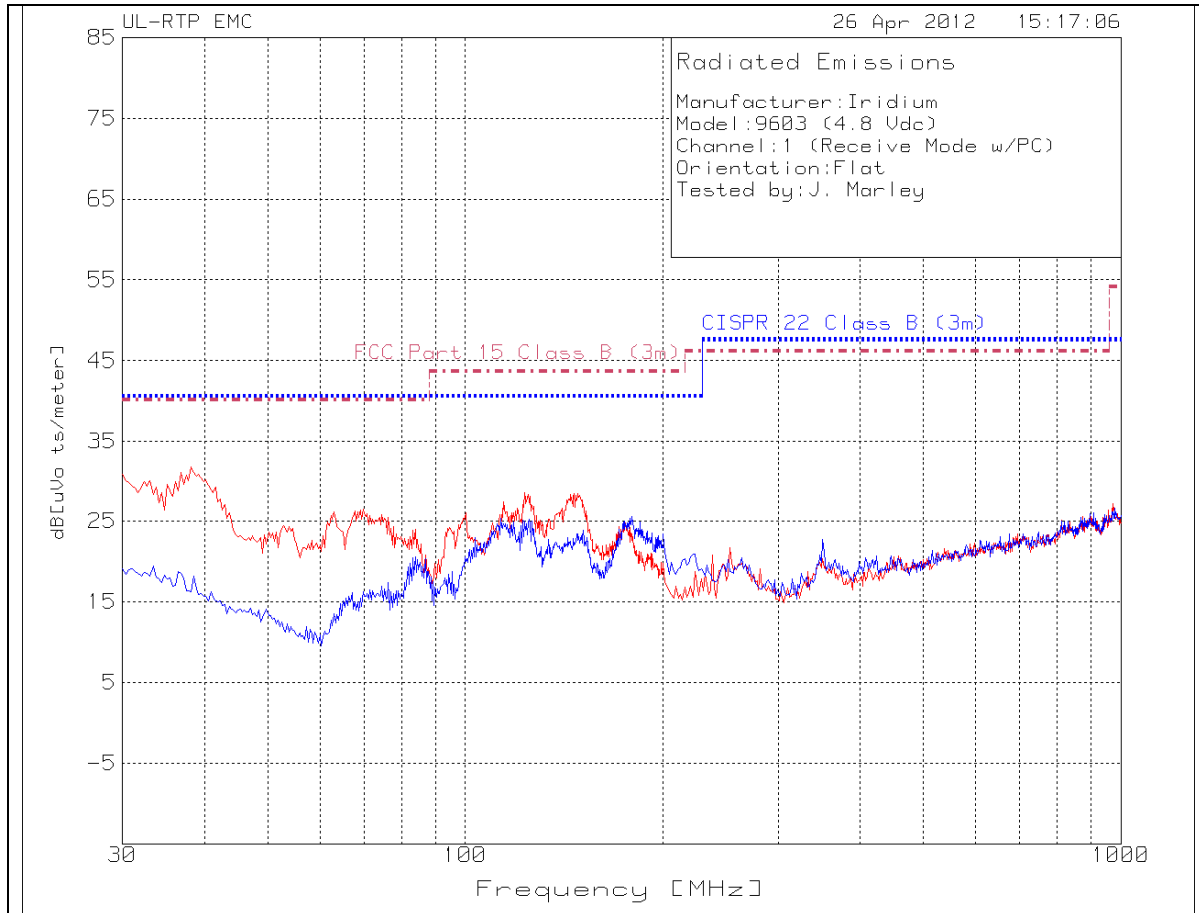

*From preliminary test, this position represents worst-case orientation from 30-1000 MHz. Includes emissions from laptop attached via serial cable.*

*Unintentional radiator measurements demonstrate compliance to FCC Part 15 Subpart B and ICES-003 radiated limits.*

**RECEIVER EMISSIONS, LOW CHANNEL (30 MHz – 1 GHz)**

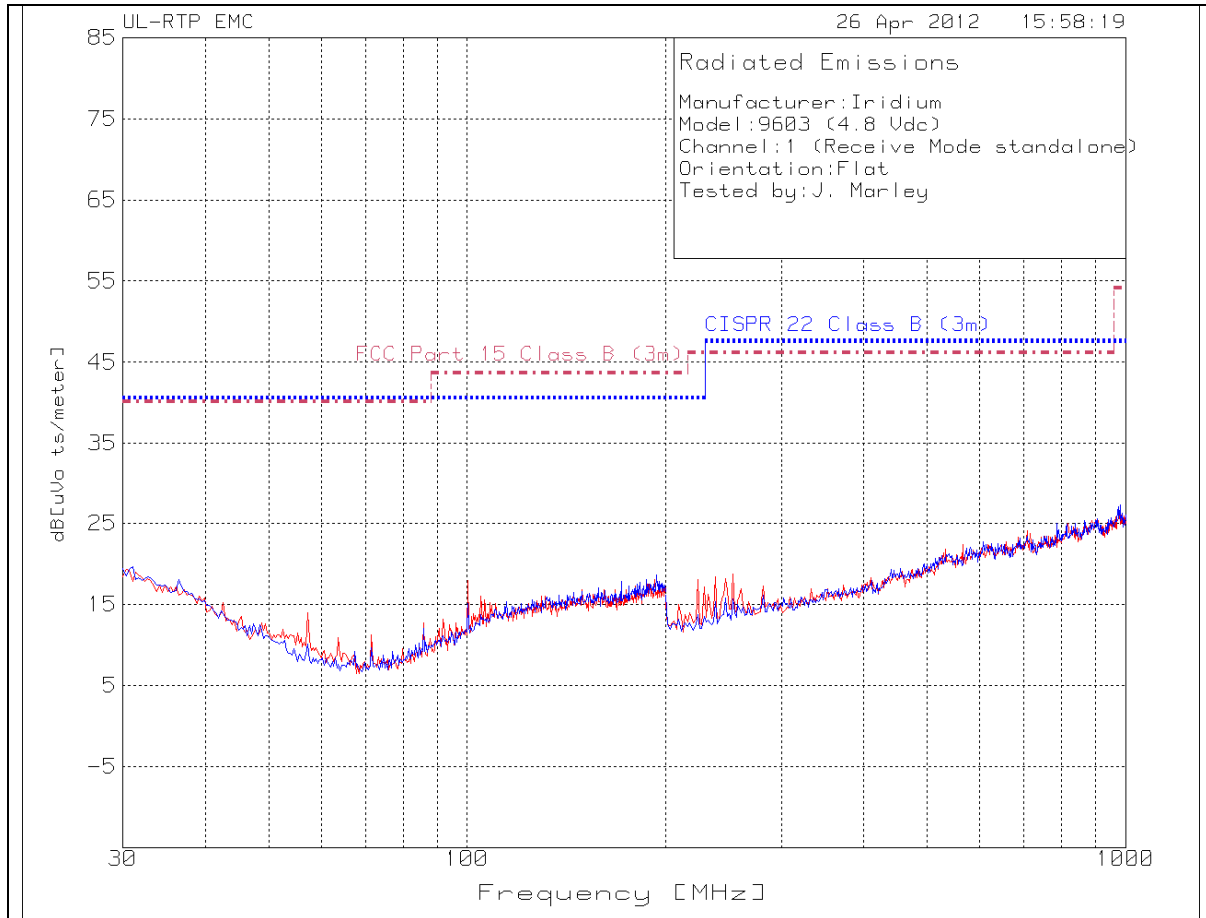

*From preliminary testing, this position represents worst-case orientation from 30-1000 MHz. No significant emission was observed in any orientation in this range.*



### 7.3. TRANSMITTER ABOVE 1 GHz

#### 7.3.1. RADIATED TRANSMITTER SPURIOUS EMISSIONS

##### LIMITS

FCC Part 15.202 (f) and 15.216

Industry Canada RSS-170 Clause 5.4.3 (Mobile Earth Station) and 5.4.4 (Receive Mode)

Frequency (MHz)	Carrier-on		
	EIRP (dBm)	Measurement Bandwidth	Measurement method
0.15 to 30	-13	10 kHz	Peak-hold
30 to 1000	-13	100 kHz	Peak-hold
1000 to 1559	-13	100 kHz	Peak-hold
1559 to 1605	-40	100 kHz	Average
1605 to 1610	-40 to +10	100 kHz	Average
1610 to 1628.5	-	-	-
1628.5 to 16260	-13	100 kHz	Peak-hold

##### TEST PROCEDURE

The spectrum from 30 MHz to 16.3 GHz is investigated with the transmitter set to the lowest and highest channels.

**RESULTS**

**SPURIOUS EMISSIONS, LOW CHANNEL (1 – 10 GHz)**

**FLAT ORIENTATION**

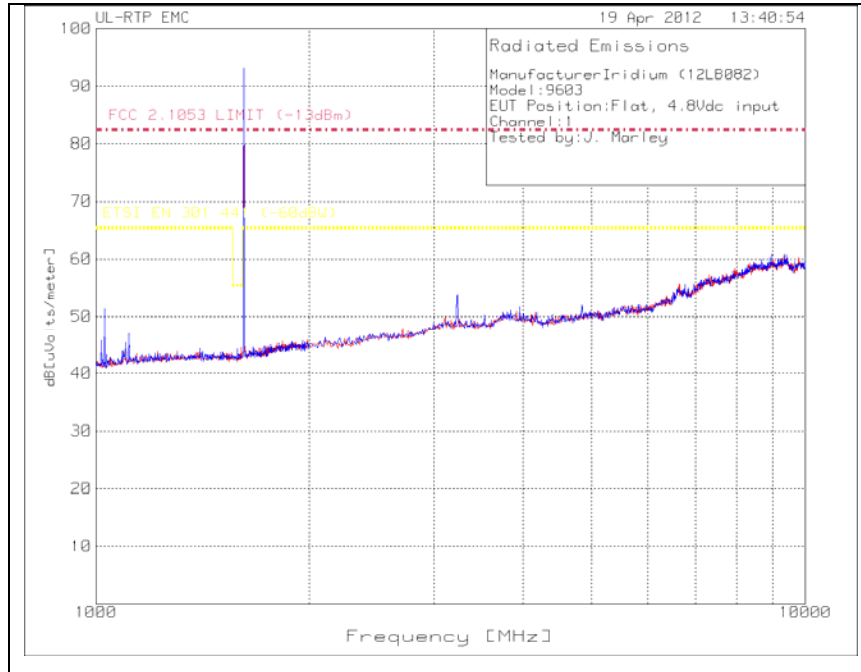

**SPURIOUS EMISSIONS, LOW CHANNEL (1 – 10 GHz)**

**SIDE ORIENTATION**

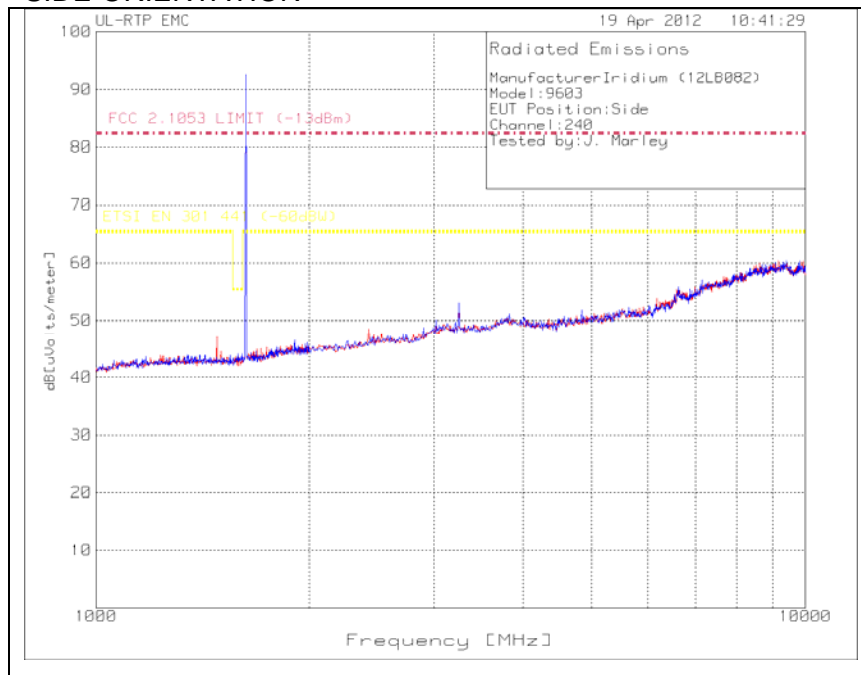

**SPURIOUS EMISSIONS, LOW CHANNEL (1 – 10 GHz)**

**UPRIGHT ORIENTATION**

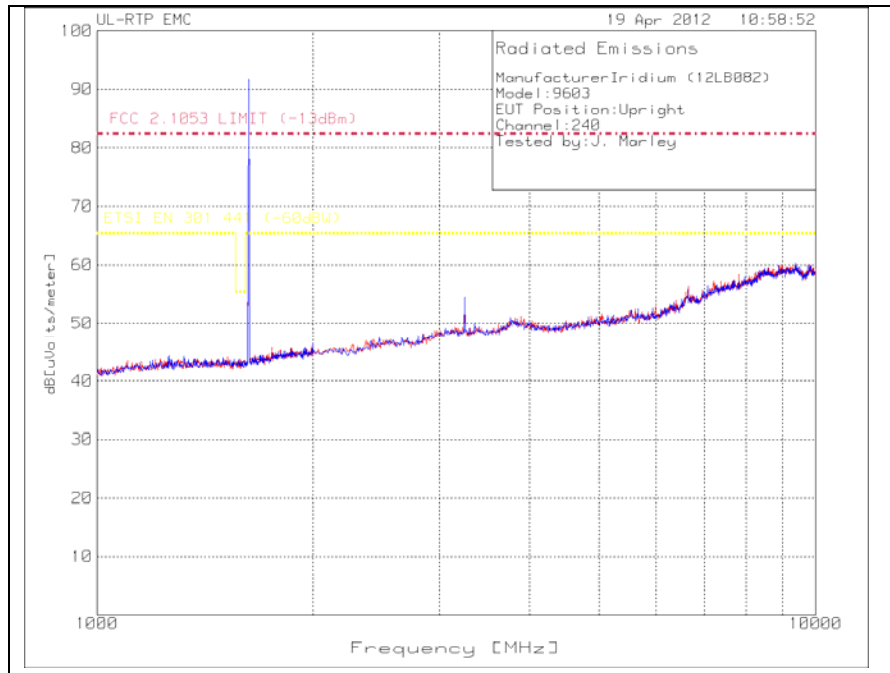

**SPURIOUS EMISSIONS, HIGH CHANNEL (1 – 10 GHz)**

**FLAT ORIENTATION**

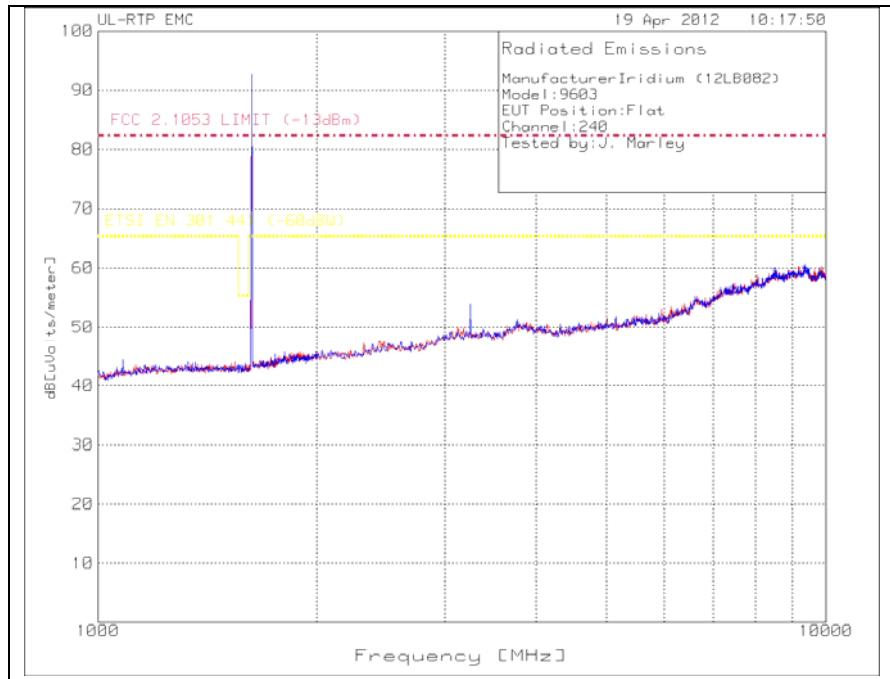

**SPURIOUS EMISSIONS, HIGH CHANNEL (1 – 10 GHz)**

**SIDE ORIENTATION**

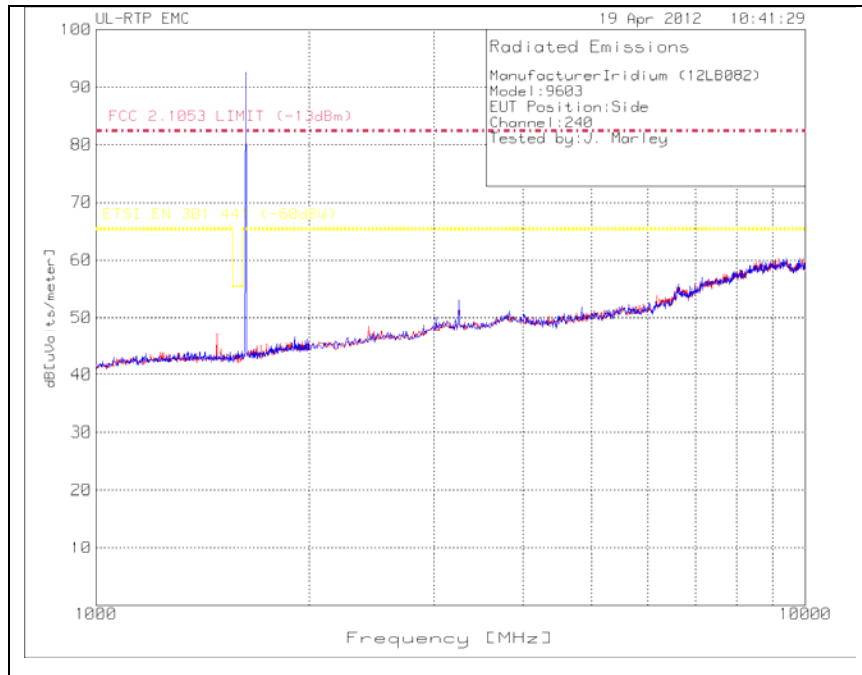

**SPURIOUS EMISSIONS, HIGH CHANNEL (1 – 10 GHz)**

**UPRIGHT ORIENTATION**

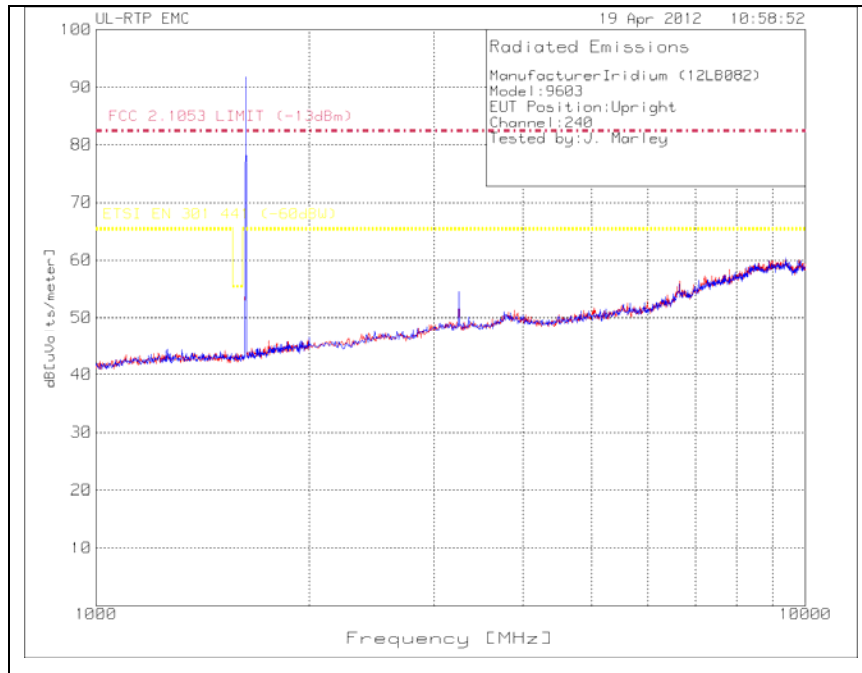

**SPURIOUS EMISSIONS, LOW CHANNEL (10 – 16.5 GHz)**

**FLAT ORIENTATION**

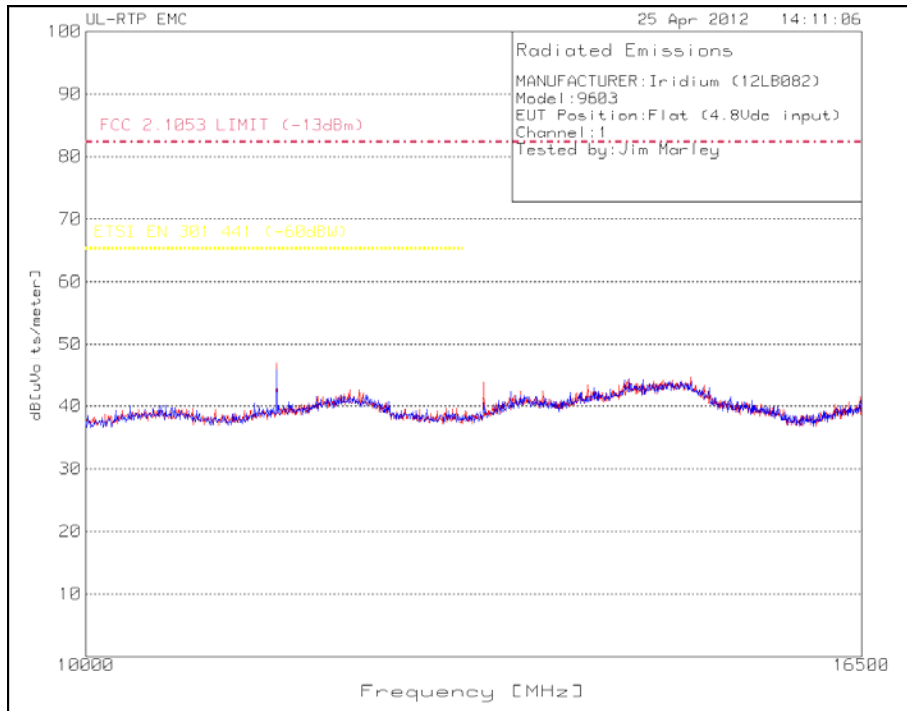

**SPURIOUS EMISSIONS, LOW CHANNEL (10 – 16.5 GHz)**

**SIDE ORIENTATION**

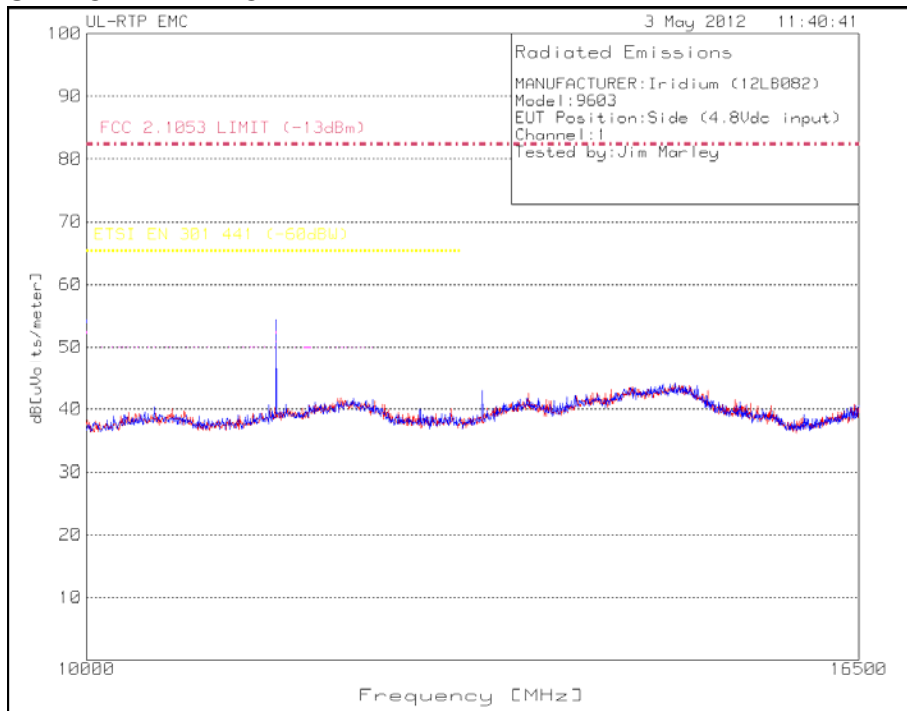

**SPURIOUS EMISSIONS, LOW CHANNEL (10 – 16.5 GHz)**

**UPRIGHT ORIENTATION**

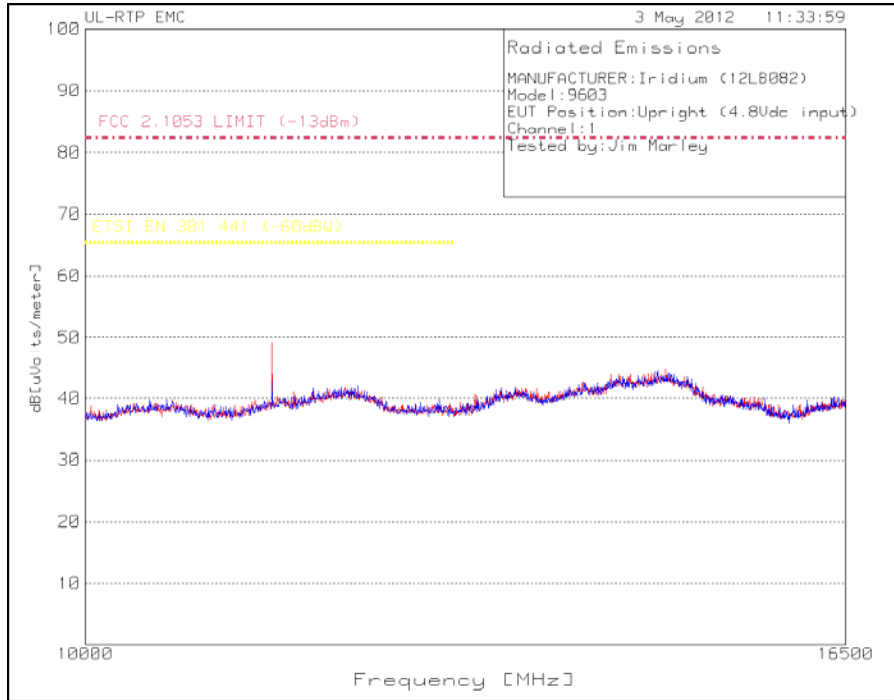

**SPURIOUS EMISSIONS, HIGH CHANNEL (10 – 16.5 GHz)**

**FLAT ORIENTATION**

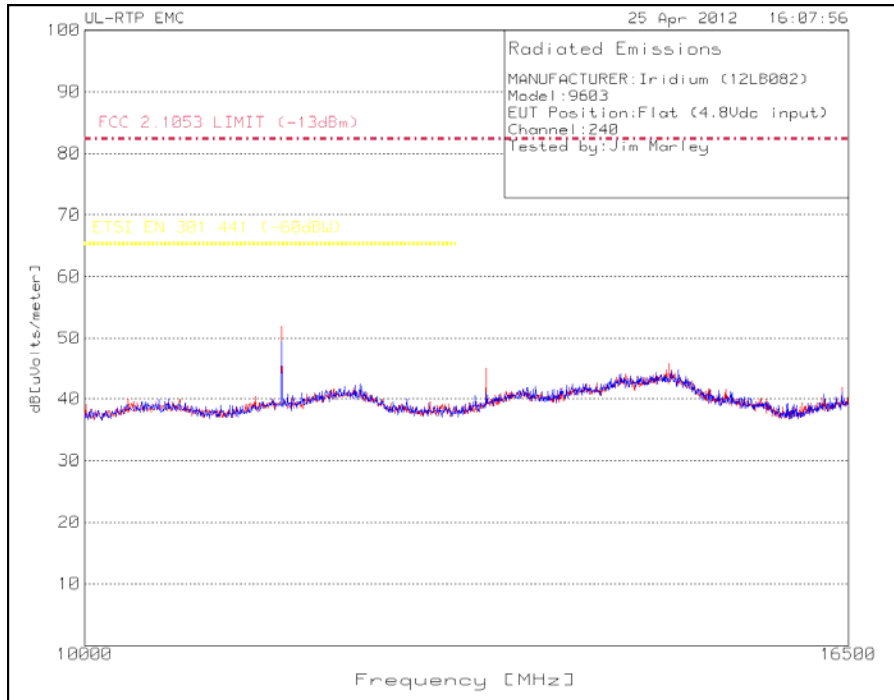

**SPURIOUS EMISSIONS, HIGH CHANNEL (10 – 16.5 GHz)**

**SIDE ORIENTATION**

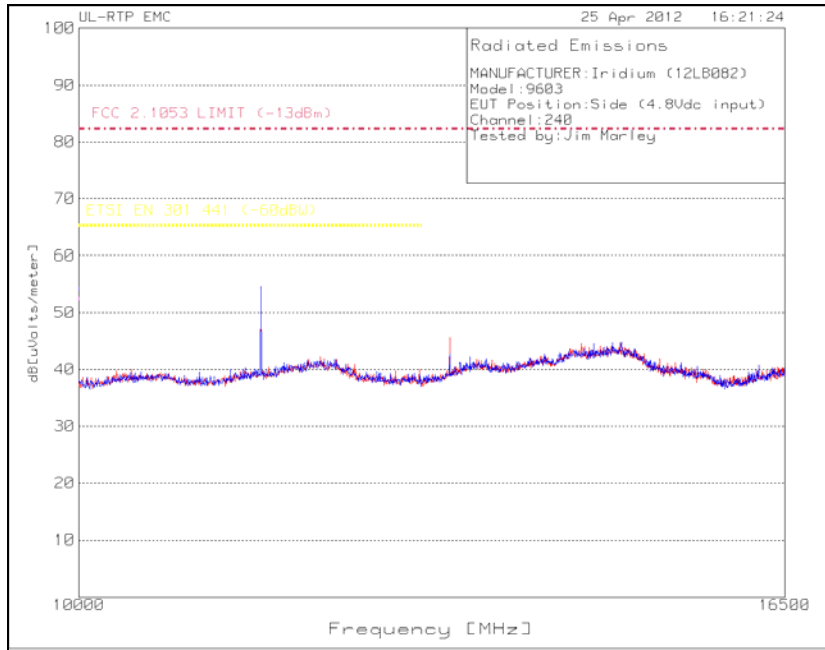

Test Frequency [MHz]	Meter Reading [dBuV]	Detector Type [Pk/QP/AV]	Antenna Factor [dB]	Amp/Cbl Factor [dB]	Field Strength [dBuV/m]	Equivalent Radiated Power [dBm]	Spurious Limit [dBm]	Anten. Height [cm]	Anten. Polarity [V/H]
11378.919	37.97	PK	39.0	-22.4	54.57	-40.63	-13	100	H
11378.919	27.62	AV	39.0	-22.4	44.22	-50.98	-13	100	H

Duty Cycle factor of -10.35dB applied to peak for average.

**SPURIOUS EMISSIONS, HIGH CHANNEL (10 – 16.5 GHz)**

**UPRIGHT ORIENTATION**

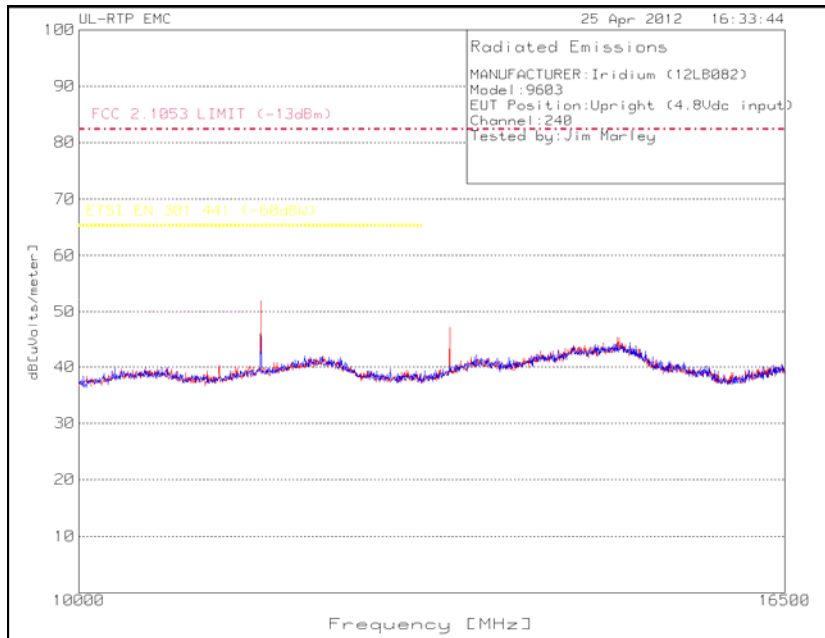

### 7.3.2. RADIATED RECEIVER SPURIOUS EMISSIONS / UNINTENTIONAL EMISSIONS

#### LIMITS

FCC §15.205 and §15.209 (Unintentional), Industry Canada RSS-GEN

Frequency Range (MHz)	Field Strength Limit (uV/m) at 3 m	Field Strength Limit (dBuV/m) at 3 m
30 - 88	100	40
88 - 216	150	43.5
216 - 960	200	46
Above 960	500	54

Industry Canada RSS-170 Clause 5.4.4 (Receive Mode)

Frequency (MHz)	Carrier-off		
	EIRP Density	Measurement Bandwidth	Measurement method
1559 to 1610	-80 dBW/MHz	100 kHz	Average

#### TEST PROCEDURE

The spectrum from 30 MHz to 16.3 GHz is investigated with the transmitter set to receive mode.

#### RECEIVER SPURIOUS EMISSIONS, HIGH CHANNEL (1 – 10 GHz)

FLAT ORIENTATION (Worst-case Orientation from Radiated Spurious Emissions is chosen)

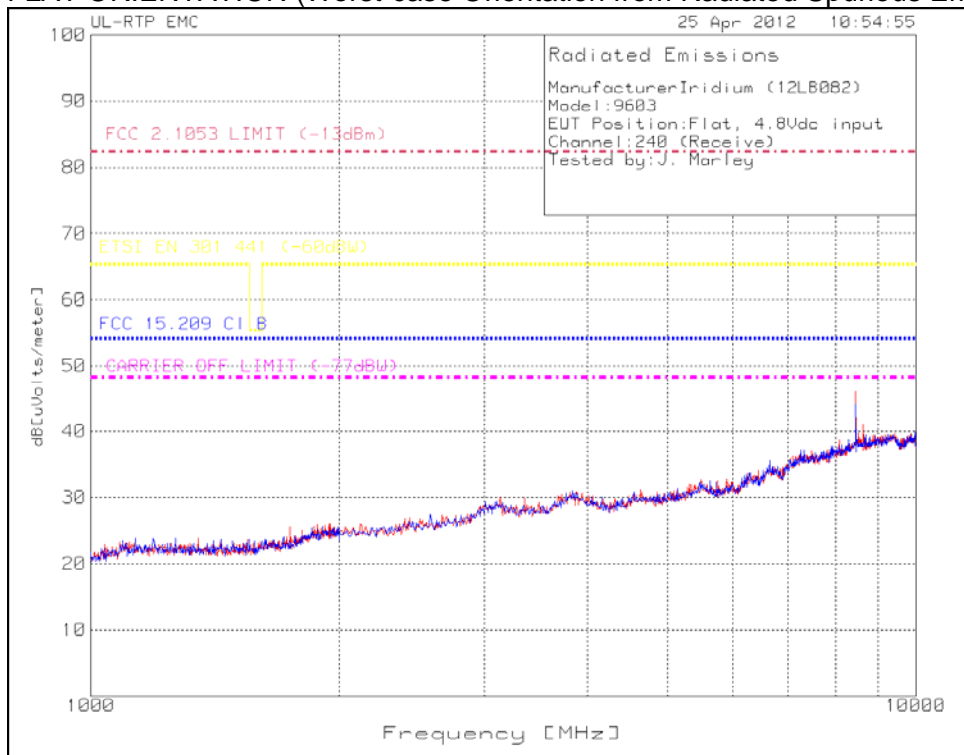



**SPURIOUS EMISSIONS, LOW CHANNEL (1 – 10 GHz)**

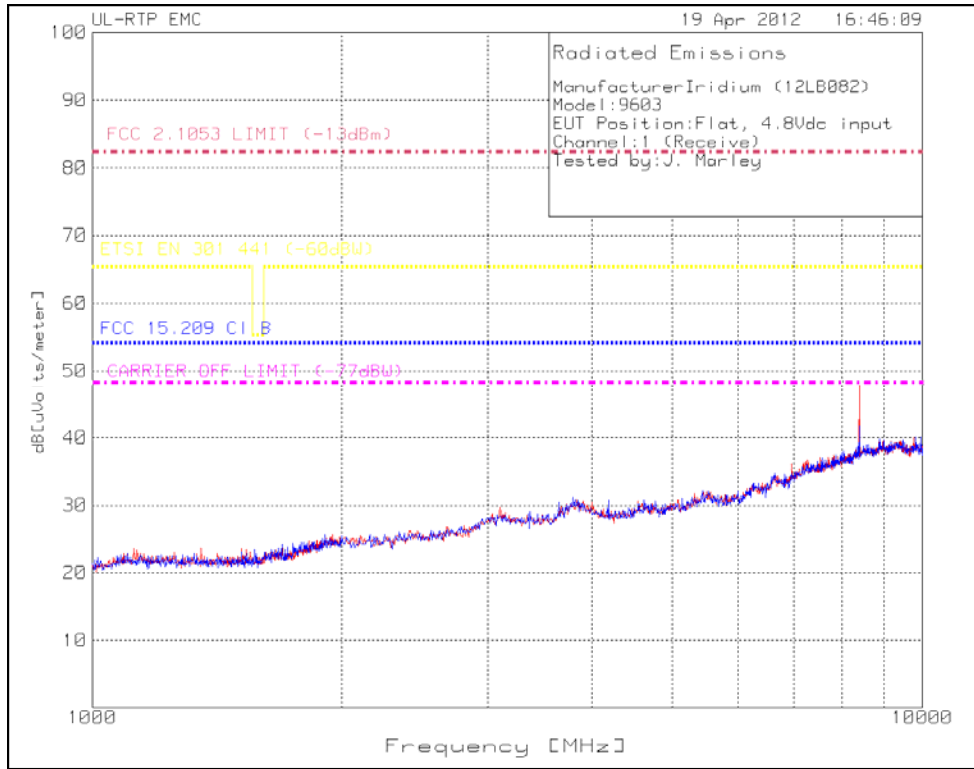

Test Frequency [MHz]	Meter Reading [dBuV]	Detector Type [Pk/QP/Av]	Antenna Factor [dB]	Amp/Cbl Factor [dB]	Field Strength [dBuV/m]	15.209 Limit [dBuV/m]	Anten. Height [cm]	Anten. Polarity [V/H]
8398.398	34.59	Pk	37.2	-23.6	48.19	54.0	154	Vert

**SPURIOUS EMISSIONS, LOW CHANNEL (10 – 16.5 GHz)**

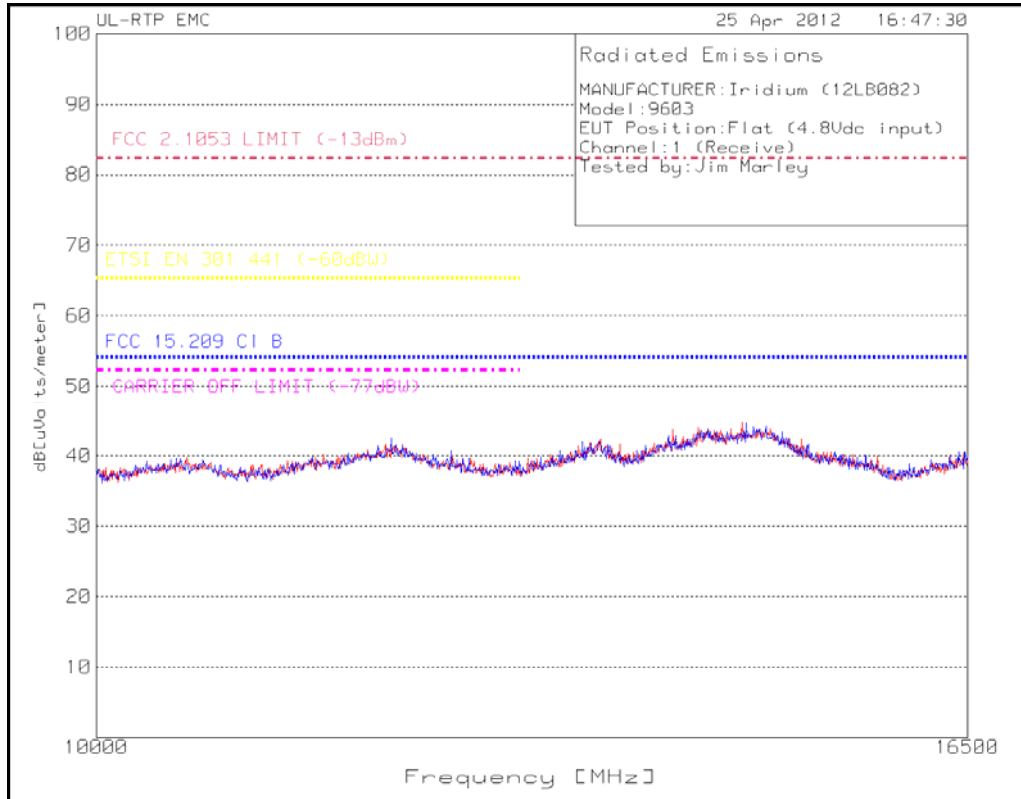

**SPURIOUS EMISSIONS, HIGH CHANNEL (10 – 16.5 GHz)**

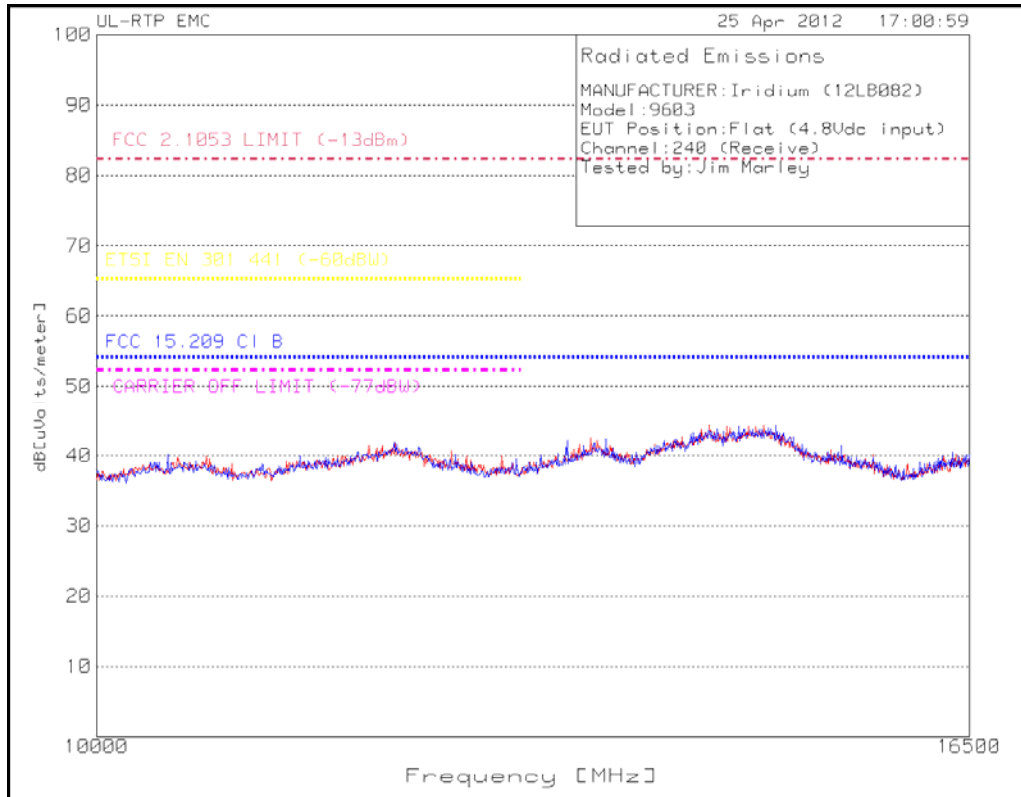

## 8. AC POWER LINE CONDUCTED EMISSIONS

### LIMITS

FCC §15.207 (a), Industry Canada RSS-GEN

Frequency of Emissions (MHz)	Conducted Limit (dBuV)	
	Quasi-peak	Average
0.15 – 0.5	60 to 56*	56 to 46*
0.5 – 5	56	46
5 – 30	60	50

\*Decreases with the logarithm of the frequency.

### TEST PROCEDURE

The EUT is connected to AC mains through a Line Impedance Stabilization Network (LISN). The EUT is placed on a non-conducting table 40 cm from the vertical ground plane and 80 cm above the horizontal ground plane. The EUT is configured in accordance with ANSI C63.4.

The receiver is set to a resolution bandwidth of 9 kHz. Peak detection is displayed on the graph shown. Quasi-peak and average detector measurement are shown in the table provided.

Line conducted data is recorded for both NEUTRAL and HOT lines.

### Comment

A typical AC adapter is used. An AC-to-DC adapter is not provided to the integrator. Although not required, emissions on DC leads are also performed.

*Measurements also demonstrate compliance to FCC Part 15 Subpart B and ICES-003 conducted limits.*

**RESULTS**

**AC CONDUCTED EMISSIONS – LINE CONDUCTOR**

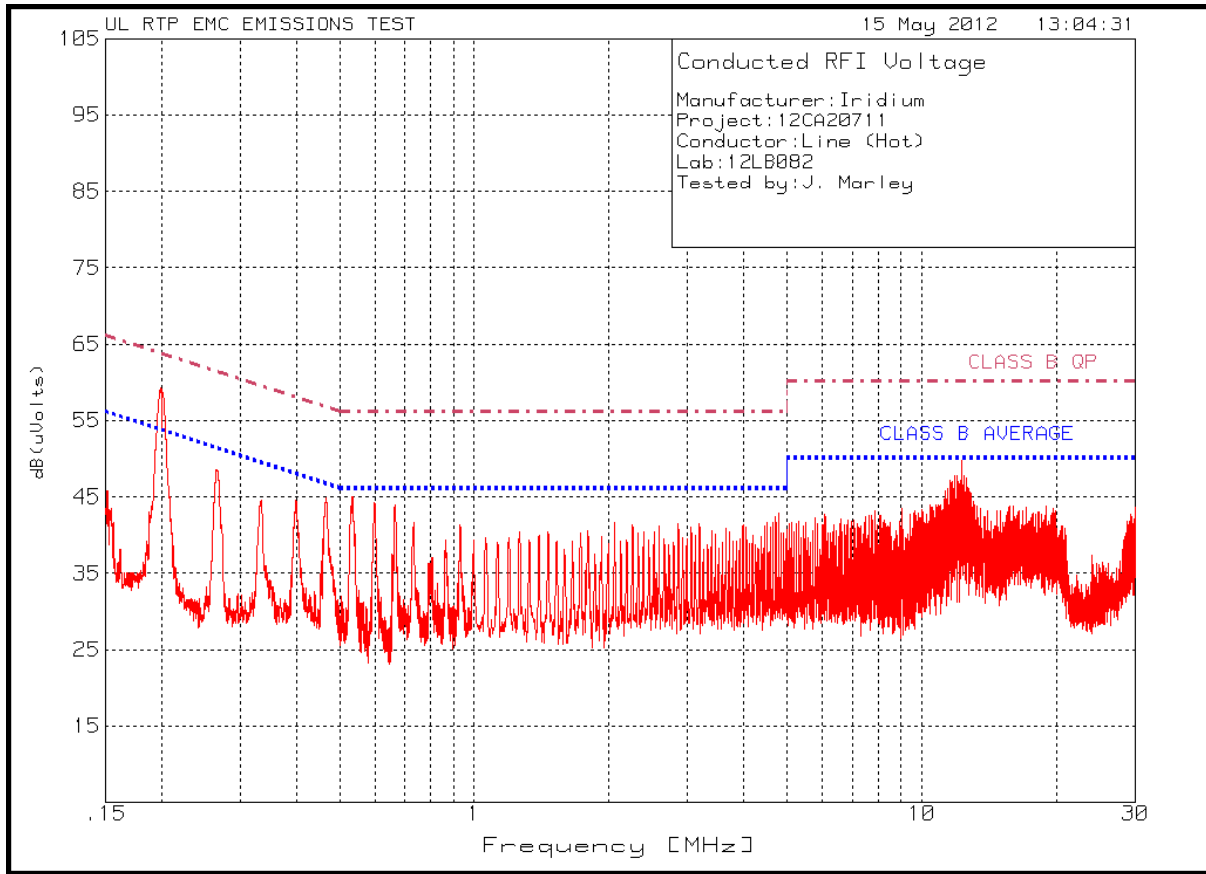

Test Frequency [MHz]	Meter Reading [dBuV]	Detector Type [Pk/QP/Av]	LISN Factor [dB]	Atten. Factor [dB]	Noise Voltage [dBuV]	Cl B Limit Quasi-Pk [dBuV]	Cl B Margin Quasi-Pk [dB]	Cl B Limit Average [dBuV]	Cl B Margin Average [dB]
.19944	44.39	QP	.1	10.9	55.39	63.63	-8.24	-	-
.265935	33.78	QP	.1	10.9	44.78	61.24	-16.46	-	-
.464938	33.37	QP	0	10.9	44.27	56.6	-12.33	-	-
.531508	32.69	QP	0	10.9	43.59	56	-12.41	-	-
.596545	30.7	QP	0	10.9	41.6	56	-14.4	-	-
.663943	29.96	QP	0	10.9	40.86	56	-15.14	-	-
12.30615	20.46	QP	.1	11.5	32.06	60	-27.94	-	-
.19944	25.67	CAV	.1	10.9	36.67	-	-	53.63	-16.96
.265935	22.03	CAV	.1	10.9	33.03	-	-	51.24	-18.21
.464938	26.53	CAV	0	10.9	37.43	-	-	46.6	-9.17
.531508	27.09	CAV	0	10.9	37.99	-	-	46	-8.01
.596545	24.22	CAV	0	10.9	35.12	-	-	46	-10.88
.663943	21.03	CAV	0	10.9	31.93	-	-	46	-14.07
12.30615	14.01	CAV	.1	11.5	25.61	-	-	50	-24.39

QP - Quasi-Peak detector

CAV - CISPR Average detector

AC CONDUCTED EMISSIONS – NEUTRAL CONDUCTOR

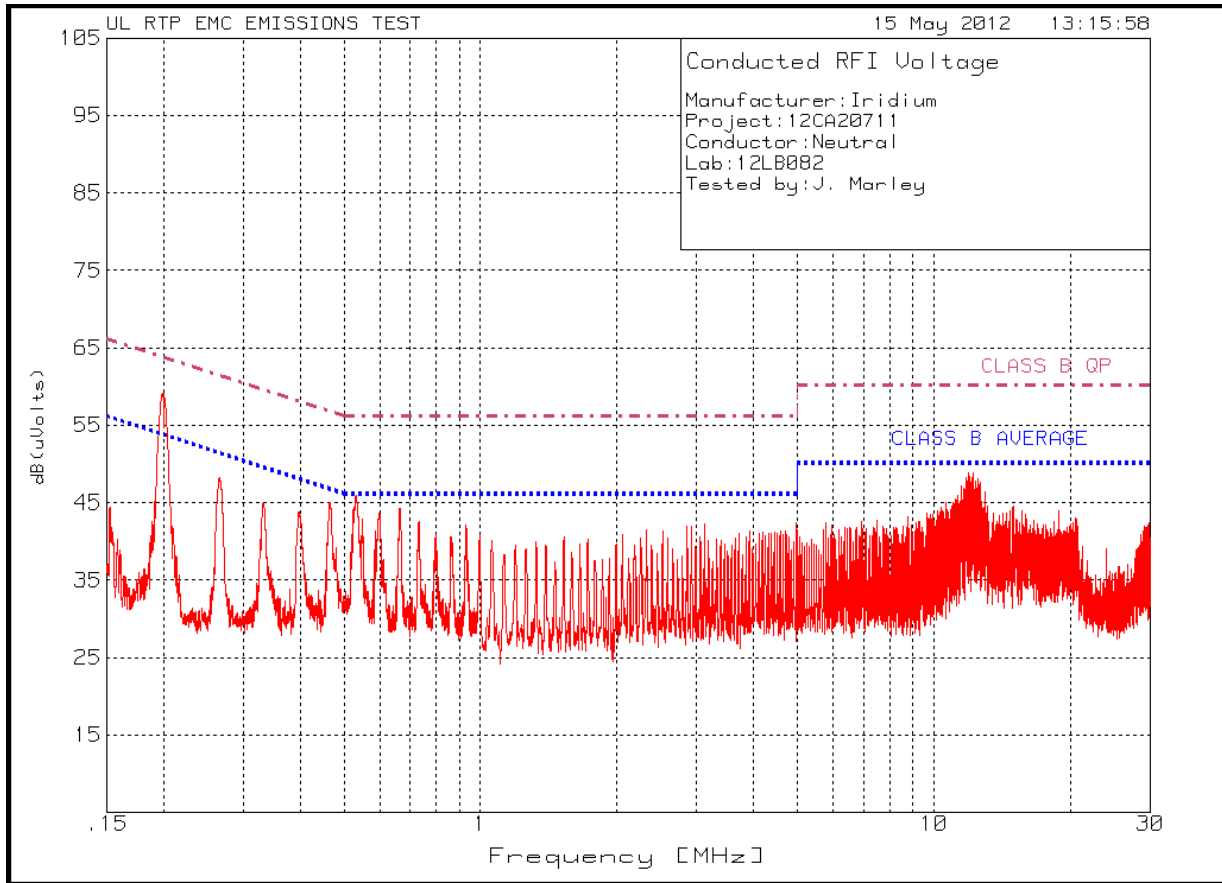

Test Frequency [MHz]	Meter Reading [dBuV]	Detector Type [PK/QP/Av]	LISN Factor [dB]	Atten. Factor [dB]	Noise Voltage [dBuV]	Cl B Limit Quasi-Pk [dBuV]	Cl B Margin Quasi-Pk [dB]	Cl B Limit Average [dBuV]	Cl B Margin Average [dB]
.199088	43.8	QP	.1	10.9	54.8	63.65	-8.85	53.65	1.15
.46353	32.84	QP	0	10.9	43.74	56.63	-12.89	46.63	-2.89
.529778	31.93	QP	0	10.9	42.83	56	-13.17	46	-3.17
.596568	30.77	QP	0	10.9	41.67	56	-14.33	46	-4.33
.664315	29.63	QP	0	10.9	40.53	56	-15.47	46	-5.47
11.95405	31.7	QP	.1	11.5	43.3	60	-16.7	50	-6.7
12.2358	25.7	QP	.1	11.5	37.3	60	-22.7	50	-12.7
.199088	28.74	CAV	.1	10.9	39.74	63.65	-23.91	53.65	-13.91
.46353	26.05	CAV	0	10.9	36.95	56.63	-19.68	46.63	-9.68
.529778	26.25	CAV	0	10.9	37.15	56	-18.85	46	-8.85
.596568	24.08	CAV	0	10.9	34.98	56	-21.02	46	-11.02
.664315	21.16	CAV	0	10.9	32.06	56	-23.94	46	-13.94
11.95405	17.26	CAV	.1	11.5	28.86	60	-31.14	50	-21.14
12.2358	19.73	CAV	.1	11.5	31.33	60	-28.67	50	-18.67

QP - Quasi-Peak detector  
 CAV - CISPR Average detector

**RESULTS**

**CONDUCTED EMISSIONS – +Vcc**

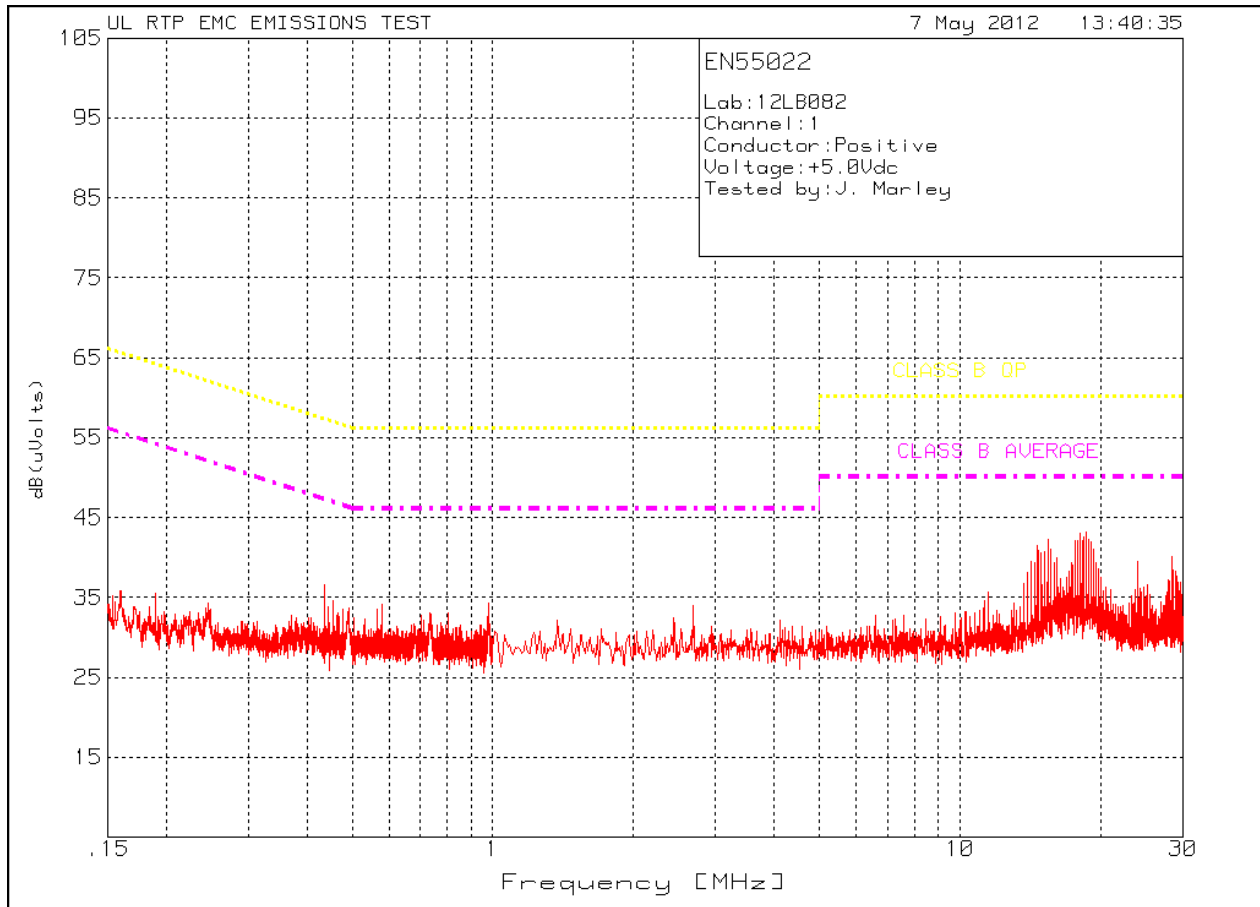

Test Frequency [MHz]	Meter Reading [dBuV]	Detector Type [Pk/QP/Av]	LISN Factor [dB]	Atten. Factor [dB]	Noise Voltage [dBuV]	Cl B Limit Quasi-Pk [dBuV]	Cl B Margin Quasi-Pk [dB]	Cl B Limit Average [dBuV]	Cl B Margin Average [dB]
0.435413	25.06	QP	0	10.9	35.96	56.9	-20.94	-	-
0.979355	14.31	QP	0	11.0	25.31	56	-30.69	-	-
15.42125	27.70	QP	.1	11.6	39.4	60	-20.6	-	-
18.603725	28.87	QP	.1	11.7	40.67	60	-19.33	-	-
23.99555	25.41	QP	.2	11.8	37.41	60	-22.59	-	-
28.397225	22.98	QP	.2	11.8	34.98	60	-25.02	-	-
0.435413	9.34	Av	0	10.9	20.24	-	-	46.9	-26.56
0.979355	14.43	Av	0	11.0	25.43	-	-	46	-20.57
15.42125	25.12	Av	.1	11.6	36.82	-	-	50	-13.18
18.603725	25.92	Av	.1	11.7	37.72	-	-	50	-12.28
23.99555	21.69	Av	.2	11.8	33.69	-	-	50	-16.31
28.397225	18.63	Av	.2	11.8	30.63	-	-	50	-19.37

CONDUCTED EMISSIONS – +Vcc RETURN

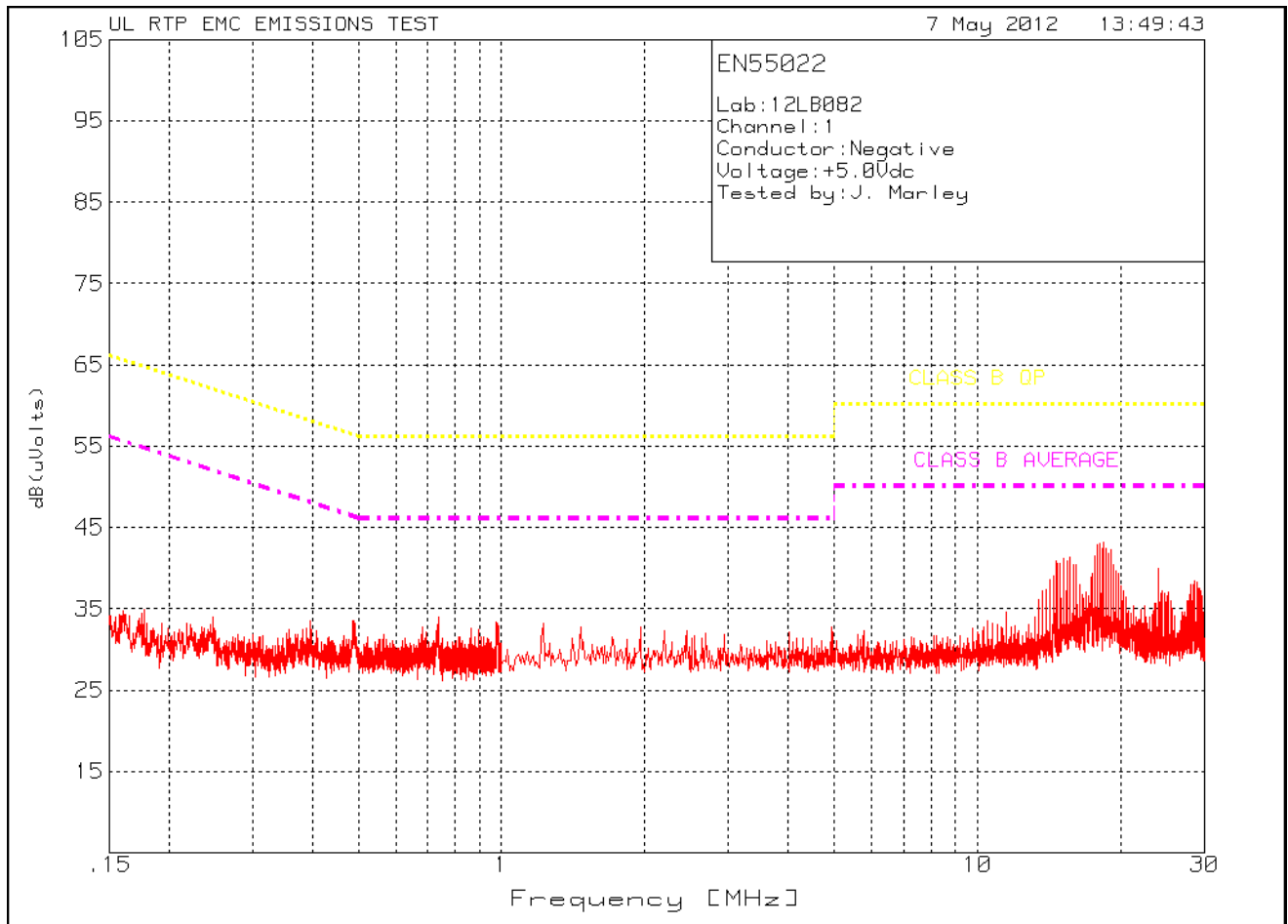

Test Frequency [MHz]	Meter Reading [dBuV]	Detector Type [Pk/QP/Av]	LISN Factor [dB]	Atten. Factor [dB]	Noise Voltage [dBuV]	Cl B Limit Quasi-Pk [dBuV]	Cl B Margin Quasi-Pk [dB]	Cl B Limit Average [dBuV]	Cl B Margin Average [dB]
0.734595	14.88	QP	0	10.9	25.78	56	-30.22	-	-
14.6882	26.8	QP	.1	11.6	38.5	60	-21.5	-	-
15.6677	27.29	QP	.1	11.6	38.99	60	-21.01	-	-
18.114975	29.35	QP	.1	11.7	41.15	60	-18.85	-	-
18.361125	29.76	QP	.1	11.7	41.56	60	-18.44	-	-
23.995875	25.25	QP	.2	11.8	37.25	60	-22.75	-	-
0.734595	14.42	Av	0	10.9	25.32	-	-	46	-30.68
14.6882	24.45	Av	.1	11.6	36.15	-	-	50	-13.85
15.6677	24.58	Av	.1	11.6	36.28	-	-	50	-13.72
18.114975	26.44	Av	.1	11.7	38.24	-	-	50	-11.76
18.361125	26.59	Av	.1	11.7	38.39	-	-	50	-11.61
23.995875	21.6	Av	.2	11.8	33.6	-	-	50	-16.4

## 9. MAXIMUM PERMISSIBLE EXPOSURE

### FCC RULES

§1.1310 The criteria listed in Table 1 shall be used to evaluate the environmental impact of human exposure to radio-frequency (RF) radiation as specified in §1.1307(b), except in the case of portable devices which shall be evaluated according to the provisions of §2.1093 of this chapter.

1.1310 – Table 1(b) LIMITS for GENERAL POPULATION/UNCONTROLLED EXPOSURE

Frequency Range (MHz)	Electric Field (V/m rms)	Magnetic Field (A/m rms)	Power Density (mW/cm <sup>2</sup> )	Averaging Time (minutes)
0.3-1.34	614	1.63	*(100)	
1.34-30	824/f	2.19/f	*(180/f <sup>2</sup> )	30
30-300	27.5	0.073	0.2	30
300-1500			f/1500	30
1500-100,000	-	-	1.0	30

### INDUSTRY CANADA RULES

RSS-102 Issue 4 (March 2010) General Population/Uncontrolled Exposure

Frequency Range (MHz)	Electric Field (V/m rms)	Magnetic Field (A/m rms)	Power Density (W/m <sup>2</sup> )	Averaging Time (minutes)
0.003-1	280	2.19	-	6
1-10	280/f	2.19/f	-	6
10-30	28	2.19/f	-	6
30-300	28	0.073	2*	6
300-1500	1.585 f <sup>0.5</sup>	0.0042 f <sup>0.5</sup>	f/150	6
1500-15000	61.4	0.163	10	6
15000-150000	61.4	0.163	10	616000/f 1.2
150000-300000	0.158 f <sup>0.5</sup>	4.21 x 10 <sup>-4</sup> f <sup>0.5</sup>	6.67 x 10 <sup>-5</sup> f	616000/f 1.2

Power Density Limit for 1616-1626 MHz frequency range is 100mW/cm<sup>2</sup> (10W/m<sup>2</sup>).



## **EQUATIONS**

Power density is given by:

$$S = \text{EIRP} / (4 * \text{Pi} * D^2)$$

where

S = Power density in W/m<sup>2</sup>  
EIRP = Equivalent Isotropic Radiated Power in W  
D = Separation distance in m

Power density in units of W/m<sup>2</sup> is converted to units of mW/cm<sup>2</sup> by dividing by 10.

Distance is given by:

$$D = \text{SQRT} (\text{EIRP} / (4 * \text{Pi} * S))$$

where

D = Separation distance in m  
EIRP = Equivalent Isotropic Radiated Power in W  
S = Power density in W/m<sup>2</sup>

For multiple colocated transmitters operating simultaneously in frequency bands where the limit is identical, the total power density is calculated using the total EIRP obtained by summing the Power \* Gain product (in linear units) of each transmitter.

$$\text{Total EIRP} = (P1 * G1) + (P2 * G2) + \dots + (Pn * Gn)$$

where

Px = Power of transmitter x  
Gx = Numeric gain of antenna x

In the table(s) below, Power and Gain are entered in units of dBm and dBi respectively and conversions to linear forms are used for the calculations.

## **LIMITS**

From FCC §1.1310 Table 1 (B), the maximum value of S = 1.0 mW/cm<sup>2</sup>

**RESULTS – 20 cm spacing**

**General Public**

Operating Frequency	1616	MHz		
Output Power (Max Avg)	1.383	Watts		
Antenna Gain	3.0	dB	or (linear)	1.995262 (unitless)
Separation Distance	0.20	m	-or-	7.874 inches

Peak Power Density 2.760 W/m<sup>2</sup> - or - 0.2760 mW/cm<sup>2</sup>

Exposure % (over 6 min timespan for uncontrolled)	100%
--	------

Transmit Duty Cycle (Peak-to-Average Ratio)	9.222%
--	--------

Average Power Density **0.506** W/m<sup>2</sup> - or - **0.0506** mW/cm<sup>2</sup>

Limit for **Uncontrolled**

Exposure at Operating Frequency **10.0** W/m<sup>2</sup> - or - **1.00** mW/cm<sup>2</sup>

SETUP PHOTOS

**RADIATED RF MEASUREMENT SETUP**

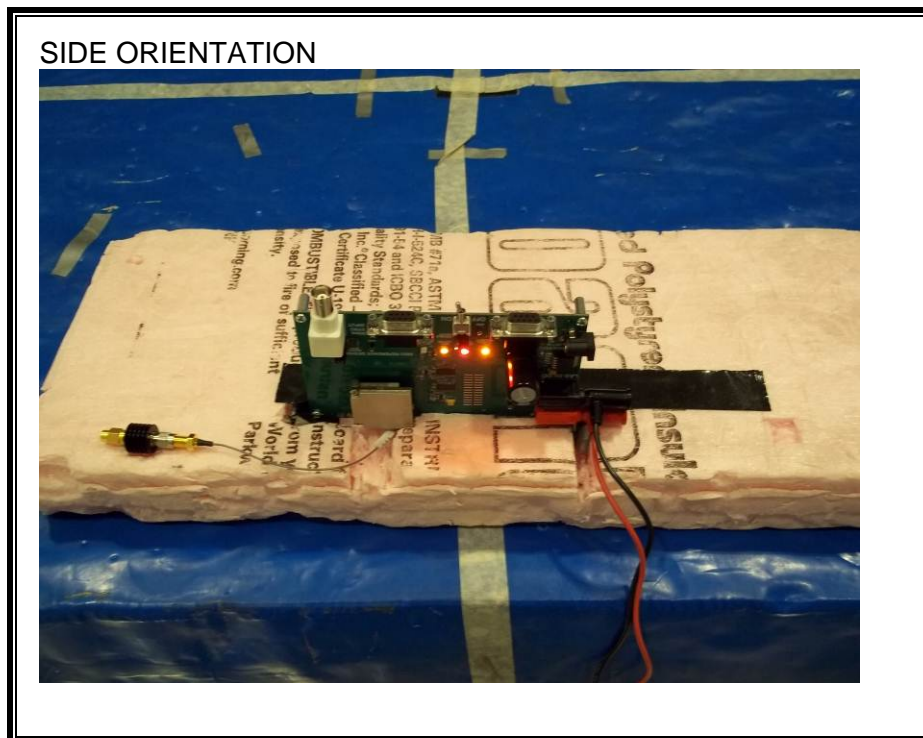
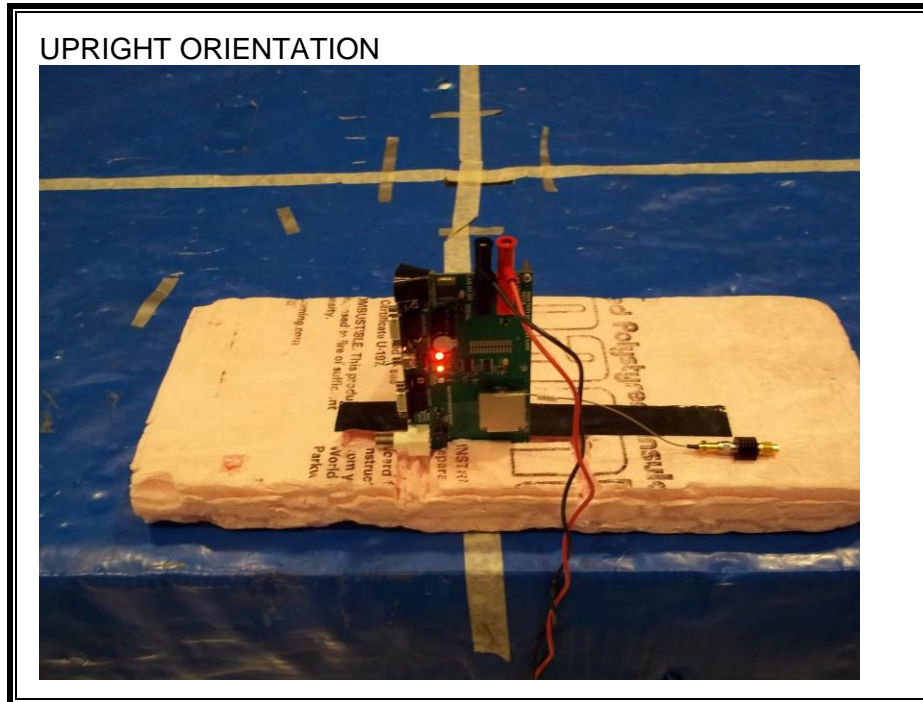

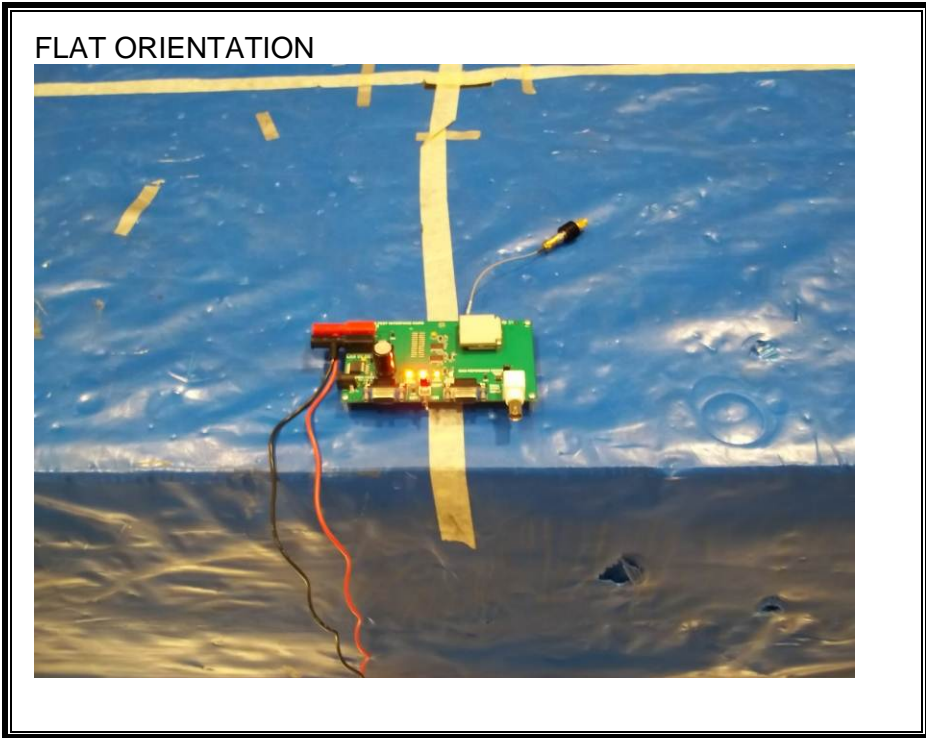

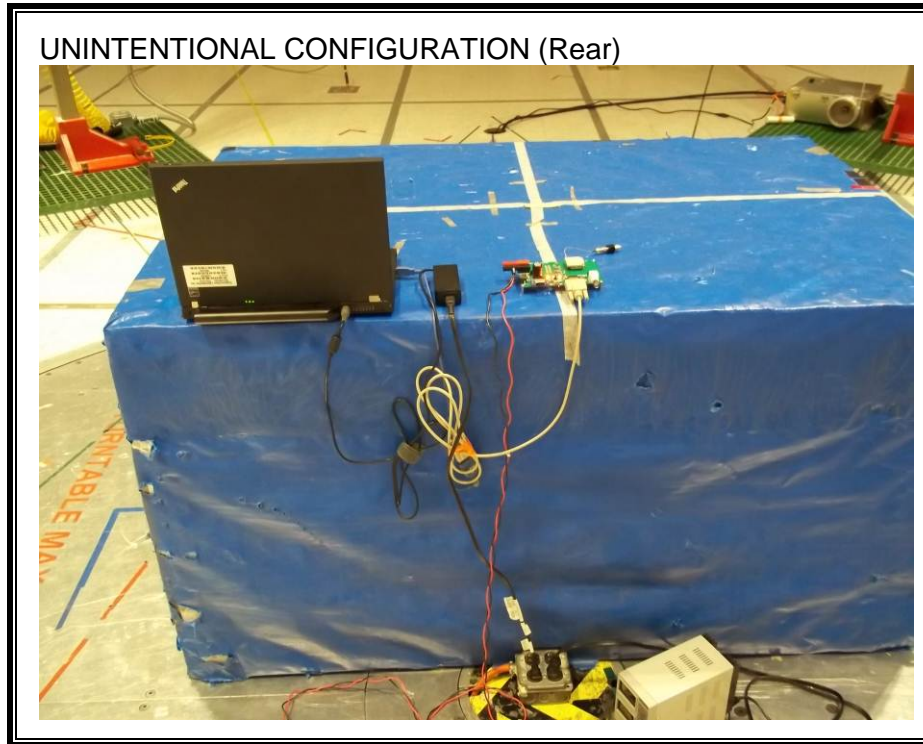

**CONDUCTED (ANTENNA PORT) RF MEASUREMENT SETUP**

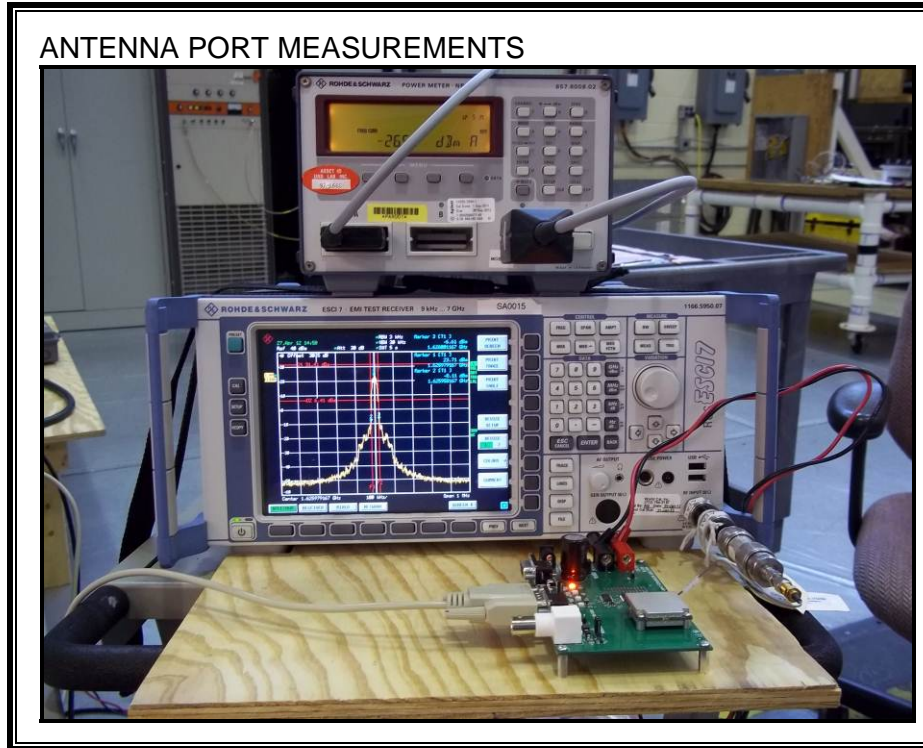

**POWERLINE CONDUCTED EMISSIONS MEASUREMENT SETUP**

**AC LEADS**

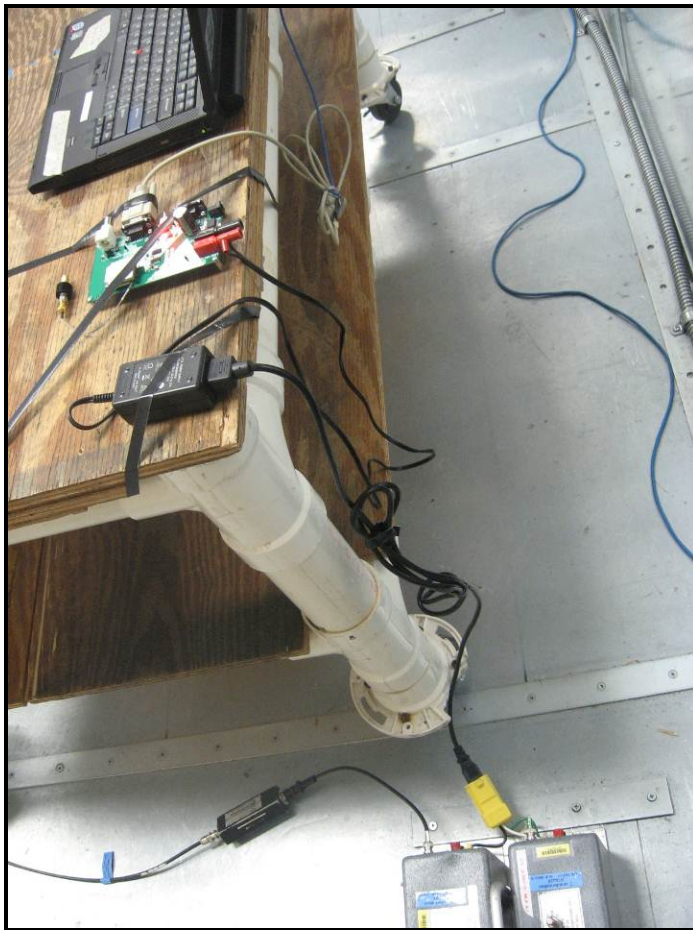
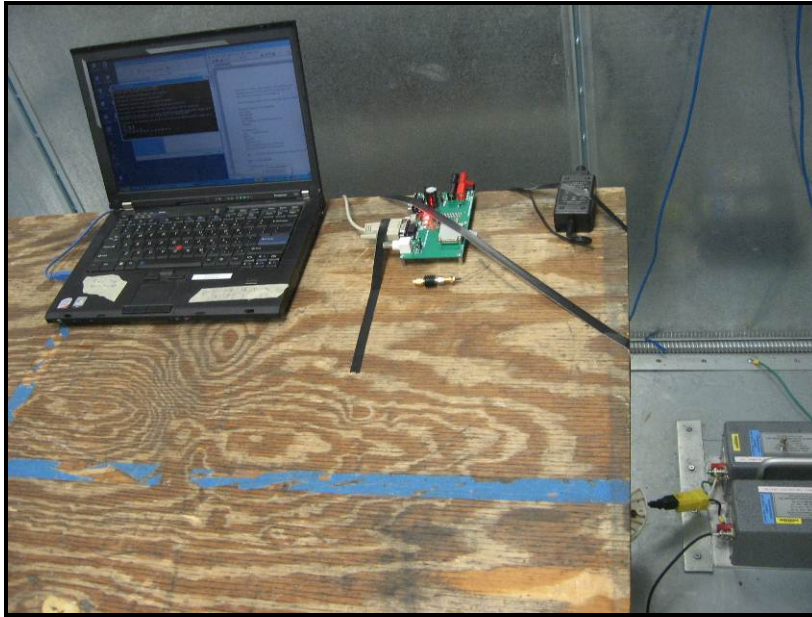

**END OF REPORT**