

IRIDIUM

9601 Short Burst Data Only Transceiver Preliminary Product Developers Guide

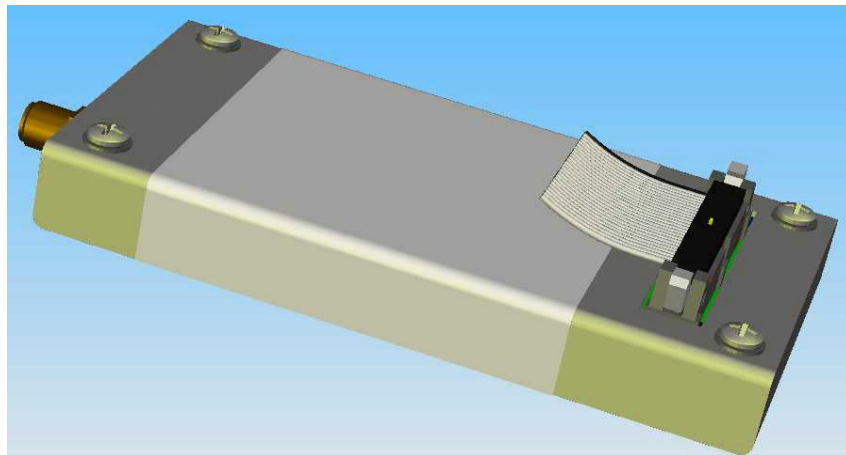

Revision 1.2
August 28th 2005

Iridium Satellite LLC Proprietary & Confidential Information

Iridium Satellite LLC
6701 Democracy Blvd., Suite 500
Bethesda, MD 20817 USA
www.iridium.com

Toll Free: +1.866.947.4348 [US Only]
International +1.480.752.5155
email: info@iridium.com

Preliminary Product Information Purpose & Disclaimer

This document contains preliminary product information for the new Iridium 9601 Short Burst Data Transceiver. The purpose of providing this information is to enable Value Added Resellers and Value Added Manufacturers to begin to understand the product and how to integrate it into a complete wireless data solution.

By providing the information contained herein, Iridium Satellite LLC makes no guarantee or warranty, and does not assume liability with respect to the accuracy or the completeness of such information, or to the results of use of the planned product in any specific instance, and hereby expressly disclaims any implied warranties of merchantability or fitness for a particular purpose, or any other warranties or representations whatsoever, expressed or implied.

Iridium Satellite LLC reserves the right to modify or change specifications, detailed herein, at any time without notice.

Export Compliance Information

This product is controlled by the export laws and regulations of the United States of America. The U.S. Government may restrict the export or re-export of this product to certain individuals and/or destinations. For further information, contact the U.S. Department of Commerce, Bureau of Industry and Security or visit www.bis.doc.gov.

Revision History

Revision	Date	Comment
V1.0	May 02 2005	First revision
V1.2	Aug 28 2005	Second revision incorporating major updates. Key updates are: Product name change to "9601 SBD Transceiver" Physical packaging Connector types updated AT Commands added and updated

Contents

Preliminary Product Information Purpose & Disclaimer	2
Revision History.....	2
List of Abbreviations	4
1.0 Product Overview	5
1.1 Key Features	5
1.2 Transceiver Packaging and Regulatory Certification	6
2.0 Physical Specifications	7
2.1 Dimensions	7
2.2 Mechanical Dimensions – Mounting.....	9
2.2.1 Mounting - Stackable Design.....	10
2.2.2 Mounting to a Panel/Surface – For use with cable connections	12
2.3 Environmental.....	14
2.4 Interface Connectors	14
3.0 Electrical Interfaces	15
3.1 Multi-Interface Connector	15
3.1.1 Connector Type	15
3.1.2 Connector Pin Allocation	16
3.2 DC Power Interface	18
3.2.1 Power On/Off Control	18
3.3 Serial Data Interface.....	19
3.3.1 9-Wire and 3-Wire Operation.....	19
3.3.2 Configuration Settings	20
3.3.3 Modes of Operation	21
3.4 Hardware Failure Reporting	21
3.5 Network Available Output	21
3.6 DC Power Output	21
4.0 RF Interface	22
4.1 Antenna Connector.....	22
4.1.1 Antenna Connector Type.....	22
4.2 RF Interface Specifications	23
4.3 Radio Characteristics	23
5.0 Modem Commands and Configuration.....	24

List of Abbreviations

Abbreviation	Description
CE	Conformité Européene
DC	Direct Current
DTE	Data Terminal Equipment
ESS	ETC SBD Subsystem
ETC	Earth Terminal Controller
FA	Field Application
FCC	Federal Communications Commission
GND	Ground
IC	Industry Canada
LBT	L-Band Transceiver
MOMSN	Mobile Originated Message Sequence Number
MTMSN	Mobile Terminated Message Sequence Number
RHCP	Right Hand Circular Polarization
SBD	Short Burst Data
SMS	Short Message Service
TBA	To Be Advised
VAM	Value Added Manufacturer
VAR	Value Added Reseller
VSWR	Voltage Standing Wave Ratio

1.0 Product Overview

The Iridium 9601 Short Burst Data Only Transceiver (9601) is designed to be integrated into a wireless data application with other hardware and software to produce a full solution designed for a specific application or vertical market. Examples of these solutions include a tracking a maritime vessel or automatic vehicle location.

The 9601 only supports Iridium's Short Burst Data (SBD) capability. It does not support voice, circuit switched data, or short message service (SMS). This is a new product and has no functional predecessor.

The 9601 will be designed to meet the regulatory requirements for approval for FCC, Canada, and CE assuming an antenna with a gain of ~3 dBi and adequate shielding. This allows the 9601 to be integrated into a variety of wireless data applications or retrofitted into existing SBD only applications that utilize SBD with the current Iridium 9522A or 9522 L-Band Transceiver-based product. (Note that additional development work will be required.) Such finished products, when integrated together, require regulatory testing to be conducted by the integrator.

The 9601 is designed as a single board transceiver and is essentially provided as a 'black box' transceiver with all device interfaces provided by a single multi-pin interface connector in addition to the antenna connector. The product only provides the core transceiver. All other end user application functions such as GPS, microprocessor based logic control, digital and analog inputs, digital and analog outputs power supply and antenna must be provided by the solution developer. The device interface consists of the serial interface, power input, network available output and power on/off control line.

The 9601 does not incorporate nor require a Subscriber Identity Module (also know as a SIM Card) to be inserted into the transceiver. The 9601 will be designed to comply with the standards for Radio Emissions Compliance, Electromagnetic Compatibility, and AC Safety in the United States, European Union and Canada.

The 9601 is described within this document as "9601", "9601 Transceiver" and "9601 SBD Transceiver" all of these terms refer to the same product.

1.1 Key Features

- Single board transceiver
- Small form factor
- No SIM card
- Designed to be incorporated into an OEM solution
- Maximum mobile originated message size 205 bytes (subject to revision)
- Maximum mobile terminated message size 135 bytes (subject to revision)
- Uses small omni-directional antenna
- Global operating capability

1.2 Transceiver Packaging and Regulatory Certification

The 9601 Transceiver is a regulatory approved transceiver that is provided in an enclosure and with appropriate connectors that permit the full transceiver to be regulatory tested by Iridium and sold as a Regulatory Certified product that meets CE, FCC and IC requirements.

The 9601 is tested to the regulatory and technical certifications shown in Table 1.

Table 1: Regulatory and Technical Certifications.

Regulatory Approvals	Radio Tests	EMC Tests	Electrical / Mechanical / Operational Safety Tests
CE FCC Industry Canada	ETSI EN 301 441 V1.1.1 (200005) FCC parts 2, 15, and 25 Industry Canada RSS170 Issue 1, Rev 1, November 6, 1999	ETSI EN 301 4891 V1.4.1 (200208) ETSI EN 301 48920 V1.2.1(200211) EN6100042 : 1995 / A2 : 2001 EN6100043 : 2002 EN6100044 : 2004 EN6100046 : 1996 / A1 : 2001 EN55022:1998/A1:2000/A2:2003 (see clause 8.3 of ETSI EN301 4891 V1.4.1)	EN609501:2001 Part 1

2.0 Physical Specifications

For illustrative purposes a rendering of the 9601 ISU is shown in Figure 1 with a ribbon cable connector inserted. (Note that the ribbon cable and connector is to be provided by the developer and is not supplied as part of the commercial product.)

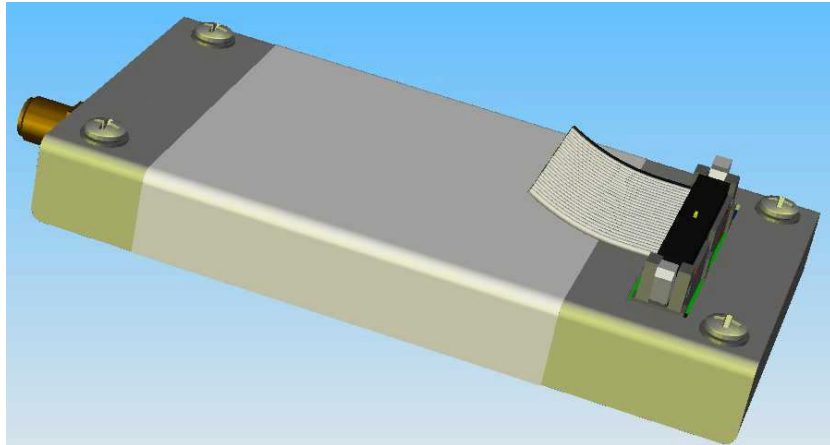

Figure 1: The 9601 Transceiver.

2.1 Dimensions

The overall dimensions of the 9601 and its weight are summarized in Table 2 and represented graphically in third angle projection in Figure 2

Table 2: 9601 Mechanical Dimensions

Parameter	Value
Length	106 mm
Width	56.2 mm
Depth	13 mm
Weight (approximate)	TBA

Note that these dimensions are for the enclosure and do not take into account the connectors or mounting hardware. Additionally developers should plan for additional space for the reciprocal connectors for the antenna and user connector.

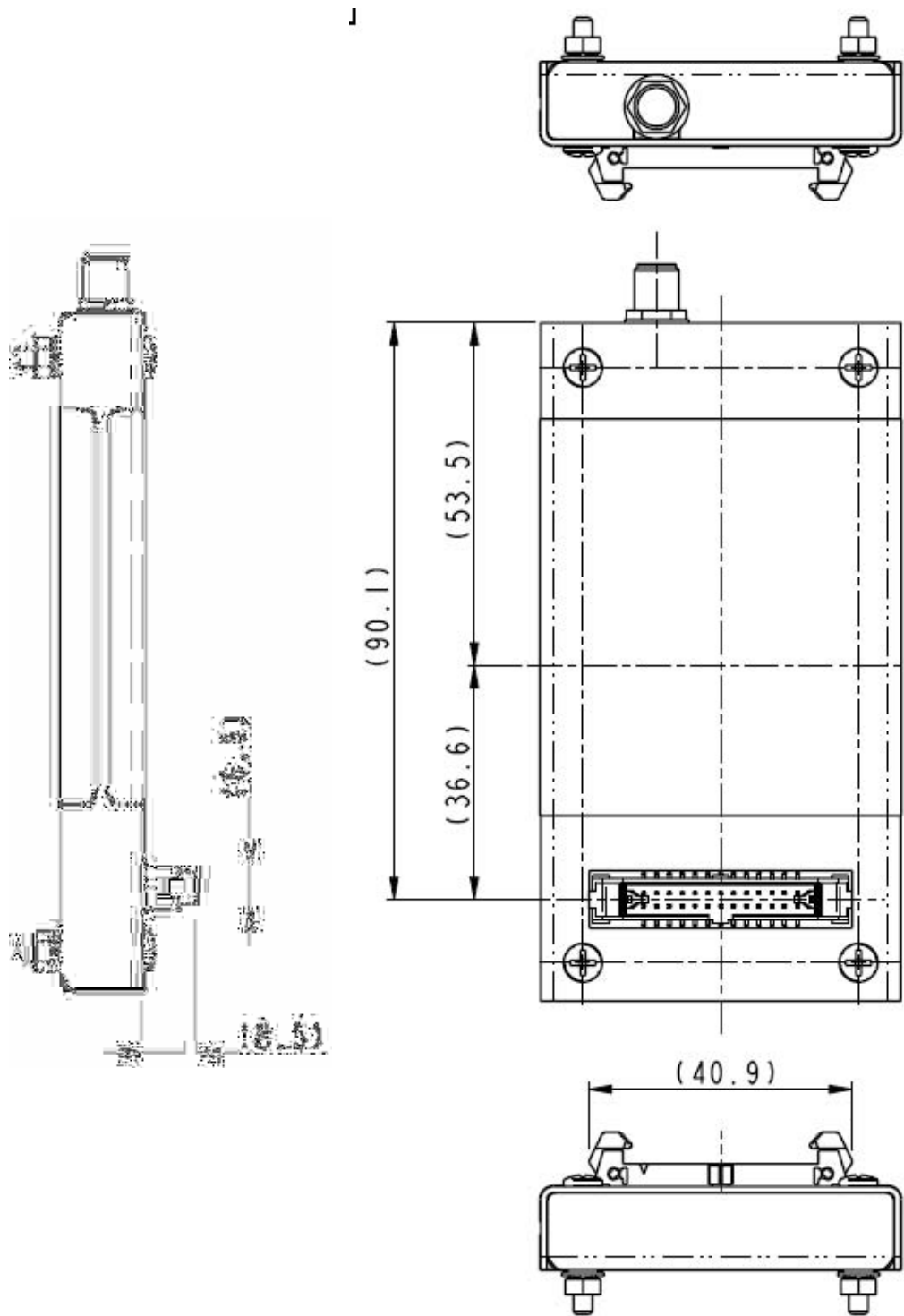

Figure 2 (Part 1 of 2): Dimensions of the 9601 Transceiver.
(Not to scale, dimensions in millimeters)

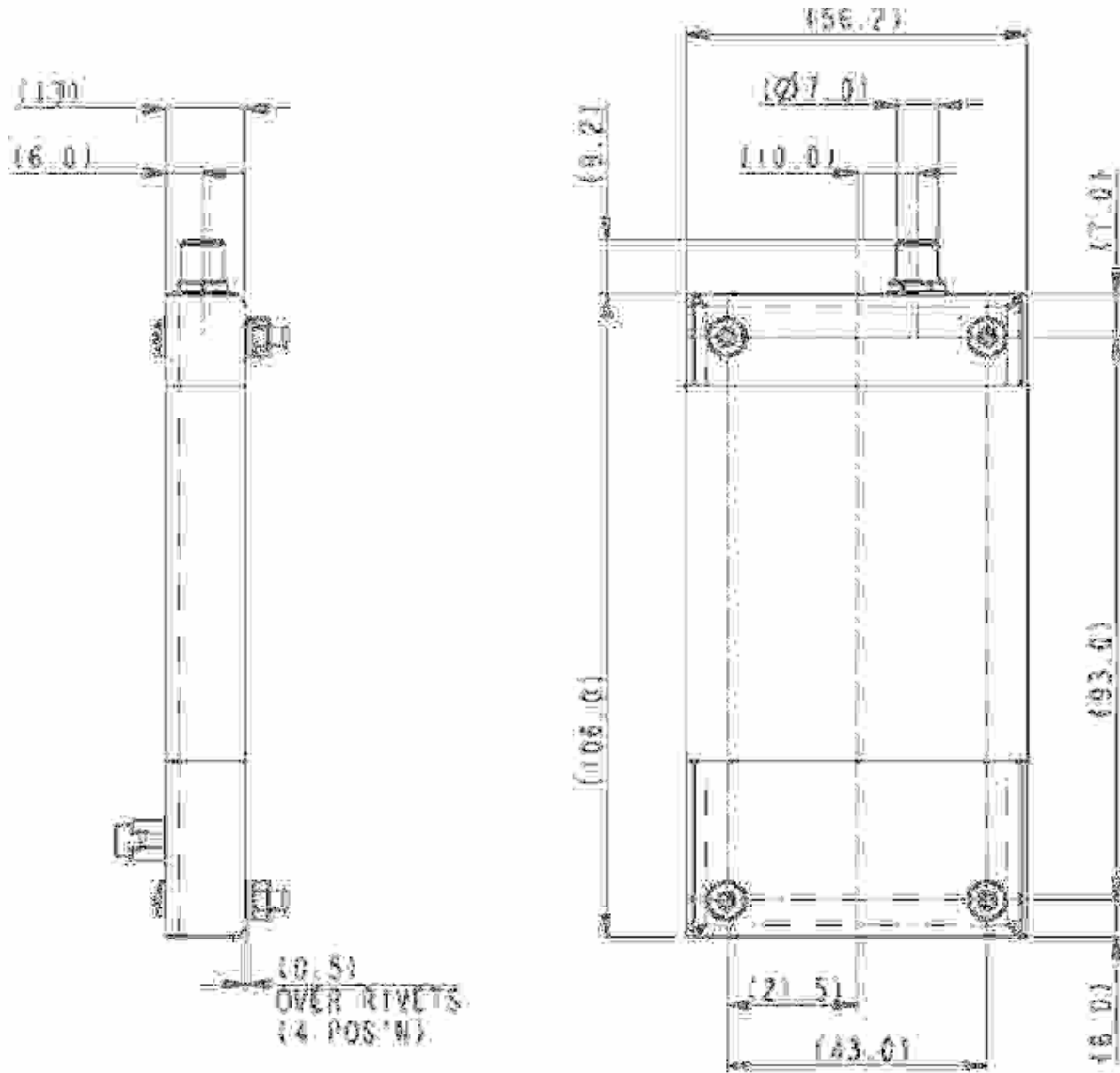

Figure 2 (Part 2 of 2): Dimensions of the 9601 Transceiver.
 (Not to scale, dimensions in millimeters)

2.2 Mechanical Dimensions – Mounting

The 9601 Transceiver is provided with four mounting holes, one at each corner. During manufacture four screws are inserted for shipping purposes. These screws need to be removed for mounting. There are two basic options for mounting – stackable and mounting to a surface such as a mounting plate or enclosure wall. The following sections provide further information.

2.2.1 Mounting - Stackable Design

An example stackable design is shown in Figure 3.

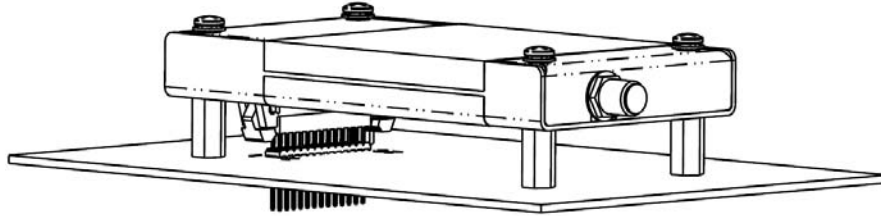

Figure 3: 9601 Transceiver mounted to a unpopulated PCB.

The figures and tables below provides mechanical information design information for a suitable 'stackable' 9601 to developer PCB configuration

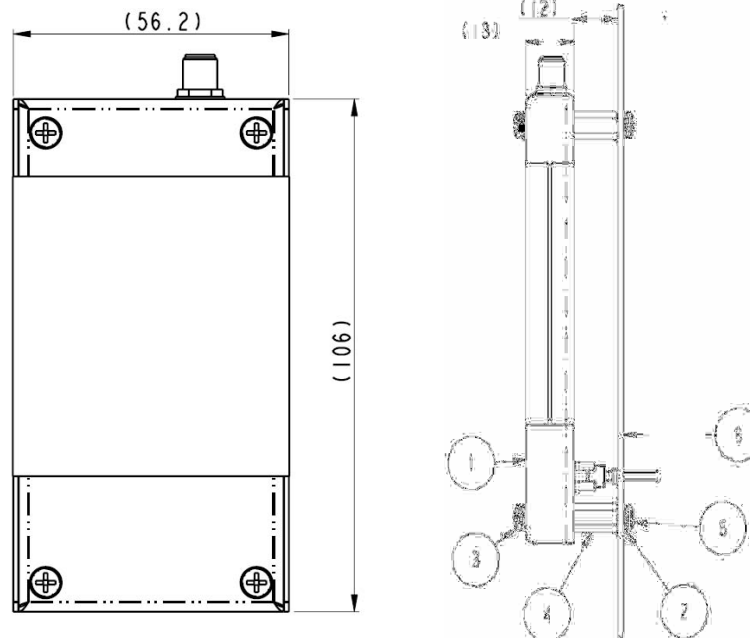

Figure 4: Assembly Item Number Identification.

Item Numbers in Figure 4 are described in Table 3. Not to scale. Dimensions in millimeters.

Table 3: Item Number Description for Figure 4

Item	Type	Description	Quantity
1	Assembly	9601 Transceiver	1
2	Part	M3 Shake-proof washer, zinc plated steel [4 supplied with item 1]	8
3	Part	M3 x 20 Pan head screw, pozidrive, zinc plated steel [4 supplied with item 1]	4
4	Part	M3 Threaded standoff, 6.0 A/F HEX x 12.00 mm	4
5	Part	M3 x 8 Pan head screw, pozidrive, zinc plated steel	4
6	Assembly	Solution developer PCB fitted with Samtec connector ESQT-113-02-L-D-425. [This item is the same item as Item 1 in Figure 5.]	1

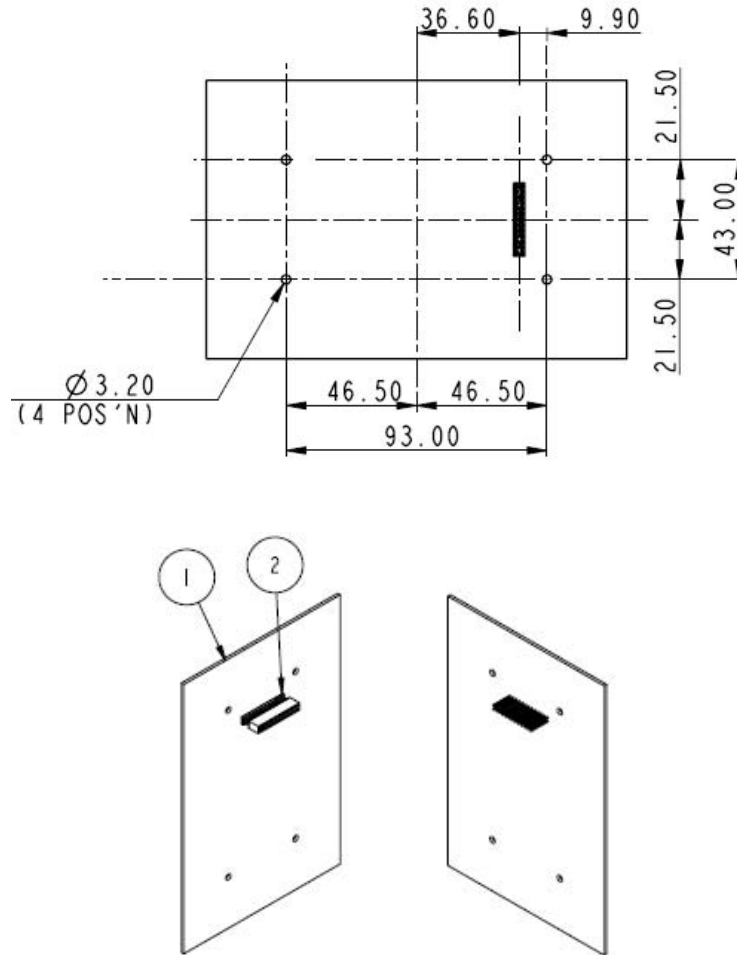

Figure 5: Mechanical mounting foot print for use when stacking the 9601 with a developer provided PCB. (Dimensions in milli-meters, not to scale)

Notes for Figure 5:

1. Item 1 is a generic, developer provided PCB design and shown for illustrative purposes. This item is the same as Item 6 in Figure 4.
2. Item 2 is available from Samtec in a variety of heights. This example shows a 0.425" version. The part number for this connector is ESQT-113-02-L-D-425
3. Compatible heights of stand-offs and variants on Item 2 are as follows:
 - a. 0.425" height (shown) fits with 12mm high spacers
 - b. 0.327" height is minimum that can be used. Fits with 9.50mm spacers.
 - c. 0.800" height is the maximum height available fits with 21.50mm spacers.
 - d. Anything else in-between should work if 'Samtec height' = 'Spacer height' minus 1.20mm.
4. Suggested examples of spacer types and compatible fasteners:
 - a. M3 threaded thru' hole 6.0 A/F Hex x 12mm, re-use M3 x 20 shipping screws and washers, add M3 x 8 screws and washers.
 - b. Plain thru' hole diameter 3.2-3.5, diameter 6.0 x 9.50mm, replace M3 x 20 shipping screws with M3 x 30 screws (same nuts and washers.)
 - c. Plain thru' hole diameter 3.2-3.5, diameter 6.0 x 21.50mm, replace M3 x 20 shipping screws with M3 x 35 screws (same nuts and washers.)

2.2.2 Mounting to a Panel/Surface – For use with cable connections

An example of mounting to a panel or other surface design is shown in Figure 6.

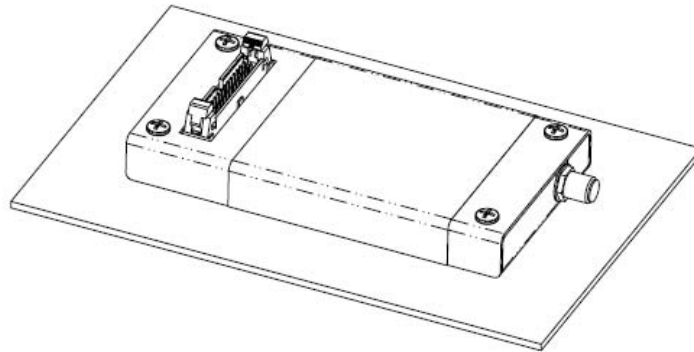

Figure 6: 9601 Transceiver mounted to a plate or surface.

The figures and tables below provide mechanical information design information for a mounting a 9601 to a plate or surface configuration

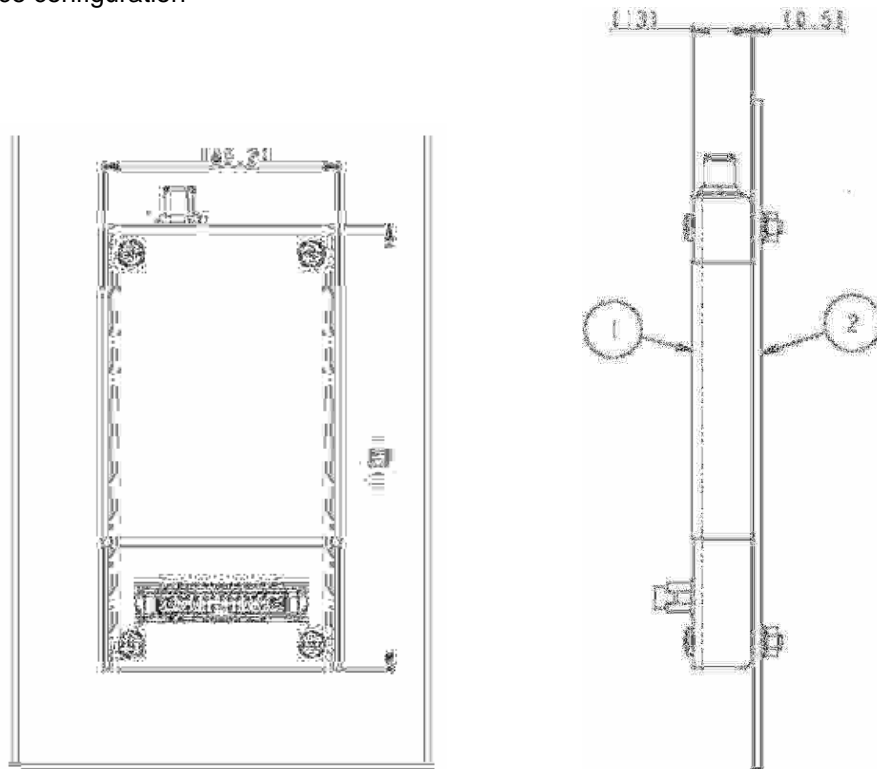

Figure 7: Assembly Item Number Identification.

Item Numbers in Figure 7 are described in Table 4. (Not to scale. Dimensions in millimeters.)

Notes for Figure 7:

1. Item 1 includes 4 off M3 x 20 shipping screws, shake-proof washers and nuts
2. Shipping screws can be used to attach Transceiver to panel of 2.00 mm maximum thickness
3. Panels thicker than 2.00mm require longer screws to be e.g. M3 x 25mm
4. See Figure 8 for mounting hole dimensions

Table 4: Item Number Description for Figure 7

Item	Type	Description	Quantity
1	Assembly	9601 Transceiver	1
2	Part	Mounting Plate or Surface (developer provided)	1

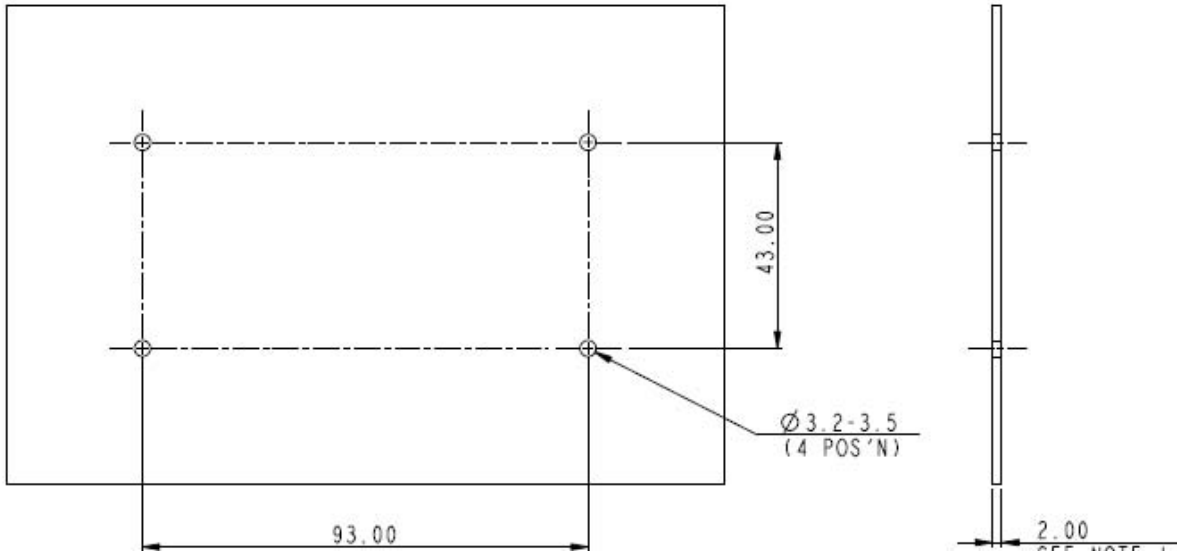

Figure 8: Mechanical mounting foot print for use when panel mounting 9601.
 (Dimensions in milli-meters, not to scale)

2.3 Environmental

The environmental specifications of the 9601 are summarized in Table 5 below.

Table 5: Environmental Specifications

Parameter	Value
Operating Temperature Range	-30°C to + 60°C
Operating Humidity Range	≤ 75% RH
Storage Temperature Range	-40°C to + 85°C
Storage Humidity Range	≤ 93% RH

The 9601 has been tested to the specifications listed in Table 6.

Table 6: Environmental Tests

Test Name	Test Reference	Test Description
Thermal Shock	EN60068-2-14:2000	Change of Temperature, -25C to +70C, 5 cycles of 1 hour each
Humidity	IEC60068-2-3:1969	Damp heat steady state 40C 93% RH for 4 days
Shock	EN60068-2-27:1993 (NF c20-727)	
Shock	J1455 Society of Automotive Engineers	
Vibration	EN 60068-2-36:1996	Sinusoidal Vibration 0.96 m2/s3 from 5Hz to 20Hz
Vibration	IEC 60068-2-36:1996	Sinusoidal Vibration 21Hz to 500Hz -3dB per octave
Vibration	J1455 Society of Automotive Engineers	

2.4 Interface Connectors

The 9601 Transceiver incorporates two connectors:

- A multi-interface connector
- An antenna connector

These interfaces are described in more detail in Sections 3 and 4 respectively.

3.0 Electrical Interfaces

The subsections to follow contain information for the electrical interfaces of the 9601 Transceiver.

3.1 *Multi-Interface Connector*

The multi-interface connector includes six interfaces:

- DC power supply input
- Power on/off control
- RS-232 Serial data
- Network available output
- DC power output

3.1.1 Connector Type

The connector on the 9601 is a Samtec EHT series. This connector provides the ability for both a cable connector as well as a stackable board to board connection. For cable connected applications use the Samtec TCSD series. For PCB stacking use the Samtec ESQT series.

Data sheets on these connectors can be found at:

EHT Series: http://www.samtec.com/technical_specifications/overview.asp?series=EHT

TCSD Series: http://www.samtec.com/technical_specifications/overview.asp?series=tcsd

ESQT Series: http://www.samtec.com/technical_specifications/overview.asp?series=esqt

3.1.2 Connector Pin Allocation

The user connector is a 2 row 26-way latching header. Individual pin assignments are shown in Table 7. Multiple supply grounds are provided and all supply and supply grounds (pins 1-6) are required to be connected to the power supply in order to limit the current on any one pin. The three Supply Returns (pins 4, 5 & 6) are tied together at the connector as well as the three Supply pins (pins 1, 2 & 3.) Multiple signal grounds are provided to reduce cross-talk. The signal grounds on pins 10,13, 20 & 23 are all tied together at the connector and can be joined with any of the signal wires e.g. RS232, Network Available etc. However each signal requires its own signal ground in order to limit current on any one pin.

Table 7: Multi Interface Connector Pin Allocation

Pin No.	Signal Name	Signal direction (WRT 9601)	Signal function	Signal level
1	EXT_PWR	Input	Supply	+5 V +/- 0.5 V
2	EXT_PWR	Input	Supply	+5 V +/- 0.5 V
3	EXT_PWR	Input	Supply	+5 V +/- 0.5 V
4	EXT_GND		Supply return	0 V
5	EXT_GND		Supply return	0 V
6	EXT_GND		Supply return	0 V
7	ON/OFF	Input	On/Off control input	On: 2.0V to Vsupply Off: 0V to 0.5V I = 120 µA max
8	Reserved			
9	Reserved			
10	SIG_GND		Signal ground	0V
11	DF_S_TX	Input	Data port, serial data into data module	RS-232
12	DF_S_RX	Output	Data port, serial data from data module	RS-232
13	SIG_GND		Signal ground	0V
14	DF_DCD	Output	Data port, Data Carrier Detect	RS-232
15	DF_DSR	Output	Data port, Data Set Ready	RS-232
16	DF_CTS	Output	Data port, Clear-to-Send	RS-232
17	DF_RI	Output	Data port, Ring Indicator	RS-232
18	DF_RTS	Input	Data port, Request-to-Send	RS-232
19	DF_DTR	Input	Data port, Data Terminal Ready	RS-232
20	SIG_GND		Signal ground	0V
21	Reserved			
22	Reserved			
23	SIG_GND		Signal ground	0V
24	NETWORK_AVAILABLE	Output	Set to logic 1 when network is visible	2.9 V CMOS
25	Spare			
26	+2V9	Output	Supply output	+2.9 V ± 0.15 V, 50mA maximum

Figure 9 provides a reference for the pin designation. Note that this designation is when looking into the multi-interface connector from above. It is not to scale and not representative of the actual connector mechanical layout.

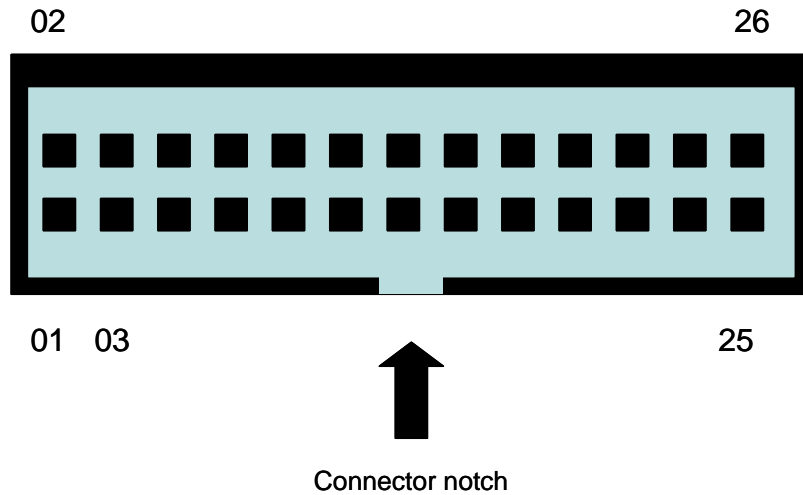

Figure 9: Multi-Interface Connector Pin Number Designation

Notes:

1. View looking into connector from above
2. Numbers indicate pin designations
3. Not to scale, for illustrative purposes only
4. Note location of connector notch
5. Connector notch faces towards opposite end to the antenna connector as shown in Figure 10
6. On the physical connector Pin 1 is indicated by an arrow mark

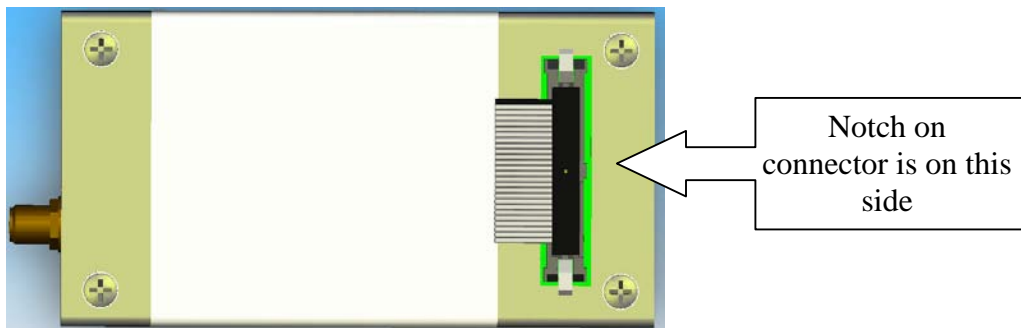

Figure 10: Multi Interface Connector Notch Location

3.2 DC Power Interface

The DC power interface is comprised of the DC power inputs and a control signals as summarized in Table 7. The three +5V Inputs and three 0V supply returns are used to supply DC power to the 9601 and ensure that enough current can be drawn across the connector without the 9601 malfunctioning during transmit due to lack of current supply. Note that all six pins should be connected.

The DC power supply requirements for the 9601 are summarized in Table 8 below. Note that these requirements apply to DC power measured at the 9601 multi-interface connector input and not at the output of the power supply. Long power supply cables can cause a voltage drop sufficient to cause the voltage to be out of specification at the physical power supply input to the 9601.

Table 8: DC Power Input Specifications

Parameter	Value
Main Input Voltage Range	+4.5 VDC to +5.5 VDC
Main Input Voltage Nominal	5.0VDC
Main Input Voltage – Ripple	40 mV pp
Consumption at +5.0 VDC	
Input Standby Current (average)	100mA
Peak Transient Current – Transmit	<= 2.0A
Current Average – when SBD message transfer in process	<= 350 mA
Average Power consumption – when SBD message transfer in process	<= 1.75 W

Note: The average power consumption depends on the view of the satellite constellation from the antenna.

The external power supply needs to **guarantee** the following:

- The supply voltage droop over an 8.3mS burst should not be more than 0.2 Volts.
- The power supply should limit the in-rush current to 4 Amps maximum
- The supply noise should be less than that in the following profile (linear interpolation between these points):
 - 100 mV pk-pk 0Hz to 50 kHz
 - 5 mV pk-pk in 50 kHz bandwidth at 1 MHz
 - 10 mV pk-pk in 1 MHz bandwidth at 1 MHz
 - 5 mV pk-pk in 1 MHz bandwidth above 5 MHz.

3.2.1 Power On/Off Control

An external on/off input is provided on a pin of the multi-interface connector. The 9601 starts up when power is applied and the power on/off input is high. As long as the input voltage is applied, logic high on this line turns the transceiver on and a logic low turns it off. If this line is not required then it must be connected directly to the +5 V supply. The input logic high threshold is 2.0 V and the logic low threshold is 0.5 V.

Note that this on/off control is **not** the same as the 9522 or 9522A.

3.3 Serial Data Interface

The Serial data interface is used to both command the 9601 and transfer user data to and from the Transceiver. The 9601 presents a 9-wire data port to the FA (Field Application), where the interface is at RS232 levels. With respect to this interface, the Data Module behaves as a DCE (Data Communication Equipment), and the FA behaves as a DTE (Data Terminal Equipment).

The terms “FA” and “DTE” are used interchangeably throughout this document; similarly for the terms “Data Module” and “DCE”.

Autobaud is not supported in 9601 Transceiver. The baud rate can be set via the AT+IPR command. The default rate is 19200 bps.

3.3.1 9-Wire and 3-Wire Operation

By default, the serial interface operates as a 9-wire connection. Table 9 describes each of the signals, where “input” means an input to the Data Module, and “output” means an output from the 9601 Transceiver.

Table 9 – Serial Interface Signals

Signal	Description
RX	Active high data input
TX	Active high data output
GND	0V
RTS	Active low flow control input
CTS	Active low flow control output RTS and CTS are used together to implement hardware flow control when enabled with AT&K3
DTR	Active low handshaking input AT&Dn controls how the Data Module uses DTR: <ul style="list-style-type: none"> • If set to AT&D0, DTR is always ignored. • Otherwise DTR set to OFF places the data port into UART test mode after 10 seconds, or immediately on boot-up. A subsequent transition of DTR to ON returns the data port to DCE mode and resets it to its power-on state. • The UART test mode is provided for factory testing of the data port UART. An FA should never activate test mode; if it does, the Data Module will stop responding to AT commands until the data port is returned to DCE mode.
DSR	Active low handshaking output The Data Module drives DSR ON when the data port is in DCE mode, and OFF when the data port is in test mode. The DTE may use this signal as an indication that the Data Module is powered up and ready to receive AT commands.
RI	Active low ring indicator output The Data Module drives RI ON when it receives a ring alert from the network, and drives RI OFF after 5 seconds or when the DTE initiates an SBD session, whichever occurs first.
DCD	Active low handshaking output DCD is driven ON at all times.

Note that the Ring Indicator (RI) pin is used by the 9601 Transceiver to indicate that a Mobile Terminated SBD (MT-SBD) message is queued at the Gateway. The Field Application will need to monitor this pin and use appropriate AT Commands to command the Transceiver to retrieve the MT-SBD message.

The serial interface may be operated with a 3-wire connection, where only transmit, receive and ground signals are used. However the 9 wire interface offers better control and is the recommended implementation. Iridium is only able to provide limited 3-wire interface support. When operating with a 3-wire connection, the following rules apply:

- AT&Dn must be set to AT&D0 to ignore the DTR input
- AT&Kn must be set to AT&K0 to disable RTS/CTS flow control
- The other output signals may be connected, and operate as follows:
 - CTS driven ON (low)
 - DSR operates as normal
 - RI operates as normal
 - DCD driven ON (low)

Note: RTS/CTS flow control, when enabled, is only used when the data port is in SBD data mode. In AT command mode, RTS is ignored and CTS is driven ON (low).

3.3.2 Configuration Settings

The Data Module allows the DTE to configure the data port communication parameters. The three configuration types are active, factory default, and stored. The active configuration is the set of parameters currently in use. They can be changed by the DTE individually via specific AT commands. The factory default configuration is stored in permanent memory. This configuration can be recalled at any time through use of the AT&Fn command.

Two groups of settings, or “profiles”, can be stored as user-defined configurations. The DTE first creates desired active configurations and then writes them to memory using the AT&Wn command. These profiles can be designated to be loaded as the active configuration upon Data Module power-up through use of the AT&Yn command. The Data Module can be reset without loss of power to these profiles through use of the ATZn command.

The configuration settings are stored in “S-register” locations.

3.3.3 Modes of Operation

The serial interface is always in one of three modes: command mode, SBD data mode or SBD session mode. When the data port is in command mode, AT commands can be entered to control the Data Module. In command mode, flow control has no effect, with the RTS input ignored and the CTS output driven ON (low). When in SBD data mode, the Data Module is transferring binary or text SBD message data to or from the DTE.

In SBD data mode:

- All characters from the DTE not forming part of the message data are ignored (i.e. no AT commands may be entered)
- No unsolicited result codes are issued.
- RTS/CTS flow control, if enabled, is active. When RTS is OFF (high), the Data Module suspends transfer of data to the DTE; when CTS is OFF (high), the Data Module expects the DTE to suspend transfer of data to the Data Module.

When in SBD session mode, the Data Module is attempting to conduct an SBD session with the network. In SBD session mode:

- The DTE must wait for the +SBDI session result code.
- All characters from the DTE are ignored.
- Unsolicited result codes are issued where those codes have been enabled.

Transitions between the modes of operation are performed automatically by the Data Module in response to the SBD AT Commands; the DTE has no other control over the mode.

3.4 Hardware Failure Reporting

If the Data Module detects a hardware problem during initialisation, the Data Module may be unable to function correctly. The Data Module notifies the DTE of this situation by issuing an unsolicited result code at the end of initialisation:

```
HARDWARE FAILURE: <subsys>,<error>
```

where <subsys> identifies the software subsystem that detected the error, and <error> is the subsystem-specific error code.

Any AT commands that cannot be handled in the failure condition will terminate with result code 4 ("ERROR").

3.5 Network Available Output

This is a digital output that can be used by an application to know when the Transceiver has visibility to the satellite network. This is useful in applications where the Transceiver may move around terrain that reduces the amount of time that clear line of sight to the satellite constellation is available. The application developer can use this output to preserve battery life by reducing the number of attempted transmissions by including this logic output in the application decision logic.

3.6 DC Power Output

A limited power output can be provided by the 9601 which could be used for driving an LED to provide a visible indication that the transceiver is on, or the output could be used in application logic to determine if the transceiver is on.

4.0 RF Interface

This section describes the physical connector and RF specifications of the RF Interface.

4.1 Antenna Connector

The 9601 will have the following antenna connector characteristics as described in Table 10.

Table 10: Antenna Characteristics

Parameter	Value
Impedance	50 Ohms nominal
Gain	3dBi
Polarization	RHCP
VSWR (maximum operational)	1.5 : 1

Note:

- Existing qualified Iridium antennas may be used. (i.e. antennas designed for the 9522 and 9522A)
- Existing antennas will require different RF connector types to those for the 9522 and 9522A
- The receiver will automatically shut down if a VSWR of 3:1 or greater is detected.

4.1.1 Antenna Connector Type

The antenna connector on the 9601 is a female SMA type. The connector is manufactured by Johnson Components and has a part number: 142-0701-871. Additional information can be found at:

<http://www.johnsoncomponents.com/webapp/wcs/stores/servlet/ENPPProductDetailView?itemid=20525&storeId=10010&catalogId=10010&langId=-1>

A data sheet may be downloaded from:

<http://www.johnsoncomponents.com/webapp/wcs/stores/Johnson/pdfs/1420701871.pdf>

4.2 RF Interface Specifications

The RF interface requirements for the 9601 are summarized in Table 11 below.

Table 11: General RF Parameters

Parameter	Value
Frequency Range	1616 MHz to 1626.5 MHz
Duplexing Method	TDD (Time Domain Duplex)
Oscillator Stability	± 1.5 ppm
Input/Output Impedance	50Ω
Multiplexing Method	TDMA/FDMA

4.3 Radio Characteristics

The tables within this section contain radio characteristics of the 9601 Transceiver.

Table 12: In-Band Characteristics

Parameter	Value
Average Power during a transmit slot (max)	1.6 W

Table 13: Link Margin

Configuration	Cable Loss	Link Margin
9601 Transceiver antennas (Note 1)	2 dB (Note 2)	13.1 dB (Note 3)

Note that the total implementation loss for an antenna, connectors, cable, lightning arrestor and any other RF component between the transceiver and the antenna shall not exceed 3dB. Implementation loss higher than this will affect link performance and quality of service.

Note 1: This Transceiver has a different antenna connector to other Iridium transceivers

Note 2: Cable losses should be minimized.

Note 3: Link Margin given for free space.

5.0 Modem Commands and Configuration

9601 Transceiver - AT Command Set Table of Contents

Glossary	3
1 Introduction	4
2 AT Commands	4
2.1 AT – ATtention Code	4
2.2 A/ - Repeat Last Command	4
2.3 En – Echo	4
2.4 In – Identification	4
2.5 Qn – Quiet Mode	5
2.6 Vn – Verbose Mode	5
2.7 Zn – Soft Reset	5
2.8 &Dn – DTR Option (<i>modified</i>)	5
2.9 &Fn – Restore Factory Settings	5
2.10 &Kn – Flow Control (<i>modified</i>)	6
2.11 &V – View Active and Stored Configuration	6
2.12 &Wn – Store Active Configuration	6
2.13 &Yn – Designate Default Reset Profile	6
2.14 %R – Display Registers	6
2.15 *F – Flush to Eeprom (<i>new</i>)	6
2.16 *Rn – Radio Activity (<i>new</i>)	7
2.17 +CGMI – Manufacturer Identification	7
2.18 +CGMM – Model Identification	7
2.19 +CGMR – Revision	7
2.20 +CGSN – Serial Number	7
2.21 +CIER – Indicator Event Reporting (<i>new</i>)	7
2.22 +CSQ – Signal Quality	10
2.23 +CULK – Unlock (<i>new</i>)	10
2.24 +GMI – Manufacturer Identification	11
2.25 +GMM – Model Identification	11
2.26 +GMR – Revision	11
2.27 +GSN – Serial Number	12
2.28 +IPR – Fixed DTE Rate	12
2.29 +SBDWB – Short Burst Data: Write Binary Data to the Module	12
2.30 +SBDRB – Short Burst Data: Read Binary Data from the Module	13
2.31 +SBDWT – Short Burst Data: Write a Text Message to the Module	14
2.32 +SBDRT – Short Burst Data: Read a Text Message from the Module	15
2.33 +SBDI – Short Burst Data: Initiate an SBD Session	16
2.34 +SBDDDET – Short Burst Data: Detach (<i>new</i>)	17
2.35 +SBDDSC – Short Burst Data: Delivery Short Code	18
2.36 +SBDIX – Short Burst Data: Initiate an SBD Session Extended (<i>new</i>)	19
2.37 +SBDMTA – Short Burst Data: Mobile-Terminated Alert (<i>new</i>)	21
2.38 +SBDREG – Short Burst Data: Network Registration (<i>new</i>)	22
2.39 +SBDAREG – Short Burst Data: Automatic Registration (<i>new</i>)	24
2.40 +SBDD – Short Burst Data: Clear SBD Message Buffer(s)	26
2.41 +SBDC – Short Burst Data: Clear SBD MOMSN	27
2.42 +SBDS – Short Burst Data: Status	27

2.43	+SBDTC – Short Burst Data: Transfer MO Buffer to MT Buffer	28
2.44	-MSSTM – Request System Time	28
3	S-Register Definitions	30
3.1	S-Register Commands	30
3.1.1	Sr – Direct S-Register Reference	30
3.1.2	Sr? – Direct S-Register Read	30
3.1.3	Sr=n – Direct S-Register Write	30
3.1.4	? – Referenced S-Register Read	30
3.1.5	=n – Referenced S-Register Write	31
3.2	S-Registers	31
4	Summary of Result Codes	38
5	Informative Examples	39
5.1	Setting the Default Configuration	39
5.2	Power-on to Sending a Message	40
5.3	Ring Alert Registration	41
5.4	Ring Alert Message Reception	42
5.5	Ring Alert Automatic Registration	43
5.6	Sending a Message with Minimal Radio Activity	44
5.7	Powering Down	45
6	Table of AT Command Changes	46

Glossary

CTS	(V.24 signal) Clear To Send. This signal is used to control the flow of data to the 9601
DCD	(V.24 signal) Data Carrier Detect
DCE	Data Communications Equipment. In this product, DCE refers to the 9601
DSR	(V.24 signal) Data Set Ready. This signal, from the 9601, indicates readiness to accept communication over the data port
DTE	Data Terminal Equipment. In this product, DTE refers to the FA
DTR	(V.24 signal) Data Terminal Ready. This signal, from the FA, requests the 9601 to accept communication over the data port
ESS	ETC SBD Subsystem (synonymous with GSS)
ETC	Earth Terminal Controller, part of the Iridium Gateway
FA	Field Application, the “host” of the 9601
GSS	Gateway SBD Subsystem (synonymous with ESS)
IMEI	International Mobile Equipment Identity
MO	Mobile Originated
MOMSN	Mobile Originated Message Sequence Number
MT	Mobile Terminated
MTMSN	Mobile Terminated Message Sequence Number
RI	(V.24 signal) Ring Indicate. This signal, from the 9601, indicates that an MT message is present at the ESS
RTS	(V.24 signal) Request To Send. This signal is used to control the flow of data from the 9601.
SBD	Short Burst Data
UART	Universal Asynchronous Receiver Transmitter

1 Introduction

This document specifies the AT Commands supported by the 9601 Transceiver. Informative examples are presented in Section 3.

2 AT Commands

The 9601 is configured and operated through the use of AT commands. Only AT Commands that are relevant to the 9601 are included. AT Commands related to functionality of the 9522 and 9522A LBTs are not included. Note that Commands may be modified, removed or added and that you should not rely on this document as a definitive statement of the functionality of the commercial 9601 Transceiver.

2.1 AT – ATtention Code

This is the prefix for all commands except *A/*. When entered on its own, the 9601 will respond OK.

2.2 A/ - Repeat Last Command

Repeat the last command issued to the 9601 unless the power was interrupted or the unit is reset. *A/* is not followed by <CR>.

2.3 En – Echo

Echo command characters.

- 0 Characters are not echoed to the DTE.
- 1 Characters are echoed to the DTE (default).

2.4 In – Identification

Requests the 9601 to display information about itself.

- 0 “2400” (for compatibility only)
- 1 “0000” (for compatibility only)
- 2 “OK” (for compatibility only)
- 3 “XXXXXXXX” (Software revision level)
- 4 “IRIDIUM 9601” (Product description)
- 5 “8816” (for compatibility only)
- 6 “XXX” (Factory identity)

7 “XXXXXXXX” (Hardware specification)

2.5 Qn – Quiet Mode

Control 9601 responses.

- 0 9601 responses are sent to the DTE (default).
- 1 9601 responses are NOT sent to the DTE.

2.6 Vn – Verbose Mode

Set the response format of the 9601, which may be either numeric or textual.

- 0 Numeric responses.
- 1 Textual responses (default).

2.7 Zn – Soft Reset

Reset the 9601’s data port to a user-stored configuration that has been previously stored using &Wn.

- 0 Restores user configuration 0.
- 1 Restores user configuration 1.

2.8 &Dn – DTR Option (*modified*)

Set the 9601 reaction to the DTR signal.

- 0 DTR is ignored. A DTR signal input is not needed when set to &D0.
- 1-3 DTR must be ON. If DTR transitions from ON to OFF, the data port will be locked after approximately 10 seconds to enter the UART test mode. The data port will resume when DTR is restored to ON.

There is no distinction between settings 1-3. (default is 2)

2.9 &Fn – Restore Factory Settings

Recall factory default configuration without resetting the data port.

- 0 Recall factory default 0.

2.10 &Kn – Flow Control (*modified*)

Select the flow control method between the 9601 and DTE. Flow control is only applied to the transfer of SBD message data; it does not apply to AT commands and their responses.

- 0 Disables flow control.
- 3 Enables RTS/CTS flow control (default).

2.11 &V – View Active and Stored Configuration

View the current active configuration and stored profiles.

2.12 &Wn – Store Active Configuration

Store the active profile in non-volatile memory. This is used to store user configurations for later use.

- 0 Store current (active) configuration as profile 0.
- 1 Store current (active) configuration as profile 1.

2.13 &Yn – Designate Default Reset Profile

Select profile for use after power-up.

- 0 Select profile 0 (default).
- 1 Select profile 1.

2.14 %R – Display Registers

Display all the S-registers in the system.

2.15 *F – Flush to Eeprom (*new*)

Flush all pending writes to Eeprom, shut down the radio, and prepare the 9601 to be powered down. The command returns OK upon completion, at which point it is safe to remove the power without losing non-volatile data.

Note: This command stops the 9601 from responding to any more commands, but does not actually power it down. The only way to power down the 9601 is for the FA to remove the power or to de-assert the on/off control line.

Note: After an SBD session, the new SBD MOMSN is always flushed to Eeprom before the +SBDI result is issued.

2.16 *Rn – Radio Activity (*new*)

Control radio activity.

- 0 Disable radio activity.
- 1 Enable radio activity (default).

While the radio is disabled:

- SBD sessions can not be initiated; they will fail immediately.
- No SBD RING alerts will be issued for automatic-MT messages.
- No registration, i.e. location updates will be performed.
- The baseband circuitry is still active and the 9601 still accepts AT commands.

This command allows the FA to reduce detectable emissions from the RF circuitry during the idle periods between SBD sessions, and also provides a degree of power saving in cases where it may be inconvenient for the FA to power down the 9601.

2.17 +CGMI – Manufacturer Identification

Exec Command: +CGMI

Query the 9601 manufacturer.

2.18 +CGMM – Model Identification

Exec Command: +CGMM

Query the 9601 model.

2.19 +CGMR – Revision

Exec Command: +CGMR

Query the 9601 revision.

2.20 +CGSN – Serial Number

Exec Command: +CGSN

Query the 9601 IMEI.

2.21 +CIER – Indicator Event Reporting (*new*)

Set Command: +CIER=[<mode>[,<sigind>[,<svcind>[,<antind>]]]]

The set command enables or disables sending of the +CIEV unsolicited result code from the 9601 to the DTE in case of indicator state changes. <mode> controls the processing of the +CIEV unsolicited result codes.

<mode>:

- 0 Disable indicator event reporting; do not send +CIEV unsolicited result codes to the DTE; buffer the most recent indicator event for each indicator in the 9601 (default).
- 1 Enable indicator event reporting; buffer the most recent +CIEV unsolicited result code for each indicator when the data port is reserved (e.g. in SBD data mode) and flush them to the DTE after reservation; otherwise forward them directly to the DTE.

<sigind>:

Control reporting of "signal quality" indicator changes:

- 0 No "signal quality" indicator reporting.
- 1 Enable "signal quality" indicator reporting using result code

+CIEV:0,<rsssi>

where <rsssi> is:

- 0 Equivalent to 0 bars on the signal strength indicator
- 1 Equivalent to 1 bars on the signal strength indicator
- 2 Equivalent to 2 bars on the signal strength indicator
- 3 Equivalent to 3 bars on the signal strength indicator
- 4 Equivalent to 4 bars on the signal strength indicator
- 5 Equivalent to 5 bars on the signal strength indicator

The reported signal strength is the same value that would be returned by the +CSQ command.

When enabled, the signal quality indicator is reported only when the signal strength changes.

<svcind>:

Control reporting of "service availability" indicator changes:

- 0 No "service availability" indicator reporting.
- 1 Enable "service availability" indicator reporting using result code

+CIEV:1,<value>

where <value> is:

- 0 Network service is currently unavailable.
- 1 Network service is available.

Network service availability is equivalent to a signal strength greater than 0. The service availability indicator provides a way for the FA to wait until the 9601 can start an SBD session without receiving continual notifications of changes in signal strength.

<antind>:

Control reporting of "antenna fault" indicator changes:

- 0 No "antenna fault" indicator reporting.
- 1 Enable "antenna fault" indicator reporting using result code

+CIEV:2,<value>

where <value> is:

- 0 No antenna fault detected, or antenna fault cleared.
- 1 Antenna fault detected, further transmission impossible.

An antenna fault indicates that the antenna is not correctly attached, and in order to protect the transmitter no more transmissions are permitted. On seeing an antenna fault, the user should check the antenna connection; the fault will be automatically cleared once the 9601 detects network service availability again.

Read Command: +CIER?

Query the current indicator event reporting settings. The response is of the form:

+CIER:<mode>,<sigind>,<svcind>,<antind>

Test Command: +CIER=?

List the supported settings. The response is in the form:

+CIER:(supported <mode>S),(supported <sigind>S),(supported <svcind>S)
,(supported <antind>S)

Note: In <mode> 1, the DTE may miss some indicator state changes if they occur while the data port is reserved. However, the buffering mechanism ensures that the *most recent* change for each indicator during reservation will be flushed to the DTE after reservation; thus the DTE is always made aware of the latest state of each indicator.

Note: The DTE may initiate an SBD session even if service is unavailable; in this case, the 9601 makes an immediate search for the network and, if successful, starts the SBD session, otherwise the SBD session fails.

2.22 +CSQ – Signal Quality

Exec Command: +CSQ

Execution command returns the received signal strength indication <rss> from the 9601. Response is in the form:

+CSQ:<rss>

where:

<rss>:

- 0 Equivalent to 0 bars displayed on the signal strength indicator.
- 1 Equivalent to 1 bar displayed on the signal strength indicator.
- 2 Equivalent to 2 bars displayed on the signal strength indicator.
- 3 Equivalent to 3 bars displayed on the signal strength indicator.
- 4 Equivalent to 4 bars displayed on the signal strength indicator.
- 5 Equivalent to 5 bars displayed on the signal strength indicator.

Test Command: +CSQ=?

List the supported signal strength indications. The response is in the form:

+CSQ:(supported <rss>s)

Note: A signal strength response may not be immediately available, but will usually be received within two seconds of issuing the command. If the 9601 is in the process of acquiring the system, a delay in response of up to 10 seconds may be experienced.

2.23 +CULK – Unlock (*new*)

Exec Command: +CULK=<unlock key>

Unlock the Transceiver after it has been locked by the Gateway. The unlock key must be obtained by contacting Iridium's customer support.

<unlock key>:

0000000000000000 .. FFFFFFFFFFFFFFFF

A string of 16 hexadecimal digits.

While the Transceiver is locked, it is unable to perform any SBD sessions. Any attempts to start a session will return an error code indicating that the Transceiver is locked.

Command Response:

+CULK:<status>

where:

<status> indicates the lock status of the Transceiver following the unlock attempt:

- 0 Unlocked – Transceiver is not locked and is permitted to perform SBD sessions.
- 1 Locked – Transceiver is locked and unable to perform SBD sessions. It must be unlocked by supplying the correct unlock key to the +CULK command.
- 2 Permanently locked – Transceiver is locked and unable to perform SBD sessions. It cannot be unlocked and must be returned to the supplier.

Read Command: +CULK?

Query the current lock status of the Transceiver. The response is of the form:

+CULK:<status>

<status>:

- 0 Unlocked
- 1 Locked
- 2 Permanently locked

2.24 +GMI – Manufacturer Identification

Exec Command: +CGMI

Query the 9601 manufacturer.

2.25 +GMM – Model Identification

Exec Command: +CGMM

Query the 9601 model.

2.26 +GMR – Revision

Exec Command: +CGMR

Query the 9601 revision.

2.27 +GSN – Serial Number

Exec Command: +CGSN

Query the 9601 IMEI.

2.28 +IPR – Fixed DTE Rate

Set Command: +IPR=<rate>

Set the data rate at which the 9601 will accept commands. The change in data rate takes into effect after the result code (e.g., OK) is received by the DTE.

where:

<rate>:

- | | |
|---|---------------------|
| 1 | 600 bps |
| 2 | 1200 bps |
| 3 | 2400 bps |
| 4 | 4800 bps |
| 5 | 9600 bps |
| 6 | 19200 bps (default) |
| 7 | 38400 bps |
| 8 | 57600 bps |
| 9 | 115200 bps |

Read Command: +IPR?

Query the current data rate. The response is in the form:

+IPR:<rate>

Test Command: +IPR=?

List the supported data rates. The response is in the form:

+IPR:(supported <rate> settings)

2.29 +SBDWB – Short Burst Data: Write Binary Data to the Module

Exec Command: +SBDWB=<SBD message length>

This command is used to transfer a binary SBD message from the DTE to the single mobile originated buffer in the 9601. The mobile originated buffer can contain only one message at any one time.

- Once the command is entered, and the message length is acceptable, the 9601 will indicate to the DTE that it is prepared to receive the message by sending the ASCII encoded string "READY<CR><LF>" (hex 52 45 41 44 59 0D 0A) to the DTE.
- The <SBD message length> parameter represents the length, in bytes, of the SBD message not including the mandatory two-byte checksum.
- The maximum mobile originated SBD message length is specified at 205 bytes (and may be increased following actual performance testing). The minimum mobile originated SBD message length is 1 byte. If the <SBD message length> parameter is out of range, the 9601 issues response 3 (see below).
- Once the DTE receives the READY indication from the 9601, the SBD message must be sent from the DTE formatted as follows:
{binary SBD message} + {2-byte checksum}
 - The checksum is the least significant 2-bytes of the summation of the entire SBD message. The high order byte must be sent first. For example if the DTE were to send the word "hello" encoded in ASCII to the 9601 the binary stream would be hex 68 65 6c 6c 6f 02 14.
- The mobile originated buffer will be empty upon power-up.
- If any data is currently in the mobile originated buffer, it will be overwritten.

Command Response:

- 0 SBD message successfully written to the 9601.
- 1 SBD message write timeout. An insufficient number of bytes were transferred to 9601 during the transfer period of 60 seconds.
- 2 SBD message checksum sent from DTE does not match the checksum calculated at the 9601.
- 3 SBD message size is not correct. The maximum mobile originated SBD message length is 1960 bytes. The minimum mobile originated SBD message length is 1 byte.

2.30 +SBDRB – Short Burst Data: Read Binary Data from the Module

Exec Command: +SBDRB

This command is used to transfer a binary SBD message from the single mobile terminated buffer in the 9601 to the DTE. The mobile terminated buffer can contain only one message at any one time.

- The SBD message is transferred formatted as follows:
{2-byte message length} + {binary SBD message} + {2-byte checksum}
 - The {2-byte message length} field represents the length, in bytes, of the SBD message not including the length field or the mandatory two-byte checksum. The high order byte will be sent first.
 - The maximum mobile terminated SBD message length is length is specified at 135 bytes (and may be increased following actual performance testing).
 - The checksum is the least significant 2-bytes of the summation of the entire SBD message. The high order byte will be sent first. For example if the 9601 were to send the word “hello” encoded in ASCII to the DTE the binary stream would be hex 00 05 68 65 6c 6c 6f 02 14.
 - If there is no mobile terminated SBD message waiting to be retrieved from the 9601, the message length and checksum fields will be zero.
- The mobile terminated message buffer will be empty upon power-up.

Command Response:

There are no response codes generated by the 9601 for this command.

2.31 +SBDWT – Short Burst Data: Write a Text Message to the Module

Exec Command: +SBDWT[=<text message>]

This command is used to transfer a text SBD message from the DTE to the single mobile originated buffer in the 9601.

The text message may be entered on the command line:

- For example, “AT+SBDWT=hello”.
- The length of <text message> is limited to 120 characters. This is due to the length limit on the AT command line interface.
- The message is terminated when a carriage return is entered.

Alternatively, the text message may entered separately:

- Upon entering the command “AT+SBDWT”, the 9601 will indicate to the DTE that it is prepared to receive the message by sending the string “READY<CR><LF>” (hex 52 45 41 44 59 0D 0A) to the DTE.

- Once the DTE receives the READY indication, the text message must be sent, terminated by a carriage return.
- The length of the text message entered in this way is limited only by maximum mobile-originated SBD message length of 1960 bytes.
- The mobile originated buffer will be empty upon power-up.
- If any data is currently in the mobile originated buffer, it will be overwritten.

Command Response:

For the “AT+SBDWT” form:

- 0 SBD message successfully written to the 9601.
- 1 SBD message write timeout. An insufficient number of bytes were transferred to 9601 during the transfer period of 60 seconds.

For the “AT+SBDWT=<text message>” form:

- OK: SBD message successfully stored in mobile originated buffer.
- ERROR: An error occurred storing SBD message in mobile originated buffer.

2.32 +SBDRT – Short Burst Data: Read a Text Message from the Module

Exec Command: +SBDRT

This command is used to transfer a text SBD message from the single mobile terminated buffer in the 9601 to the DTE. This command is similar to +SBDRTB but does not provide a length indicator or checksum. The intent of this command is to provide a human friendly interface to SBD for demonstrations and application development. It is expected that most usage of SBD will be with binary messages.

- Once the command is entered, the SBD message in the mobile terminated buffer is sent out of the port.
- This command is similar to +SBDRTB except no length or checksum will be provided.
- The maximum mobile terminated SBD message length is 1890 bytes.
- The mobile terminated message buffer will be empty upon power-up.

Command Response:

+SBDRT:<CR> {mobile terminated buffer}

2.33 +SBDI – Short Burst Data: Initiate an SBD Session

Note: The +SBDI command is provided for backwards compatibility with existing FAs which do not use SBD Ring Alert functionality. For SBD calls invoked with this command:

- The SBD Session Type is fixed at type 0 – MO call.
- The SBD Delivery Short Code will be the value specified by the +SBDDSC command.
- The Detach/Attach flag is fixed at the Detach setting.
- The Location Update flag is fixed at the No Update setting.

FAs requiring SBD Ring Alert functionality should use the extended +SBDIX command.

Exec Command: +SBDI

This command initiates an SBD session between the 9601 and the GSS. If there is a message in the mobile originated buffer it will be transferred to the GSS. Similarly if there is one or more messages queued at the GSS the oldest will be transferred to the 9601 and placed into the mobile terminated buffer.

- The message, if any, in the mobile originated buffer will be sent from the 9601 to the GSS.
- If there is a message queued at the GSS it will be transferred to the 9601 and placed into the mobile terminated buffer.

Command Response:

+SBDI:<MO status>,<MOMSN>,<MT status>,<MTMSN>,<MT length>,<MT queued>

where:

<MO status>:

MO session status provides an indication of the disposition of the mobile originated transaction. The field can take on the following values:

- 0 No SBD message to send from the 9601.
- 1 SBD message successfully sent from the 9601 to the GSS.
- 2 An error occurred while attempting to send SBD message from 9601 to GSS.

<MOMSN>:

The Mobile Originated Message Sequence Number (MOMSN) is a value assigned by the 9601 when sending a mobile-originated message to the GSS. This value is

incremented each time an SBD session is successfully completed between the 9601 to the GSS. This wrap around counter can range from 0 to 65535.

<MT status>:

The MT status provides an indication of the disposition of the mobile terminated transaction. The field can take on the following values:

- 0 No SBD message to receive from the GSS.
- 1 SBD message successfully received from the GSS.
- 2 An error occurred while attempting to perform a mailbox check or receive a message from the GSS.

<MTMSN>:

The Mobile Terminated Message Sequence Number (MTMSN) is assigned by the GSS when forwarding a message to the 9601. This value is indeterminate if the field <MT status> is zero. This wrap around counter can range from 0 to 65535.

<MT length>:

The MT length is the length in bytes of the mobile terminated SBD message received from the GSS. If no message was received, this field will be zero.

<MT queued>:

MT queued is a count of mobile terminated SBD messages waiting at the GSS to be transferred to the 9601.

2.34 +SBDDDET – Short Burst Data: Detach (*new*)

Exec Command: +SBDDDET

Initiates an SBD session to detach the Transceiver from the Gateway.

Command Response:

+SBDDDET:<status>,<error>

where:

<status>:

- 0 Detach successfully performed
- 1 An error occurred while attempting the detach

<error>:

Gateway-reported values

- 0 No error.

- 1..4 Reserved, but indicate success if used.
- 5..14 Reserved, but indicate failure if used.
- 15 Access is denied.

Transceiver-reported values

- 16 Transceiver has been locked and may not make SBD calls (see +CULK command).
- 17 Gateway not responding (local session timeout).
- 18 Connection lost (RF drop).
- 19..31 Reserved, but indicate failure if used.
- 32 No network service, unable to initiate call.
- 33 Antenna fault, unable to initiate call.
- 34 Radio is disabled, unable to initiate call (see *Rn command).
- 35 Transceiver is busy, unable to initiate call (typically performing auto-registration).
- 36.. Reserved, but indicate failure if used.

This instructs the Gateway to disable (detach) SBD ring alerts for the calling Transceiver. Successful completion of the detach command implies that the Gateway has performed the requested detach action and the Transceiver is no longer registered. This session does not transfer any MO or MT messages.

Note: A user can send an MO-SBD message and request a detach at the same time by using the +SBDI command. The +SBDI command always requests a detach.

2.35 +SBDDSC – Short Burst Data: Delivery Short Code

Set Command: +SBDDSC=<dsc>

Set the Delivery Short Code (DSC), which provides dynamic routing information for uploaded messages. This is an 8-bit value providing the ability to set individual fields. Value 0x80 (hexadecimal) sets the most significant bit. Value 0x01 sets the least significant bit. Flag values can be added together to achieve a combination of settings. Some fields may be “locked” when the Transceiver is in a special mode (e.g. Autoregistration locks the flag values 0x80 and 0x40).

<dsc>:

- 0..255 DSC to be used for subsequent uploaded messages (0 default)
- 0x80 Hold MT message delivery

0x40 Leave MT message in queue after delivery

0x20 Destination in MO payload

Read Command: +SBDDSC?

Query the current Delivery Short Code. The response is of the form:

+SBDDSC:<dsc>

2.36 +SBDIX – Short Burst Data: Initiate an SBD Session Extended (new)

Note: The +SBDIX command must be used in place of the +SBDI command for FAs wishing to make use of SBD Ring Alert functionality.

Exec Command: +SBDIX[A][=<location>]

This command initiates an SBD session between the 9601 and the GSS, setting the SBD Session Type according to the type of command +SBDIX or +SBDIXA, Delivery Short Code according to the value specified by the +SBDDSC command, and the type of location according to whether the optional location value is provided. If there is a message in the mobile originated buffer it will be transferred to the GSS. Similarly if there is one or more messages queued at the GSS the oldest will be transferred to the 9601 and placed into the mobile terminated buffer.

- The message, if any, in the mobile originated buffer will be sent from the 9601 to the GSS.
- If there is a message queued at the GSS it will be transferred to the 9601 and placed into the mobile terminated buffer.
- This command will always attempt an SBD registration, consisting of attach and location update, during the SBD session in order to support SBD Ring Alert. If this is not desired, the +SBDI command should be used.
- The FA should append an 'A' to the command, i.e. +SBDIXA, when the SBD session is in response to a ring alert.

<location> has format:

[+|-]DDMM.MMM,[+|-]dddmm.mmm

where:

DD Degrees latitude (00-89)

MM Minutes latitude (00-59)

MMM Thousandths of minutes latitude (000-999)

ddd Degrees longitude (000-179)

mm Minutes longitude (00-59)

mmm Thousandths of minutes longitude (000-999)

The optional sign indicators specify latitude North (+) or South (-), and longitude East (+) or West (-). If omitted, the default is +.

For example,

```
AT+SBDIX=5212.483,-00007.350
```

corresponds to 52 degrees 12.483 minutes North, 0 degrees 7.35 minutes West.

Command Response:

```
+SBDIX:<MO status>,<MOMSN>,<MT status>,<MTMSN>,<MT length>,<MT queued>
```

where:

<MO status>:

MO session status provides an indication of the disposition of the mobile originated transaction. The field can take on the following values:

Gateway-reported values

- 0 MO message, if any, transferred successfully.
- 1 MO message, if any, transferred successfully, but the MT message in the queue was too big to be transferred.
- 2 MO message, if any, transferred successfully, but the requested Location Update was not accepted.
- 3..4 Reserved, but indicate MO session success if used.
- 5..8 Reserved, but indicate MO session failure if used.
- 10 Gateway reported that the call did not complete in the allowed time.
- 11 MO message queue at the Gateway is full.
- 12 MO message has too many segments.
- 13 Gateway reported that the session did not complete.
- 14 Invalid segment size.
- 15 Access is denied.

Transceiver-reported values

- 16 Transceiver has been locked and may not make SBD calls (see +CULK command).
- 17 Gateway not responding (local session timeout).
- 18 Connection lost (RF drop).
- 19..31 Reserved, but indicate MO session failure if used.

- 32 No network service, unable to initiate call.
- 33 Antenna fault, unable to initiate call.
- 34 Radio is disabled, unable to initiate call (see *Rn command).
- 35 Transceiver is busy, unable to initiate call (typically performing auto-registration).
- 36.. Reserved, but indicate failure if used.

<MOMSN>:

The Mobile Originated Message Sequence Number (MOMSN) is a value assigned by the 9601 when sending a mobile-originated message to the GSS. This value is incremented each time an SBD session is successfully completed between the 9601 to the GSS. This wrap around counter can range from 0 to 65535.

<MT status>:

The MT status provides an indication of the disposition of the mobile terminated transaction. The field can take on the following values:

- 0 No MT SBD message to receive from the Gateway.
- 1 MT SBD message successfully received from the Gateway.
- 2 An error occurred while attempting to perform a mailbox check or receive a message from the Gateway.

<MTMSN>:

The Mobile Terminated Message Sequence Number (MTMSN) is assigned by the GSS when forwarding a message to the 9601. This value is indeterminate if the field <MT status> is zero. This wrap around counter can range from 0 to 65535.

<MT length>:

The MT length is the length in bytes of the mobile terminated SBD message received from the GSS. If no message was received, this field will be zero.

<MT queued>:

MT queued is a count of mobile terminated SBD messages waiting at the GSS to be transferred to the 9601.

2.37 +SBDMTA – Short Burst Data: Mobile-Terminated Alert (*new*)

Set Command: +SBDMTA=<mode>

Enable or disable ring indications for SBD Ring Alerts.

<mode>:

- 0 Disable ring indication
- 1 Enable ring indication (default)

When ring indication is enabled, the 9601 asserts the RI line and issues the unsolicited result code SBDRING when an SBD ring alert is received.

Read Command: +SBDMTA?

Query the current ring indication mode. The response is of the form:

+SBDMTA:<mode>

Test Command: +SBDMTA=?

List the supported mode settings. The response is of the form:

+SBDMTA:(supported <mode> settings)

2.38 +SBDREG – Short Burst Data: Network Registration (*new*)

Exec Command: +SBDREG[=<location>]

Triggers an SBD session to perform a manual SBD registration.

This command initiates an SBD session to perform a manual SBD registration, consisting of an attach and location update. The session type will be set to 2 – registration. This session does not transfer any MO or MT messages.

Note: The Transceiver restricts the number of manual and automatic registrations to one every 3 minutes. Successive attempts within 3 minutes will return an error code indicating that the FA should try later (see error 36 below).

Note: A user can send an MO SBD message and register at the same time by using the +SBDIX command. The +SBDIX command always performs a registration attempt and should be used for an application requiring SBD Ring Alert. The +SBDI command never includes an SBD registration and should be used for an application that does not require SBD Ring Alert.

<location> has format:

[+|-]DDMM.MMM,[+|-]dddmm.mmm

where:

- DD Degrees latitude (00-89)
- MM Minutes latitude (00-59)
- MMM Thousandths of minutes latitude (000-999)
- ddd Degrees longitude (000-179)
- mm Minutes longitude (00-59)

mmm Thousandths of minutes longitude (000-999)

The optional sign indicators specify latitude North (+) or South (-), and longitude East (+) or West (-). If omitted, the default is +.

For example,

AT+SBDIX=5212.483,-00007.350

corresponds to 52 degrees 12.483 minutes North, 0 degrees 7.35 minutes West.

Command Response:

+SBDREG:<status>,<reg err>

where:

<status> indicates the resulting registration status of the Transceiver:

- 0 Detached – Transceiver is detached as a result of a successful +SBDDDET or +SBDI command.
- 1 Not registered – Transceiver is attached but has not provided a good location since it was last detached.
- 2 Registered – Transceiver is attached with a good location. Note that this may be the case even when the most recent attempt did not provide a good location.
- 3 Registration denied – The gateway is denying service to the Transceiver.
- 4 Unknown

<reg err>:

Gateway-reported values

- 0 No error.
- 2 Session completed but the requested Location Update was not accepted.
- 3..14 Reserved, but indicate Location Update failure if used.
- 15 Access is denied.

Transceiver-reported values

- 16 Transceiver has been locked and may not make SBD calls (see +CULK command).
- 17 Gateway not responding (local session timeout).
- 18 Connection lost (RF drop).

- 19..31 Reserved, but indicate failure if used.
- 32 No network service, unable to initiate call.
- 33 Antenna fault, unable to initiate call.
- 34 Radio is disabled, unable to initiate call (see *Rn command).
- 35 Transceiver is busy, unable to initiate call (typically performing auto-registration).
- 36 Try later, must wait 3 minutes since last registration.
- 37.. Reserved, but indicate failure if used.

Read Command: +SBDREG?

Query the current SBD registration status of the Transceiver. The response is of the form:

```
+SBDREG:<status>
<status>:
0 Detached
1 Not registered
2 Registered
3 Registration denied
4 Unknown
```

The registration status is stored in Transceiver non-volatile memory, and can therefore be queried by the FA after powering up.

2.39 +SBDAREG – Short Burst Data: Automatic Registration (*new*)

Set Command: +SBDAREG=<mode>

Set the Transceiver's Auto-registration mode.

```
<mode>:
0 Disable automatic registration (default)
1 Set the Auto-registration mode to "Automatic"
2 Set the Auto-registration mode to "Ask"
```

When auto-registration is enabled, mode 1 or 2, the Transceiver monitors its current location and triggers an auto-registration when it determines that the Transceiver has moved sufficiently far away from its last registered location. Note

that auto-registration runs only while the Transceiver is attached to the gateway, i.e. the registration status is “Not registered” or “Registered”.

Auto-registration may only be used with system-provided location. If the FA is providing its own location (e.g. GPS), the FA should use the manual registration command, +SBDREG.

Upon triggering in mode 1, “Automatic”, the Transceiver autonomously initiates an SBD session in order to perform a registration with the updated location of the Transceiver, with the session type set to 3 – auto-registration. This session does not transfer any MO or MT messages.

Upon triggering in mode 2, “Ask”, the Transceiver reports to the FA that it should register with the system because the Transceiver location has changed (see <event> below); it is then the responsibility of the FA to register via +SBDREG or +SBDIX. +SBDIX allows the FA to register while including an MO message and/or retrieving an MT message that is pending at the Gateway.

When auto-registration is enabled, mode 1 or 2, the Transceiver reports relevant events to the FA by issuing an unsolicited result code +AREG:<event>,<reg error>.

<event>:

- 0 Suggest FA makes a registration attempt (mode 2 only)
- 1 Auto-registration has been performed successfully (mode 1 only)
- 2 Auto-registration has failed and will be retried after a delay (mode 1 only)

<reg error>:

Gateway-reported values

- 0 No error.
- 2 Session completed but the requested Location Update was not accepted.
- 3..14 Reserved, but indicate Location Update failure if used.
- 15 Access is denied.

Transceiver-reported values

- 16 Transceiver has been locked and may not make SBD calls (see +CULK command).
- 17 Gateway not responding (local session timeout).
- 18 Connection lost (RF drop).
- 19..31 Reserved, but indicate failure if used.

- 32 No network service, unable to initiate call.
- 33 Antenna fault, unable to initiate call.
- 34 Radio is disabled, unable to initiate call (see *Rn command).
- 35 Transceiver is busy, unable to initiate call (typically performing auto-registration).
- 36 Try later, must wait 3 minutes since last registration.
- 37.. Reserved, but indicate failure if used.

Read Command: +SBDAREG?

Query the current automatic MT registration mode. The response is of the form:

+SBDAREG:<mode>

Test Command: +SBDAREG=?

List the supported mode settings. The response is of the form:

+SBDAREG:(supported <mode> settings)

2.40 +SBDD – Short Burst Data: Clear SBD Message Buffer(s)

Exec Command: +SBDD<Delete type>

This command is used to clear the mobile originated buffer, mobile terminated buffer or both.

- The <Delete type> parameter identifies which buffers are cleared.
 - 0 Clear the mobile originated buffer.
 - 1 Clear the mobile terminated buffer.
 - 2 Clear both the mobile originated and mobile terminated buffers.
- Using this command or power cycling the 9601 are the only means by which both buffers are cleared.
- The mobile terminated buffer will be cleared when an SBD session is initiated.
- Sending a message from the 9601 to the ESS does not clear the mobile originated buffer.
- Reading a message from the 9601 does not clear the mobile terminated buffer.

Command Response:

- 0 Buffer(s) cleared successfully.
- 1 An error occurred while clearing the buffer(s).

2.41 +SBDC – Short Burst Data: Clear SBD MOMSN

Exec Command: +SBDC

This command will clear (set to 0) the mobile originated message sequence number (MOMSN) stored in the 9601.

- The MOMSN is maintained even after power cycle.

Command Response:

- 0 The MOMSN was cleared successfully.
- 1 An error occurred while clearing the MOMSN.

2.42 +SBDS – Short Burst Data: Status

Exec Command: +SBDS

This command returns current state of the mobile originated and mobile terminated buffers.

Command Response:

+SBDS:<MO flag>,<MOMSN>,<MT flag>,<MTMSN>

where:

<MO flag>:

The MO flag indicates the existence of a message in the mobile originated buffer. The response from the 9601 is one of the following numeric codes:

- 0 No message in mobile originated buffer
- 1 Message in mobile originated buffer

<MOMSN>:

The MOMSN identifies the sequence number that will be used during the next mobile originated SBD session.

<MT Flag>:

The MT flag indicates the existence of a message in the mobile terminated buffer. The response from the 9601 is one of the following numeric codes:

- 0 No message in mobile terminated buffer
- 1 Message in mobile terminated buffer

<MTMSN>:

The MTMSN identifies the sequence number that was used in the most recent mobile terminated SBD session. This value will be -1 if there is nothing in the mobile terminated buffer.

2.43 +SBDTC – Short Burst Data: Transfer MO Buffer to MT Buffer

Exec Command: +SBDTC

This command will transfer the contents of the mobile originated buffer to the mobile terminated buffer. Developers of DTE can use this command to test reading and writing to the 9601 without actually initiating SBD sessions with the ESS.

Command Response:

The command produces a response of the form “SBDTC: Outbound SBD copied to Inbound SBD: size = <size>” followed by “OK”, where:

<size>:

The length of the message in bytes.

2.44 -MSSTM – Request System Time

Exec Command: -MSSTM

Query the latest system time received from the network. The response is the form:

-MSSTM:<system_time>

<system_time> can take one of the following forms:

no network service The 9601 has not yet received system time from the network.

XXXXXXXX Where XXXXXXXX is the current Iridium system time available from the network. The system time as received through the Iridium Air Interface, is a 32 bit integer count of the number of 90 millisecond intervals that have elapsed since the epoch. The return value is formatted as an ASCII hexadecimal number. The counter will rollover approximately every 12 years.

Iridium system time epoch: June 1, 1996, 00:00:13 (GMT):

Iridium system time source: The system time is available and valid only after the 9601 has registered with the network and has received the Iridium system time from the network. Once the time is received, the 9601 uses its internal clock to increment the counter. In addition, at least every 8 hours, or on location update or other event that requires re-registration, the 9601 will obtain a new system time from the network.

Time localization: None. The system time value is always expressed in GMT time.

Resolution and accuracy: The resolution of the system time is one Iridium frame tick, or 90 ms. Accuracy as measured by the difference between the time reported and the actual time it is sent out the 9601 serial port should not exceed 4 frame ticks (.36 seconds) and in most cases will be one frame tick (.09 seconds) or less.

3 S-Register Definitions

S-registers allow control over specific 9601 operations. Some S-registers contain a single numeric value, other S-registers are bit-mapped where individual bits, or set of bits, control specific functions.

Table 1 defines the S-registers used for 9601 Transceiver. Many of the 9522A Transceiver S-registers are obsolete for 9601 Transceiver, and 9601 Transceiver requires some new S-registers. To prevent reallocation of obsolete S-registers, they are reserved and shaded out in the table, and the new S-registers are registers that are unused in 9522A Transceiver and are marked as “*new for 9601 Transceiver*”.

All S-registers, from S0 to S127, are readable. All write permissions remain unchanged from 9522A Transceiver, even where a writable register is not used in 9601 Transceiver. Writable registers are highlighted in the “Sr=n writable?” column. An FA *could* use the unused writable S-registers to store application-specific data.

The final column in the table indicates which S-registers are stored in non-volatile memory as part of a user profile; the 9601 can be reset to a stored profile using the Zn command.

3.1 S-Register Commands

Commands allow S-registers to be read, written, or simply referenced (i.e. set a pointer to designate the current, referenced S-register). S-register commands are described in the following subsections.

3.1.1 Sr – Direct S-Register Reference

Set a pointer to reference S-register r.

3.1.2 Sr? – Direct S-Register Read

Read the value of S-register r.

3.1.3 Sr=n – Direct S-Register Write

Set the value of S-register r to n, where n is a decimal value in the range 0 to 255.

3.1.4 ? – Referenced S-Register Read

Read the value of the current referenced S-register. The current referenced S-register is that which was last acted upon by a direct reference (ATSr), read (ATSr?), or write (ATSr=n) command.

3.1.5 =n – Referenced S-Register Write

Set the value of the current referenced S-register to n. The current referenced S-register is that which was last acted upon by a direct reference (ATSr), read (ATSr?), or write (ATSr=n) command.

3.2 S-Registers

Table 1: 9601 Transceiver S-Registers

Register	Range	Default	Description	Sr=n writable?	Profile Setting?
S0	0-255	0	Autoanswer. Assigning a value from 1 to 255 in register S0 tells the ISU to automatically answer incoming calls. The factory setting of 0 turns off the automatic answer feature.	✓	✓
S1	0-255	0	Ring count		✓
S2	0-255	43	Escape code character	✓	✓
S3	0-127	13	Carriage return character	✓	
S4	0-127	10	Line feed character	✓	
S5	0-32	8	Backspace character	✓	
S6	0-255	4	Wait for dial-tone.	✓	✓
S7	0-255	50	Communication standard used by ISU	✓	✓
S8	0-255	4	Pause time for comma.	✓	✓
S9	0-255	6	Carrier detect response time.	✓	✓
S10	0-255	14	Carrier loss time.	✓	✓
S11	0-255	0	DTMF tone duration.		✓
S12	0-255	50	Escape guard time. Time, in 50ths of a second, until OK displayed after entering command mode by escape sequence	✓	✓

Register	Range	Default	Description	Sr=n writable?	Profile Setting?
S13	0-255	49	Bitmap register: bits 0-1: DCE data bits bits 2-3: DCE stop bits bits 4-6: DCE parity setting		✓
S14	0-255	170	Bitmap register: bit 1: En setting (echo) bit 2: Qn setting (quiet) bit 3: Vn setting (verbose) bit 5: Pulse/tone dial mode	✓	✓
S21	0-255	48	Bitmap register: bit 0: Telephone jack control bit 2: RTS/CTS on/off bits 3-4: &Dn setting (DTR operation) bit 5: &Cn setting bit 6: Disconnecting long space		✓
S22	0-255	246	Bitmap register: bits 0-1: speaker volume setting bits 2-3: speaker on/off setting bits 4-6: Xn setting		✓
S23	0-255	61	Bitmap register: bits 1-4: +IPR setting (DTE baud rate) bits 6-7: guard tone		✓
S25	0-255	5	Sets length of time in hundredths of a second that a change in the DTR status has to persist for before it is recognized.	✓	✓
S27	0-255	9	Bitmap register: bits 0-2: &Qn setting bit 3: leased line operation setting bits 4-5: synchronous clock setting		✓
S28	0-255	0	Bitmap register: bits 3-4: &Pn setting (pulse dial make/break ratio)		

Register	Range	Default	Description	Sr=n writable?	Profile Setting?
S30	0-255	0	Disconnect activity timer. Timer used to determine how long the call connection been inactive, in increments of 1/10000ms. A value of 0 disables this function.	✓	✓
S31	0-255	0	Bitmap register: bit 1: line modulation method setting bits 2-3: Wn setting		✓
S34	0-255	0	Bitmap register: bits 0-1: data compression type (PT) bit 6: +DS compression negotiation setting bit 7: +DR setting		✓
S35	0-255	7	Bearer service capabilities	✓	✓
S36	0-255	0	Bitmap register: bits 0-2: link type setting		
S37	0-255	0	Bitmap register: bits 0-4: Fn setting (line modulation standard)	✓	
S39	0-255	3	Bitmap register: bits 0-2: &Kn setting (flow control)		✓
S40	0-255	104	Bitmap register: bits 2-4: \K setting bits 3-5: \Kn setting bits 6-7: \An setting		✓
S41	0-255	0	Bitmap registers: bits 2, 6: enable retrain on bad signal quality setting bit 4: xon/xoff usage setting bit 5: DTE auto rate adjustment setting		

Register	Range	Default	Description	Sr=n writable?	Profile Setting?
S42	0-255	16	GSM Call clearing code as returned by the network. Refer to GSM 04.08 Table 10.86 Cause Information Element Values.		✓
S43	0-255	32	Bitmap register: bit 0: +CMGF setting bit 1: +CBST parameter <name> setting bit 2: +CMEE setting bit 3: +CMEE setting bit 5: +CBST parameter <ce> setting bit 6: +CRC setting bit 7: +CR setting		✓
S44	0-255	4	Bitmap register: bits 0-2: +CPBS setting bits 5-6: +CREG setting bit 7: reserved		
S45	0-255	0	Bitmap register: bits 0-1: +CNMI parameter <mode> setting bits 2-3: +CNMI parameter <mt> setting bits 4-5: +CNMI parameter <bm> setting bits 6-7: +CNMI parameter <ds> setting		
S47	0-255	0	Bitmap register: bits 4-6: TON settings for dial string	✓	✓
S49	0-255	1	Bitmap register: bits 0-3: NPI settings for dial string	✓	✓
S51	0-255	2	V.42bis maximum codewords (P1), high byte		✓
S52	0-255	0	V.42bis maximum codewords (P1), low byte	✓	✓
S54	0-255	6	V.42bis maximum string size (P2)	✓	✓

Register	Range	Default	Description	Sr=n writable?	Profile Setting?
S58	0-255	3	V.42 bis compression direction (P0)	✓	✓
S95	0-255	0	Bitmap register for extended result codes (overrides Wn setting): bit 0: CONNECT shows DCE speed bit 2: Enable CARRIER XXXX bit 3: Enable PROTOCOL: XXXX bit 5: Enable COMPRESSION: XXXX	✓	✓
S96	0-255	0	IRLP version number (N0) parameter	✓	
S98	1-105	105	IRLP k iwf->isu parameter	✓	
S99	1-105	105	IRLP k isu->iwf parameter	✓	
S10 0	1-15	15	IRLP N2 parameter	✓	
S10 2	26-255	30	IRLP T1 parameter	✓	
S10 3	10-255	10	IRLP T2 parameter	✓	
S10 4	4-255	25	IRLP T4 parameter	✓	
S10 6	1-10	10	IRLP riwf->isu parameter	✓	
S10 7	1-10	10	IRLP risu->iwf parameter	✓	
S11 0	0-1	0	SBM max segment size (40-310) (high byte)		
S11 1	0-255	135	SBM max segment size (40-310) (low byte)		
S11 2	0-255	0	SBD upload message sequence number (high byte)		

Register	Range	Default	Description	Sr=n writable?	Profile Setting?
S11 3	0-255	0	SBD upload message sequence number (low byte)		
S12 1	0-15	1	New for 9601 Transceiver Bitmap register: bit 0: +SBDMTA setting (ring indication) bit 1-2: +SBDAREG setting (automatic registration)		✓
S12 2	0-31	1	New for 9601 Transceiver Bitmap register: bit 0: *R setting (radio activity) bits 1-4: +CIER setting (indicator event reporting)		✓
S12 3	0-255	8	Bitmap register: bit 1: +WTM bit 2: +WDLDM<dldm> bit 3: +WIRLP<mode> bits 4-5: +WFRNG		
S12 4	0-255	15	Dynamic link measurement interval (+WDLM <mi> setting). Value in 1000 ms unit	✓	
S12 5	1-100	10	Dynamic link delay measurement delay tolerance (+WDLM<dtl> setting). Value in % unit	✓	

Register	Range	Default	Description	Sr=n writable?	Profile Setting?
S12 6	0-255	2	Bitmap register: bit 0: Ignore &Dn command specified reaction to DTR ON to OFF transitions. Disconnect as reaction to Hn command. OK response given bit 1: Ignore &Dn command specified reaction to DTR ON to OFF transitions. Ignore Hn command. OK response given bit 2: Comply with &Dn command specified reaction to DTR ON to OFF transitions. Disconnect as reaction to Hn command.		
S12 7	0-255	0	Bitmap Register containing copies of MSVTR/MSVLS parameters: Bit 0: -MSVTR: 0 = Disabled (default) 1 = Enabled Bit 1: -MSVLS: 0 = No Mute (default) 1 = Mute Enabled		✓

4 Summary of Result Codes

Table 2: Result codes

Numeric (v0)	Verbose (v1)	Description
0	'OK'	Acknowledges execution of command
2	'SBDRING'	MT messages present at gateway (unsolicited if enabled). See section 2.34
4	'ERROR'	Command not accepted
127	'HARDWARE FAILURE: <subsys>,<error>'	Issued at initialisation in case of a hardware failure.
as verbose	'READY'	Ready to receive binary message data from DTE
as verbose	'+AREG: <event>,<reg error>'	Auto-registration event report. See section 2.39
as verbose	'+CIEV: <sig>,<value>'	Indicator event report (unsolicited if enabled). See section 2.21

5 Informative Examples

5.1 Setting the Default Configuration

The FA sets the Transceiver’s default configuration to no handshaking, no flow control, radio enabled, SBD ring alerts enabled.

To Transceiver (from FA)	To FA (from Transceiver)	Description
AT&K0		Disable RTS/CTS flow control
	OK	
AT*R1		Enable the radio
	OK	
AT+SBDMTA=1		Enable SBD ring indications
	OK	
AT&W0		Store the configuration as profile 0
	OK	
AT&Y0		Select profile 0 as the power-up default
	OK	

5.2 Power-on to Sending a Message

The FA will power up the Transceiver, wait for the Transceiver to acquire the network, and send a 70-byte message.

To Transceiver (from FA)	To FA (from Transceiver)	Description
		Apply power to the 9601
		Wait for DSR to become asserted
AT+CIER=1,0,1,0		Enable service indication reporting (note that this can be stored in the default configuration)
	OK	
	+CIEV: 1,1	Wait for the 9601 to acquire the network
AT+SBDWB=70		Transfer message to 9601
	READY	
<binary transfer>		
	0	
AT+SBDIX		Perform SBD session
	+SBDIX: 0,23,0,-1,0,0	
AT+SBDD0		Clear the MO message buffer
	OK	

5.3 Ring Alert Registration

The FA verifies its registration state, performs a registration in order to be able to receive ring alerts, and enables ring alert indications.

To Transceiver (from FA)	To FA (from Transceiver)	Description
AT+SBDREG?		Query the Transceiver registration status
	+SBDREG:0	Transceiver is detached, i.e. un-registered
AT+SBDREG		Tell the Transceiver to register for ring alerts
	+SBDREG:2,0	Transceiver is now registered
AT+SBDREG?		Query the Transceiver registration status
	+SBDREG:2	Transceiver is registered
AT+SBDMTA=1		Enable SBD ring indications from Transceiver to FA
	OK	

5.4 Ring Alert Message Reception

The FA verifies its registration state. Upon receiving a ring alert the FA initiates an SBD session to receive an MT message.

To Transceiver (from FA)	To FA (from Transceiver)	Description
AT+SBDREG?		Query the Transceiver registration status
	+SBDREG:2	Transceiver is registered
	...	Vendor application sends an MT message to the GSS
	+SBDRING	Transceiver indicates an incoming message. The RI line also toggles.
AT+SBDIXA		FA initiates an SBD session in answer to the ring alert
	+SBDIXA:0,23,1,237,90,2	Transceiver informs FA that a 90-byte message was successfully received with MTMSN 237, and that two further MT messages are queued at the GSS
AT+SBDRB		FA retrieves the received message from the Transceiver
	<binary transfer>	

5.5 Ring Alert Automatic Registration

The FA verifies its registration state and enables automatic registration using the “Ask” mode.

To Transceiver (from FA)	To FA (from Transceiver)	Description
AT+SBDREG?		Query the Transceiver registration status
	+SBDREG:2	Transceiver is registered
AT+SBDAREG=2		FA sets the automatic registration to “Ask” mode
	OK	
	...	Transceiver is moved
	+AREG:0,0	Transceiver notifies FA that it needs to register
AT+SBDREG		FA instructs the Transceiver to register
	+SBDREG:2,0	Registration is successful

5.6 Sending a Message with Minimal Radio Activity

Assuming that service indication events have been turned on with AT+CIEV=1,0,1, and the radio has been disabled with AT*R0.

To Transceiver (from FA)	To FA (from Transceiver)	Description
AT+SBDWB=70		Transfer message to 9601
	READY	
<binary transfer>		
	0	
AT*R1		Activate the radio and wait for the Transceiver to acquire the network
	OK	
	+CIEV:1,1	Transceiver has acquired the network
AT+SBDI		Perform SBD session
	+SBDI: 0,23,0,-1,0,0	
AT*R0		Deactivate the radio
	OK	
AT+SBDD0		Clear the MO message buffer
	OK	

5.7 Powering Down

The FA flushes any pending Eeprom writes before powering down the Transceiver.

To Transceiver (from FA)	To FA (from Transceiver)	Description
AT*F		FA tells Transceiver to flush pending writes to Eeprom and waits for completion
	OK	
<binary transfer>		FA may now safely disconnect the Transceiver power supply.

6 Table of AT Command Changes

Table 3 shows which 9522A Transceiver AT commands are modified or removed, and which AT commands are new for 9601 Transceiver. Removed commands are shaded.

Table 3: Changes to AT commands

Command	Description	Modified	New
AT	Attention code		
A/	Repeat last command		
+++	Escape sequence		
A	Answer		
Bn	Communication standards		
Cn	Carrier control		
D	Dial		
En	Echo		
Fn	Line modulation		
Hn	Hangup		
In	Identification		
Ln	Loudspeaker volume		
Mn	Speaker control		
Nn	Automode enable		
On	Online		
P	Pulse dial		
Qn	Quiet mode		
T	Tone dial		
Vn	Verbose mode		
Wn	Error correction message control		

Command	Description	Modified	New
Xn	Extended result codes		
Yn	Long space disconnect		
Zn	Soft reset		
&Cn	DCD option		
&Dn	DTR option	✓	
&Fn	Restore factory settings		
&Gn	Guard tone		
&Jn	Jack control		
&Kn	Flow control	✓	
&Ln	Leased line operation		
&Mn	Asynchronous/synchronous mode		
&Pn	Pulse dial make/break ratio		
&Qn	Sync/async mode		
&Rn	RTS/CTS option		
&Sn	DSR override		
&V	View active and stored configuration		
&Wn	Store active configuration		
&Xn	Select asynchronous clock		
&Yn	Designate default reset profile		
\An	MNP block size		
\Bn	Transmit break		
\Gn	XON/XOFF flow control		
\Jn	DTE auto rate		
\Kn	Control break		
\Nn	Link type		

Iridium Satellite LLC
9601 Transceiver – AT Command Reference

Command	Description	Modified	New
%Cn	Compression control		
%En	Auto retrain		
%R	Display registers		
*F	Flush to eeprom		✓
*Pn	Power phone		
*Rn	Radio activity		✓
+CBC	Battery charge		
+CBST	Select bearer service type		
+CCFC	Call forward service		
+CCLK	Real-time clock		
+CEER	Extended error report		
+CGMI	Manufacturer identification		
+CGMM	Model identification		
+CGMR	Revision		
+CGSN	Serial number		
+CHUP	Hangup call		
+CIER	Indicator event reporting		✓
+CLCC	Request current call status		
+CLCK	Facility lock		
+CLVL	Loudspeaker volume level control		
+CMEE	Report mobile equipment error		
+CMGD	Delete SMS message		
+CMGF	SMS message format		
+CMGL	List SMS messages		
+CMGR	Read SMS message		

Iridium Satellite LLC
9601 Transceiver – AT Command Reference

Command	Description	Modified	New
+CMGS	Send SMS message		
+CMGW	Write SMS message to memory		
+CMOD	Call mode		
+CMUT	Mute control		
+CNMI	New SMS message indications to DTE		
+CNUM	Read MSISDN numbers		
+COPS	Operator select		
+CPAS	Phone activity status		
+CPBF	Find phonebook entries		
+CPBR	Read phonebook entries		
+CPBS	Select phonebook storage		
+CPBW	Write phonebook entry		
+CPIN	Enter PIN		
+CPMS	Select preferred SMS message storage		
+CPWD	Change password		
+CR	Service reporting control		
+CRC	Cellular result codes		
+CREG	Network registration		
+CSCA	SMS service center address		
+CSCB	Select cell broadcast message types		
+CSCS	Select TE character set		
+CSMS	Select SMS message service		
+CSQ	Signal quality		
+CSTA	Select type of address		
+CULK	Unlock		✓

Command	Description	Modified	New
+CVHU	Voice hangup control		
+DR	Data compression report level		
+DS	Set data compression function		
+GCAP	General capabilities		
+GMI	Manufacture identification		
+GMM	Model identification		
+GMR	Revision		
+GSN	Serial number		
+IPR	Fixed DTE rate		
+SBDAREG	Short burst data: Automatic registration		✓
+SBDC	Short burst data: Clear SBD MOMSN		
+SBDD	Short burst data: Clear SBD message buffers		
+SBDDDET	Short burst data: Detach		✓
+SBDDSC	Short burst data: Delivery short code		
+SBDI	Short burst data: Initiate an SBD session		
+SBDIX	Short burst data: Initiate an SBD session extended		✓
+SBDIXA	Short burst data: Initiate an SBD session extended		✓
+SBDMTA	Short burst data: Mobile-terminated alert		✓
+SBDARB	Short burst data: Read binary data from ISU		
+SBDREG	Short burst data: Automatic registration		✓
+SBDRT	Short burst data: Read a text message from the ISU		
+SBDS	Short burst data: Status		
+SBDTC	Short burst data: Transfer MO buffer to MT buffer		

Command	Description	Modified	New
+SBDWB	Short burst data: Write binary data to the ISU		
+SBDWT	Short burst data: Write a text message to the ISU		
+SBDZ	Short burst data: Segment size		
+WDAV	Register or deregister an RS232 DAV data peripheral		
+WDLDM	IRLP dynamic link delay measurement		
+WFRNG	Force IRLP renegotiation		
+WIRLP	Iridium radio link protocol		
+WTM	IRLP test mode		
-MSGEO	Request geolocation		
-MSSTM	Request system time		
-MSVLS	Local DTMF feedback selection		
-MSVTR	DTMF received in voice call		
-MSVTS	DTMF generation in voice call		