



Ecom Sertech Corp.

Rm. 258, Bldg. 17, NO.195, Sec. 4 Chung Hsing Rd., ChuTung Chen, Hsinchu, Taiwan 310, R.O.C
TEL:886-3-5918012 FAX: 886-3-5825720

FCC ID : Q5SWM68-1

Report No. : ER04-05-058FRF

Page 1 of 57



TEST REPORT

Product Name : 54Mbps 802.11g Wireless LAN MiniPCI Card

Model Number : WM68

FCC ID : Q5SWM68-1

Applicant : Fi Win, Inc.

Address : 8F, No. 10, Prosperity Rd., Science-Based
Industrial Park, Hsin Chu, Taiwan 300.

Received Date : May 20, 2004

Tested Date : May 20 ~ 31, 2004

Notes :

1. This report will be invalid if duplicated or photocopied in part.
2. This report refers only to the specimen(s) submitted to testing, and be invalid as separately used.
3. This report is invalid without examination stamp and signature of this institute.
4. The tested specimen(s) will be preserved for thirty days from the data issued.
5. The report must not be used to claim product certification, approval, or endorsement by NVLAP, NIST, or any agency of the federal government.





Ecom Sertech Corp.

Rm. 258, Bldg. 17, NO.195, Sec. 4 Chung Hsing Rd., ChuTung Chen, Hsinchu, Taiwan 310, R.O.C
TEL:886-3-5918012 FAX: 886-3-5825720

FCC ID : Q5SWM68-1

Report No. : ER04-05-058FRF

Page 2 of 57

Test Report Certification

Product Name : 54Mbps 802.11g Wireless LAN MiniPCI Card
Model Number : WM68
FCC ID : Q5SWM68-1
Applicant : Fi Win, Inc.

Measurement Standard :

FCC 47 C.F.R. Part 15, Subpart B and Subpart C (2003),
 ANSI C63.4 (2001)

Tested By : Chris Huang May 31, 2004
 (Chris Huang)

Reviewed By : Roger Sheng May 31, 2004
 (Roger Sheng)

Approved By : Chieh-De Tsai May 31, 2004
 (Chieh-De Tsai ,Manager)



WE HEREBY CERTIFY THAT: The measurements shown in the attachment were made in accordance with the procedures indicated, and the energy emitted by the equipment was found to be within the limits applicable. We assume full responsibility for the accuracy and completeness of these measurements and vouch for the qualifications of all persons taking them.



TABLE OF CONTENTS

TITLE	PAGE NO.
1. GENERAL INFORMATION	5
1.1 General Statement	5
1.2 General Description of EUT & Power	5
1.3 Description of Peripherals	6
1.4 EUT & Peripherals Setup Diagram	7
1.5 EUT Operating Procedure	7
1.6 Description of Laboratory	8
1.7 Summary of Test Results	8
2. CONDUCTED POWERLINE TEST	9
2.1 Test Equipments	9
2.2 Test Setup	9
2.3 Conducted Power Line Emission Limit	10
2.4 Test Procedure	10
2.5 Uncertainty of Conducted Emission.....	10
2.6 Conducted RF Voltage Measurement	11-14
2.7 Photos of Conduction Test	15
3. RADIATED EMISSION TEST	16
3.1 Test Equipments	16
3.2 Test Setup	16
3.3 Radiation Limit	17
3.4 Test Procedures	18
3.5 Uncertainty of Radiated Emission.....	18
3.6 Radiated RF Noise Measurement.....	19-37
3.7 Photos of Open Site.....	38-39
4. 6dB BANDWIDTH MEASUREMENT	40
4.1 Test Equipments	40
4.2 Test Setup	40
4.3 Limits of 6dB Bandwidth Measurement	40
4.4 Test Procedure	40
4.5 Uncertainty of Conducted Emission.....	40
4.6 Test Results	41
4.7 Photo of 6db Bandwidth Measurement	42-43
5. MAXIMUM PEAK OUTPUT POWER	44
5.1 Test Equipments	44
5.2 Test Setup	44
5.3 Limits of Maximum Peak Output Power	44
5.4 Test Procedure	45
5.5 Uncertainty of Conducted Emission.....	45
5.6 Test Results	45
6. POWER SPECTRAL DENSITY MEASUREMENT	46
6.1 Test Equipments	46
6.2 Test Setup	46
6.3 Limits of Power Spectral Density Measurement.....	46
6.4 Test Procedure	47
6.5 Uncertainty of Conducted Emission.....	47
6.6 Test Results	47
6.7 Photo of Power Spectral Density Measurement.....	48-49



Ecom Sertech Corp.

Rm. 258, Bldg. 17, NO.195, Sec. 4 Chung Hsing Rd., ChuTung Chen, Hsinchu, Taiwan 310, R.O.C
TEL:886-3-5918012 FAX : 886-3-5825720

FCC ID : Q5SWM68-1

Report No. : ER04-05-058FRF

Page 4 of 57

TABLE OF CONTENTS

TITLE	PAGE NO.
7. BAND EDGE MEASUREMENT	50
7.1 Test Equipments	50
7.2 Test Setup	50
7.3 Limits of Band Edge Emissions Measurement	50
7.4 Test Procedure	51
7.5 Uncertainty of Conducted Emission.....	51
7.6 Test Results	51-52
7.7 Photo of Band edge Measurement.....	53-56
8. ANTENNA REQUIREMENT	57
8.1 Standard Applicable	57
8.2 Antenna Connected Construction.....	57



1. GENERAL INFORMATION

1.1 General Statement

MEASUREMENT DEVIATION : Comply with standard in full

TRACEABILITY : This test result is traceable to National or International std.

1.2 General Description of EUT & Power

PRODUCT NAME : 54Mbps 802.11g Wireless LAN MiniPCI Card

MODEL NAME : WM68

FREQUENCY RANGE : 2400MHz to 2483.5MHz

FREQUENCY CHANNEL : 2412MHz + 5×n (MHz), n=0, 1, 2,.....10

CHANNEL NUMBER : 11

CHANNEL SPACING : 5MHz

MAX AIR DATA RATE : 54Mbps (802.11g Mode), 11Mbps(802.11b Mode)

TYPE OF MODULATION : 802.11b : DSSS (CCK, DQPSK, DBPSK)

802.11g : OFDM (64QAM, 16AQM, QPSK, BPSK)

FREQUENCY SELECTION : by software / firmware

EUT DESCRIPTION : 2.4GHz (Orthogonal Frequency Division Multiplex

and Direct Sequence Spread Spectrum) data transceiver for
WLAN application

ANTENNA TYPE : PIFA Antenna , Antenna Gain : 2dBi.

POWER SOURCE : 3.3VDC (From PC)



1.3 Description of Peripherals

(1) Notebook PC

MANUFACTURER : COMPAQ CORP.
MODEL NUMBER : N800V
SERIAL NUMBER : 5Y33KSQZMOYL
FCC ID : DOC
POWER CORD : Unshielded, Detachable, 1.8m

Adapter

MANUFACTURER : COMPAQ CORP.
MODEL NUMBER : PPP009L
INPUT POWER : 100-240V, 50/60Hz, 1.7A
OUTPUT POWER : 18.5VDC, 65W, 3.5A

(2) Printer

MANUFACTURER : HP CORP.
MODEL NUMBER : C8952D
SERIAL NUMBER : CN29B181H7
INPUT POWER : 100-240VAC, 50/60Hz, 0.7A
SIGNAL CABLE : Shielded, Undetachable, 1.8m

(3) Notebook PC

MANUFACTURER : COMPAQ CORP.
MODEL NUMBER : N800V
SERIAL NUMBER : 5Y3EKSQZDITJ
FCC ID : DOC
POWER CORD : Unshielded, Detachable, 1.8m

Adapter

MANUFACTURER : COMPAQ CORP.
MODEL NUMBER : PPP009H
INPUT POWER : 100-240V, 50/60Hz, 1.7A
OUTPUT POWER : 18.5VDC, 65W, 3.5A

1.4 EUT & Peripherals Setup Diagram

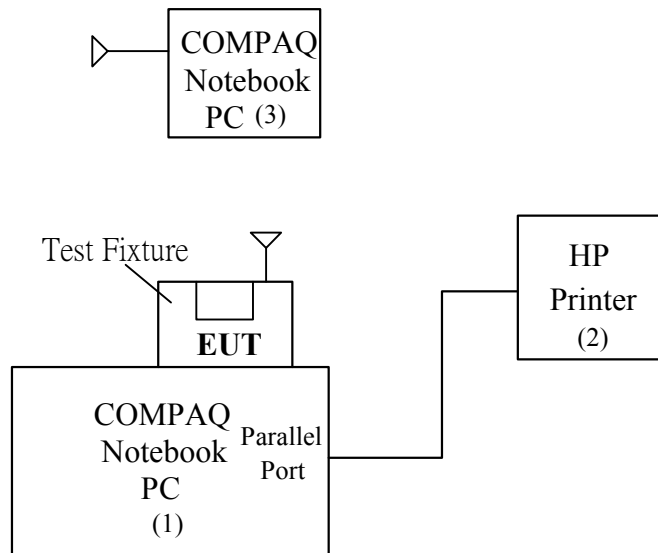

The indicated numbers (1)(2)(3), please refer to item 1.3

1.5 EUT Operating Procedure

1. Set up all computers like the setup diagram.
2. Notebook PC (1) ping 192.168.1.90 -t -l 5000 to EUT.
3. Notebook PC (3) ping 192.168.1.80 -t -l 5000 to Notebook (1).
4. All of the function are under run.
5. Run the test software to configure the channel, power, and data rate.
6. Start test.



Ecom Sertech Corp.

Rm. 258, Bldg. 17, NO.195, Sec. 4 Chung Hsing Rd., ChuTung Chen, Hsinchu, Taiwan 310, R.O.C
TEL:886-3-5918012 FAX : 886-3-5825720

FCC ID : Q5SWM68-1

Report No. : ER04-05-058FRF

Page 8 of 57

1.6 Description of Laboratory

SITE DESCRIPTION

FCC Certificate NO. : 90585
BSMI Certificate NO. : SL2-IN-E-0002
NVLAP Lab code : 200118-0
CNLA Certificate NO. : CNLA-ZL97018
VCCI Certificate NO. : R-1189, C-1250
TÜV Rheinland Certificate NO. : 10008375

NAME OF SITE : Ecom Sertech Corp. Hsin-Chu Lab.
(Spin-off from ITRI / ERSO on Apr. 01, 2003)

SITE LOCATION : Rm.258, Bldg.17, NO.195 , Sec. 4, Chung Hsing Rd.,
Chu-Tung Chen. Hsin-Chu, Taiwan 310 R.O.C.

1.7 Summary of Test Results

The EUT has been tested according to the following specifications :

APPLIED STANDARD : FCC 47 C.F.R. Part 15, Subpart B and Subpart C

Standard Section	Test Item and Limit	Result	REMARK
15.107 15.207	AC Power Conducted Emission Limit : 15.107	PASS	Meet the requirement of limit
15.247(a)(2)	Spectrum Bandwidth of a Orthogonal Frequency Division Multiplex System Limit : 6dB bandwidth > 500KHz	PASS	Meet the requirement of limit
15.247(b)	Maximum Peak Output Power Limit : max. 30dBm	PASS	Meet the requirement of limit
15.109 15.205 15.209	Transmitter Radiated Emissions Limit : Table 15.209	PASS	Meet the requirement of limit
15.247(d)	Power Spectral Density Limit : max. 8dBm	PASS	Meet the requirement of limit
15.247(c)	Out of Band Emission and Restricted Band Radiation Limit:20dB less than peak value of fundamental frequency Restricted band Limit:Table 15.209	PASS	Meet the requirement of limit



2. CONDUCTED POWERLINE TEST

2.1 Test Equipments

The following test equipments are used during the conducted powerline tests :

Manufacturer or Type	Model No.	Serial No.	Date of Calibration	Calibration Period	Remark
HP SPECTRUM ANALYZER & DISPLAY	8568A	2235A02320	November 14, 2003	1 Year	PRETEST
HP QUASI-PEAK ADAPTER	85650 A	2341A00672	November 14, 2003	1 Year	PRETEST
SOLAR ISOLATION TRANSFORMER	7032-1	N/A	N/A	N/A	FINAL
EMCO L.I.S.N.	3850/2	9311-1025 9401-1028	January 08, 2004 For Characteristic impedance	1 Year	FINAL
			May 18, 2004 For Insertion loss		
R & S TEST RECEIVER	ESHS 30	838550/003	February 11, 2004	1 Year	FINAL
KEENE SHIELDED ROOM	5983	No.1	July 10~12, 2003	N/A	FINAL
R & S PULSE LIMIT	EHS3Z2	357.8810.52	July 10, 2003	1 Year	FINAL
N TYPE COAXIAL CABLE	-----	-----	July 10, 2003	1 Year	FINAL
50Ω TERMINATOR	-----	-----	July 10, 2003	1 Year	FINAL

2.2 Test Setup

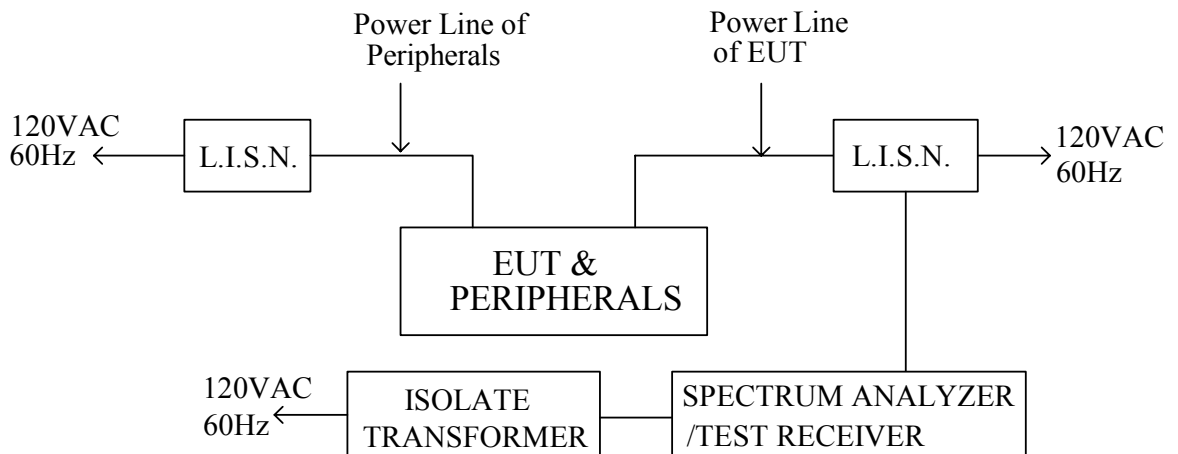



2.3 Conducted Power Line Emission Limit

For unintentional device, according to § 15.107(a) Line Conducted Emission Limits is as following :

Frequency (MHz)	Maximum RF Line Voltage (dB μ v)			
	CLASS A		CLASS B	
	Q.P.	Ave.	Q.P.	Ave.
0.15 - 0.50	79	66	66-56	56-46
0.50 - 5.00	73	60	56	46
5.00 - 30.0	73	60	60	50

For intentional device, according to § 15.207(a) Line Conducted Emission Limit is same as above table.

2.4 Test Procedure

The test procedure is performed in a 12ft×12ft×8ft(L×W×H) shielded room. The EUT along with its peripherals were placed on a 1.0m(W)× 1.5m(L) and 0.8m in height wooden table and the EUT was adjusted to maintain a 0.4 meter space from a vertical reference plane. The EUT was connected to power mains through a line impedance stabilization network (LISN) which provides 50 ohm coupling impedance for measuring instrument and the chasis ground was bounded to the horizontal ground plane of shielded room. All peripherals were connected to the second LISN and the chasis ground also bounded to the horizontal ground plane of shielded room. The excess power cable between the EUT and the LISN was bundled. The power cables of peripherals were unbundled. All connecting cables of EUT and peripherals were moved to find the maximum emission.

2.5 Uncertainty of Conducted Emission

The uncertainty of conducted emission is ± 1.36 dB.



2.6 Conducted RF Voltage Measurement

The frequency spectrum from 0.15 MHz to 30 MHz was investigated. All emissions not reported are much lower than the prescribed limits.

Company:	Fi Win, Inc.	Test Date :	2004/05/21
Product Name:	54Mbps 802.11g Wireless LAN MiniPCI Card	Test By:	Chris Huang
Model Name:	WM68	TEMP&Humidity :	25°C, 60%

LINE

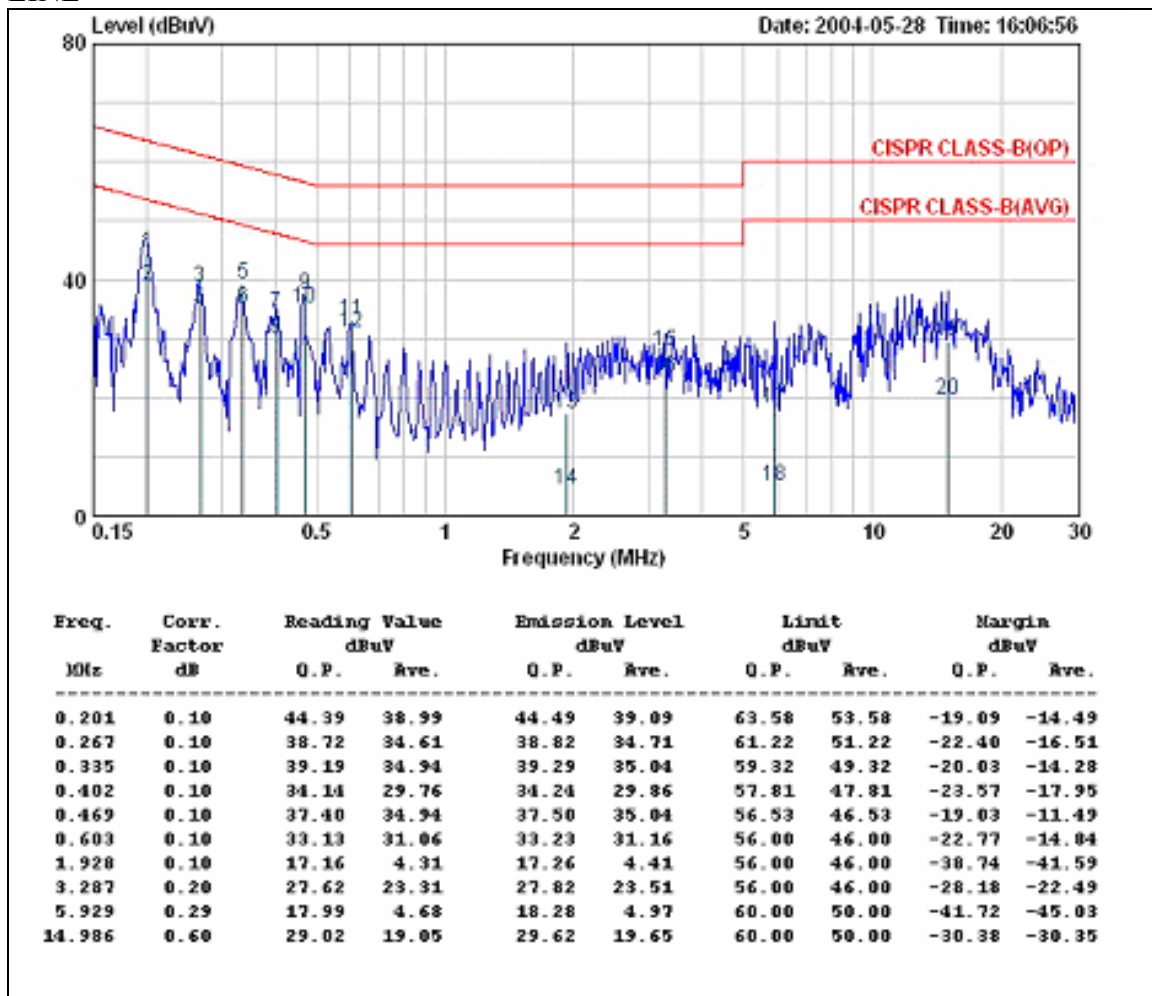

REMARKS :

1. Correction Factor = Insertion loss + cable loss
2. Margin value = Emission level – Limit value
3. For 802.11b mode.
4. The EUT can be operated in transmitting, stand-by and receiving mode. After preliminary scan, EUT in transmitting mode has highest emission. The EUT was set in transmitting mode at final test to get the worst case test results.



Ecom Sertech Corp.

Rm. 258, Bldg. 17, NO.195, Sec. 4 Chung Hsing Rd., ChuTung Chen, Hsinchu, Taiwan 310, R.O.C
 TEL:886-3-5918012 FAX : 886-3-5825720

FCC ID : Q5SWM68-1

Report No. : ER04-05-058FRF

Page 12 of 57

The frequency spectrum from 0.15 MHz to 30 MHz was investigated. All emissions not reported are much lower than the prescribed limits.

Company:	Fi Win, Inc.	Test Date :	2004/05/21
Product Name:	54Mbps 802.11g Wireless LAN MiniPCI Card	Test By:	Chris Huang
Model Name:	WM68	TEMP&Humidity :	25°C, 60%

NEUTRAL

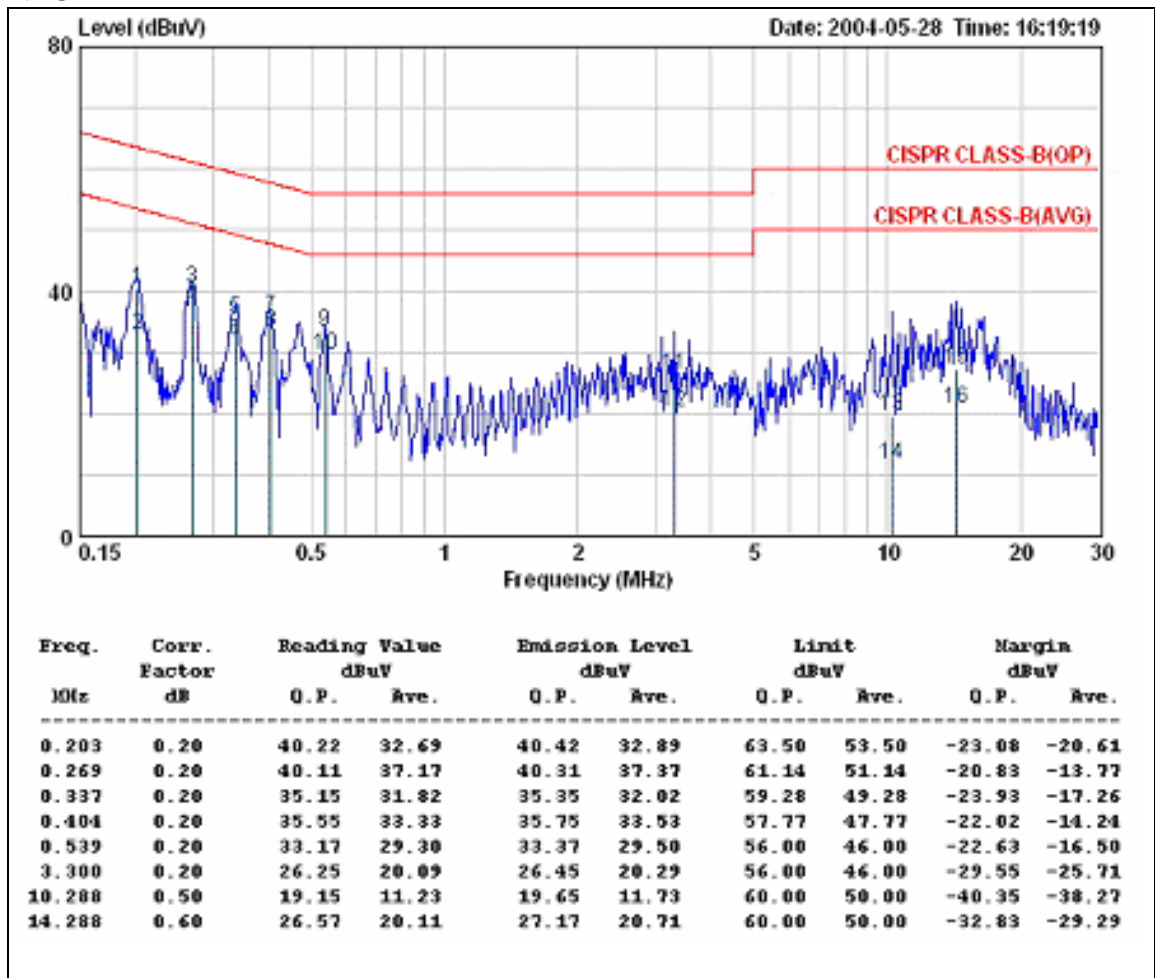

- REMARKS :
1. Correction Factor = Insertion loss + cable loss
 2. Margin value = Emission level – Limit value
 3. For 802.11b mode.
 4. The EUT can be operated in transmitting, stand-by and receiving mode. After preliminary scan, EUT in transmitting mode has highest emission. The EUT was set in transmitting mode at final test to get the worst case test results.



Ecom Sertech Corp.

Rm. 258, Bldg. 17, NO.195, Sec. 4 Chung Hsing Rd., ChuTung Chen, Hsinchu, Taiwan 310, R.O.C
 TEL:886-3-5918012 FAX : 886-3-5825720

FCC ID : Q5SWM68-1

Report No. : ER04-05-058FRF

Page 13 of 57

The frequency spectrum from 0.15 MHz to 30 MHz was investigated. All emissions not reported are much lower than the prescribed limits.

Company:	Fi Win, Inc.	Test Date :	2004/05/21
Product Name:	54Mbps 802.11g Wireless LAN MiniPCI Card	Test By:	Chris Huang
Model Name:	WM68	TEMP&Humidity :	25°C, 60%

LINE

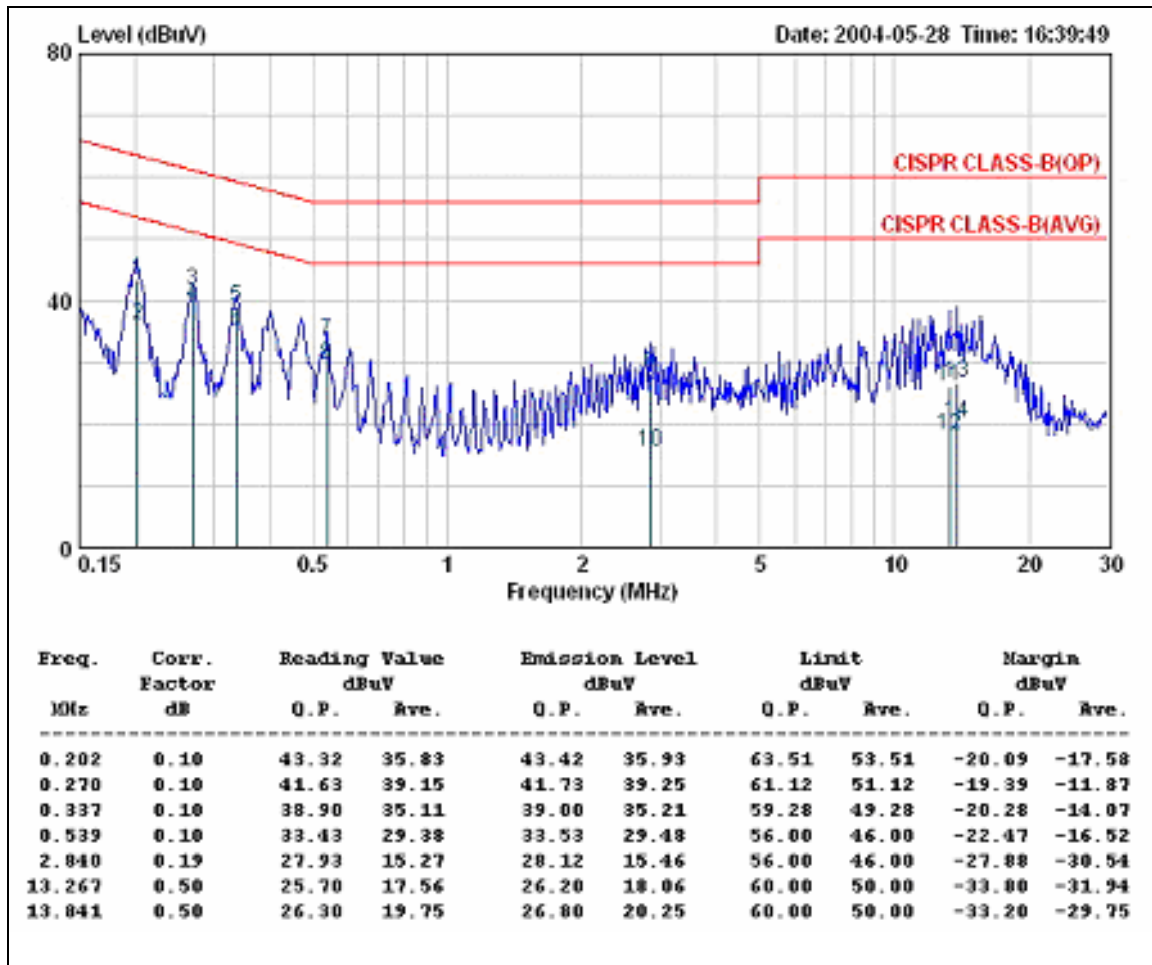

- REMARKS :
1. Correction Factor = Insertion loss + cable loss
 2. Margin value = Emission level – Limit value
 3. For 802.11g mode.
 4. The EUT can be operated in transmitting, stand-by and receiving mode. After preliminary scan, EUT in transmitting mode has highest emission. The EUT was set in transmitting mode at final test to get the worst case test results.



Ecom Sertech Corp.

Rm. 258, Bldg. 17, NO.195, Sec. 4 Chung Hsing Rd., ChuTung Chen, Hsinchu, Taiwan 310, R.O.C
 TEL:886-3-5918012 FAX : 886-3-5825720

FCC ID : Q5SWM68-1

Report No. : ER04-05-058FRF

Page 14 of 57

The frequency spectrum from 0.15 MHz to 30 MHz was investigated. All emissions not reported are much lower than the prescribed limits.

Company:	Fi Win, Inc.	Test Date :	2004/05/21
Product Name:	54Mbps 802.11g Wireless LAN MiniPCI Card	Test By:	Chris Huang
Model Name:	WM68	TEMP&Humidity :	25°C, 60%

NEUTRAL

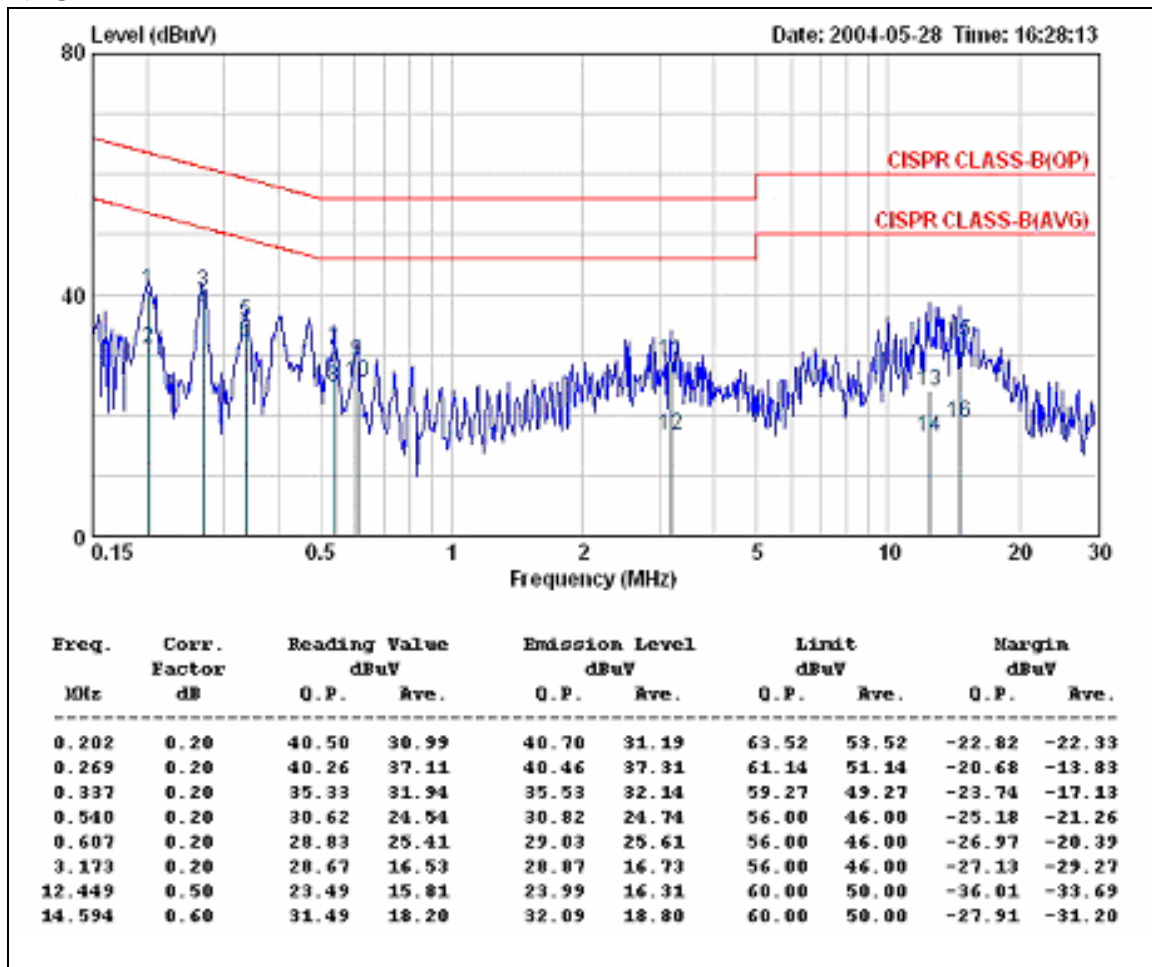

- REMARKS :
1. Correction Factor = Insertion loss + cable loss
 2. Margin value = Emission level – Limit value
 3. For 802.11g mode.
 4. The EUT can be operated in transmitting, stand-by and receiving mode. After preliminary scan, EUT in transmitting mode has highest emission. The EUT was set in transmitting mode at final test to get the worst case test results.

2.7 Photos of Conduction Test



3. RADIATED EMISSION TEST

3.1 Test Equipments

The following test equipments are utilized in making the measurements contained in this report.

Manufacturer or Type	Model No	Serial No	Date of Calibration	Calibration Period	Remark
CHASE BI-LOG ANTENNA	CBL6112B	2421	May 07, 2004	1 Year	FINAL
R/S SPECTRUM ANALYZER	FSEK30	835253/002	June 17, 2003	1 Year	FINAL
OPEN SITE	-----	No.2	May 07, 2004	1 Year	FINAL
N TYPE COAXIAL CABLE	CHA9525	4	July 13, 2003	1 Year	FINAL
Horn Antenna	AH-118	10089	February 25, 2004	1 Year	FINAL
HP Pre-amplifier	8449B	3008A01471	October 11, 2003	1 Year	FINAL
HP High pass filter	84300/80038	011	CAL. ON USE	1 Year	FINAL
Horn Antenna	AH-840	03077	February 25, 2004	1 Year	FINAL

3.2 Test Setup

The diagram below shows the test setup that is utilized to make the measurements for emission from 30 to 1GHz.

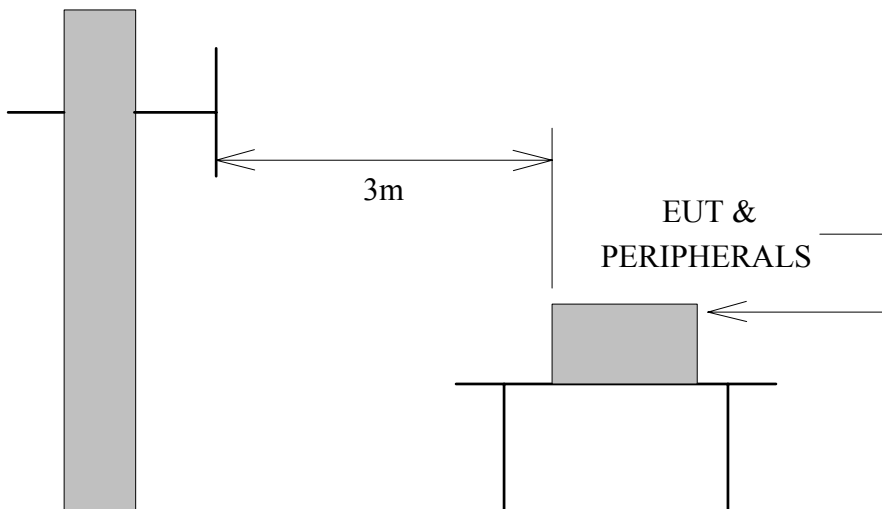

Antenna Elevation Variable

The diagram below shows the test setup that is utilized to make the measurements for emission above 1GHz.

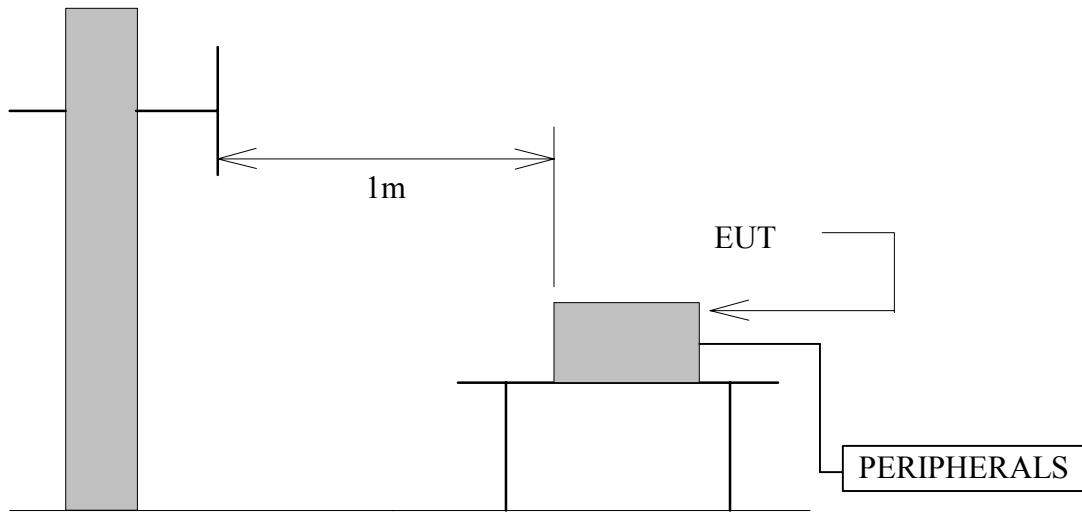

Antenna Elevation Variable

3.3 Radiation Limit

For unintentional device, according to § 15.109(a), except for Class A digital devices, the field strength of radiated emissions from unintentional radiators at a distance of 3 meters shall not exceed the following values :

Frequency (MHz)	Distance (Meters)	Radiated (dBµV/M)	Radiated (µV/M)
30-88	3	40.0	100
88-216	3	43.5	150
216-960	3	46.0	200
Above 960	3	54.0	500

For intentional device, according to § 15.209(a), the general requirement of field strength of radiated emissions from intentional radiators at a distance of 3 meters shall not exceed the above table. According to § 15.247(c), in any 100kHz bandwidth outside the frequency band in which the EUT is operating, the radiofrequency power that is produced by the intentional radiator shall be at least 20dB below that in the 100kHz bandwidth within the band that contains the highest level of desired power.



3.4 Test Procedures

- a. The EUT was placed on the top of a rotating table 0.8 meters above the ground at a 10 meter open area test site. The table was rotated 360 degrees to determine the position of the highest radiation.
- b. During performing radiated emission below 1GHz, the EUT was set 3 meters away from the interference-receiving antenna, which was mounted on the top of a variable-height antenna tower. During performing radiated emission above 1GHz, the EUT was set 1 meters away from the interference-receiving antenna
- c. The antenna is a broadband antenna, and its height is varied from one meter to four meters above the ground to determine the maximum value of the field strength. Both horizontal and vertical polarization of the antenna are set to make the measurement.
- d. For each suspected emission, the EUT was arranged to its worst case and then the antenna was tuned to heights from 1 meter to 4 meters and the table was turned from 0 degrees to 360 degrees to find the maximum reading.
- e. The test-receiver system was set to Peak Detect Function and Specified Bandwidth with Maximum Hold Mode.
- f. If the emission level of the EUT in peak mode was 10 dB lower than the limit specified, then testing could be stopped and the peak values of the EUT would be reported. Otherwise the emissions that did not have 10 dB margin would be re-tested one by one using peak, quasi-peak or average method as specified and then reported in a data sheet.

NOTE :

1. The resolution bandwidth and video bandwidth of test receiver/spectrum analyzer is 120 KHz for Peak detection (PK) and Quasi-peak detection (QP) at frequency below 1GHz.
2. The resolution bandwidth and video bandwidth of test receiver/spectrum analyzer is 1 MHz for Peak detection and frequency above 1GHz.
3. The resolution bandwidth of test receiver/spectrum analyzer is 1 MHz and the video bandwidth is 10 Hz for Average detection (AV) at frequency above 1GHz.

3.5 Uncertainty of Radiated Emission

The uncertainty of radiated emission is ± 2.72 dB.



3.6 Radiated RF Noise Measurement

Test Requirement: 15.109, 15.209

The frequency spectrum from 30 MHz to 1000 MHz was investigated. All emissions not reported are much lower than the prescribed limits.

All readings are quasi-peak values.

Temperature : 19 °C

Humidity : 71 % RH

Frequency (MHz)	Antenna Factor (dB)	Cable Loss (dB)	Meter Reading at 3m(dBµV/M)		Limits at 3m (dBµV/M)	Emission Level at 3m(dBµV/M)	
			Horizontal	Vertical		Horizontal	Vertical
30.00	21.39	0.90	*	*	40.00	*	*
132.96	13.22	2.15	25.80	17.60	43.50	41.17	32.97
199.99	10.39	2.80	27.00	22.50	43.50	40.19	35.69
232.55	12.15	3.06	22.40	12.50	46.00	37.61	27.71
239.99	12.55	3.12	23.90	13.60	46.00	39.57	29.27
265.83	13.22	3.33	17.60	0.00	46.00	34.15	16.55
279.99	13.34	3.44	21.30	14.70	46.00	38.08	31.48
299.04	13.49	3.59	18.00	0.00	46.00	35.08	17.08
319.99	14.25	3.72	18.50	9.90	46.00	36.47	27.87
359.99	15.74	3.96	18.10	9.20	46.00	37.80	28.90
1000.00	21.58	7.00	*	*	54.00	*	*

REMARKS :

- * Undetectable
- Emission level (dBµV/M) =Antenna Factor (dB/M) + Cable loss (dB) + Meter Reading (dBµV/M).
- According to technical experiences, all spurious emission at channel 1,6,11 are almost the same below 1GHz,so that the channel 1 was chosen as representative in finial test.
- The RF-Chip combined with 802.11b&g mode. It will auto-detect the situation then switch the mode. The 802.11g mode is the worse case than the 802.11b mode. So only the 802.11g mode data are recorded in finial test report.
- The test data marked in gray background means the EUT emission data is located in the margin uncertainty range of emission limits.



Ecom Sertech Corp.

Rm. 258, Bldg. 17, NO.195, Sec. 4 Chung Hsing Rd., ChuTung Chen, Hsinchu, Taiwan 310, R.O.C
 TEL:886-3-5918012 FAX : 886-3-5825720

FCC ID : Q5SWM68-1
 Report No. : ER04-05-058FRF
 Page 20 of 57

The frequency spectrum above 1 GHz was investigated. All emissions not reported are much lower than the prescribed limits. Readings are both peak and average values.

Company :	Fi Win, Inc.	Test Date :	2004/05/21
Product Name :	54Mbps 802.11g Wireless LAN MiniPCI Card	Test By:	Chris Huang
Model Name :	WM68	TEMP&Humidity :	20.9°C , 73%

CH1 RX				Measurement Distance at 1m				Horizontal polarity			
Freq.	Reading	AF	Cable	Pre-amp	Dist	Filter	Level	Limit	Margin	Mark	Height
(MHz)	(dBuV)	(dBuV)	(dB)	(dB)	dB	dB	(dBuV/m)	(dBuV/m)	(dB)	(P/Q/A)	(Meter)
4823.95	47.28	34.44	5.08	35.16	9.50	0.00	42.14	74	-31.86	P	1.0
4823.95	37.67	34.44	5.08	35.16	9.50	0.00	32.53	54	-21.47	A	1.0
7236.00	45.38	39.81	6.74	35.65	9.50	0.00	46.77	74	-27.23	P	1.0
7236.00	33.35	39.81	6.74	35.65	9.50	0.00	34.74	54	-19.26	A	1.0
9647.89	49.11	38.54	8.29	36.44	9.50	0.00	50.00	74	-24.00	P	1.0
9647.89	39.82	38.54	8.29	36.44	9.50	0.00	40.71	54	-13.29	A	1.0

1. AF: Antenna Factor, Cable: Cable Loss, Pre-Amp: Preamplifier gain, Filter: High Pass Filter Insertion Loss (3.5GHz)
2. Analyzer setting P(Peak): RBW=1MHz, VBW=1MHz, A(Average): RBW=1MHz,VBW=10Hz
3. Dist : correction to extra plate reading to 3m specification distance 1m measurement distance = -9.5dB
4. The result basic equation calculation as follow :

$$\text{Level} = \text{Reading} + \text{AF} + \text{Cable} - \text{Preamp} + \text{Filter} - \text{Dist}, \text{Margin} = \text{Level} - \text{Limit}$$
5. The test limit is 3M limit.
6. The frequency was searched to 18GHz.
7. The other emission levels were very low against the limit.



Ecom Sertech Corp.

Rm. 258, Bldg. 17, NO.195, Sec. 4 Chung Hsing Rd., ChuTung Chen, Hsinchu, Taiwan 310, R.O.C
TEL:886-3-5918012 FAX : 886-3-5825720

FCC ID : Q5SWM68-1

Report No. : ER04-05-058FRF

Page 21 of 57

The frequency spectrum above 1 GHz was investigated. All emissions not reported are much lower than the prescribed limits. Readings are both peak and average values.

Company :	Fi Win, Inc.	Test Date :	2004/05/21
Product Name :	54Mbps 802.11g Wireless LAN MiniPCI Card	Test By:	Chris Huang
Model Name :	WM68	TEMP&Humidity :	20.9°C , 73%

CH1 RX				Measurement Distance at 1m					Vertical polarity			
Freq.	Reading	AF	Cable	Pre-amp	Dist	Filter	Level	Limit	Margin	Mark	Height	
(MHz)	(dBuV)	(dBuV)	(dB)	(dB)	dB	dB	(dBuV/m)	(dBuV/m)	(dB)	(P/Q/A)	(Meter)	
4824.01	46.98	34.44	5.08	35.16	9.50	0.00	41.84	74	-32.16	P	1.0	
4824.01	36.79	34.44	5.08	35.16	9.50	0.00	31.65	54	-22.35	A	1.0	
7236.07	44.98	39.81	6.74	35.65	9.50	0.00	46.37	74	-27.63	P	1.0	
7236.07	33.17	39.81	6.74	35.65	9.50	0.00	34.56	54	-19.44	A	1.0	
9648.03	50.67	38.54	8.29	36.44	9.50	0.00	51.56	74	-22.44	P	1.0	
9648.03	44.49	38.54	8.29	36.44	9.50	0.00	45.38	54	-8.62	A	1.0	

1. AF: Antenna Factor, Cable: Cable Loss, Pre-Amp: Preamplifier gain, Filter: High Pass Filter Insertion Loss (3.5GHz)
2. Analyzer setting P(Peak): RBW=1MHz, VBW=1MHz, A(Average): RBW=1MHz,VBW=10Hz
3. Dist : correction to extra plate reading to 3m specification distance 1m measurement distance = -9.5dB
4. The result basic equation calculation as follow :
Level = Reading + AF + Cable - Preamp + Filter - Dist, Margin = Level - Limit
5. The test limit is 3M limit.
6. The frequency was searched to 18GHz.
7. The other emission levels were very low against the limit.



Ecom Sertech Corp.

Rm. 258, Bldg. 17, NO.195, Sec. 4 Chung Hsing Rd., ChuTung Chen, Hsinchu, Taiwan 310, R.O.C
TEL:886-3-5918012 FAX : 886-3-5825720

FCC ID : Q5SWM68-1

Report No. : ER04-05-058FRF

Page 22 of 57

The frequency spectrum above 1 GHz was investigated. All emissions not reported are much lower than the prescribed limits. Readings are both peak and average values.

Company :	Fi Win, Inc.	Test Date :	2004/05/21
Product Name :	54Mbps 802.11g Wireless LAN MiniPCI Card	Test By:	Chris Huang
Model Name :	WM68	TEMP&Humidity :	20.9°C , 73%

CH6 RX				Measurement Distance at 1m				Horizontal polarity			
Freq.	Reading	AF	Cable	Pre-amp	Dist	Filter	Level	Limit	Margin	Mark	Height
(MHz)	(dBuV)	(dBuV)	(dB)	(dB)	dB	dB	(dBuV/m)	(dBuV/m)	(dB)	(P/Q/A)	(Meter)
4873.83	47.12	34.77	5.10	35.20	9.50	0.00	42.29	74	-31.71	P	1.0
4873.83	37.51	34.77	5.10	35.20	9.50	0.00	32.68	54	-21.32	A	1.0
7311.00	44.98	39.78	6.79	35.64	9.50	0.00	46.41	74	-27.59	P	1.0
7311.00	33.19	39.78	6.79	35.64	9.50	0.00	34.62	54	-19.38	A	1.0
9747.94	48.63	38.53	8.33	36.60	9.50	0.00	49.39	74	-24.61	P	1.0
9747.94	39.48	38.53	8.33	36.60	9.50	0.00	40.24	54	-13.76	A	1.0

1. AF: Antenna Factor, Cable: Cable Loss, Pre-Amp: Preamplifier gain, Filter: High Pass Filter Insertion Loss (3.5GHz)
2. Analyzer setting P(Peak): RBW=1MHz, VBW=1MHz, A(Average): RBW=1MHz,VBW=10Hz
3. Dist : correction to extra plate reading to 3m specification distance 1m measurement distance = -9.5dB
4. The result basic equation calculation as follow :
Level = Reading + AF + Cable - Preamp + Filter - Dist, Margin = Level - Limit
5. The test limit is 3M limit.
6. The frequency was searched to 18GHz.
7. The other emission levels were very low against the limit.



Ecom Sertech Corp.

Rm. 258, Bldg. 17, NO.195, Sec. 4 Chung Hsing Rd., ChuTung Chen, Hsinchu, Taiwan 310, R.O.C
 TEL:886-3-5918012 FAX : 886-3-5825720

FCC ID : Q5SWM68-1

Report No. : ER04-05-058FRF

Page 23 of 57

The frequency spectrum above 1 GHz was investigated. All emissions not reported are much lower than the prescribed limits. Readings are both peak and average values.

Company :	Fi Win, Inc.	Test Date :	2004/05/21
Product Name :	54Mbps 802.11g Wireless LAN MiniPCI Card	Test By:	Chris Huang
Model Name :	WM68	TEMP&Humidity :	20.9°C , 73%

CH6 RX				Measurement Distance at 1m					Vertical polarity			
Freq.	Reading	AF	Cable	Pre-amp	Dist	Filter	Level	Limit	Margin	Mark	Height	
(MHz)	(dBuV)	(dBuV)	(dB)	(dB)	dB	dB	(dBuV/m)	(dBuV/m)	(dB)	(P/Q/A)	(Meter)	
4873.98	47.03	34.77	5.10	35.20	9.50	0.00	42.20	74	-31.80	P	1.0	
4873.98	36.82	34.77	5.10	35.20	9.50	0.00	31.99	54	-22.01	A	1.0	
7311.01	45.19	39.78	6.79	35.64	9.50	0.00	46.62	74	-27.38	P	1.0	
7311.01	33.70	39.78	6.79	35.64	9.50	0.00	35.13	54	-18.87	A	1.0	
9747.85	50.17	38.53	8.33	36.60	9.50	0.00	50.93	74	-23.07	P	1.0	
9747.85	44.02	38.53	8.33	36.60	9.50	0.00	44.78	54	-9.22	A	1.0	

1. AF: Antenna Factor, Cable: Cable Loss, Pre-Amp: Preamplifier gain, Filter: High Pass Filter Insertion Loss (3.5GHz)
2. Analyzer setting P(Peak): RBW=1MHz, VBW=1MHz, A(Average): RBW=1MHz,VBW=10Hz
3. Dist : correction to extra plate reading to 3m specification distance 1m measurement distance = -9.5dB
4. The result basic equation calculation as follow :

$$\text{Level} = \text{Reading} + \text{AF} + \text{Cable} - \text{Preamp} + \text{Filter} - \text{Dist}, \text{Margin} = \text{Level} - \text{Limit}$$
5. The test limit is 3M limit.
6. The frequency was searched to 18GHz.
7. The other emission levels were very low against the limit.



Ecom Sertech Corp.

Rm. 258, Bldg. 17, NO.195, Sec. 4 Chung Hsing Rd., ChuTung Chen, Hsinchu, Taiwan 310, R.O.C
TEL:886-3-5918012 FAX : 886-3-5825720

FCC ID : Q5SWM68-1

Report No. : ER04-05-058FRF

Page 24 of 57

The frequency spectrum above 1 GHz was investigated. All emissions not reported are much lower than the prescribed limits. Readings are both peak and average values.

Company :	Fi Win, Inc.	Test Date :	2004/05/21
Product Name :	54Mbps 802.11g Wireless LAN MiniPCI Card	Test By:	Chris Huang
Model Name :	WM68	TEMP&Humidity :	20.9°C , 73%

CH11 RX				Measurement Distance at 1m				Horizontal polarity			
Freq.	Reading	AF	Cable	Pre-amp	Dist	Filter	Level	Limit	Margin	Mark	Height
(MHz)	(dBuV)	(dBuV)	(dB)	(dB)	dB	dB	(dBuV/m)	(dBuV/m)	(dB)	(P/Q/A)	(Meter)
4923.97	46.77	35.10	5.12	35.24	9.50	0.00	42.24	74	-31.76	P	1.0
4923.97	37.28	35.10	5.12	35.24	9.50	0.00	32.75	54	-21.25	A	1.0
7385.99	45.38	39.75	6.84	35.62	9.50	0.00	46.85	74	-27.15	P	1.0
7385.99	33.35	39.75	6.84	35.62	9.50	0.00	34.82	54	-19.18	A	1.0
9848.06	49.08	38.52	8.37	36.76	9.50	0.00	49.70	74	-24.30	P	1.0
9848.06	40.99	38.52	8.37	36.76	9.50	0.00	41.61	54	-12.39	A	1.0

1. AF: Antenna Factor, Cable: Cable Loss, Pre-Amp: Preamplifier gain, Filter: High Pass Filter Insertion Loss (3.5GHz)
2. Analyzer setting P(Peak): RBW=1MHz, VBW=1MHz, A(Average): RBW=1MHz,VBW=10Hz
3. Dist : correction to extra plate reading to 3m specification distance 1m measurement distance = -9.5dB
4. The result basic equation calculation as follow :
Level = Reading + AF + Cable - Preamp + Filter - Dist, Margin = Level - Limit
5. The test limit is 3M limit.
6. The frequency was searched to 18GHz.
7. The other emission levels were very low against the limit.



Ecom Sertech Corp.

Rm. 258, Bldg. 17, NO.195, Sec. 4 Chung Hsing Rd., ChuTung Chen, Hsinchu, Taiwan 310, R.O.C
TEL:886-3-5918012 FAX : 886-3-5825720

FCC ID : Q5SWM68-1

Report No. : ER04-05-058FRF

Page 25 of 57

The frequency spectrum above 1 GHz was investigated. All emissions not reported are much lower than the prescribed limits. Readings are both peak and average values.

Company :	Fi Win, Inc.	Test Date :	2004/05/21
Product Name :	54Mbps 802.11g Wireless LAN MiniPCI Card	Test By:	Chris Huang
Model Name :	WM68	TEMP&Humidity :	20.9°C , 73%

CH11 RX				Measurement Distance at 1m					Vertical polarity			
Freq.	Reading	AF	Cable	Pre-amp	Dist	Filter	Level	Limit	Margin	Mark	Height	
(MHz)	(dBuV)	(dBuV)	(dB)	(dB)	dB	dB	(dBuV/m)	(dBuV/m)	(dB)	(P/Q/A)	(Meter)	
4923.91	46.89	35.10	5.12	35.24	9.50	0.00	42.36	74	-31.64	P	1.0	
4923.91	37.05	35.10	5.12	35.24	9.50	0.00	32.52	54	-21.48	A	1.0	
7386.07	45.27	39.75	6.84	35.62	9.50	0.00	46.74	74	-27.26	P	1.0	
7386.07	33.62	39.75	6.84	35.62	9.50	0.00	35.09	54	-18.91	A	1.0	
9847.83	50.37	38.52	8.37	36.76	9.50	0.00	50.99	74	-23.01	P	1.0	
9847.83	43.87	38.52	8.37	36.76	9.50	0.00	44.49	54	-9.51	A	1.0	

1. AF: Antenna Factor, Cable: Cable Loss, Pre-Amp: Preamplifier gain, Filter: High Pass Filter Insertion Loss (3.5GHz)
2. Analyzer setting P(Peak): RBW=1MHz, VBW=1MHz, A(Average): RBW=1MHz,VBW=10Hz
3. Dist : correction to extra plate reading to 3m specification distance 1m measurement distance = -9.5dB
4. The result basic equation calculation as follow :
Level = Reading + AF + Cable - Preamp + Filter - Dist, Margin = Level - Limit
5. The test limit is 3M limit.
6. The frequency was searched to 18GHz.
7. The other emission levels were very low against the limit.



Ecom Sertech Corp.

Rm. 258, Bldg. 17, NO.195, Sec. 4 Chung Hsing Rd., ChuTung Chen, Hsinchu, Taiwan 310, R.O.C
 TEL:886-3-5918012 FAX : 886-3-5825720

FCC ID : Q5SWM68-1

Report No. : ER04-05-058FRF

Page 26 of 57

The frequency spectrum above 1 GHz was investigated. All emissions not reported are much lower than the prescribed limits. Readings are both peak and average values.

Company :	Fi Win, Inc.	Test Date :	2004/05/21
Product Name :	54Mbps 802.11g Wireless LAN MiniPCI Card	Test By:	Chris Huang
Model Name :	WM68	TEMP&Humidity :	23.9°C , 65%

CH1 TX				Measurement Distance at 1m				Horizontal polarity			
Freq.	Reading	AF	Cable	Pre-amp	Dist	Filter	Level	Limit	Margin	Mark	Height
(MHz)	(dBuV)	(dBuV)	(dB)	(dB)	dB	dB	(dBuV/m)	(dBuV/m)	(dB)	(P/Q/A)	(Meter)
* 2389.90	29.48	31.81	3.57	0.00	9.50	0.00	55.36	74	-18.64	P	1.00
* 2389.90	17.14	31.81	3.57	0.00	9.50	0.00	43.02	54	-10.98	A	1.00
2413.30	77.43	31.79	3.58	0.00	9.50	0.00	103.30	Fundamental Frequency		P	1.00
2413.30	70.64	31.79	3.58	0.00	9.50	0.00	96.51			A	1.00
* 4823.86	46.29	34.44	5.08	35.16	9.50	2.00	43.16	74	-30.84	P	1.00
* 4823.86	36.37	34.44	5.08	35.16	9.50	2.00	33.24	54	-20.76	A	1.00
7236.00	44.51	39.81	6.74	35.65	9.50	2.00	47.90	74	-26.10	P	1.00
7236.00	33.62	39.81	6.74	35.65	9.50	2.00	37.01	54	-16.99	A	1.00
9648.00	49.37	38.54	8.29	36.44	9.50	0.61	50.87	74	-23.13	P	1.00
9648.00	39.89	38.54	8.29	36.44	9.50	0.61	41.39	54	-12.61	A	1.00
* 12066.50	-----	-----	-----	-----	9.50	0.80	-----	-----	-----	-----	1.00
* 14479.80	-----	-----	-----	-----	0.00	0.68	-----	-----	-----	-----	1.00
16893.10	-----	-----	-----	-----	0.00	0.44	-----	-----	-----	-----	1.00
* 19306.40	-----	-----	-----	-----	0.00	1.97	-----	-----	-----	-----	1.00
21719.70	-----	-----	-----	-----	0.00	0.81	-----	-----	-----	-----	1.00
24133.00	-----	-----	-----	-----	0.00	2.89	-----	-----	-----	-----	1.00

Note :

- The measurement was searched to 10th harmonic, Remark “---” means that the emissions level is too low to be measured.
- AF: Antenna Factor, Cable: Cable Loss, Pre-Amp: Preamplifier gain, Filter: High Pass Filter Insertion Loss (3.5GHz)
- Analyzer setting P(Peak): RBW=1MHz, VBW=1MHz, A(Average): RBW=1MHz, VBW=10Hz
- Remark “*” means the Restricted band.
- Dist : correction to extra plate reading to 3m specification distance 1m measurement distance = -9.5dB
- The result basic equation calculation is as follow:
 $Level = Reading + AF + Cable - Preamp + Filter - Dist$, $Margin = Level - Limit$
- The other emission levels were very low against the limit
- The test limit distance is 3M limit.
- For 802.11b mode at 11Mbps.



Ecom Sertech Corp.

Rm. 258, Bldg. 17, NO.195, Sec. 4 Chung Hsing Rd., ChuTung Chen, Hsinchu, Taiwan 310, R.O.C
 TEL:886-3-5918012 FAX : 886-3-5825720

FCC ID : Q5SWM68-1

Report No. : ER04-05-058FRF

Page 27 of 57

The frequency spectrum above 1 GHz was investigated. All emissions not reported are much lower than the prescribed limits. Readings are both peak and average values.

Company :	Fi Win, Inc.	Test Date :	2004/05/21
Product Name :	54Mbps 802.11g Wireless LAN MiniPCI Card	Test By:	Chris Huang
Model Name :	WM68	TEMP&Humidity :	23.9°C , 65%

CH1 TX				Measurement Distance at 1m				Vertical polarity			
Freq.	Reading	AF	Cable	Pre-amp	Dist	Filter	Level	Limit	Margin	Mark	Height
(MHz)	(dBuV)	(dBuV)	(dB)	(dB)	dB	dB	(dBuV/m)	(dBuV/m)	(dB)	(P/Q/A)	(Meter)
* 2389.90	28.14	31.81	3.57	0.00	9.50	0.00	54.02	74	-19.98	P	1.00
* 2389.90	17.00	31.81	3.57	0.00	9.50	0.00	42.88	54	-11.12	A	1.00
2413.30	75.81	31.79	3.58	0.00	9.50	0.00	101.68	Fundamental Frequency		P	1.00
2413.30	69.02	31.79	3.58	0.00	9.50	0.00	94.89			A	1.00
* 4823.91	46.72	34.44	5.08	35.16	9.50	2.00	43.59	74	-30.41	P	1.00
* 4823.91	37.86	34.44	5.08	35.16	9.50	2.00	34.73	54	-19.27	A	1.00
7236.02	45.01	39.81	6.74	35.65	9.50	2.00	48.40	74	-25.60	P	1.00
7236.02	33.25	39.81	6.74	35.65	9.50	2.00	36.64	54	-17.36	A	1.00
9648.00	48.59	38.54	8.29	36.44	9.50	0.61	50.09	74	-23.91	P	1.00
9648.00	40.37	38.54	8.29	36.44	9.50	0.61	41.87	54	-12.13	A	1.00
* 12066.50	-----	-----	-----	-----	9.50	0.80	-----	-----	-----	-----	1.00
* 14479.80	-----	-----	-----	-----	0.00	0.68	-----	-----	-----	-----	1.00
16893.10	-----	-----	-----	-----	0.00	0.44	-----	-----	-----	-----	1.00
* 19306.40	-----	-----	-----	-----	0.00	1.97	-----	-----	-----	-----	1.00
21719.70	-----	-----	-----	-----	0.00	0.81	-----	-----	-----	-----	1.00
24133.00	-----	-----	-----	-----	0.00	2.89	-----	-----	-----	-----	1.00

Note :

- The measurement was searched to 10th harmonic, Remark “---” means that the emissions level is too low to be measured.
- AF: Antenna Factor, Cable: Cable Loss, Pre-Amp: Preamplifier gain, Filter: High Pass Filter Insertion Loss (3.5GHz)
- Analyzer setting P(Peak): RBW=1MHz, VBW=1MHz, A(Average): RBW=1MHz, VBW=10Hz
- Remark “*” means the Restricted band.
- Dist : correction to extra plate reading to 3m specification distance 1m measurement distance = -9.5dB
- The result basic equation calculation is as follow:
 $Level = Reading + AF + Cable - Preamp + Filter - Dist$, $Margin = Level - Limit$
- The other emission levels were very low against the limit
- The test limit distance is 3M limit.
- For 802.11b mode at 11Mbps.



Ecom Sertech Corp.

Rm. 258, Bldg. 17, NO.195, Sec. 4 Chung Hsing Rd., ChuTung Chen, Hsinchu, Taiwan 310, R.O.C
 TEL:886-3-5918012 FAX : 886-3-5825720

FCC ID : Q5SWM68-1

Report No. : ER04-05-058FRF

Page 28 of 57

The frequency spectrum above 1 GHz was investigated. All emissions not reported are much lower than the prescribed limits. Readings are both peak and average values.

Company :	Fi Win, Inc.	Test Date :	2004/05/21
Product Name :	54Mbps 802.11g Wireless LAN MiniPCI Card	Test By:	Chris Huang
Model Name :	WM68	TEMP&Humidity :	23.9°C , 65%

CH6 TX				Measurement Distance at 1m				Horizontal polarity			
Freq.	Reading	AF	Cable	Pre-amp	Dist	Filter	Level	Limit	Margin	Mark	Height
(MHz)	(dBuV)	(dBuV)	(dB)	(dB)	dB	dB	(dBuV/m)	(dBuV/m)	(dB)	(P/Q/A)	(Meter)
2436.83	77.03	31.76	3.59	0.00	9.50	0.00	102.89	Fundamental Frequency		P	1.00
2436.83	70.79	31.76	3.59	0.00	9.50	0.00	96.65			A	1.00
* 4874.07	46.57	34.77	5.10	35.20	9.50	1.80	43.54	74	-30.46	P	1.00
* 4874.07	37.31	34.77	5.10	35.20	9.50	1.80	34.28	54	-19.72	A	1.00
* 7311.01	44.68	39.78	6.79	35.64	9.50	2.00	48.11	74	-25.89	P	1.00
* 7311.01	33.10	39.78	6.79	35.64	9.50	2.00	36.53	54	-17.47	A	1.00
9747.98	49.55	38.53	8.33	36.60	9.50	0.55	50.86	74	-23.14	P	1.00
9747.98	41.24	38.53	8.33	36.60	9.50	0.55	42.55	54	-11.45	A	1.00
* 12184.15	-----	-----	-----	-----	9.50	0.80	-----	-----	-----	-----	1.00
14620.98	-----	-----	-----	-----	0.00	0.60	-----	-----	-----	-----	1.00
17057.81	-----	-----	-----	-----	0.00	0.52	-----	-----	-----	-----	1.00
* 19494.64	-----	-----	-----	-----	0.00	2.19	-----	-----	-----	-----	1.00
21931.47	-----	-----	-----	-----	0.00	0.73	-----	-----	-----	-----	1.00
24368.30	-----	-----	-----	-----	0.00	2.51	-----	-----	-----	-----	1.00

Note :

- The measurement was searched to 10th harmonic, Remark “---” means that the emissions level is too low to be measured.
- AF: Antenna Factor, Cable: Cable Loss, Pre-Amp: Preamplifier gain, Filter: High Pass Filter Insertion Loss (3.5GHz)
- Analyzer setting P(Peak): RBW=1MHz, VBW=1MHz, A(Average): RBW=1MHz, VBW=10Hz
- Remark “*” means the Restricted band.
- Dist : correction to extra plate reading to 3m specification distance 1m measurement distance = -9.5dB
- The result basic equation calculation is as follow:
 $Level = Reading + AF + Cable - Preamp + Filter - Dist$, $Margin = Level - Limit$
- The other emission levels were very low against the limit
- The test limit distance is 3M limit.
- For 802.11b mode at 11Mbps.



Ecom Sertech Corp.

Rm. 258, Bldg. 17, NO.195, Sec. 4 Chung Hsing Rd., ChuTung Chen, Hsinchu, Taiwan 310, R.O.C
 TEL:886-3-5918012 FAX : 886-3-5825720

FCC ID : Q5SWM68-1

Report No. : ER04-05-058FRF

Page 29 of 57

The frequency spectrum above 1 GHz was investigated. All emissions not reported are much lower than the prescribed limits. Readings are both peak and average values.

Company :	Fi Win, Inc.	Test Date :	2004/05/21
Product Name :	54Mbps 802.11g Wireless LAN MiniPCI Card	Test By:	Chris Huang
Model Name :	WM68	TEMP&Humidity :	23.9°C , 65%

CH6 TX				Measurement Distance at 1m				Vertical polarity			
Freq.	Reading	AF	Cable	Pre-amp	Dist	Filter	Level	Limit	Margin	Mark	Height
(MHz)	(dBuV)	(dBuV)	(dB)	(dB)	dB	dB	(dBuV/m)	(dBuV/m)	(dB)	(P/Q/A)	(Meter)
2436.83	77.03	31.76	3.59	0.00	9.50	0.00	102.89	Fundamental Frequency		P	1.00
2436.83	70.79	31.76	3.59	0.00	9.50	0.00	96.65			A	1.00
* 4874.07	46.57	34.77	5.10	35.20	9.50	1.80	43.54	74	-30.46	P	1.00
* 4874.07	37.31	34.77	5.10	35.20	9.50	1.80	34.28	54	-19.72	A	1.00
* 7311.01	44.68	39.78	6.79	35.64	9.50	2.00	48.11	74	-25.89	P	1.00
* 7311.01	33.10	39.78	6.79	35.64	9.50	2.00	36.53	54	-17.47	A	1.00
9747.98	49.55	38.53	8.33	36.60	9.50	0.55	50.86	74	-23.14	P	1.00
9747.98	41.24	38.53	8.33	36.60	9.50	0.55	42.55	54	-11.45	A	1.00
* 12184.15	-----	-----	-----	-----	9.50	0.80	-----	-----	-----	-----	1.00
14620.98	-----	-----	-----	-----	0.00	0.60	-----	-----	-----	-----	1.00
17057.81	-----	-----	-----	-----	0.00	0.52	-----	-----	-----	-----	1.00
* 19494.64	-----	-----	-----	-----	0.00	2.19	-----	-----	-----	-----	1.00
21931.47	-----	-----	-----	-----	0.00	0.73	-----	-----	-----	-----	1.00
24368.30	-----	-----	-----	-----	0.00	2.51	-----	-----	-----	-----	1.00

Note :

- The measurement was searched to 10th harmonic, Remark “---” means that the emissions level is too low to be measured.
- AF: Antenna Factor, Cable: Cable Loss, Pre-Amp: Preamplifier gain, Filter: High Pass Filter Insertion Loss (3.5GHz)
- Analyzer setting P(Peak): RBW=1MHz, VBW=1MHz, A(Average): RBW=1MHz, VBW=10Hz
- Remark “*” means the Restricted band.
- Dist : correction to extra plate reading to 3m specification distance 1m measurement distance = -9.5dB
- The result basic equation calculation is as follow:
 $Level = Reading + AF + Cable - Preamp + Filter - Dist$, $Margin = Level - Limit$
- The other emission levels were very low against the limit
- The test limit distance is 3M limit.
- For 802.11b mode at 11Mbps.



Ecom Sertech Corp.

Rm. 258, Bldg. 17, NO.195, Sec. 4 Chung Hsing Rd., ChuTung Chen, Hsinchu, Taiwan 310, R.O.C
 TEL:886-3-5918012 FAX : 886-3-5825720

FCC ID : Q5SWM68-1

Report No. : ER04-05-058FRF

Page 30 of 57

The frequency spectrum above 1 GHz was investigated. All emissions not reported are much lower than the prescribed limits. Readings are both peak and average values.

Company :	Fi Win, Inc.	Test Date :	2004/05/21
Product Name :	54Mbps 802.11g Wireless LAN MiniPCI Card	Test By:	Chris Huang
Model Name :	WM68	TEMP&Humidity :	23.9°C , 65%

CH11 TX				Measurement Distance at 1m				Horizontal polarity			
Freq.	Reading	AF	Cable	Pre-amp	Dist	Filter	Level	Limit	Margin	Mark	Height
(MHz)	(dBuV)	(dBuV)	(dB)	(dB)	dB	dB	(dBuV/m)	(dBuV/m)	(dB)	(P/Q/A)	(Meter)
2463.30	79.60	31.74	3.60	0.00	9.50	0.00	105.44	Fundamental Frequency		P	1.00
2463.30	72.71	31.74	3.60	0.00	9.50	0.00	98.55			A	1.00
* 2483.60	29.52	31.72	3.61	0.00	9.50	0.00	55.35	74	-18.65	P	1.00
* 2483.60	17.54	31.72	3.61	0.00	9.50	0.00	43.37	54	-10.63	A	1.00
* 4924.19	46.05	35.10	5.12	35.24	9.50	1.60	43.13	74	-30.87	P	1.00
* 4924.19	36.11	35.10	5.12	35.24	9.50	1.60	33.19	54	-20.81	A	1.00
* 7386.33	45.35	39.75	6.84	35.62	9.50	2.00	48.82	74	-25.18	P	1.00
* 7386.33	33.47	39.75	6.84	35.62	9.50	2.00	36.94	54	-17.06	A	1.00
9847.90	48.76	38.52	8.37	36.76	9.50	0.49	49.88	74	-24.12	P	1.00
9847.90	39.73	38.52	8.37	36.76	9.50	0.49	40.85	54	-13.15	A	1.00
* 12316.50	-----	-----	-----	-----	9.50	0.80	-----	-----	-----	-----	1.00
14779.80	-----	-----	-----	-----	0.00	0.48	-----	-----	-----	-----	1.00
17243.10	-----	-----	-----	-----	0.00	0.60	-----	-----	-----	-----	1.00
* 19706.40	-----	-----	-----	-----	0.00	2.41	-----	-----	-----	-----	1.00

Note :

- The measurement was searched to 10th harmonic, Remark “---” means that the emissions level is too low to be measured.
- AF: Antenna Factor, Cable: Cable Loss, Pre-Amp: Preamplifier gain, Filter: High Pass Filter Insertion Loss (3.5GHz)
- Analyzer setting P(Peak): RBW=1MHz, VBW=1MHz, A(Average): RBW=1MHz, VBW=10Hz
- Remark “*” means the Restricted band.
- Dist : correction to extra plate reading to 3m specification distance 1m measurement distance = -9.5dB
- The result basic equation calculation is as follow:
 $Level = Reading + AF + Cable - Preamp + Filter - Dist$, $Margin = Level - Limit$
- The other emission levels were very low against the limit
- The test limit distance is 3M limit.
- For 802.11b mode at 11Mbps.



Ecom Sertech Corp.

Rm. 258, Bldg. 17, NO.195, Sec. 4 Chung Hsing Rd., ChuTung Chen, Hsinchu, Taiwan 310, R.O.C
 TEL:886-3-5918012 FAX : 886-3-5825720

FCC ID : Q5SWM68-1

Report No. : ER04-05-058FRF

Page 31 of 57

The frequency spectrum above 1 GHz was investigated. All emissions not reported are much lower than the prescribed limits. Readings are both peak and average values.

Company :	Fi Win, Inc.	Test Date :	2004/05/21
Product Name :	54Mbps 802.11g Wireless LAN MiniPCI Card	Test By:	Chris Huang
Model Name :	WM68	TEMP&Humidity :	23.9°C , 65%

CH11 TX				Measurement Distance at 1m				Vertical polarity			
Freq.	Reading	AF	Cable	Pre-amp	Dist	Filter	Level	Limit	Margin	Mark	Height
(MHz)	(dBuV)	(dBuV)	(dB)	(dB)	dB	dB	(dBuV/m)	(dBuV/m)	(dB)	(P/Q/A)	(Meter)
2463.30	78.80	31.74	3.60	0.00	9.50	0.00	104.64	Fundamental Frequency		P	1.00
2463.30	72.00	31.74	3.60	0.00	9.50	0.00	97.84			A	1.00
* 2483.60	29.82	31.72	3.61	0.00	9.50	0.00	55.65	74	-18.35	P	1.00
* 2483.60	17.00	31.72	3.61	0.00	9.50	0.00	42.83	54	-11.17	A	1.00
* 4923.78	46.90	35.10	5.12	35.24	9.50	1.60	43.98	74	-30.02	P	1.00
* 4923.78	37.45	35.10	5.12	35.24	9.50	1.60	34.53	54	-19.47	A	1.00
* 7386.05	44.07	39.75	6.84	35.62	9.50	2.00	47.54	74	-26.46	P	1.00
* 7386.05	32.67	39.75	6.84	35.62	9.50	2.00	36.14	54	-17.86	A	1.00
9847.85	49.67	38.52	8.37	36.76	9.50	0.49	50.79	74	-23.21	P	1.00
9847.85	41.63	38.52	8.37	36.76	9.50	0.49	42.75	54	-11.25	A	1.00
* 12316.50	-----	-----	-----	-----	9.50	0.80	-----	-----	-----	-----	1.00
14779.80	-----	-----	-----	-----	0.00	0.48	-----	-----	-----	-----	1.00
17243.10	-----	-----	-----	-----	0.00	0.60	-----	-----	-----	-----	1.00
* 19706.40	-----	-----	-----	-----	0.00	2.41	-----	-----	-----	-----	1.00

Note :

- The measurement was searched to 10th harmonic, Remark “---” means that the emissions level is too low to be measured.
- AF: Antenna Factor, Cable: Cable Loss, Pre-Amp: Preamplifier gain, Filter: High Pass Filter Insertion Loss (3.5GHz)
- Analyzer setting P(Peak): RBW=1MHz, VBW=1MHz, A(Average): RBW=1MHz, VBW=10Hz
- Remark “*” means the Restricted band.
- Dist : correction to extra plate reading to 3m specification distance 1m measurement distance = -9.5dB
- The result basic equation calculation is as follow:
 $Level = Reading + AF + Cable - Preamp + Filter - Dist$, $Margin = Level - Limit$
- The other emission levels were very low against the limit
- The test limit distance is 3M limit.
- For 802.11b mode at 11Mbps.



Ecom Sertech Corp.

Rm. 258, Bldg. 17, NO.195, Sec. 4 Chung Hsing Rd., ChuTung Chen, Hsinchu, Taiwan 310, R.O.C
 TEL:886-3-5918012 FAX : 886-3-5825720

FCC ID : Q5SWM68-1

Report No. : ER04-05-058FRF

Page 32 of 57

The frequency spectrum above 1 GHz was investigated. All emissions not reported are much lower than the prescribed limits. Readings are both peak and average values.

Company :	Fi Win, Inc.	Test Date :	2004/05/21
Product Name :	54Mbps 802.11g Wireless LAN MiniPCI Card	Test By:	Chris Huang
Model Name :	WM68	TEMP&Humidity :	23.9°C , 65%

CH1 TX				Measurement Distance at 1m					Horizontal polarity			
Freq.	Reading	AF	Cable	Pre-amp	Dist	Filter	Level	Limit	Margin	Mark	Height	
(MHz)	(dBuV)	(dBuV)	(dB)	(dB)	dB	dB	(dBuV/m)	(dBuV/m)	(dB)	(P/Q/A)	(Meter)	
* 2389.90	31.63	31.81	3.57	0.00	9.50	0.00	57.51	74	-16.49	P	1.00	
* 2389.90	17.45	31.81	3.57	0.00	9.50	0.00	43.33	54	-10.67	A	1.00	
2414.25	74.18	31.79	3.58	0.00	9.50	0.00	100.05	Fundamental Frequency		P	1.00	
2414.25	65.50	31.79	3.58	0.00	9.50	0.00	91.37			A	1.00	
* 4823.87	45.87	34.44	5.08	35.16	9.50	2.00	42.74	74	-31.26	P	1.00	
* 4823.87	35.78	34.44	5.08	35.16	9.50	2.00	32.65	54	-21.35	A	1.00	
7236.00	44.50	39.81	6.74	35.65	9.50	2.00	47.89	74	-26.11	P	1.00	
7236.00	33.17	39.81	6.74	35.65	9.50	2.00	36.56	54	-17.44	A	1.00	
9648.00	48.37	38.54	8.29	36.44	9.50	0.61	49.87	74	-24.13	P	1.00	
9648.00	38.57	38.54	8.29	36.44	9.50	0.61	40.07	54	-13.93	A	1.00	
* 12071.25	-----	-----	-----	-----	9.50	0.80	-----	-----	-----	-----	1.00	
* 14485.50	-----	-----	-----	-----	0.00	0.68	-----	-----	-----	-----	1.00	
16899.75	-----	-----	-----	-----	0.00	0.44	-----	-----	-----	-----	1.00	
* 19314.00	-----	-----	-----	-----	0.00	1.98	-----	-----	-----	-----	1.00	
21728.25	-----	-----	-----	-----	0.00	0.81	-----	-----	-----	-----	1.00	
24142.50	-----	-----	-----	-----	0.00	2.87	-----	-----	-----	-----	1.00	

Note :

- The measurement was searched to 10th harmonic, Remark “---” means that the emissions level is too low to be measured.
- AF: Antenna Factor, Cable: Cable Loss, Pre-Amp: Preamplifier gain, Filter: High Pass Filter Insertion Loss (3.5GHz)
- Analyzer setting P(Peak): RBW=1MHz, VBW=1MHz, A(Average): RBW=1MHz, VBW=10Hz
- Remark “*” means the Restricted band.
- Dist : correction to extra plate reading to 3m specification distance 1m measurement distance = -9.5dB
- The result basic equation calculation is as follow:
 $Level = Reading + AF + Cable - Preamp + Filter - Dist$, $Margin = Level - Limit$
- The other emission levels were very low against the limit
- The test limit distance is 3M limit.
- For 802.11g mode at 6Mbps.



Ecom Sertech Corp.

Rm. 258, Bldg. 17, NO.195, Sec. 4 Chung Hsing Rd., ChuTung Chen, Hsinchu, Taiwan 310, R.O.C
 TEL:886-3-5918012 FAX : 886-3-5825720

FCC ID : Q5SWM68-1

Report No. : ER04-05-058FRF

Page 33 of 57

The frequency spectrum above 1 GHz was investigated. All emissions not reported are much lower than the prescribed limits. Readings are both peak and average values.

Company :	Fi Win, Inc.	Test Date :	2004/05/21
Product Name :	54Mbps 802.11g Wireless LAN MiniPCI Card	Test By:	Chris Huang
Model Name :	WM68	TEMP&Humidity :	23.9°C , 65%

CH1 TX				Measurement Distance at 1m				Vertical polarity			
Freq.	Reading	AF	Cable	Pre-amp	Dist	Filter	Level	Limit	Margin	Mark	Height
(MHz)	(dBuV)	(dBuV)	(dB)	(dB)	dB	dB	(dBuV/m)	(dBuV/m)	(dB)	(P/Q/A)	(Meter)
* 2389.90	30.47	31.81	3.57	0.00	9.50	0.00	56.35	74	-17.65	P	1.00
* 2389.90	17.85	31.81	3.57	0.00	9.50	0.00	43.73	54	-10.27	A	1.00
2414.25	73.82	31.79	3.58	0.00	9.50	0.00	99.69	Fundamental Frequency		P	1.00
2414.25	65.64	31.79	3.58	0.00	9.50	0.00	91.51			A	1.00
* 4823.83	50.38	34.44	5.08	35.16	9.50	2.00	47.25	74	-26.75	P	1.00
* 4823.83	38.42	34.44	5.08	35.16	9.50	2.00	35.29	54	-18.71	A	1.00
7235.72	44.96	39.81	6.74	35.65	9.50	2.00	48.35	74	-25.65	P	1.00
7235.72	33.12	39.81	6.74	35.65	9.50	2.00	36.51	54	-17.49	A	1.00
9647.85	48.37	38.54	8.29	36.44	9.50	0.61	49.87	74	-24.13	P	1.00
9647.85	40.07	38.54	8.29	36.44	9.50	0.61	41.57	54	-12.43	A	1.00
* 12071.25	-----	-----	-----	-----	9.50	0.80	-----	-----	-----	-----	1.00
* 14485.50	-----	-----	-----	-----	0.00	0.68	-----	-----	-----	-----	1.00
16899.75	-----	-----	-----	-----	0.00	0.44	-----	-----	-----	-----	1.00
* 19314.00	-----	-----	-----	-----	0.00	1.98	-----	-----	-----	-----	1.00
21728.25	-----	-----	-----	-----	0.00	0.81	-----	-----	-----	-----	1.00
24142.50	-----	-----	-----	-----	0.00	2.87	-----	-----	-----	-----	1.00

Note :

- The measurement was searched to 10th harmonic, Remark “---” means that the emissions level is too low to be measured.
- AF: Antenna Factor, Cable: Cable Loss, Pre-Amp: Preamplifier gain, Filter: High Pass Filter Insertion Loss (3.5GHz)
- Analyzer setting P(Peak): RBW=1MHz, VBW=1MHz, A(Average): RBW=1MHz, VBW=10Hz
- Remark “*” means the Restricted band.
- Dist : correction to extra plate reading to 3m specification distance 1m measurement distance = -9.5dB
- The result basic equation calculation is as follow:
 $Level = Reading + AF + Cable - Preamp + Filter - Dist$, $Margin = Level - Limit$
- The other emission levels were very low against the limit
- The test limit distance is 3M limit.
- For 802.11g mode at 6Mbps.



Ecom Sertech Corp.

Rm. 258, Bldg. 17, NO.195, Sec. 4 Chung Hsing Rd., ChuTung Chen, Hsinchu, Taiwan 310, R.O.C
 TEL:886-3-5918012 FAX : 886-3-5825720

FCC ID : Q5SWM68-1

Report No. : ER04-05-058FRF

Page 34 of 57

The frequency spectrum above 1 GHz was investigated. All emissions not reported are much lower than the prescribed limits. Readings are both peak and average values.

Company :	Fi Win, Inc.	Test Date :	2004/05/21
Product Name :	54Mbps 802.11g Wireless LAN MiniPCI Card	Test By:	Chris Huang
Model Name :	WM68	TEMP&Humidity :	23.9°C , 65%

CH6 TX				Measurement Distance at 1m Horizontal polarity							
Freq.	Reading	AF	Cable	Pre-amp	Dist	Filter	Level	Limit	Margin	Mark	Height
(MHz)	(dBuV)	(dBuV)	(dB)	(dB)	dB	dB	(dBuV/m)	(dBuV/m)	(dB)	(P/Q/A)	(Meter)
2436.89	75.35	31.76	3.59	0.00	9.50	0.00	101.21	Fundamental Frequency		P	1.00
2436.89	67.11	31.76	3.59	0.00	9.50	0.00	92.97			A	1.00
* 4874.08	46.28	34.77	5.10	35.20	9.50	1.80	43.25	74	-30.75	P	1.00
* 4874.08	36.09	34.77	5.10	35.20	9.50	1.80	33.06	54	-20.94	A	1.00
* 7311.77	45.19	39.78	6.79	35.64	9.50	2.00	48.62	74	-25.38	P	1.00
* 7311.77	33.72	39.78	6.79	35.64	9.50	2.00	37.15	54	-16.85	A	1.00
9747.61	47.88	38.53	8.33	36.60	9.50	0.55	49.19	74	-24.81	P	1.00
9747.61	38.07	38.53	8.33	36.60	9.50	0.55	39.38	54	-14.62	A	1.00
* 12184.45	-----	-----	-----	-----	9.50	0.80	-----	-----	-----	-----	1.00
14621.34	-----	-----	-----	-----	0.00	0.60	-----	-----	-----	-----	1.00
17058.23	-----	-----	-----	-----	0.00	0.52	-----	-----	-----	-----	1.00
* 19495.12	-----	-----	-----	-----	0.00	2.19	-----	-----	-----	-----	1.00
21932.01	-----	-----	-----	-----	0.00	0.73	-----	-----	-----	-----	1.00
24368.90	-----	-----	-----	-----	0.00	2.51	-----	-----	-----	-----	1.00

Note :

- The measurement was searched to 10th harmonic, Remark “---” means that the emissions level is too low to be measured.
- AF: Antenna Factor, Cable: Cable Loss, Pre-Amp: Preamplifier gain, Filter: High Pass Filter Insertion Loss (3.5GHz)
- Analyzer setting P(Peak): RBW=1MHz, VBW=1MHz, A(Average): RBW=1MHz, VBW=10Hz
- Remark “*” means the Restricted band.
- Dist : correction to extra plate reading to 3m specification distance 1m measurement distance = -9.5dB
- The result basic equation calculation is as follow:
 $Level = Reading + AF + Cable - Preamp + Filter - Dist$, $Margin = Level - Limit$
- The other emission levels were very low against the limit
- The test limit distance is 3M limit.
- For 802.11g mode at 6Mbps.



Ecom Sertech Corp.

Rm. 258, Bldg. 17, NO.195, Sec. 4 Chung Hsing Rd., ChuTung Chen, Hsinchu, Taiwan 310, R.O.C
 TEL:886-3-5918012 FAX : 886-3-5825720

FCC ID : Q5SWM68-1

Report No. : ER04-05-058FRF

Page 35 of 57

The frequency spectrum above 1 GHz was investigated. All emissions not reported are much lower than the prescribed limits. Readings are both peak and average values.

Company :	Fi Win, Inc.	Test Date :	2004/05/21
Product Name :	54Mbps 802.11g Wireless LAN MiniPCI Card	Test By:	Chris Huang
Model Name :	WM68	TEMP&Humidity :	23.9°C , 65%

CH6 TX				Measurement Distance at 1m				Vertical polarity			
Freq.	Reading	AF	Cable	Pre-amp	Dist	Filter	Level	Limit	Margin	Mark	Height
(MHz)	(dBuV)	(dBuV)	(dB)	(dB)	dB	dB	(dBuV/m)	(dBuV/m)	(dB)	(P/Q/A)	(Meter)
2436.83	74.39	31.76	3.59	0.00	9.50	0.00	100.25	Fundamental Frequency		P	1.00
2436.83	66.82	31.76	3.59	0.00	9.50	0.00	92.68			A	1.00
* 4873.95	50.62	34.77	5.10	35.20	9.50	1.80	47.59	74	-26.41	P	1.00
* 4873.95	39.21	34.77	5.10	35.20	9.50	1.80	36.18	54	-17.82	A	1.00
* 7310.97	45.37	39.78	6.79	35.64	9.50	2.00	48.80	74	-25.20	P	1.00
* 7310.97	33.32	39.78	6.79	35.64	9.50	2.00	36.75	54	-17.25	A	1.00
9747.69	48.66	38.53	8.33	36.60	9.50	0.55	49.97	74	-24.03	P	1.00
9747.69	39.37	38.53	8.33	36.60	9.50	0.55	40.68	54	-13.32	A	1.00
* 12184.15	-----	-----	-----	-----	9.50	0.80	-----	-----	-----	-----	1.00
14620.98	-----	-----	-----	-----	0.00	0.60	-----	-----	-----	-----	1.00
17057.81	-----	-----	-----	-----	0.00	0.52	-----	-----	-----	-----	1.00
* 19494.64	-----	-----	-----	-----	0.00	2.19	-----	-----	-----	-----	1.00
21931.47	-----	-----	-----	-----	0.00	0.73	-----	-----	-----	-----	1.00
24368.30	-----	-----	-----	-----	0.00	2.51	-----	-----	-----	-----	1.00

Note :

- The measurement was searched to 10th harmonic, Remark “---” means that the emissions level is too low to be measured.
- AF: Antenna Factor, Cable: Cable Loss, Pre-Amp: Preamplifier gain, Filter: High Pass Filter Insertion Loss (3.5GHz)
- Analyzer setting P(Peak): RBW=1MHz, VBW=1MHz, A(Average): RBW=1MHz, VBW=10Hz
- Remark “*” means the Restricted band.
- Dist : correction to extra plate reading to 3m specification distance 1m measurement distance = -9.5dB
- The result basic equation calculation is as follow:
 $Level = Reading + AF + Cable - Preamp + Filter - Dist$, $Margin = Level - Limit$
- The other emission levels were very low against the limit
- The test limit distance is 3M limit.
- For 802.11g mode at 6Mbps.



Ecom Sertech Corp.

Rm. 258, Bldg. 17, NO.195, Sec. 4 Chung Hsing Rd., ChuTung Chen, Hsinchu, Taiwan 310, R.O.C
 TEL:886-3-5918012 FAX : 886-3-5825720

FCC ID : Q5SWM68-1

Report No. : ER04-05-058FRF

Page 36 of 57

The frequency spectrum above 1 GHz was investigated. All emissions not reported are much lower than the prescribed limits. Readings are both peak and average values.

Company :	Fi Win, Inc.	Test Date :	2004/05/21
Product Name :	54Mbps 802.11g Wireless LAN MiniPCI Card	Test By:	Chris Huang
Model Name :	WM68	TEMP&Humidity :	23.9°C , 65%

CH11 TX				Measurement Distance at 1m				Horizontal polarity			
Freq.	Reading	AF	Cable	Pre-amp	Dist	Filter	Level	Limit	Margin	Mark	Height
(MHz)	(dBuV)	(dBuV)	(dB)	(dB)	dB	dB	(dBuV/m)	(dBuV/m)	(dB)	(P/Q/A)	(Meter)
2464.15	77.75	31.74	3.60	0.00	9.50	0.00	103.59	Fundamental Frequency		P	1.00
2464.15	69.46	31.74	3.60	0.00	9.50	0.00	95.30			A	1.00
* 2483.60	35.21	31.72	3.61	0.00	9.50	0.00	61.04	74	-12.96	P	1.00
* 2483.60	21.37	31.72	3.61	0.00	9.50	0.00	47.20	54	-6.80	A	1.00
* 4923.46	46.74	35.09	5.12	35.24	9.50	1.61	43.82	74	-30.18	P	1.00
* 4923.46	36.77	35.09	5.12	35.24	9.50	1.61	33.85	54	-20.15	A	1.00
* 7386.02	44.32	39.75	6.84	35.62	9.50	2.00	47.79	74	-26.21	P	1.00
* 7386.02	33.27	39.75	6.84	35.62	9.50	2.00	36.74	54	-17.26	A	1.00
9847.78	48.55	38.52	8.37	36.76	9.50	0.49	49.67	74	-24.33	P	1.00
9847.78	40.37	38.52	8.37	36.76	9.50	0.49	41.49	54	-12.51	A	1.00
* 12320.75	-----	-----	-----	-----	9.50	0.80	-----	-----	-----	-----	1.00
14784.90	-----	-----	-----	-----	0.00	0.47	-----	-----	-----	-----	1.00
17249.05	-----	-----	-----	-----	0.00	0.60	-----	-----	-----	-----	1.00
* 19713.20	-----	-----	-----	-----	0.00	2.41	-----	-----	-----	-----	1.00

Note :

- The measurement was searched to 10th harmonic, Remark “---” means that the emissions level is too low to be measured.
- AF: Antenna Factor, Cable: Cable Loss, Pre-Amp: Preamplifier gain, Filter: High Pass Filter Insertion Loss (3.5GHz)
- Analyzer setting P(Peak): RBW=1MHz, VBW=1MHz, A(Average): RBW=1MHz, VBW=10Hz
- Remark “*” means the Restricted band.
- Dist : correction to extra plate reading to 3m specification distance 1m measurement distance = -9.5dB
- The result basic equation calculation is as follow:
 $Level = Reading + AF + Cable - Preamp + Filter - Dist$, $Margin = Level - Limit$
- The other emission levels were very low against the limit
- The test limit distance is 3M limit.
- For 802.11g mode at 6Mbps.



Ecom Sertech Corp.

Rm. 258, Bldg. 17, NO.195, Sec. 4 Chung Hsing Rd., ChuTung Chen, Hsinchu, Taiwan 310, R.O.C
 TEL:886-3-5918012 FAX : 886-3-5825720

FCC ID : Q5SWM68-1

Report No. : ER04-05-058FRF

Page 37 of 57

The frequency spectrum above 1 GHz was investigated. All emissions not reported are much lower than the prescribed limits. Readings are both peak and average values.

Company :	Fi Win, Inc.	Test Date :	2004/05/21
Product Name :	54Mbps 802.11g Wireless LAN MiniPCI Card	Test By:	Chris Huang
Model Name :	WM68	TEMP&Humidity :	23.9°C , 65%

CH11 TX				Measurement Distance at 1m				Vertical polarity			
Freq.	Reading	AF	Cable	Pre-amp	Dist	Filter	Level	Limit	Margin	Mark	Height
(MHz)	(dBuV)	(dBuV)	(dB)	(dB)	dB	dB	(dBuV/m)	(dBuV/m)	(dB)	(P/Q/A)	(Meter)
2464.20	77.46	31.74	3.60	0.00	9.50	0.00	103.30	Fundamental Frequency		P	1.00
2464.20	69.19	31.74	3.60	0.00	9.50	0.00	95.03			A	1.00
* 2483.60	35.81	31.72	3.61	0.00	9.50	0.00	61.64	74	-12.36	P	1.00
* 2483.60	22.54	31.72	3.61	0.00	9.50	0.00	48.37	54	-5.63	A	1.00
* 4924.73	51.37	35.10	5.12	35.24	9.50	1.60	48.45	74	-25.55	P	1.00
* 4924.73	38.89	35.10	5.12	35.24	9.50	1.60	35.97	54	-18.03	A	1.00
* 7386.11	45.52	39.75	6.84	35.62	9.50	2.00	48.99	74	-25.01	P	1.00
* 7386.11	33.82	39.75	6.84	35.62	9.50	2.00	37.29	54	-16.71	A	1.00
9847.66	49.90	38.52	8.37	36.76	9.50	0.49	51.02	74	-22.98	P	1.00
9847.66	41.82	38.52	8.37	36.76	9.50	0.49	42.94	54	-11.06	A	1.00
* 12321.00	-----	-----	-----	-----	9.50	0.80	-----	-----	-----	-----	1.00
14785.20	-----	-----	-----	-----	0.00	0.47	-----	-----	-----	-----	1.00
17249.40	-----	-----	-----	-----	0.00	0.60	-----	-----	-----	-----	1.00
* 19713.60	-----	-----	-----	-----	0.00	2.41	-----	-----	-----	-----	1.00

Note :

- The measurement was searched to 10th harmonic, Remark “---” means that the emissions level is too low to be measured.
- AF: Antenna Factor, Cable: Cable Loss, Pre-Amp: Preamplifier gain, Filter: High Pass Filter Insertion Loss (3.5GHz)
- Analyzer setting P(Peak): RBW=1MHz, VBW=1MHz, A(Average): RBW=1MHz, VBW=10Hz
- Remark “*” means the Restricted band.
- Dist : correction to extra plate reading to 3m specification distance 1m measurement distance = -9.5dB
- The result basic equation calculation is as follow:
 $Level = Reading + AF + Cable - Preamp + Filter - Dist$, $Margin = Level - Limit$
- The other emission levels were very low against the limit
- The test limit distance is 3M limit.
- For 802.11g mode at 6Mbps.

3.7 Photos of Open Site





Ecom Sertech Corp.

Rm. 258, Bldg. 17, NO.195, Sec. 4 Chung Hsing Rd., ChuTung Chen, Hsinchu, Taiwan 310, R.O.C
TEL:886-3-5918012 FAX : 886-3-5825720

FCC ID : Q5SWM68-1

Report No. : ER04-05-058FRF

Page 39 of 57



4. 6dB BANDWIDTH MEASUREMENT

4.1 Test Equipments

Description & Manufacturer	Model No.	Serial No.	Date Of Calibration
ROHDE & SCHWARZ SPECTRUM ANALYZER	FSEK30	835253/002	June 17, 2003
HP ATTENUATOR	8496B	3247A18505	CAL. ON USE

- Note : 1. The measurement uncertainty is less than +/- 2.6dB, which is calculated as per the NAMAS document NIS81.
2. The calibration interval of the above test instruments is 12 months and the calibrations are traceable to NML/ROC and NIST/USA.

4.2 Test Setup

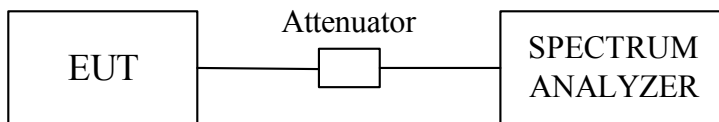

4.3 Limits of 6dB Bandwidth Measurement

The minimum of 6dB Bandwidth Measurement is >500KHz

4.4 Test Procedure

The transmitter output was connected to the spectrum analyzer through an attenuator. The bandwidth of the fundamental frequency was measured by spectrum analyzer with 100 KHz RBW and 10MHz VBW. The 6dB bandwidth is defined as the total spectrum the power of which is higher than peak power minus 6dB.

4.5 Uncertainty of Conducted Emission

The uncertainty of conducted emission is ± 200 KHz.



Ecom Sertech Corp.

Rm. 258, Bldg. 17, NO.195, Sec. 4 Chung Hsing Rd., ChuTung Chen, Hsinchu, Taiwan 310, R.O.C
TEL:886-3-5918012 FAX: 886-3-5825720

FCC ID : Q5SWM68-1

Report No. : ER04-05-058FRF

Page 41 of 57

4.6 Test Results

Input Power (System)	3.3VDC (From PC)	Environmental Conditions	16.4°C, 84%RH
Tested By	Chris Huang		

Channel	Channel Frequency (MHz)	6dB Bandwidth (MHz)	Minimum Limit (MHz)	Pass / Fail
1	2412	12.22	0.5	PASS
6	2437	12.22	0.5	PASS
11	2462	12.22	0.5	PASS

Note: For 802.11b mode.

Channel	Channel Frequency (MHz)	6dB Bandwidth (MHz)	Minimum Limit (MHz)	Pass / Fail
1	2412	16.43	0.5	PASS
6	2437	16.43	0.5	PASS
11	2462	16.43	0.5	PASS

Note: For 802.11g mode.



4.7 Photo of 6db Bandwidth Measurement

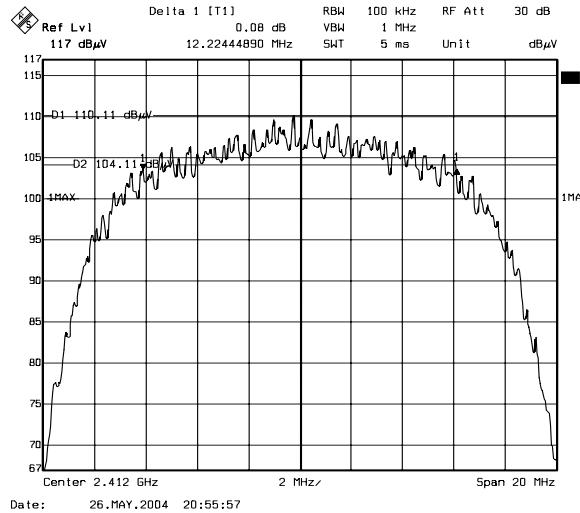

Channel 1

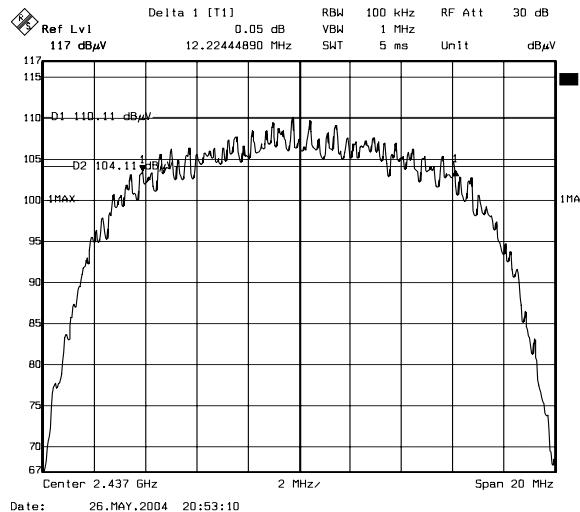

Channel 6

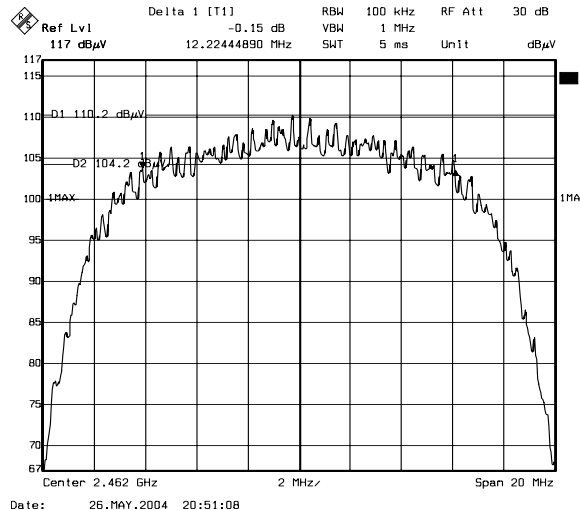

Channel 11

Note: For 802.11b Mode



Ecom Sertech Corp.

Rm. 258, Bldg. 17, NO.195, Sec. 4 Chung Hsing Rd., ChuTung Chen, Hsinchu, Taiwan 310, R.O.C
TEL:886-3-5918012 FAX: 886-3-5825720

FCC ID : Q5SWM68-1

Report No. : ER04-05-058FRF

Page 43 of 57

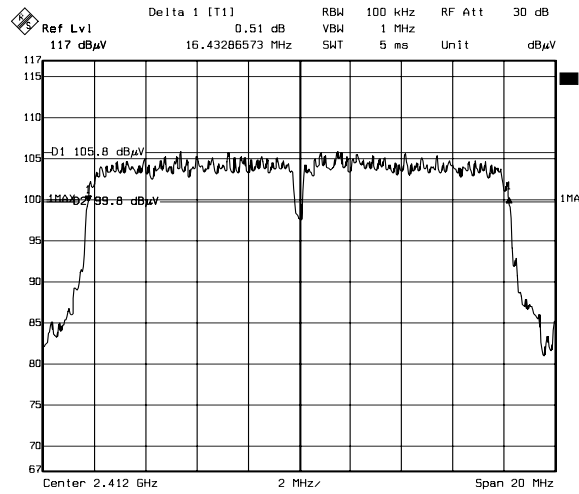

Channel 1

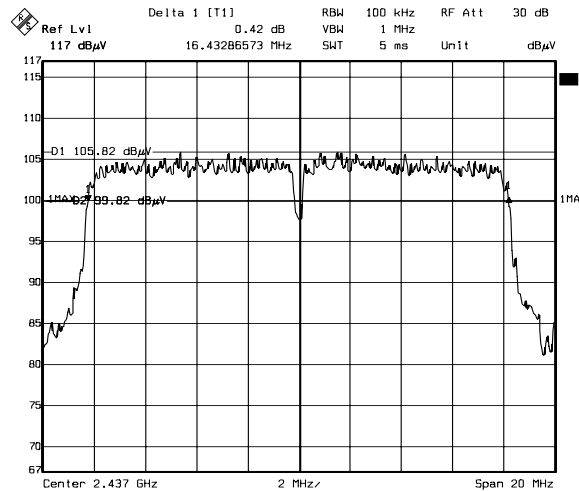

Channel 6

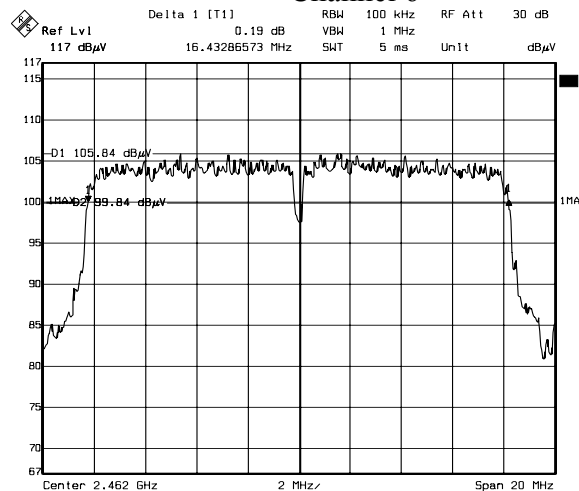

Channel 11

Note: For 802.11g Mode

5. MAXIMUM PEAK OUTPUT POWER

5.1 Test Equipments

Description & Manufacturer	Model No.	Serial No.	Date Of Calibration
ROHDE & SCHWARZ SPECTRUM ANALYZER	FSEK30	835253/002	June 17, 2003
HP ATTENUATOR	8496B	3247A18505	CAL. ON USE
GIGASTRONICS POWER METER	8542	1828329	September 19, 2003

- Note :
1. The measurement uncertainty is less than +/- 2.6dB, which is calculated as per the NAMAS document NIS81.
 2. The calibration interval of the above test instruments is 12 months and the calibrations are traceable to NML/ROC and NIST/USA.

5.2 Test Setup

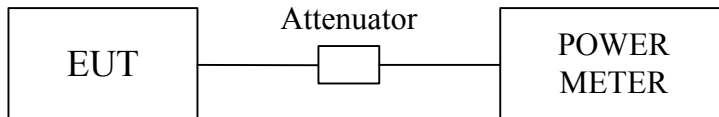

5.3 Limits of Maximum Peak Output Power

The Maximum Peak Output Power Measurement is 30dBm.



5.4 Test Procedure

The RF power output was measured with a Power meter connected to the RF Antenna connector (conducted measurement) while EUT was operating in transmit mode at the appropriate center frequency.

5.5 Uncertainty of Conducted Emission

The uncertainty of conducted emission is $\pm 1.82\text{dB}$.

5.6 Test Results

Input Power (System)	3.3VDC (From PC)	Environmental Conditions	16.4°C, 84%RH
Tested By	Chris Huang		

Channel	Channel Frequency (MHz)	Average Power Output (dBm)	Peak Power Output (dBm)	Peak Power Limit (dBm)	Pass / Fail
1	2412	13.08	15.28	30	PASS
6	2437	13.23	15.40	30	PASS
11	2462	13.29	15.42	30	PASS

Note : 1. For 802.11b mode.

2. At final test to get the worst-case emission at 11Mbps.

3. The results are calculated as the following equation :

$$\text{Peak Power Output} = \text{Peak Power Reading} + \text{Cable loss} + \text{Attenuator}$$

Channel	Channel Frequency (MHz)	Average Power Output (dBm)	Peak Power Output (dBm)	Peak Power Limit (dBm)	Pass / Fail
1	2412	13.01	15.19	30	PASS
6	2437	13.14	15.31	30	PASS
11	2462	13.15	15.36	30	PASS

Note : 1. For 802.11g mode.

2. At final test to get the worst-case emission at 6Mbps.

3. The results are calculated as the following equation :

$$\text{Peak Power Output} = \text{Peak Power Reading} + \text{Cable loss} + \text{Attenuator}$$



6. POWER SPECTRAL DENSITY MEASUREMENT

6.1 Test Equipments

Description & Manufacturer	Model No.	Serial No.	Date Of Calibration
ROHDE & SCHWARZ SPECTRUM ANALYZER	FSEK30	835253/002	June 17, 2003
HP ATTENUATOR	8496B	3247A18505	CAL. ON USE

Note : 1. The measurement uncertainty is less than +/- 2.6dB, which is calculated as per the NAMAS document NIS81.

2. The calibration interval of the above test instruments is 12 months and the calibrations are traceable to NML/ROC and NIST/USA.

6.2 Test Setup

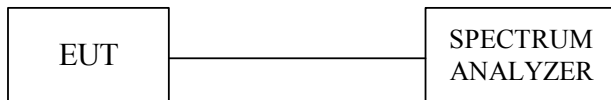

6.3 Limits of Power Spectral Density Measurement

The Maximum Power Spectral Density Measurement is 8dBm/3KHz.



6.4 Test Procedure

The transmitter output was connected to the spectrum analyzer through an attenuator, the bandwidth of the fundamental frequency was measured with the spectrum analyzer using 3KHz RBW and 30KHz VBW, set sweep time=span / 3KHz.

The power spectral density was measured and recorded.

The sweep time is allowed to be longer than span / 3KHz for a full response of the mixer in the spectrum analyzer.

6.5 Uncertainty of Conducted Emission

The uncertainty of conducted emission is ± 1.82 dB.

6.6 Test Results

Input Power (System)	3.3VDC (From PC)	Environmental Conditions	16.4°C, 84%RH
Tested By	Chris Huang		

Channel	Channel Frequency (MHz)	Final RF Power Level in 3KHz BW (dBm)	Maxmum Limit (dBm)	Pass / Fail
1	2412	-11.54	8	PASS
6	2437	-11.58	8	PASS
11	2462	-11.49	8	PASS

Note: For 11Mbps (802.11b mode) at finial test to get the worst-case emission at 11Mbps.

Channel	Channel Frequency (MHz)	Final RF Power Level in 3KHz BW (dBm)	Maxmum Limit (dBm)	Pass / Fail
1	2412	-16.11	8	PASS
6	2437	-16.09	8	PASS
11	2462	-16.14	8	PASS

Note: For 54Mbps (802.11g mode) at finial test to get the worst-case emission at 6Mbps.



6.7 Photo of Power Spectral Density Measurement

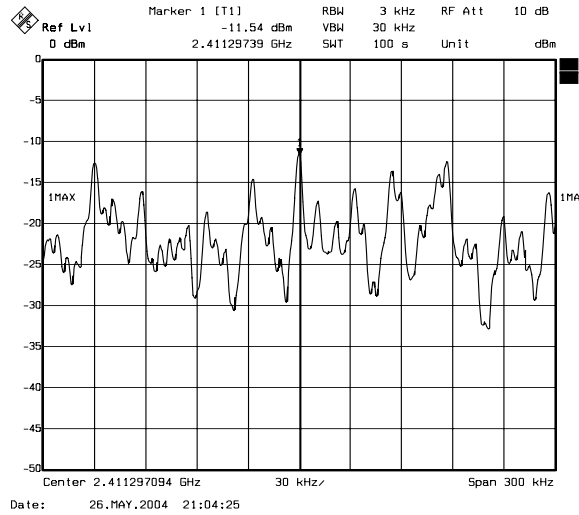

Channel 1

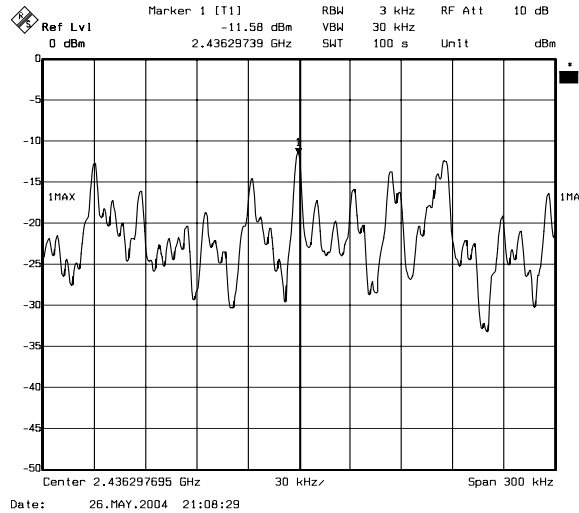

Channel 6

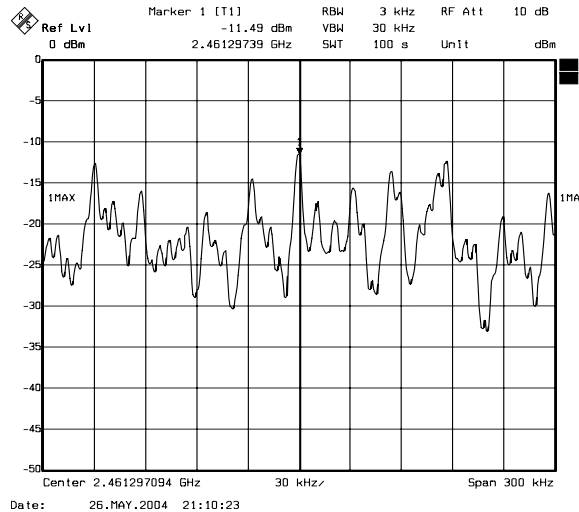

Channel 11

Note: For 802.11b Mode



Ecom Sertech Corp.

Rm. 258, Bldg. 17, NO.195, Sec. 4 Chung Hsing Rd., ChuTung Chen, Hsinchu, Taiwan 310, R.O.C
TEL:886-3-5918012 FAX : 886-3-5825720

FCC ID : Q5SWM68-1

Report No. : ER04-05-058FRF

Page 49 of 57

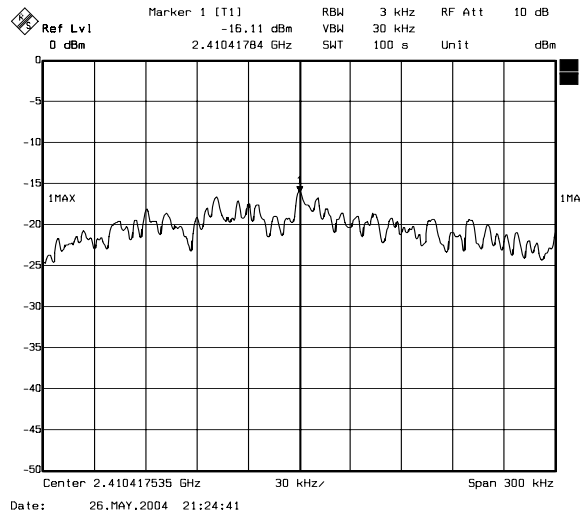

Channel 1

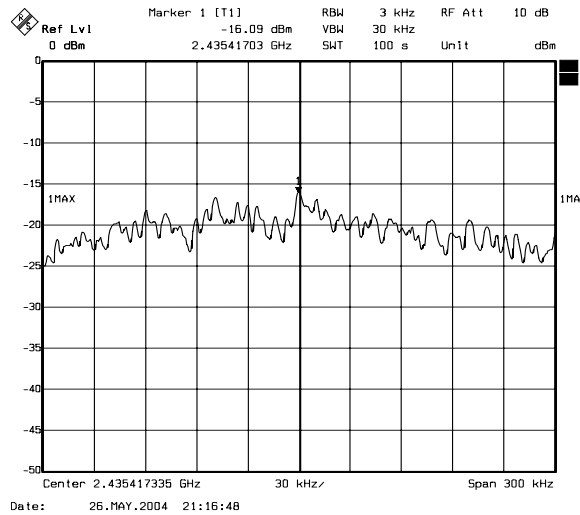

Channel 6

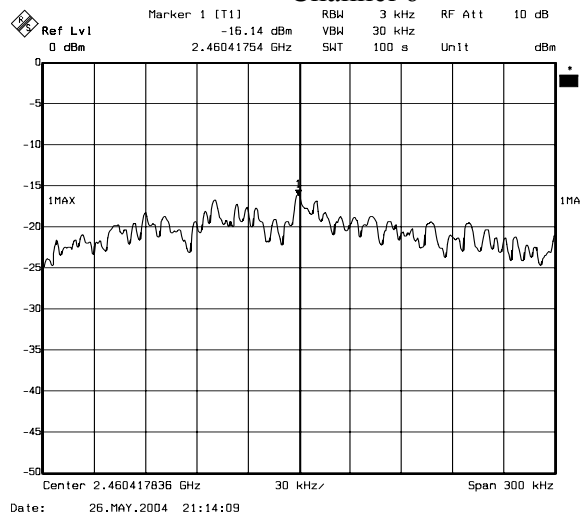

Channel 11

Note: For 802.11g Mode

7. BAND EDGE MEASUREMENT

7.1 Test Equipments

Description & Manufacturer	Model No.	Serial No.	Date Of Calibration
ROHDE & SCHWARZ SPECTRUM ANALYZER	FSEK30	835253/002	June 17, 2003
HP ATTENUATOR	8496B	3247A18505	CAL. ON USE

- Note : 1. The measurement uncertainty is less than +/- 2.6dB, which is calculated as per the NAMAS document NIS81.
2. The calibration interval of the above test instruments is 12 months and the calibrations are traceable to NML/ROC and NIST/USA.

7.2 Test Setup

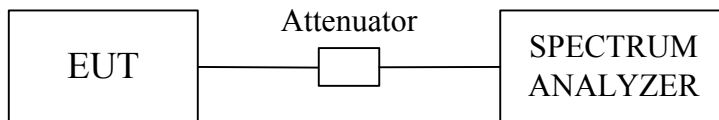

7.3 Limits of Band Edge Emissions Measurement

1. Below -20dB of the highest emission level in operating band.
2. Fall in the restricted bands listed in section 15.205. The maximum permitted average field strength is listed in section 15.209.



7.4 Test Procedure

The transmitter output was connected to the spectrum analyzer via a low lose cable. Set both RBW and VBW of spectrum analyzer with suitable frequency span including 100KHz bandwidth from band edge. The band edges was measured and recorded.

7.5 Uncertainty of Conducted Emission

The uncertainty of conducted emission is $\pm 1.82\text{dB}$.

7.6 Test Results

A. Conducted

Refer to 7.7 photo of band edge Emission measurement

B. Radiated

For 802.11b Mode

Refer to the section 3.6, the measured radiated band edge emissions are listed below :

Input Power (System)	3.3VDC (From PC)	Environmental Conditions	16.4°C, 84%RH
Tested By	Chris Huang		

Band edge		Measured radiated band edge field strength (dBuV/m)		Radiated band edge field strength limit (dBuV/m)		Test result
		Horizontal	Vertical	Horizontal	Vertical	
2399.9	PK	57.92	57.07	83.30	81.68	PASS
	AVG	47.31	46.40	76.51	74.89	
2483.5	PK	55.35	56.11	74.00	74.00	PASS
	AVG	43.46	42.88	54.00	54.00	

Note : Radiated band edge field strength is measured with measurement procedure ANSI C63.4-2001.



Ecom Sertech Corp.

Rm. 258, Bldg. 17, NO.195, Sec. 4 Chung Hsing Rd., ChuTung Chen, Hsinchu, Taiwan 310, R.O.C
 TEL:886-3-5918012 FAX : 886-3-5825720

FCC ID : Q5SWM68-1

Report No. : ER04-05-058FRF

Page 52 of 57

For 802.11g Mode

Refer to the section 3.6, the measured radiated band edge emissions are listed below :

Input Power (System)	3.3DVC (From PC)	Environmental Conditions	16.4°C, 84%RH
Tested By	Chris Huang		

Band edge		Measured radiated band edge field strength (dBuV/m)		Radiated band edge field strength limit (dBuV/m)		Test result
		Horizontal	Vertical	Horizontal	Vertical	
2399.9	PK	71.54	71.13	80.05	79.69	PASS
	AVG	59.57	59.36	71.37	71.51	
2483.5	PK	61.47	62.12	74.00	74.00	PASS
	AVG	47.26	48.09	54.00	54.00	

Note : Radiated band edge field strength is measured with measurement procedure ANSI C63.4-2001.



7.7 Photo of Band edge Measurement

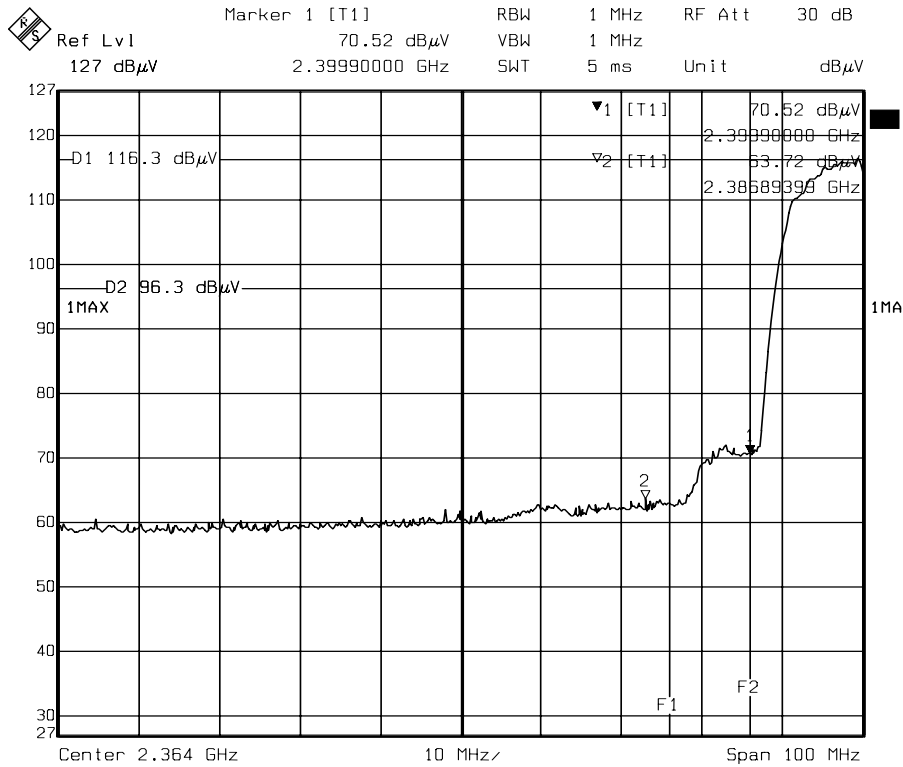

Date: 26.MAY.2004 21:46:25

Lower Band edge (Peak)

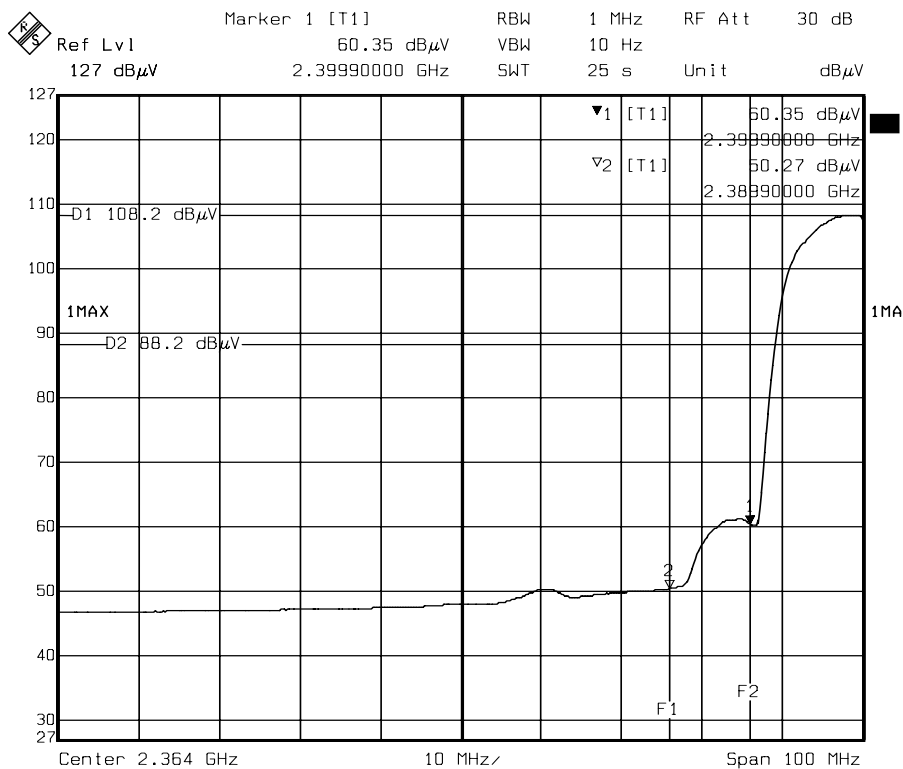

Date: 26.MAY.2004 21:48:52

Lower Band edge (Average)

Note: For 802.11b Mode



Ecom Sertech Corp.

Rm. 258, Bldg. 17, NO.195, Sec. 4 Chung Hsing Rd., ChuTung Chen, Hsinchu, Taiwan 310, R.O.C
 TEL:886-3-5918012 FAX: 886-3-5825720

FCC ID : Q5SWM68-1

Report No. : ER04-05-058FRF

Page 54 of 57

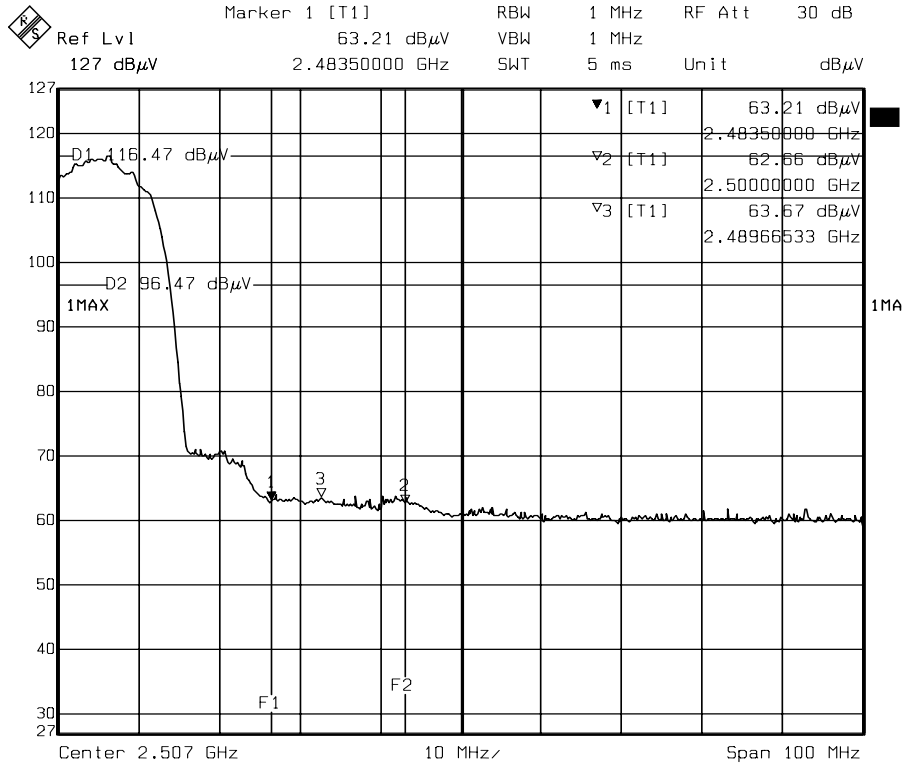

Date: 26.MAY.2004 21:53:09

Higher Band edge (Peak)

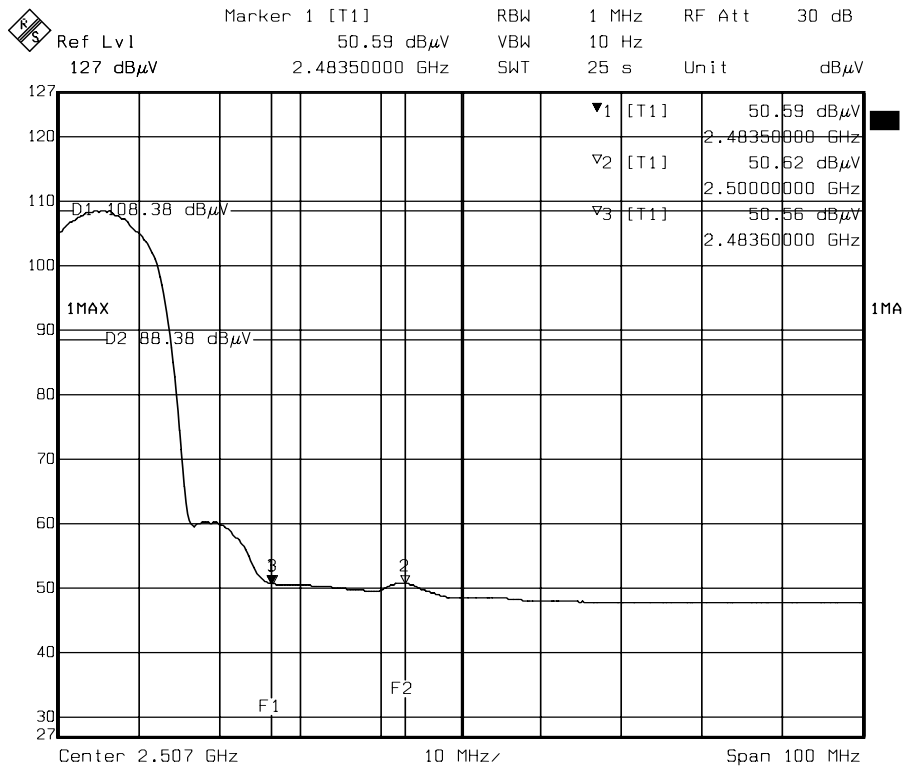

Date: 26.MAY.2004 21:55:26

Higher Band edge (Average)

Note: For 802.11b Mode



Ecom Sertech Corp.

Rm. 258, Bldg. 17, NO.195, Sec. 4 Chung Hsing Rd., ChuTung Chen, Hsinchu, Taiwan 310, R.O.C
TEL:886-3-5918012 FAX: 886-3-5825720

FCC ID : Q5SWM68-1

Report No. : ER04-05-058FRF

Page 55 of 57

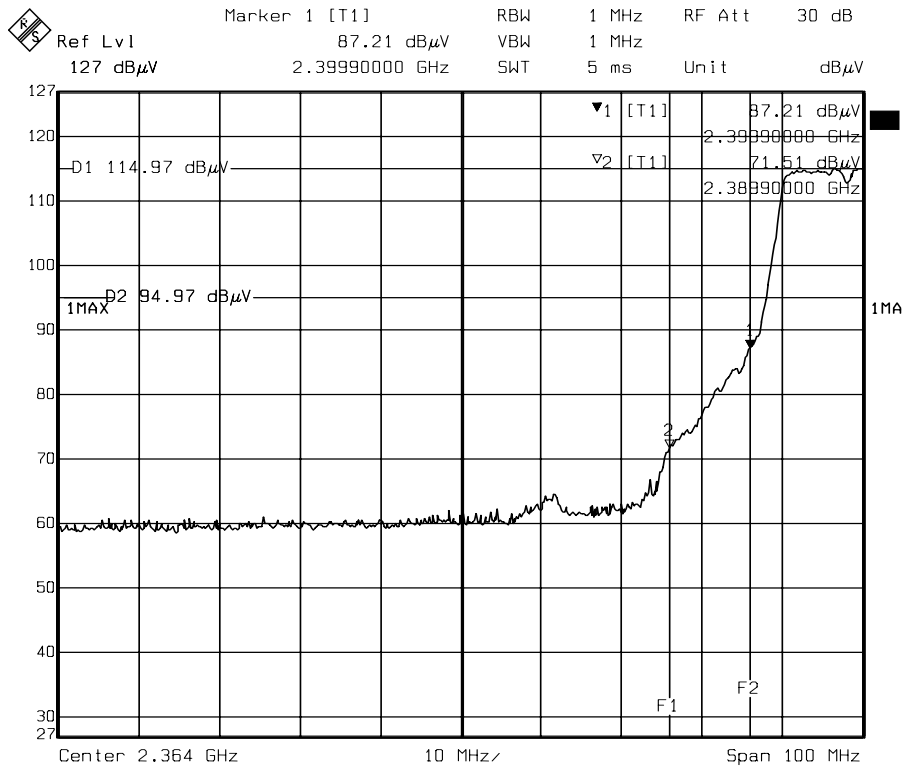

Date: 26.MAY.2004 21:40:15

Lower Band edge (Peak)

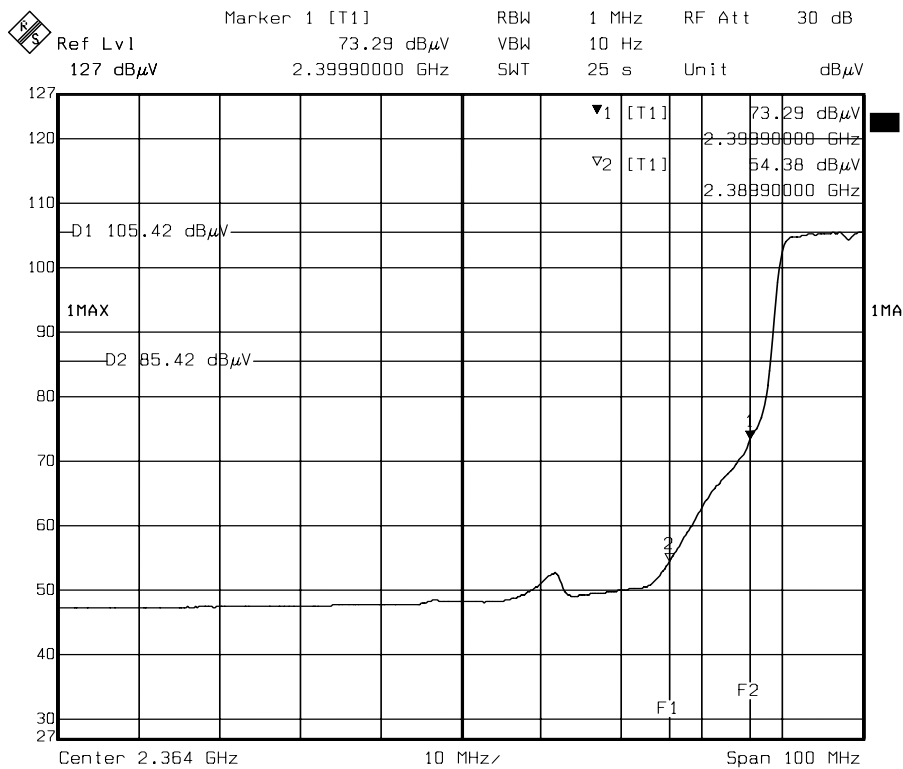

Date: 26.MAY.2004 21:42:02

Lower Band edge (Average)

Note: For 802.11g Mode



Ecom Sertech Corp.

Rm. 258, Bldg. 17, NO.195, Sec. 4 Chung Hsing Rd., ChuTung Chen, Hsinchu, Taiwan 310, R.O.C
 TEL:886-3-5918012 FAX: 886-3-5825720

FCC ID : Q5SWM68-1

Report No. : ER04-05-058FRF

Page 56 of 57

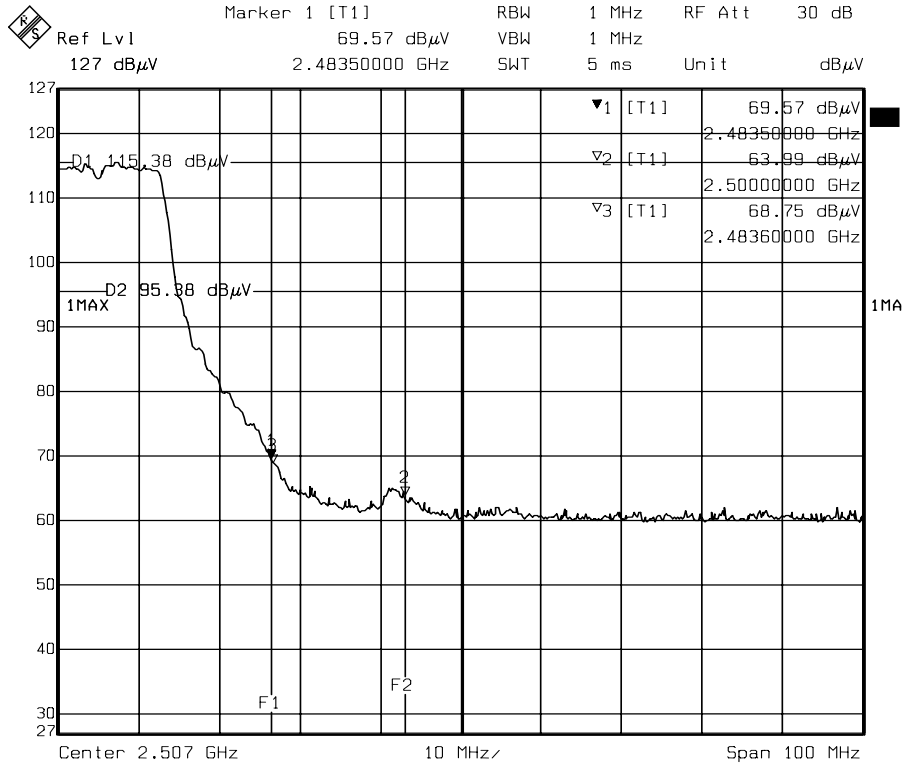

Date: 26.MAY.2004 22:01:03

Higher Band edge (Peak)

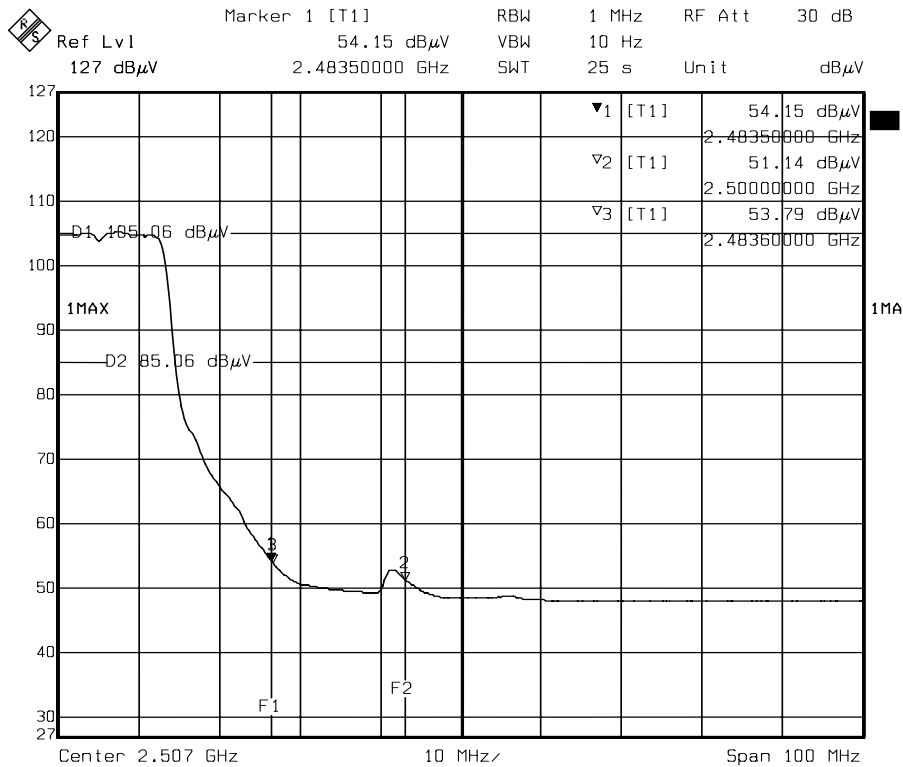

Date: 26.MAY.2004 22:02:44

Higher Band edge (Average)

Note: For 802.11g Mode



8. ANTENNA REQUIREMENT

8.1 Standard Applicable

For intentional device, according to FCC 47 CFR Section 15.203, an intentional radiator shall be designed to ensure that no antenna other than that furnished by the responsible party shall be used with the device.

And according to FCC 47 CFR Section 15.247 (b), if transmitting antennas of directional gain greater than 6dBi are used, the power shall be reduced by the amount in dB that the directional gain of the antenna exceeds 6dBi.

8.2 Antenna Connected Construction

The antenna used in this product is PIFA antenna. The maximum Gain of this antenna is only 2dBi.