

FCC TEST REPORT

CATEGORY : Portable
PRODUCT NAME : Wireless Mouse
FCC ID. : Q5RM3688
FILING TYPE : Certification
BRAND NAME : HAHNTEK
MODEL NAME : M3688

APPLICANT : **HAHNTEK TECHNOLOGY CORP.**
No. 263, Sec. 1, Lung Shou Street, Lu-Chu Hsian 338,
Taoyuan Hsien, Taiwan

MANUFACTURER : **HAHNTEK TECHNOLOGY CORP.**
No. 263, Sec. 1, Lung Shou Street, Lu-Chu Hsian 338,
Taoyuan Hsien, Taiwan

ISSUED BY : **SPORTON INTERNATIONAL INC.**
6F, No. 106, Sec. 1, Hsin Tai Wu Rd., His Chih, Taipei Hsien,
Taiwan, R.O.C.

Statements:

The test result in this report refers exclusively to the presented test model / sample.

Without written approval of SPORTON International Inc., the test report shall not be reproduced except in full.

Certificate or Test Report could not be used by the applicant to claim the product endorsement by CNLA and any agency of U.S. government.

The test equipments used to perform the test are calibrated and traceable to NML/ROC or NIST/USA.



1190
ILAC MRA



Table of Contents

HISTORY OF THIS TEST REPORT	II
CERTIFICATE OF COMPLIANCE.....	III
1. GENERAL DESCRIPTION OF EQUIPMENT UNDER TEST.....	1
1.1. Applicant	1
1.2. Manufacturer	1
1.3. Basic Description of Equipment under Test.....	1
1.4. Features of Equipment under Test	1
1.5. Table for Carrier Frequencies	1
2. TEST CONFIGURATION OF THE EQUIPMENT UNDER TEST	2
2.1. Connection Diagram of Test System	2
2.2. The Test Mode Description	2
2.3. Description of Test Supporting Units	2
3. GENERAL INFORMATION OF TEST	3
3.1. Test Facility	3
3.2. Standards for Methods of Measurement.....	3
3.3. DoC Statement	3
3.4. Frequency Range Investigated	3
3.5. Test Distance	3
3.6. Test Software.....	3
4. LIST OF MEASUREMENTS	4
4.1. Summary of the Test Results.....	4
5. TEST RESULT	5
5.1. Test of Maximum Field Strength of Fundamental	5
5.2. Test of AC Power Line Conducted Emission	7
5.3. Test of Spurious Radiated Emission	13
5.4. Antenna Requirements	17
6. LIST OF MEASURING EQUIPMENTS USED.....	18
7. COMPANY PROFILE.....	19
7.1. Certificate of Accreditation	19
7.2. Test Location	19
8. CNLA CERTIFICATE OF ACCREDITATION.....	20
APPENDIX A. PHOTOGRAPHS OF EUT	A1 ~ A7



HISTORY OF THIS TEST REPORT

Test Date: Mar. 10, 2005

Original Report Issue Date: Mar. 22, 2005

Report No.: F453114

No additional attachment.

Additional attachment were issued as following record:

Attachment No.	Issue Date	Description



CERTIFICATE OF COMPLIANCE

with

47 CFR FCC Part 15 Subpart C

PRODUCT NAME : Wireless Mouse

BRAND NAME : HAHNTEK

MODEL NAME : M3688

APPLICANT : **HAHNTEK TECHNOLOGY CORP.**

No. 263, Sec. 1, Lung Shou Street, Lu-Chu Hsian 338,
Taoyuan Hsien, Taiwan

MANUFACTURER : **HAHNTEK TECHNOLOGY CORP.**

No. 263, Sec. 1, Lung Shou Street, Lu-Chu Hsian 338,
Taoyuan Hsien, Taiwan

I **HEREBY** CERTIFY THAT:

The measurements shown in this test report were made in accordance with the procedures given in ANSI C63.4-2003 and all test are performed according to 47 CFR FCC Part 15 Subpart C. Testing was carried out on Mar. 10, 2005 at SPORTON International Inc. LAB.

A handwritten signature in blue ink, appearing to read 'Wayne Hsu', is written over a horizontal line. Below the line, the name 'Wayne Hsu' is printed in a black, sans-serif font.

Wayne Hsu



1. General Description of Equipment under Test

1.1. Applicant

HAHNTEK TECHNOLOGY CORP.

No. 263, Sec. 1, Lung Shou Street, Lu-Chu Hsian 338, Taoyuan Hsien, Taiwan

1.2. Manufacturer

HAHNTEK TECHNOLOGY CORP.

No. 263, Sec. 1, Lung Shou Street, Lu-Chu Hsian 338, Taoyuan Hsien, Taiwan

1.3. Basic Description of Equipment under Test

The EUT includes Wireless Office Mouse and its receiver with FSK modulation solution. The receiver is used to be plugged on the USB port of the computer. The test report is only for Tx (Mouse). Please refer to "Features of Equipment under Test."

1.4. Features of Equipment under Test

Items	Description
Type of Modulation	FSK
Number of Channels	1
Frequency Band	27.045MHz
Carrier Frequency	See section 1.5 for details
Channel Bandwidth	25kHz
Antenna Type	Printed Ant.
Communication Type	Simplex
Testing Duty Cycle	100.00%
Power Rating (DC/AC, Voltage)	3 VDC from batteries
Temperature Range (Operating)	0 ~ 40 °C

1.5. Table for Carrier Frequencies

Channel	Freq. (MHz)	Channel	Freq. (MHz)	Channel	Freq. (MHz)	Channel	Freq. (MHz)
1	27.045MHz	-	-	-	-	-	-

2. Test Configuration of the Equipment under Test

2.1. Connection Diagram of Test System

Normal Mode



Charging Mode

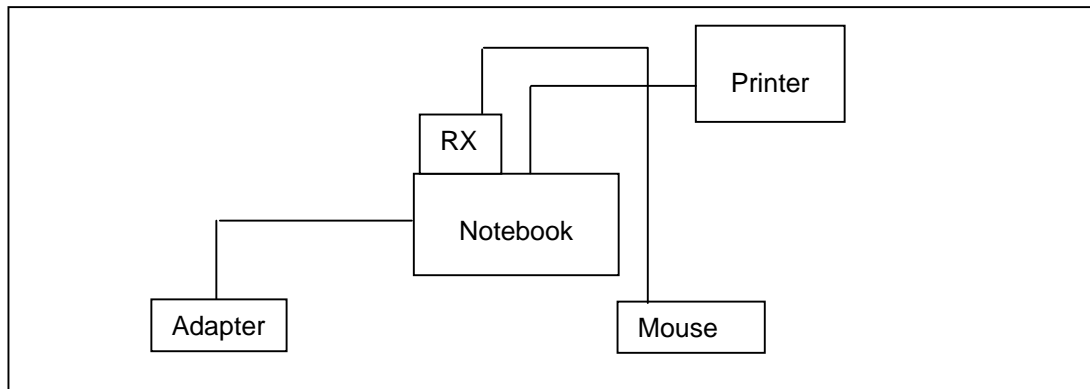

2.2. The Test Mode Description

1. EUT is continuously transmitting data.
2. According to ANSI C63.4-2003: Frequency range of EUT is less than 1 MHz, so we only test 1 channel (27.045MHz) of EUT.
3. There are 2 test modes for this wireless mouse, one is normal function mode, one is charging mode.

2.3. Description of Test Supporting Units

Support unit	Brand	Model No.	Serial No.	FCC ID	Data cable (m)
Notebook	COMPAQ	PRESARIO 1500	NA	Yes	-
Printer	EPSON	STYLUS COLOR 680	NA	Yes	1



3. General Information of Test

3.1. Test Facility

Test Site Location : No. 52, Hwa Ya 1st Rd., Hwa Ya Technology Park, Kwei-Shan Hsiag, Tao Yuan Hsien, Taiwan, R.O.C.
: TEL 886-3-327-3456
: FAX 886-3-318-0055
Test Site No : 03CH03-HY / CO01-HY

3.2. Standards for Methods of Measurement

Here is the list of the standards followed in this test report.

ANSI C63.4-2003

47 CFR FCC Part 15 Subpart C

3.3. DoC Statement

This EUT is also classified as a device of computer peripheral Class B which DoC has to be followed. It has been verified according to the rule of 47 CFR part 15 Subpart B, and found that all the requirements has been fulfilled.

3.4. Frequency Range Investigated

Radiated emission test: from 30 MHz to 10th carrier harmonic

3.5. Test Distance

The test distance of radiated emission (30MHz~1GHz) test from antenna to EUT is 3 M.

The test distance of radiated emission (1GHz~10th carrier harmonic) test from antenna to EUT is 3 M.

3.6. Test Software

During testing, there is no test software for the test.



4. List of Measurements

4.1. Summary of the Test Results

Applied Standard: 47 CFR FCC Part 15 Subpart C			
Paragraph	FCC Section	Description of Test	Result
5.1	15.227(a)	Maximum Field Strength of Fundamental	Pass
5.3	15.207	AC Power Line Conducted Emission	NA
5.2	15.227(b)	Spurious Radiated Emission	Pass
5.4	15.203	Antenna Requirement	Pass

5. Test Result

5.1. Test of Maximum Field Strength of Fundamental

5.1.1. Applicable Standard

Section 15.227(a): The field strength of any emission within this band shall not exceed 10,000 microvolts/meter at 3 meters. The emission limit in this paragraph is based on measurement instrumentation employing an average detector.

5.1.2. Measuring Instruments

Item 6~17 of the table is on section 6.

5.1.3. Description of Major Test Instruments Setting

- Test Receiver : (R&S ESCS 30)
Attenuation : Auto
Center Frequency : Carrier Frequency of EUT
IF Bandwidth : 9 KHz

5.1.4. Test Procedures and Test Instruments Setting

1. Configure the EUT according to ANSI C63.4.
2. The turntable was rotated by 360 degrees to determine the position of the highest radiation.
3. The height of the broadband receiving antenna was varied between one meter and four meters above ground to find the maximum emission field strength of both horizontal and vertical polarization.
4. For carrier field strength emission, the antenna tower was scan (from 1 M to 4 M) and then the turntable was rotated (from 0 degree to 360 degrees) to find the maximum reading.
5. For carrier field strength emission, use 9kHz RBW of Receiver for reading under average and peak detector.

5.1.5. Test Setup Layout

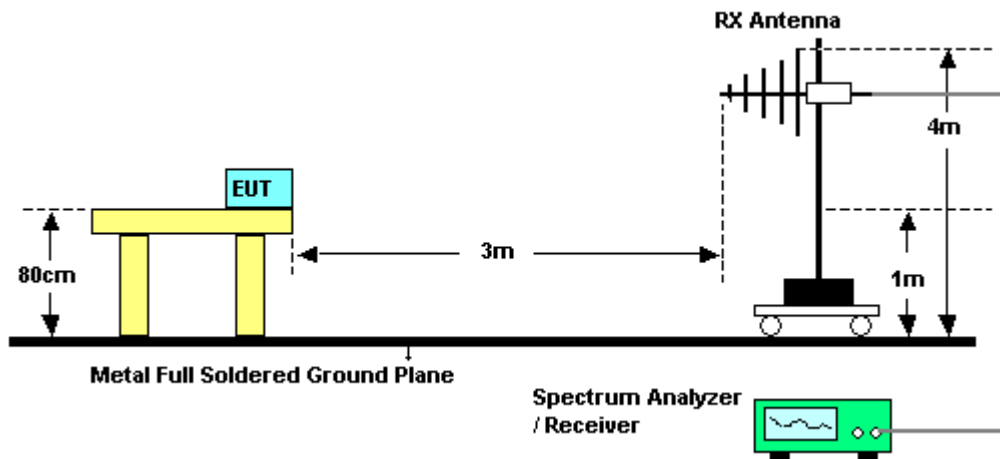



5.1.6. Test Criteria

All test results complied with the requirements of 15.227(a). Measurement Uncertainty is 2.26dB.

5.1.7. Test Result of Maximum Field Strength

- Axis with Maximum Field Strength: X of X, Y, Z axes.
- Temperature: 25°C
- Relative Humidity: 51%
- Duty Cycle of the Equipment During the Test: 100%
- Test Engineer: Ted Chou

Channel No.	Frequency (MHz)	Level (dBuV/m)	Over Limit (dB)	Limit Line (dBuV/m)	Read Level (dBuV/m)	Detector
01	27.045 MHz	45.33	-54.67	100.00	59.92	Peak
01	27.045 MHz	44.45	-35.55	80.00	59.04	Average

Note:

Correct Factor = Antenna Factor + Cable Loss - Preamp Factor.

Read Level = Level of Receiver or Spectrum.

Level = Read Level + Correct Factor.

5.2. Test of AC Power Line Conducted Emission

5.2.1. Applicable Standard

Section 15.207: For a Low-power Radio-frequency Device is designed to be connected to the AC power line, the radio frequency voltage that is conducted back onto the AC power line on any frequency or frequencies within the band 150 kHz to 30 MHz shall not exceed below limits table.

Frequency (MHz)	QP Limit (dBuV)	AV Limit (dBuV)
0.15~0.5	66~56	56~46
0.5~5	56	46
5~30	60	50

5.2.2. Measuring Instruments

Please reference item 1~5 in chapter 6 for the instruments used for testing.

5.2.3. Description of Major Test Instruments Setting

- Test Receiver : R&S ESCS 30
- Attenuation : 10 dB
- Start Frequency : 0.15 MHz
- Stop Frequency : 30 MHz
- IF Bandwidth : 9 KHz

5.2.4. Test Procedures

1. Configure the EUT according to ANSI C63.4.
2. The EUT has to be placed 0.4 meter far from the conducting wall of the shielding room and at least 80 centimeters from any other grounded conducting surface.
3. Connect EUT to the power mains through a line impedance stabilization network (LISN)
4. All the support units are connected to the other LISNs. The LISN should provides 50uH/50ohms coupling impedance.
5. The frequency range from 150 KHz to 30 MHz was searched.
6. Use the Channel & Power Controlling software to make the EUT working on selected channel and expected output power, then use the "H" Patter Generator software to make the supporting equipments stay on working condition.
7. Set the test-receiver system to Peak Detect Function and Specified Bandwidth with Maximum Hold Mode.
8. The measurement has to be done between each power line and ground at the power terminal for each RF channel. Only one RF channel has to be investigated since this test is independent with the RF channel selection.

5.2.5. Test Setup Layout

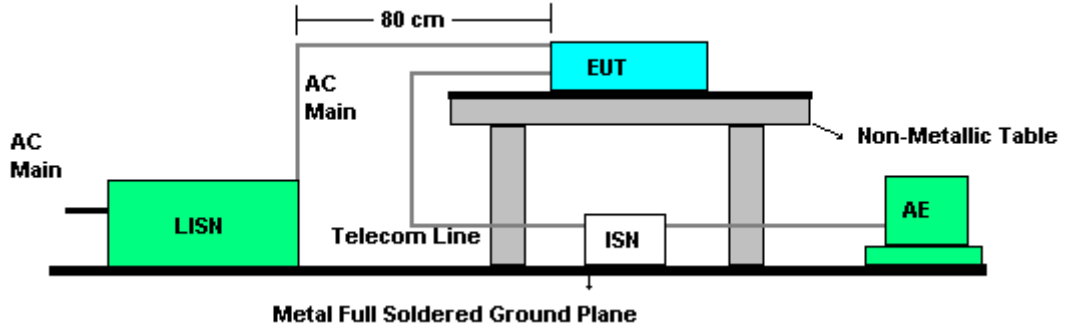

5.2.6. Test Criteria

All test results complied with the requirements of 15.207. Measurement Uncertainty is 2.54dB.



5.2.7. Test Result of Conducted Emission CH 1 / 27.045MHz

- Test Mode: Tx Charging Mode
- Temperature: 23°C
- Relative Humidity: 45%
- Test Engineer: Sky Wu

Line to Ground

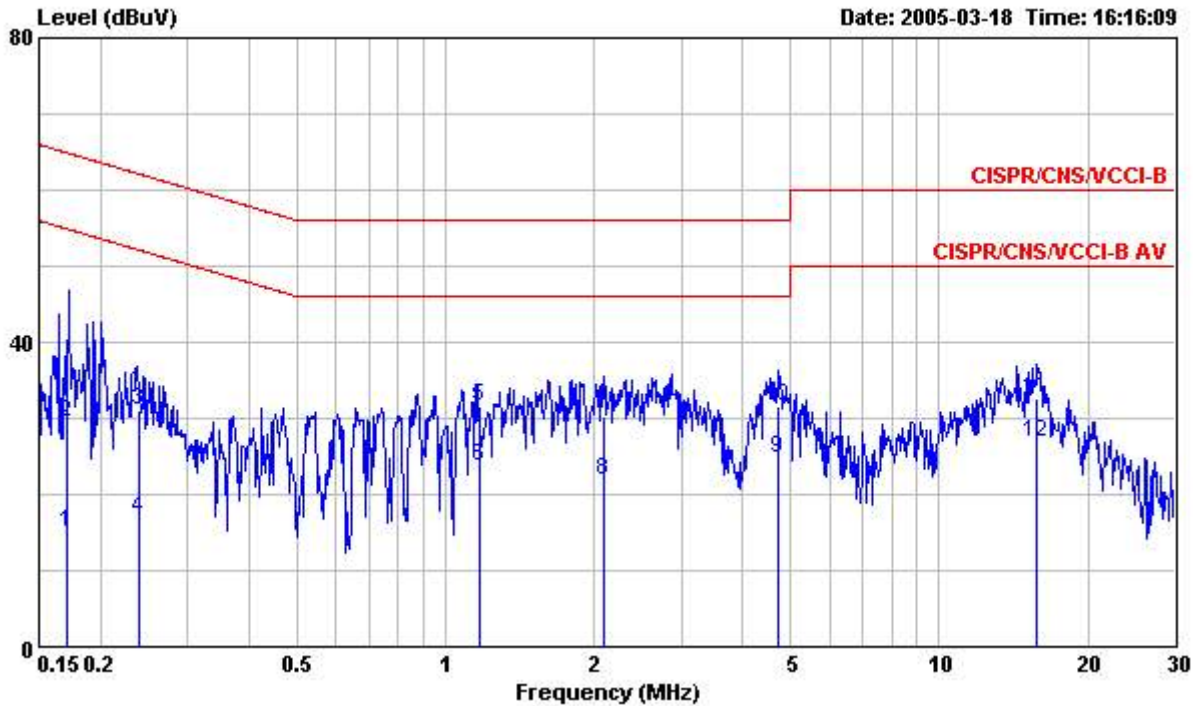

	Freq	Level	Over Limit	Limit Line	Read Level	LISN Factor	Cable Loss	Remark
	MHz	dBuV	dB	dBuV	dBuV	dB	dB	
1	0.1708740	14.91	-40.01	54.92	14.47	0.06	0.38	Average
2	0.1708740	29.60	-35.32	64.92	29.16	0.06	0.38	QP
3	0.2391180	31.13	-31.00	62.13	30.82	0.06	0.25	QP
4	0.2391180	16.88	-35.25	52.13	16.57	0.06	0.25	Average
5	1.171	31.59	-24.41	56.00	30.94	0.11	0.54	QP
6	1.171	23.80	-22.20	46.00	23.15	0.11	0.54	Average
7	2.099	30.24	-25.76	56.00	29.89	0.12	0.23	QP
8	2.099	21.93	-24.07	46.00	21.58	0.12	0.23	Average
9	4.701	24.74	-21.26	46.00	24.25	0.21	0.28	Average
10	4.701	31.63	-24.37	56.00	31.14	0.21	0.28	QP
11	15.799	32.52	-27.48	60.00	31.62	0.23	0.67	QP
12	15.799	26.77	-23.23	50.00	25.87	0.23	0.67	Average



Neutral to Ground

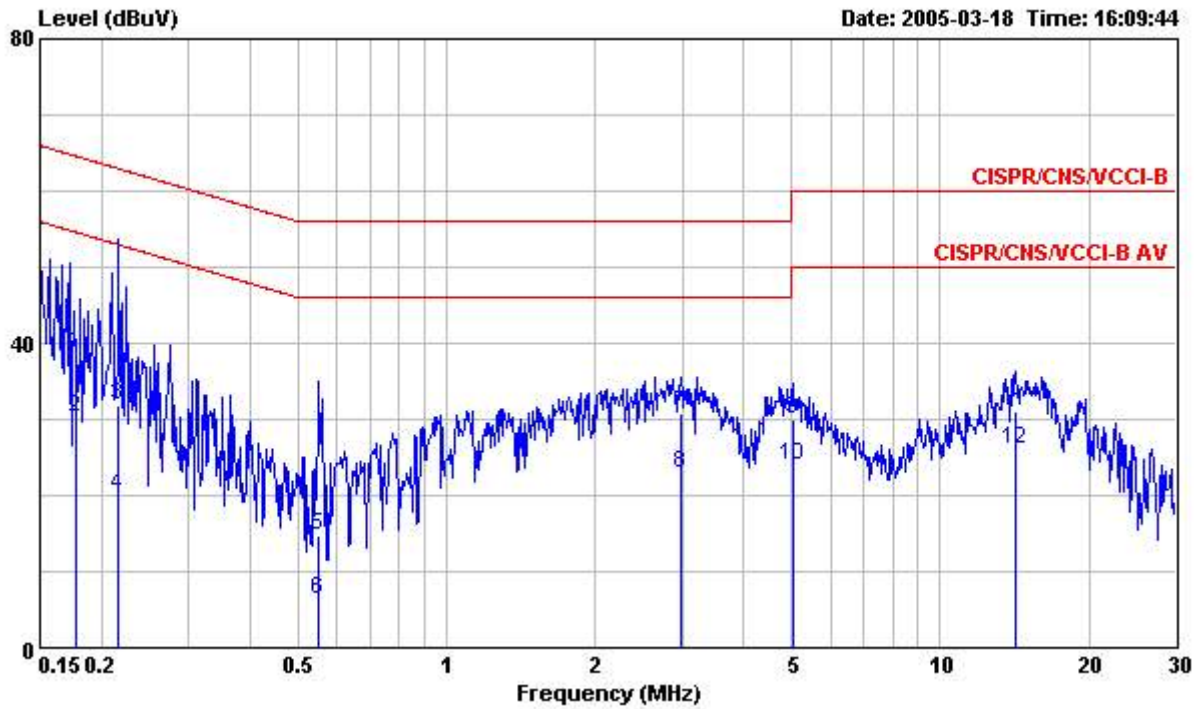

	Freq	Level	Over Limit	Limit Line	Read Level	LISN Factor	Cable Loss	Remark
	MHz	dBuV	dB	dBuV	dBuV	dB	dB	
1	0.1774830	38.64	-25.96	64.60	38.19	0.11	0.34	QP
2	0.1774830	30.31	-24.29	54.60	29.86	0.11	0.34	Average
3	0.2162030	31.87	-31.09	62.96	31.54	0.11	0.22	QP
4	0.2162030	19.90	-33.06	52.96	19.57	0.11	0.22	Average
5	0.5522610	14.68	-41.32	56.00	14.09	0.23	0.36	QP
6	0.5522610	6.43	-39.57	46.00	5.84	0.23	0.36	Average
7	2.978	30.73	-25.27	56.00	30.23	0.23	0.27	QP
8	2.978	23.00	-23.00	46.00	22.50	0.23	0.27	Average
9	5.031	29.87	-30.13	60.00	29.35	0.25	0.27	QP
10	5.031	23.83	-26.17	50.00	23.31	0.25	0.27	Average
11	14.210	31.09	-28.91	60.00	29.63	0.33	1.13	QP
12	14.210	25.94	-24.06	50.00	24.48	0.33	1.13	Average

Note:

Corrected Reading: Probe (LISN / ISN) Factor + Cable Loss + Read Level = Level.

5.2.8. Photographs of Conducted Emission Test Configuration

Normal Mode

FRONT VIEW

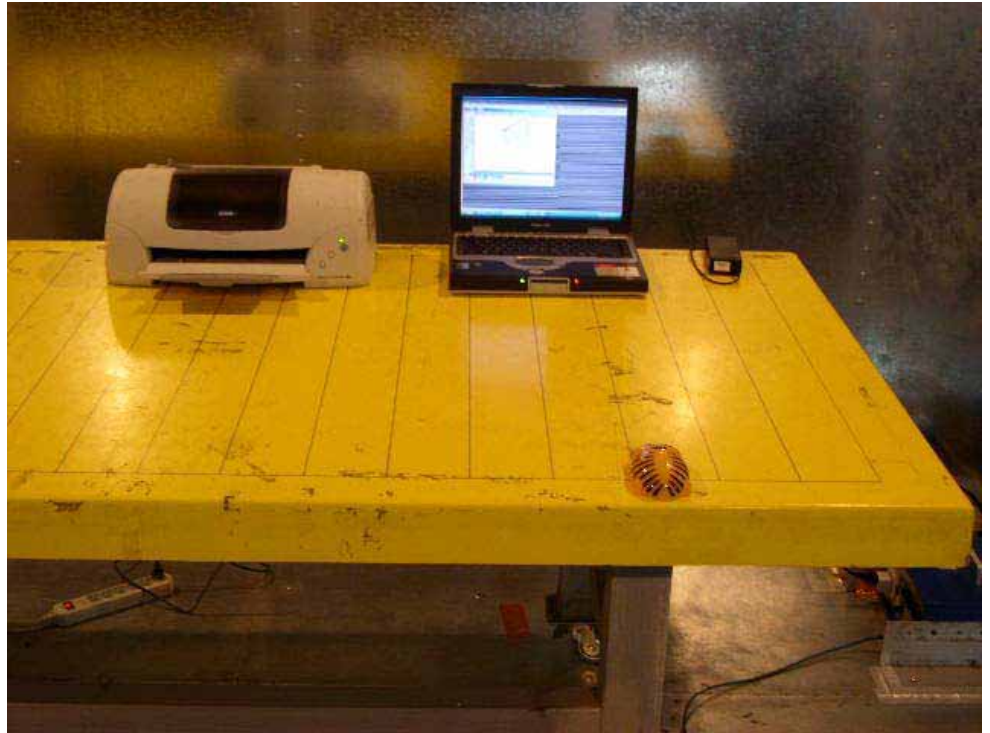

REAR VIEW



Charging Mode

FRONT VIEW



REAR VIEW



5.3. Test of Spurious Radiated Emission

5.3.1. Applicable Standard

Section 15.227(b): The field strength of any emissions which appear outside of this band shall not exceed the general radiated emission limits in Section 15.209.

5.3.2. Measuring Instruments

Please reference item 1~17 in chapter 6 for the instruments used for testing.

5.3.3. Description of Major Test Instruments Setting

- Test Receiver : R&S ESCS 30
- Attenuation : Auto
- Start Frequency : 30 MHz
- Stop Frequency : 10th carrier harmonic
- RB : 120 KHz for QP or PK

5.3.4. Test Procedures

1. Configure the EUT according to ANSI C63.4.
2. The EUT was placed on the top of the turntable 0.8 meter above ground.
3. The phase center of the receiving antenna mounted on the top of a height-variable antenna tower was placed 3 meters far away from the turntable.
4. Power on the EUT and all the supporting units.
5. The turntable was rotated by 360 degrees to determine the position of the highest radiation.
6. The height of the broadband receiving antenna was varied between one meter and four meters above ground to find the maximum emission field strength of both horizontal and vertical polarization.
7. For each suspected emission, the antenna tower was scan (from 1 M to 4 M) and then the turntable was rotated (from 0 degree to 360 degrees) to find the maximum reading.
8. Set the test-receiver system to peak or quasi-peak Detect Function with specified bandwidth under Maximum Hold Mode.

5.3.5. Test Setup Layout

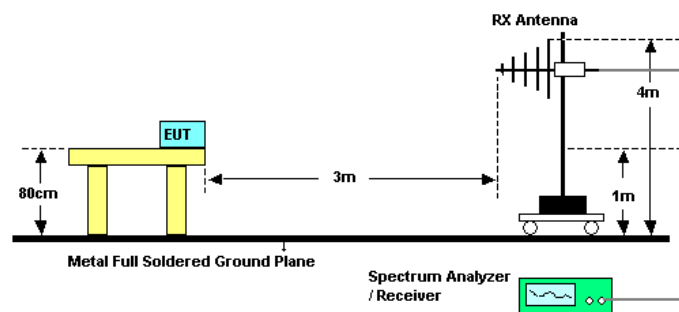

5.3.6. Test Criteria

All test results complied with the requirements of 15.227(b). Measurement Uncertainty is 2.26dB.



5.3.7. Test Results for CH 01 / 27.045 MHz (for emission below 1GHz)

- Temperature: 25°C
- Relative Humidity: 51%
- Duty Cycle of the Equipment During the Test: 100%
- Test Engineer: Ted Chou

(A) Polarization: Horizontal

	Freq	Level	Read Level	Over Limit	Limit	Antenna Line Factor	Cable Loss	Preamp Factor	Remark
	MHz	dBuV/m	dBuV	dB	dBuV/m	dB/m	dB	dB	
1	54.140	28.11	46.62	-11.89	40.00	11.02	0.72	30.25	Peak
2	80.830	27.33	47.03	-12.67	40.00	9.41	0.88	29.99	Peak
3	108.030	22.00	41.21	-21.00	43.00	10.14	1.01	30.36	Peak

	Freq	Level	Read Level	Over Limit	Limit	Antenna Line Factor	Cable Loss	Preamp Factor	Remark
	MHz	dBuV/m	dBuV	dB	dBuV/m	dB/m	dB	dB	
1 @	324.000	38.08	52.44	-7.92	46.00	14.54	1.76	30.66	Peak
2	349.600	37.45	51.20	-8.55	46.00	15.30	1.79	30.84	Peak
3	377.600	26.50	39.63	-19.50	46.00	16.14	1.88	31.15	Peak



(B) Polarization: Vertical

	Freq	Level	Read Level	Over Limit	Limit	Antenna Line Factor	Cable Loss	Preamp Factor	Remark
	MHz	dBuV/m	dBuV	dB	dBuV/m	dB/m	dB	dB	
1	53.630	15.78	34.19	-24.22	40.00	11.07	0.71	30.18	Peak
2	65.020	15.07	34.69	-24.93	40.00	10.14	0.82	30.58	Peak
3	80.830	14.72	34.42	-25.28	40.00	9.41	0.88	29.99	Peak

	Freq	Level	Read Level	Over Limit	Limit	Antenna Line Factor	Cable Loss	Preamp Factor	Remark
	MHz	dBuV/m	dBuV	dB	dBuV/m	dB/m	dB	dB	
1	324.000	32.94	47.30	-13.06	46.00	14.54	1.76	30.66	Peak
2	349.600	32.78	46.53	-13.22	46.00	15.30	1.79	30.84	Peak
3	377.600	22.58	35.71	-23.42	46.00	16.14	1.88	31.15	Peak

Note:

Emission level (dBuV/m) = 20 log Emission level (uV/m)

Corrected Reading: Probe Factor + Cable Loss + Read Level - Preamp Factor = Level

5.3.8. Photographs of Radiated Emission Test Configuration

FRONT VIEW



REAR VIEW





5.4. Antenna Requirements

5.4.1. Standard Applicable

Section 15.203: An intentional radiator shall be designed to ensure that no antenna other than that furnished by the responsible party shall be used with the device. The use of a permanently attached antenna or of an antenna that uses a unique coupling to the intentional radiator shall be considered sufficient to comply with the provisions of this Section. The manufacturer may design the unit so that a broken antenna can be replaced by the user, but the use of a standard antenna jack or electrical connector is prohibited.

5.4.2. Antenna Connected Construction

There is no antenna connector for printed antenna.

5.4.3. Test Criteria

All test results complied with the requirements of 15.203.



6. List of Measuring Equipments Used

Items	Instrument	Manufacturer	Model No.	Serial No.	Characteristics	Calibration Date	Remark
1	EMC Receiver	R&S	ESCS 30	100132	9 KHz – 2.75 GHz	Jun. 23, 2004	Conduction (CO01-HY)
2	LISN	MessTec	NNB-2/16Z	2001/008	9 KHz – 30 MHz	May 03, 2004	Conduction (CO01-HY)
3	LISN (Support Unit)	MessTec	NNB-2/16Z	2001/009	9 KHz – 30 MHz	Apr. 19, 2004	Conduction (CO01-HY)
4	EMI Filter	LINDGREN	LRE-2060	1004	< 450 Hz	N/A	Conduction (CO01-HY)
5	EMI Filter	LINDGREN	N6006	201052	0 ~ 60 Hz	N/A	Conduction (CO01-HY)
6	RF Cable-CON	Suhner Switzerland	RG223/U	CB029	9KHz~30MHz	Dec. 23, 2004	Conduction (CO01-HY)
7	3m Semi Anechoic Chamber	SIDT FRANKONIA	SAC-3M	03CH03-HY	30MHz~1GHz 3m	Jun. 21, 2004	Radiation (03CH03-HY)
8	Spectrum analyzer	R&S	FSP40	100004	9KHZ~40GHZ	Aug. 31, 2004	Radiation (03CH03-HY)
9	Amplifier	HP	8447D	2944A09072	100KHz – 1.3GHz	Nov. 04, 2004	Radiation (03CH03-HY)
10	Biconical Antenna	SCHWARZBECK	VHBB 9124	301	30MHz –200MHz	Jul. 28, 2004	Radiation (03CH03-HY)
11	Log Antenna	SCHWARZBECK	VUSLP 9111	221	200MHz -1GHz	Jul. 28, 2004	Radiation (03CH03-HY)
12	RF Cable-R03m	Jye Bao	RG142	CB021	30MHz~1GHz	Dec. 02, 2004	Radiation (03CH03-HY)
13	Amplifier	MITEQ	AFS44	849984	100MHz~26.5GHz	Mar. 26, 2004	Radiation (03CH03-HY)
14	Horn Antenna	EMCO	3115	6741	1GHz – 18GHz	Apr. 07, 2004	Radiation (03CH03-HY)
15	Turn Table	HD	DS 420	420/650/00	0 ~ 360 degree	N/A	Radiation (03CH03-HY)
16	Antenna Mast	HD	MA 240	240/560/00	1 m - 4 m	N/A	Radiation (03CH03-HY)
17	Horn Antenna	Schwarzbeck	BBHA9170	154	18GHz~40GHz	Jun. 09, 2004	Radiation (03CH03-HY)
18	RF Cable-HIGH	Jye Bao	RG142	CB030-HIGH	1GHz~29.5GHz	Dec. 04, 2004	Radiation (03CH03-HY)

Calibration Interval of instruments listed above is one year.



7. Company Profile

SPORTON Lab. was established in 1986 with one shielded room: the first private EMI test facility, offering local manufacturers an alternative EMI test facility apart from ERSO. In 1988, one 3M and 10M/3M open area test site were setup and also obtained official accreditation from FCC, VCCI and NEMKO. In 1993, a Safety laboratory was founded and obtained accreditation from UL of USA, CSA of Canada and TUV (Rhineland & PS) of Germany. In 1995, one EMC lab, including EMI and EMS test facilities was setup. In 1997, SPORTON Group has provided financial expense to relocate the headquarter to Orient Scientific Park in Taipei Hsien to offer more comprehensive, more qualified and better service to local suppliers and manufactures. In 1999, Safety Group and Component Group were setup. In 2001, SPORTON has established 3M/10M chamber in Hwa Ya Technology Park.

7.1. Certificate of Accreditation

Taiwan	BSMI, CNLA, DGT
USA	FCC, NVLAP, UL
EU	Nemko, TUV
Japan	VCCI
Canada	Industry Canada

7.2. Test Location

SHIJR	ADD : 6Fl., No. 106, Sec. 1, Shintai 5th Rd., Shijr City, Taipei, Taiwan 221, R.O.C. TEL : 02-2696-2468 FAX : 02-2696-2255
HWA YA	ADD : No. 52, Hwa Ya 1st Rd., Hwa Ya Technology Park, Kwei-Shan Hsiang, Tao Yuan Hsien, Taiwan, R.O.C. TEL : 03-327-3456 FAX : 03-318-0055
LINKOU	ADD : No. 30-2, Dingfu Tsuen, Linkou Shiang, Taipei, Taiwan 244, R.O.C TEL : 02-2601-1640 FAX : 02-2601-1695
DUNGHU	ADD : No. 3, Lane 238, Kangle St., Neihu Chiu, Taipei, Taiwan 114, R.O.C. TEL : 02-2631-4739 FAX : 02-2631-9740
JUNGHE	ADD : 7Fl., No. 758, Jungjeng Rd., Junghe City, Taipei, Taiwan 235, R.O.C. TEL : 02-8227-2020 FAX : 02-8227-2626
NEIHU	ADD : 4Fl., No. 339, Hsin Hu 2 nd Rd., Taipei 114, Taiwan, R.O.C. TEL : 02-2794-8886 FAX : 02-2794-9777

8. CNLA Certificate of Accreditation

Test Lab. : Sporton International Inc.
Accreditation Number : 1190
Originally Accredited : 2003/12/15
Effective Period : 2003/12/15~2006/12/14
Accredited Scope : 47 CFR FCC Part 15 Subpart C (9kHz~40GHz)



Taiwan Accreditation Foundation
Chinese National Laboratory Accreditation
Certificate of Accreditation

Accreditation Criteria: ISO 17025
Accreditation Number: 1190
Organization/Laboratory: EMC & Wireless Communications Laboratory, Sporton International Inc.
Originally Accredited: December 15, 2003
Effective Period: December 15, 2003 To December 14, 2006
Accredited Scope: Electrical Testing Field, 7 items, details shown in the following pages.
Specific Accreditation Program: Recognition and Approval of Designated Laboratory for Commodities Inspection

President, Taiwan Accreditation Foundation
Date: July 19, 2004

(This document is invalid unless accompanied by all 4 pages)

CNLA-ZL03191E Page 1 of 4.