

| | | |
|-------|--------------------------------|-----------|
| Title | | |
| Size | Number | Revision |
| A4 | | |
| Date: | 14-May-2003 | Sheet of |
| File: | D:\My Documents\Pcb\M3306U.ddb | Drawn By: |

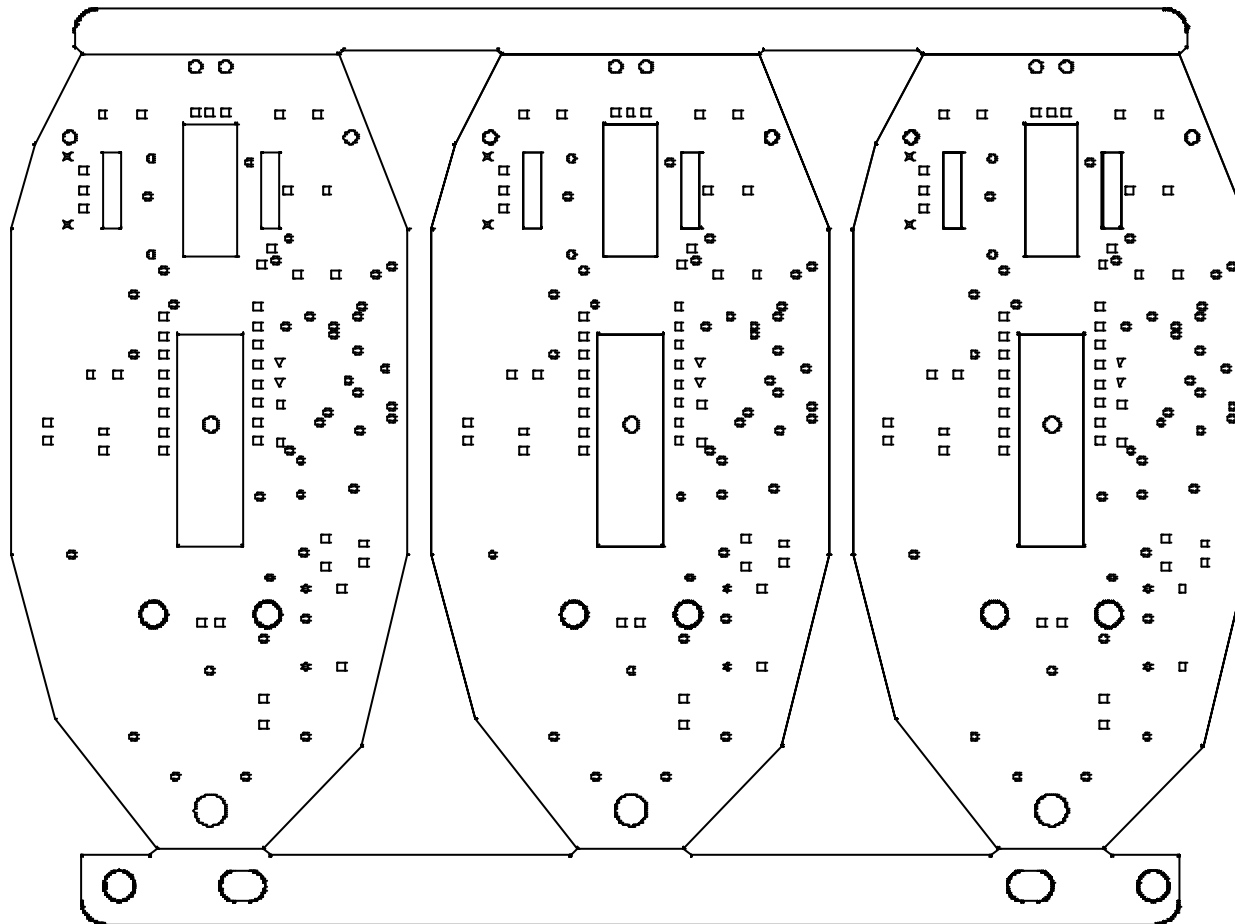

註1. 本圖是由正面所看到的情形
 2. 孔徑如下表所示
 3. 全部的孔都做貫孔

| | | | | |
|---|----|---------|---------|-----|
| □ | 50 | 36.37mm | 1mm | PTH |
| ▽ | 2 | 61.18mm | 1.9mm | PTH |
| ▽ | 2 | 31.49mm | 0.8mm | PTH |
| + | 2 | 30mm | 0.8mm | PTH |
| x | 2 | 80mm | 2.286mm | PTH |
| ● | 40 | 19.05mm | 0.8mm | PTH |
| | 98 | Total | | |

| ITEM | DESCRIPTION | SIGN | DATE | PROJECTION: 3RD ANGLE | DRAW I-HSIUNG 030430 | CHECK | |
|------|-------------|------|------|-----------------------|-------------------------|--------------|-----------|
| 1 | | | | | DESIGN | APRVL | PWB DRILL |
| 2 | | | | FINISH | COLOR | QTY. 1 / SET | MATL |
| 3 | | | | CLIENT CODE | MUS-01 | UNIT | M.M. |
| | | | | | | SCALE | 1:1 |
| | | | | | | PART NO. | 701-1020 |
| | | | | | | PART NAME | M3306-PCB |

PLEASE DON'T SCALE THE DRAWING DIRECTLY

**

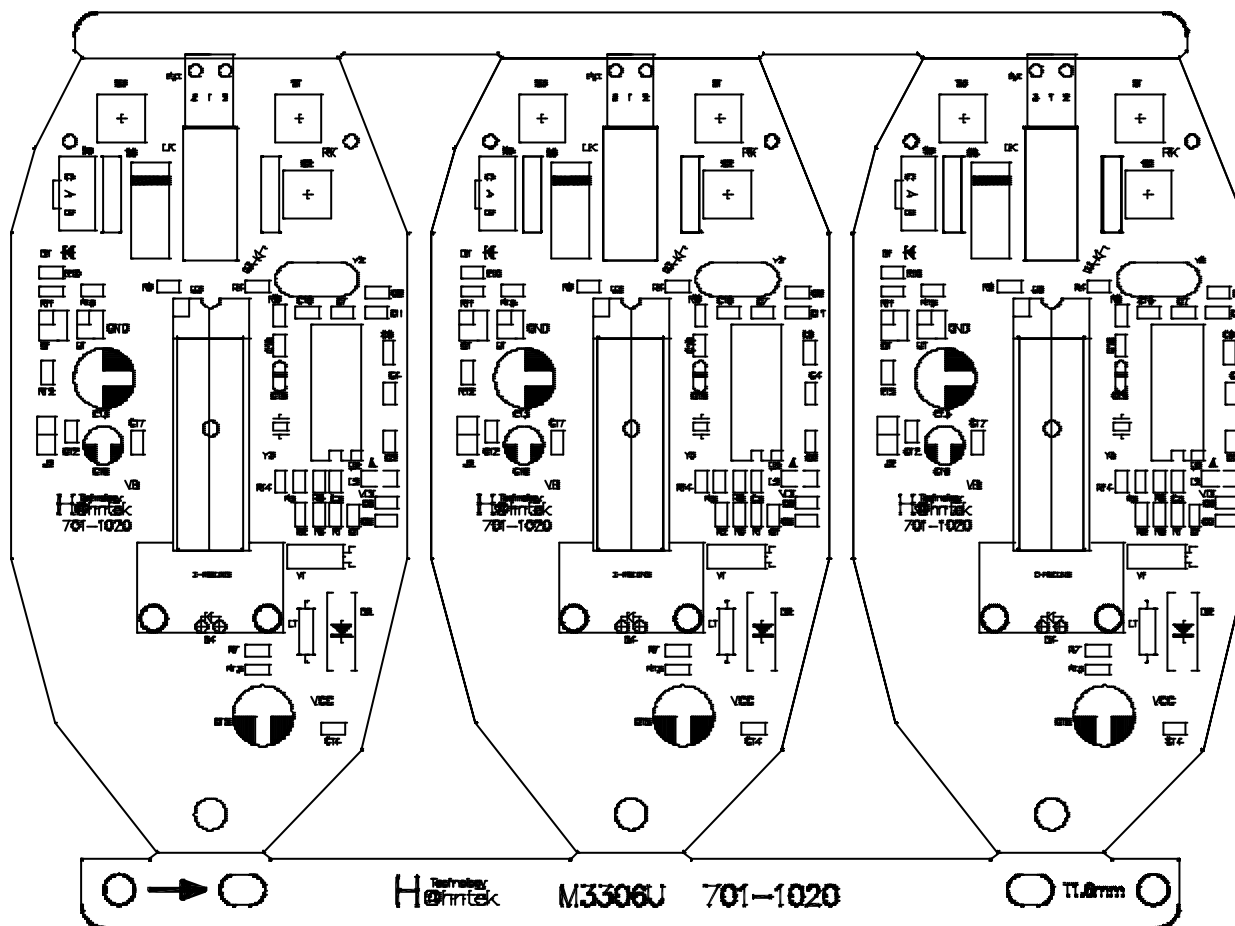

- 註1.本圖是由 A面所看到的情形 .
 2.文字印刷的誤差以線路為基準在 $\pm 0.3\text{mm}$ 以下 .
 3.孔內不可以有油墨侵入 .

PLEASE DON'T SCALE THE DRAWING DIRECTLY **

| ITEM | DESCRIPTION | SIGN | DATE | PROJECTION: 3RD ANGLE | DRAW I-HSIUNG 030430 | CHECK | PWB MARK |
|------|-------------|------|------|-----------------------|-------------------------|--------------|------------------------|
| 1 | | | | | DESIGN | APRVL | |
| 2 | | | | FINISH | COLOR | QTY. 1 / SET | PART NAME M3306-PCB |
| 3 | | | | CLIENT CODE MUS-01 | UNIT M.M. | SCALE 1:1 | PART NO. 701-1020 |

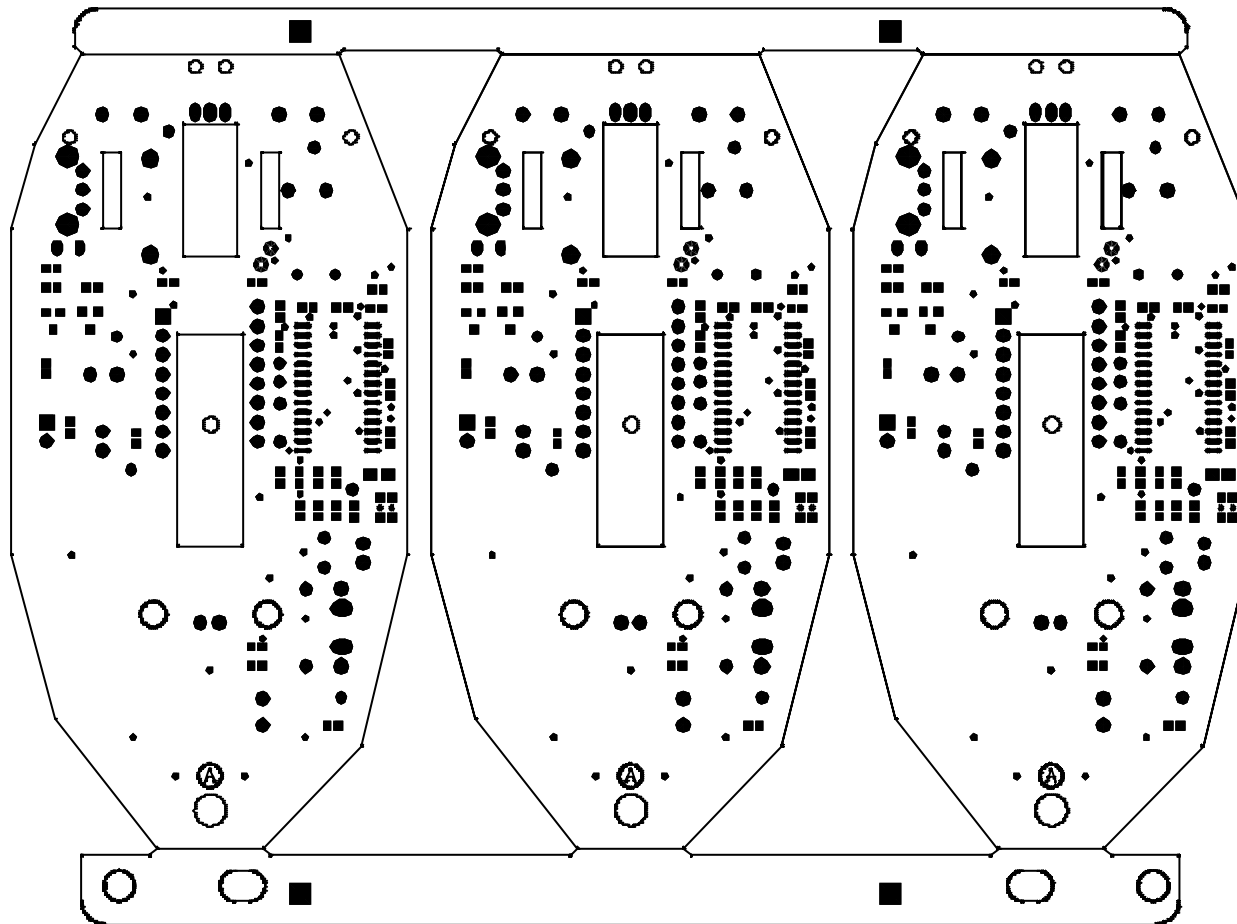

- 註1. 在PWB(903-2022)的A面須做防焊層處理
- 2. 防焊層的誤差以線路為基準在 $\pm 0.1\text{mm}$ 以下
- 3. 本圖塗黑區域以外須做防焊層處理(為綠漆)

PLEASE DON'T SCALE THE DRAWING DIRECTLY **

| ITEM | DESCRIPTION | SIGN | DATE | PROJECTION: 3RD ANGLE | DRAW I-HSIUNG 030430 | CHECK | |
|------|-------------|------|------|-----------------------|-------------------------|--------------|---------------------------|
| 1 | | | | | DESIGN | APRVL | PWB SOLDER SCREEN A SIDE |
| 2 | | | | FINISH | COLOR | QTY. 1 / SET | MATL. PART NAME M3306-PCB |
| 3 | | | | CLIENT CODE MUS-01 | UNIT M.M. | SCALE 1:1 | PART NO. 701-1020 |

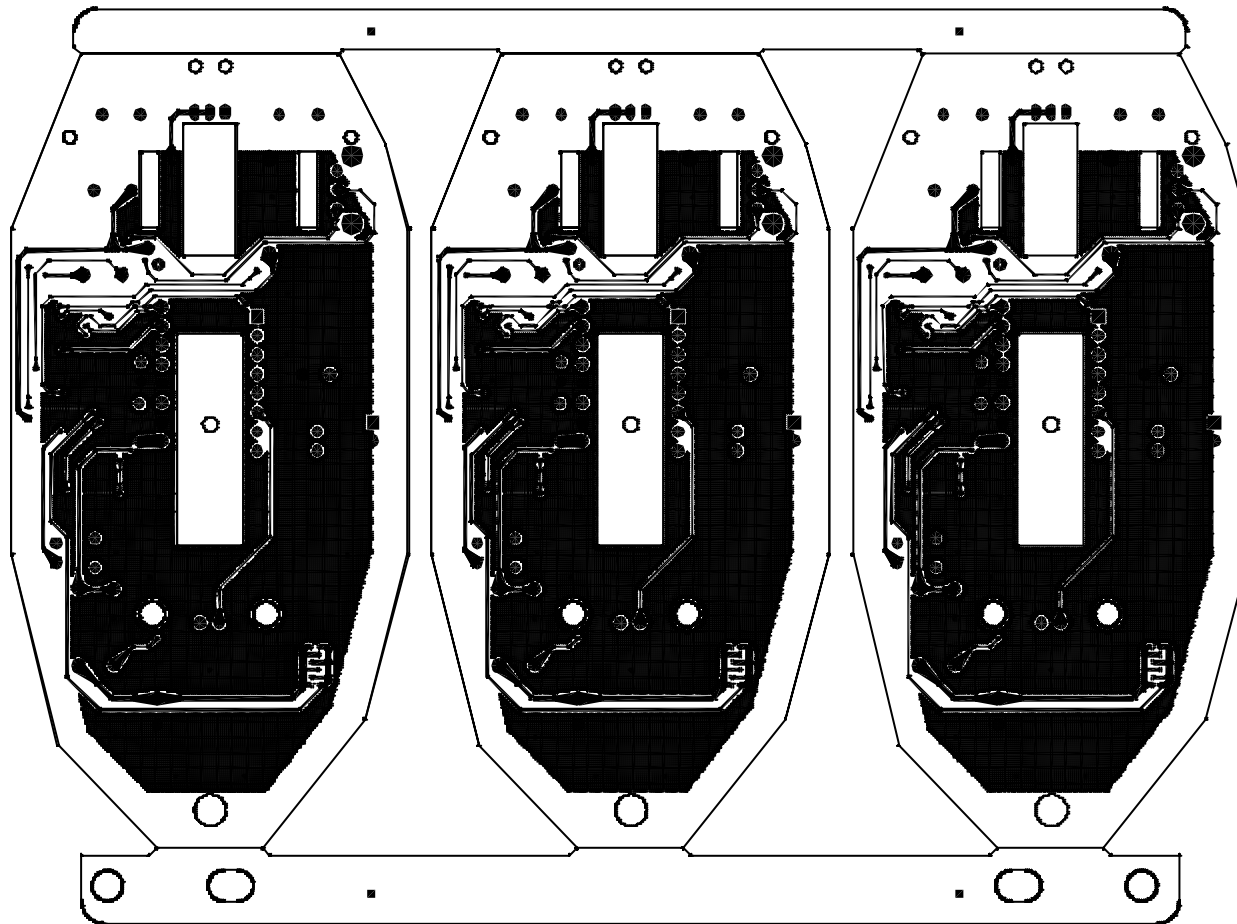

註1. 本圖是由背面所看到的情形

2. 銅箔為鍍金

| ITEM | DESCRIPTION | SIGN. | DATE | PROJECTION: 3RD ANGLE | DRAW I-HSIUNG 030430 | CHECK | PWB PATTERN B SIDE |
|------|-------------|-------|------|-----------------------|-------------------------|--------------|---------------------|
| 1 | | | | | DESIGN | APRVL | |
| 2 | | | | FINISH | COLOR | QTY. 1 / SET | PART NAME M3306-PCB |
| 3 | | | | CLIENT CODE MUS-01 | UNIT M.M. | SCALE 1:1 | PART NO. 701-1020 |

PLEASE DON'T SCALE THE DRAWING DIRECTLY

**

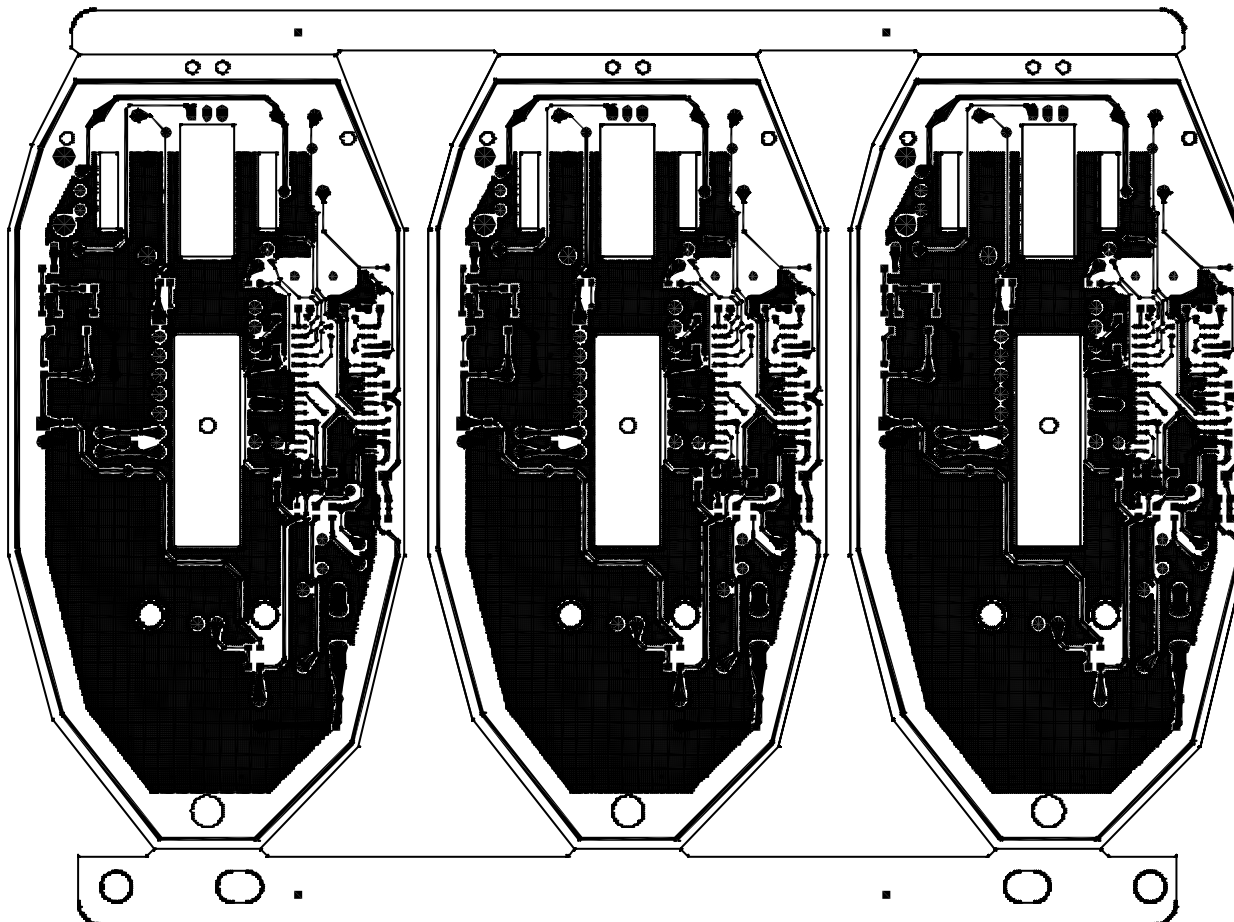

註 1. 本圖是由正面所看到的情形
 2. 銅箔為鍍金

| ITEM | DESCRIPTION | SIGN | DATE | PROJECTION: 3RD ANGLE | DRAW I-HSIUNG 030430 | CHECK | PWB PATTERN A SIDE |
|------|-------------|------|------|-----------------------|-------------------------|--------------|---------------------|
| 1 | | | | | DESIGN | APRVL | |
| 2 | | | | FINISH | COLOR | QTY. 1 / SET | PART NAME M3306-PCB |
| 3 | | | | CLIENT CODE MUS-01 | UNIT M.M. | SCALE 1:1 | PART NO. 701-1020 |

PLEASE DON'T SCALE THE DRAWING DIRECTLY

**

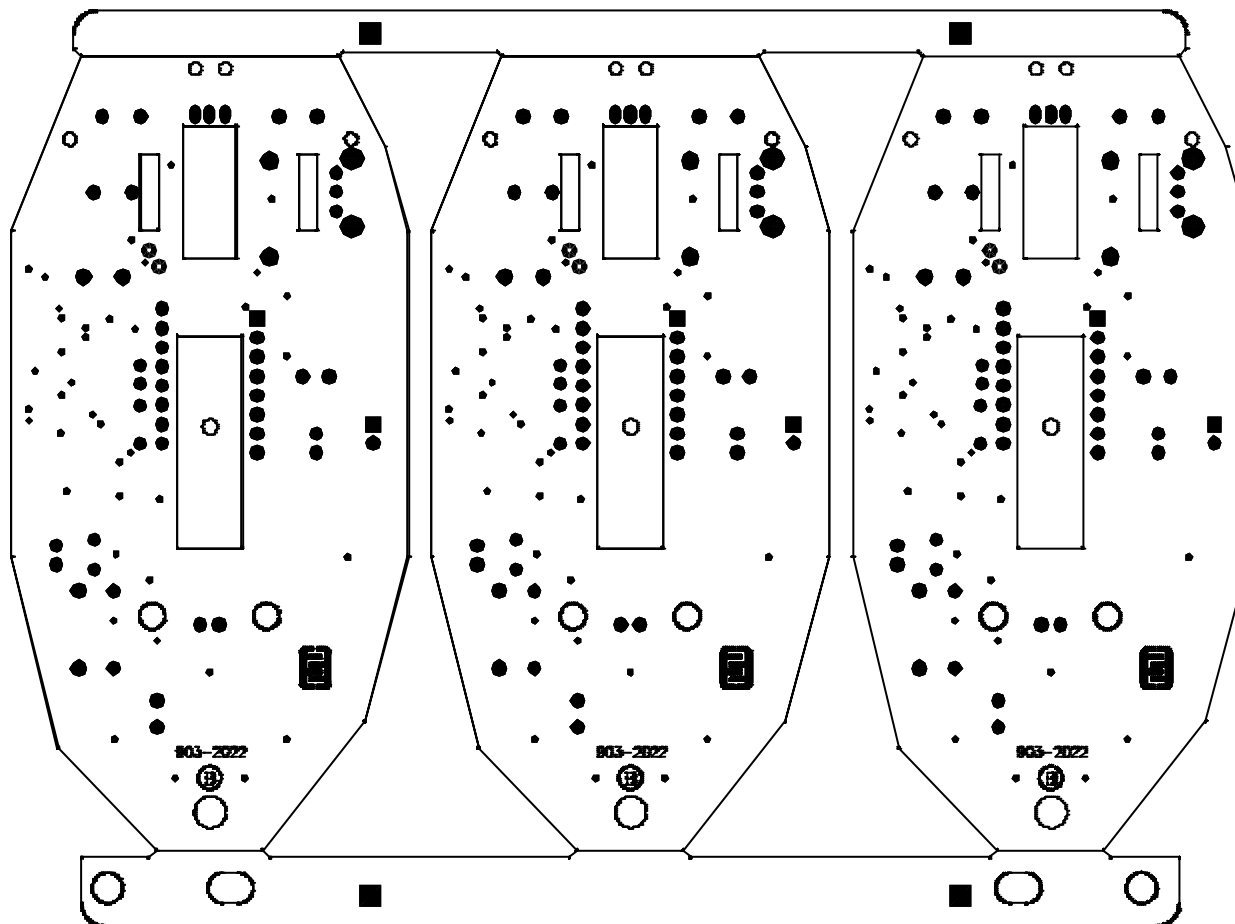

- 註1. 在PWB(903-2022)的B面須做防焊層處理.
 2. 防焊層的誤差以線路為基準在 $\pm 0.1\text{mm}$ 以下.
 3. 本圖塗黑區域以外須做防焊層處理(為綠漆)

| ITEM | DESCRIPTION | SIGN. | DATE | PROJECTION: 3RD ANGLE | DRAW I-HSIUNG 030430 | CHECK | |
|------|-------------|-------|------|-----------------------|-------------------------|--------------|---------------------------|
| 1 | | | | | DESIGN | APRVL | PWB SOLDER SCREEN B SIDE |
| 2 | | | | FINISH | COLOR | QTY. 1 / SET | MATL. PART NAME M3306-PCB |
| 3 | | | | CLIENT CODE MUS-01 | UNIT M.M. | SCALE 1:1 | PART NO. 701-1020 |

PLEASE DON'T SCALE THE DRAWING DIRECTLY

**