

Title		
Size A4	Number	Revision
Date: 14-May-2003	Sheet of	
File: D:\My Documents\Pcb\M3106.ddb	Drawn By:	

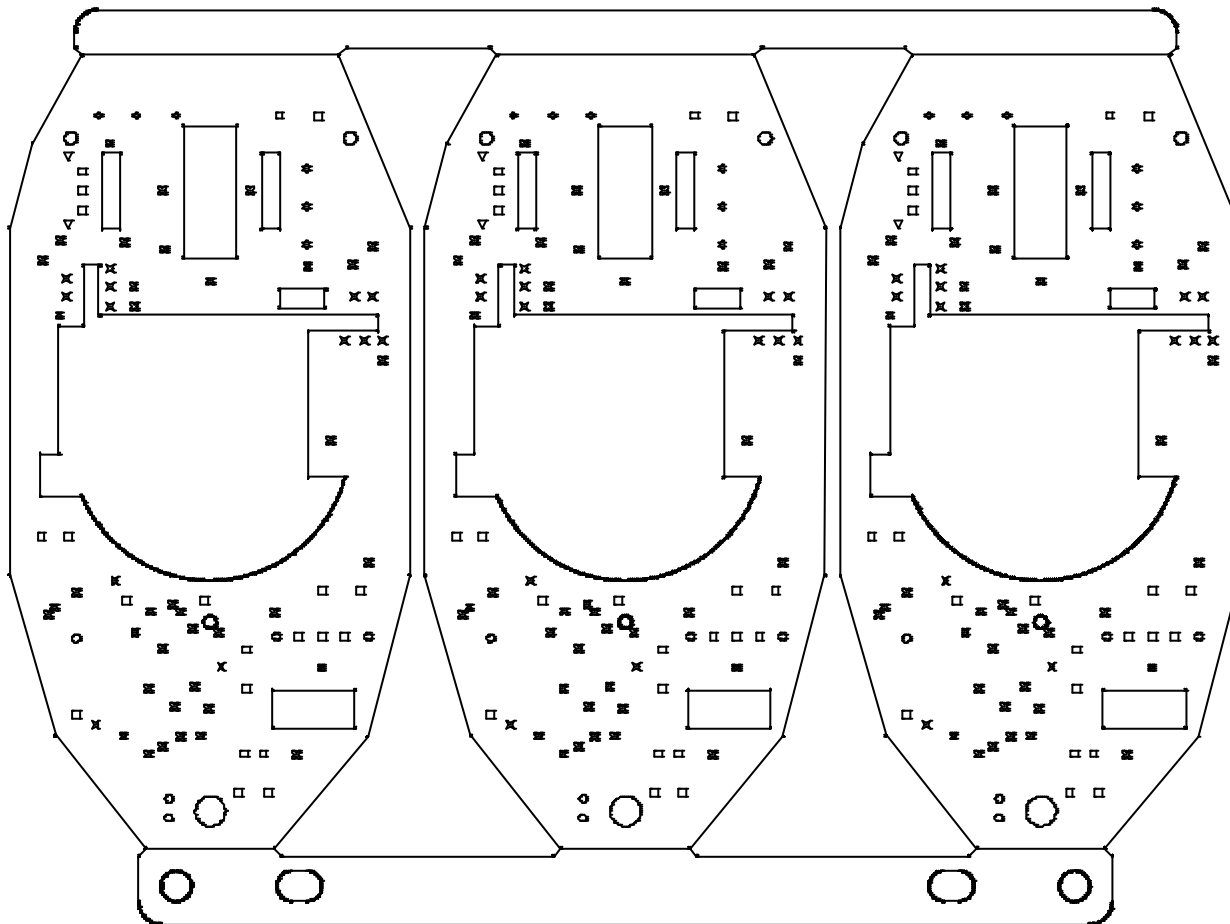

- 註1. 本圖是由正面所看到的情形  
 2. 孔徑如下表所示  
 3. 全部的孔都做貫孔

□	21	39.37mil	1mm	PTH
○	3	36.433mil	0.9mm	PTH
▽	2	80mil	2.286mm	PTH
+	6	43.307mil	1.1mm	PTH
e	13	31.486mil	0.8mm	PTH
e	2	47.244mil	1.2mm	PTH
e	39	19.685mil	0.5mm	PTH
Σ		Total		

ITEM	DESCRIPTION	SIGN.	DATE	PROJECTION: 3RD ANGLE	DRAW I-HSIUNG 030426	CHECK	PWB DRILL
1					DESIGN	APRVL	
2				FINISH	QTY. 1 / SET	MATL	
3				CLIENT CODE MUS-01	UNIT M.M.	SCALE 1:1	PART NAME M3106-PCB PART NO. 701-1013

PLEASE DON'T SCALE THE DRAWING DIRECTLY

\*\*

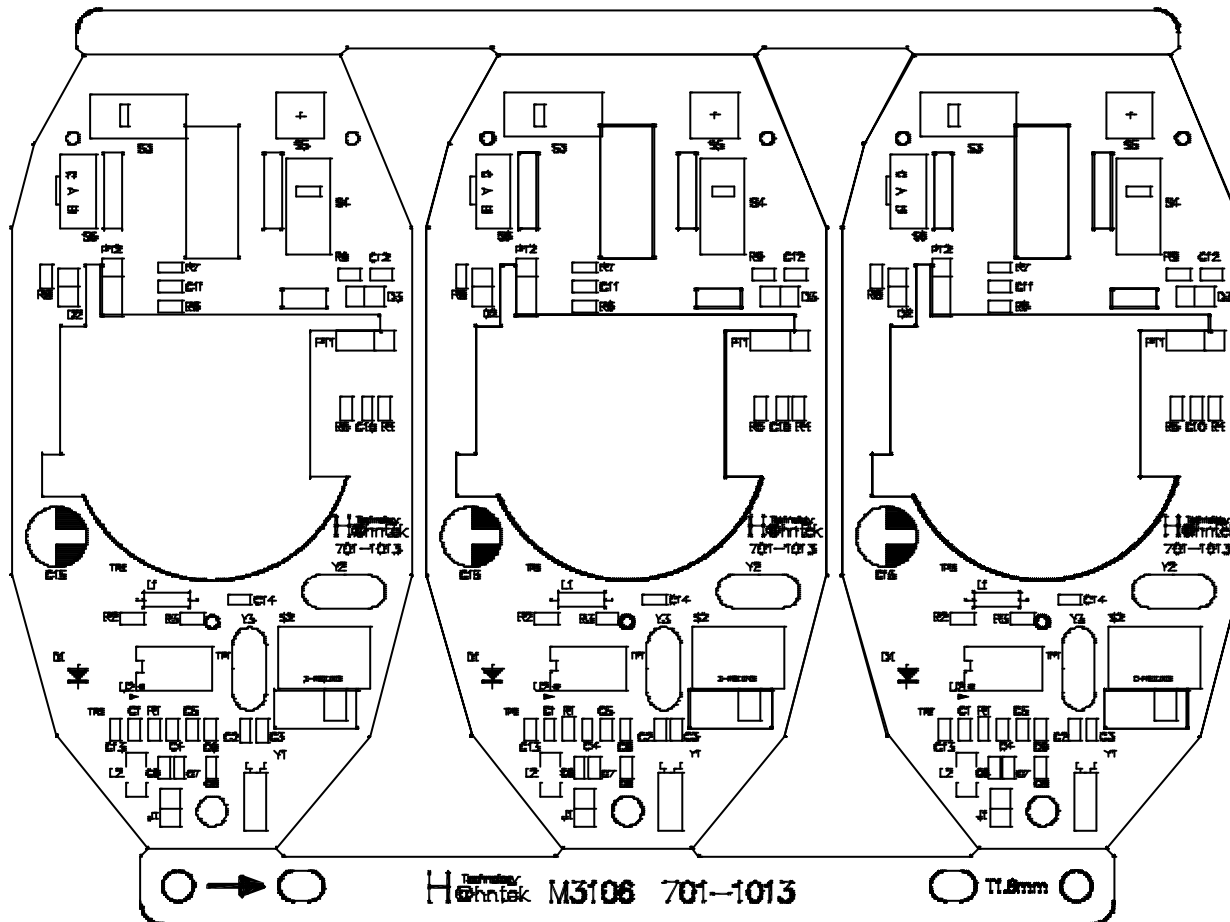

- 註1.本圖是由 A面所看到的情形 .  
 2.文字印刷的誤差以線路為基準在  $\pm 0.3\text{mm}$  以下 .  
 3.孔內不可以有油墨侵入 .

ITEM	DESCRIPTION	SIGN.	DATE	PROJECTION: 3RD ANGLE	DRAW I-HSIUNG 030426	CHECK	PWB MARK
1					DESIGN	APRVL	
2				FINISH	COLOR	QTY. 1 / SET	PART NAME M3106-PCB
3				CLIENT CODE MUS-01	UNIT M.M.	SCALE 1:1	PART NO. 701-1013

PLEASE DON'T SCALE THE DRAWING DIRECTLY

\*\*

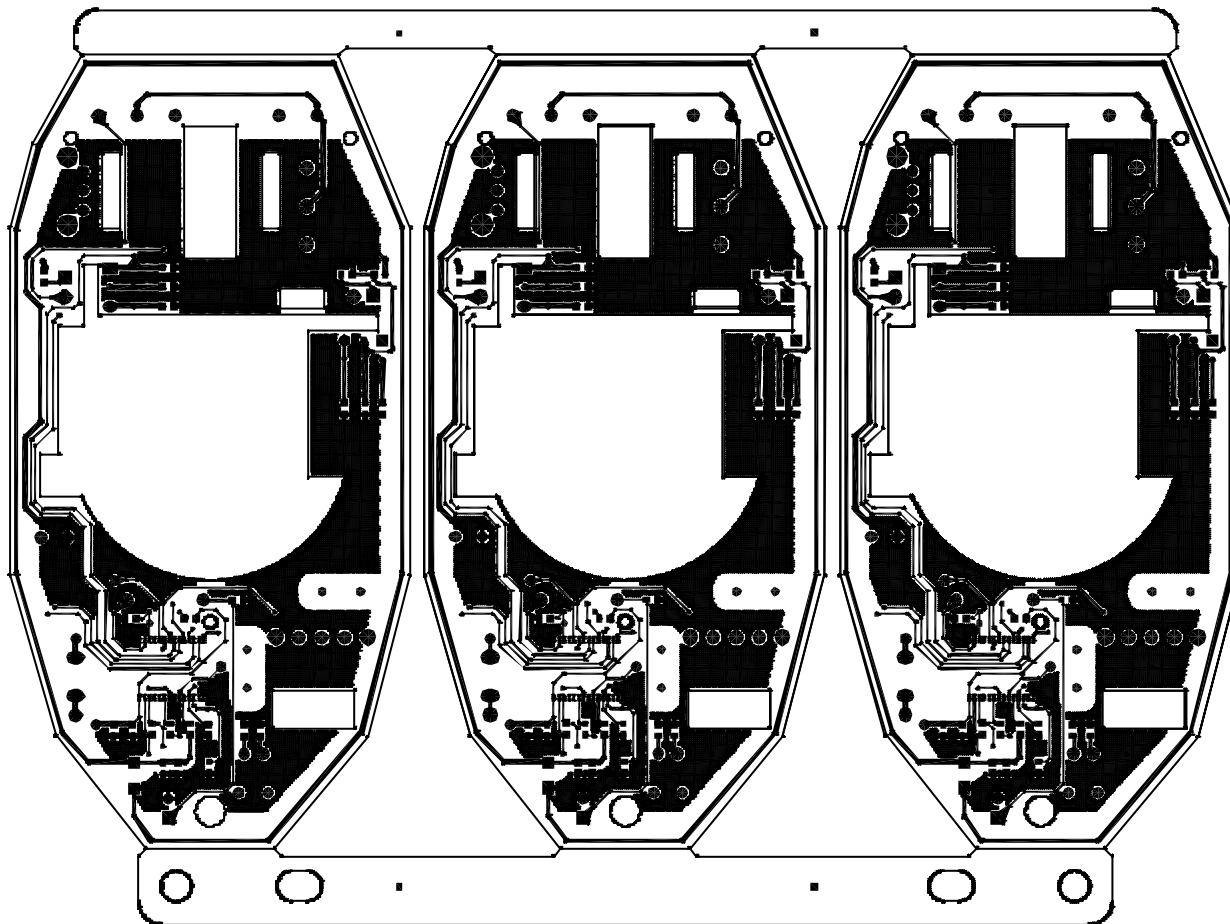

註 1. 本圖是由正面所看到的情形  
 2. 銅箔為鍍金

ITEM	DESCRIPTION	SKIN.	DATE	PROJECTION: 3RD ANGLE	DRAW I-HSIUNG 030426	CHECK	PWB PATTERN A SIDE
1					DESIGN	APRVL	
2				FINISH	QTY. 1 / SET	MATL	PART NAME M3106-PCB
3				CLIENT CODE MUS-01	UNIT M.M.	SCALE 1:1	PART NO. 701-1013

PLEASE DON'T SCALE THE DRAWING DIRECTLY

\*\*

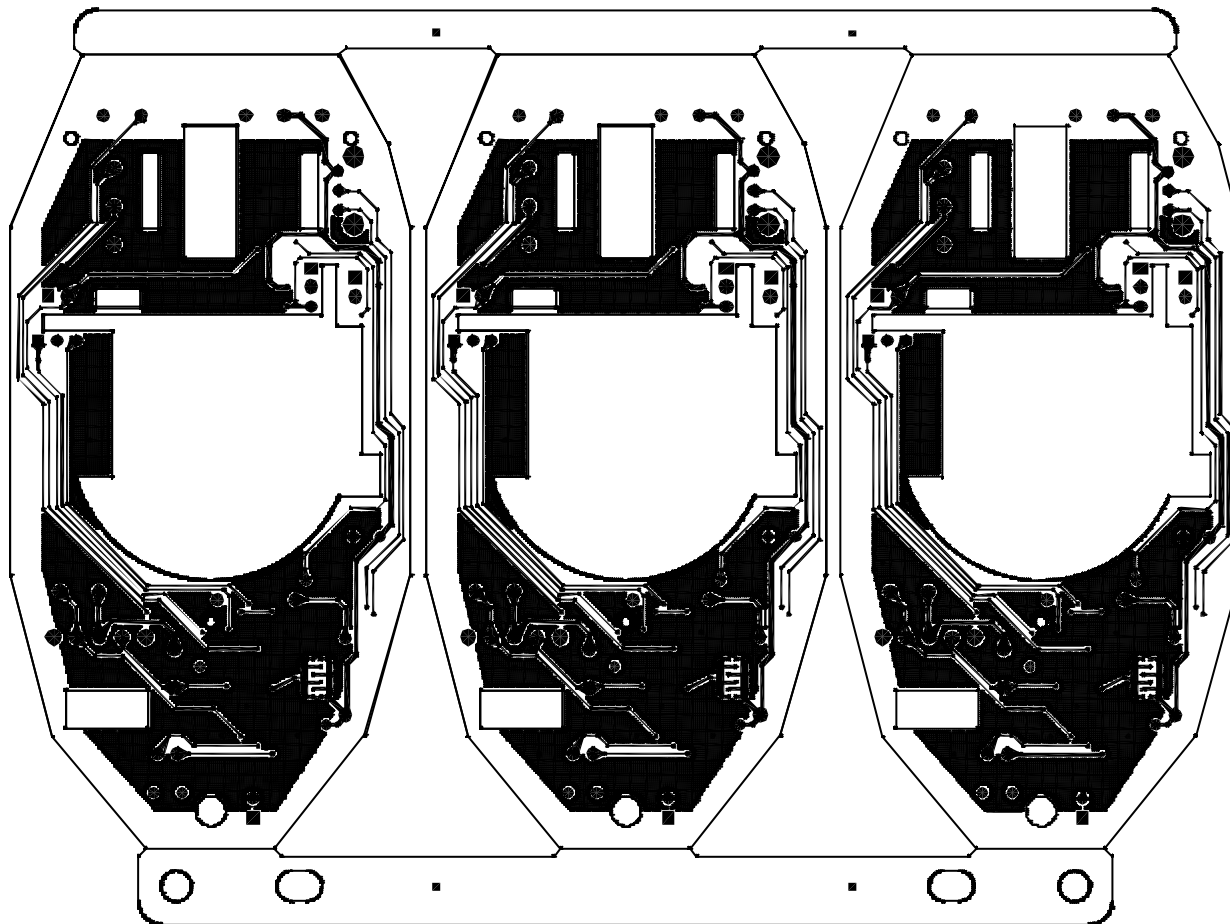

註 1. 本圖是由背面所看到的情形

2. 銅箔為鍍金

ITEM	DESCRIPTION	SKIN.	DATE	PROJECTION: 3RD ANGLE	DRAW I-HSIUNG 030426	CHECK	PWB PATTERN B SIDE
1					DESIGN	APRVL	
2				FINISH	COLOR	QTY. 1 / SET	PART NAME M3106-PCB
3				CLIENT CODE MUS-01	UNIT M.M.	SCALE 1:1	PART NO. 701-1013

PLEASE DON'T SCALE THE DRAWING DIRECTLY

\*\*

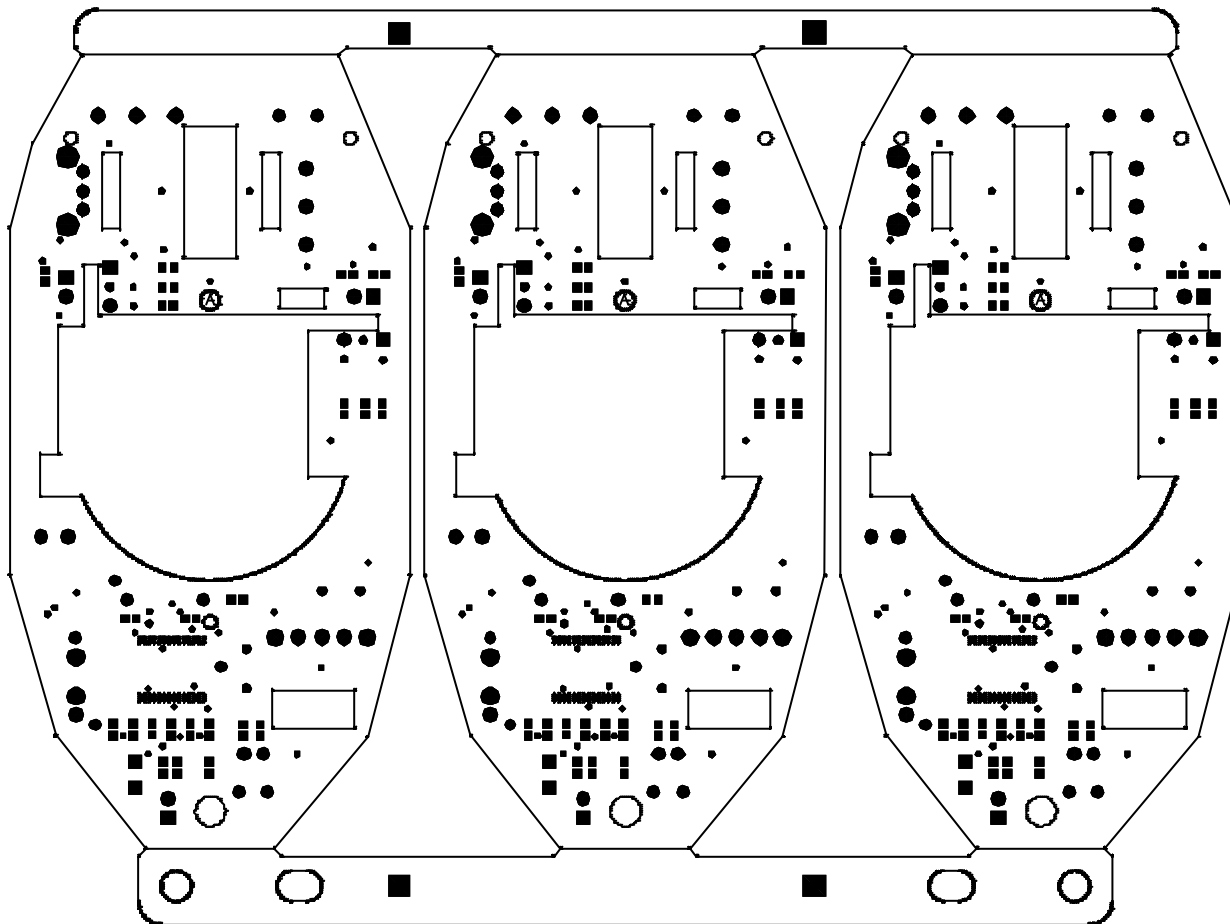

- 註1. 在PWB( 903-2016 )的A面須做防焊層處理
2. 防焊層的誤差以線路為基準在  $\pm 0.1\text{mm}$  以下
3. 本圖塗黑區域以外須做防焊層處理(為綠漆)

ITEM	DESCRIPTION	SIGN.	DATE	PROJECTION: 3RD ANGLE	DRAW I-HSIUNG 030426	CHECK	
1					DESIGN	APRVL	PWB SOLDER SCREEN A SIDE
2				FINISH	COLOR	QTY. 1 / SET	PART NAME M3106-PCB
3				CLIENT CODE MUS-01	UNIT M.M.	SCALE 1:1	PART NO. 701-1013

PLEASE DON'T SCALE THE DRAWING DIRECTLY

\*\*

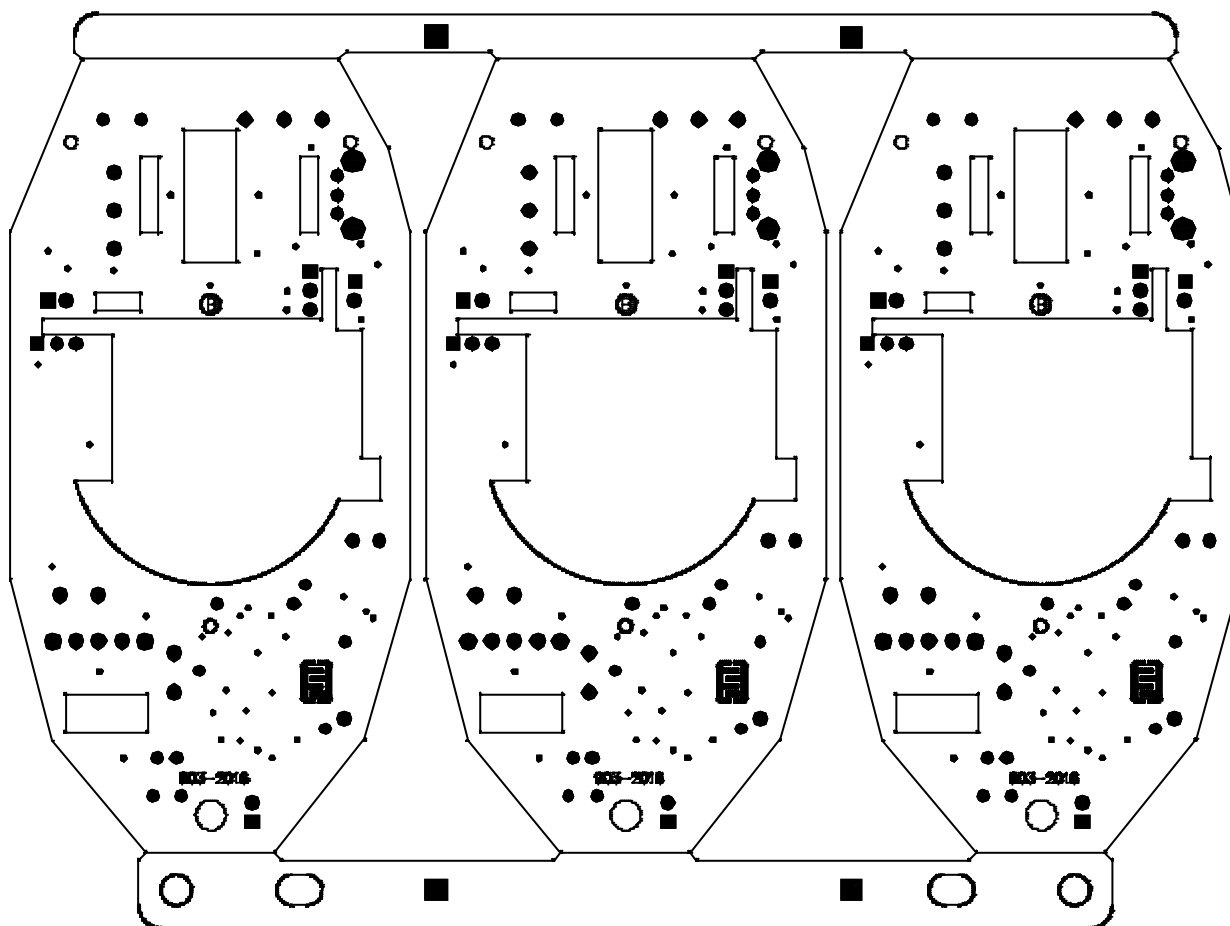

- 註1. 在PWB( 903-2016 )的B面須做防焊層處理.  
 2. 防焊層的誤差以線路為基準在  $\pm 0.1\text{mm}$  以下.  
 3. 本圖塗黑區域以外須做防焊層處理(為綠漆)

ITEM	DESCRIPTION	SIGN	DATE	PROJECTION: 3RD ANGLE	DRAW I-HSIUNG 030426	CHECK	
1					DESIGN	APRVL	PWB SOLDER SCREEN B SIDE
2				FINISH	COLOR	QTY. 1 / SET	MATL. PART NAME M3106-PCB
3				CLIENT CODE MUS-01	UNIT M.M.	SCALE 1:1	PART NO. 701-1013

PLEASE DON'T SCALE THE DRAWING DIRECTLY

\*\*