



FCC PART 90 & RSS-119 TEST REPORT

FCC Part 90 and RSS-119

Report Reference No.....: **WE10100015**
 FCC ID.....: **Q5EPT810003**
 IC.....: **8922A-PT810003**
 Compiled by
 (position+printed name+signature)..: File administrators Eric Zhang 
 Supervised by
 (position+printed name+signature)..: Test Engineer Wenliang Li 
 Approved by
 (position+printed name+signature)..: Manager Jimmy Li 
 Date of issue.....: Nov 29, 2010
Testing Laboratory Name: **Shenzhen Huatongwei International Inspection Co., Ltd**
 Address: Keji Nan No.12 Road, Hi-tech Park, Shenzhen, China

Applicant's name.....: **KIRISUN ELECTRONICS(SHENZHEN) CO., LTD.**
 Address: 6/F., BLDG. H-2, EAST INDUSTRIAL ZONE OF OVERSEAS CHINESE TOWN NANSHAN DIST. SHENZHEN P.R. CHINA

Test specification:
 Standard.....: **FCC Part 90: PRIVATE LAND MOBILE RADIO SERVICES**
RSS-119 Issue 10: Land Mobile and Fixed Radio Transmitters and Receivers Operating in the Frequency Range 27.41-960 MHz
 TRF Originator.....: Shenzhen Huatongwei International Inspection CO., Ltd
 Master TRF.....: Dated 2006-06

Shenzhen Huatongwei International Inspection Co., Ltd. All rights reserved.
 This publication may be reproduced in whole or in part for non-commercial purposes as long as the Shenzhen Huatongwei International Inspection Co., Ltd is acknowledged as copyright owner and source of the material. Shenzhen Huatongwei International Inspection Co., Ltd takes no responsibility for and will not assume liability for damages resulting from the reader's interpretation of the reproduced material due to its placement and context.

Test item description: Mobile Radio
 Trade Mark: 
 Model/Type reference.....: PT8100-03
 Listed Models: /
 Ratings: DC 13.60 V
 Rated Output Power.....: 25 Watt(43.98 dBm)/5Watt(36.99 dBm)
 Modulation/Channel Separation: FM/12.5KHz&25KHz
 Frequency Range.....: From 450 MHz to 470 MHz for IC
 From 438 MHz to 490 MHz for FCC
 Result.....: **Positive**

TEST REPORT

Test Report No. :	WE10100015	Nov 29, 2010
		Date of issue

Equipment under Test : Mobile Radio

Model /Type : PT8100-03

Listed Models : /

Applicant : **KIRISUN ELECTRONICS(SHENZHEN) CO., LTD.**

Address : 6/F., BLDG. H-2, EAST INDUSTRIAL ZONE OF
OVERSEAS CHINESE TOWN NANSHAN DIST.
SHENZHEN P.R. CHINA

Manufacturer : **KIRISUN ELECTRONICS(SHENZHEN) CO., LTD.**

Address : 6/F., BLDG. H-2, EAST INDUSTRIAL ZONE OF
OVERSEAS CHINESE TOWN NANSHAN DIST.
SHENZHEN P.R. CHINA

Test Result according to the standards on page 4:	Positive
--	-----------------

The test report merely corresponds to the test sample.
It is not permitted to copy extracts of these test result without the written permission of the test laboratory.

Contents

1.	<u>TEST STANDARDS</u>	4
2.	<u>SUMMARY</u>	5
2.1.	General Remarks	5
2.2.	Product Description	5
2.3.	Equipment under Test	5
2.4.	Short description of the Equipment under Test (EUT)	6
2.5.	EUT Configuration	6
2.6.	EUT operation mode	6
2.7.	EUT configuration	6
2.8.	Related Submittal(s) / Grant (s)	6
2.9.	Modifications	6
2.10.	Note	6
3.	<u>TEST ENVIRONMENT</u>	7
3.1.	Address of the test laboratory	7
3.2.	Test Facility	7
3.3.	Environmental conditions	8
3.4.	Configuration of Tested System	8
3.5.	Description of Tested Modes	8
3.6.	Statement of the measurement uncertainty	8
3.7.	Test Description	9
3.8.	Equipments Used during the Test	9
4.	<u>TEST CONDITIONS AND RESULTS</u>	11
4.1.	Conducted Emissions	11
4.2.	Occupied Bandwidth & Emission Mask	20
4.3.	Transmitter Radiated Spurious Emission	41
4.4.	Spurious Emission on Antenna Port	48
4.5.	Modulation Characteristics	87
4.6.	Frequency Stability	95
4.7.	Maximum Transmitter Power	98
4.8.	Transmitter Frequency Behavior	112
4.9.	Receiver Radiated Spurious Emission	117
4.10.	Receiver Conducted Spurious Emission	127
4.11.	RF Exposure Evaluation	140
5.	<u>TEST SETUP PHOTOS OF THE EUT</u>	143
6.	<u>EXTERNAL AND INTERNAL PHOTOS OF THE EUT</u>	146

1. TEST STANDARDS

The tests were performed according to following standards:

FCC Rules Part 90: PRIVATE LAND MOBILE RADIO SERVICES.

RSS-119 Issue 10 April 2010: Spectrum Management and Telecommunications Radio Standards Specification Land Mobile and Fixed Radio Transmitters and Receivers Operating in the Frequency Range 27.41-960 MHz.

TIA/EIA 603: Land Mobile FM or PM Communications Equipment Measurement and Performance Standards.

ANSI C63.4-2009: American National Standard for Methods of Measurement of Radio-Noise Emissions from Low-Voltage Electrical and Electronic Equipment in the Range of 9 kHz to 40 GHz.

2. SUMMARY

2.1. General Remarks

Date of receipt of test sample	:	Oct 25, 2010
Testing commenced on	:	Oct 25, 2010
Testing concluded on	:	Nov 29, 2010

2.2. Product Description

The KIRISUN ELECTRONICS (SHENZHEN) CO., LTD.'s Model: PT8100-03 or the "EUT" as referred to in this report; more general information as follows:

Name of EUT	Mobile Radio	
Model Number	PT8100-03	
FCC ID:	Q5EPT810003	
IC	8922A-PT810003	
Rated Output Power	25W(43.98 dBm)/5Watt(36.99dBm)	
Modulation Type	FM for Analog Voice	
Emission Designator	Analog	16K0F3E for 25KHz Channel Separation
		11K50F3E for 12.5KHz Channel Separation
Channel Separation	Analog Voice	12.5KHz&25KHz
Antenna Type	External	
Frequency Range	From 450 MHz to 470 MHz for IC From 438 MHz to 490 MHz for FCC	
Maximum Transmitter Power	Analog/FCC	<u>22.39 W</u> for 25 KHz Channel Separation f <u>22.49 W</u> for 12.5 KHz Channel Separation
	Analog/IC	<u>22.44 W</u> for 25 KHz Channel Separation f <u>22.54 W</u> for 12.5 KHz Channel Separation

2.3. Equipment under Test

Power supply system utilised

Power supply voltage	:	<input type="radio"/> 120V / 60 Hz	<input type="radio"/> 115V / 60Hz
		<input type="radio"/> 12 V DC	<input type="radio"/> 24 V DC
		<input checked="" type="radio"/> Other (specified in blank below)	

DC 13.60V

Test frequency list

Modulation Type	Certification Type	Test Channel	Test Frequency
Analog/FM	FCC	Low Channel	438.1250 MHz
		Middle Channel	464.1250 MHz
		High Channel	489.9875 MHz
	IC	Low Channel	450.1250 MHz
		Middle Channel	460.1250 MHz
		High Channel	469.9875 MHz

2.4. Short description of the Equipment under Test (EUT)

438-490MHz V frequency band Mobile Radio (PT8100-03).

For more details, refer to the user's manual of the EUT.

Serial number: Prototype

2.5. EUT Configuration

The EUT configuration for testing is installed on RF field strength measurement to meet the Commission's requirement and operating in a manner which intends to maximize its emission characteristics in a continuous normal application.

2.6. EUT operation mode

The EUT has been tested under typical operating condition and The Transmitter was operated in the normal operating mode. The TX frequency was fixed which was for the purpose of the measurements.

2.7. EUT configuration

The following peripheral devices and interface cables were connected during the measurement:

● - supplied by the manufacturer

○ - supplied by the lab

<input type="radio"/>	Power Cable	Length (m) :	3
		Shield :	Unshield
		Detachable :	Undetachable
<input type="radio"/>	Multimeter	Manufacturer :	/
		Model No. :	/

2.8. Related Submittal(s) / Grant (s)

This submittal(s) (test report) is intended for FCC ID: **Q5EPT810003** and IC: **8922A-PT810003** filing to comply with FCC Part 90 Rules and RSS-119.

2.9. Modifications

No modifications were implemented to meet testing criteria.

2.10. Note

- The EUT is a 438-490 MHz frequency band Mobile Radio (PT8100-03), The functions of the EUT listed as below:

	Test Standards	Reference Report
Radio	FCC Part 90	WE10100015
Radio	RSS-119	WE10100015
Health	Oet 65	WE10100016

3. TEST ENVIRONMENT

3.1. Address of the test laboratory

Shenzhen Huatongwei International Inspection Co., Ltd
Keji Nan No.12 Road, Hi-tech Park, Shenzhen, China
Phone: 86-755-26715686 Fax: 86-755-26748089

The sites are constructed in conformance with the requirements of ANSI C63.7, ANSI C63.4 (2009) and CISPR Publication 22.

3.2. Test Facility

The test facility is recognized, certified, or accredited by the following organizations:

CNAS-Lab Code: L1225

Shenzhen Huatongwei International Inspection Co., Ltd has been assessed and proved to be in compliance with CNAS-CL01 Accreditation Criteria for Testing and Calibration Laboratories (identical to ISO/IEC 17025: 2005 General Requirements) for the Competence of Testing and Calibration Laboratories, Date of Registration: August 02, 2007. Valid time is until March 29, 2012.

A2LA-Lab Cert. No. 2243.01

Shenzhen Huatongwei International Inspection Co., Ltd, EMC Laboratory has been accredited by A2LA for technical competence in the field of electrical testing, and proved to be in compliance with ISO/IEC 17025: 2005 General Requirements for the Competence of Testing and Calibration Laboratories and any additional program requirements in the identified field of testing. Valid time to Sep 30, 2011.

FCC-Registration No.: 662850

Shenzhen Huatongwei International Inspection Co., Ltd, EMC Laboratory has been registered and fully described in a report filed with the FCC (Federal Communications Commission). The acceptance letter from the FCC is maintained in our files. Registration 662850, Renewal date July 01, 2009.

IC-Registration No.: 5377

The 3m Alternate Test Site of Shenzhen Huatongwei International Inspection Co., Ltd has been registered by Certification and Engineering Bureau of Industry Canada for the performance of radiated measurements with Registration No. 5377 on February 13th, 2009.

ACA

Shenzhen Huatongwei International Inspection Co., Ltd, EMC Laboratory can also perform testing for the Australian C-Tick mark as a result of our A2LA accreditation.

NEMKO-Aut. No.: ELA125

Shenzhen Huatongwei International Inspection Co., Ltd has been assessed the quality assurance system, the testing facilities, qualifications and testing practices of the relevant parts of the organization. The quality assurance system of the Laboratory has been validated against ISO/IEC 17025:2005 or equivalent. The laboratory also fulfils the conditions described in Nemko Document NLA-10; the Authorization is valid through July 07, 2011.

VCCI

The 3m Semi-anechoic chamber (12.2m×7.95m×6.7m) and Shielded Room (8m×4m×3m) of Shenzhen Huatongwei International Inspection Co., Ltd has been registered in accordance with the Regulations for Voluntary Control Measures with Registration No.: R-2484. December 20, 2009. Valid time is until December 19, 2012.

Main Ports Conducted Interference Measurement of Shenzhen Huatongwei International Inspection Co., Ltd has been registered in accordance with the Regulations for Voluntary Control Measures with Registration No.: C-2726. Date of Registration: December 20, 2009. Valid time is until December 19, 2012.

DNV

Shenzhen Huatongwei International Inspection Co Ltd has been found to comply with the requirements of DNV towards subcontractor of EMC and safety testing services in conjunction with the EMC and Low voltage Directives and in the voluntary field. The acceptance is based on a formal quality Audit and follow-ups according to relevant parts of ISO/IEC Guide 17025(2005), in accordance with the requirements of the DNV Laboratory Quality Manual towards subcontractors. Valid time is until 24 August, 2013.

3.3. Environmental conditions

During the measurement the environmental conditions were within the listed ranges:

Temperature:	15-35 ° C
Humidity:	30-60 %
Atmospheric pressure:	950-1050mbar

3.4. Configuration of Tested System

Fig. 2-1 Configuration of Tested System

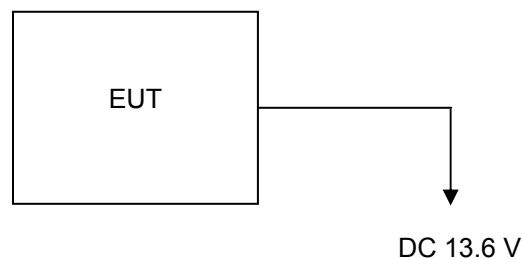

3.5. Discription of Tested Modes

The EUT (Mobile Radio) has been tested under normal operating condition. Three channels (the high, the middle and the low) are chosen for testing at each channel separation (12.5 KHz/ 25KHz).

3.6. Statement of the measurement uncertainty

The data and results referenced in this document are true and accurate. The reader is cautioned that there may be errors within the calibration limits of the equipment and facilities. The measurement uncertainty was calculated for all measurements listed in this test report acc. to CISPR 16 - 4 „Specification for radio disturbance and immunity measuring apparatus and methods – Part 4: Uncertainty in EMC Measurements“ and is documented in the Shenzhen Huatongwei International Inspection Co., Ltd quality system acc. to DIN EN ISO/IEC 17025. Furthermore, component and process variability of devices similar to that tested may result in additional deviation. The manufacturer has the sole responsibility of continued compliance of the device.

Hereafter the best measurement capability for Shenzhen Huatongwei laboratory is reported:

Test Items	Measurement Uncertainty	Notes
Frequency stability	± 150 Hz	(1)
Transmitter power conducted	± 0.30 dB	(1)
Transmitter power Radiated	± 2.20 dB	(1)
Conducted spurious emission 9KHz-12.75 GHz	± 1.60 dB	(1)
Radiated spurious emission 9KHz-12.75 GHz	± 2.20 dB	(1)
Conducted Emission 9KHz-30MHz	± 3.39 dB	(1)
Radiated Emission 30~1000MHz	± 4.24 dB	(1)
Radiated Emissio 1~18GHz	± 5.16 dB	(1)
Radiated Emissio 18-40GHz	± 5.54 dB	(1)
Occupied Bandwidth	-----	(1)
Emission Mask	-----	(1)
Modulation Characteristic	-----	(1)
Transmitter Frequency Behavior	-----	(1)

(1) This uncertainty represents an expanded uncertainty expressed at approximately the 95% confidence level using a coverage factor of k=2.

3.7. Test Description

FCC Rules	RSS-119	Description of Test	Test Result
§ 15.107	RSS-Gen	Conducted Emission	Complies
§ 15.109	RSS-Gen	Receiver Radiated Spurious Emssion	Complies
§ 15.109	RSS-Gen	Receiver Conducted Spurious Emssion	Complies
§ 90.205	§ 5.4	Maximum Transmitter Power	Complies
§ 90.207	§ 5.13	Modulation Characteristic	Complies
§ 90.209	§ 5.5	Occupied Bandwidth	Complies
§ 90.210	§ 5.8	Emission Mask	Complies
§ 90.213	§ 5.3	Frequency Stability	Complies
§ 90.214	§ 5.9	Transmitter Frequency Behavior	Complies
§ 90.210	§ 5.8	Transmitter Radiated Spurious Emssion	Complies
§ 90.210	§ 5.8	Spurious Emssion On Antenna Port	Complies
§ 2.1091	RSS-102	RF Exposure Evaluation	Complies

3.8. Equipments Used during the Test

DC Power Conducted Emission				
Name of Equipment	Manufacturer	Model	Serial Number	Calibration Due
Artificial Mains	Rohde&Schwarz	ESH2-Z5	100028	11/2011
EMI Test Receiver	Rohde&Schwarz	ESCS 30	100038	11/2011
Pulse Limiter	Rohde&Schwarz	ESHSZ2	100044	11/2011
EMI Test Software	Rohde&Schwarz	ES-K1 V1.71	N/A	11/2011

Transmitter Radiated Spurious Emssion & Occupied Bandwidth & Emission Mask & Receiver Radiated Spurious Emssion				
Name of Equipment	Manufacturer	Model	Serial Number	Calibration Due
Ultra-Broadband Antenna	Rohde&Schwarz	HL562	100015	11/2011
EMI Test Receiver	Rohde&Schwarz	ESI 26	100009	11/2011
RF Test Panel	Rohde&Schwarz	TS / RSP	335015/ 0017	N/A
Turntable	ETS	2088	2149	N/A
Antenna Mast	ETS	2075	2346	N/A
EMI Test Software	Rohde&Schwarz	ES-K1 V1.71	N/A	11/2011
RF COMMUNICATION TEST SET	HP	8920A	3813A10206	11/2011

Modulation Characteristic				
Name of Equipment	Manufacturer	Model	Serial Number	Calibration Due
Modulation Analyzer	HP	8901B	3104A03367	11/2011
Signal Generator	Rohde&Schwarz	SMT03	100059	11/2011
RF COMMUNICATION TEST SET	HP	8920A	3813A10206	11/2011

Frequency Stability				
Name of Equipment	Manufacturer	Model	Serial Number	Calibration Due
Communication Test Set	HP	HP8920B	US35010135	11/2011
Signal Generator	Rohde&Schwarz	SMT03	100059	11/2011
Climate Chamber	ESPEC	EL-10KA	05107008	11/2011

Maximum Transmitter Power & Spurious Emssion On Antenna Port				
Name of Equipment	Manufacturer	Model	Serial Number	Calibration Due
Receiver	Rohde&Schwarz	ESI 26	100009	11/2011
Attenuator	R&S	ESH3-22	100449	11/2011
RF COMMUNICATION TEST SET	HP	8920A	3813A10206	11/2011
High-Pass Filter	Anritsu	MP526B	6220875256	11/2011
High-Pass Filter	Anritsu	MP526D	6220878392	11/2011

Transient Frequency Behavior				
Name of Equipment	Manufacturer	Model	Serial Number	Calibration Due
Signal Generator	Rohde&Schwarz	SMT03	100059	11/2011
Storage Oscilloscope	Tektronix	TDS3054B	B033027	11/2011
RF COMMUNICATION TEST SET	HP	8920A	3813A10206	11/2011

4. TEST CONDITIONS AND RESULTS

4.1. Conducted Emissions

TEST APPLICABLE

The EUT was tested according to ANSI C63.4 - 2009. The frequency spectrum from 0.15 MHz to 30 MHz was investigated. The LISN used was 50 ohm / 50 u Henry as specified by section 5.1 of ANSI C63.4 - 2009. Cables and peripherals were moved to find the maximum emission levels for each frequency.

TEST CONFIGURATION

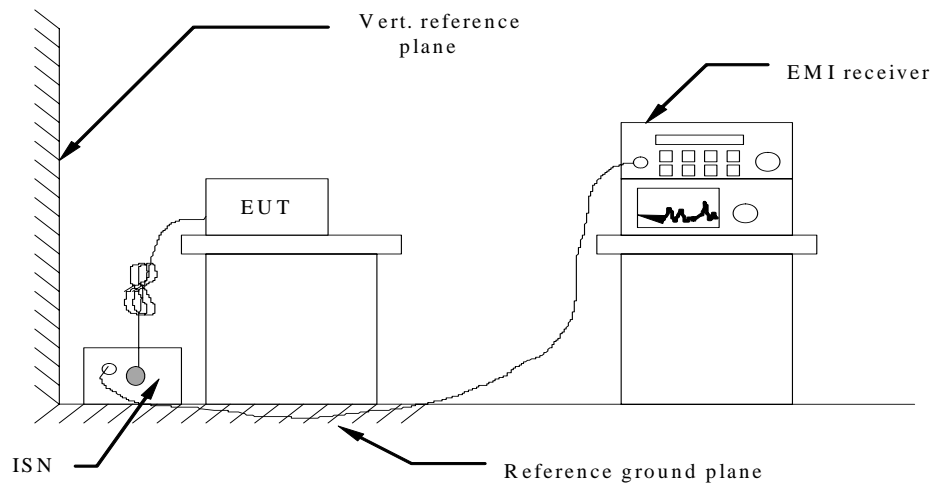

TEST PROCEDURE

- 1 The equipment was set up as per the test configuration to simulate typical actual usage per the user's manual. The EUT is a tabletop system; a wooden table with a height of 0.8 meters is used and is placed on the ground plane as per ANSI C63.4-2009.
- 2 Support equipment, if needed, was placed as per ANSI C63.4-2009.
- 3 All I/O cables were positioned to simulate typical actual usage as per ANSI C63.4-2009.
- 4 If a EUT received DC power from the adapter, the adapter received AC120V/60Hz power through a Line Impedance Stabilization Network (LISN) which supplied power source and was grounded to the ground plane.
- 5 All support equipments received AC power from a second LISN, if any.
- 6 The EUT test program was started. Emissions were measured on each current carrying line of the EUT using a spectrum Analyzer / Receiver connected to the LISN powering the EUT. The LISN has two monitoring points: Line 1 (Hot Side) and Line 2 (Neutral Side). Two scans were taken: one with Line 1 connected to Analyzer / Receiver and Line 2 connected to a 50 ohm load; the second scan had Line 1 connected to a 50 ohm load and Line 2 connected to the Analyzer / Receiver.
- 7 Analyzer / Receiver scanned from 150 KHz to 30MHz for emissions in each of the test modes.
- 8 During the above scans, the emissions were maximized by cable manipulation.

Conducted Power Line Emission Limit

For unintentional device, according to § 15.107(a) Line Conducted Emission Limits is as following :

Frequency (MHz)	Maximum RF Line Voltage (dBµV)			
	CLASS A		CLASS B	
	Q.P.	Ave.	Q.P.	Ave.
0.15 - 0.50	79	66	66-56*	56-46*
0.50 - 5.00	73	60	56	46
5.00 - 30.0	73	60	60	50

* Decreasing linearly with the logarithm of the frequency

For intentional device, according to §15.207(a) Line Conducted Emission Limit is same as above table.

TEST RESULTS

For FCC

For FM Modulation @ 25 KHz TX Mode

SCAN TABLE: "Voltage (9K-30M) FIN"

Short Description: 150K-30M Voltage

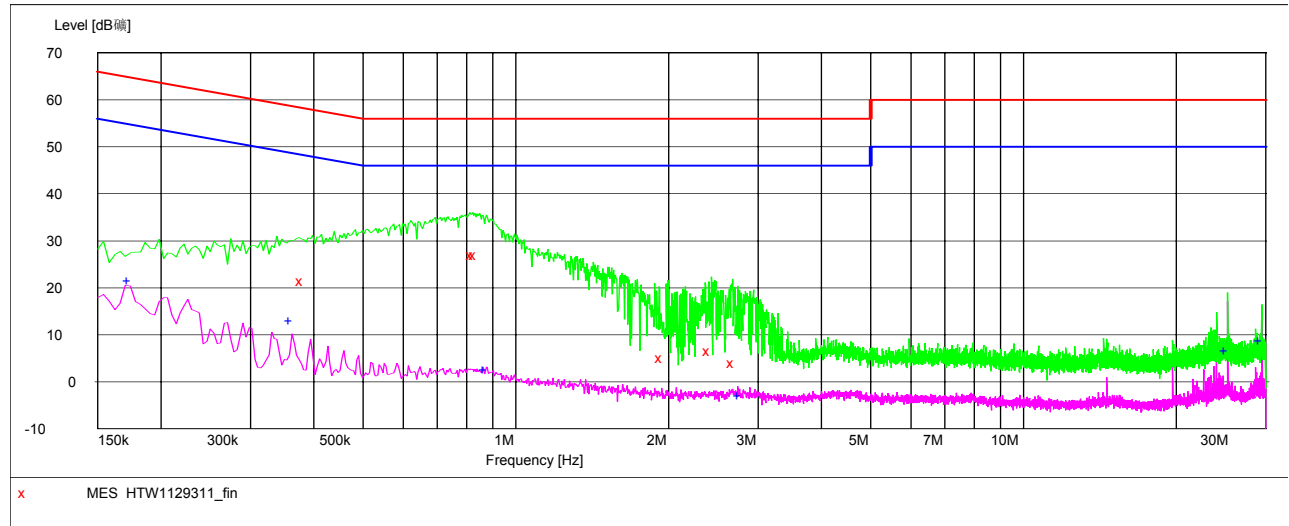

MEASUREMENT RESULT: "HTW1129311_fin"

11/29/2010 3:28PM

Frequency MHz	Level dBμV	Transd dB	Limit dBμV	Margin dB	Detector	Line	PE
0.382000	21.30	10.2	58	36.9	QP	-	GND
0.826000	26.90	10.2	56	29.1	QP	-	GND
0.838000	26.90	10.2	56	29.1	QP	-	GND
1.950000	5.00	10.5	56	51.0	QP	-	GND
2.414000	6.40	10.5	56	49.6	QP	-	GND
2.694000	4.00	10.5	56	52.0	QP	-	GND

MEASUREMENT RESULT: "HTW1129311_fin2"

11/29/2010 3:28PM

Frequency MHz	Level dBμV	Transd dB	Limit dBμV	Margin dB	Detector	Line	PE
0.174000	21.30	10.3	55	33.5	AV	-	GND
0.362000	13.00	10.2	49	35.7	AV	-	GND
0.874000	2.40	10.3	46	43.6	AV	-	GND
2.774000	-3.00	10.5	46	49.0	AV	-	GND
25.202000	6.50	11.2	50	43.5	AV	-	GND
29.498000	8.60	11.3	50	41.4	AV	-	GND

SCAN TABLE: "Voltage (9K-30M)FIN"

Short Description: 150K-30M Voltage

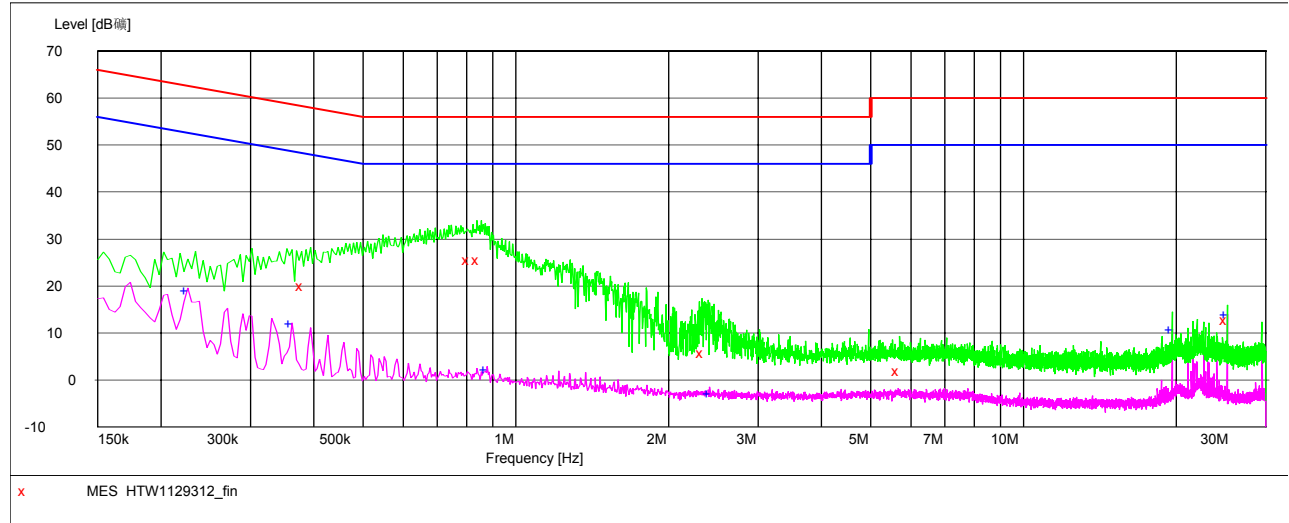

MEASUREMENT RESULT: "HTW1129312_fin"

11/29/2010 3:31PM

Frequency MHz	Level dBμV	Transd dB	Limit dBμV	Margin dB	Detector	Line	PE
0.382000	19.90	10.2	58	38.3	QP	+	GND
0.810000	25.60	10.2	56	30.4	QP	+	GND
0.846000	25.60	10.2	56	30.4	QP	+	GND
2.342000	5.60	10.5	56	50.4	QP	+	GND
5.690000	1.90	10.6	60	58.1	QP	+	GND
25.202000	12.70	11.2	60	47.3	QP	+	GND

MEASUREMENT RESULT: "HTW1129312_fin2"

11/29/2010 3:31PM

Frequency MHz	Level dBμV	Transd dB	Limit dBμV	Margin dB	Detector	Line	PE
0.226000	18.90	10.3	53	33.7	AV	+	GND
0.362000	11.90	10.2	49	36.8	AV	+	GND
0.878000	2.00	10.3	46	44.0	AV	+	GND
2.414000	-3.10	10.5	46	49.1	AV	+	GND
19.666000	10.50	10.9	50	39.5	AV	+	GND
25.202000	13.80	11.2	50	36.2	AV	+	GND

For FM Modulation @ 12.5 KHz TX Mode

SCAN TABLE: "Voltage (9K-30M) FIN"

Short Description: 150K-30M Voltage

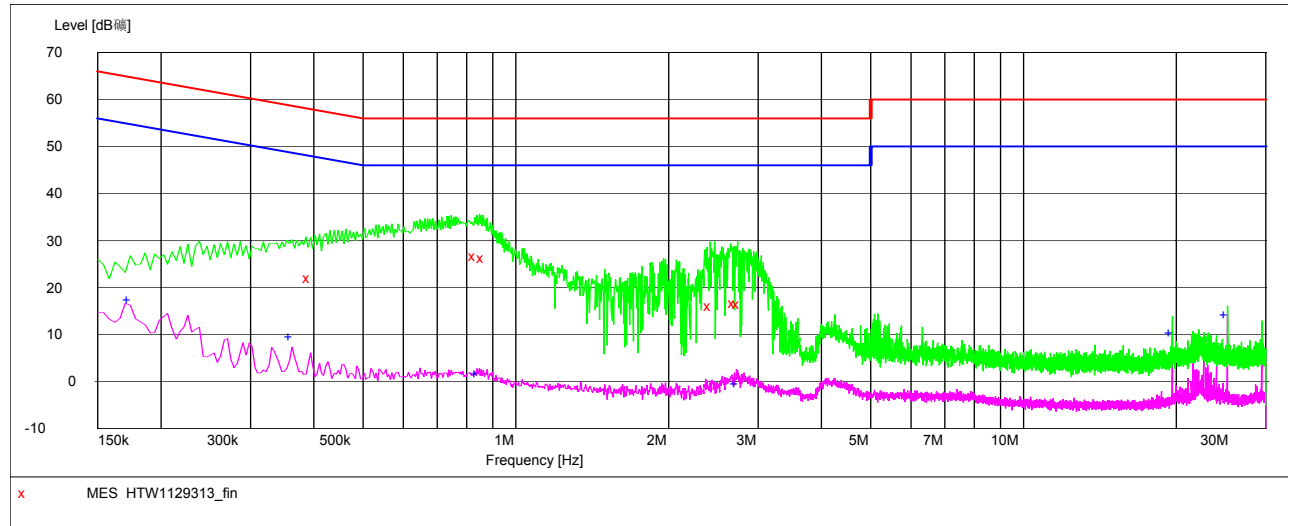

MEASUREMENT RESULT: "HTW1129313_fin"

11/29/2010 3:35PM

Frequency MHz	Level dBμV	Transd dB	Limit dBμV	Margin dB	Detector	Line	PE
0.394000	21.90	10.2	58	36.1	QP	+	GND
0.834000	26.70	10.2	56	29.3	QP	+	GND
0.866000	26.30	10.2	56	29.7	QP	+	GND
2.430000	16.00	10.5	56	40.0	QP	+	GND
2.714000	16.60	10.5	56	39.4	QP	+	GND
2.762000	16.40	10.5	56	39.6	QP	+	GND

MEASUREMENT RESULT: "HTW1129313_fin2"

11/29/2010 3:35PM

Frequency MHz	Level dBμV	Transd dB	Limit dBμV	Margin dB	Detector	Line	PE
0.174000	17.30	10.3	55	37.5	AV	+	GND
0.362000	9.40	10.2	49	39.3	AV	+	GND
0.842000	1.50	10.2	46	44.5	AV	+	GND
2.738000	-0.60	10.5	46	46.6	AV	+	GND
19.666000	10.20	10.9	50	39.8	AV	+	GND
25.202000	14.10	11.2	50	35.9	AV	+	GND

SCAN TABLE: "Voltage (9K-30M) FIN"

Short Description: 150K-30M Voltage

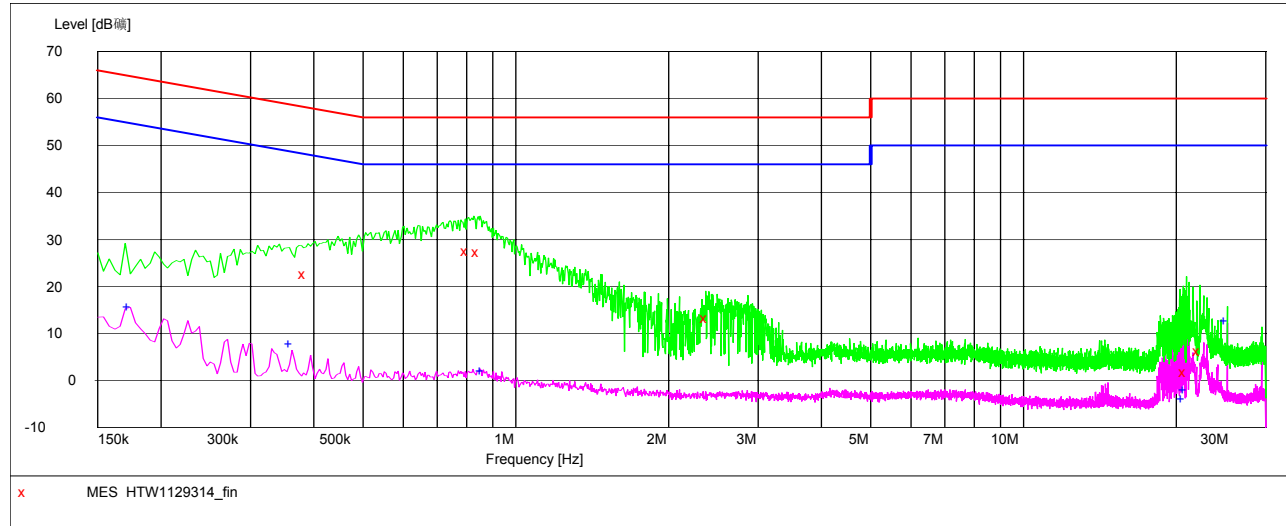

MEASUREMENT RESULT: "HTW1129314_fin"

11/29/2010 3:41PM

Frequency MHz	Level dBμV	Transd dB	Limit dBμV	Margin dB	Detector	Line	PE
0.386000	22.60	10.2	58	35.5	QP	-	GND
0.806000	27.60	10.2	56	28.4	QP	-	GND
0.846000	27.40	10.2	56	28.6	QP	-	GND
2.386000	13.20	10.5	56	42.8	QP	-	GND
20.910000	1.80	11.0	60	58.2	QP	-	GND
22.310000	6.30	11.1	60	53.7	QP	-	GND

MEASUREMENT RESULT: "HTW1129314_fin2"

11/29/2010 3:41PM

Frequency MHz	Level dBμV	Transd dB	Limit dBμV	Margin dB	Detector	Line	PE
0.174000	15.70	10.3	55	39.1	AV	-	GND
0.362000	7.70	10.2	49	41.0	AV	-	GND
0.862000	2.00	10.2	46	44.0	AV	-	GND
20.730000	-4.00	11.0	50	54.0	AV	-	GND
20.962000	-2.10	11.0	50	52.1	AV	-	GND
25.202000	12.50	11.2	50	37.5	AV	-	GND

For IC

For FM Modulation @ 25 KHz TX Mode

SCAN TABLE: "Voltage (9K-30M)FIN"

Short Description: 150K-30M Voltage

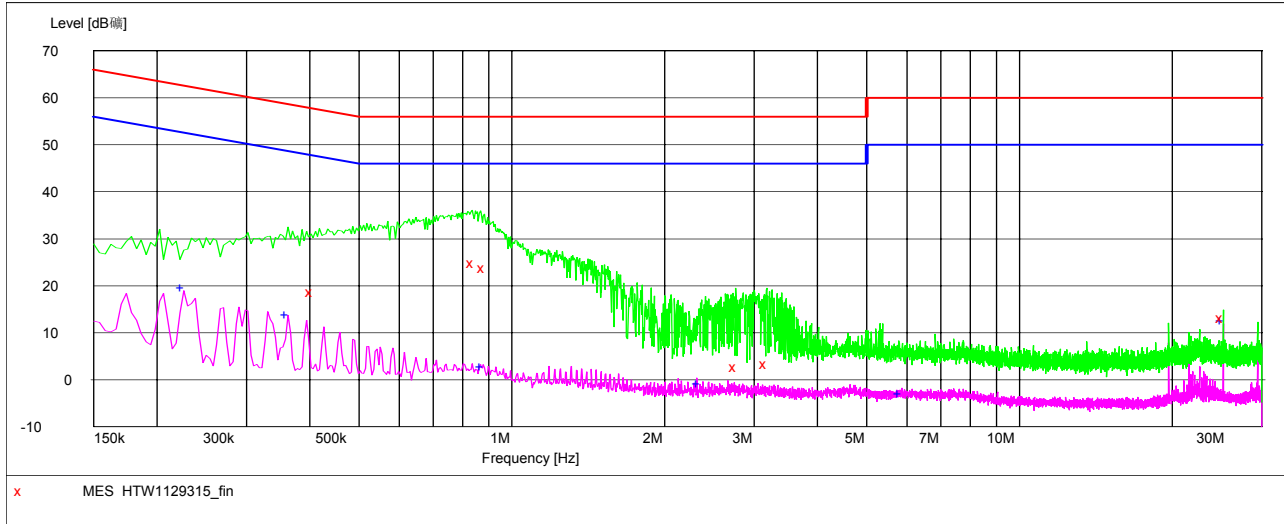

MEASUREMENT RESULT: "HTW1129315_fin"

11/29/2010 3:46PM

Frequency MHz	Level dBμV	Transd dB	Limit dBμV	Margin dB	Detector	Line	PE
0.406000	18.60	10.2	58	39.1	QP	-	GND
0.842000	24.80	10.2	56	31.2	QP	-	GND
0.886000	23.70	10.3	56	32.3	QP	-	GND
2.770000	2.70	10.5	56	53.3	QP	-	GND
3.182000	3.30	10.5	56	52.7	QP	-	GND
25.202000	13.10	11.2	60	46.9	QP	-	GND

MEASUREMENT RESULT: "HTW1129315_fin2"

11/29/2010 3:46PM

Frequency MHz	Level dBμV	Transd dB	Limit dBμV	Margin dB	Detector	Line	PE
0.226000	19.50	10.3	53	33.1	AV	-	GND
0.362000	13.80	10.2	49	34.9	AV	-	GND
0.878000	2.60	10.3	46	43.4	AV	-	GND
2.346000	-1.00	10.5	46	47.0	AV	-	GND
5.842000	-3.00	10.6	50	53.0	AV	-	GND
25.202000	12.40	11.2	50	37.6	AV	-	GND

SCAN TABLE: "Voltage (9K-30M) FIN"

Short Description: 150K-30M Voltage

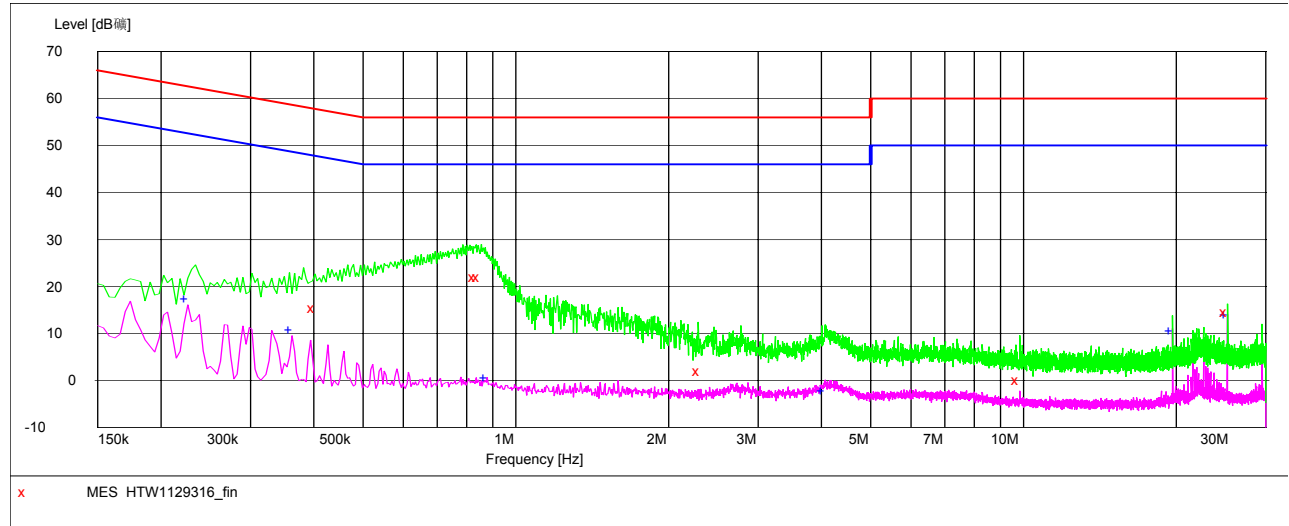

MEASUREMENT RESULT: "HTW1129316_fin"

11/29/2010 3:51PM

Frequency MHz	Level dBμV	Transd dB	Limit dBμV	Margin dB	Detector	Line	PE
0.402000	15.50	10.2	58	42.3	QP	+	GND
0.834000	21.90	10.2	56	34.1	QP	+	GND
0.850000	21.90	10.2	56	34.1	QP	+	GND
2.302000	2.10	10.5	56	53.9	QP	+	GND
9.798000	0.00	10.9	60	60.0	QP	+	GND
25.202000	14.60	11.2	60	45.4	QP	+	GND

MEASUREMENT RESULT: "HTW1129316_fin2"

11/29/2010 3:51PM

Frequency MHz	Level dBμV	Transd dB	Limit dBμV	Margin dB	Detector	Line	PE
0.226000	17.40	10.3	53	35.2	AV	+	GND
0.362000	10.80	10.2	49	37.9	AV	+	GND
0.878000	0.50	10.3	46	45.5	AV	+	GND
4.054000	-2.30	10.6	46	48.3	AV	+	GND
19.666000	10.60	10.9	50	39.4	AV	+	GND
25.202000	13.90	11.2	50	36.1	AV	+	GND

For FM Modulation @ 12.5 KHz TX Mode

SCAN TABLE: "Voltage (9K-30M)FIN"

Short Description: 150K-30M Voltage

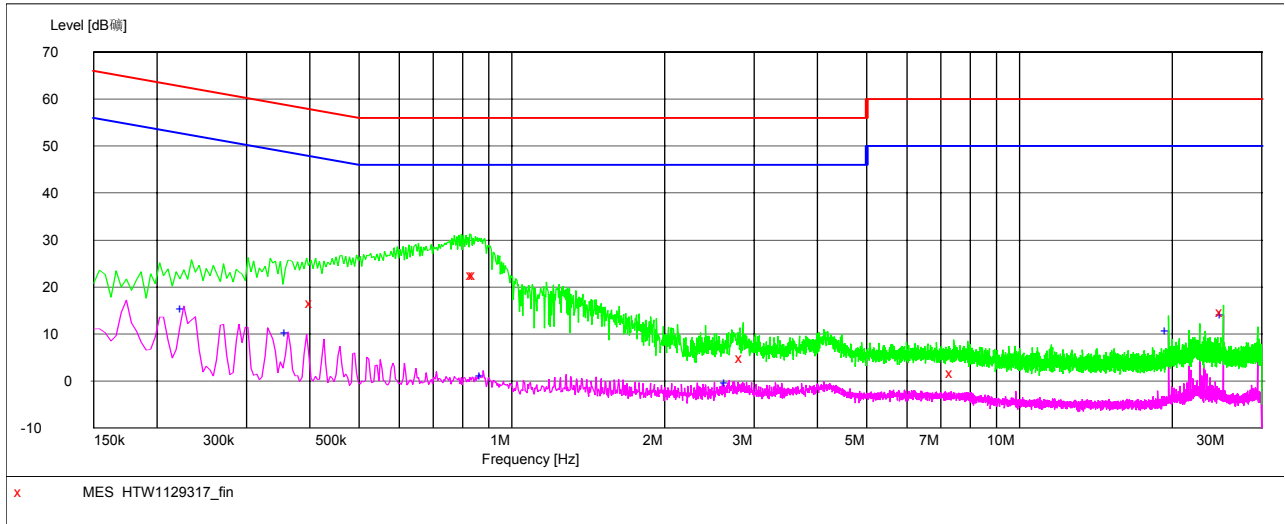

MEASUREMENT RESULT: "HTW1129317_fin"

11/29/2010 3:55PM

Frequency MHz	Level dBμV	Transd dB	Limit dBμV	Margin dB	Detector	Line	PE
0.406000	16.60	10.2	58	41.1	QP	+	GND
0.842000	22.50	10.2	56	33.5	QP	+	GND
0.850000	22.50	10.2	56	33.5	QP	+	GND
2.858000	4.80	10.5	56	51.2	QP	+	GND
7.406000	1.60	10.7	60	58.4	QP	+	GND
25.202000	14.60	11.2	60	45.4	QP	+	GND

MEASUREMENT RESULT: "HTW1129317_fin2"

11/29/2010 3:55PM

Frequency MHz	Level dBμV	Transd dB	Limit dBμV	Margin dB	Detector	Line	PE
0.226000	15.40	10.3	53	37.2	AV	+	GND
0.362000	10.20	10.2	49	38.5	AV	+	GND
0.878000	1.00	10.3	46	45.0	AV	+	GND
2.662000	-0.40	10.5	46	46.4	AV	+	GND
19.666000	10.50	10.9	50	39.5	AV	+	GND
25.202000	14.00	11.2	50	36.0	AV	+	GND

SCAN TABLE: "Voltage (9K-30M)FIN"

Short Description: 150K-30M Voltage

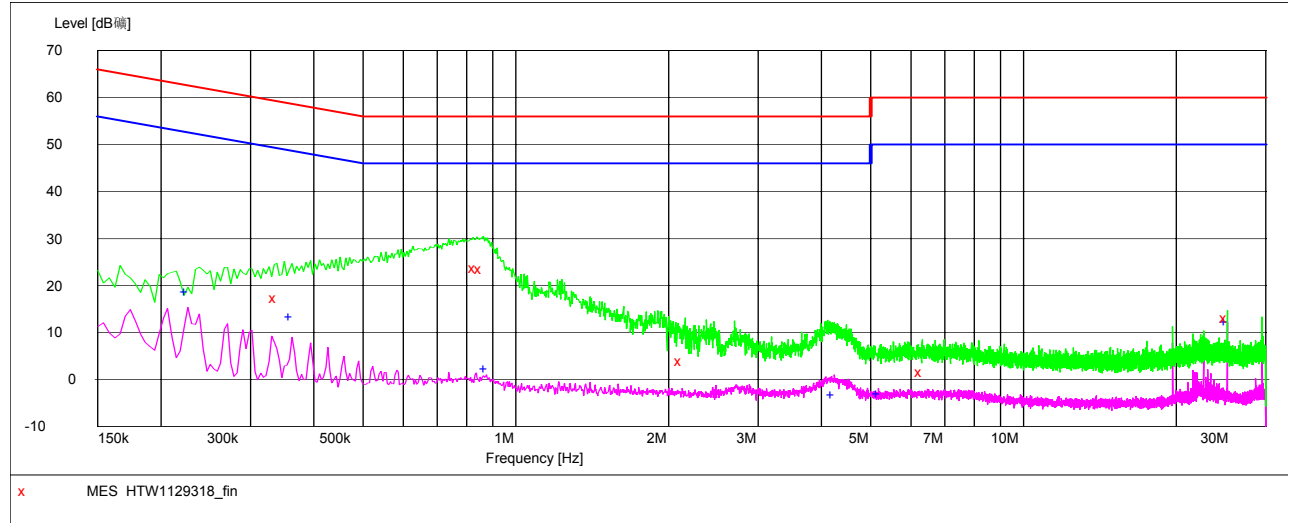

MEASUREMENT RESULT: "HTW1129318_fin"

11/29/2010 3:59PM

Frequency MHz	Level dBμV	Transd dB	Limit dBμV	Margin dB	Detector	Line	PE
0.338000	17.30	10.2	59	42.0	QP	-	GND
0.834000	23.60	10.2	56	32.4	QP	-	GND
0.858000	23.50	10.2	56	32.5	QP	-	GND
2.126000	3.90	10.5	56	52.1	QP	-	GND
6.330000	1.60	10.6	60	58.4	QP	-	GND
25.202000	13.10	11.2	60	46.9	QP	-	GND

MEASUREMENT RESULT: "HTW1129318_fin2"

11/29/2010 3:59PM

Frequency MHz	Level dBμV	Transd dB	Limit dBμV	Margin dB	Detector	Line	PE
0.226000	18.70	10.3	53	33.9	AV	-	GND
0.362000	13.20	10.2	49	35.5	AV	-	GND
0.878000	2.20	10.3	46	43.8	AV	-	GND
4.238000	-3.20	10.6	46	49.2	AV	-	GND
5.202000	-3.10	10.6	50	53.1	AV	-	GND
25.202000	12.20	11.2	50	37.8	AV	-	GND

4.2. Occupied Bandwidth & Emission Mask

TEST APPLICABLE

- (a). Occupied Bandwidth: The EUT was connected to the audio signal generator and the spectrum analyzer via the main RF connector, and through an appropriate attenuator. The EUT was controlled to transmit its maximum power. Then the bandwidth of 99% power can be measured by the spectrum analyzer.
- (b). Emission Mask B: For transmitters that are equipped with an audio low-pass filter pursuant to §90.211(a) and RSS-119 Section 5.8, the power of any emission must be below the unmodulated carrier power (P) as follows:
- (1) On any frequency removed from the assigned frequency by more than 50 percent, but not more than 100 percent of the authorized bandwidth: At least 25 dB.
 - (2) On any frequency removed from the assigned frequency by more than 100 percent, but not more than 250 percent of the authorized bandwidth: At least 35 dB.
 - (3) On any frequency removed from the assigned frequency by more than 250 percent of the authorized bandwidth: At least $43 + 10 \log (P)$ dB.
- (c). Emission Mask D, 12.5 kHz channel bandwidth equipment: For transmitters designed to operate with a 12.5 kHz channel bandwidth, any emission must be attenuated below the power (P) of the highest emission contained within the authorized bandwidth as follows:
- (1) On any frequency from the center of the authorized bandwidth f_0 to 5.625 kHz removed from f_0 : Zero dB.
 - (2) On any frequency removed from the center of the authorized bandwidth by a displacement frequency (f_d in kHz) of more than 5.625 kHz but no more than 12.5 kHz: At least $7.27(f_d - 2.88 \text{ kHz})$ dB.
 - (3) On any frequency removed from the center of the authorized bandwidth by a displacement frequency (f_d in kHz) of more than 12.5 kHz: At least $50 + 10 \log (P)$ dB or 70 dB, whichever is the lesser attenuation.

TEST CONFIGURATION

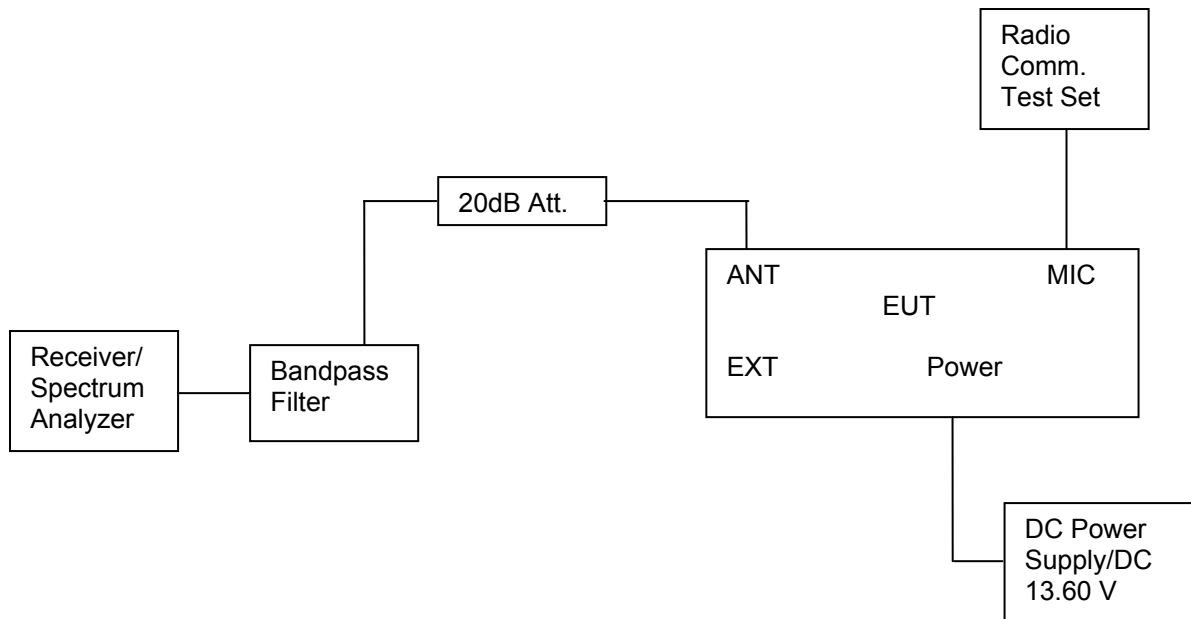

TEST PROCEDURE

- 1 The EUT was placed on a turn table which is 0.8m above ground plane.
- 2 The EUT was modulated by 2.5 KHz Sine wave audio signal, The level of the audio signal employed is 16 dB greater than that necessary to produce 50% of rated system deviation. Rated system deviation is 2.5 kHz (12.5 kHz channel spacing) and 5 kHz (25 kHz channel spacing).
- 3 Set EUT as normal operation.
- 4 Set SPA Center Frequency = fundamental frequency, RBW=300Hz, VBW= 3 KHz, span =50 KHz.
- 5 Set SPA Max hold. Mark peak, Set 99% Occupied Bandwidth and 26dB Occupied Bandwidth.

TEST RESULTS

4.2.1 Occupied Bandwidth

Modulation type	Certification type	Channel Separation	Test Channel	Test Frequency	99% Occupied Bandwidth	26dB Occupied Band width
FM	FCC	25KHz	Low	438.1250 MHz	10.62 KHz	15.63 KHz
			Middle	464.1250 MHz	10.52 KHz	15.53 KHz
			High	489.9875 MHz	10.62 KHz	15.63 KHz
		12.5KHz	Low	438.1250 MHz	7.72 KHz	10.42 KHz
			Middle	464.1250 MHz	5.91 KHz	10.42 KHz
			High	489.9875 MHz	5.71 KHz	10.42 KHz
	IC	25KHz	Low	450.1250 MHz	10.52 KHz	15.53 KHz
			Middle	460.1250 MHz	10.52 KHz	15.53 KHz
			High	469.9875 MHz	10.52 KHz	15.53 KHz
		12.5KHz	Low	450.1250 MHz	5.81 KHz	10.42 KHz
			Middle	460.1250 MHz	5.71 KHz	10.42 KHz
			High	469.9875 MHz	5.71 KHz	10.42 KHz
Limit		20kHz for 25kHz Channel Separation				
Limit		11.25kHz for 12.5kHz Channel Separation				
Test Results		Compliance				

Plots of 99% and 26dB Bandwidth Measurement

For FCC

Modulation Type	Channel Separation	Freq.(MHz)	99% Bandwidth (KHz)	26dB Bandwidth (KHz)	FCC Limit (KHz)	Results
FM	25 KHz	438.1250	10.62	15.63	20	Compliance

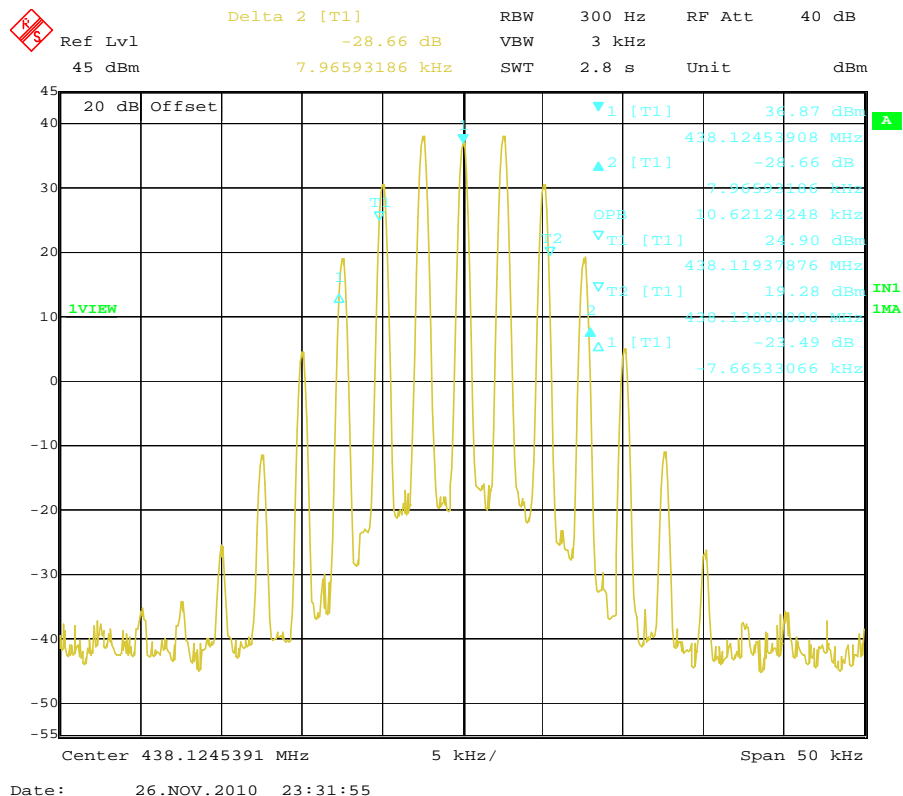

Modulation Type	Channel Separation	Freq.(MHz)	99% Bandwidth (KHz)	26dB Bandwidth (KHz)	FCC Limit (KHz)	Results
FM	25 KHz	464.1250	10.52	15.53	20	Compliance

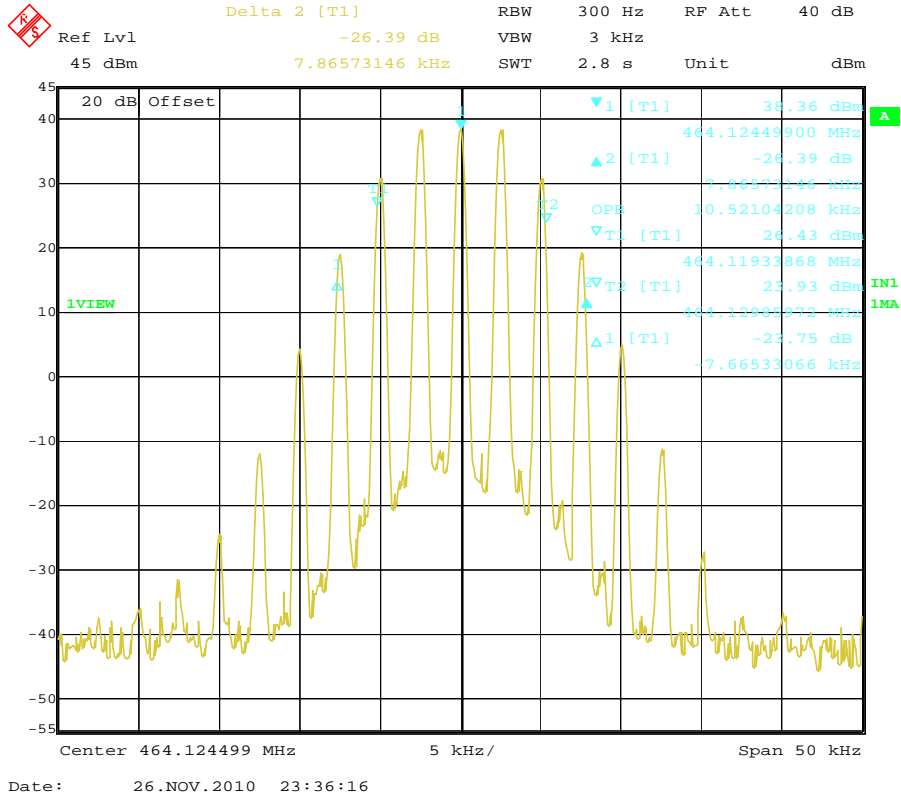

Modulation Type	Channel Separation	Freq.(MHz)	99% Bandwidth (KHz)	26dB Bandwidth (KHz)	FCC Limit (KHz)	Results
FM	25 KHz	489.9875	10.62	15.63	20	Compliance

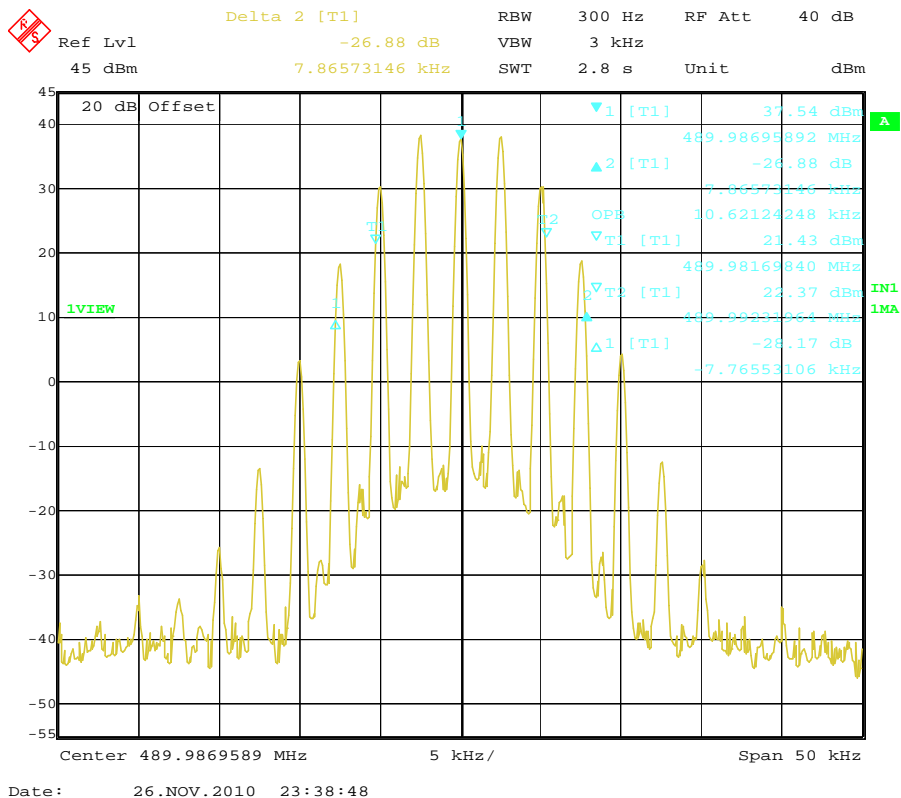

Modulation Type	Channel Separation	Freq.(MHz)	99% Bandwidth (KHz)	26dB Bandwidth (KHz)	FCC Limit (KHz)	Results
FM	12.5 KHz	438.1250	7.72	10.42	11.25	Compliance

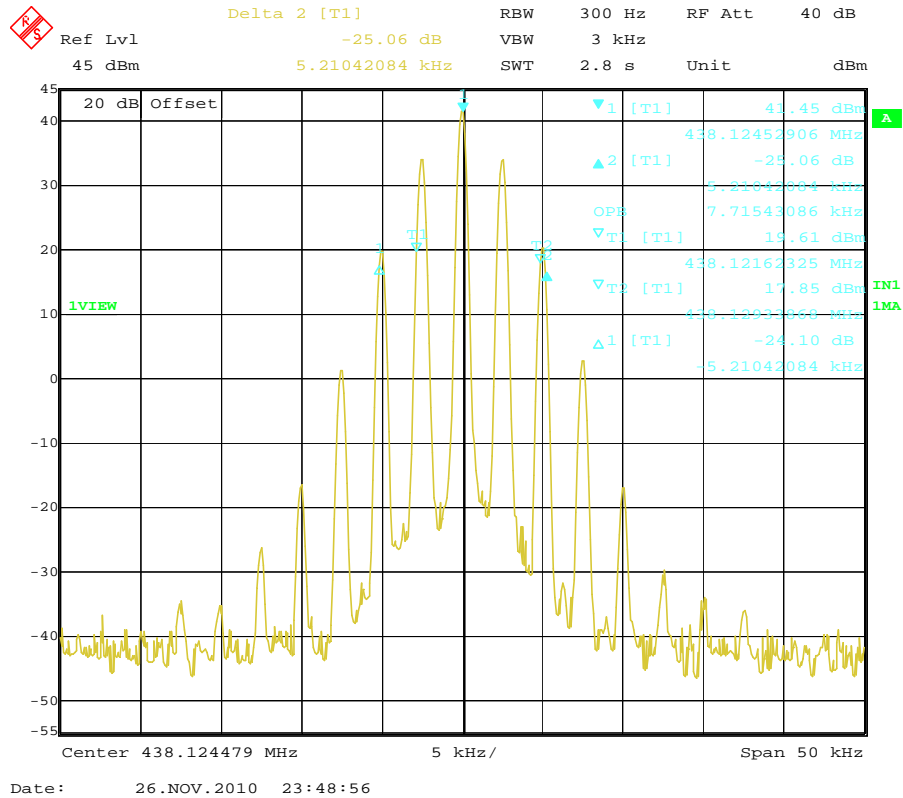

Modulation Type	Channel Separation	Freq.(MHz)	99% Bandwidth (KHz)	26dB Bandwidth (KHz)	FCC Limit (KHz)	Results
FM	12.5 KHz	464.1250	5.91	10.42	11.25	Compliance

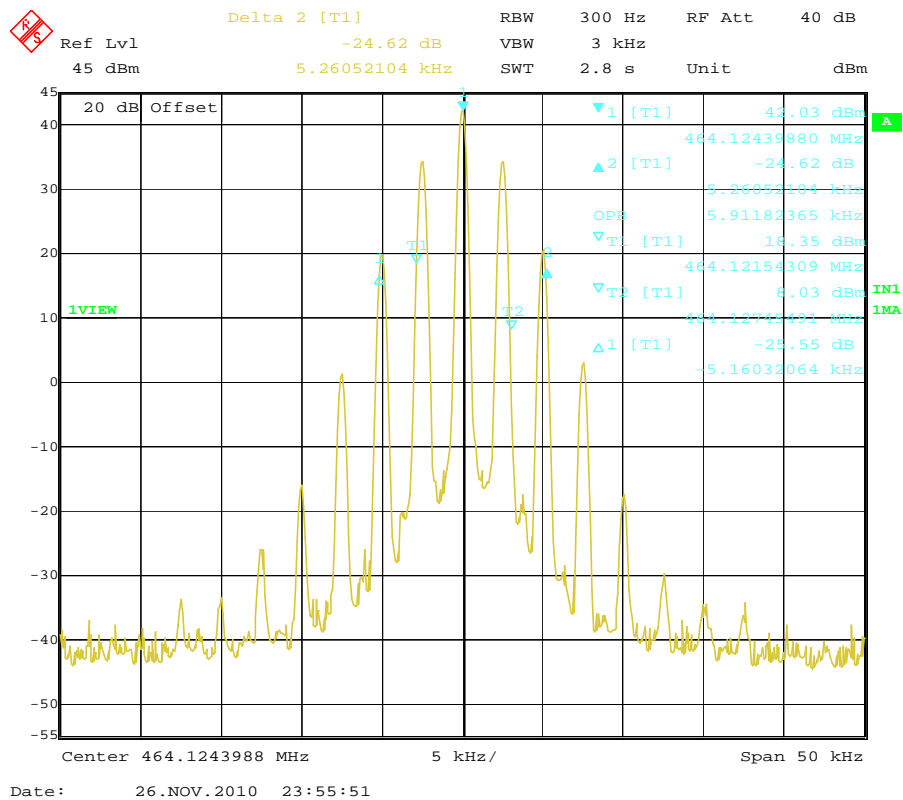

Modulation Type	Channel Separation	Freq.(MHz)	99% Bandwidth (KHz)	26dB Bandwidth (KHz)	FCC Limit (KHz)	Results
FM	12.5 KHz	489.9875	5.71	10.42	11.25	Compliance

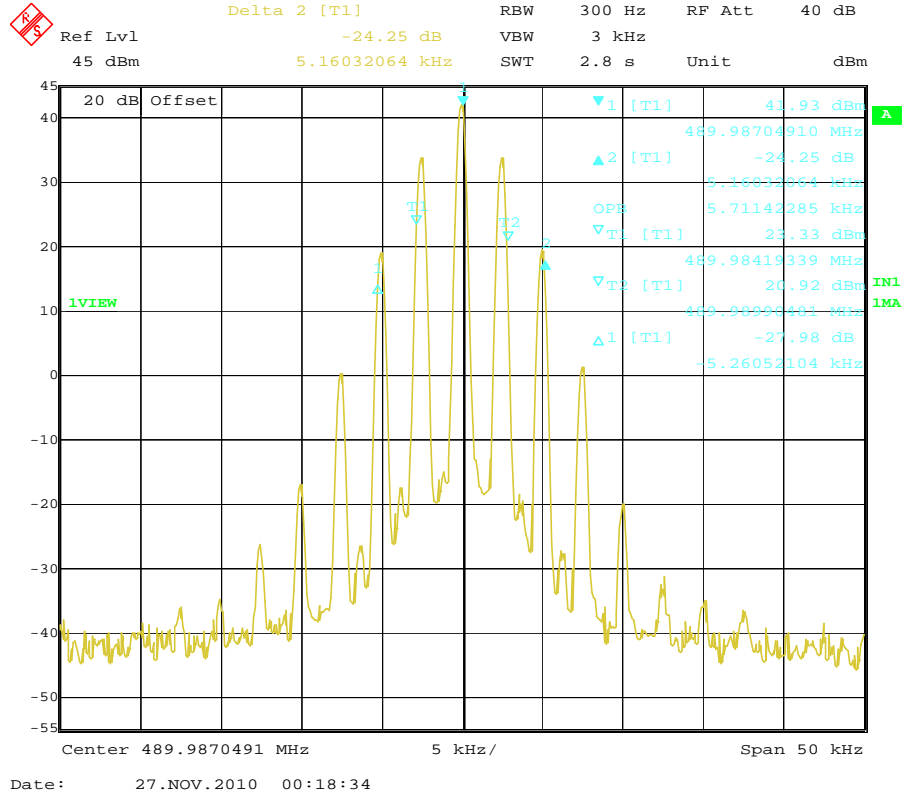

For IC

Modulation Type	Channel Separation	Freq.(MHz)	99% Bandwidth (KHz)	26dB Bandwidth (KHz)	FCC Limit (KHz)	Results
FM	25 KHz	450.1250	10.52	15.53	20	Compliance

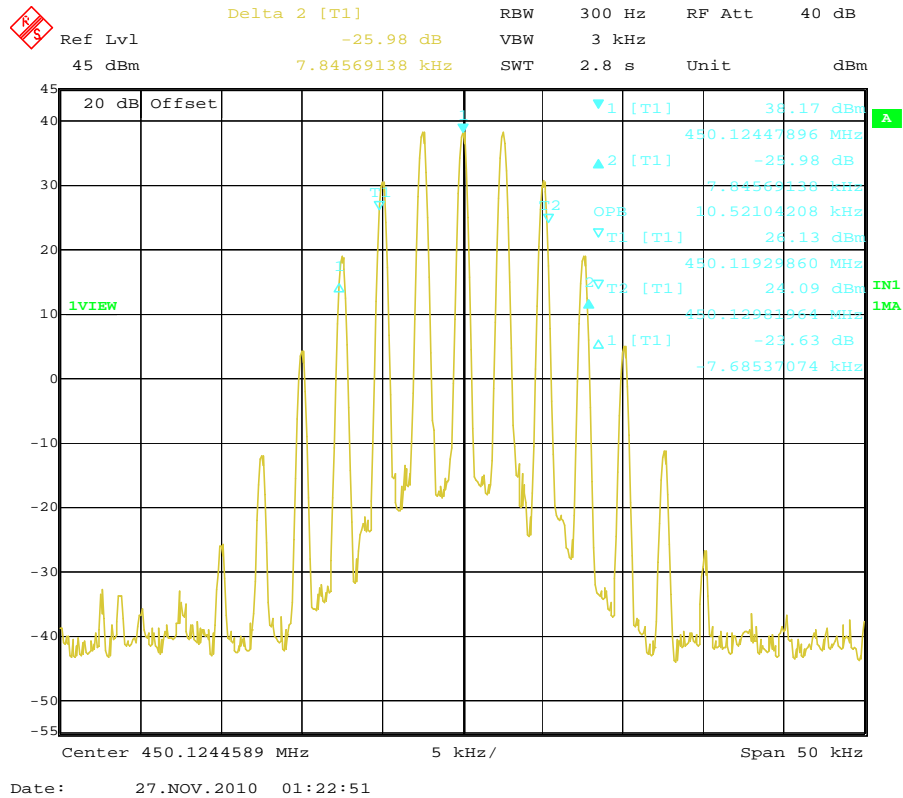

Modulation Type	Channel Separation	Freq.(MHz)	99% Bandwidth (KHz)	26dB Bandwidth (KHz)	FCC Limit (KHz)	Results
FM	25 KHz	460.1250	10.52	15.53	20	Compliance

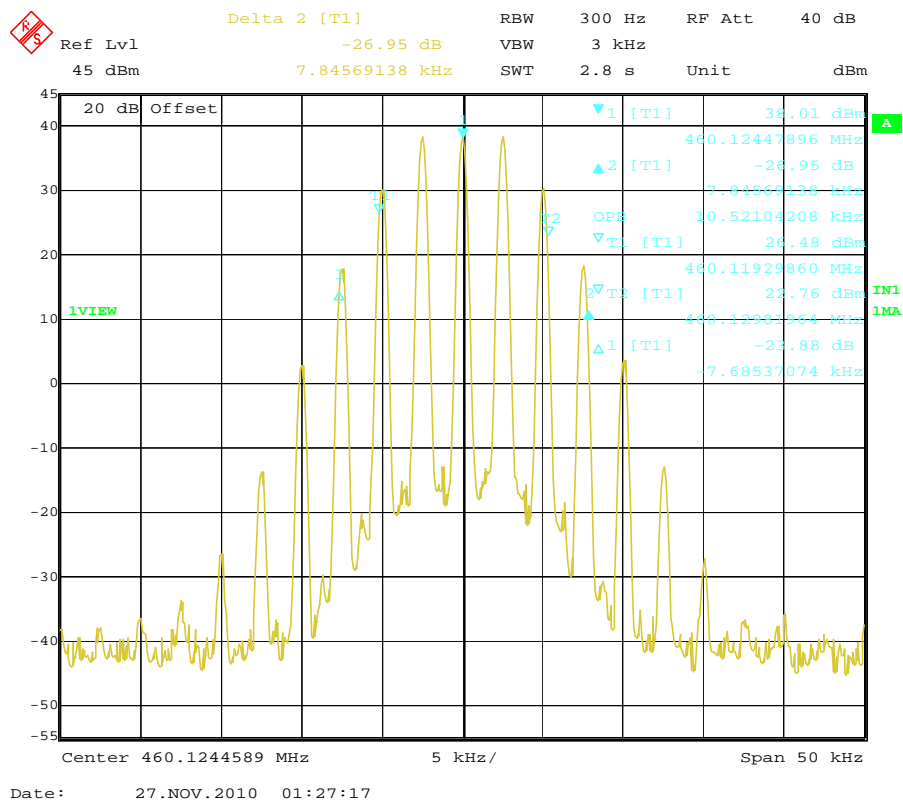

Modulation Type	Channel Separation	Freq.(MHz)	99% Bandwidth (KHz)	26dB Bandwidth (KHz)	FCC Limit (KHz)	Results
FM	25 KHz	469.9875	10.52	15.53	20	Compliance

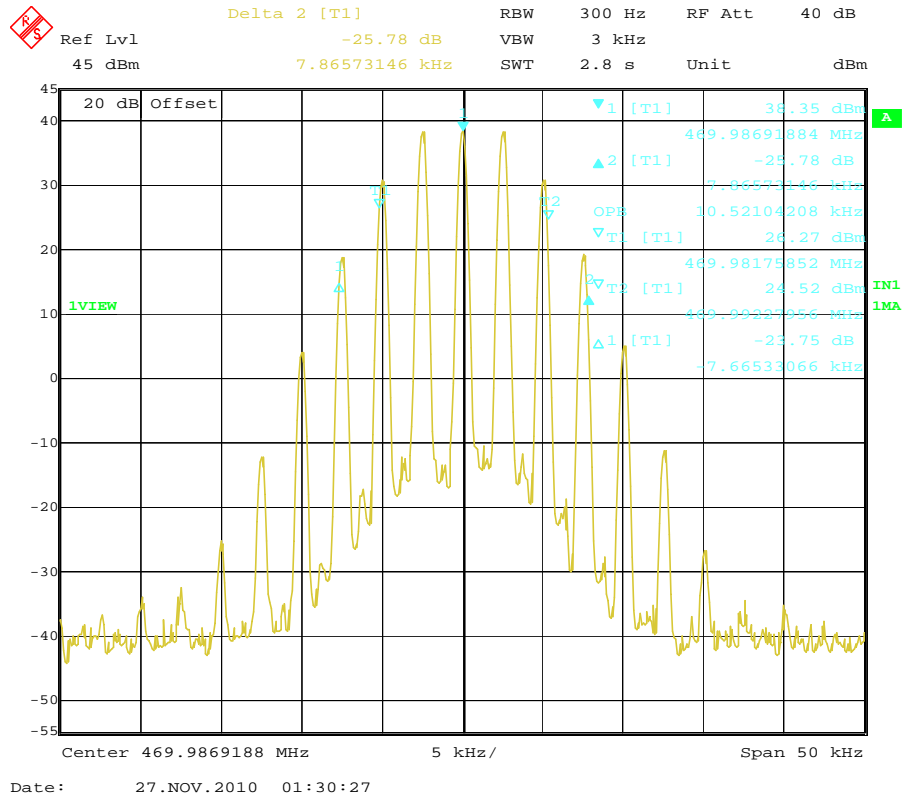

Modulation Type	Channel Separation	Freq.(MHz)	99% Bandwidth (KHz)	26dB Bandwidth (KHz)	FCC Limit (KHz)	Results
FM	12.5 KHz	450.1250	5.81	10.42	11.25	Compliance

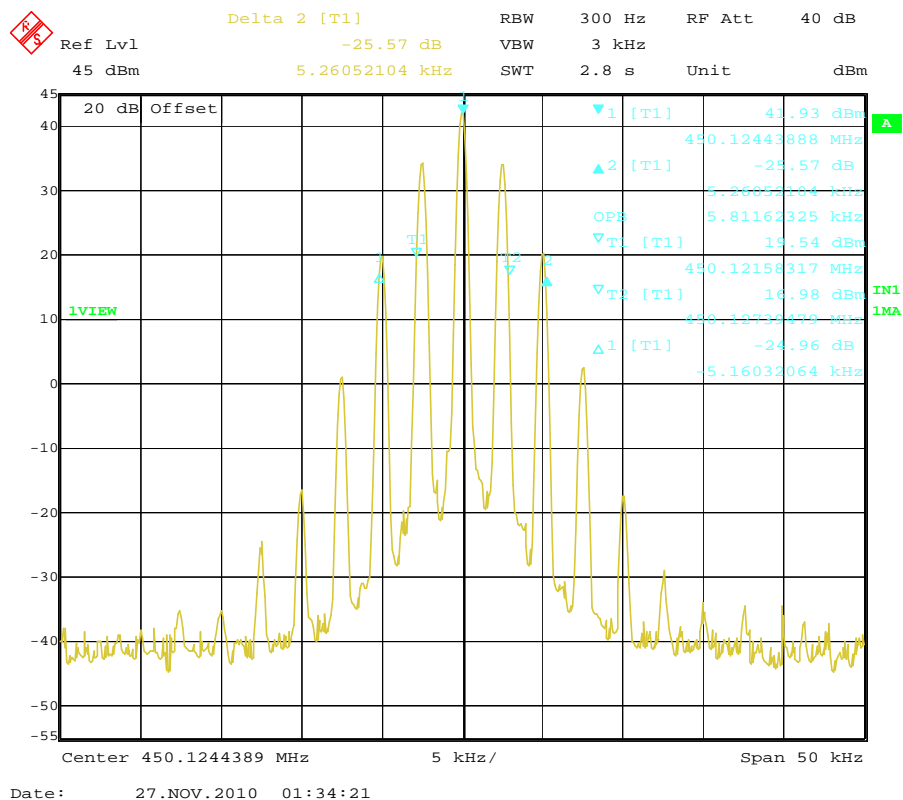

Modulation Type	Channel Separation	Freq.(MHz)	99% Bandwidth (KHz)	26dB Bandwidth (KHz)	FCC Limit (KHz)	Results
FM	12.5 KHz	460.1250	5.71	10.42	11.25	Compliance

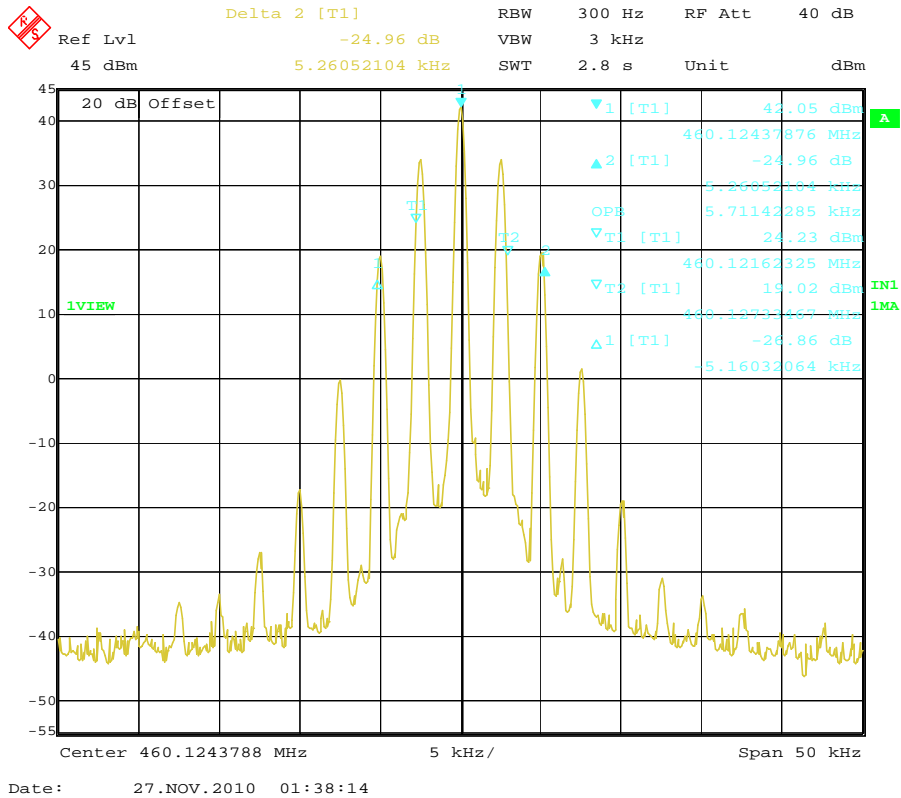

Modulation Type	Channel Separation	Freq.(MHz)	99% Bandwidth (KHz)	26dB Bandwidth (KHz)	FCC Limit (KHz)	Results
FM	12.5 KHz	469.9875	5.71	10.42	11.25	Compliance

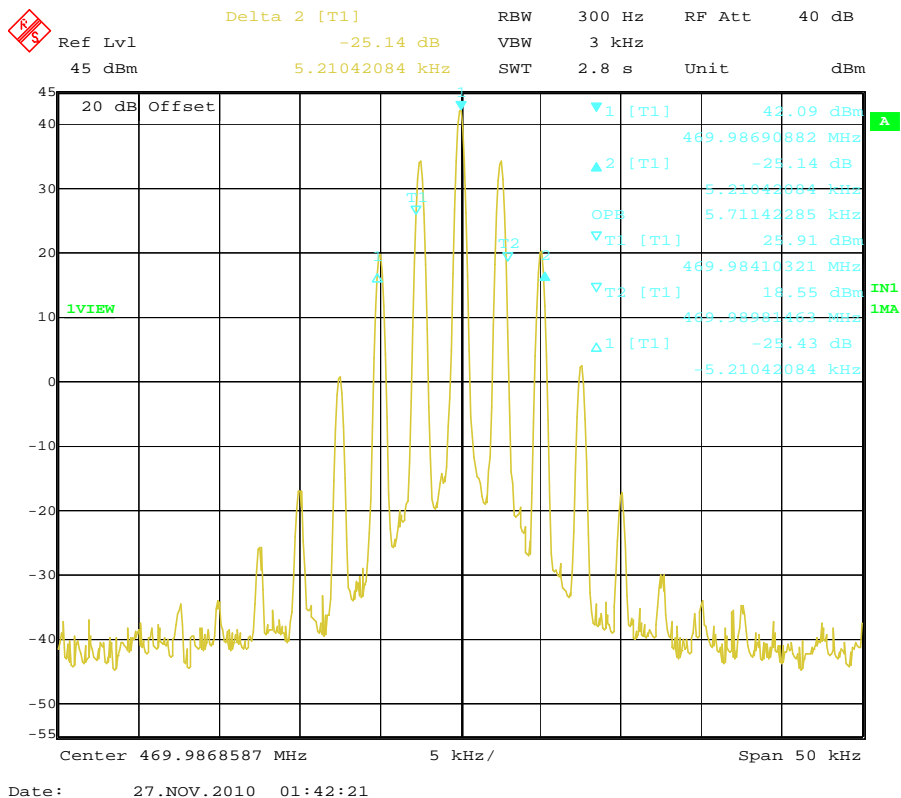

4.2.2 Emission Mask

Modulation type	Certification type	Channel Separation	Test Channel	Test Frequency	FCC Applicable Mask	RBW
FM	FCC	25KHz	Low	438.1250 MHz	B	300Hz
			Middle	464.1250 MHz	B	300Hz
			High	489.1250 MHz	B	300Hz
		12.5KHz	Low	438.1250 MHz	D	100Hz
			Middle	464.1250 MHz	D	100Hz
			High	489.1250 MHz	D	100Hz
	IC	25KHz	Low	450.1250 MHz	B	300Hz
			Middle	460.1250 MHz	B	300Hz
			High	469.9875 MHz	B	300Hz
		12.5KHz	Low	450.1250 MHz	D	100Hz
			Middle	460.1250 MHz	D	100Hz
			High	469.9875 MHz	D	100Hz
Test Results			Compliance			

Plots of Emission Mask Measurement

Referred as the attached plot hereinafter

Note: The yellow curve represents unmodulated signal.

The green curve represents modulated signal.

For FCC

Modulation Type	Channel Separation	Freq.(MHz)	FCC Applicable Mask	RBW	Audio Freq. (KHz)	Results
FM	25 KHz	438.1250	B	300Hz	2.5	Compliance

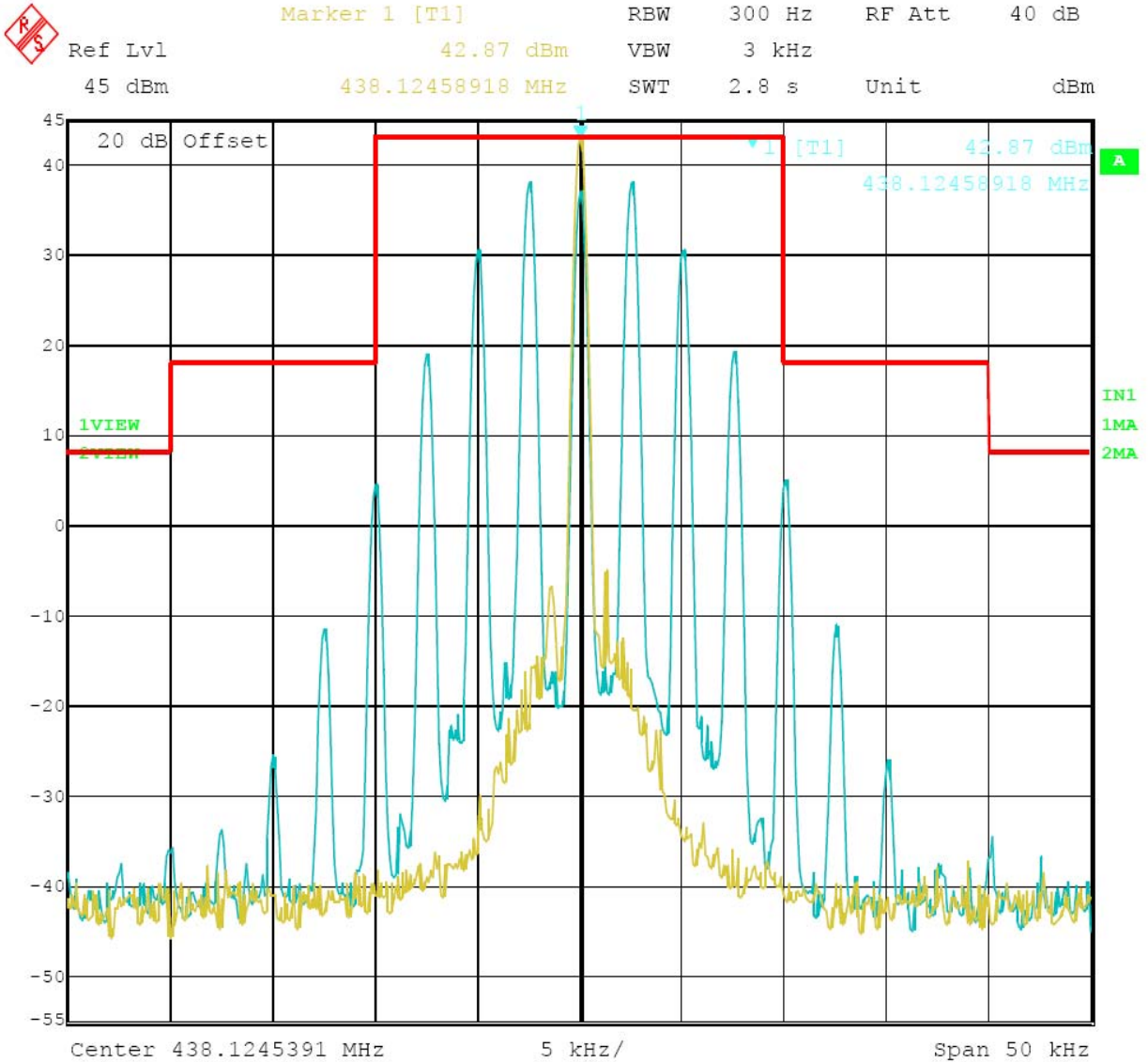

Date: 26.NOV.2010 23:33:18
 25 kHz Channel Spacing, 438.1250 MHz, 2500 Hz Audio Modulation Only

Modulation Type	Channel Separation	Freq.(MHz)	FCC Applicable Mask	RBW	Audio Freq. (KHz)	Results
FM	25 KHz	464.1250	B	300Hz	2.5	Compliance

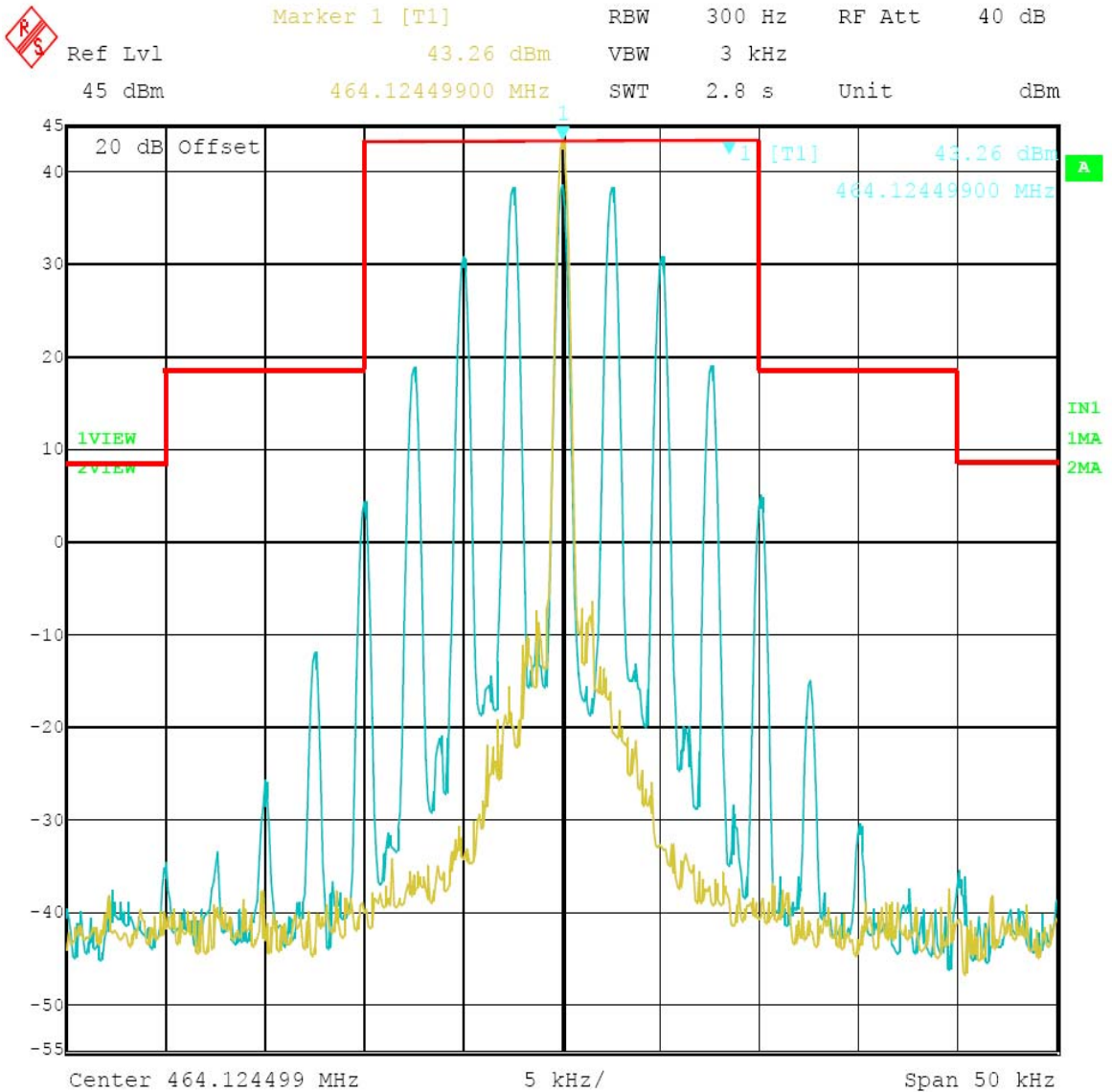

Date: 26.NOV.2010 23:35:33

25 kHz Channel Spacing, 464.1250 MHz, 2500 Hz Audio Modulation Only

Modulation Type	Channel Separation	Freq.(MHz)	FCC Applicable Mask	RBW	Audio Freq. (KHz)	Results
FM	25 KHz	489.9875	B	300Hz	2.5	Compliance

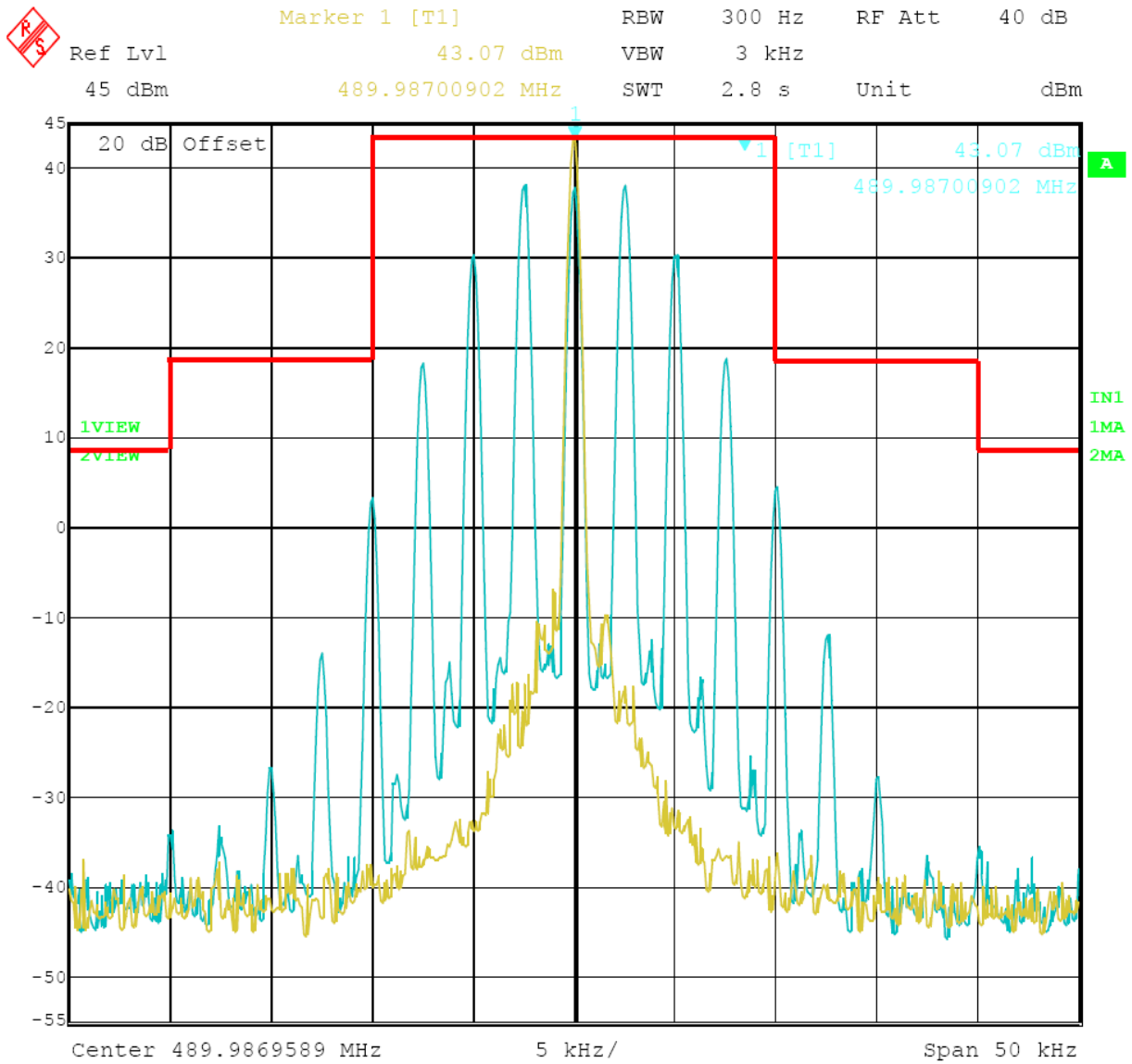

Date: 26.NOV.2010 23:40:19

25 kHz Channel Spacing, 489.9875 MHz, 2500 Hz Audio Modulation Only

Modulation Type	Channel Separation	Freq.(MHz)	FCC Applicable Mask	RBW	Audio Freq. (KHz)	Results
FM	12.5 KHz	438.1250	D	100Hz	2.5	Compliance

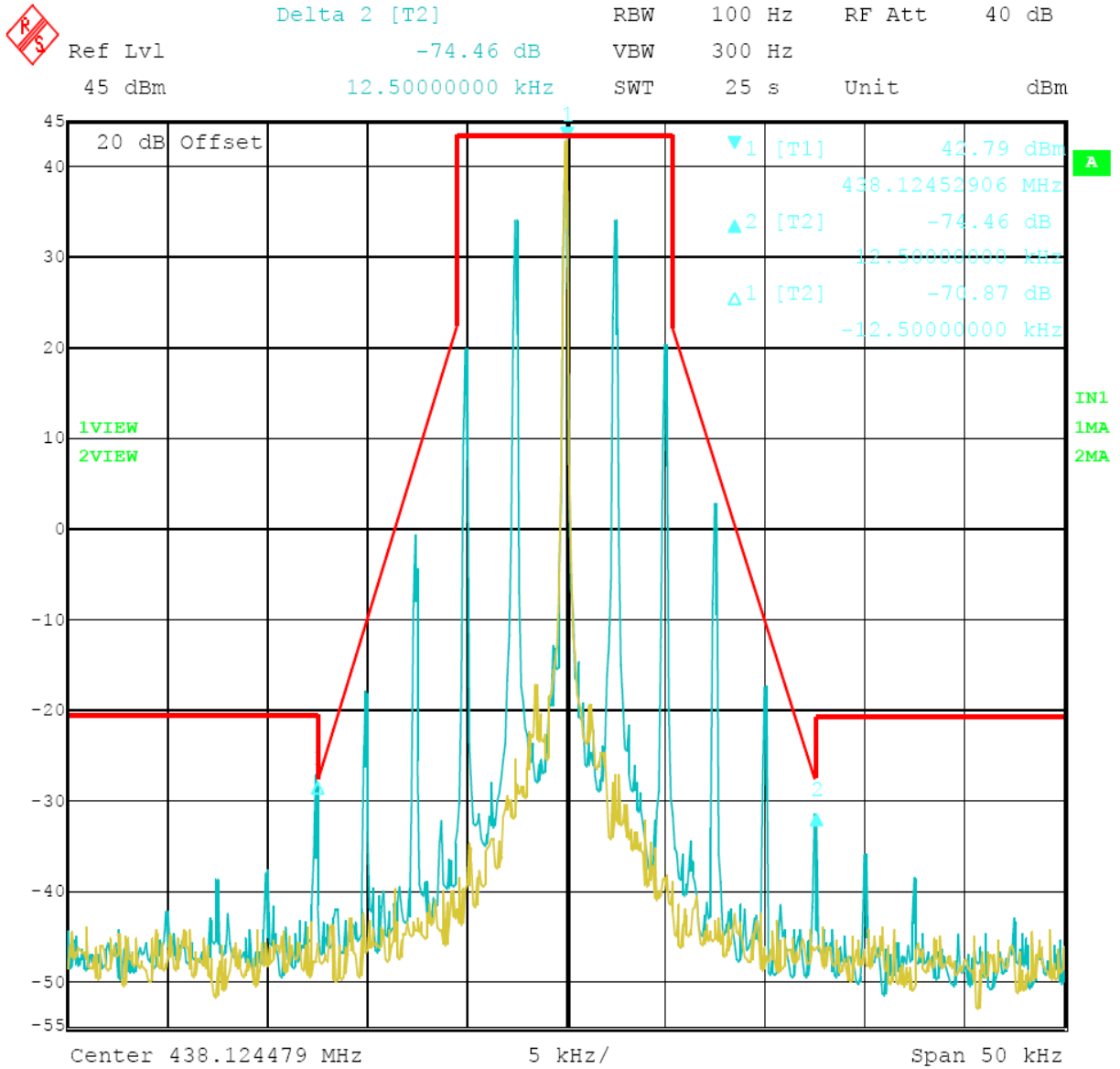

12.5 kHz Channel Spacing, 438.1250 MHz, 2500 Hz Audio Modulation Only

Modulation Type	Channel Separation	Freq.(MHz)	FCC Applicable Mask	RBW	Audio Freq. (KHz)	Results
FM	12.5 KHz	464.1250	D	100Hz	2.5	Compliance

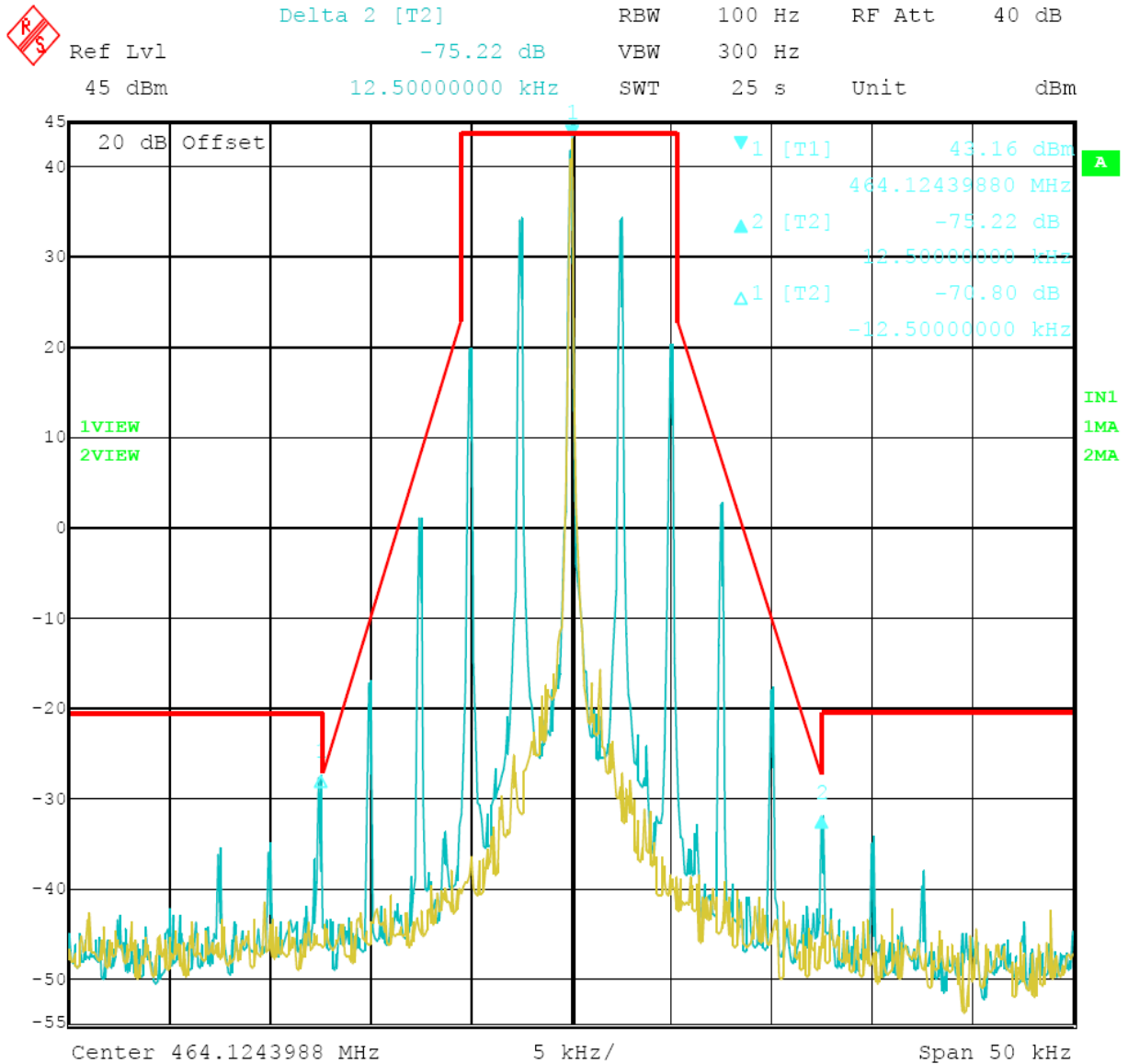

Date: 26.NOV.2010 23:54:54

12.5 kHz Channel Spacing, 464.1250 MHz, 2500 Hz Audio Modulation Only

Modulation Type	Channel Separation	Freq.(MHz)	FCC Applicable Mask	RBW	Audio Freq. (KHz)	Results
FM	12.5 KHz	489.9875	D	100Hz	2.5	Compliance

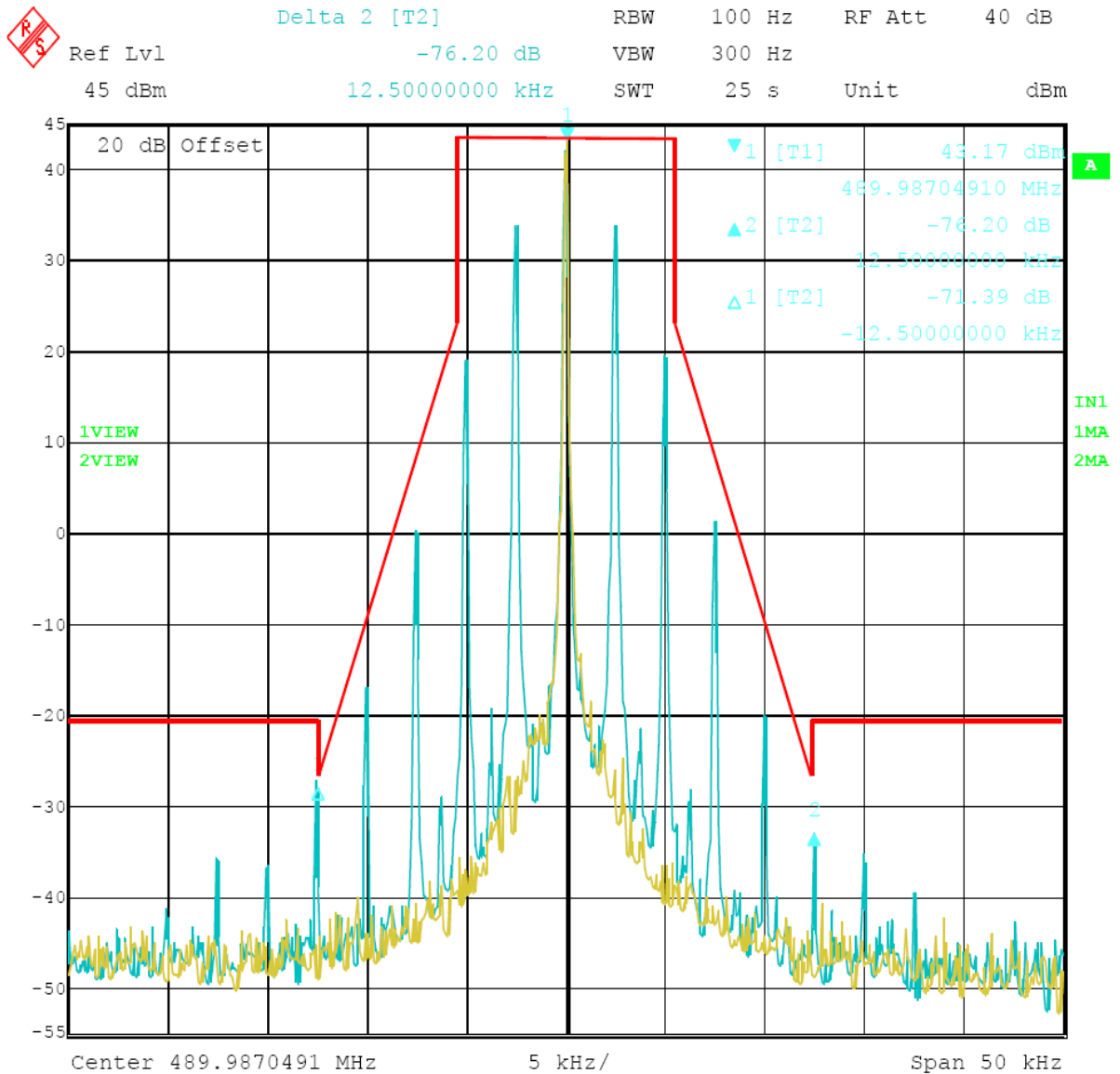

Date: 27.NOV.2010 00:16:50

12.5 kHz Channel Spacing, 489.9875 MHz, 2500 Hz Audio Modulation Only

For IC

Modulation Type	Channel Separation	Freq.(MHz)	FCC Applicable Mask	RBW	Audio Freq. (KHz)	Results
FM	25 KHz	450.1250	B	300Hz	2.5	Compliance

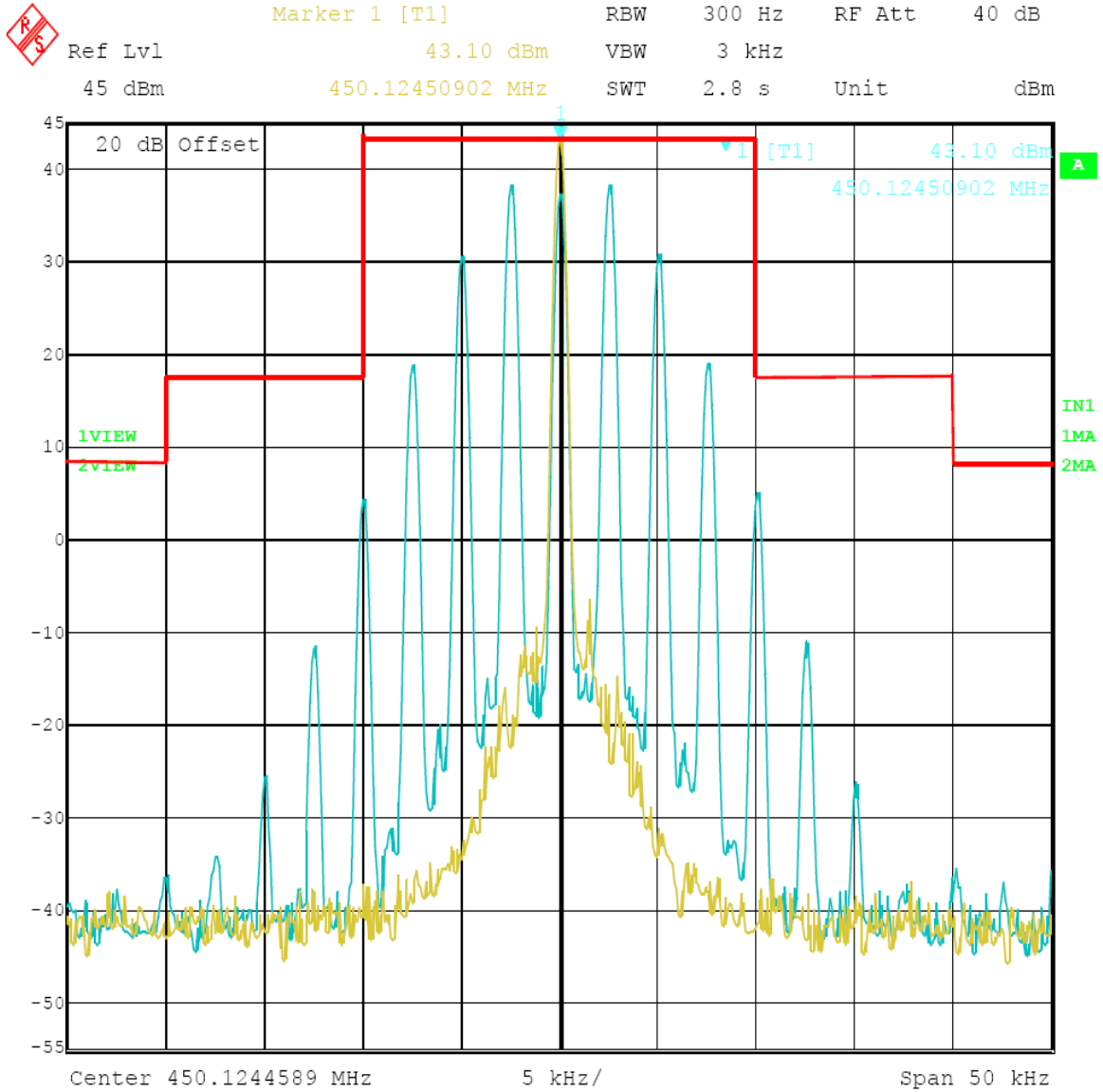

Date: 27.NOV.2010 01:24:01
 25 kHz Channel Spacing, 450.1250 MHz, 2500 Hz Audio Modulation Only

Modulation Type	Channel Separation	Freq.(MHz)	FCC Applicable Mask	RBW	Audio Freq. (KHz)	Results
FM	25 KHz	460.1250	B	300Hz	2.5	Compliance

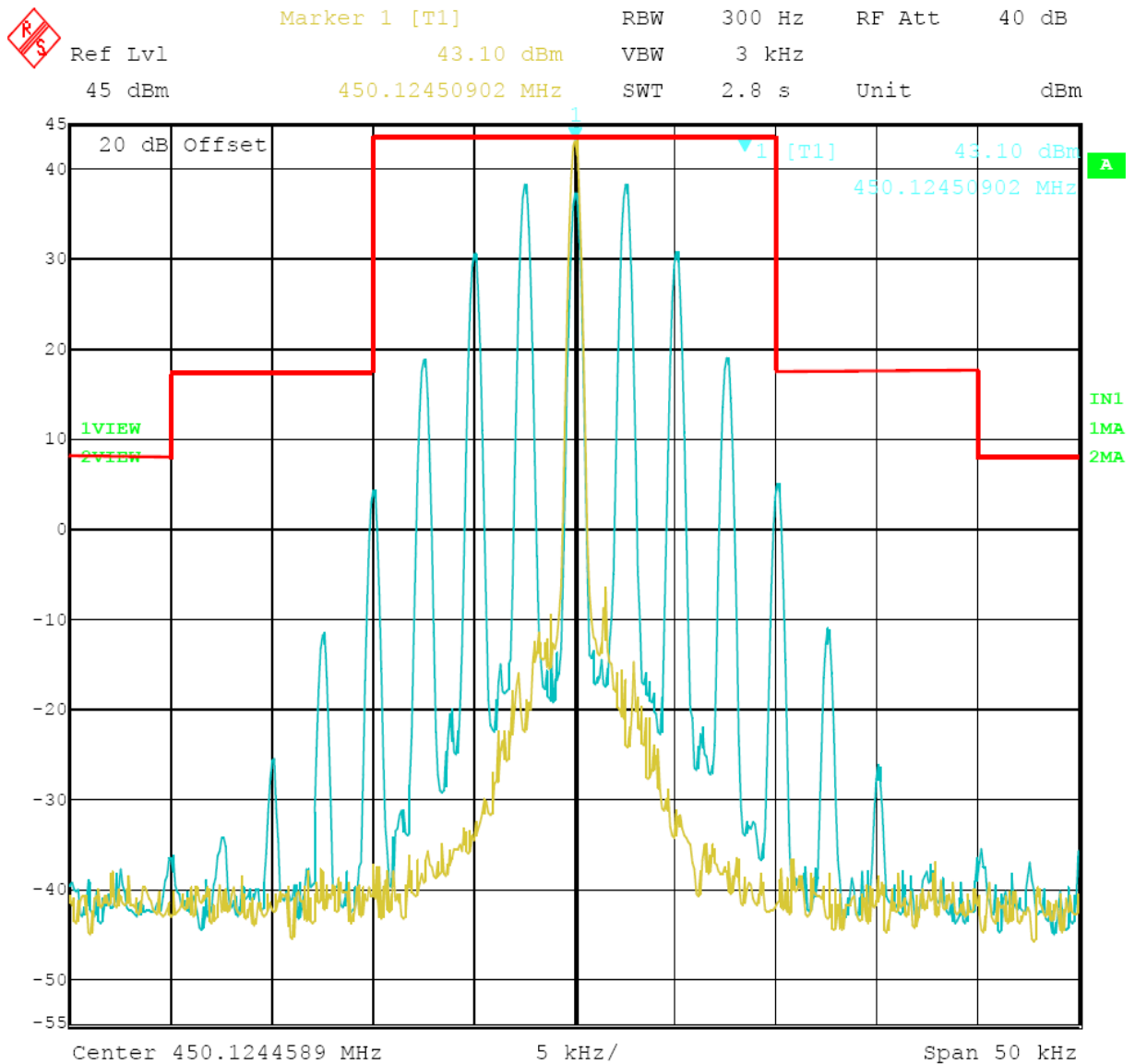

Date: 27.NOV.2010 01:24:01

25 kHz Channel Spacing, 460.1250 MHz, 2500 Hz Audio Modulation Only

Modulation Type	Channel Separation	Freq.(MHz)	FCC Applicable Mask	RBW	Audio Freq. (KHz)	Results
FM	25 KHz	469.9875	B	300Hz	2.5	Compliance

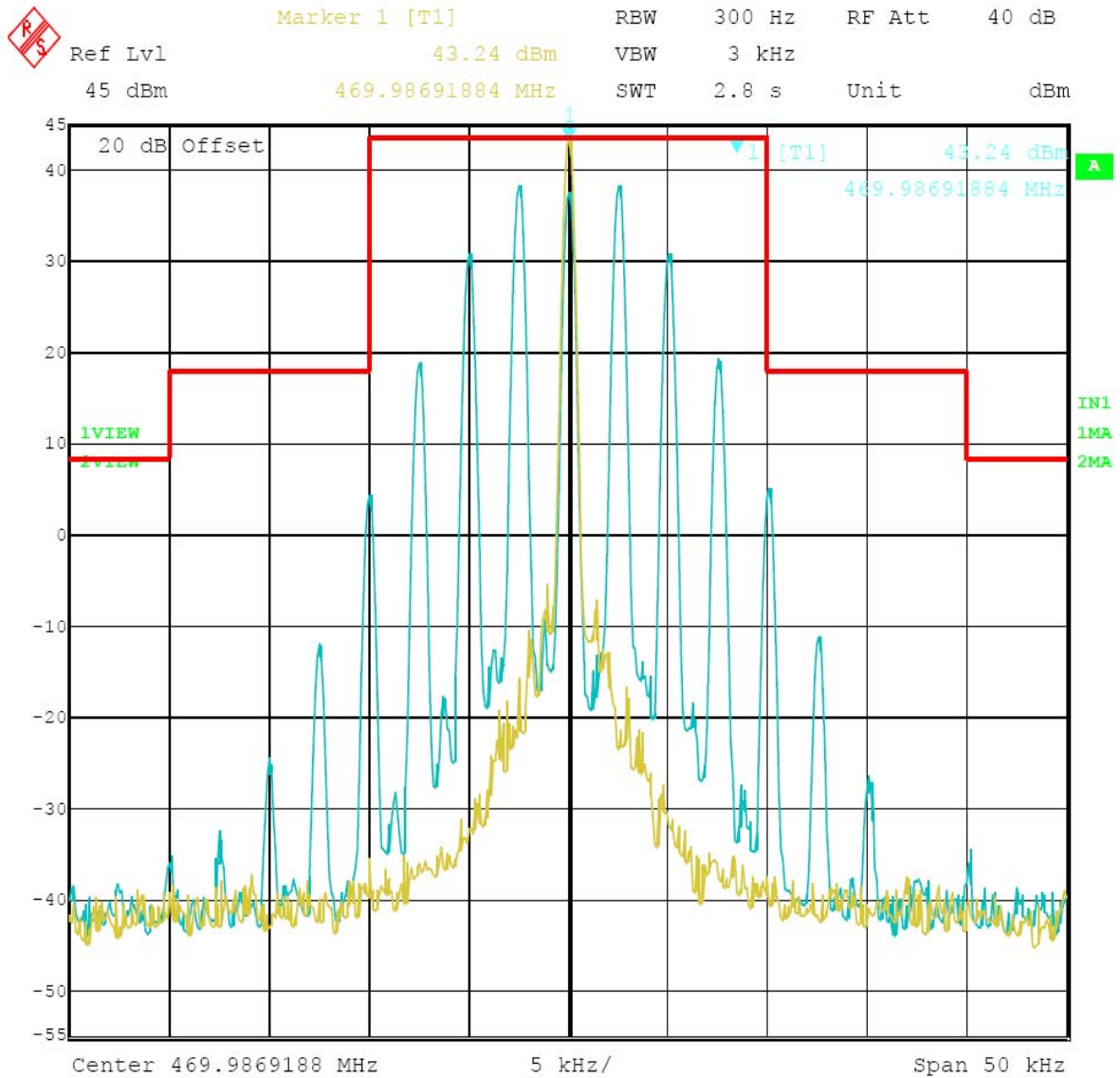

Date: 27.NOV.2010 01:29:37

25 kHz Channel Spacing, 469.9875 MHz, 2500 Hz Audio Modulation Only

Modulation Type	Channel Separation	Freq.(MHz)	FCC Applicable Mask	RBW	Audio Freq. (KHz)	Results
FM	12.5 KHz	450.1250	D	100Hz	2.5	Compliance

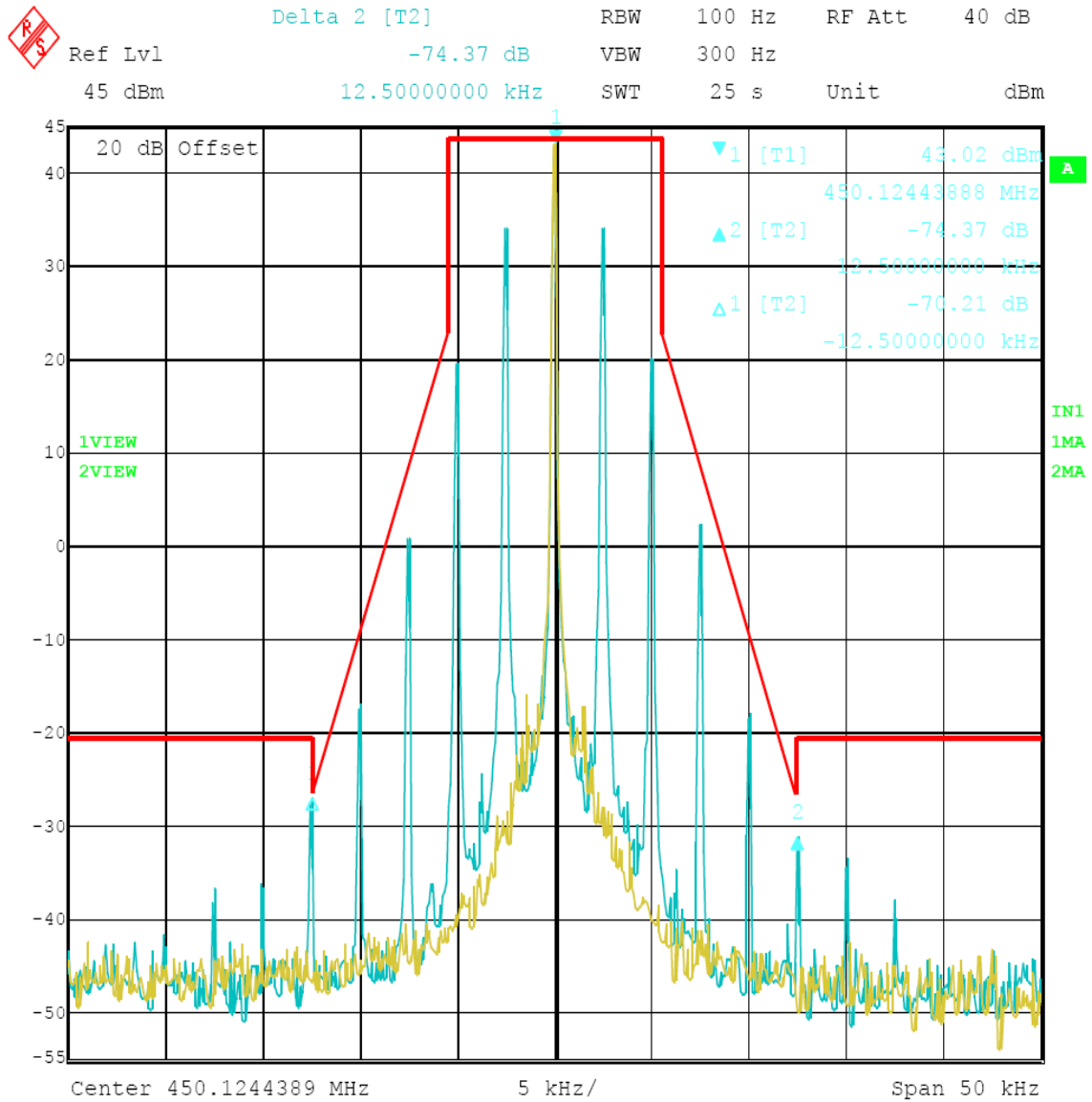

Date: 27.NOV.2010 01:33:29

12.5 kHz Channel Spacing, 450.1250 MHz, 2500 Hz Audio Modulation Only

Modulation Type	Channel Separation	Freq.(MHz)	FCC Applicable Mask	RBW	Audio Freq. (KHz)	Results
FM	12.5 KHz	460.1250	D	100Hz	2.5	Compliance

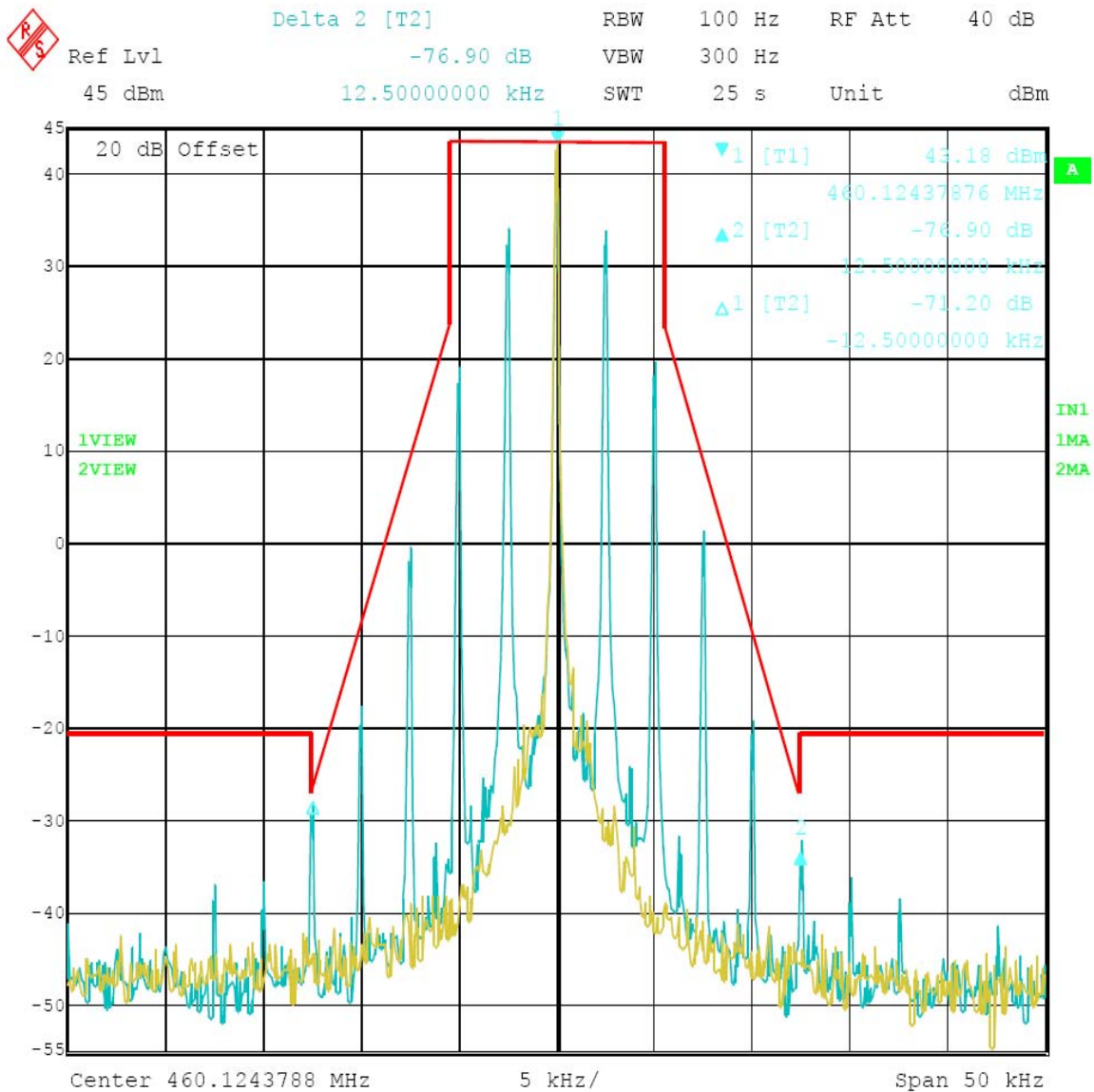

Date: 27.NOV.2010 01:37:11

12.5 kHz Channel Spacing, 460.1250 MHz, 2500 Hz Audio Modulation Only

Modulation Type	Channel Separation	Freq.(MHz)	FCC Applicable Mask	RBW	Audio Freq. (KHz)	Results
FM	12.5 KHz	469.9875	D	100Hz	2.5	Compliance

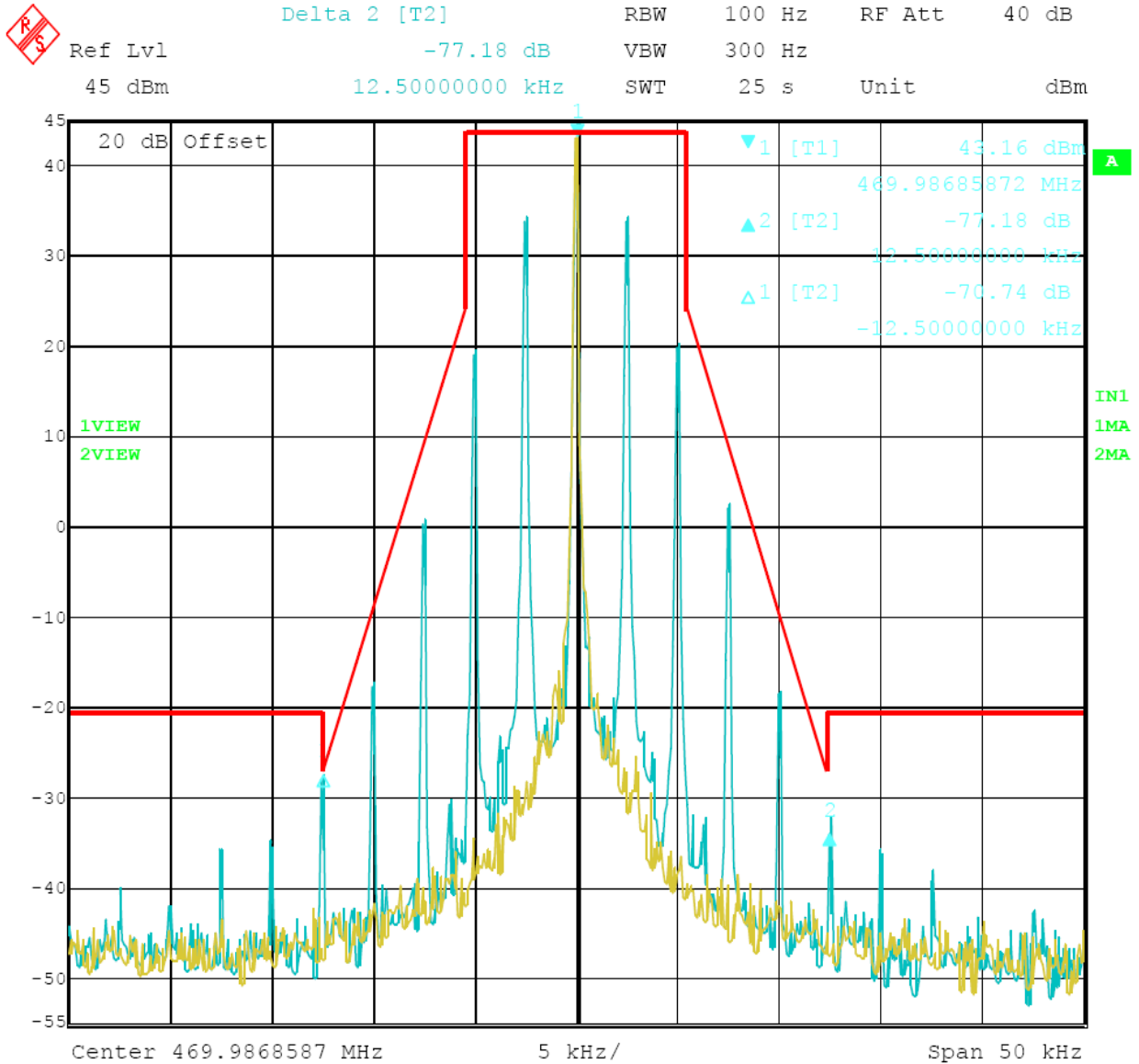

Date: 27.NOV.2010 01:41:29

12.5 kHz Channel Spacing, 469.9875 MHz, 2500 Hz Audio Modulation Only

4.3. Transmitter Radiated Spurious Emission

TEST APPLICABLE

According to the TIA/EIA 603 test method, and according to Section 90.210 and RSS-119 Section 5.8, the power of each unwanted emission shall be less than Transmitted Power as specified below for transmitters designed to operate with 12.5 KHz channel bandwidth:

- 1 On any frequency removed from the center of the authorized bandwidth f_0 to 5.625 KHz removed from f_0 : Zero dB
 - 2 On any frequency removed from the center of the authorized bandwidth by a displacement frequency (f_d in KHz) f_0 of more than 5.625 KHz but no more than 12.5 KHz: At least 7.27dB
 - 3 On any frequency removed from the center of the authorized bandwidth by a displacement frequency (f_d in KHz) f_0 of more than 12.5 KHz: At least $50 + 10 \log(P)$ dB or 70 dB, which ever is lesser attenuation.
- For transmitters designed to transmit with 25 KHz channel separation and equipped with an audio low-pass filter, the power of any emission must be attenuated below the unmodulated carrier power (P) as following:

- 1 On any frequency removed from the assigned frequency by more than 50 percent, but no more than 100 percent of the authorized bandwidth: At least 25 dB.
- 2 On any frequency removed from the assigned frequency by more than 100 percent, but no more than 250 percent of the authorized bandwidth: At least 35 dB.
- 3 On any frequency removed from the assigned frequency by more than 250 percent of the authorized bandwidth: At least $43 + 10 \log(P)$ dB.

TEST CONFIGURATION

Below 1GHz

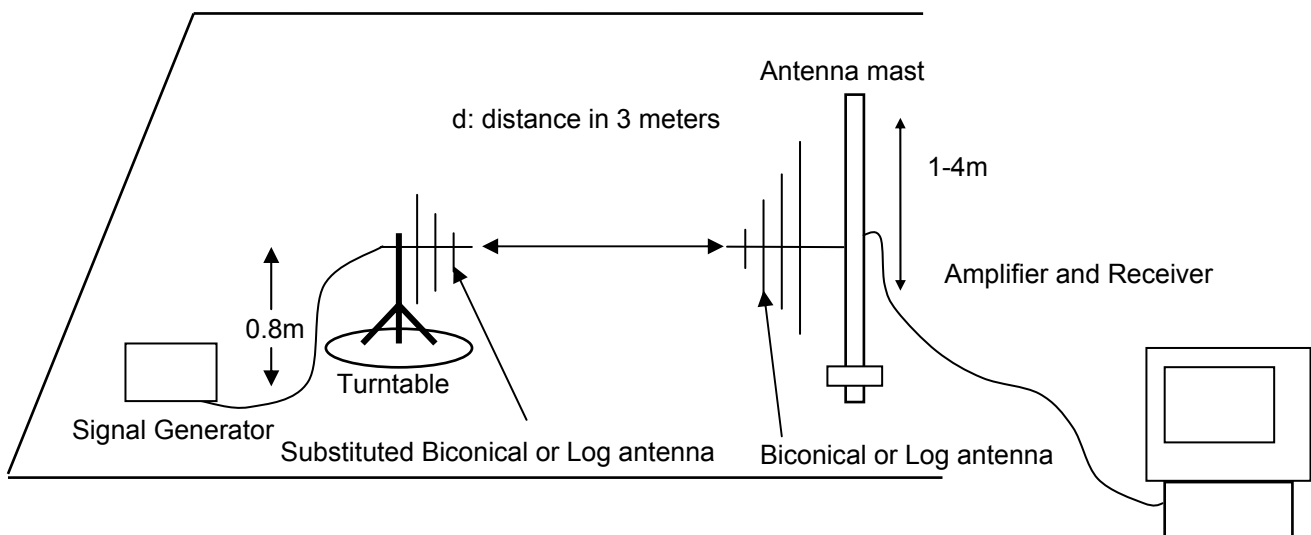
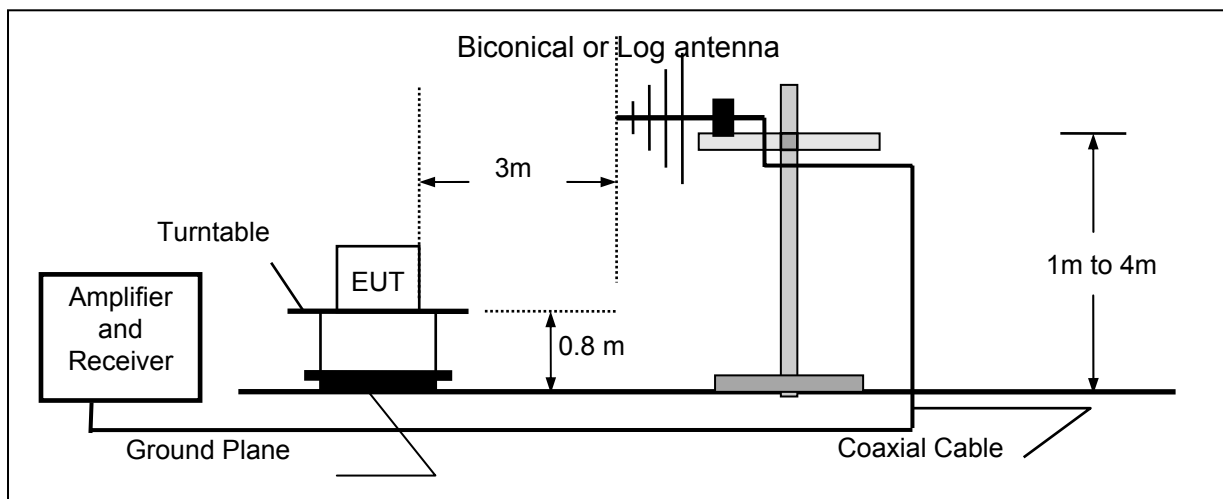

Above 1GHz

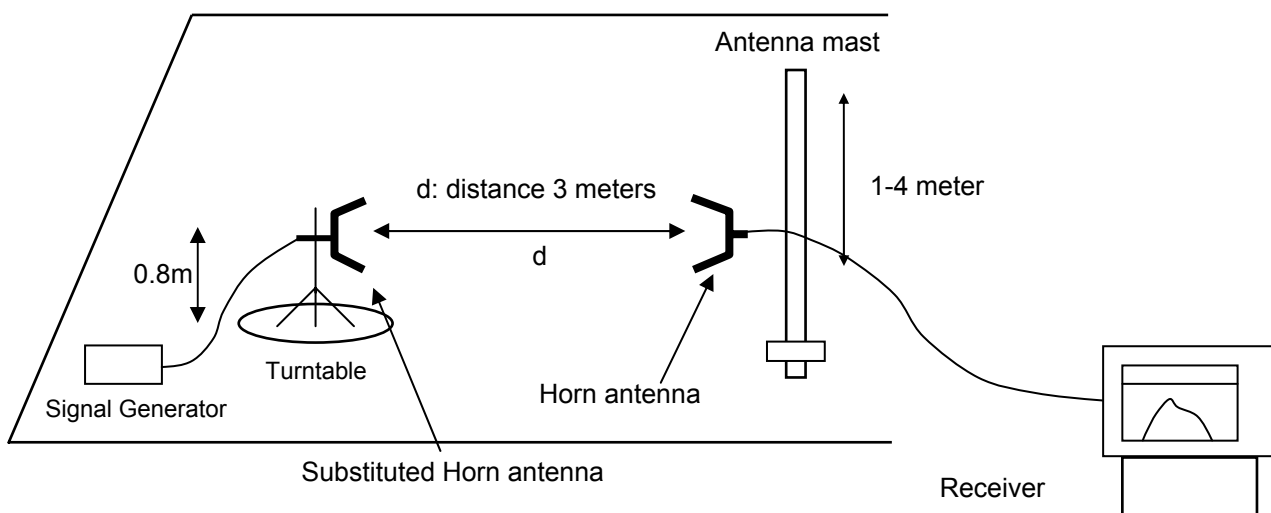
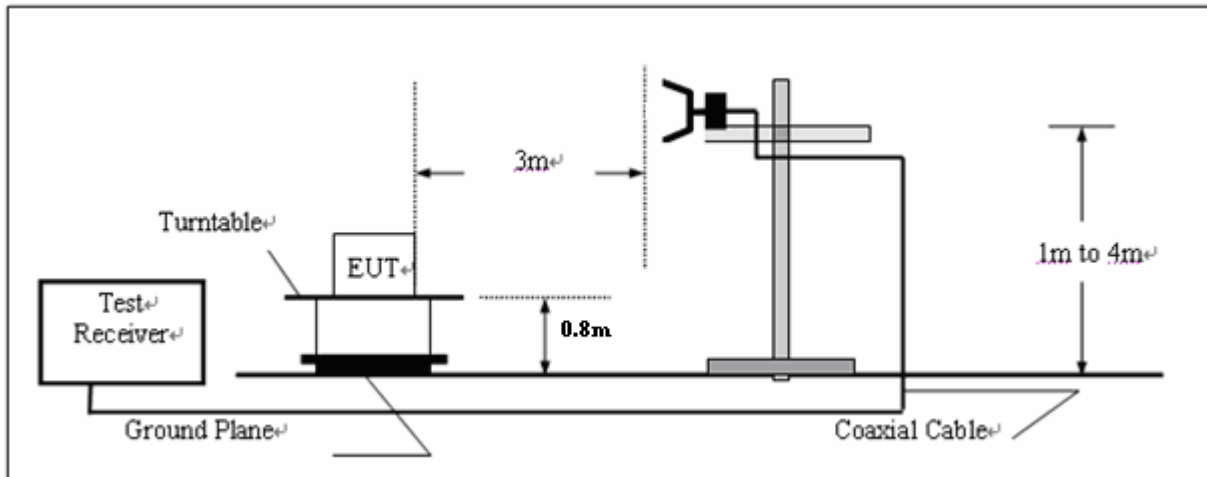
**TEST PROCEDURE**

- 1 On a test site, the EUT shall be placed on a turntable and in the position closest to the normal use as declared by the user.
- 2 The test antenna shall be oriented initially for vertical polarization located 3m from the EUT to correspond to the transmitter.
- 3 The output of the antenna shall be connected to the measuring receiver and either a peak or quasi-peak detector was used for the measurement as in dicated on the report. The detector selection is based on how close the emission level was approaching the limit.
- 4 The transmitter shall be switched on; if possible, without the modulation and the measurement receiver shall be tuned to the frequency of the transmitter under test.
- 5 The test antenna shall be raised and lowered through the specified range of height until the measuring receiver detects a maximum signal level.
- 6 The transmitter shall than be rotated through 360° in the horizontal plane, until the maximum signal level is detected by the measuring receiver.
- 7 The test antenna shall be raised and lowered again through the specified range of height until the measuring receiver detects a maximum signal level.
- 8 The maximum signal level detected by the measuring receiver shall be noted.
- 9 The measurement shall be repeated with the test antenna set to horizontal polarization.
- 10 Replace the antenna with a proper Antenna (substitution antenna).
- 11 The substitution antenna shall be oriented for vertical polarization and, if necessary, the length of the substitution antenna shall be adjusted to correspond to the frequency of transmitting.
- 12 The substitution antenna shall be connected to a calibrated signal generator.
- 13 If necessary, the input attenuator setting of the measuring receiver shall be adjusted in order to increase the sensitivity of the measuring receiver.
- 14 The test antenna shall be raised and lowered through the specified range of the height to ensure that the maximum signal is received.

- 15 The input signal to substitution antenna shall be adjusted to the level that produces a level detected by the measuring receiver, that is equal to the level noted while the transmitter radiated power was measured, corrected for the change of input attenuation setting of the measuring receiver.
- 16 The input level to the substitution antenna shall be recorded as power level in dBm, corrected for any change of input attenuator setting of the measuring receiver.
- 17 The measurement shall be repeated with the test antenna and the substitution antenna oriented for horizontal polarization

TEST RESULTS

The Transmitter Radiated Spurious Emssion was performed to the Rated high power (25Watt) and Rated low power (5Watt) the datum that reported below is the worst case (Rated high power) of the two rated power conditions.

Modulation Type: FM

For FCC:

FCC Part 22.359, 74.462, 80.211 and 90.210 and RSS Gen, RSS 119 Issue 9 (25 kHz bandwidth only):

On any frequency removed from the center of the assigned channel by more than 250 percent at least:

Low: $43 + 10 \log (\text{Pwatts}) = 43 + 10 \log (20.46) = 56.11 \text{ dB}$

High: $43 + 10 \log (\text{Pwatts}) = 43 + 10 \log (22.39) = 58.30 \text{ dB}$

Note: In general, the worse case attenuation requirement shown above was applied.

Calculation: Limit (dBm) =EL-43-10log10 (TP)

Notes: EL is the emission level of the Output Power expressed in dBm,

In this application, the EL is 43.98 dBm.

Limit (dBm) =43.98-43-10log10 (22.39) = -13 dBm

FCC Part 22.359, 74.462, 80.211 and 90.210 and RSS Gen, RSS 119 Issue 9 (25 kHz bandwidth only): On any frequency removed from the center of the authorized bandwidth by a displacement frequency (f d in kHz) of more than 12.5 kHz at least:

Low: $50 + 10 \log (\text{Pwatts}) = 50 + 10 \log (20.46) = 63.11 \text{ dB}$

High: $50 + 10 \log (\text{Pwatts}) = 50 + 10 \log (22.49) = 63.52 \text{ dB}$

Note: In general, the worse case attenuation requirement shown above was applied.

Calculation: Limit (dBm) =EL-50-10log10 (TP)

Notes: EL is the emission level of the Output Power expressed in dBm,

In this application, the EL is 43.98 dBm.

Limit (dBm) =43.98-50-10log10 (22.49) = -20 dBm

For IC:

FCC Part 22.359, 74.462, 80.211 and 90.210 and RSS Gen, RSS 119 Issue 9 (25 kHz bandwidth only):

On any frequency removed from the center of the assigned channel by more than 250 percent at least:

Low: $43 + 10 \log (\text{Pwatts}) = 43 + 10 \log (21.63) = 56.35 \text{ dB}$

High: $43 + 10 \log (\text{Pwatts}) = 43 + 10 \log (22.44) = 56.51 \text{ dB}$

Note: In general, the worse case attenuation requirement shown above was applied.

Calculation: Limit (dBm) =EL-43-10log10 (TP)

Notes: EL is the emission level of the Output Power expressed in dBm,

In this application, the EL is 43.98 dBm.

Limit (dBm) =43.98-43-10log10 (22.44) = -13 dBm

FCC Part 22.359, 74.462, 80.211 and 90.210 and RSS Gen, RSS 119 Issue 9 (25 kHz bandwidth only): On any frequency removed from the center of the authorized bandwidth by a displacement frequency (f d in kHz) of more than 12.5 kHz at least:

Low: $50 + 10 \log (\text{Pwatts}) = 50 + 10 \log (21.58) = 63.58 \text{ dB}$

High: $50 + 10 \log (\text{Pwatts}) = 50 + 10 \log (22.54) = 63.53 \text{ dB}$

Note: In general, the worse case attenuation requirement shown above was applied.

Calculation: Limit (dBm) =EL-50-10log10 (TP)

Notes: EL is the emission level of the Output Power expressed in dBm,

In this application, the EL is 43.98 dBm.

Limit (dBm) =43.98-50-10log10 (22.54) = -20 dBm

Note: 1. In general, the worse case attenuation requirement shown above was applied.

2. The measurement frequency range from 30MHz to 5GHz.

3. *** means that the emission level is too low to be measured or at least 20 dB down than the limit.

For FCC

Modulation Type	Channel Separation	Test Channel	Polar	Maximum Radiated Spurious Emissions Below 1GHz		Maximum Radiated Spurious Emissions Above 1GHz		FCC Limit
				Frequency (MHz)	Datum (dBm)	Frequency (MHz)	Datum (dBm)	
FM	25KHz	Low	H	876.250	-37.29	1752.500	-31.41	-13dBm
			V	876.250	-35.53	2190.625	-33.66	
Test Results				Compliance				

Frequency (MHz)	Reading Level (dBm)	Antenna Polarization	Transd (dB)	Emission level (dBm)	Limit (dBm)	Margin (dB)
876.250	-70.26	H	32.97	-37.29	-13	26.29
1752.500	-36.76	H	5.35	-31.41	-13	18.41
2190.625	-41.63	H	7.38	-34.25	-13	21.25
...	...	H		...		
876.250	-68.50	V	32.97	-35.53	-13	22.53
1752.500	-42.49	V	5.35	-37.14	-13	24.14
2190.625	-41.04	V	7.38	-33.66	-13	20.66
...	...	V		...		

Modulation Type	Channel Separation	Test Channel	Polar	Maximum Radiated Spurious Emissions Below 1GHz		Maximum Radiated Spurious Emissions Above 1GHz		FCC Limit
				Frequency (MHz)	Datum (dBm)	Frequency (MHz)	Datum (dBm)	
FM	25KHz	Middle	H	928.250	-44.75	1856.500	-32.39	-13dBm
			V	928.250	-49.37	1856.500	-34.12	
Test Results				Compliance				

Frequency (MHz)	Reading Level (dBm)	Antenna Polarization	Transd (dB)	Emission level (dBm)	Limit (dBm)	Margin (dB)
928.250	-82.87	H	33.50	-49.37	-13	36.37
1856.500	-38.29	H	5.90	-32.39	-13	19.39
2320.625	-44.21	H	8.24	-35.97	-13	22.97
...	...	H		...		
928.250	-78.25	V	33.50	-44.75	-13	31.75
1856.500	-40.02	V	5.90	-34.12	-13	21.12
2320.625	-45.72	V	8.24	-37.48	-13	24.48
...	...	V		...		

Modulation Type	Channel Separation	Test Channel	Polar	Maximum Radiated Spurious Emissions Below 1GHz		Maximum Radiated Spurious Emissions Above 1GHz		FCC Limit
				Frequency (MHz)	Datum (dBm)	Frequency (MHz)	Datum (dBm)	
FM	25KHz	High	H	979.975	-51.24	1959.950	-25.86	-13dBm
			V	979.975	-46.91	1959.950	-29.29	
Test Results				Compliance				

Frequency (MHz)	Reading Level (dBm)	Antenna Polarization	Transd (dB)	Emission level (dBm)	Limit (dBm)	Margin (dB)
979.975	-85.34	H	34.10	-51.24	-13	38.24
1959.950	-32.54	H	6.68	-25.86	-13	12.86
2449.938	-45.55	H	8.68	-36.87	-13	23.87
...	...	H		...		
979.975	-81.01	V	34.10	-46.91	-13	33.91
1959.950	-35.97	V	6.68	-29.29	-13	16.29
2449.938	-43.12	V	8.68	-34.44	-13	21.44
...	...	V		...		

Modulation Type	Channel Separation	Test Channel	Polar	Maximum Radiated Spurious Emissions Below 1GHz		Maximum Radiated Spurious Emissions Above 1GHz		FCC Limit
				Frequency (MHz)	Datum (dBm)	Frequency (MHz)	Datum (dBm)	
FM	12.5KHz	Low	H	876.250	-37.74	1752.500	-31.89	-20dBm
			V	876.250	-33.36	1752.500	-32.51	
Test Results				Compliance				

Frequency (MHz)	Reading Level (dBm)	Antenna Polarization	Transd (dB)	Emission level (dBm)	Limit (dBm)	Margin (dB)
876.250	-70.71	H	32.97	-37.74	-20	17.74
1752.500	-37.24	H	5.35	-31.89	-20	11.89
2190.625	-40.69	H	7.38	-33.31	-20	13.31
...	...	H		...		
876.250	-66.33	V	32.97	-33.36	-20	13.36
1752.500	-37.86	V	5.35	-32.51	-20	12.51
2190.625	-43.18	V	7.38	-35.80	-20	15.80
...	...	V		...		

Modulation Type	Channel Separation	Test Channel	Polar	Maximum Radiated Spurious Emissions Below 1GHz		Maximum Radiated Spurious Emissions Above 1GHz		FCC Limit
				Frequency (MHz)	Datum (dBm)	Frequency (MHz)	Datum (dBm)	
FM	12.5KHz	Middle	H	928.250	-47.76	1856.500	-34.11	-20dBm
			V	928.250	-42.18	1856.500	-33.43	
Test Results				Compliance				

Frequency (MHz)	Reading Level (dBm)	Antenna Polarization	Transd (dB)	Emission level (dBm)	Limit (dBm)	Margin (dB)
928.250	-81.26	H	33.50	-47.76	-20	27.76
1856.500	-40.01	H	5.90	-34.11	-20	14.11
2320.625	-46.75	H	8.24	-38.51	-20	18.51
...	...	H		...		
928.250	-75.68	V	33.50	-42.18	-20	22.18
1856.500	-39.33	V	5.90	-33.43	-20	13.43
2320.625	-46.36	V	8.24	-38.12	-20	18.12
...	...	V		...		

Modulation Type	Channel Separation	Test Channel	Polar	Maximum Radiated Spurious Emissions Below 1GHz		Maximum Radiated Spurious Emissions Above 1GHz		FCC Limit
				Frequency (MHz)	Datum (dBm)	Frequency (MHz)	Datum (dBm)	
FM	12.5KHz	High	H	979.975	-46.82	1959.950	-25.12	-20dBm
			V	979.975	-49.74	1959.950	-29.88	
Test Results				Compliance				

Frequency (MHz)	Reading Level (dBm)	Antenna Polarization	Transd (dB)	Emission level (dBm)	Limit (dBm)	Margin (dB)
979.975	-80.92	H	34.10	-46.82	-20	26.82
1959.950	-31.80	H	6.68	-25.12	-20	5.12
2449.938	-43.69	H	8.68	-35.01	-20	15.01
...	...	H		...		
979.975	-83.84	V	34.10	-49.74	-20	29.74
1959.950	-36.56	V	6.68	-29.88	-20	9.88
2449.938	-44.95	V	8.68	-36.27	-20	16.27
...	...	V		...		

For IC

Modulation Type	Channel Sparation	Test Channel	Polar	Maximum Radiated Spurious Emissions Below 1GHz		Maximum Radiated Spurious Emissions Above 1GHz		FCC Limit
				Frequency (MHz)	Datum (dBm)	Frequency (MHz)	Datum (dBm)	
FM	25KHz	Low	H	900.250	-41.98	1800.500	-29.52	-13dBm
			V	900.250	-40.65	1800.500	-32.14	
Test Results				Compliance				

Frequency (MHz)	Reading Level (dBm)	Antenna Polarization	Transd (dB)	Emission level (dBm)	Limit (dBm)	Margin (dB)
900.250	-75.18	H	33.20	-41.98	-13	28.98
1800.500	-35.15	H	5.63	-29.52	-13	16.52
2250.625	-41.98	H	5.87	-36.11	-13	23.11
...	...	H		...		
900.250	-73.85	V	33.20	-40.65	-13	27.65
1800.500	-37.77	V	5.63	-32.14	-13	19.14
2250.625	-41.97	V	5.87	-36.10	-13	23.10
...	...	V		...		

Modulation Type	Channel Sparation	Test Channel	Polar	Maximum Radiated Spurious Emissions Below 1GHz		Maximum Radiated Spurious Emissions Above 1GHz		FCC Limit
				Frequency (MHz)	Datum (dBm)	Frequency (MHz)	Datum (dBm)	
FM	25KHz	Middle	H	920.250	-47.94	1840.500	-33.17	-13dBm
			V	920.250	-41.04	1840.500	-34.77	
Test Results				Compliance				

Frequency (MHz)	Reading Level (dBm)	Antenna Polarization	Transd (dB)	Emission level (dBm)	Limit (dBm)	Margin (dB)
920.250	-81.84	H	33.90	-47.94	-13	34.94
1840.500	-38.98	H	5.81	-33.17	-13	20.17
2300.625	-44.74	H	8.15	-36.59	-13	23.59
...	...	H		...		
920.250	-74.94	V	33.90	-41.04	-13	28.04
1840.500	-40.58	V	5.81	-34.77	-13	21.77
2300.625	-46.41	V	8.15	-38.26	-13	25.26
...	...	V		...		

Modulation Type	Channel Sparation	Test Channel	Polar	Maximum Radiated Spurious Emissions Below 1GHz		Maximum Radiated Spurious Emissions Above 1GHz		FCC Limit
				Frequency (MHz)	Datum (dBm)	Frequency (MHz)	Datum (dBm)	
FM	25KHz	High	H	939.975	-46.91	1879.950	-31.15	-13dBm
			V	939.975	-46.54	1879.950	-30.88	
Test Results				Compliance				

Frequency (MHz)	Reading Level (dBm)	Antenna Polarization	Transd (dB)	Emission level (dBm)	Limit (dBm)	Margin (dB)
939.975	-81.13	H	34.22	-46.91	-13	33.91
1879.950	-37.40	H	6.25	-31.15	-13	18.15
2349.938	-49.48	H	8.21	-41.27	-13	28.27
...	...	H		...		
939.975	-80.76	V	34.22	-46.54	-13	33.54
1879.950	-37.13	V	6.25	-30.88	-13	17.88
2349.938	-43.62	V	8.21	-35.41	-13	22.41
...	...	V		...		

Modulation Type	Channel Sparation	Test Channel	Polar	Maximum Radiated Spurious Emissions Below 1GHz		Maximum Radiated Spurious Emissions Above1GHz		FCC Limit
				Frequency (MHz)	Datum (dBm)	Frequency (MHz)	Datum (dBm)	
FM	12.5KHz	Low	H	900.250	-43.86	1800.500	-30.68	-20dBm
			V	900.250	-40.37	1800.500	-31.29	
Test Results				Compliance				

Frequency (MHz)	Reading Level (dBm)	Antenna Polarization	Transd (dB)	Emission level (dBm)	Limit (dBm)	Margin (dB)
900.250	-77.06	H	33.20	-43.86	-20	23.86
1800.500	-36.31	H	5.63	-30.68	-20	10.68
2250.625	-42.59	H	5.87	-36.72	-20	16.72
...	...	H		...		
900.250	-73.57	V	33.20	-40.37	-20	20.37
1800.500	-36.92	V	5.63	-31.29	-20	11.29
2250.625	-42.86	V	5.87	-36.99	-20	16.99
...	...	V		...		

Modulation Type	Channel Sparation	Test Channel	Polar	Maximum Radiated Spurious Emissions Below 1GHz		Maximum Radiated Spurious Emissions Above1GHz		FCC Limit
				Frequency (MHz)	Datum (dBm)	Frequency (MHz)	Datum (dBm)	
FM	12.5KHz	Middle	H	920.250	-48.86	1840.500	-32.46	-20dBm
			V	920.250	-41.83	1840.500	-33.40	
Test Results				Compliance				

Frequency (MHz)	Reading Level (dBm)	Antenna Polarization	Transd (dB)	Emission level (dBm)	Limit (dBm)	Margin (dB)
920.250	-82.76	H	33.90	-48.86	-20	28.86
1840.500	-38.27	H	5.81	-32.46	-20	12.46
2300.625	-45.60	H	8.15	-37.45	-20	17.45
...	...	H		...		
920.250	-75.73	V	33.90	-41.83	-20	21.83
1840.500	-39.21	V	5.81	-33.40	-20	13.40
2300.625	-43.75	V	8.15	-35.60	-20	15.60
...	...	V		...		

Modulation Type	Channel Sparation	Test Channel	Polar	Maximum Radiated Spurious Emissions Below 1GHz		Maximum Radiated Spurious Emissions Above1GHz		FCC Limit
				Frequency (MHz)	Datum (dBm)	Frequency (MHz)	Datum (dBm)	
FM	12.5KHz	High	H	939.975	-48.10	1879.950	-32.00	-20dBm
			V	939.975	-45.52	1879.950	-30.76	
Test Results				Compliance				

Frequency (MHz)	Reading Level (dBm)	Antenna Polarization	Transd (dB)	Emission level (dBm)	Limit (dBm)	Margin (dB)
939.975	-82.32	H	34.22	-48.10	-20	28.10
1879.950	-38.25	H	6.25	-32.00	-20	12.00
2349.938	-48.73	H	8.21	-40.52	-20	20.52
...	...	H		...		
939.975	-79.74	V	34.22	-45.52	-20	25.52
1879.950	-37.01	V	6.25	-30.76	-20	10.76
2349.938	-43.61	V	8.21	-35.40	-20	15.40
...	...	V		...		

4.4. Spurious Emission on Antenna Port

TEST APPLICABLE

The same as Section 4.3

TEST PROCEDURE

The RF output of the EUT was connected to a spectrum analyzer through appropriate attenuation. The resolution bandwidth of the spectrum analyzer was set to 100 kHz. Sufficient scans were taken to show any out of band emission up to 10th. Harmonic for the lower and the highest frequency range. RBW 100 kHz, VBW 300 kHz,

The audio input was set to 0 to get the unmodulated carrier, the resulting picture is print out for each channel separation.

TEST CONFIGURATION

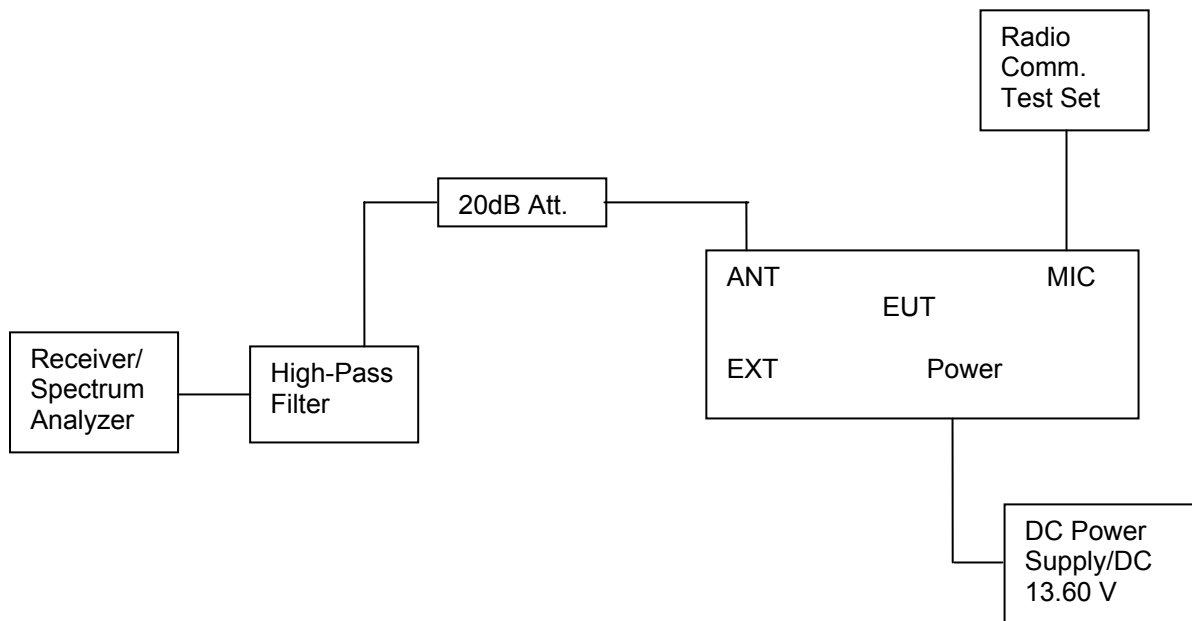

TEST RESULTS

Modulation Type: FM

For FCC:

FCC Part 22.359, 74.462, 80.211 and 90.210 and RSS Gen, RSS 119 Issue 9 (25 kHz bandwidth only):

On any frequency removed from the center of the assigned channel by more than 250 percent at least:

Low: $43 + 10 \log (P_{\text{watts}}) = 43 + 10 \log (20.46) = 56.11 \text{ dB}$

High: $43 + 10 \log (P_{\text{watts}}) = 43 + 10 \log (22.39) = 58.30 \text{ dB}$

Note: In general, the worse case attenuation requirement shown above was applied.

Calculation: Limit (dBm) = EL - 43 - 10log10 (TP)

Notes: EL is the emission level of the Output Power expressed in dBm,

In this application, the EL is 43.98 dBm.

Limit (dBm) = $43.98 - 43 - 10 \log_{10} (22.39) = -13 \text{ dBm}$

FCC Part 22.359, 74.462, 80.211 and 90.210 and RSS Gen, RSS 119 Issue 9 (25 kHz bandwidth only): On any frequency removed from the center of the authorized bandwidth by a displacement frequency (f d in kHz) of more than 12.5 kHz at least:

Low: $50 + 10 \log (P_{\text{watts}}) = 50 + 10 \log (20.46) = 63.11 \text{ dB}$

High: $50 + 10 \log (P_{\text{watts}}) = 50 + 10 \log (22.49) = 63.52 \text{ dB}$

Note: In general, the worse case attenuation requirement shown above was applied.

Calculation: Limit (dBm) = EL - 50 - 10log10 (TP)

Notes: EL is the emission level of the Output Power expressed in dBm,

In this application, the EL is 43.98 dBm.

Limit (dBm) = $43.98 - 50 - 10 \log_{10} (22.49) = -20 \text{ dBm}$

For IC:

FCC Part 22.359, 74.462, 80.211 and 90.210 and RSS Gen, RSS 119 Issue 9 (25 kHz bandwidth only):
On any frequency removed from the center of the assigned channel by more than 250 percent at least:

Low: $43 + 10 \log(\text{Pwatts}) = 43 + 10 \log(21.63) = 56.35 \text{ dB}$

High: $43 + 10 \log(\text{Pwatts}) = 43 + 10 \log(22.44) = 56.51 \text{ dB}$

Note: In general, the worse case attenuation requirement shown above was applied.

Calculation: Limit (dBm) = EL - 43 - 10log10 (TP)

Notes: EL is the emission level of the Output Power expressed in dBm,

In this application, the EL is 43.98 dBm.

Limit (dBm) = $43.98 - 43 - 10 \log_{10}(22.44) = -13 \text{ dBm}$

FCC Part 22.359, 74.462, 80.211 and 90.210 and RSS Gen, RSS 119 Issue 9 (25 kHz bandwidth only): On any frequency removed from the center of the authorized bandwidth by a displacement frequency (f d in kHz) of more than 12.5 kHz at least:

Low: $50 + 10 \log(\text{Pwatts}) = 50 + 10 \log(21.58) = 63.58 \text{ dB}$

High: $50 + 10 \log(\text{Pwatts}) = 50 + 10 \log(22.54) = 63.53 \text{ dB}$

Note: In general, the worse case attenuation requirement shown above was applied.

Calculation: Limit (dBm) = EL - 50 - 10log10 (TP)

Notes: EL is the emission level of the Output Power expressed in dBm,

In this application, the EL is 43.98 dBm.

Limit (dBm) = $43.98 - 50 - 10 \log_{10}(22.54) = -20 \text{ dBm}$

Note: 1. In general, the worse case attenuation requirement shown above was applied.

2. The measurement frequency range from 30MHz to 5 GHz.

For FCC**For Rated High Power (25Watt)**

Modulation Type	Channel Separation	Test Channel	Test Frequency (MHz)	Maximum Conducted Spurious Emissions Below 1GHz		Maximum Conducted Spurious Emissions Above 1GHz	
				Frequency (MHz)	Datum (dBm)	Frequency (MHz)	Datum (dBm)
FM	25KHz	Low	438.1250	876.13	-26.21	3757.52	-26.50
		Middle	464.1250	929.78	-26.60	2803.61	-26.64
		High	489.9875	906.89	-27.13	4959.92	-26.43
	12.5KHz	Low	438.1250	980.56	-25.46	3749.50	-26.94
		Middle	464.1250	920.30	-26.94	4927.86	-26.38
		High	489.9875	877.54	-26.31	2947.90	-26.44
Limit		-13dBm for 25KHz Channel Separation					
		-20dBm for 12.5KHz Channel Separation					
Test Results		Compliance					

For Rated Low Power (5Watt)

Modulation Type	Channel Separation	Test Channel	Test Frequency (MHz)	Maximum Conducted Spurious Emissions Below 1GHz		Maximum Conducted Spurious Emissions Above 1GHz	
				Frequency (MHz)	Datum (dBm)	Frequency (MHz)	Datum (dBm)
FM	25KHz	Low	438.1250	912.53	-27.22	4438.88	-27.31
		Middle	464.1250	930.02	-27.38	2923.85	-26.93
		High	489.9875	877.54	-26.30	2915.83	-27.34
	12.5KHz	Low	438.1250	947.37	-27.25	1649.30	-26.75
		Middle	464.1250	979.79	-26.95	13.92.79	-27.24
		High	489.9875	876.13	-26.73	4575.15	-27.04
Limit		-13dBm for 25KHz Channel Separation					
		-20dBm for 12.5KHz Channel Separation					
Test Results		Compliance					

For IC**For Rated High Power (25Watt)**

Modulation Type	Channel Separation	Test Channel	Test Frequency (MHz)	Maximum Conducted Spurious Emissions Below 1GHz		Maximum Conducted Spurious Emissions Above 1GHz	
				Frequency (MHz)	Datum (dBm)	Frequency (MHz)	Datum (dBm)
FM	25KHz	Low	450.1250	674.61	-18.66	2939.88	-26.53
		Middle	460.1250	959.27	-26.27	1367.75	-26.99
		High	469.9875	966.33	-26.99	4519.04	-26.90
	12.5KHz	Low	450.1250	674.60	-25.33	2955.91	-26.85
		Middle	460.1250	998.93	-26.92	1376.75	-26.54
		High	469.9875	907.41	-27.13	4519.04	-26.46
Limit		-13dBm for 25KHz Channel Separation					
		-20dBm for 12.5KHz Channel Separation					
Test Results		Compliance					

For Rated Low Power (5Watt)

Modulation Type	Channel Separation	Test Channel	Test Frequency (MHz)	Maximum Conducted Spurious Emissions Below 1GHz		Maximum Conducted Spurious Emissions Above 1GHz	
				Frequency (MHz)	Datum (dBm)	Frequency (MHz)	Datum (dBm)
FM	25KHz	Low	450.1250	953.35	-26.55	4543.09	-27.33
		Middle	460.1250	966.95	-27.41	2995.99	-27.02
		High	469.9875	970.84	-27.22	2899.80	-27.07
	12.5KHz	Low	450.1250	986.39	-26.93	2963.93	-26.64
		Middle	460.1250	792.00	-25.88	3452.91	-27.05
		High	469.9875	968.90	-26.78	2386.77	-26.86
Limit		-13dBm for 25KHz Channel Separation					
		-20dBm for 12.5KHz Channel Separation					
Test Results		Compliance					

Plots of Spurious Emission on Antenna Port Measurement**For FCC**

For Rated High Power (25Watt)

Modulation Type	Channel Separation	Test Channel	Test Frequency (MHz)	Maximum Conducted Spurious Emissions Below 1GHz		Maximum Conducted Spurious Emissions Above 1GHz		FCC Limit
				Frequency (MHz)	Datum (dBm)	Frequency (MHz)	Datum (dBm)	
FM	25KHz	Low	438.1250	876.13	-26.21	3757.52	-26.50	-13dBm
Test Results				Compliance				

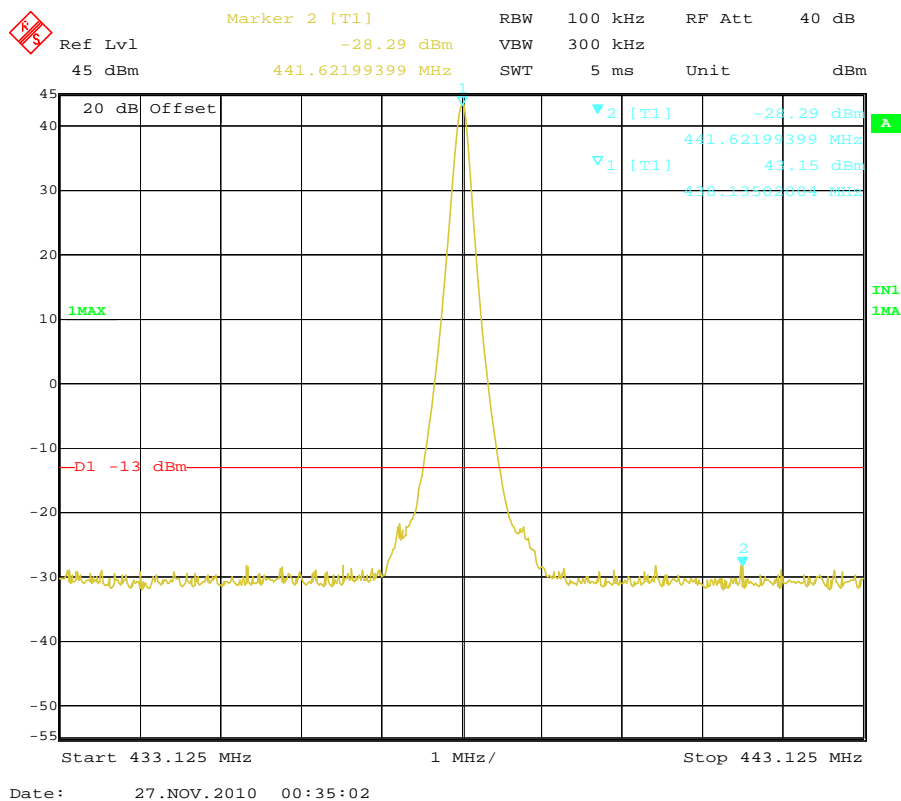
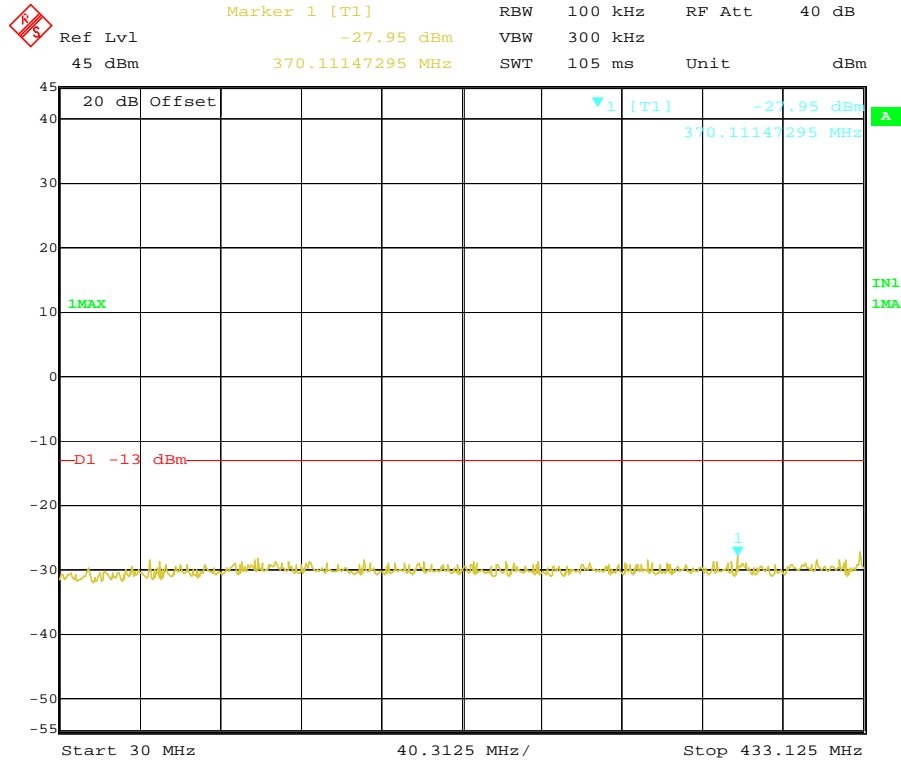

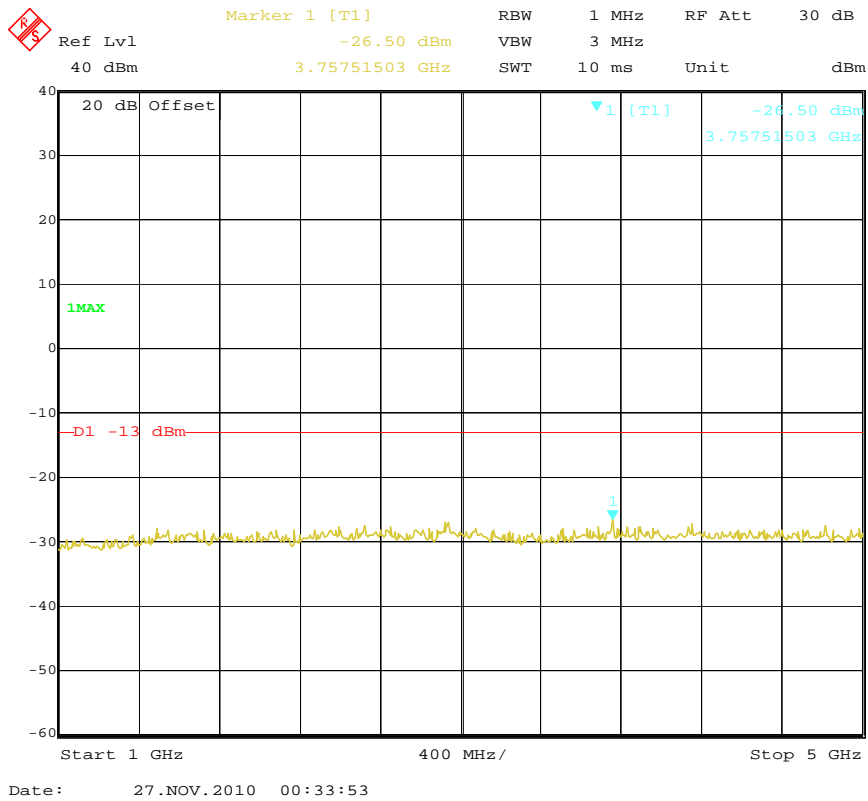
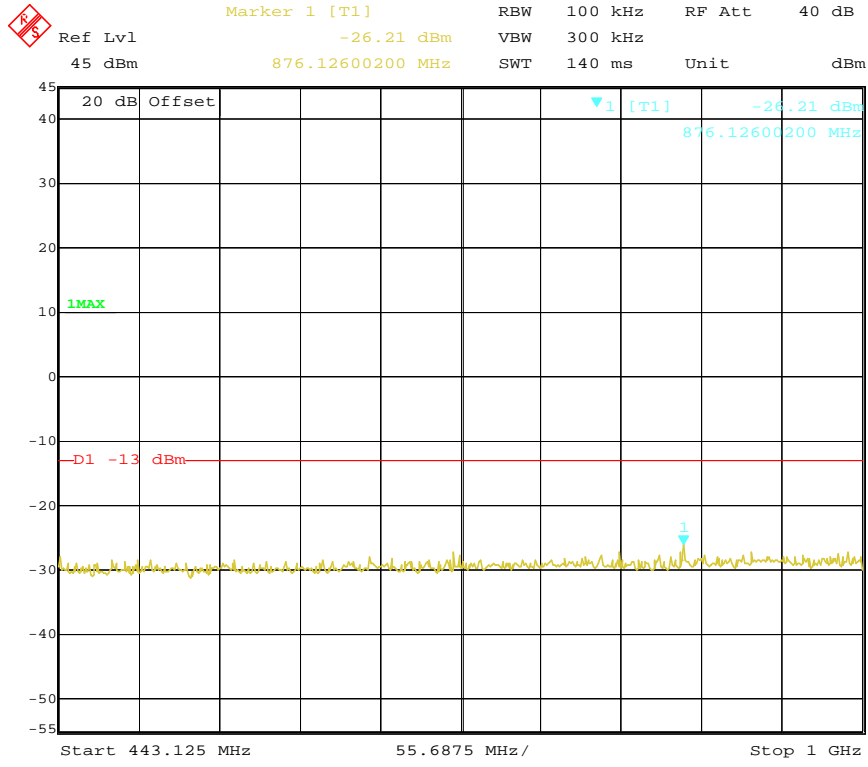

Modulation Type	Channel Separation	Test Channel	Test Frequency (MHz)	Maximum Conducted Spurious Emissions Below 1GHz		Maximum Conducted Spurious Emissions Above 1GHz		FCC Limit
				Frequency (MHz)	Datum (dBm)	Frequency (MHz)	Datum (dBm)	
FM	25KHz	Middle	464.1250	929.78	-26.60	2803.61	-26.64	-13dBm
Test Results				Compliance				

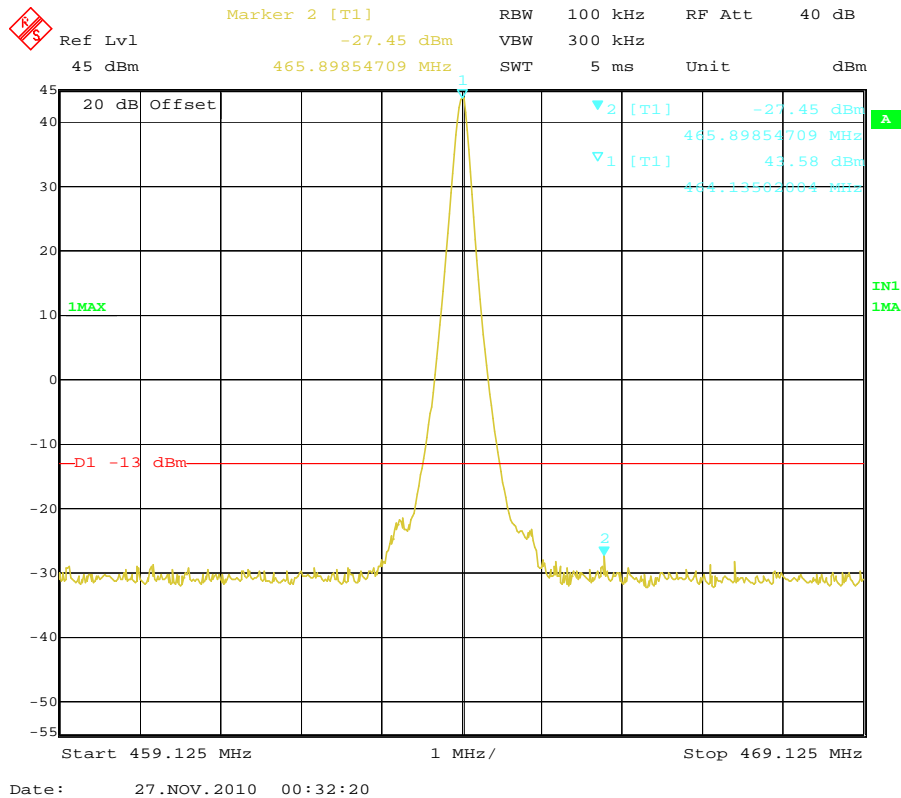
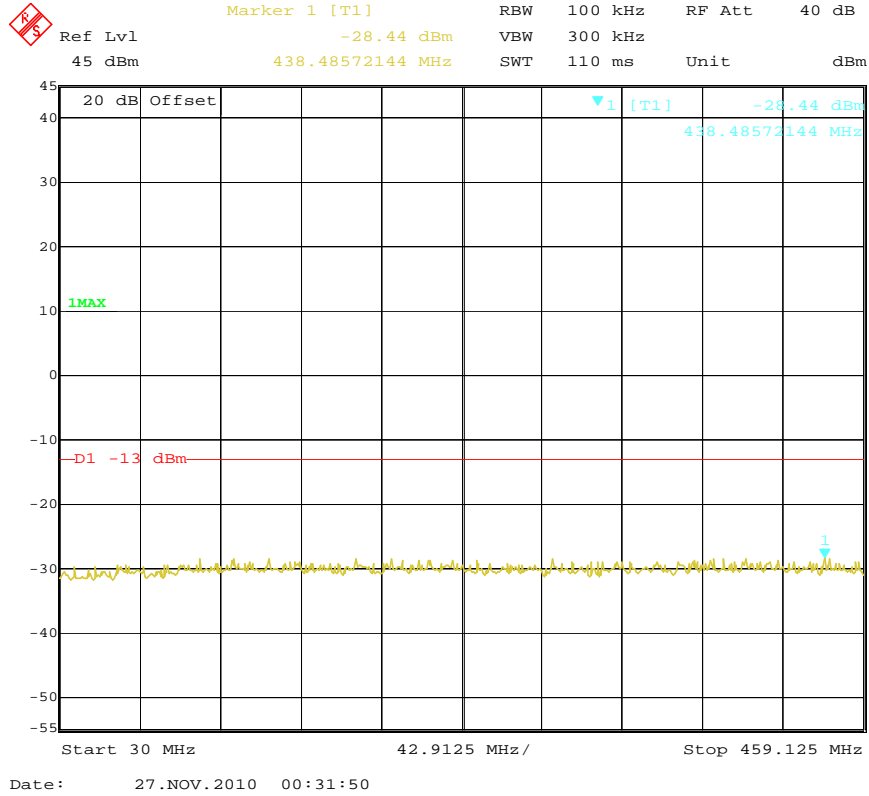

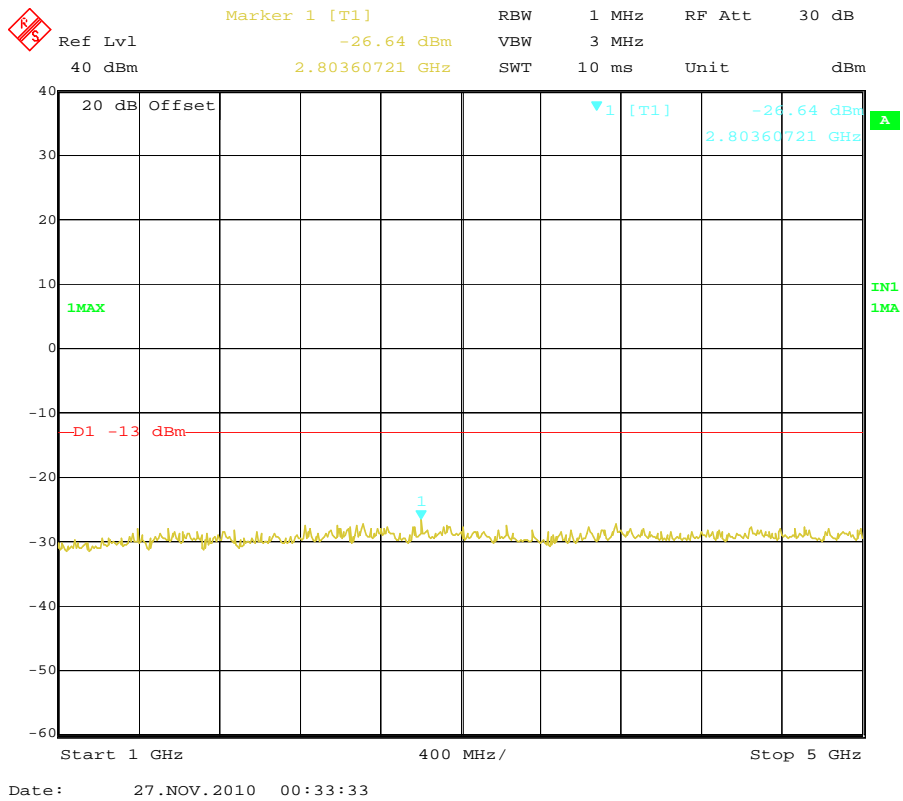
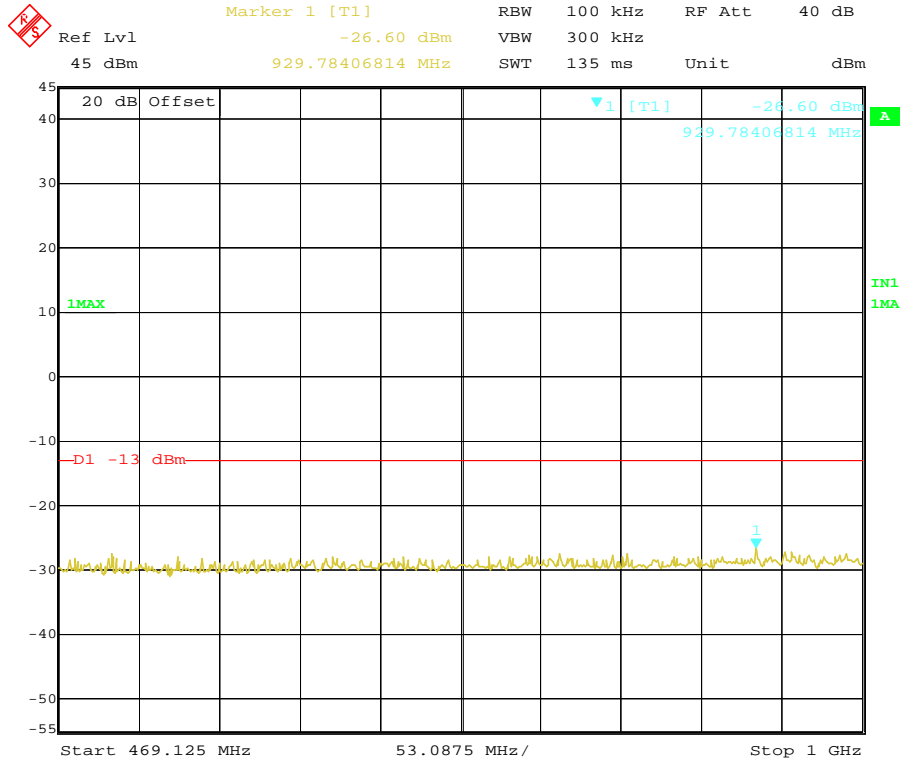

Modulation Type	Channel SpARATION	Test Channel	Test Frequency (MHz)	Maximum Conducted Spurious Emissions Below 1GHz		Maximum Conducted Spurious Emissions Above 1GHz		FCC Limit
				Frequency (MHz)	Datum (dBm)	Frequency (MHz)	Datum (dBm)	
FM	25KHz	High	489.9875	906.89	-27.13	4959.92	-26.43	-13dBm
Test Results				Compliance				

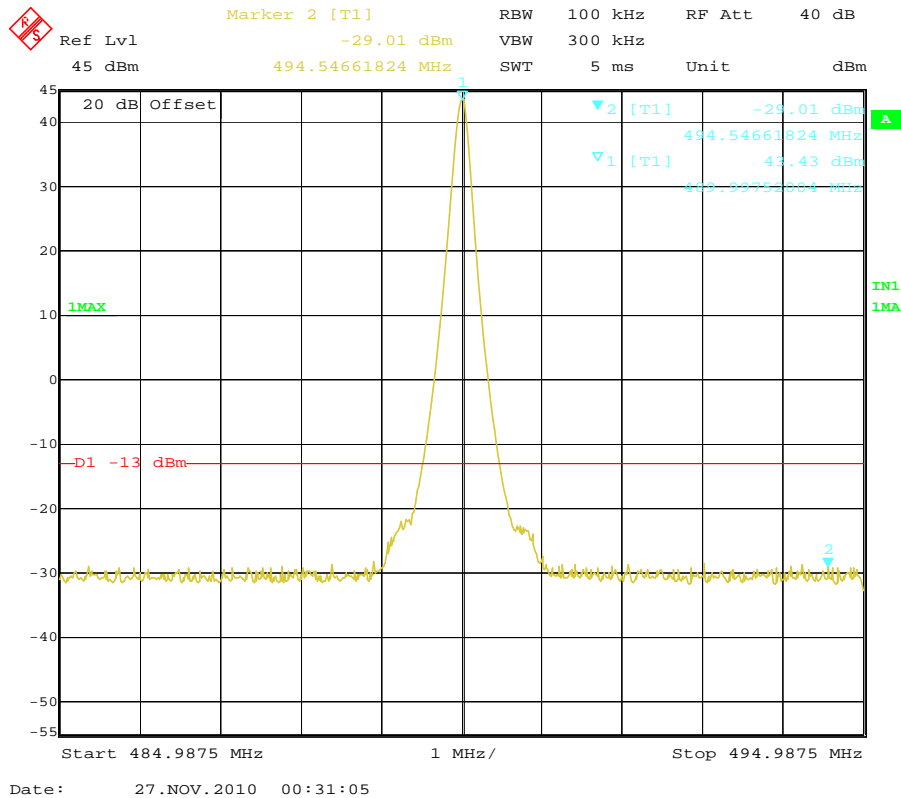
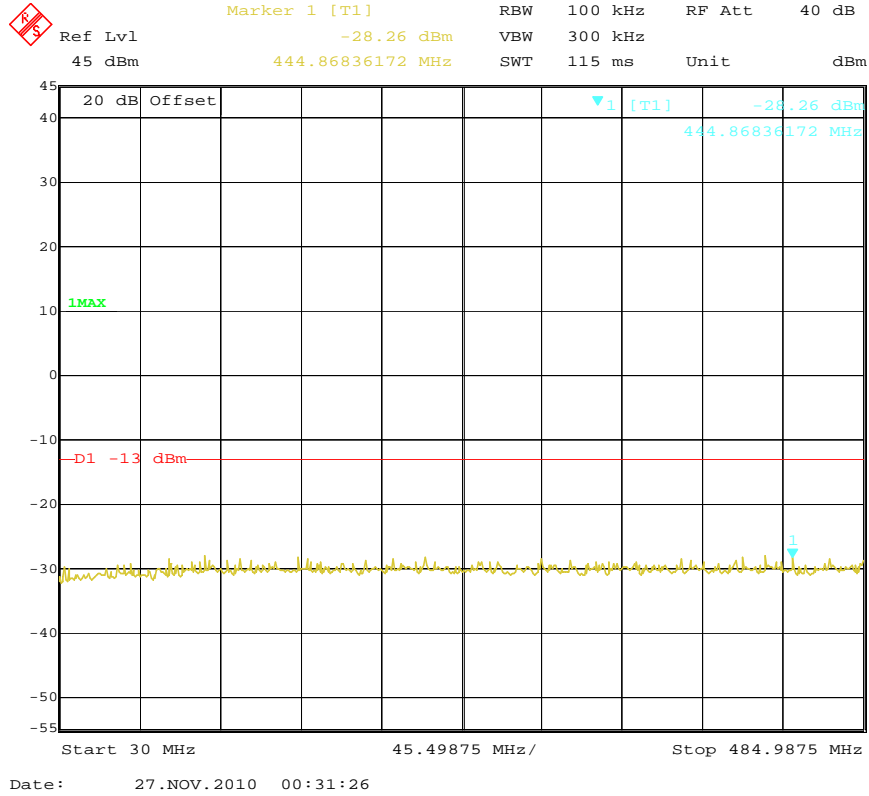

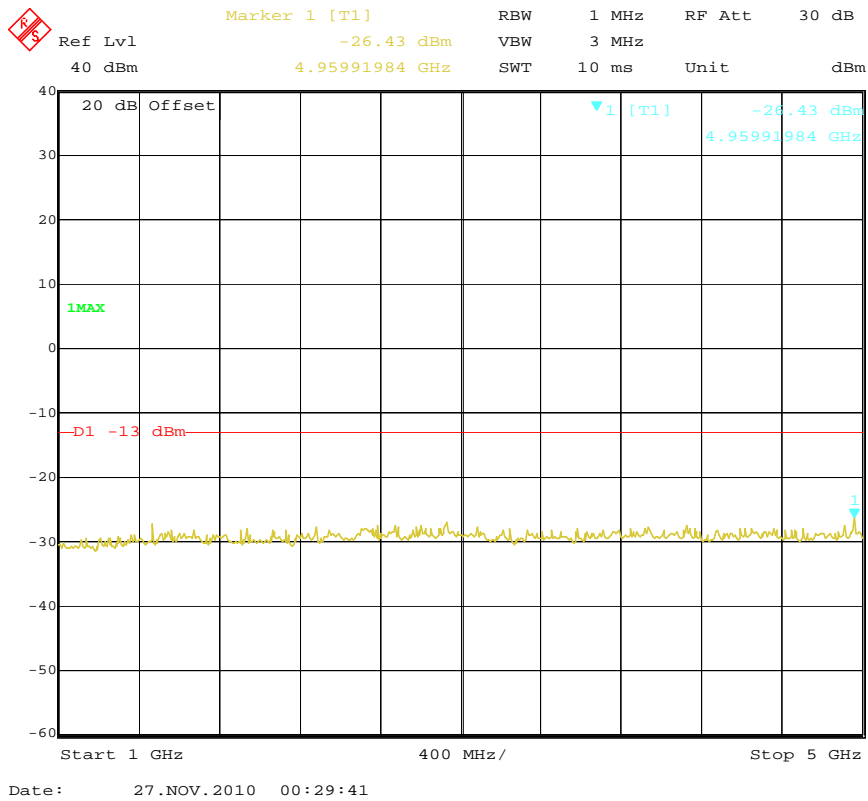
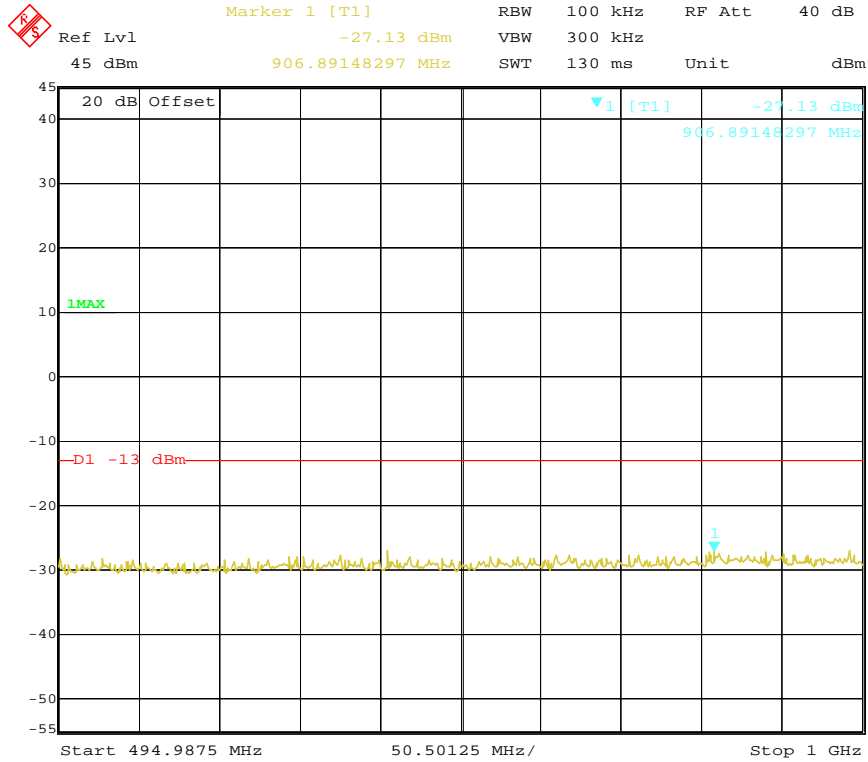

Modulation Type	Channel SpARATION	Test Channel	Test Frequency (MHz)	Maximum Conducted Spurious Emissions Below 1GHz		Maximum Conducted Spurious Emissions Above 1GHz		FCC Limit
				Frequency (MHz)	Datum (dBm)	Frequency (MHz)	Datum (dBm)	
FM	12.5KHz	Low	438.1250	876.13	-26.73	4575.15	-27.04	-20dBm
Test Results				Compliance				

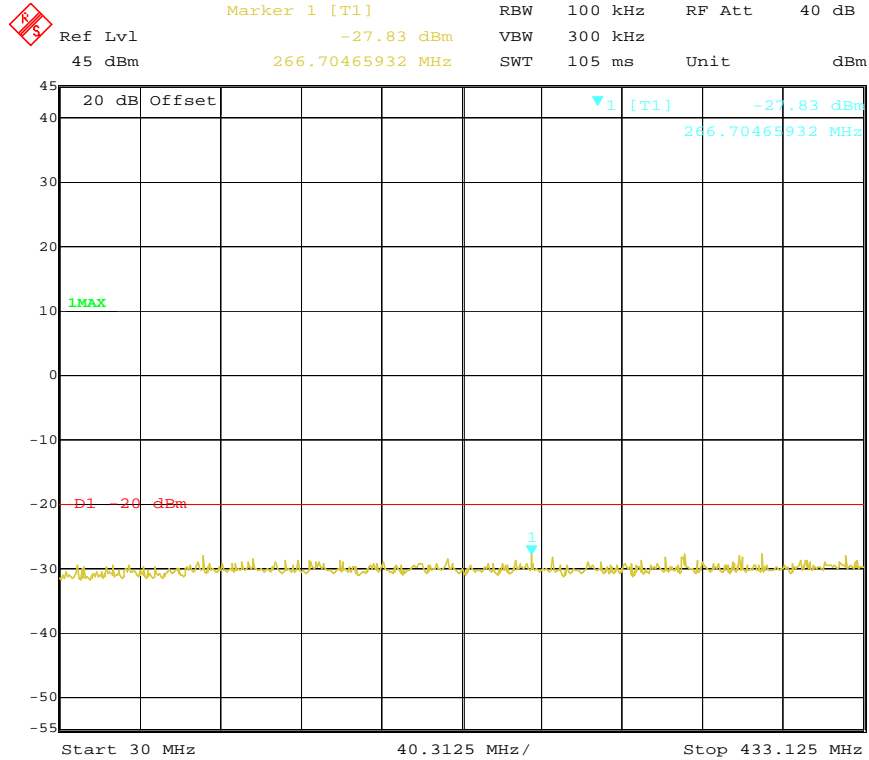

Date: 27.NOV.2010 00:27:14

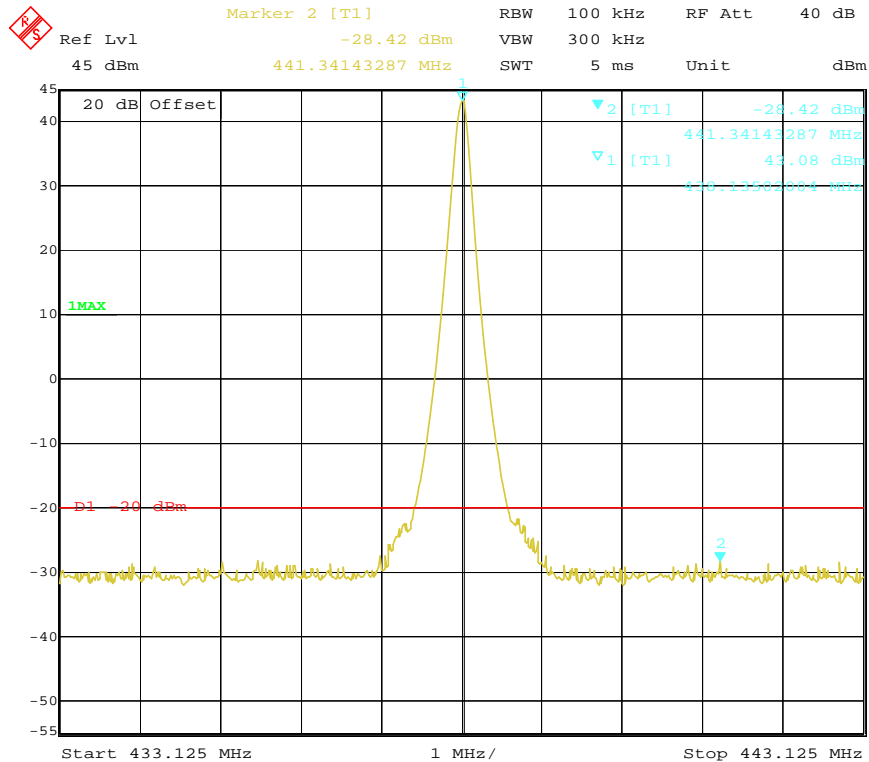

Date: 27.NOV.2010 00:28:01

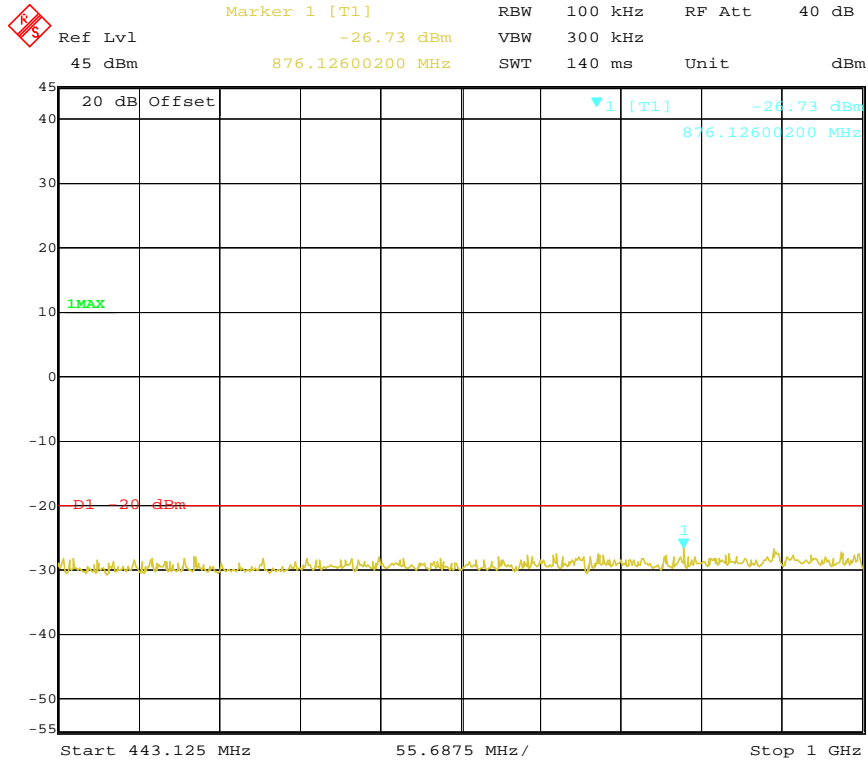

Date: 27.NOV.2010 00:28:55

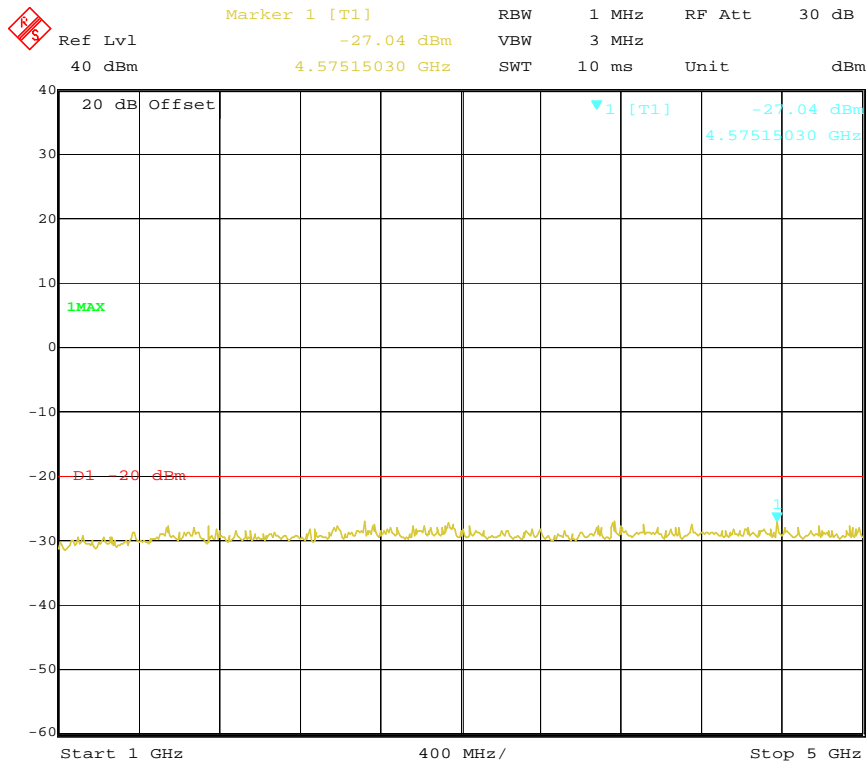

Date: 27.NOV.2010 00:29:23

Modulation Type	Channel SpARATION	Test Channel	Test Frequency (MHz)	Maximum Conducted Spurious Emissions Below 1GHz		Maximum Conducted Spurious Emissions Above 1GHz		FCC Limit
				Frequency (MHz)	Datum (dBm)	Frequency (MHz)	Datum (dBm)	
FM	12.5KHz	Middle	464.1250	979.79	-26.95	13.92.79	-27.24	-20dBm
Test Results				Compliance				

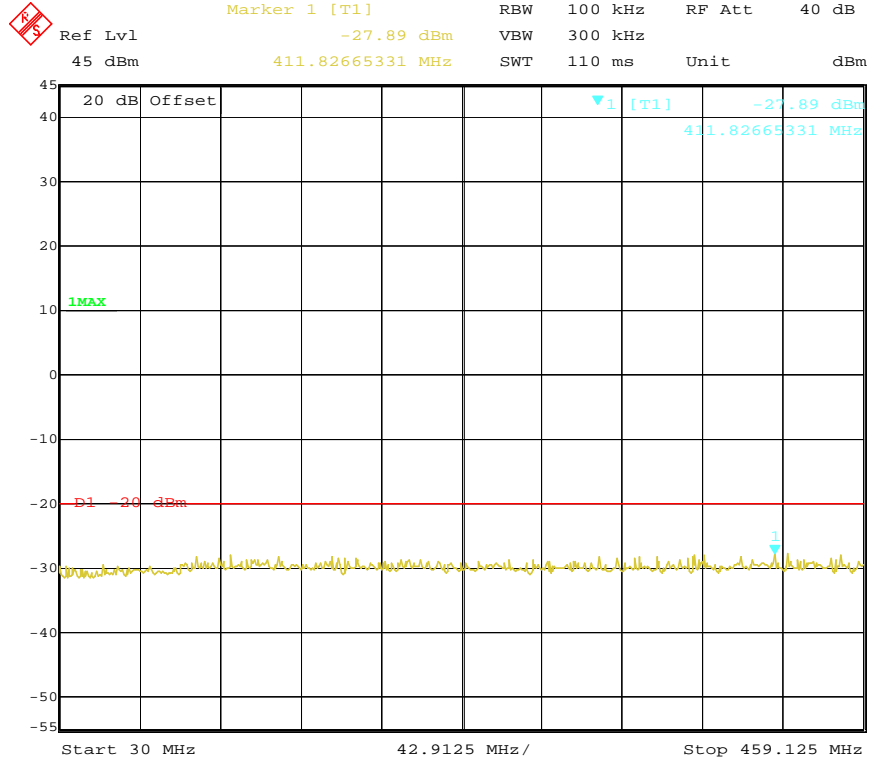

Date: 27.NOV.2010 00:26:47

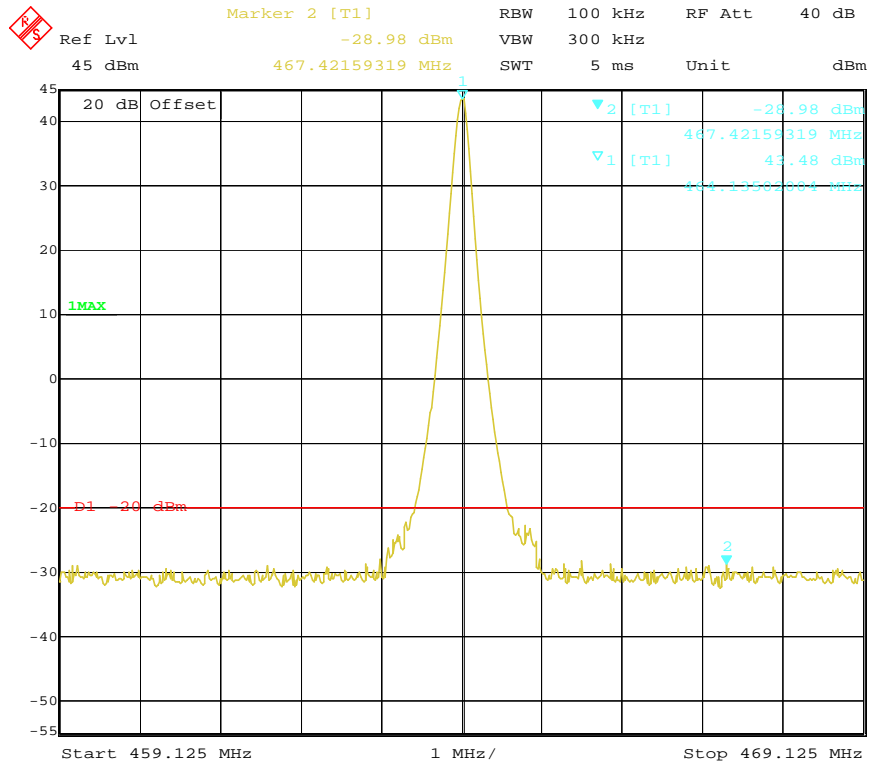

Date: 27.NOV.2010 00:26:16

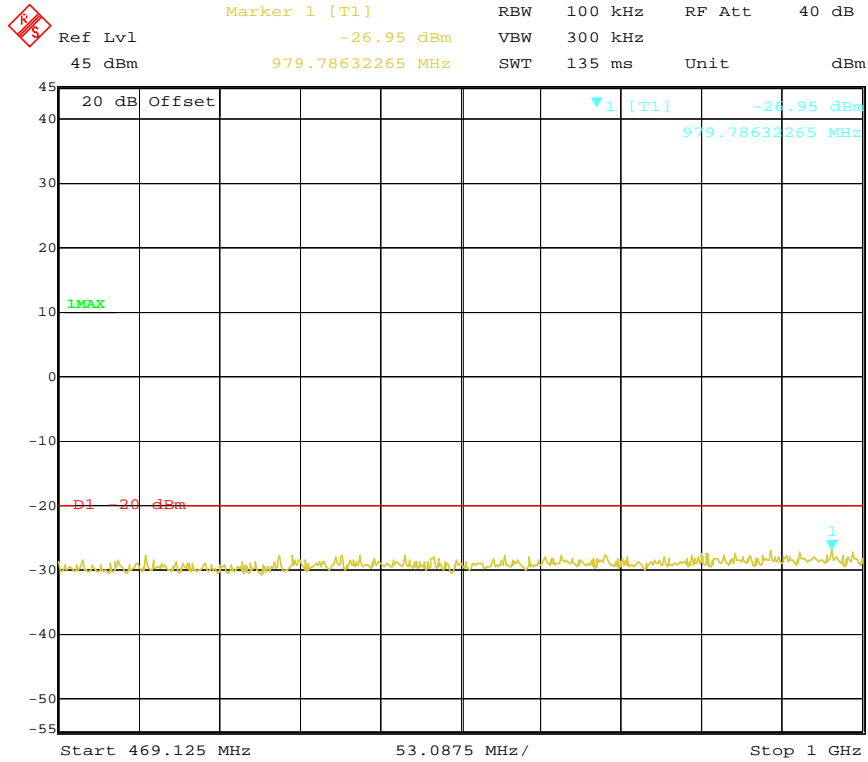

Date: 27.NOV.2010 00:24:53

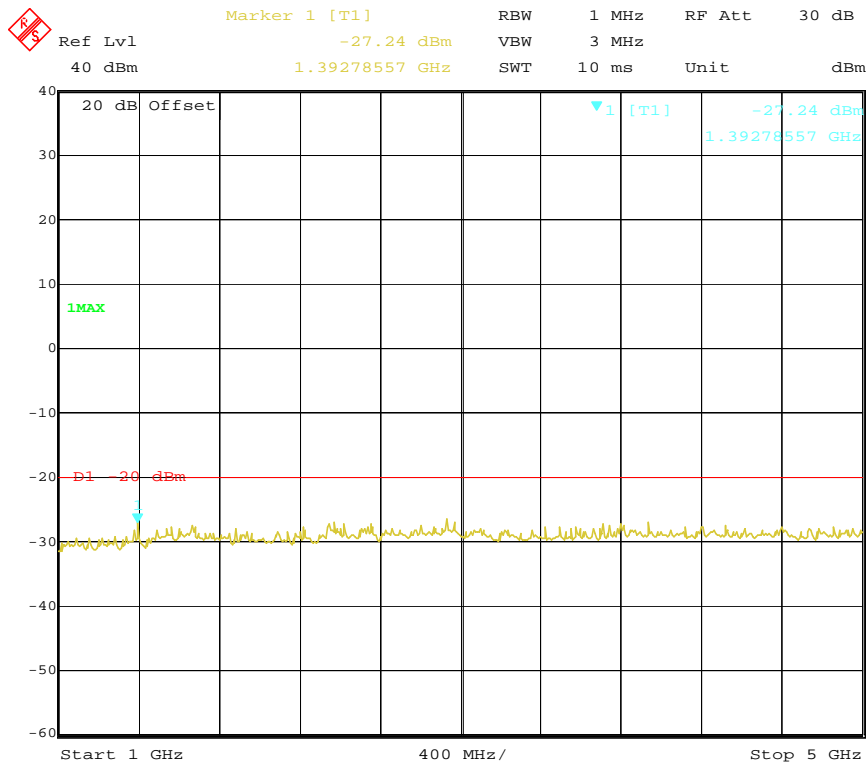

Date: 27.NOV.2010 00:24:14

Modulation Type	Channel Sparation	Test Channel	Test Frequency (MHz)	Maximum Conducted Spurious Emissions Below 1GHz		Maximum Conducted Spurious Emissions Above 1GHz		FCC Limit
				Frequency (MHz)	Datum (dBm)	Frequency (MHz)	Datum (dBm)	
FM	12.5KHz	High	489.9875	947.37	-27.25	1649.30	-26.75	-20dBm
Test Results				Compliance				

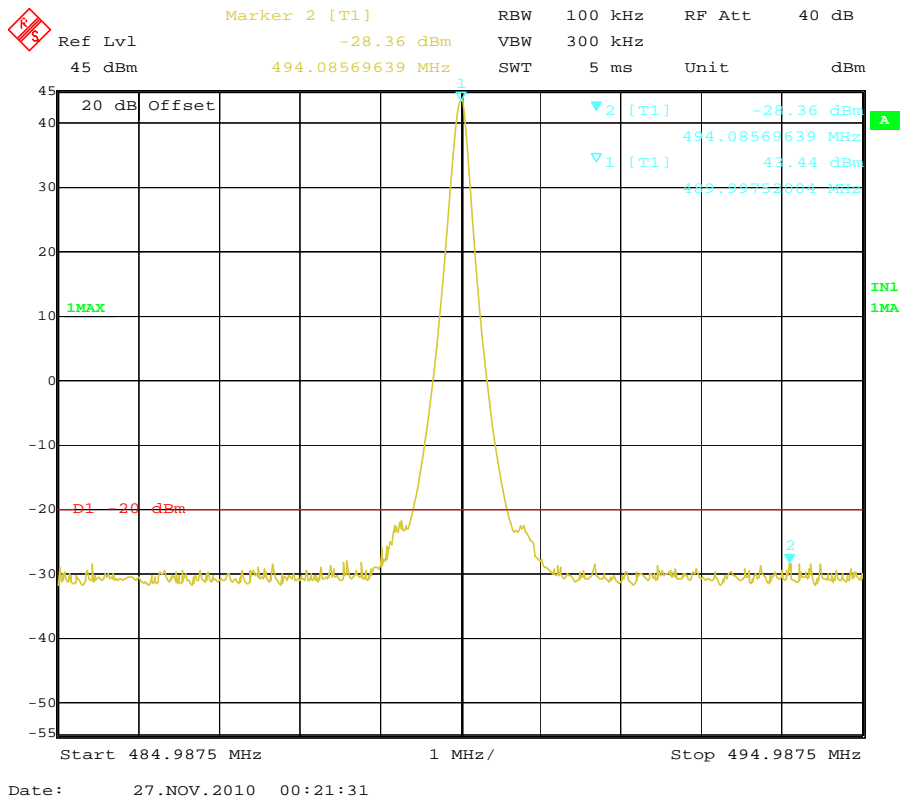
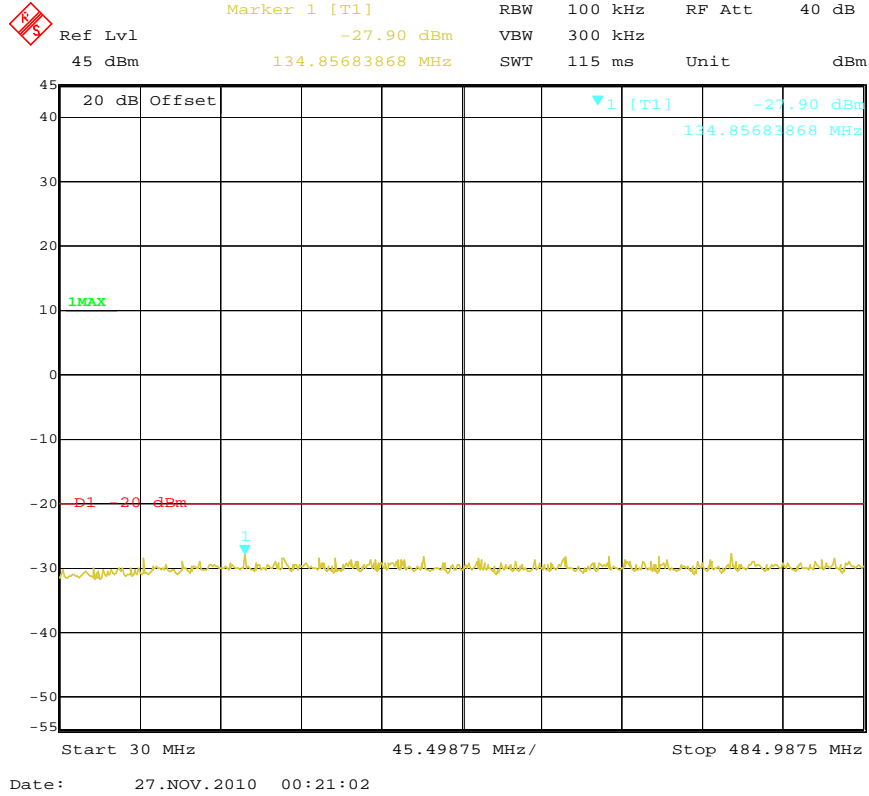

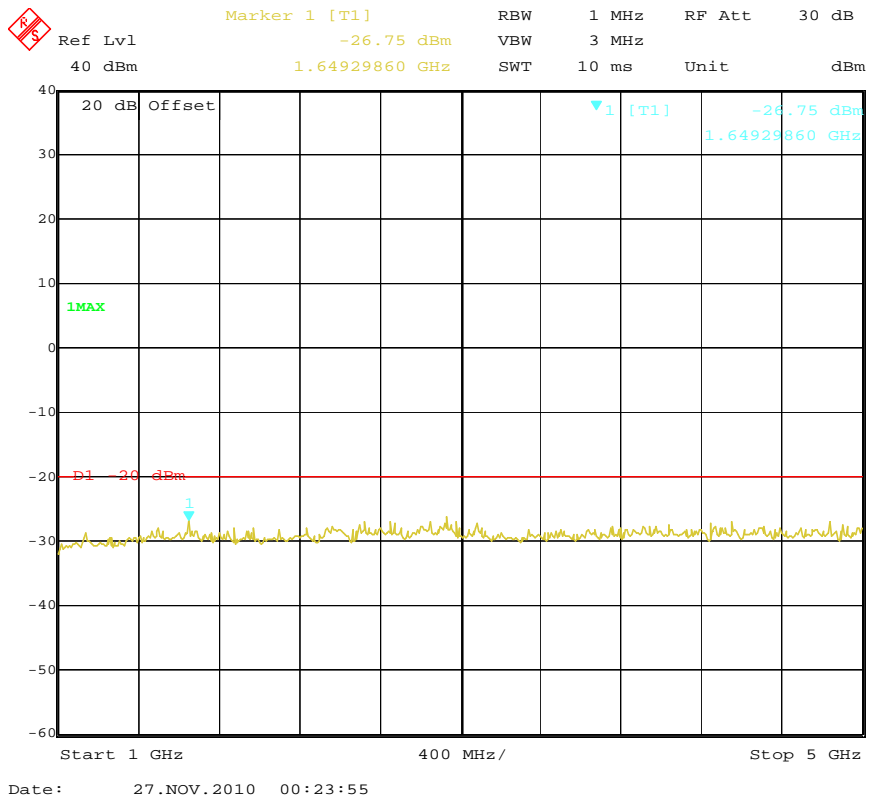
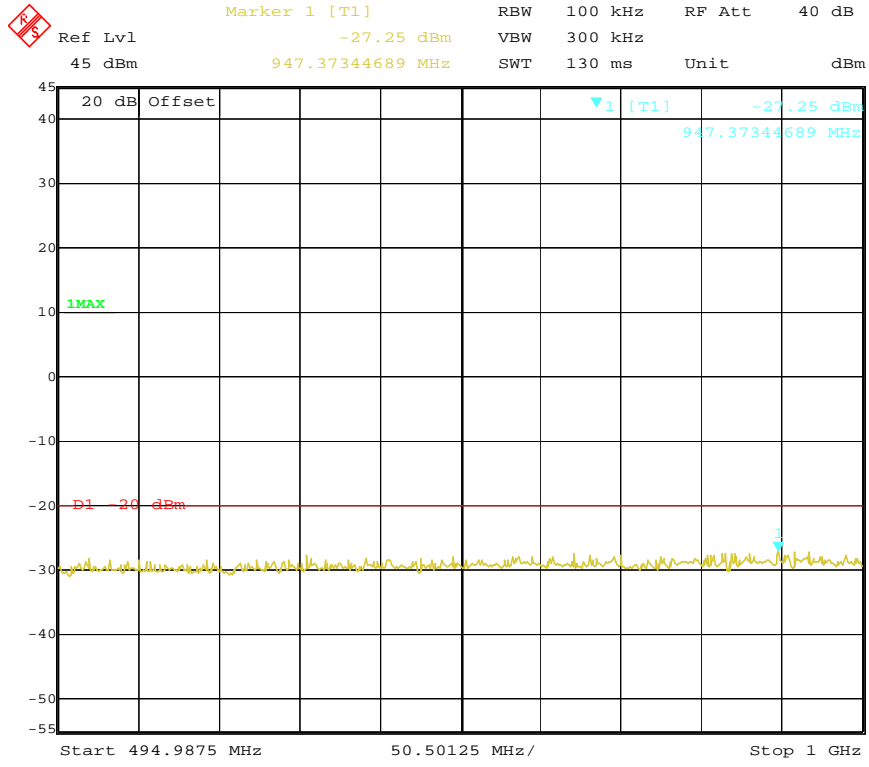

For Rated Low Power (5Watt)

Modulation Type	Channel Separation	Test Channel	Test Frequency (MHz)	Maximum Conducted Spurious Emissions Below 1GHz		Maximum Conducted Spurious Emissions Above 1GHz		FCC Limit
				Frequency (MHz)	Datum (dBm)	Frequency (MHz)	Datum (dBm)	
FM	25KHz	Low	438.1250	877.54	-26.30	2915.83	-27.34	-13dBm
Test Results				Compliance				

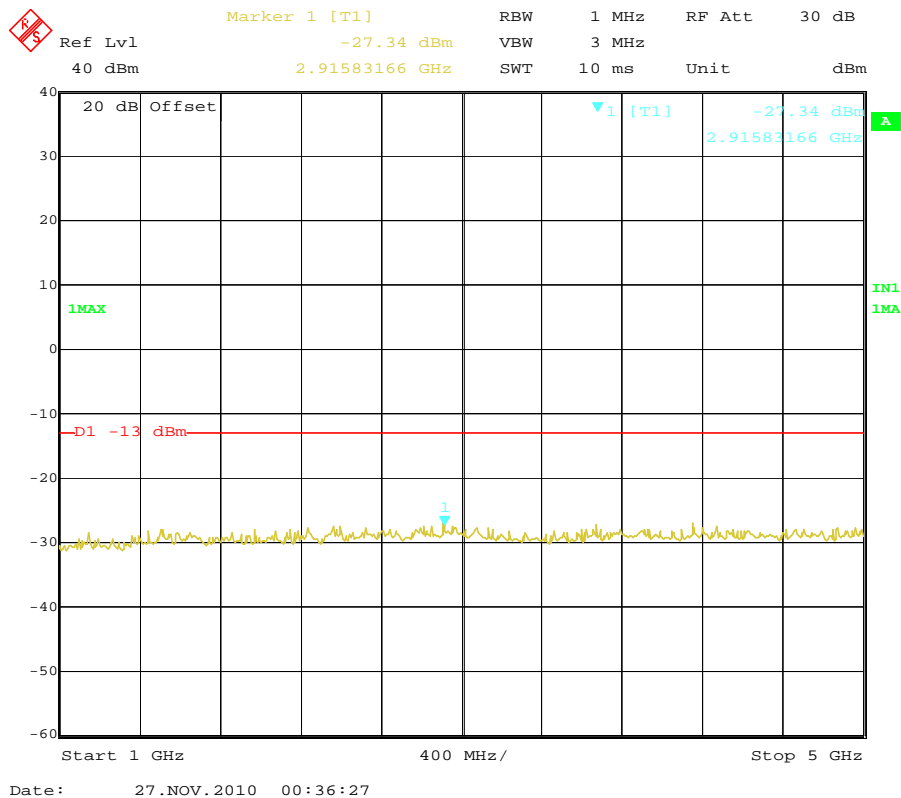
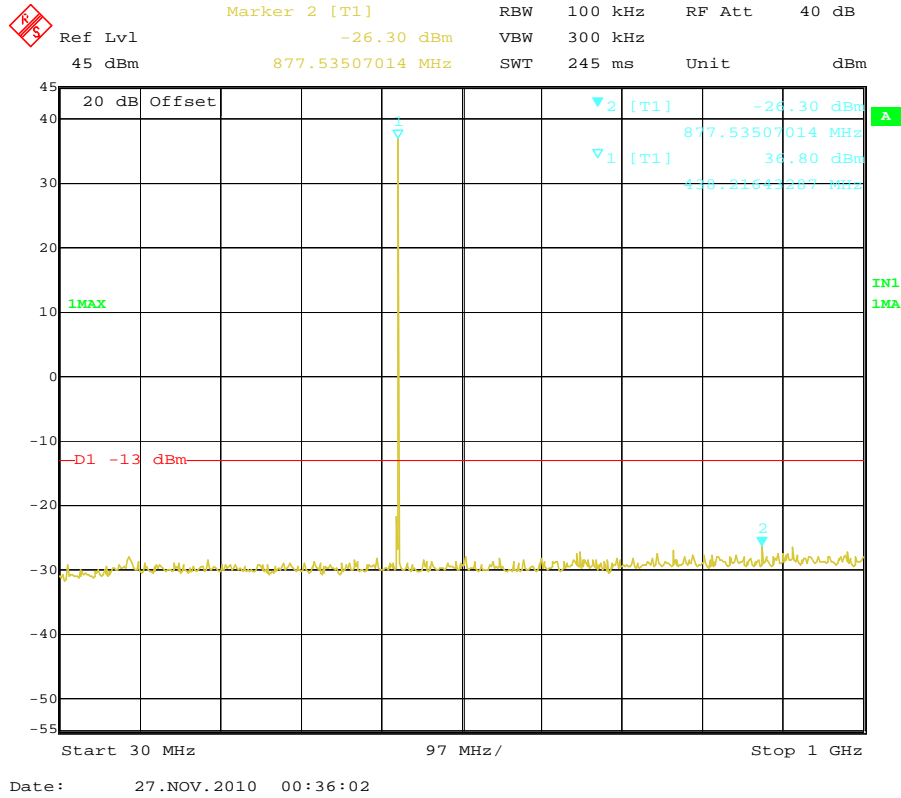

Modulation Type	Channel SpARATION	Test Channel	Test Frequency (MHz)	Maximum Conducted Spurious Emissions Below 1GHz		Maximum Conducted Spurious Emissions Above 1GHz		FCC Limit
				Frequency (MHz)	Datum (dBm)	Frequency (MHz)	Datum (dBm)	
FM	25KHz	Middle	464.1250	930.02	-27.38	2923.85	-26.93	-13dBm
Test Results				Compliance				

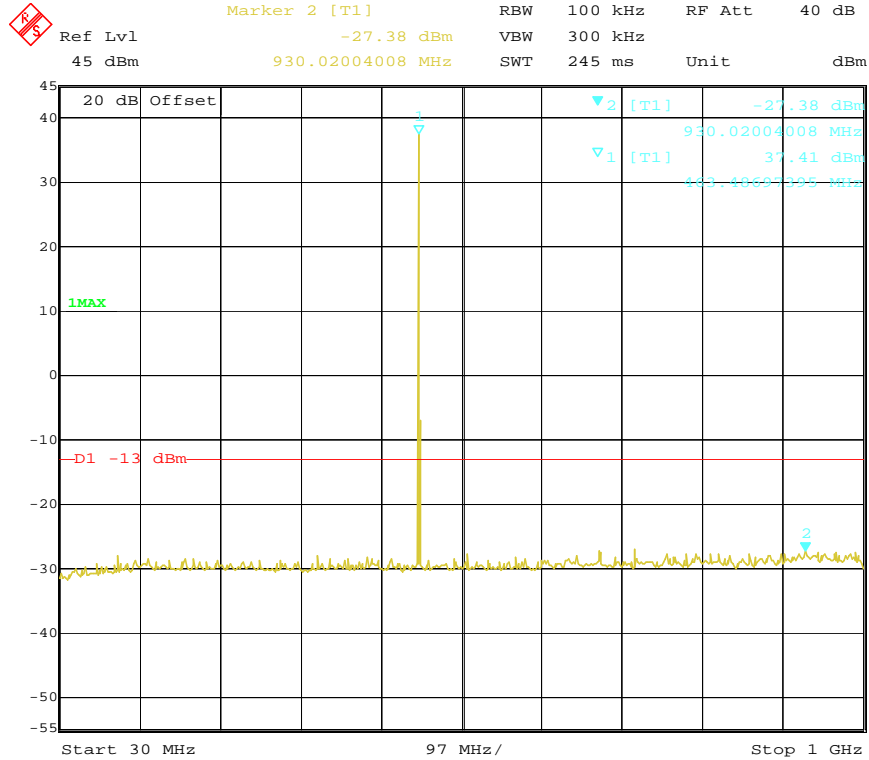

Date: 27.NOV.2010 00:37:32

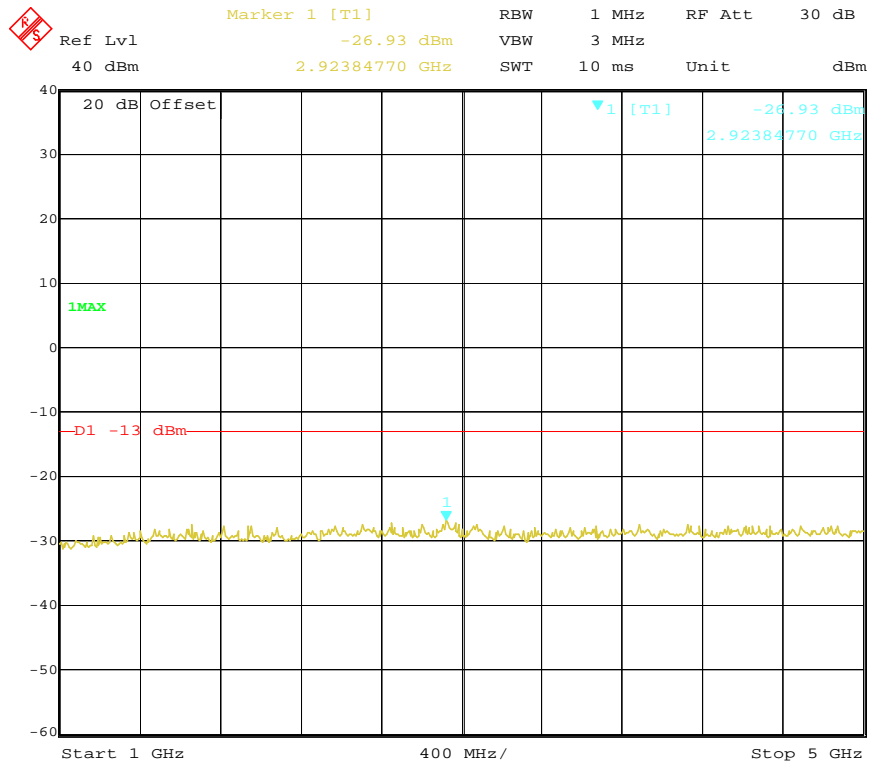

Date: 27.NOV.2010 00:37:01

Modulation Type	Channel Separation	Test Channel	Test Frequency (MHz)	Maximum Conducted Spurious Emissions Below 1GHz		Maximum Conducted Spurious Emissions Above 1GHz		FCC Limit
				Frequency (MHz)	Datum (dBm)	Frequency (MHz)	Datum (dBm)	
FM	25KHz	High	489.9875	912.53	-27.22	4438.88	-27.31	-13dBm
Test Results				Compliance				

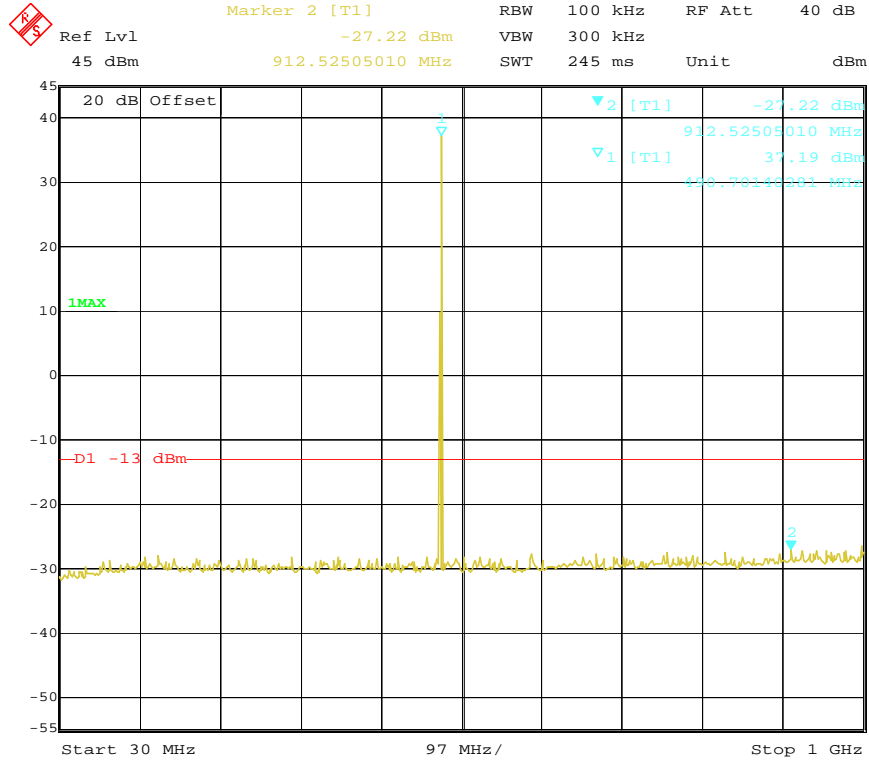

Date: 27.NOV.2010 00:38:06

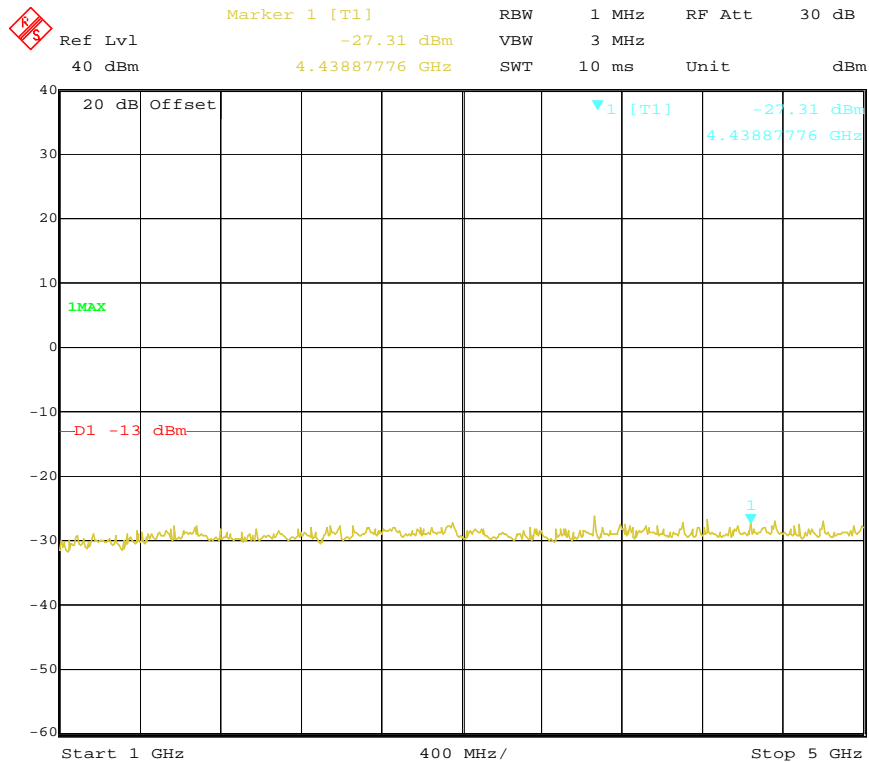

Date: 27.NOV.2010 00:38:43

Modulation Type	Channel SpARATION	Test Channel	Test Frequency (MHz)	Maximum Conducted Spurious Emissions Below 1GHz		Maximum Conducted Spurious Emissions Above 1GHz		FCC Limit
				Frequency (MHz)	Datum (dBm)	Frequency (MHz)	Datum (dBm)	
FM	12.5KHz	Low	438.1250	877.54	-26.31	2947.90	-26.44	-20dBm
Test Results				Compliance				

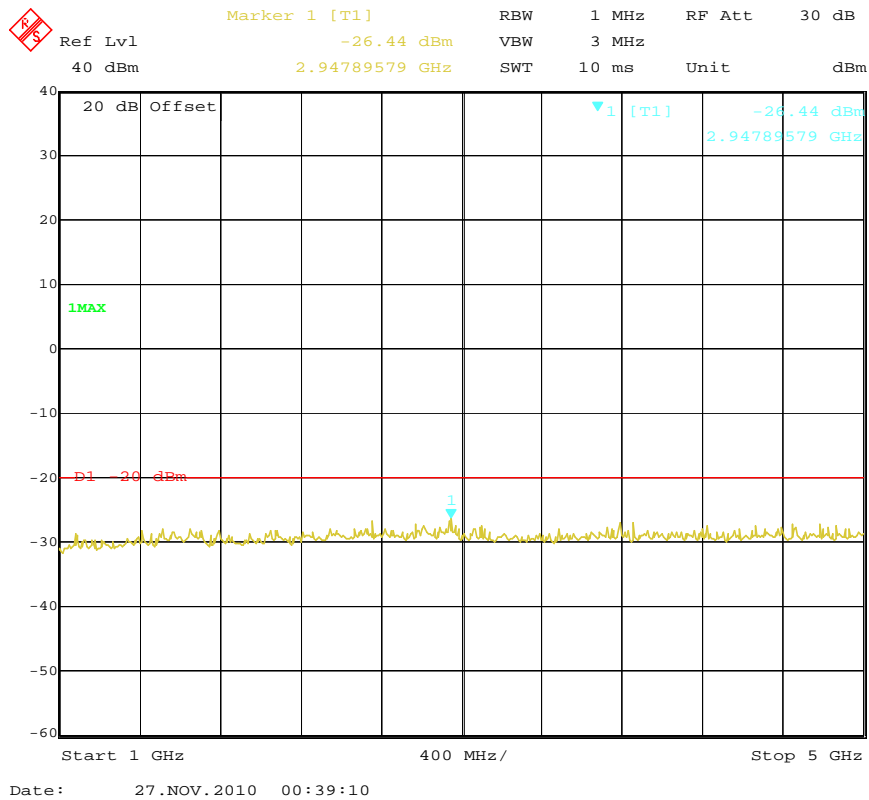
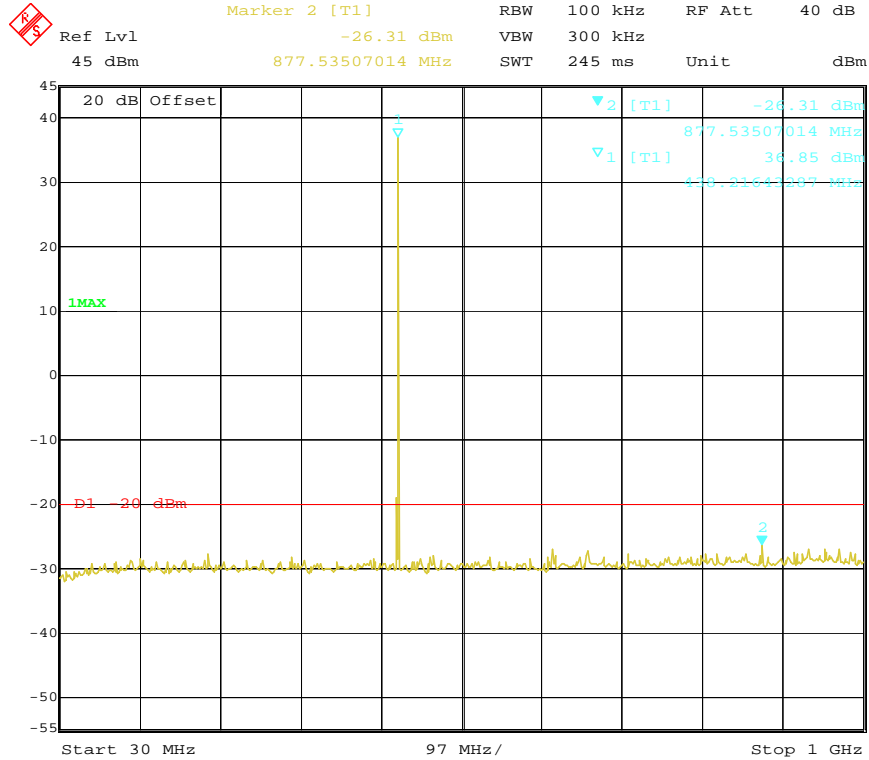

Modulation Type	Channel SpARATION	Test Channel	Test Frequency (MHz)	Maximum Conducted Spurious Emissions Below 1GHz		Maximum Conducted Spurious Emissions Above 1GHz		FCC Limit
				Frequency (MHz)	Datum (dBm)	Frequency (MHz)	Datum (dBm)	
FM	12.5KHz	Middle	464.1250	920.30	-26.94	4927.86	-26.38	-20dBm
Test Results				Compliance				

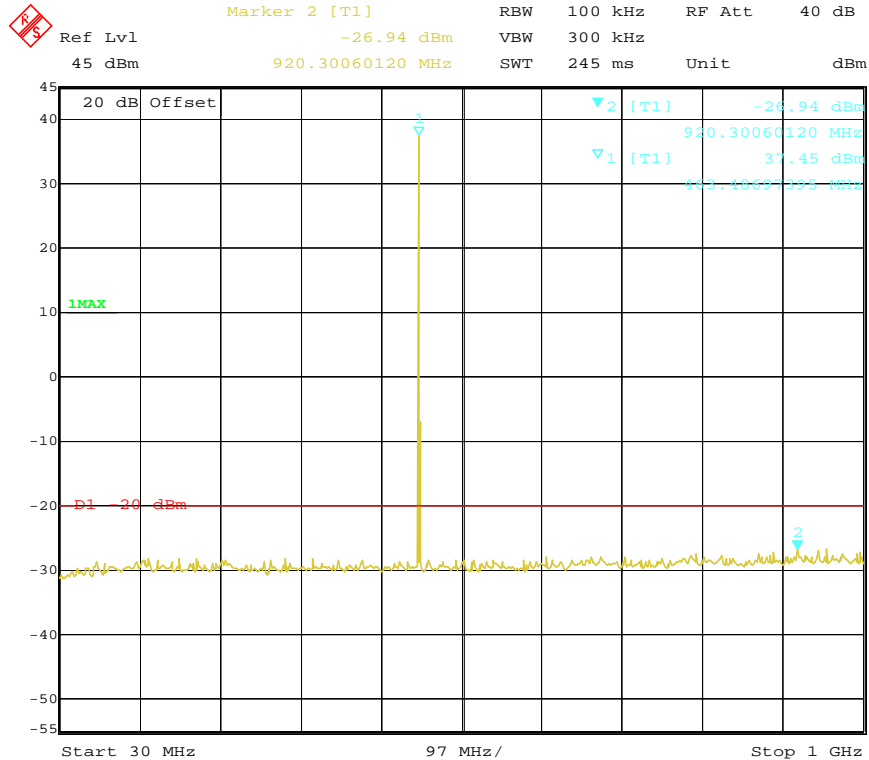

Date: 27.NOV.2010 00:40:23

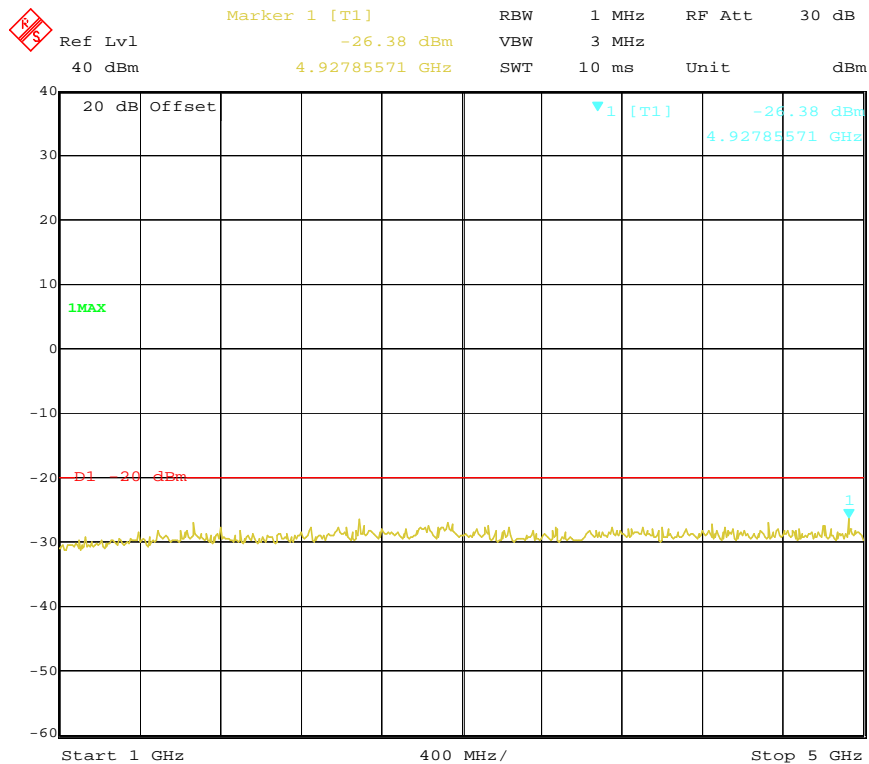

Date: 27.NOV.2010 00:41:00

Modulation Type	Channel SpARATION	Test Channel	Test Frequency (MHz)	Maximum Conducted Spurious Emissions Below 1GHz		Maximum Conducted Spurious Emissions Above 1GHz		FCC Limit
				Frequency (MHz)	Datum (dBm)	Frequency (MHz)	Datum (dBm)	
FM	12.5KHz	High	489.9875	980.56	-25.46	3749.50	-26.94	-20dBm
Test Results				Compliance				

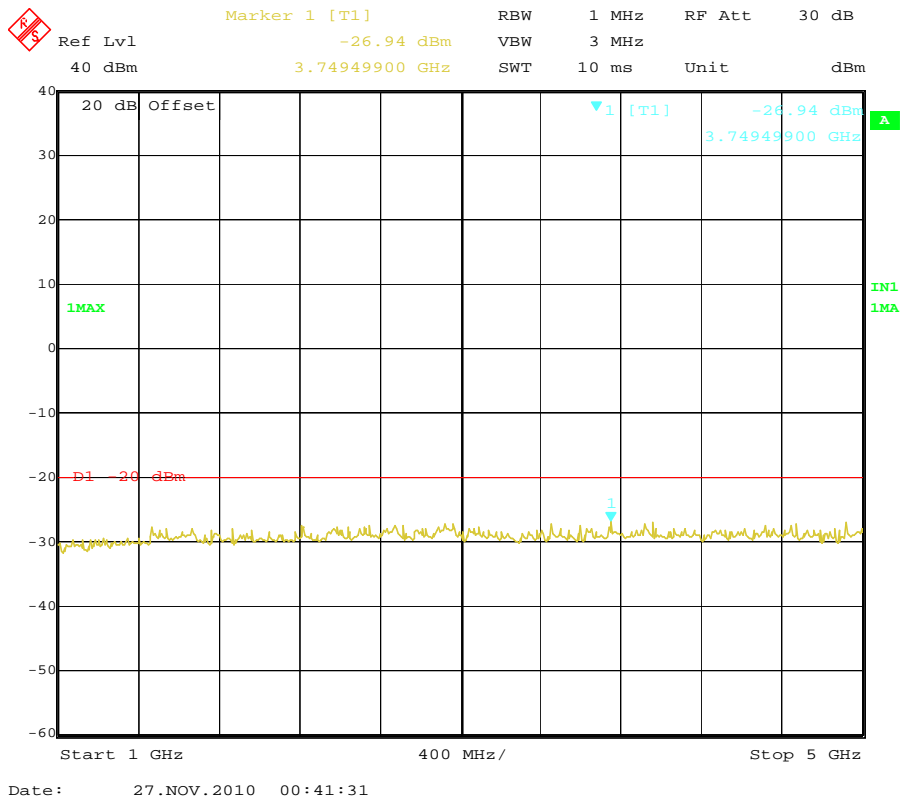
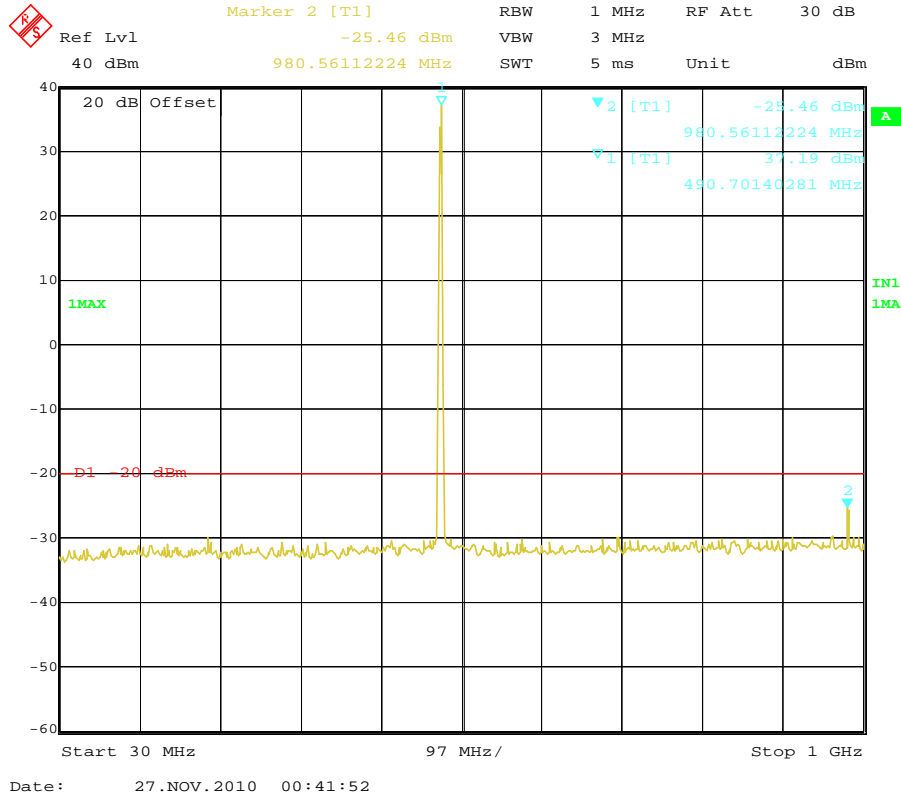

For IC

For Rated High Power (25Watt)

Modulation Type	Channel Separation	Test Channel	Test Frequency (MHz)	Maximum Conducted Spurious Emissions Below 1GHz		Maximum Conducted Spurious Emissions Above 1GHz		FCC Limit
				Frequency (MHz)	Datum (dBm)	Frequency (MHz)	Datum (dBm)	
FM	25KHz	Low	450.1250	674.61	-18.66	2939.88	-26.53	-13dBm
Test Results				Compliance				

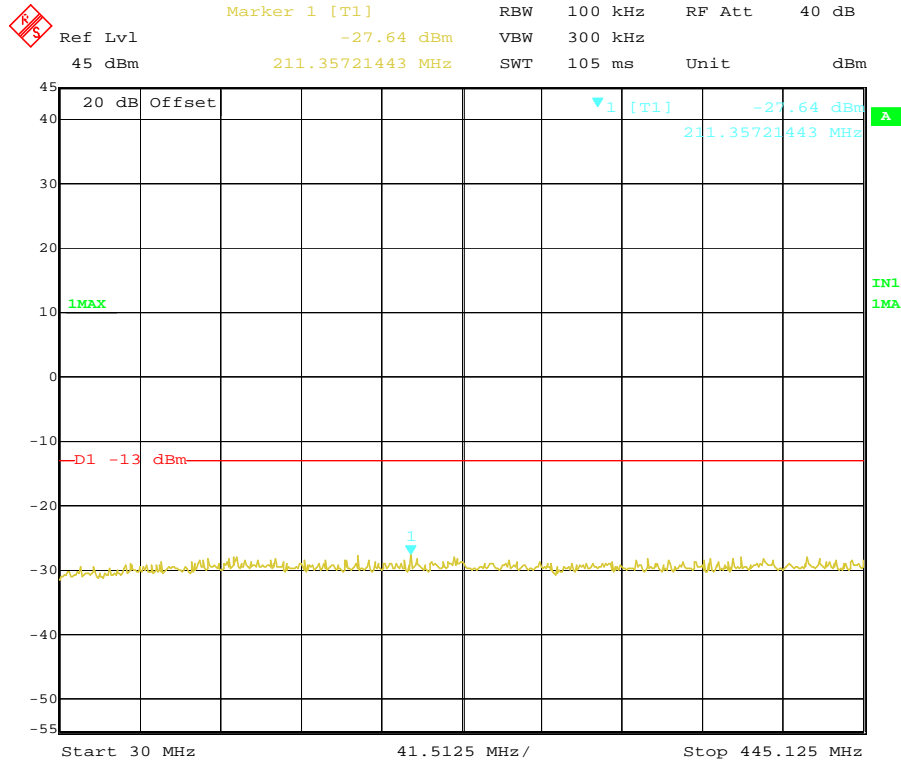

Date: 27.NOV.2010 01:08:07

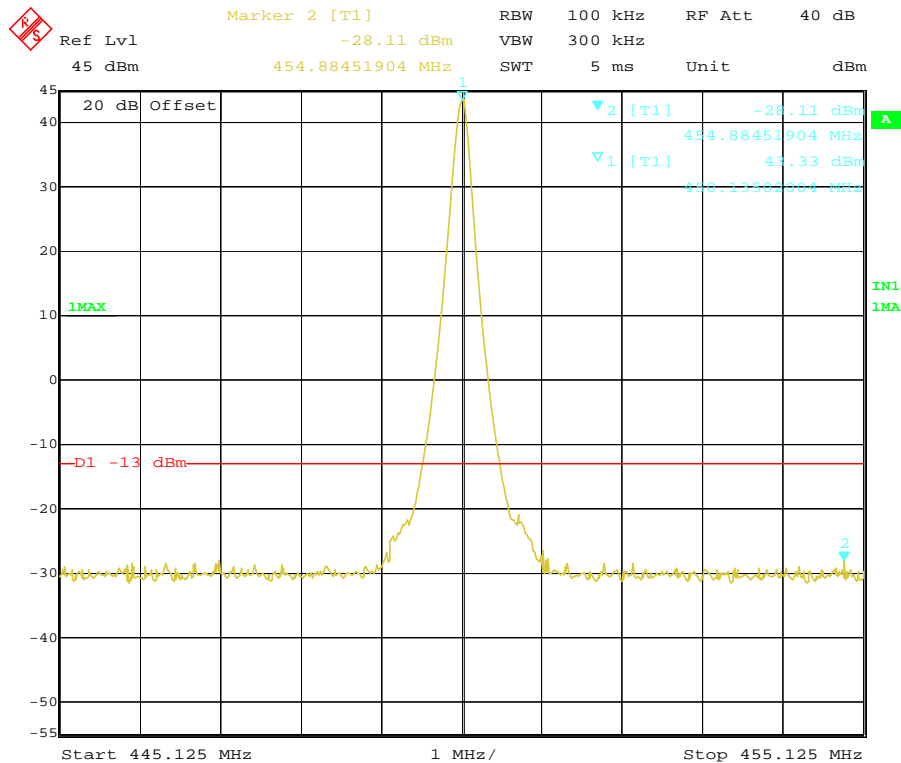

Date: 27.NOV.2010 01:08:53

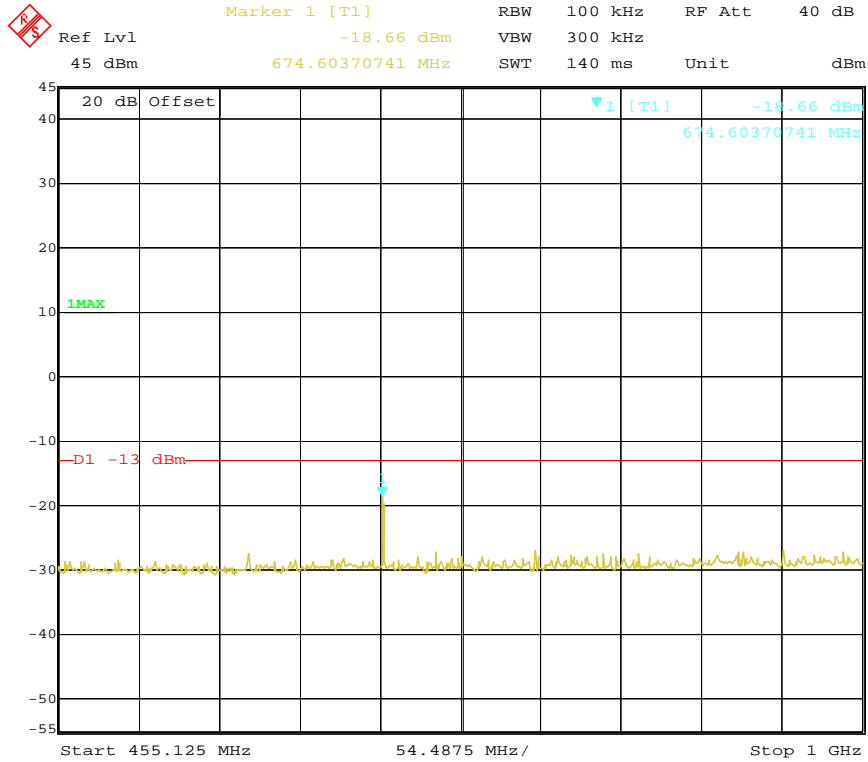

Date: 27.NOV.2010 01:09:39

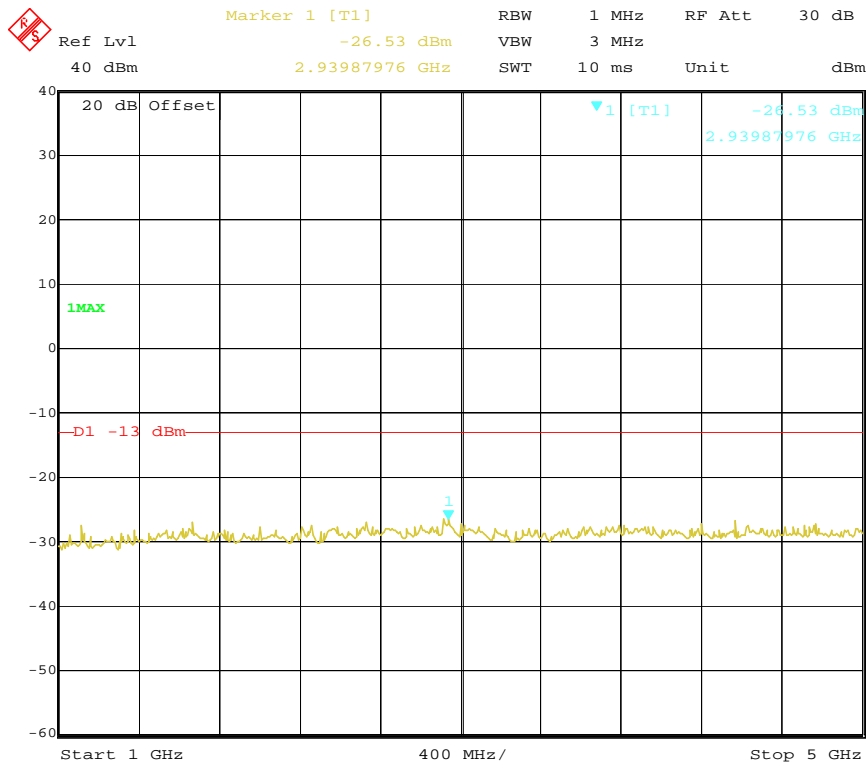

Date: 27.NOV.2010 01:10:16

Modulation Type	Channel SpARATION	Test Channel	Test Frequency (MHz)	Maximum Conducted Spurious Emissions Below 1GHz		Maximum Conducted Spurious Emissions Above 1GHz		FCC Limit
				Frequency (MHz)	Datum (dBm)	Frequency (MHz)	Datum (dBm)	
FM	25KHz	Middle	460.1250	959.27	-26.27	1367.75	-26.99	-13dBm
Test Results				Compliance				

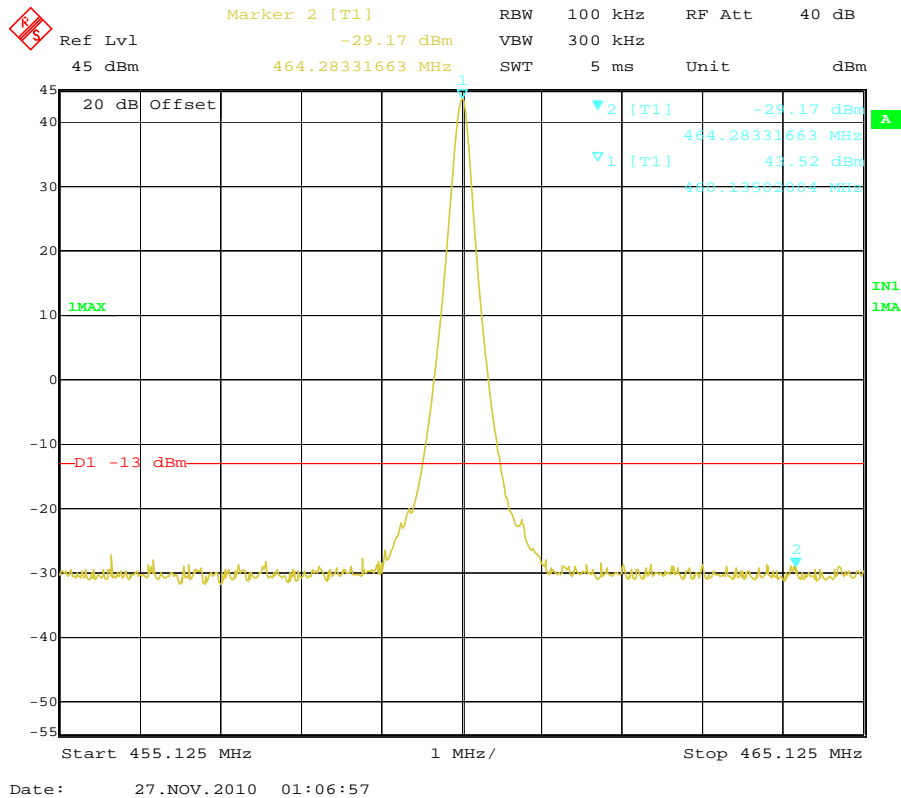
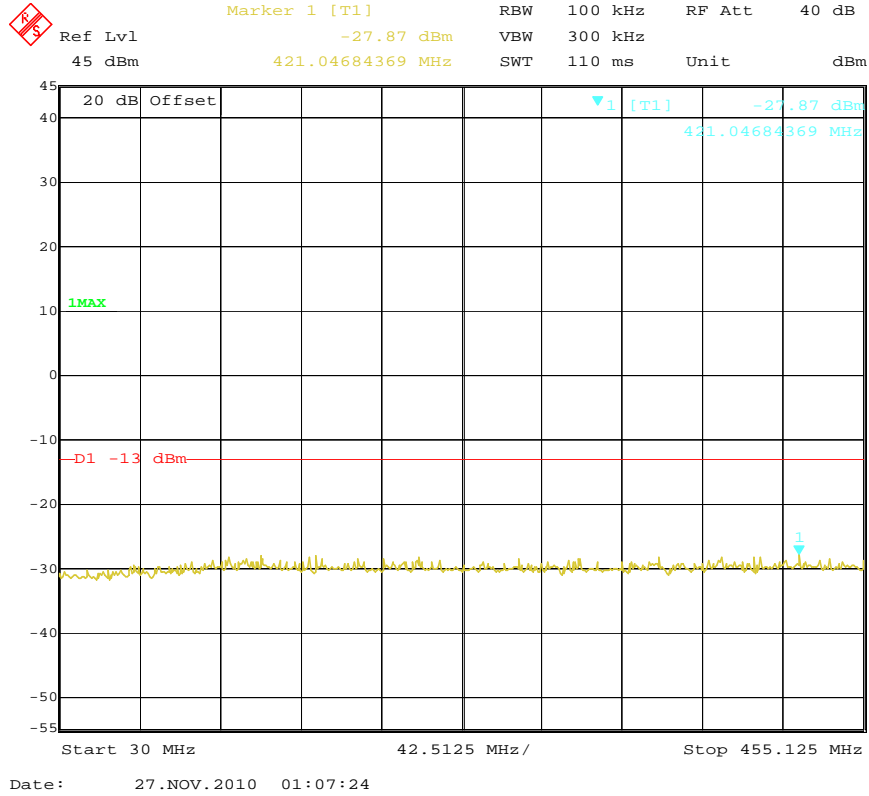

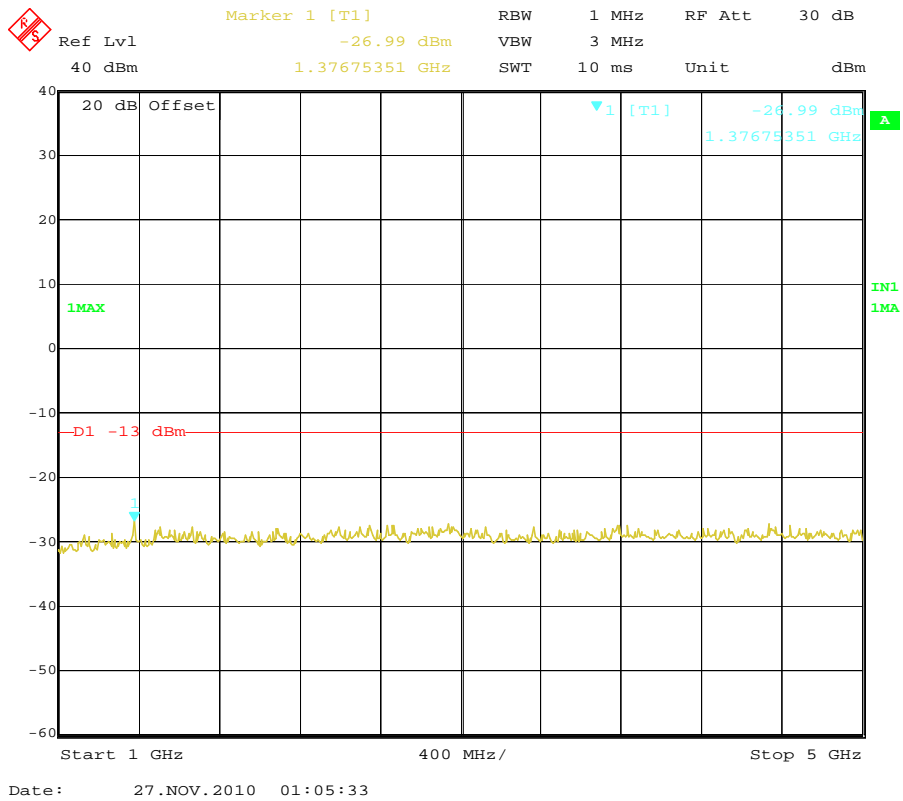
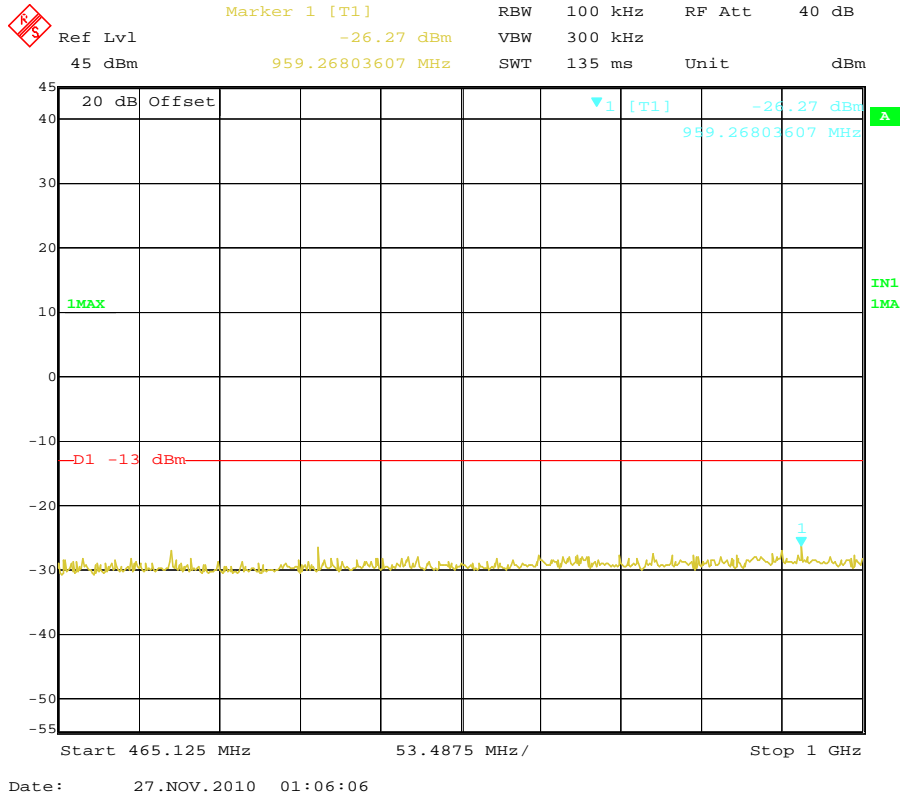

Modulation Type	Channel Separation	Test Channel	Test Frequency (MHz)	Maximum Conducted Spurious Emissions Below 1GHz		Maximum Conducted Spurious Emissions Above 1GHz		FCC Limit
				Frequency (MHz)	Datum (dBm)	Frequency (MHz)	Datum (dBm)	
FM	25KHz	High	469.9875	966.33	-26.99	4519.04	-26.90	-13dBm
Test Results				Compliance				

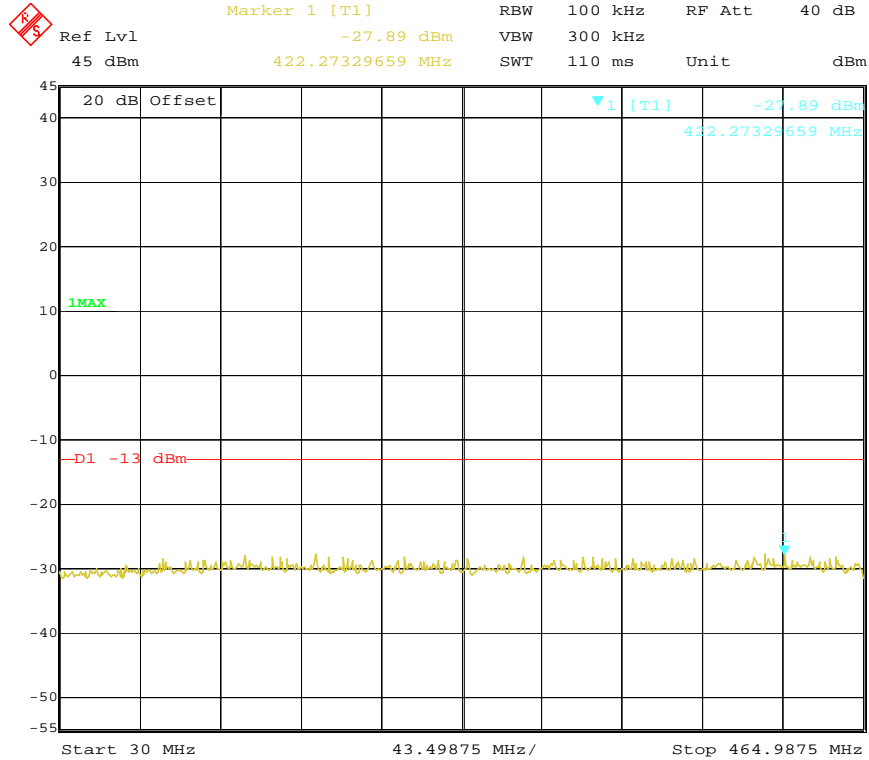

Date: 27.NOV.2010 01:03:15

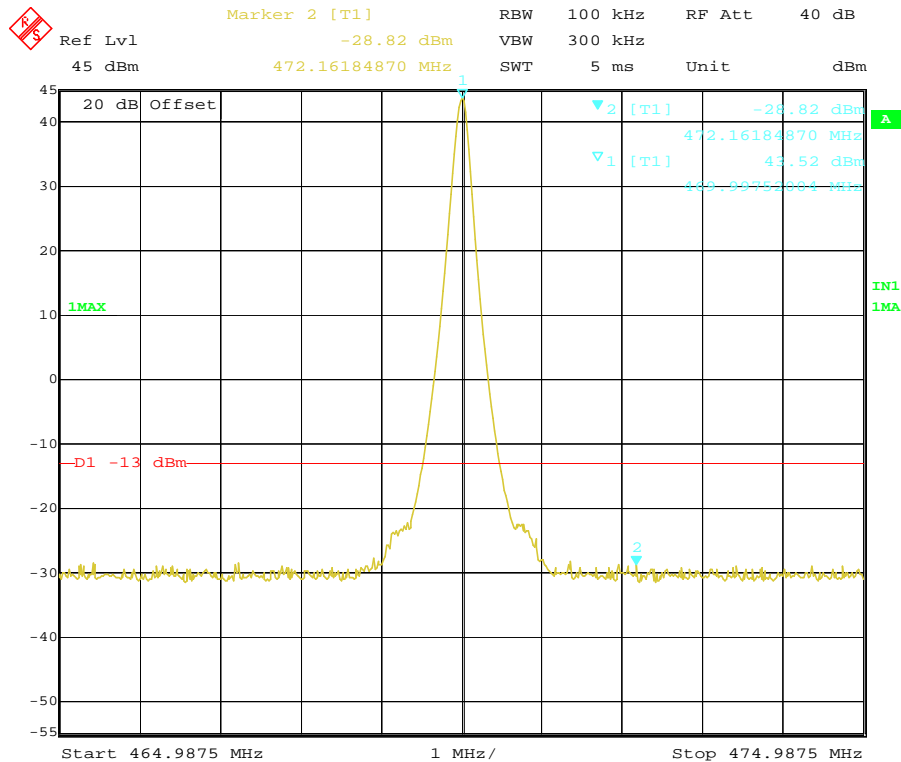

Date: 27.NOV.2010 01:03:48

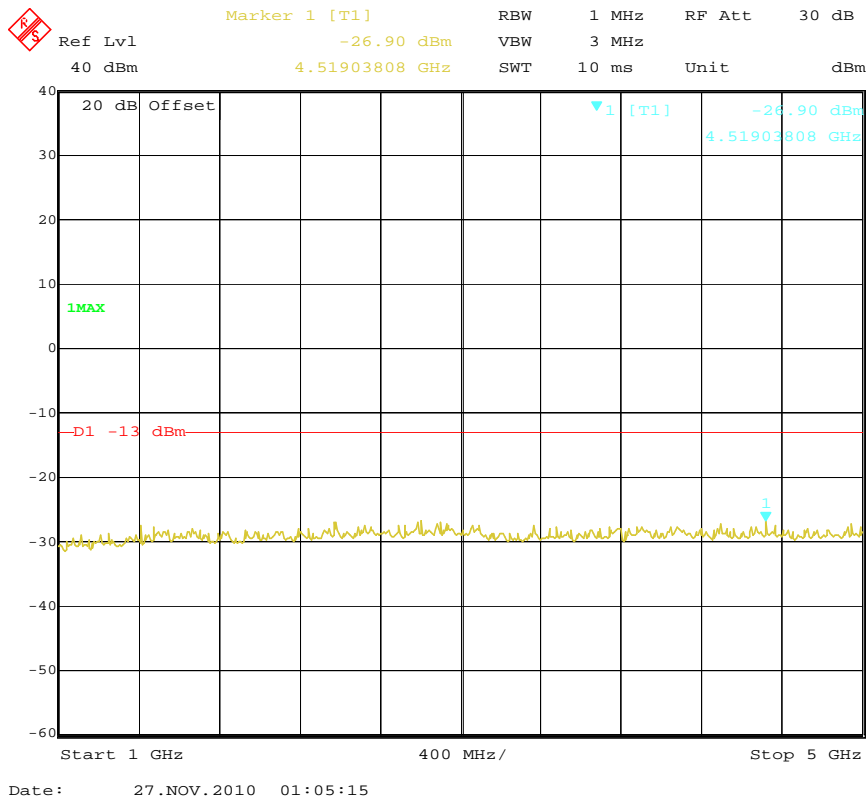
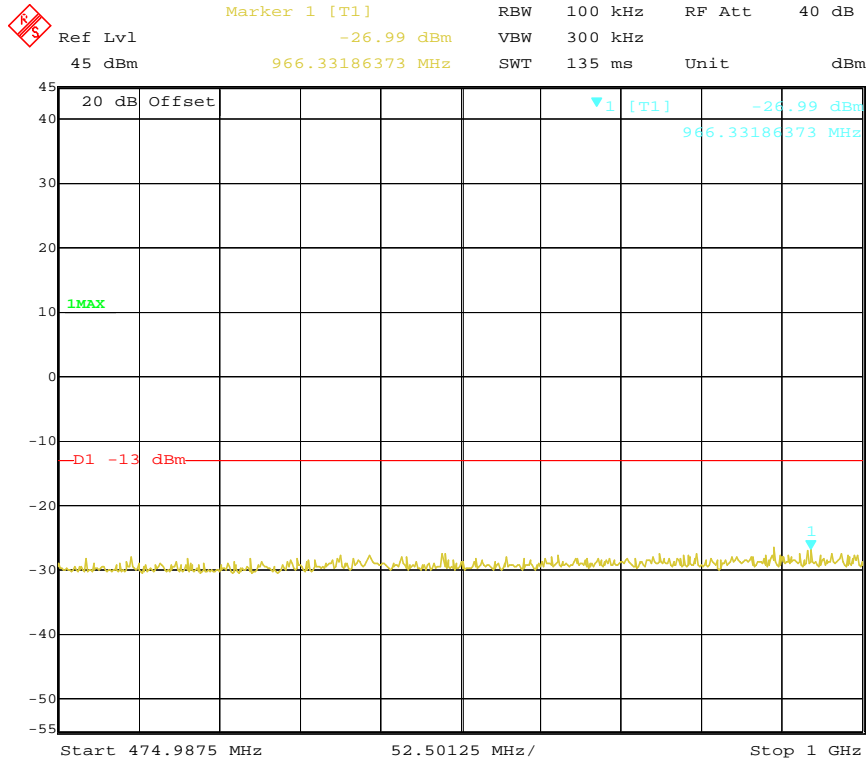

Modulation Type	Channel Separation	Test Channel	Test Frequency (MHz)	Maximum Conducted Spurious Emissions Below 1GHz		Maximum Conducted Spurious Emissions Above 1GHz		FCC Limit
				Frequency (MHz)	Datum (dBm)	Frequency (MHz)	Datum (dBm)	
FM	12.5KHz	Low	450.1250	674.60	-25.33	2955.91	-26.85	-20dBm
Test Results				Compliance				

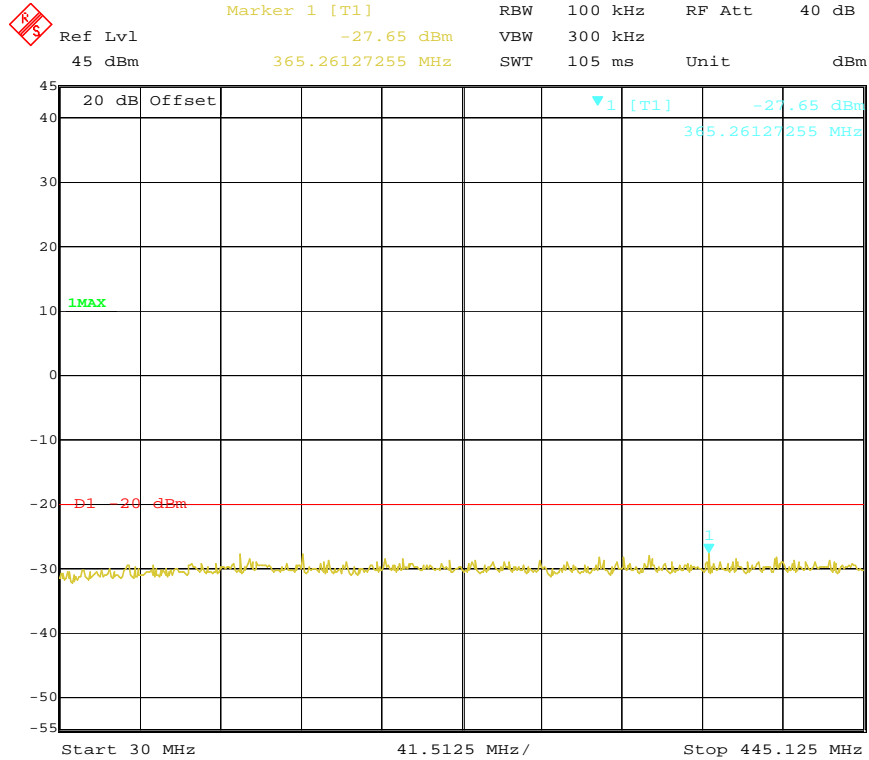

Date: 27.NOV.2010 01:02:40

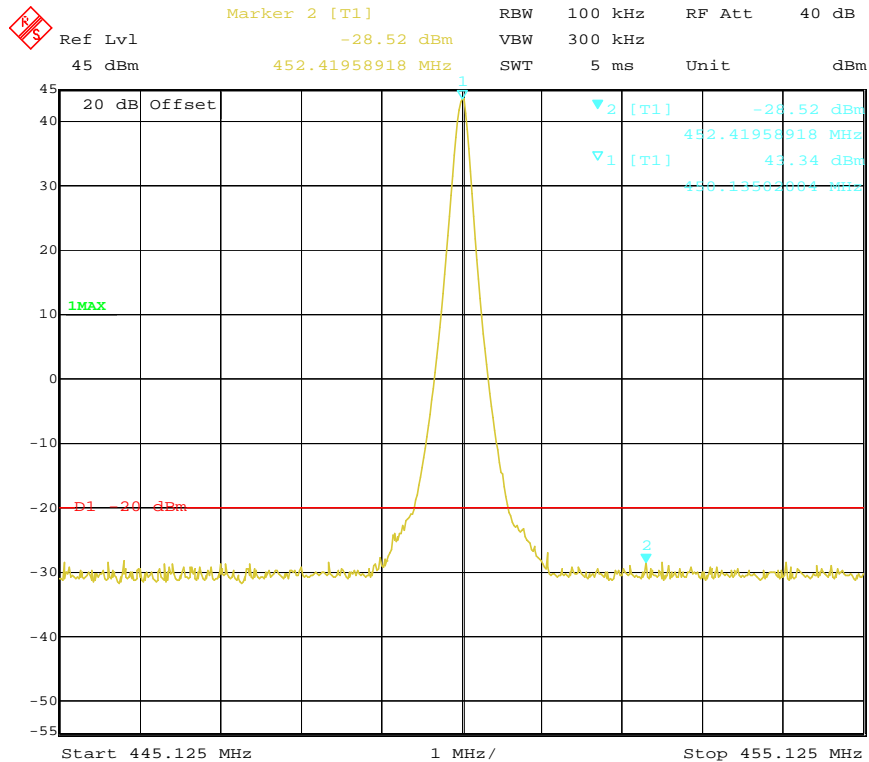

Date: 27.NOV.2010 01:02:18

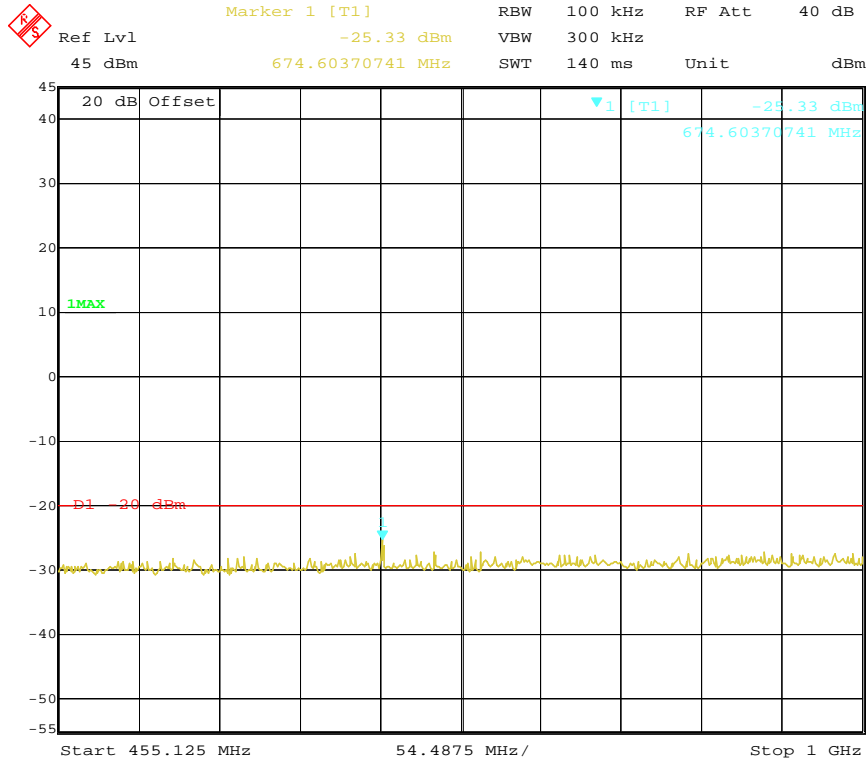

Date: 27.NOV.2010 01:01:28

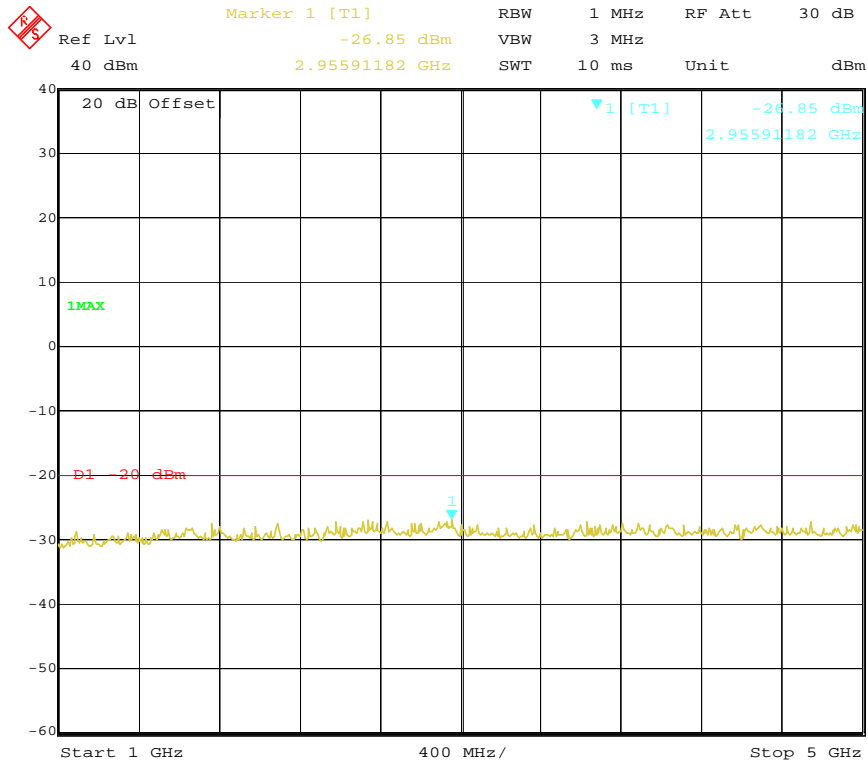

Date: 27.NOV.2010 00:59:37

Modulation Type	Channel SpARATION	Test Channel	Test Frequency (MHz)	Maximum Conducted Spurious Emissions Below 1GHz		Maximum Conducted Spurious Emissions Above 1GHz		FCC Limit
				Frequency (MHz)	Datum (dBm)	Frequency (MHz)	Datum (dBm)	
FM	12.5KHz	Middle	460.1250	998.93	-26.92	1376.75	-26.54	-20dBm
Test Results				Compliance				

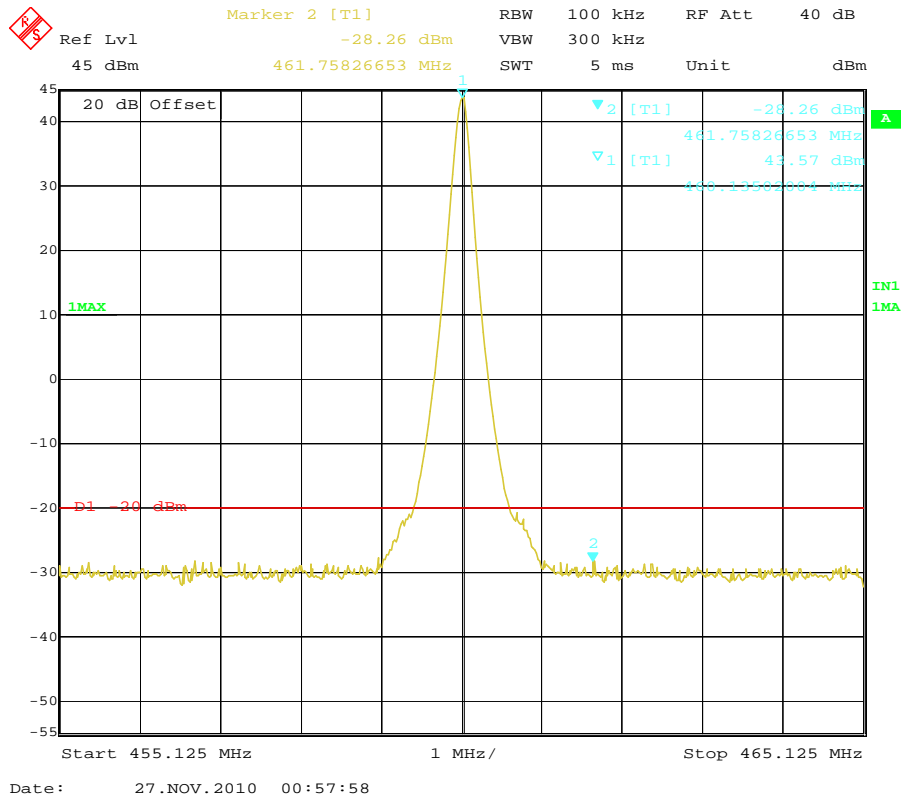
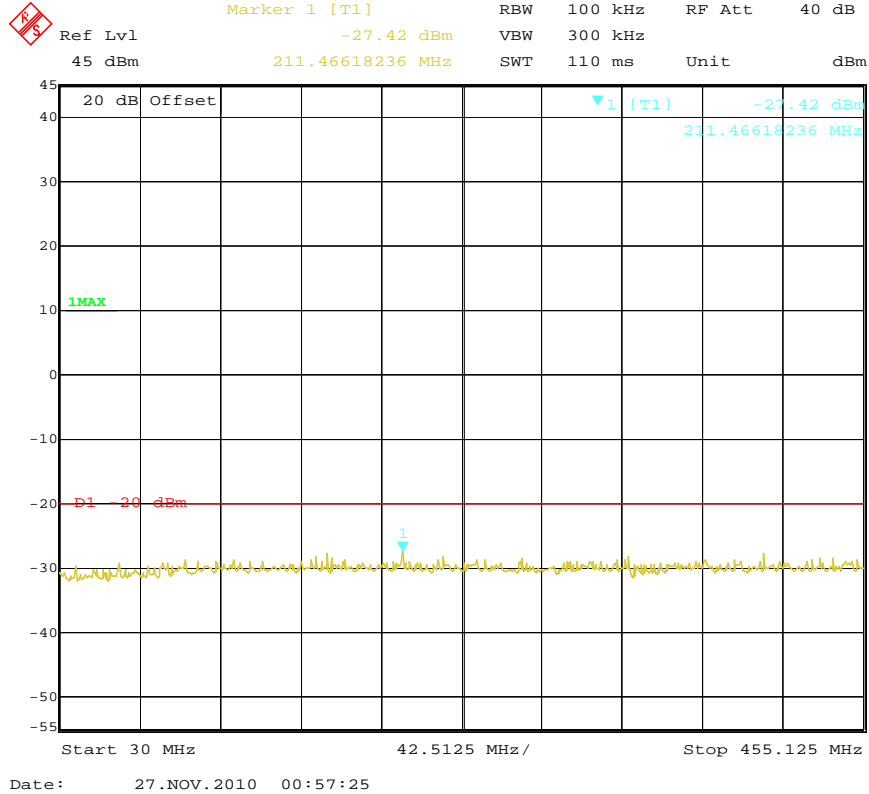

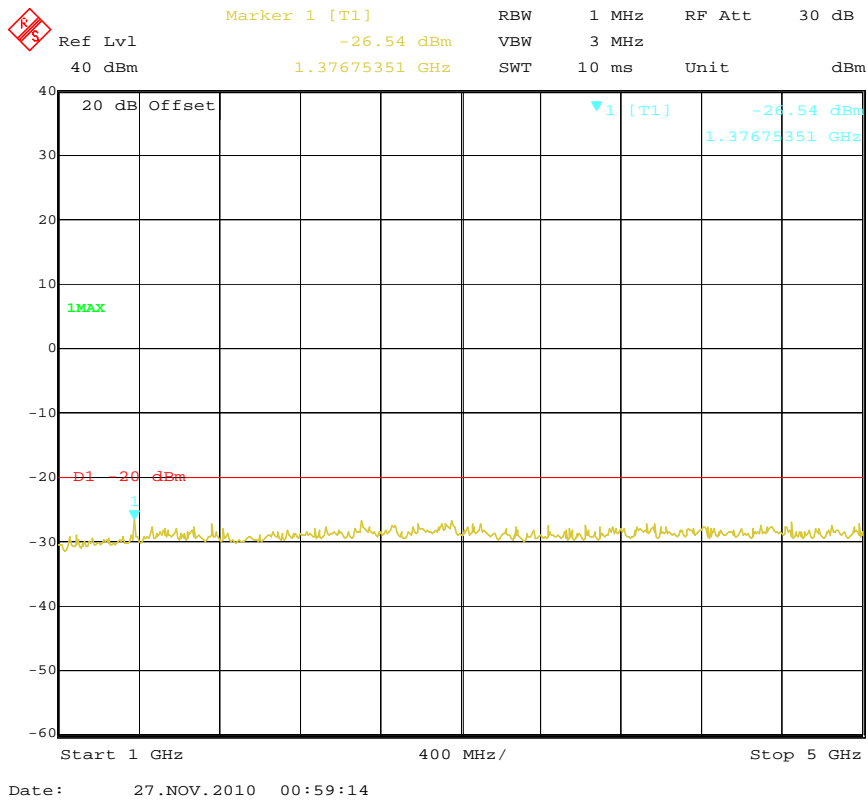
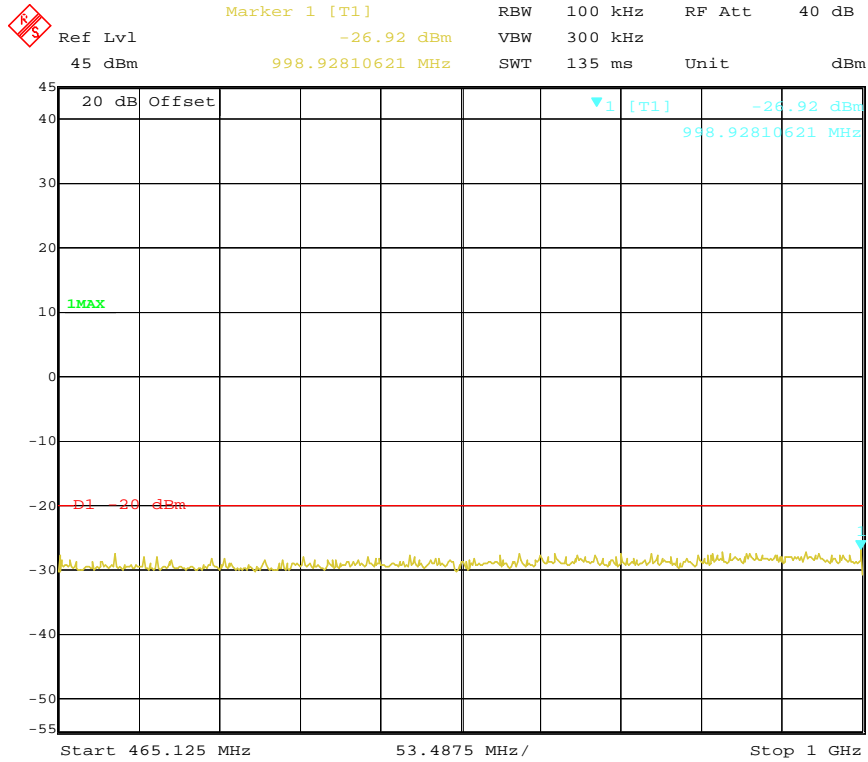

Modulation Type	Channel SpARATION	Test Channel	Test Frequency (MHz)	Maximum Conducted Spurious Emissions Below 1GHz		Maximum Conducted Spurious Emissions Above 1GHz		FCC Limit
				Frequency (MHz)	Datum (dBm)	Frequency (MHz)	Datum (dBm)	
FM	12.5KHz	High	469.9875	907.41	-27.13	4519.04	-26.46	-20dBm
Test Results				Compliance				

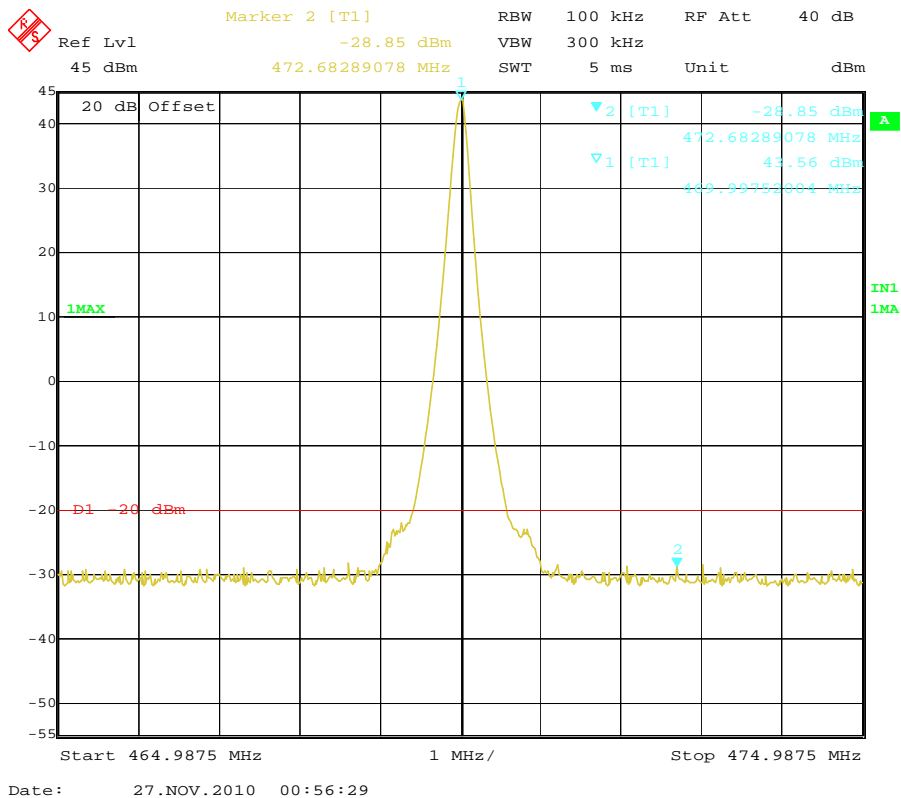
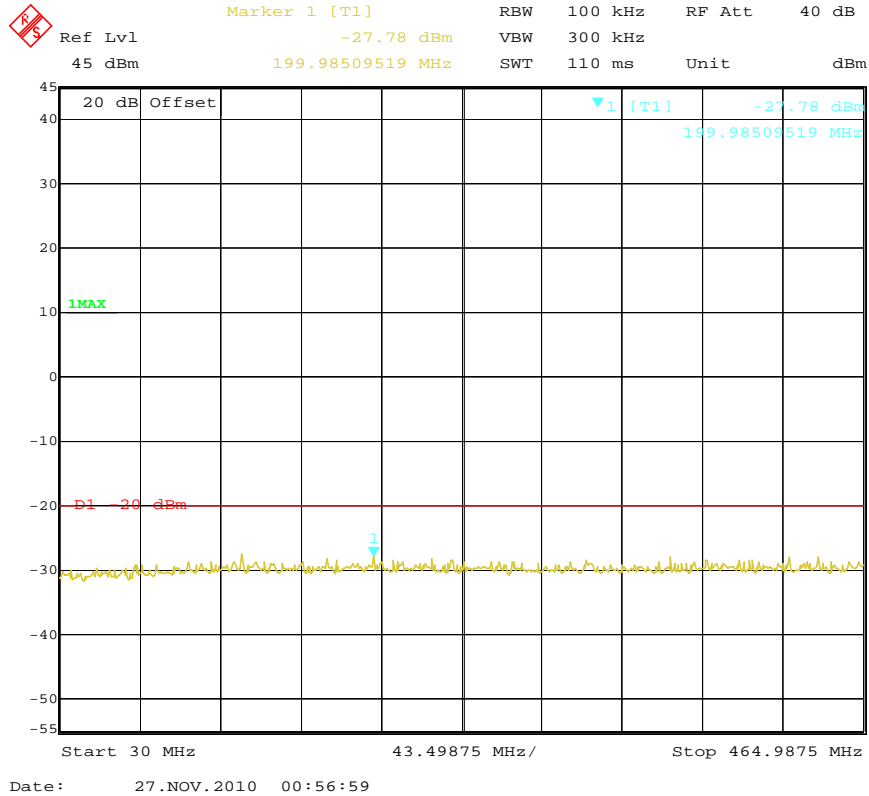

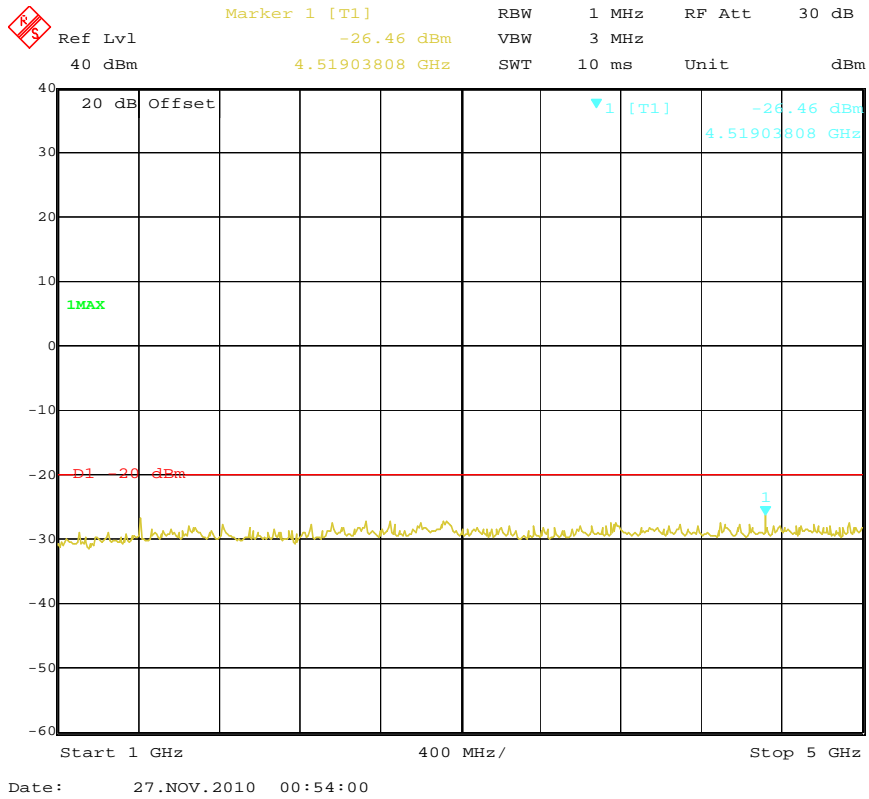
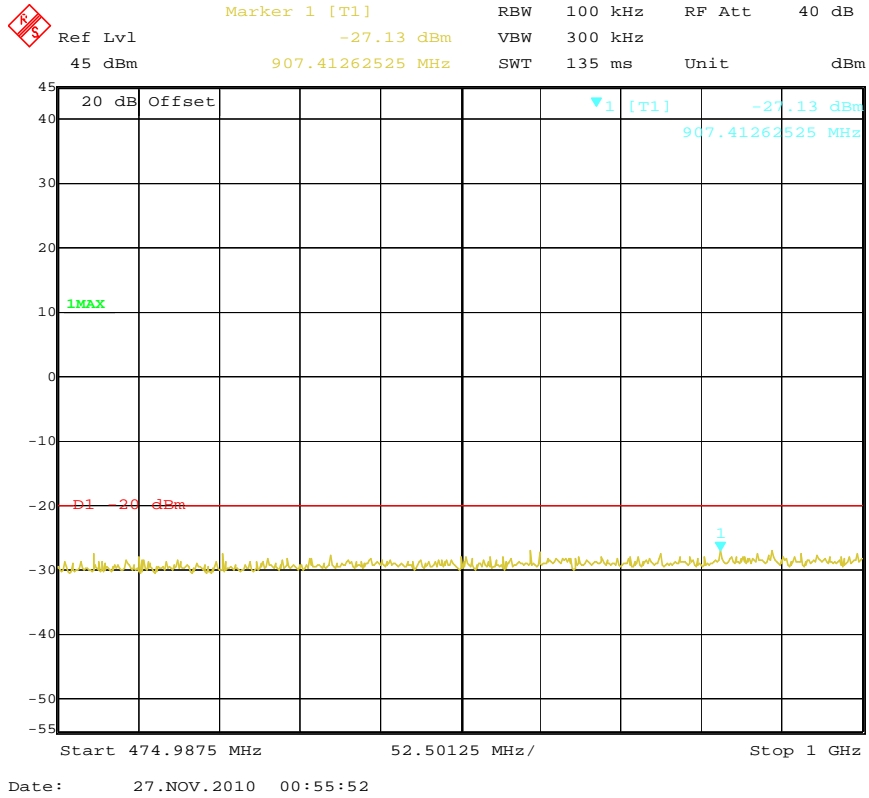

For Rated Low Power (5Watt)

Modulation Type	Channel Separation	Test Channel	Test Frequency (MHz)	Maximum Conducted Spurious Emissions Below 1GHz		Maximum Conducted Spurious Emissions Above 1GHz		FCC Limit
				Frequency (MHz)	Datum (dBm)	Frequency (MHz)	Datum (dBm)	
FM	25KHz	Low	450.1250	953.35	-26.55	4543.09	-27.33	-13dBm
Test Results				Compliance				

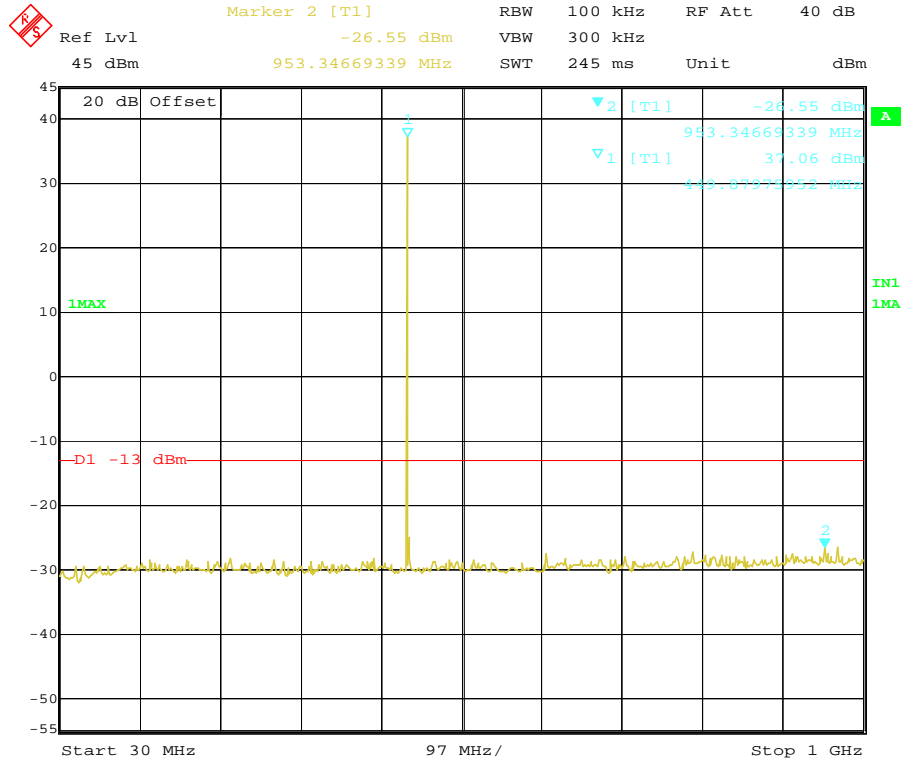

Date: 27.NOV.2010 00:49:07

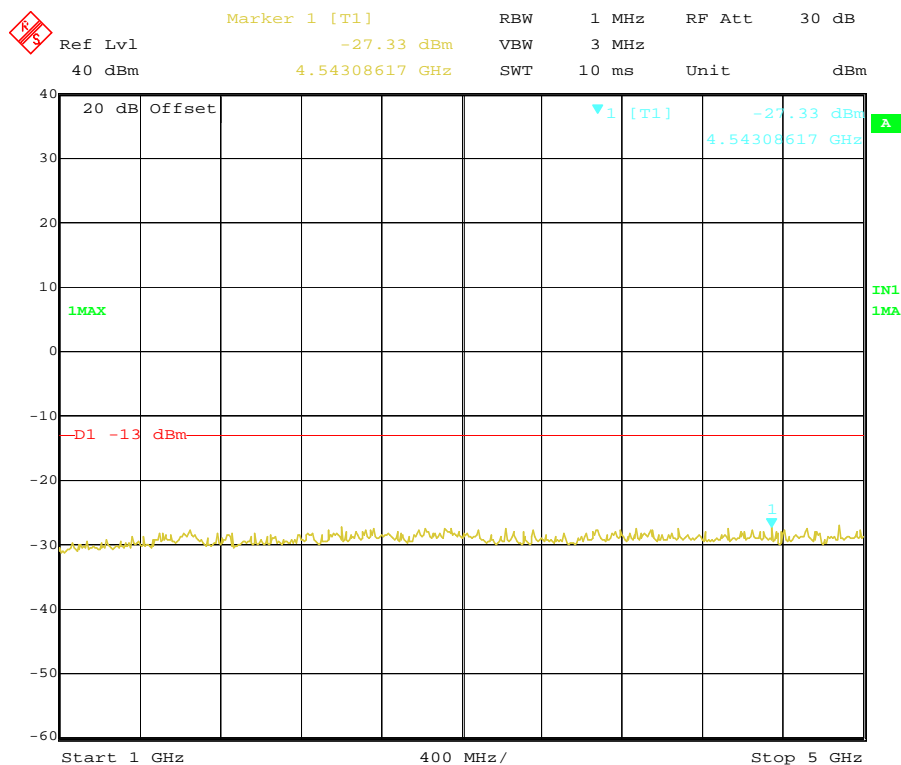

Date: 27.NOV.2010 00:48:26

Modulation Type	Channel SpARATION	Test Channel	Test Frequency (MHz)	Maximum Conducted Spurious Emissions Below 1GHz		Maximum Conducted Spurious Emissions Above 1GHz		FCC Limit
				Frequency (MHz)	Datum (dBm)	Frequency (MHz)	Datum (dBm)	
FM	25KHz	Middle	460.1250	966.95	-27.41	2995.99	-27.02	-13dBm
Test Results				Compliance				

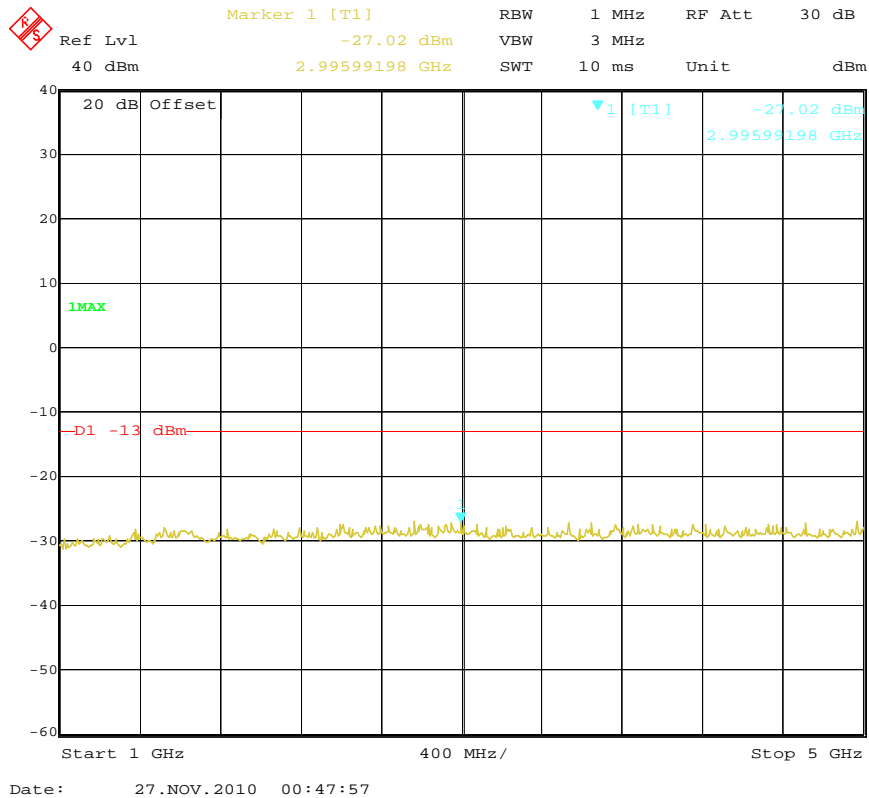
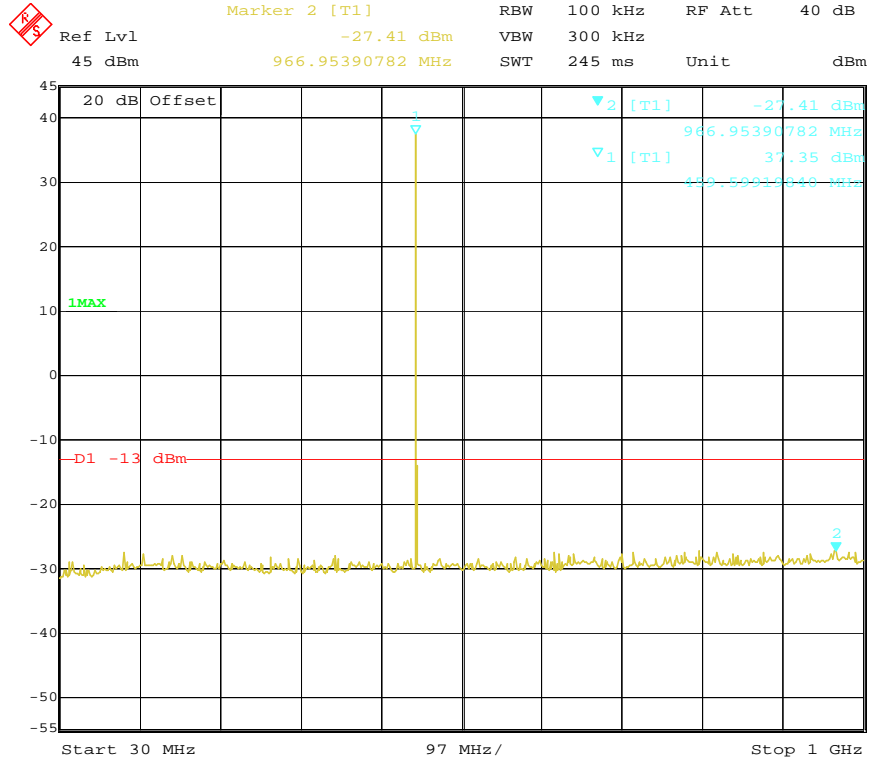

Modulation Type	Channel SpARATION	Test Channel	Test Frequency (MHz)	Maximum Conducted Spurious Emissions Below 1GHz		Maximum Conducted Spurious Emissions Above 1GHz		FCC Limit
				Frequency (MHz)	Datum (dBm)	Frequency (MHz)	Datum (dBm)	
FM	25KHz	High	469.9875	970.84	-27.22	2899.80	-27.07	-13dBm
Test Results				Compliance				

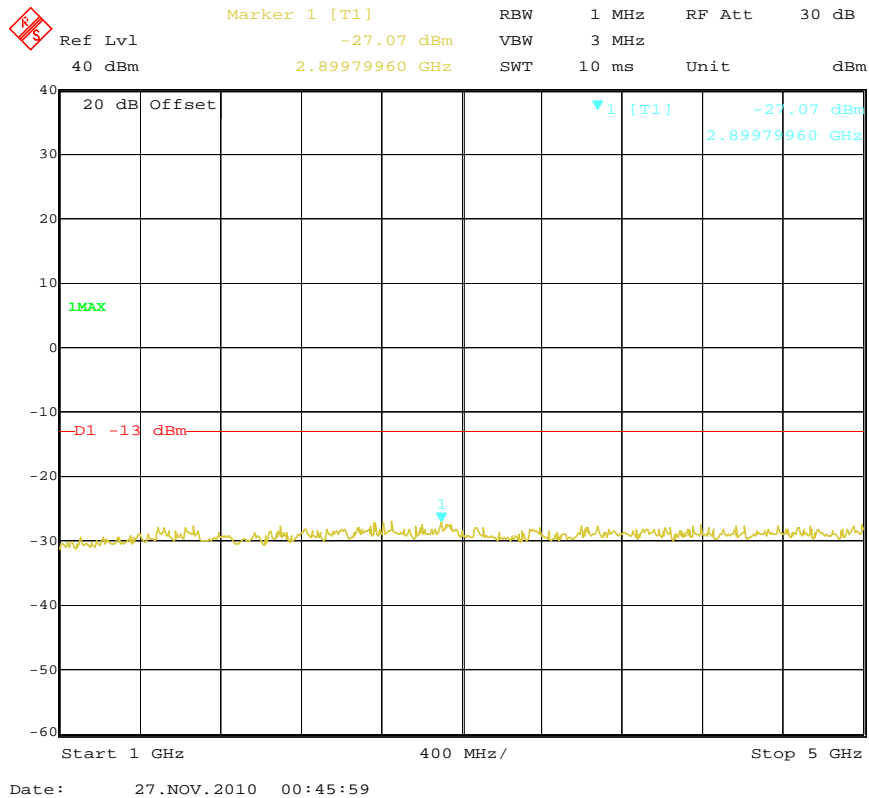
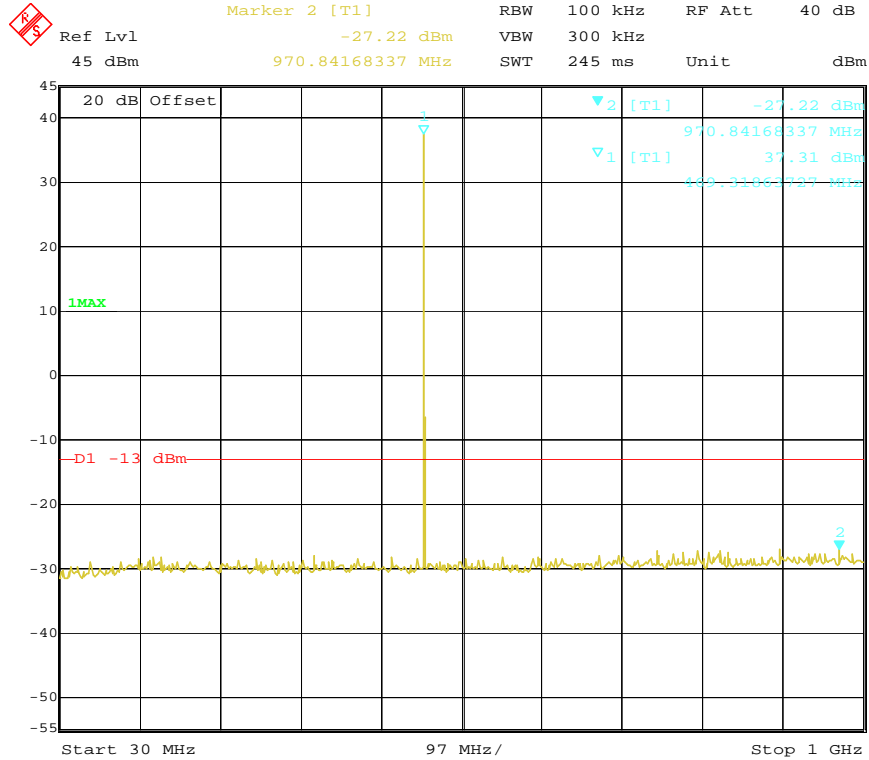

Modulation Type	Channel Separation	Test Channel	Test Frequency (MHz)	Maximum Conducted Spurious Emissions Below 1GHz		Maximum Conducted Spurious Emissions Above 1GHz		FCC Limit
				Frequency (MHz)	Datum (dBm)	Frequency (MHz)	Datum (dBm)	
FM	12.5KHz	Low	450.1250	986.39	-26.93	2963.93	-26.64	-20dBm
Test Results				Compliance				

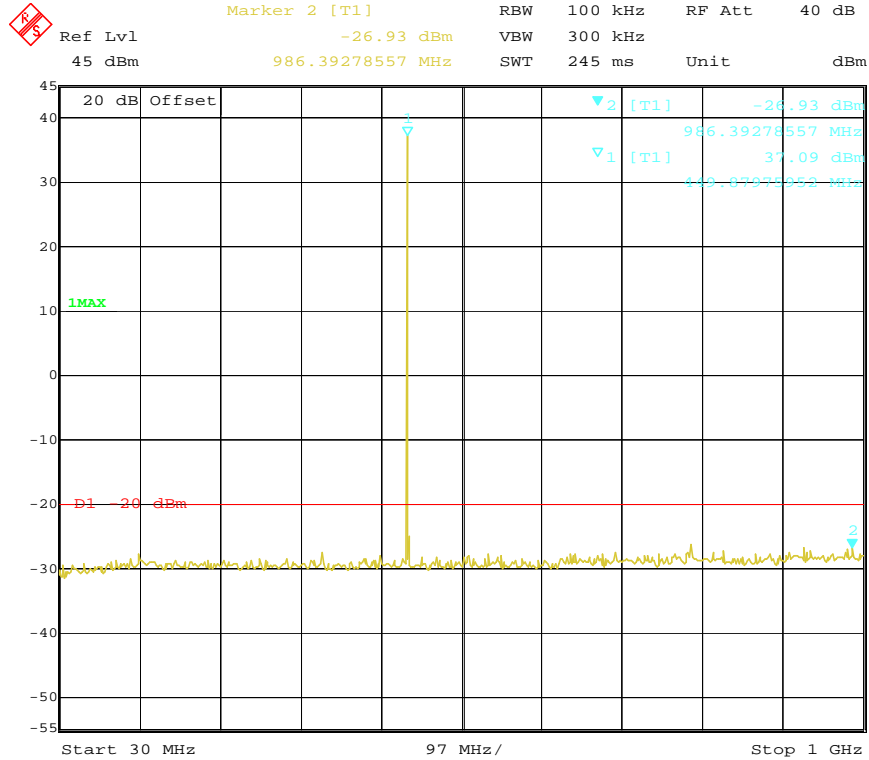

Date: 27.NOV.2010 00:50:03

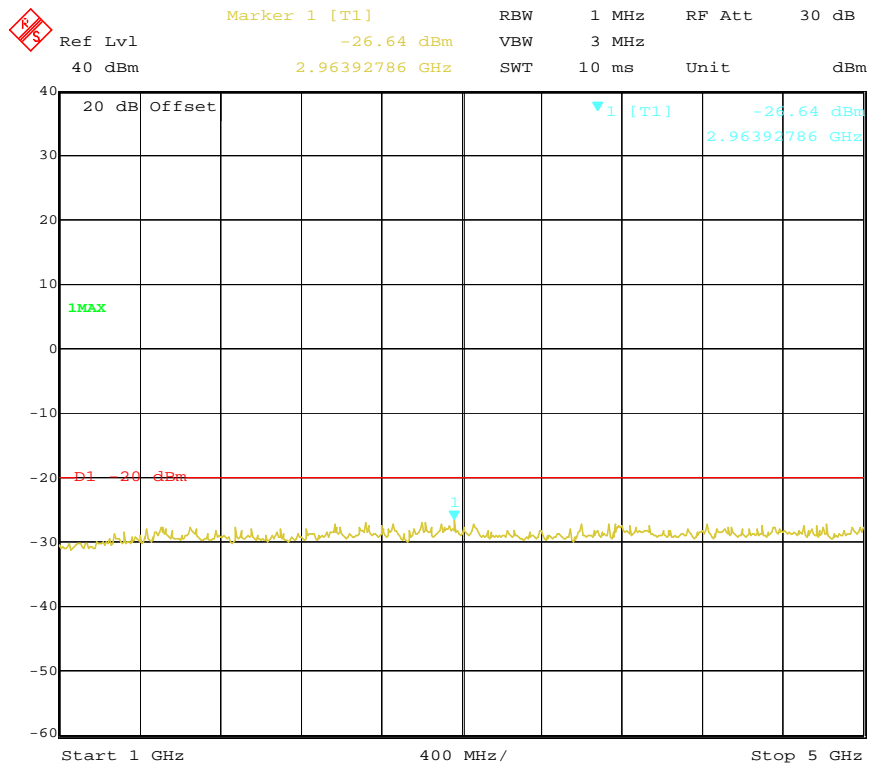

Date: 27.NOV.2010 00:50:37

Modulation Type	Channel Separation	Test Channel	Test Frequency (MHz)	Maximum Conducted Spurious Emissions Below 1GHz		Maximum Conducted Spurious Emissions Above 1GHz		FCC Limit
				Frequency (MHz)	Datum (dBm)	Frequency (MHz)	Datum (dBm)	
FM	12.5KHz	Middle	460.1250	792.00	-25.88	3452.91	-27.05	-20dBm
Test Results				Compliance				

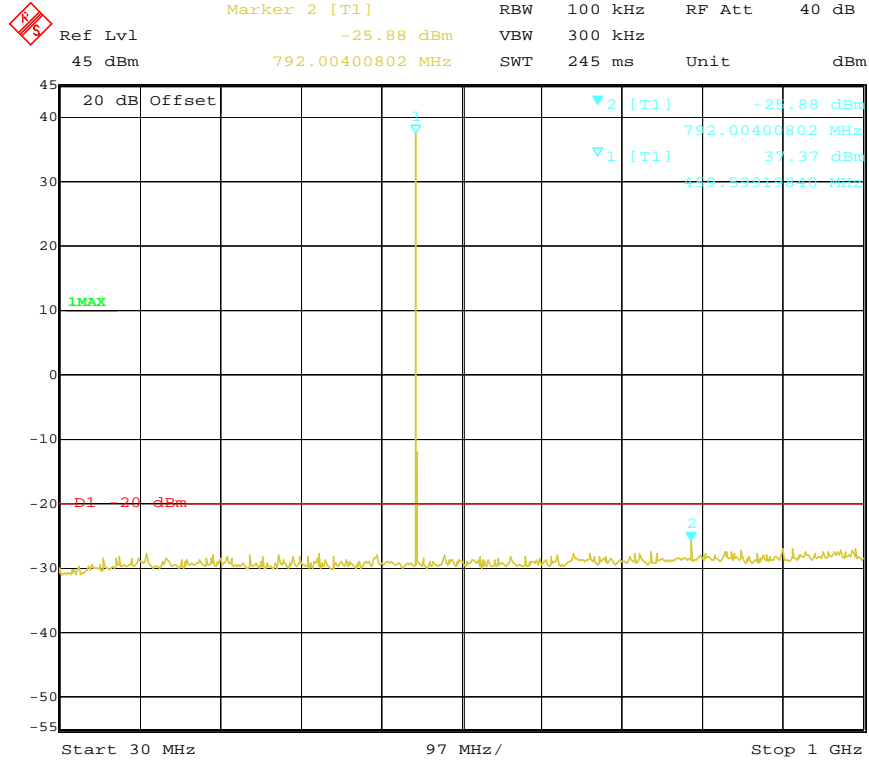

Date: 27.NOV.2010 00:52:00

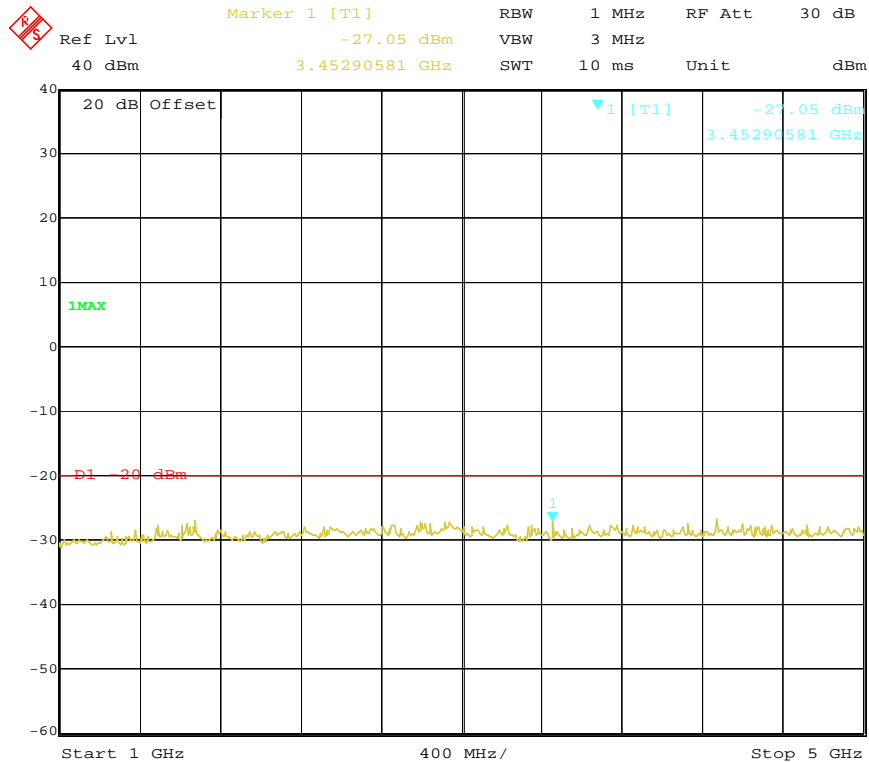

Date: 27.NOV.2010 00:51:09

Modulation Type	Channel SpARATION	Test Channel	Test Frequency (MHz)	Maximum Conducted Spurious Emissions Below 1GHz		Maximum Conducted Spurious Emissions Above 1GHz		FCC Limit
				Frequency (MHz)	Datum (dBm)	Frequency (MHz)	Datum (dBm)	
FM	12.5KHz	High	469.9875	968.90	-26.78	2386.77	-26.86	-20dBm
Test Results				Compliance				

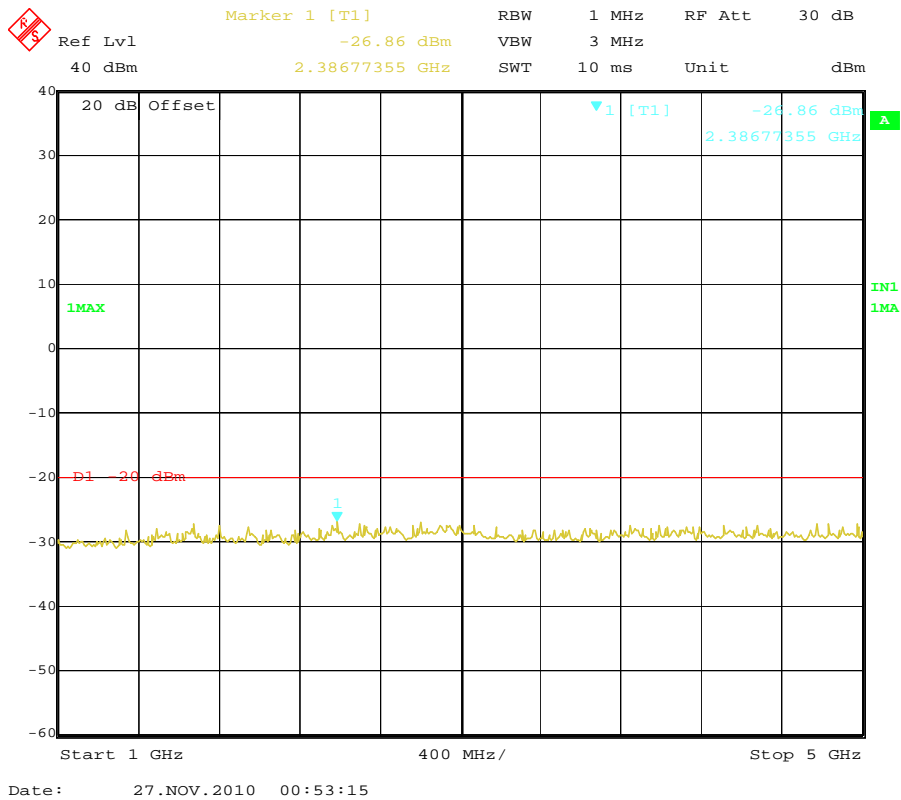
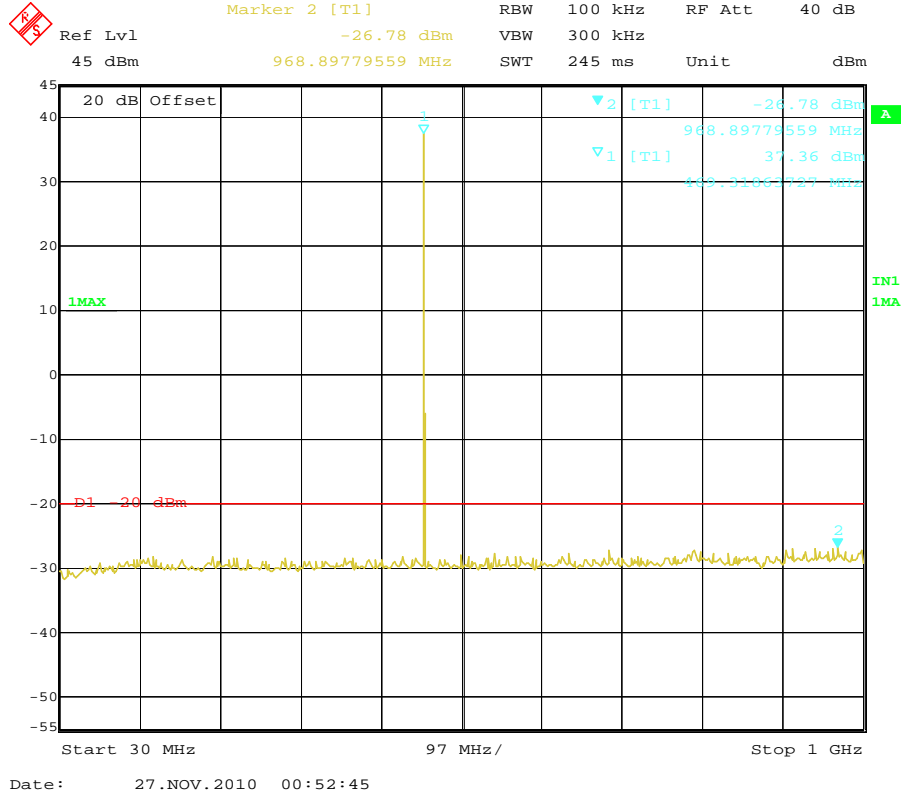

4.5. Modulation Characteristics

TEST APPLICABLE

According to CFR47 section 2.1047(a), for Voice Modulation Communication Equipment, the frequency response of the audio modulation circuit over a range of 100 to 5000Hz shall be measured.

TEST PROCEDURE

Modulation Limit

- 1 Configure the EUT as shown in figure 1, adjust the audio input for 60% of rated system deviation at 1 KHz using this level as a reference (0dB) and vary the input level from -20 to +20dB. Record the frequency deviation obtained as a function of the input level.
- 2 Repeat step 1 with input frequency changing to 300, 1004, and 2500Hz in sequence.

Audio Frequency Response

- 1 Configure the EUT as shown in figure 1.
- 2 Adjust the audio input for 20% of rated system deviation at 1 KHz using this level as a reference (0dB).
- 3 Vary the Audio frequency from 100 Hz to 10 KHz and record the frequency deviation.
- 4 Audio Frequency Response = $20 \log_{10} (\text{Deviation of test frequency} / \text{Deviation of 1 KHz reference})$.

TEST CONFIGURATION

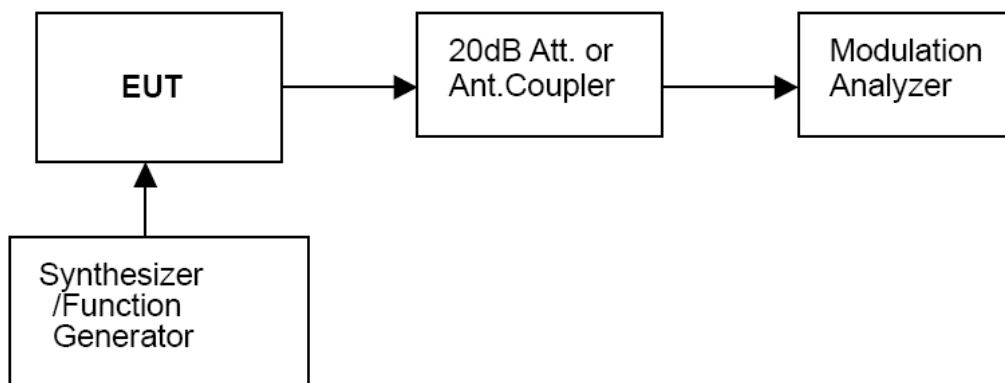

TEST RESULTS

Modulation Type: FM for FCC

25 KHz Channel Separation

Modulation Level(dB)	Peak Freq. Deviation At 300 Hz(KHz)	Peak Freq. Deviation At 1004 Hz(KHz)	Peak Freq. Deviation At 1500 Hz(KHz)	Peak Freq. Deviation At 2500 Hz(KHz)
-20	0.08	0.34	0.51	0.76
-15	0.11	0.56	0.88	1.34
-10	0.17	0.99	1.59	2.33
-5	0.27	1.78	2.82	3.52
0	0.45	3.06	3.83	3.61
+5	0.78	3.70	3.94	3.58
+10	1.18	3.88	3.94	3.58
+15	1.45	3.95	3.94	3.59
+20	1.66	4.03	3.94	3.59

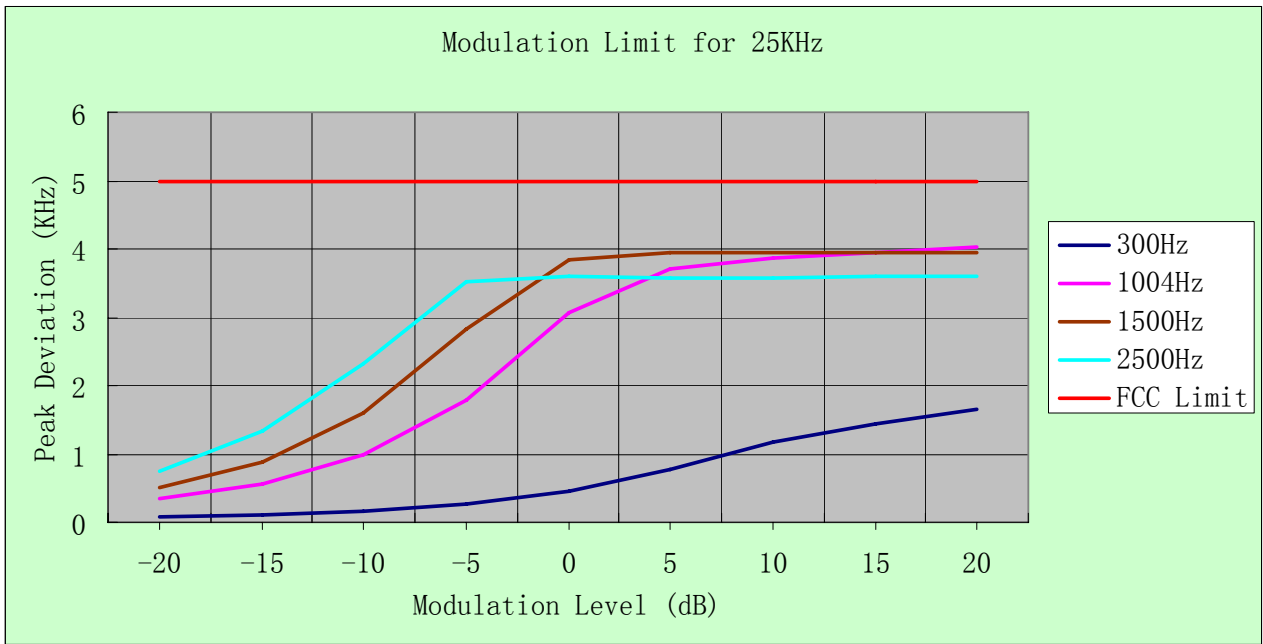

12.5 KHz Channel Separation

Modulation Level(dB)	Peak Freq. Deviation At 300 Hz(KHz)	Peak Freq. Deviation At 1004 H(KHz)	Peak Freq. Deviation At 1500 Hz(KHz)	Peak Freq. Deviation At 2500 Hz(KHz)
-20	0.06	0.19	0.26	0.38
-15	0.07	0.30	0.45	0.67
-10	0.11	0.51	0.80	1.21
-5	0.15	0.90	1.45	1.74
0	0.23	1.51	1.89	1.76
+5	0.40	1.81	1.94	1.76
+10	0.59	1.93	1.95	1.76
+15	0.71	1.99	1.96	1.76
+20	0.79	2.03	1.96	1.76

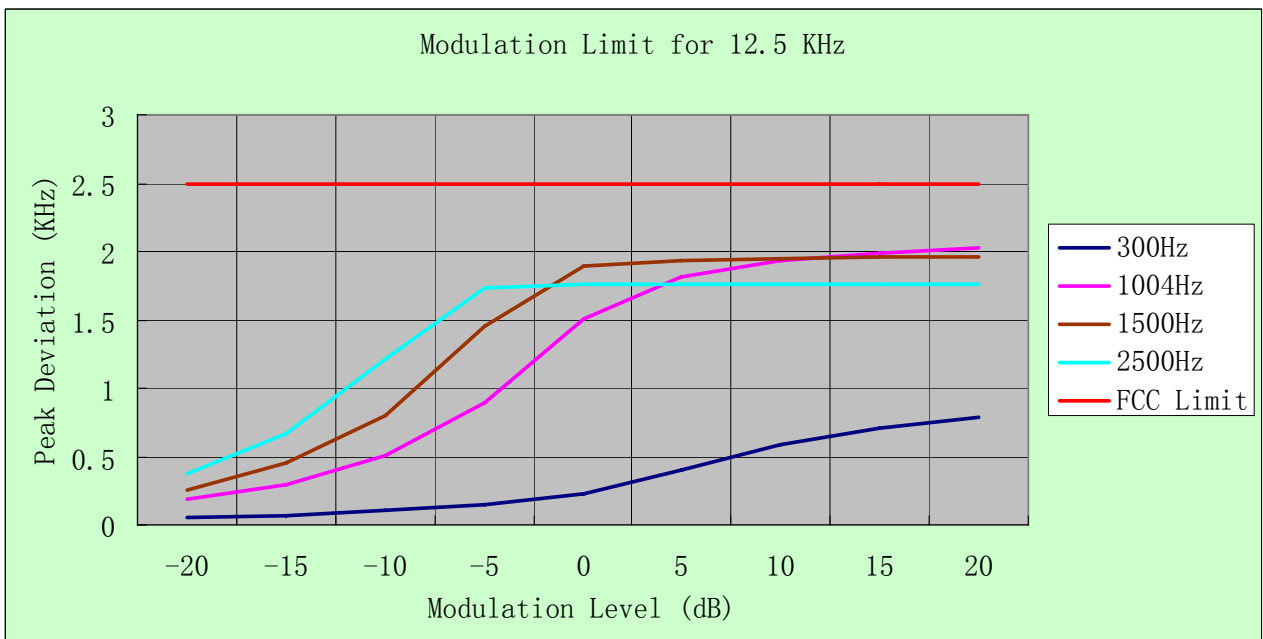

Modulation Type: FM for IC

25 KHz Channel Separation

Modulation Level(dB)	Peak Freq. Deviation At 300 Hz(KHz)	Peak Freq. Deviation At 1004 Hz(KHz)	Peak Freq. Deviation At 1500 Hz(KHz)	Peak Freq. Deviation At 2500 Hz(KHz)
-20	0.08	0.34	0.52	0.77
-15	0.11	0.58	0.93	1.40
-10	0.16	1.01	1.65	2.41
-5	0.27	1.81	2.89	3.50
0	0.44	3.06	3.82	3.57
+5	0.79	3.62	3.90	3.57
+10	1.21	3.79	3.91	3.57
+15	1.48	3.90	3.91	3.57
+20	1.72	3.97	3.91	3.57

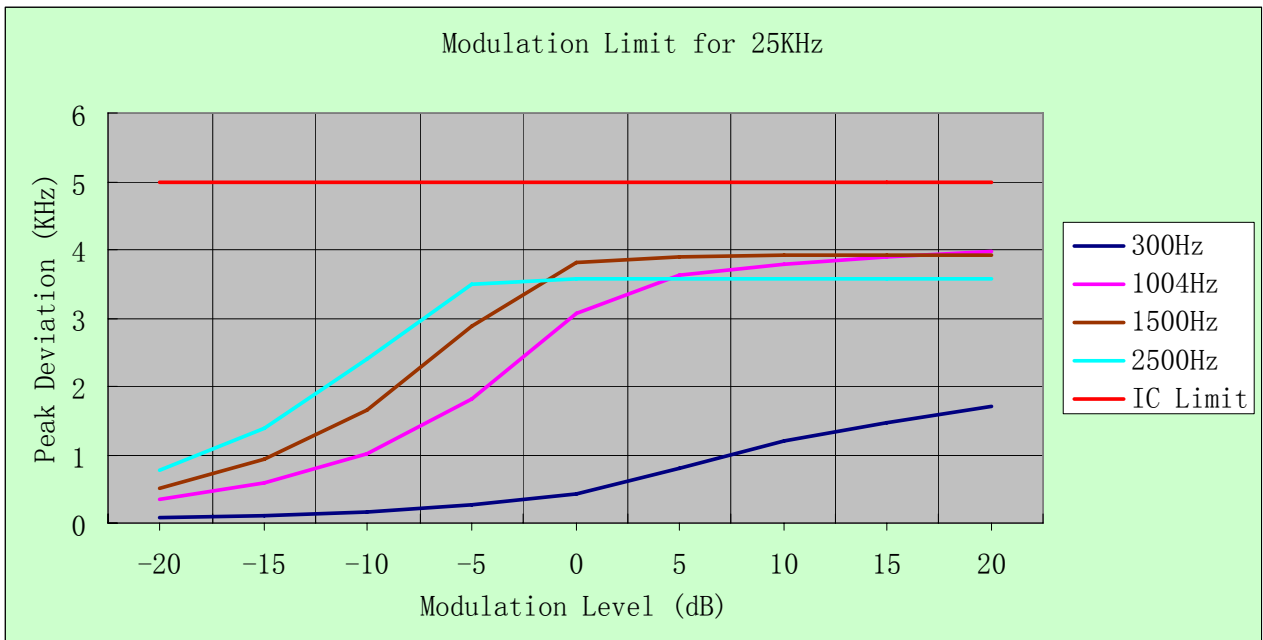

12.5 KHz Channel Separation

Modulation Level(dB)	Peak Freq. Deviation At 300 Hz(KHz)	Peak Freq. Deviation At 1004 H(KHz)	Peak Freq. Deviation At 1500 Hz(KHz)	Peak Freq. Deviation At 2500 Hz(KHz)
-20	0.06	0.18	0.28	0.39
-15	0.08	0.31	0.47	0.69
-10	0.11	0.51	0.80	1.24
-5	0.15	0.90	1.46	1.74
0	0.24	1.51	1.90	1.77
+5	0.41	1.81	1.94	1.77
+10	0.62	1.92	1.94	1.77
+15	0.73	1.98	1.95	1.77
+20	0.81	2.02	1.95	1.77

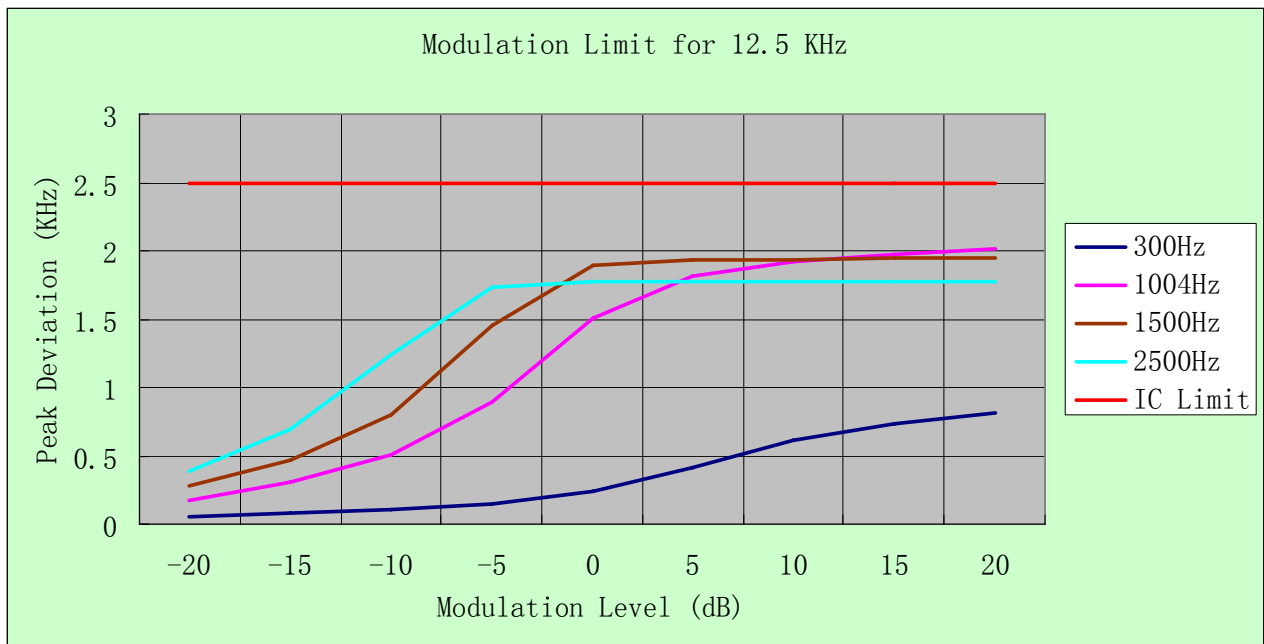

b). Audio Frequency Response:

Rule Part No.: Part 2.1407(a) (b)

Method of Measurement:

The audio frequency response was measured in accordance with TIA/EIA Specification 603 with no exception. A curve or equivalent data showing the frequency response of the audio modulating circuit over a range of 300-3000Hz shall be submitted and Audio Post Limiter Low Pass Filter Response from 3.0 KHz to 50KHz. However, the audio frequency response should test from 100Hz to 5.0 KHz according to FCC Part 90.

Modulation Type: FM

The audio frequency response curve is show below.and

Test Audio Level (1 KHz and 20% maximum deviation) for 25 KHz channel separation is 4.50mv and 4.40mv for 12.5 KHz channel separation for FCC while for 25 KHz channel separation is 4.60mv and 4.50mv for 12.5 KHz channel separation for IC.

Note:

- 1 Not applicable to new standard. However, tests are conducted under FCC's recommendation.
- 2 The Audio Frequency Response is identical for 12.5 KHz and 25 KHz channel separation

For FCC

For 25 KHz

Frequency (KHz)	Frequency Deviation (KHz)	1KHz Reference Deviation (KHz)	Audio Frequency Response (dB)
0.1	0.04	1.01	-28.05
0.2	0.07	1.01	-23.18
0.3	0.23	1.01	-12.85
0.4	0.32	1.01	-9.98
0.5	0.43	1.01	-7.42
0.6	0.54	1.01	-5.44
0.7	0.67	1.01	-3.56
0.8	0.78	1.01	-2.24
0.9	0.89	1.01	-1.10
1.0	1.01	1.01	0.00
1.2	1.25	1.01	1.85
1.4	1.49	1.01	3.38
1.6	1.74	1.01	4.72
1.8	1.93	1.01	5.62
2.0	2.10	1.01	6.36
2.2	2.24	1.01	6.92
2.4	2.33	1.01	7.26
2.6	2.38	1.01	7.44
2.7	2.38	1.01	7.44
2.8	2.37	1.01	7.41
3.0	2.33	1.01	7.26
3.5	0.06	1.01	-26.52
4.0	0.05	1.01	-26.11
4.5	0.04	1.01	-28.05
5.0	0.04	1.01	-28.05

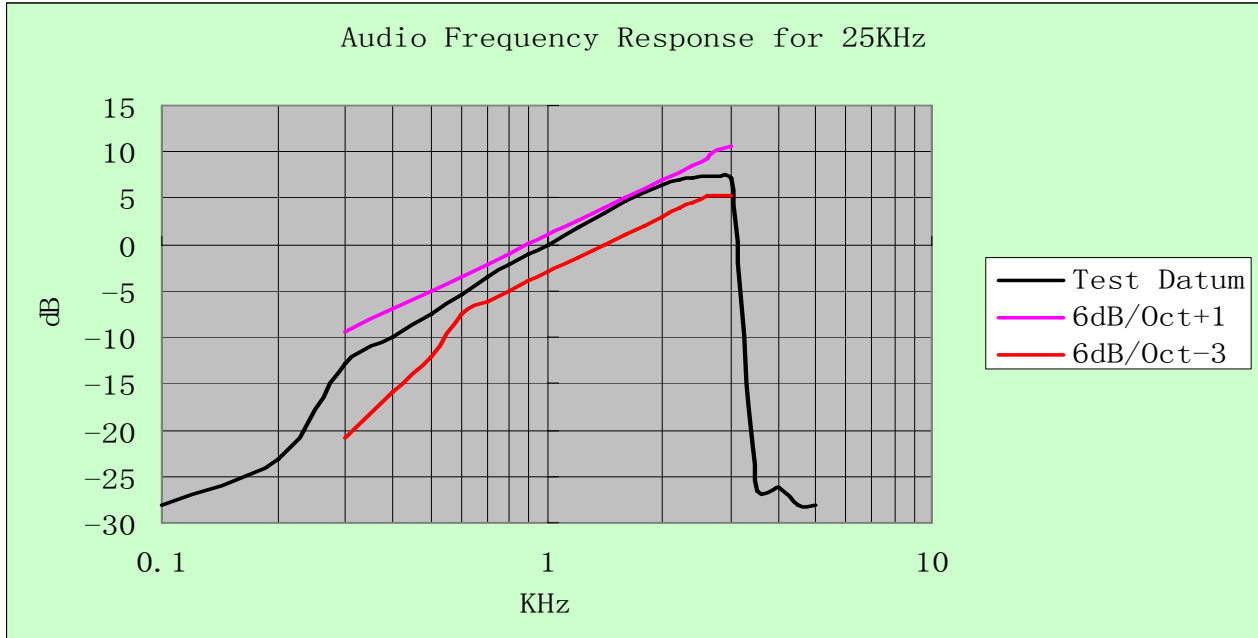

For 12.5 KHz

Frequency (KHz)	Frequency Deviation (KHz)	1KHz Referece Deviation (KHz)	Audio Frequency Response (dB)
0.1	0.03	0.51	-24.61
0.2	0.05	0.51	-20.17
0.3	0.13	0.51	-11.87
0.4	0.17	0.51	-9.54
0.5	0.22	0.51	-7.30
0.6	0.28	0.51	-5.21
0.7	0.34	0.51	-3.52
0.8	0.40	0.51	-2.11
0.9	0.47	0.51	-0.71
1.0	0.51	0.51	0.00
1.2	0.62	0.51	1.70
1.4	0.74	0.51	3.23
1.6	0.84	0.51	4.33
1.8	0.94	0.51	5.31
2.0	1.03	0.51	6.11
2.2	1.12	0.51	6.83
2.4	1.18	0.51	7.29
2.6	1.21	0.51	7.50
2.7	1.21	0.51	7.50
2.8	1.21	0.51	7.50
3.0	1.20	0.51	7.43
3.5	0.06	0.51	-18.59
4.0	0.05	0.51	-20.17
4.5	0.04	0.51	-22.11
5.0	0.04	0.51	-22.11

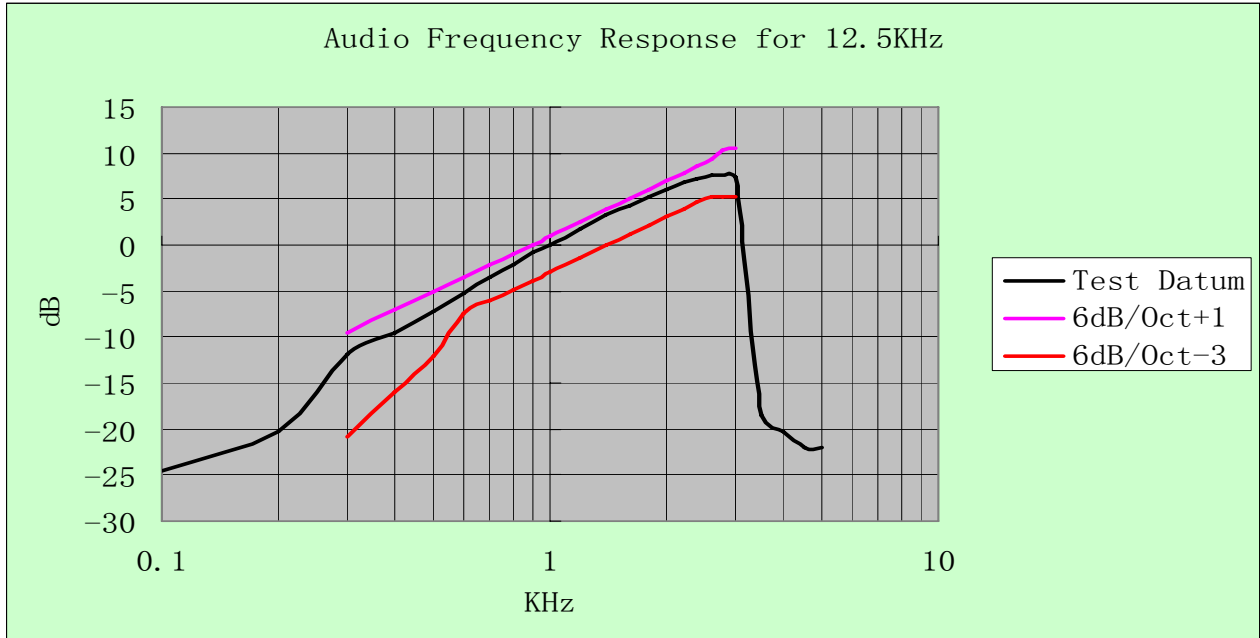

For IC

For 25 KHz

Frequency (KHz)	Frequency Deviation (KHz)	1KHz Reference Deviation (KHz)	Audio Frequency Response (dB)
0.1	0.04	0.99	-27.87
0.2	0.08	0.99	-21.85
0.3	0.16	0.99	-15.83
0.4	0.26	0.99	-11.61
0.5	0.38	0.99	-8.32
0.6	0.49	0.99	-6.11
0.7	0.62	0.99	-4.06
0.8	0.75	0.99	-2.41
0.9	0.87	0.99	-1.22
1.0	0.99	0.99	0.00
1.2	1.24	0.99	1.96
1.4	1.47	0.99	3.43
1.6	1.72	0.99	4.80
1.8	1.91	0.99	5.71
2.0	2.09	0.99	6.49
2.2	2.23	0.99	7.05
2.4	2.32	0.99	7.40
2.6	2.38	0.99	7.62
2.7	2.38	0.99	7.62
2.8	2.36	0.99	7.55
3.0	2.32	0.99	7.40
3.5	0.05	0.99	-25.93
4.0	0.04	0.99	-27.87
4.5	0.04	0.99	-27.87
5.0	0.04	0.99	-27.87

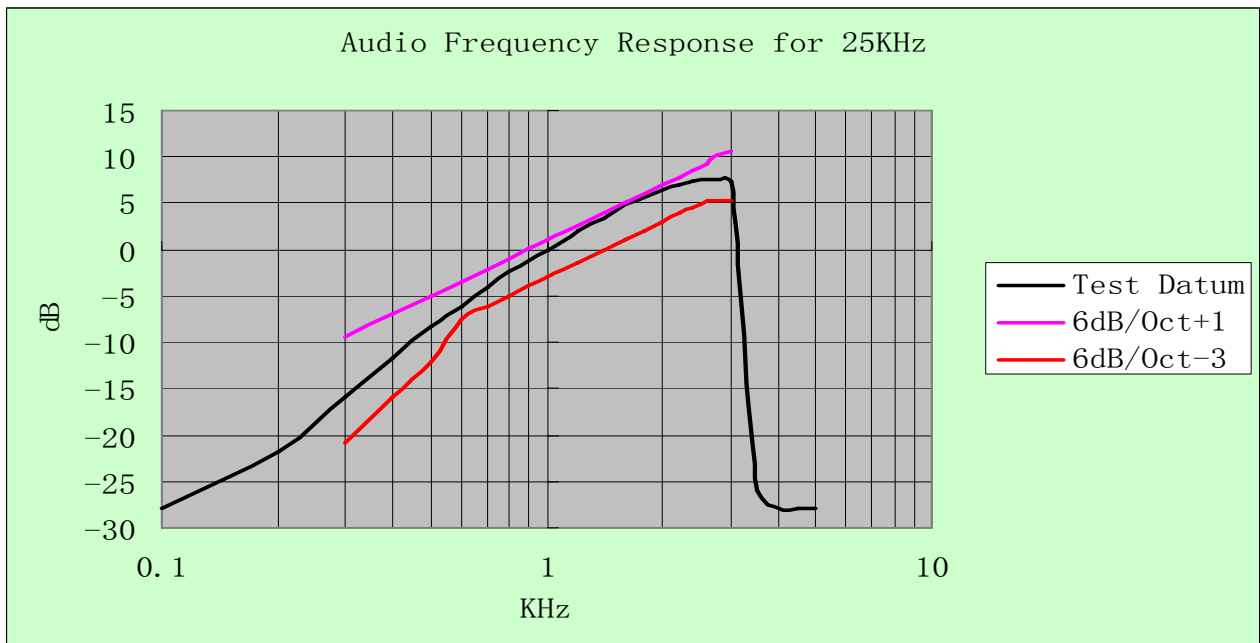

For 12.5 KHz

Frequency (KHz)	Frequency Deviation (KHz)	1KHz Refenerce Deviation (KHz)	Audio Frequency Response (dB)
0.1	0.04	0.49	-21.76
0.2	0.05	0.49	-19.82
0.3	0.09	0.49	-14.72
0.4	0.15	0.49	-10.28
0.5	0.21	0.49	-7.36
0.6	0.27	0.49	-5.18
0.7	0.32	0.49	-3.70
0.8	0.38	0.49	-2.21
0.9	0.44	0.49	-0.93
1.0	0.49	0.49	0.00
1.2	0.61	0.49	1.90
1.4	0.73	0.49	3.46
1.6	0.85	0.49	4.78
1.8	0.95	0.49	5.75
2.0	1.03	0.49	6.45
2.2	1.12	0.49	7.18
2.4	1.17	0.49	7.56
2.6	1.21	0.49	7.85
2.7	1.22	0.49	7.92
2.8	1.21	0.49	7.85
3.0	1.19	0.49	7.71
3.5	0.07	0.49	-16.90
4.0	0.05	0.49	-19.82
4.5	0.04	0.49	-21.76
5.0	0.04	0.49	-21.76

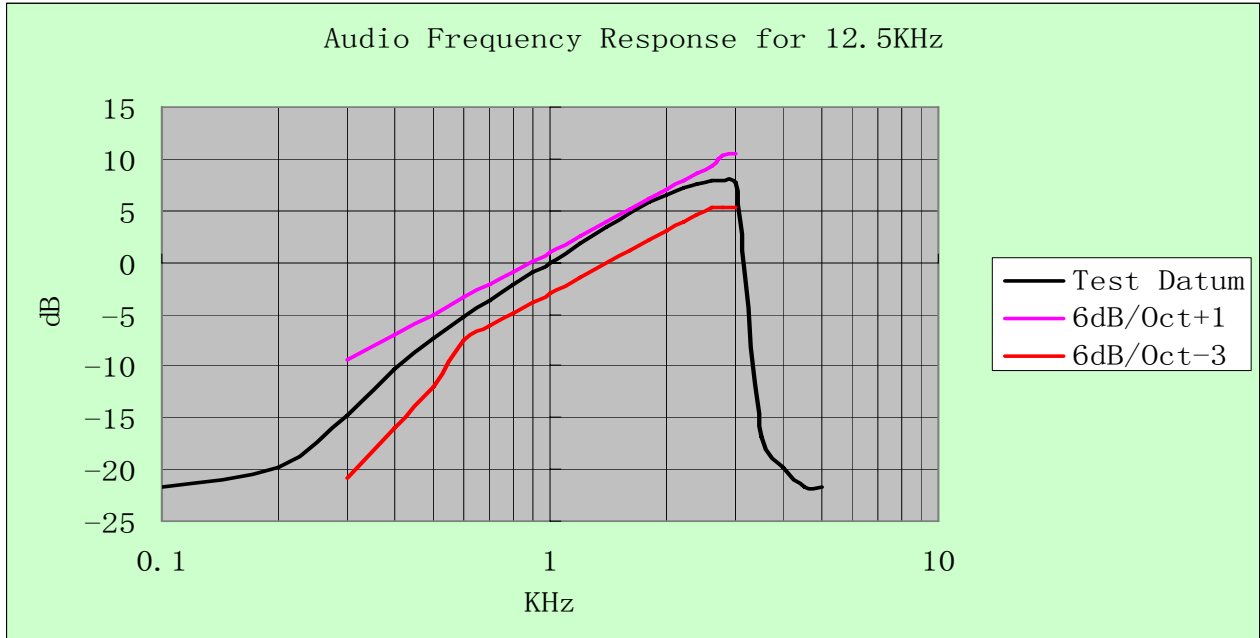

4.6. Frequency Stability

TEST APPLICABLE

- 1 According to FCC Part 2 Section 2.1055 (a) (1) and RSS-119 Section 5.3, the frequency stability shall be measured with variation of ambient temperature from -30°C to +60°C centigrade.
- 2 According to FCC Part 2 Section 2.1055 (a) (2) and RSS-119 Section 5.3, for battery powered equipment, the frequency stability shall be measured with reducing primary supply voltage to the battery operating end point, which is specified by the manufacture.
- 3 Vary primary supply voltage from 85 to 115 percent of the nominal value for other than hand carried battery equipment.
- 4 According to §90.213 and RSS-119 Section 5.3, the frequency stability limit is 2.5 ppm for 12.5KHz channel separation and 5 ppm for 25KHz channel separation.

TEST PROCEDURE

The EUT was set in the climate chamber and connected to an external DC power supply. The RF output was directly connected to Spectrum Analyzer ESI 26. The coupling loss of the additional cables was recorded and taken in account for all the measurements. After temperature stabilization (approx. 20 min for each stage), the frequency for the lower, the middle and the highest frequency range was recorded. For Frequency stability Vs. Voltage the EUT was connected to a DC power supply and the voltage was adjusted in the required ranges. The result was recorded.

TEST CONFIGURATION

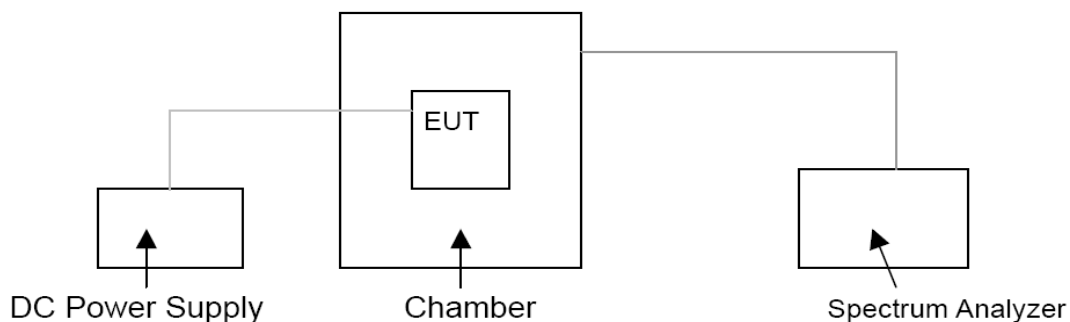

TEST LIMITS

According to 90.213, Transmitters used must have minimum frequency stability as specified in the following table.

Frequency Range (MHz)	Channel Bandwidth (KHz)	Frequency Tolerance (ppm)		
		Fixed and Base Stations	Mobile Stations	
			> 2 W	≤ 2 W
150-174 MHz	6.25	1.0	2.0	2.0
	12.5	2.5	5.0	5.0
	25	5.0	5.0	50.0*
421-512 MHz	6.25	0.5	1.0	1.0
	12.5	1.5	2.5	2.5
	25	2.5	5.0	5.0

- Stations operating in the 154.45 to 154.49 MHz or the 173.2 to 173.4 MHz bands must have a frequency stability of 5 ppm.
- Paging transmitters operating on paging-only frequencies must operate with frequency stability of 5 ppm in the 150-174 MHz band and 2.5 ppm in the 421-512 MHz band.

TEST RESULTS**For FCC**

Modulation Type	Channel Separation	Test conditions		Frequency error (ppm)		
		Voltage(V)	Temp(°C)	Low Channel	Middle Channel	High Channel
Analog/FM	25KHz	13.60	-30	-1.81	-1.90	-1.97
			-20	-1.70	-1.72	-1.88
			-10	-1.62	-1.55	-1.70
			0	-1.45	-1.47	-1.57
			10	-1.34	-1.33	-1.41
			20	-1.05	-1.08	-1.10
			30	-1.05	-1.08	-1.10
			40	-1.42	-1.30	-1.44
			50	-1.75	-1.78	-1.77
		11.56 (85% Rated)	20	-1.23	-1.23	-1.35
		15.64 (115% Rated)	20	-1.23	-1.23	-1.35
Limit			5.0 ppm			
Conclusion			Complies			

Modulation Type	Channel Separation	Test conditions		Frequency error (ppm)		
		Voltage(V)	Temp(°C)	Low Channel	Middle Channel	High Channel
Analog/FM	12.5KHz	13.60	-30	-1.81	-1.88	-1.92
			-20	-1.71	-1.69	-1.84
			-10	-1.67	-1.55	-1.70
			0	-1.45	-1.45	-1.57
			10	-1.33	-1.37	-1.46
			20	-1.23	-1.23	-1.35
			30	-1.23	-1.30	-1.35
			40	-1.42	-1.35	-1.44
			50	-1.69	-1.78	-1.82
		11.56 (85% Rated)	20	-1.23	-1.02	-1.35
		15.64 (115% Rated)	20	-1.23	-1.23	-1.35
Limit			2.5 ppm			
Conclusion			Complies			

For IC

Modulation Type	Channel Separation	Test conditions		Frequency error (ppm)		
		Voltage(V)	Temp(°C)	Low Channel	Middle Channel	High Channel
Analog/FM	25KHz	13.60	-30	-1.96	-1.92	-1.92
			-20	-1.88	-1.80	-1.78
			-10	-1.69	-1.69	-1.66
			0	-1.52	-1.55	-1.52
			10	-1.37	-1.47	-1.40
			20	-1.16	-1.32	-1.24
			30	-1.16	-1.32	-1.24
			40	-1.33	-1.57	-1.45
			50	-1.45	-1.80	-1.66
		11.56 (85% Rated)	20	-1.16	-1.38	-1.24
15.64 (115% Rated)	20	-1.10	-1.32	-1.24		
Limit			5.0 ppm			
Conclusion			Complies			

Modulation Type	Channel Separation	Test conditions		Frequency error (ppm)		
		Voltage(V)	Temp(°C)	Low Channel	Middle Channel	High Channel
Analog/FM	12.5KHz	13.60	-30	-1.98	-1.92	-1.89
			-20	-1.81	-1.85	-1.80
			-10	-1.67	-1.71	-1.67
			0	-1.55	-1.55	-1.52
			10	-1.40	-1.40	-1.44
			20	-1.25	-1.35	-1.26
			30	-1.25	-1.35	-1.26
			40	-1.44	-1.61	-1.44
			50	-1.45	-1.87	-1.67
		11.56 (85% Rated)	20	-1.16	-1.38	-1.26
15.64 (115% Rated)	20	-1.25	-1.38	-1.24		
Limit			2.5 ppm			
Conclusion			Complies			

4.7. Maximum Transmitter Power

TEST APPLICABLE

Per FCC «2.1046 and «90.205 and RSS-119 Section 5.4: Maximum ERP is dependent upon the station's antenna HAAT and required service area.

TEST PROCEDURE

Measurements shall be made to establish the radio frequency power delivered by the transmitter the standard output termination. The power output shall be monitored and recorded and no adjustment shall be made to the transmitter after the test has begun, except as noted below:

If the power output is adjustable, measurements shall be made for the highest and lowest power levels.

The EUT connect to the Receiver through 20 dB attenuator.

Measurement with Spectrum Analyzer ESI 26 conducted, external power supply with 13.60V stabilized supply voltage.

TEST CONFIGURATION

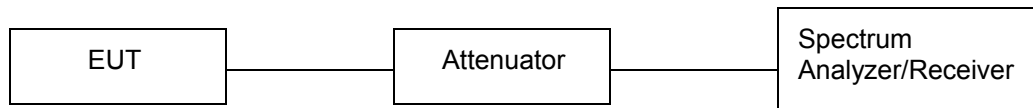

The EUT was directly connected to a RF Communication Test set by a 20 dB attenuator

TEST RESULTS

For FCC

Modulation Type	Channel Separation	Test Channel	Test Frequency	Maximum Transmitter Power at Rated High Power Level(dBm)	Maximum Transmitter Power at Rated Low Power Level(dBm)
Analog/FM	25KHz	Low Channel	438.1250 MHz	43.11	36.94
		Middle Channel	464.1250 MHz	43.50	37.50
		High Channel	489.9875 MHz	43.38	37.26
	12.5KHz	Low Channel	438.1250 MHz	43.11	36.98
		Middle Channel	464.1250 MHz	43.52	37.45
		High Channel	489.9875 MHz	43.33	37.34
Limit	The limit is dependent upon the station's antenna HAAT and required service area.				
Test Results	Complicance				

For IC

Modulation Type	Channel Separation	Test Channel	Test Frequency	Maximum Transmitter Power at Rated High Power Level(dBm)	Maximum Transmitter Power at Rated Low Power Level(dBm)
Analog/FM	25KHz	Low Channel	450.1250 MHz	43.35	37.19
		Middle Channel	460.1250 MHz	43.50	37.42
		High Channel	469.9875 MHz	43.51	37.39
	12.5KHz	Low Channel	450.1250 MHz	43.34	37.18
		Middle Channel	460.1250 MHz	43.51	37.44
		High Channel	469.9875 MHz	43.53	37.45
Limit		The output power shall be within ± 1.0 dB of the manufacturer's rated power.			
Test Results		Complicance			

Plots of Maximum Transmitter Power Measurement

For FCC

Modulation Type	Channel Separation	Freq.(MHz)	Rated Power (Watt)	Measurement (dBm)	FCC Limit	Results
FM	25 KHz	438.1250	25	43.11	Varies	Complicance

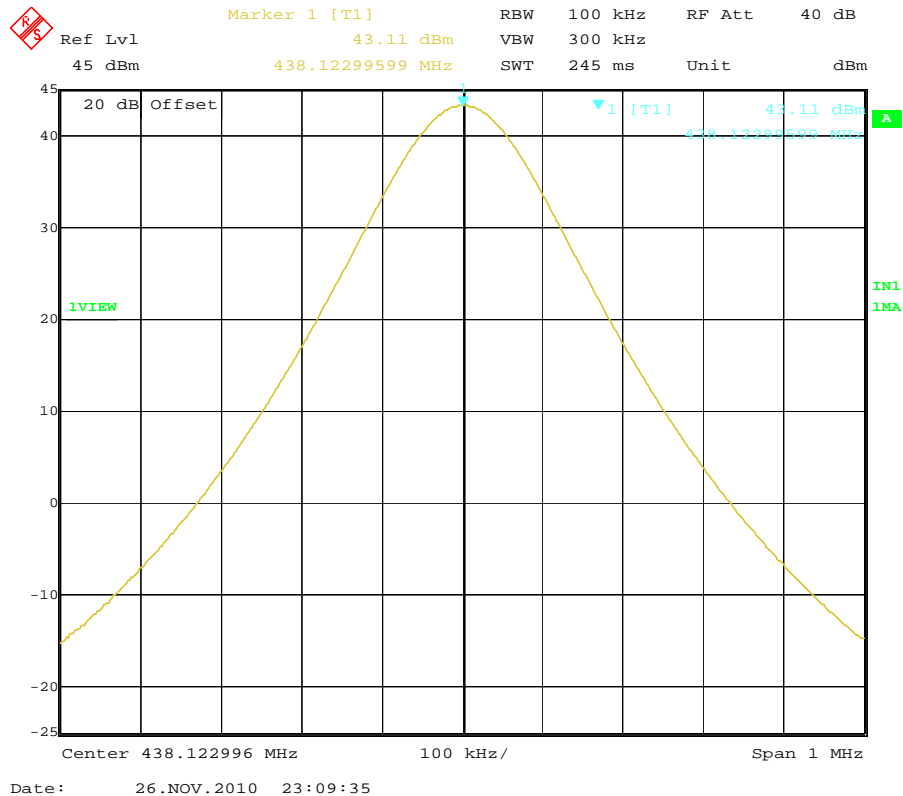

Modulation Type	Channel Separation	Freq.(MHz)	Rated Power (Watt)	Measurement (dBm)	FCC Limit	Results
FM	25 KHz	464.1250	25	43.50	Varies	Complicance

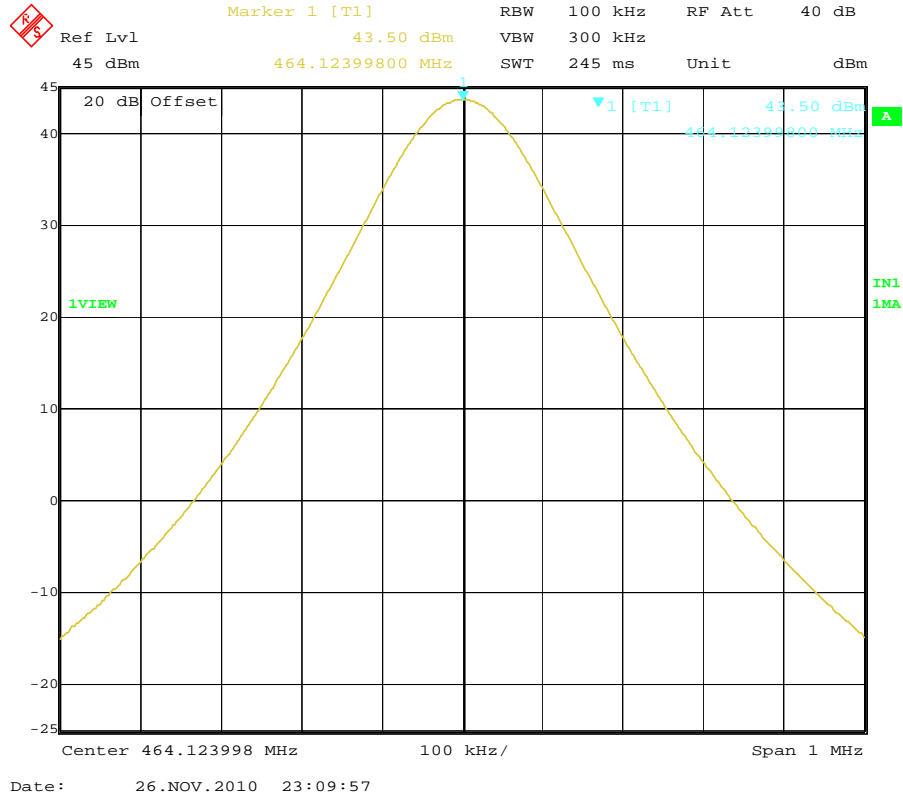

Modulation Type	Channel Separation	Freq.(MHz)	Rated Power (Watt)	Measurement (dBm)	FCC Limit	Results
FM	25 KHz	489.9875	25	43.38	Varies	Complicance

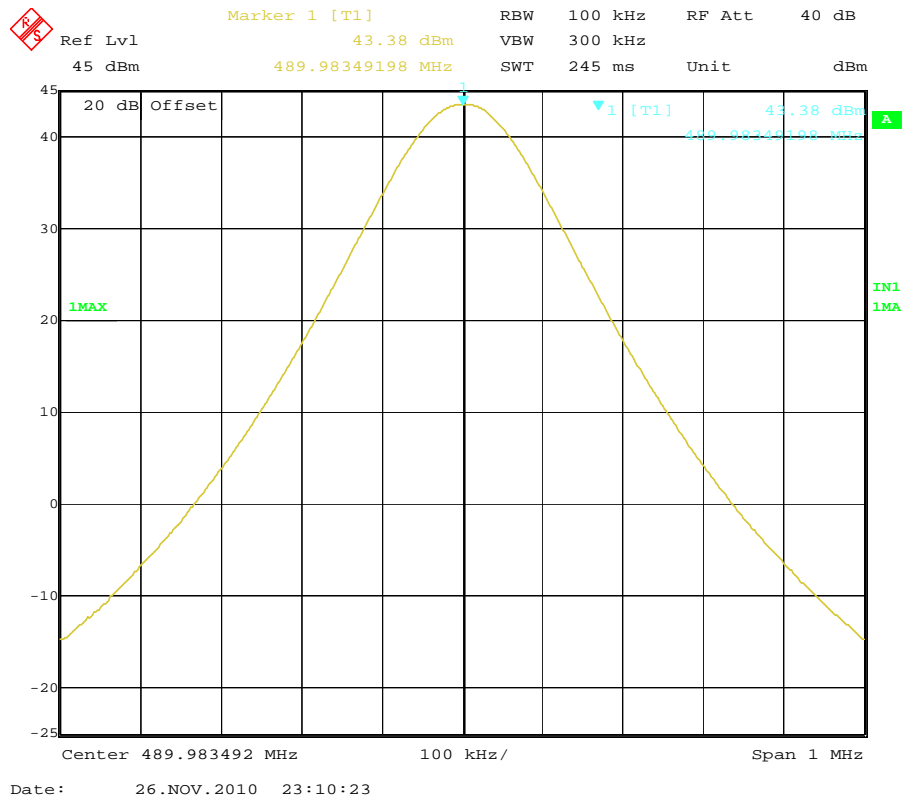

Modulation Type	Channel Separation	Freq.(MHz)	Rated Power (Watt)	Measurement (dBm)	FCC Limit	Results
FM	12.5 KHz	438.1250	25	43.11	Varies	Complicance

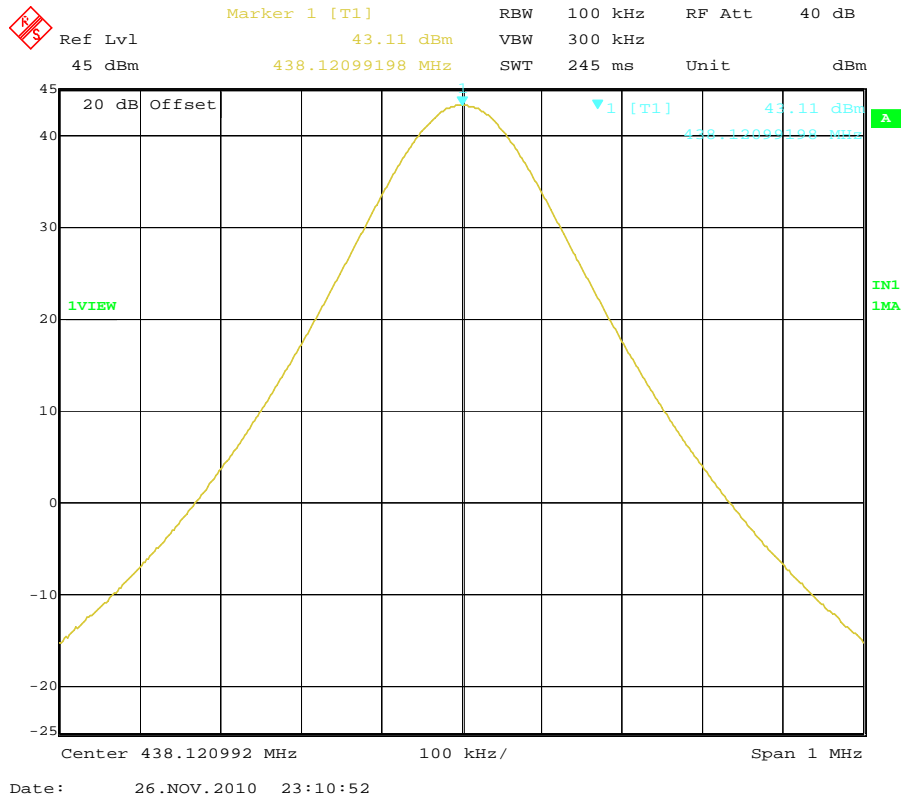

Modulation Type	Channel Separation	Freq.(MHz)	Rated Power (Watt)	Measurement (dBm)	FCC Limit	Results
FM	12.5 KHz	464.1250	25	43.52	Varies	Complicance

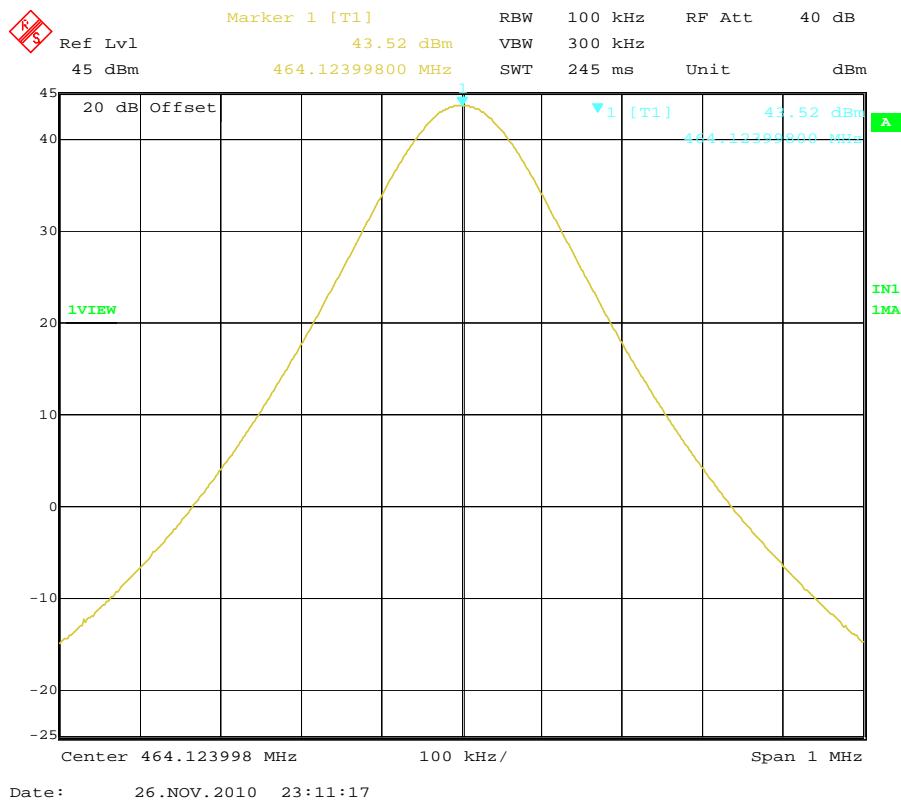

Modulation Type	Channel Separation	Freq.(MHz)	Rated Power (Watt)	Measurement (dBm)	FCC Limit	Results
FM	12.5 KHz	489.9875	25	43.33	Varies	Complicance

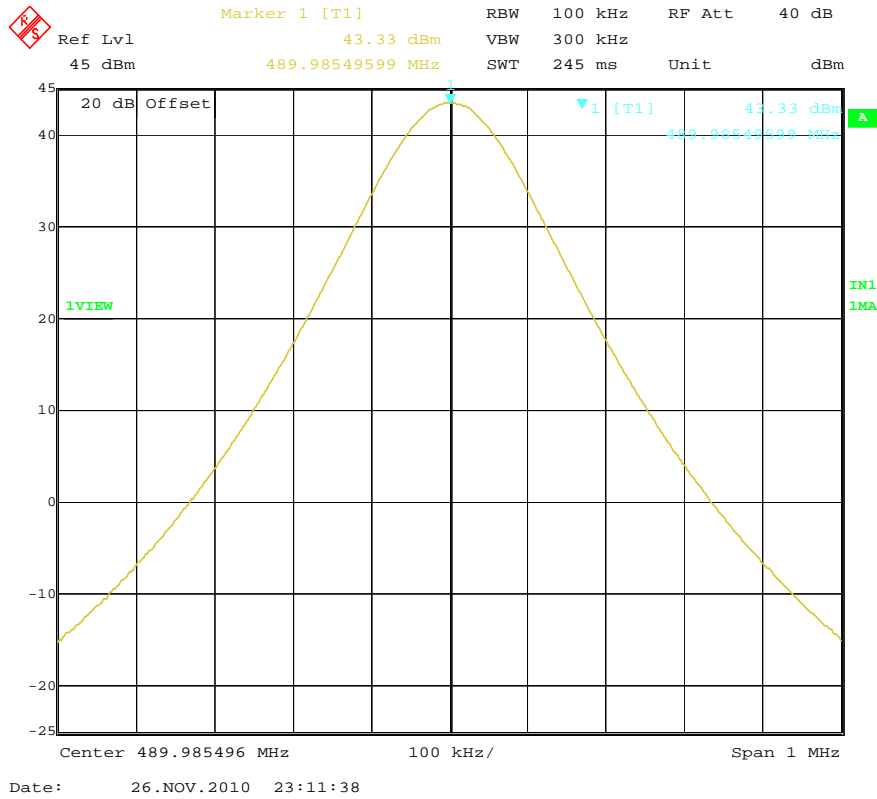

Modulation Type	Channel Separation	Freq.(MHz)	Rated Power (Watt)	Measurement (dBm)	FCC Limit	Results
FM	25 KHz	438.1250	5	36.94	Varies	Complicance

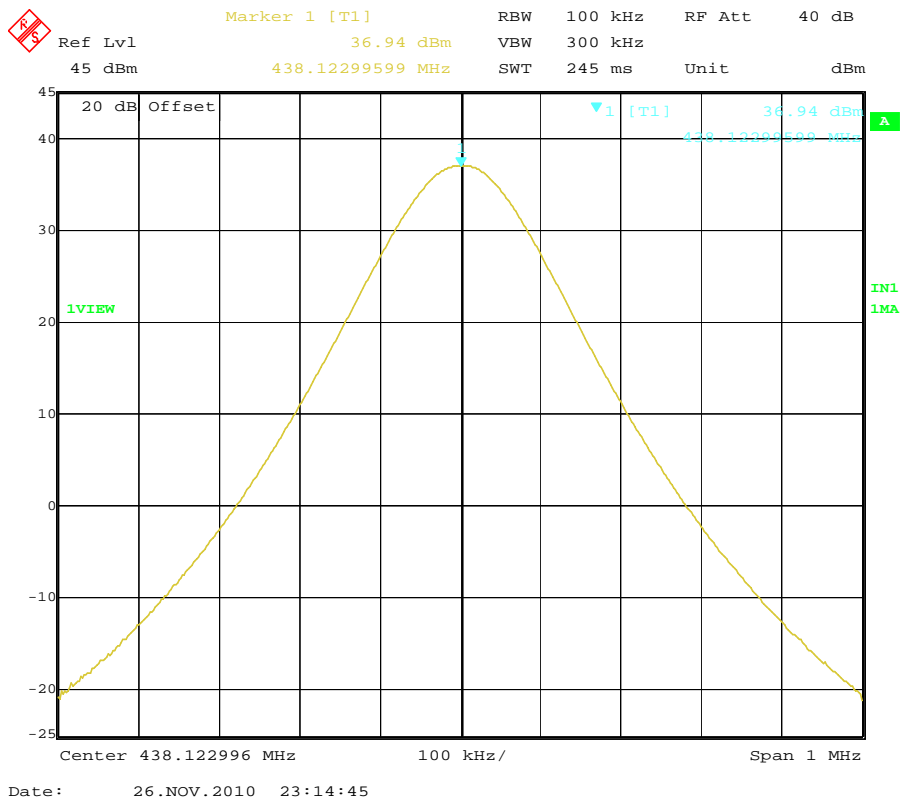

Modulation Type	Channel Separation	Freq.(MHz)	Rated Power (Watt)	Measurement (dBm)	FCC Limit	Results
FM	25 KHz	464.1250	5	37.50	Varies	Complicance

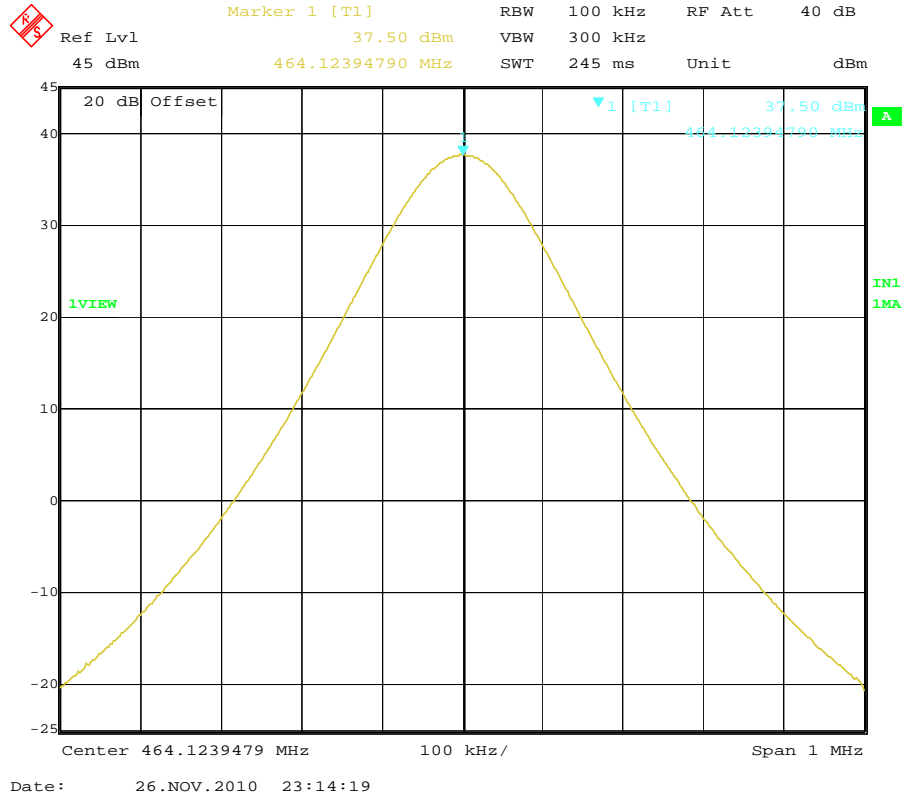

Modulation Type	Channel Separation	Freq.(MHz)	Rated Power (Watt)	Measurement (dBm)	FCC Limit	Results
FM	25 KHz	489.9875	5	37.26	Varies	Complicance

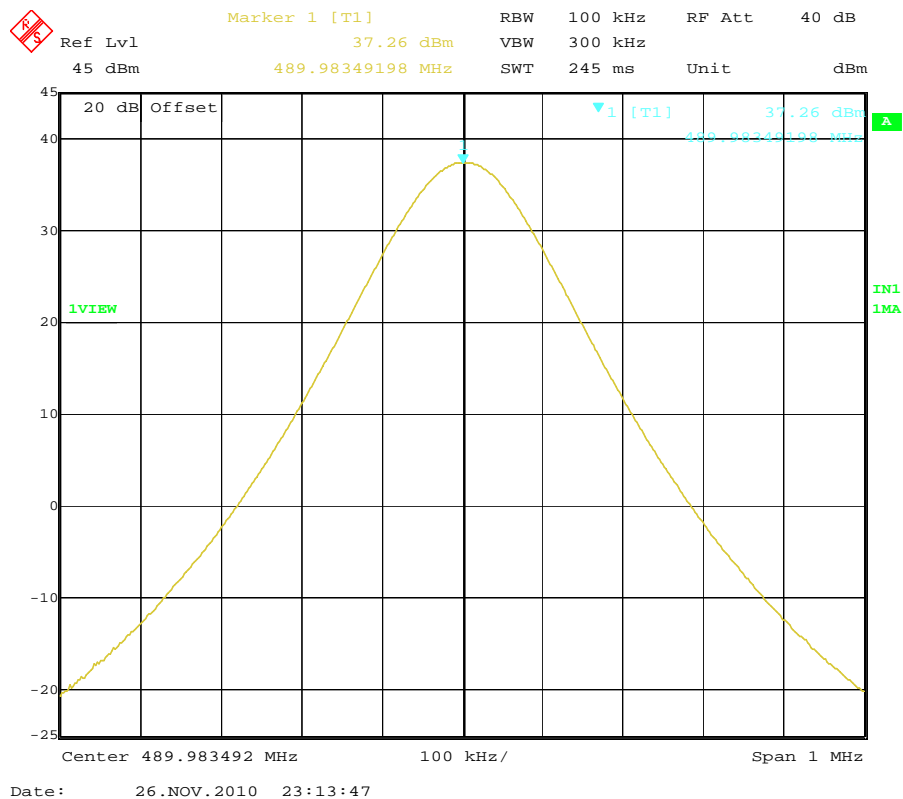

Modulation Type	Channel Separation	Freq.(MHz)	Rated Power (Watt)	Measurement (dBm)	FCC Limit	Results
FM	12.5 KHz	438.1250	5	36.98	Varies	Complicance

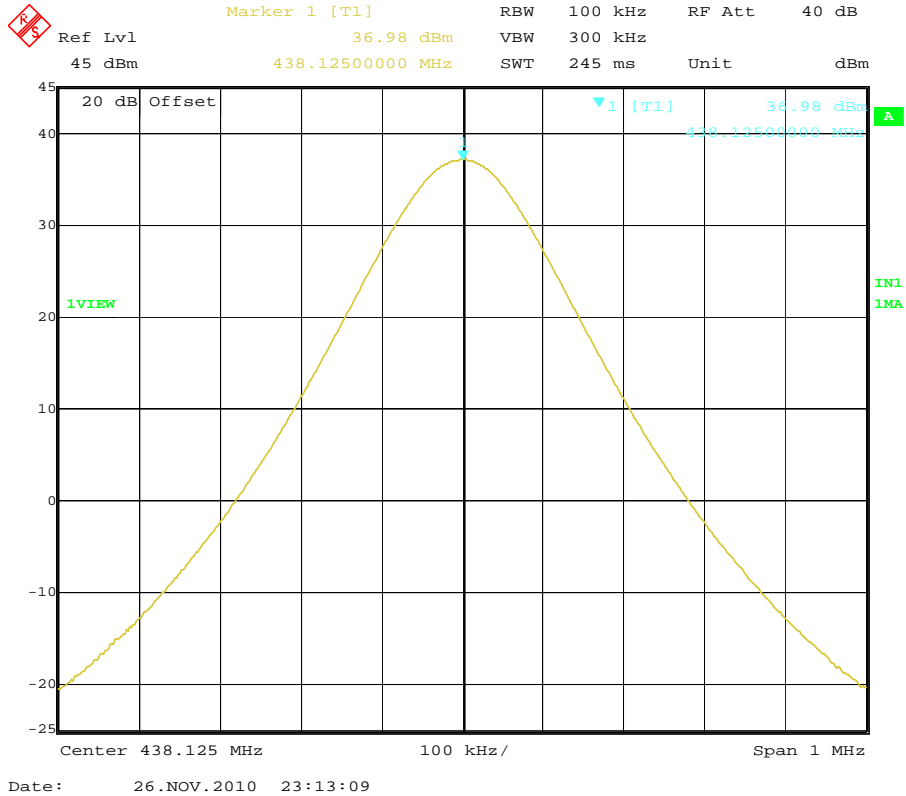

Modulation Type	Channel Separation	Freq.(MHz)	Rated Power (Watt)	Measurement (dBm)	FCC Limit	Results
FM	12.5 KHz	464.1250	5	37.45	Varies	Complicance

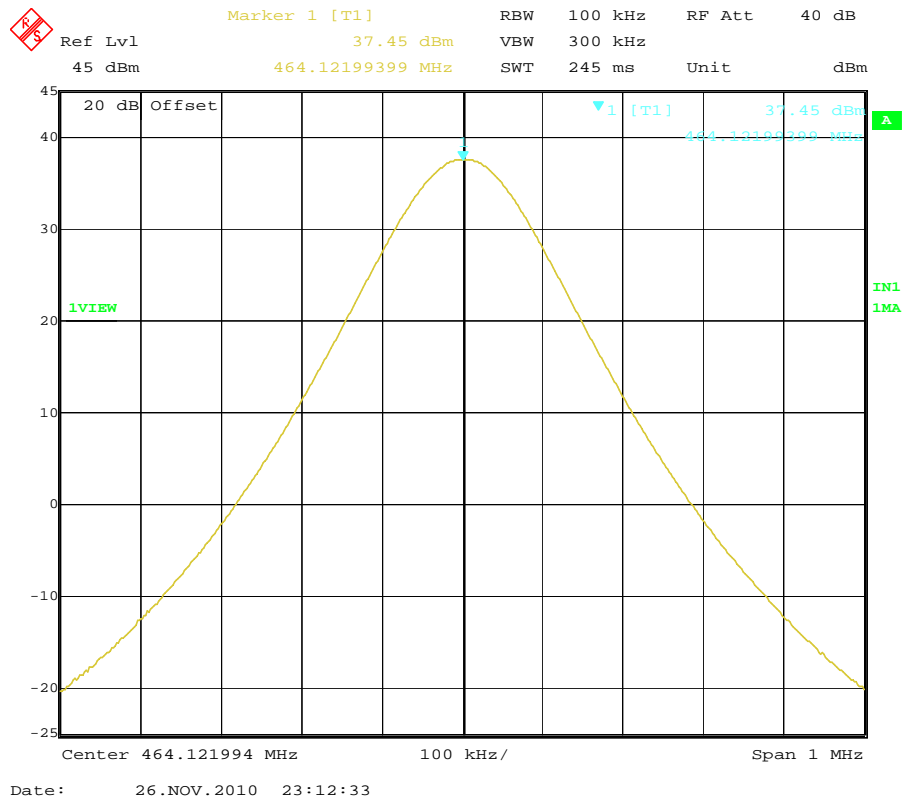

Modulation Type	Channel Separation	Freq.(MHz)	Rated Power (Watt)	Measurement (dBm)	FCC Limit	Results
FM	12.5 KHz	489.9875	5	37.34	Varies	Complicance

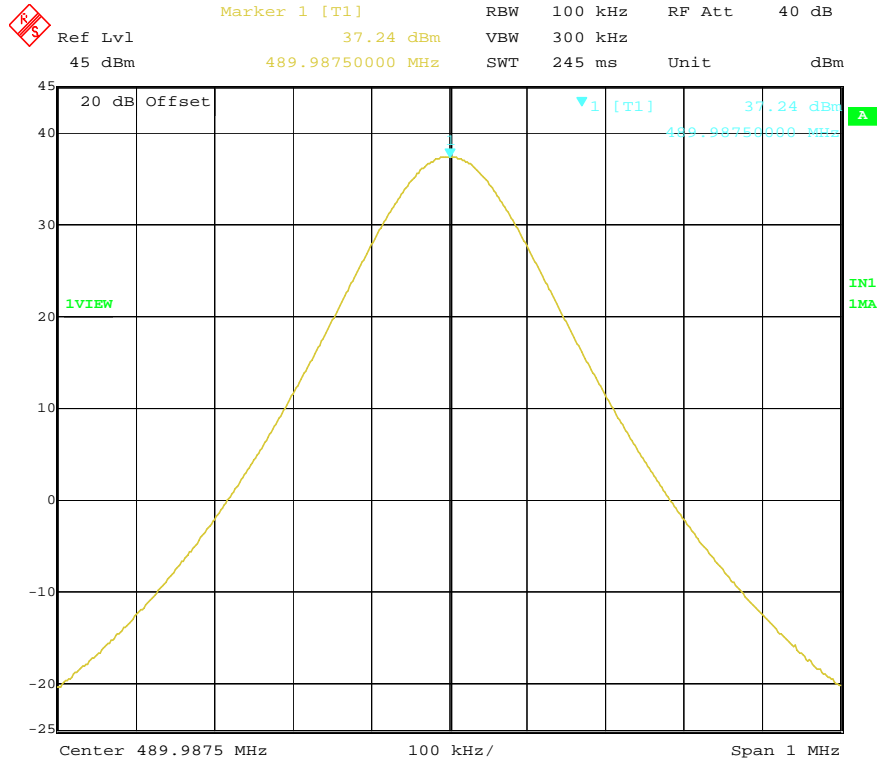

Date: 26.NOV.2010 23:12:02

For IC

Modulation Type	Channel Separation	Freq.(MHz)	Rated Power (Watt)	Measurement (dBm)	IC Limit (dBm)	Results
FM	25 KHz	450.1250	25	43.35	43.98 ± 1	Complicance

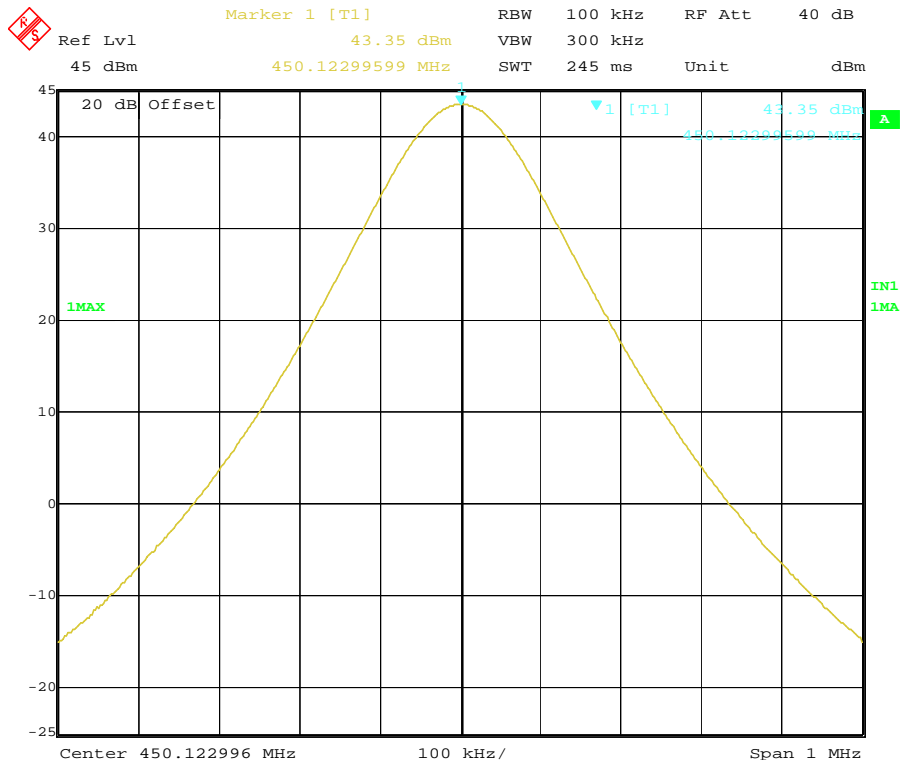

Date: 26.NOV.2010 23:01:14

Modulation Type	Channel Separation	Freq.(MHz)	Rated Power (Watt)	Measurement (dBm)	IC Limit (dBm)	Results
FM	25 KHz	460.1250	25	43.50	43.98 ± 1	Complicance

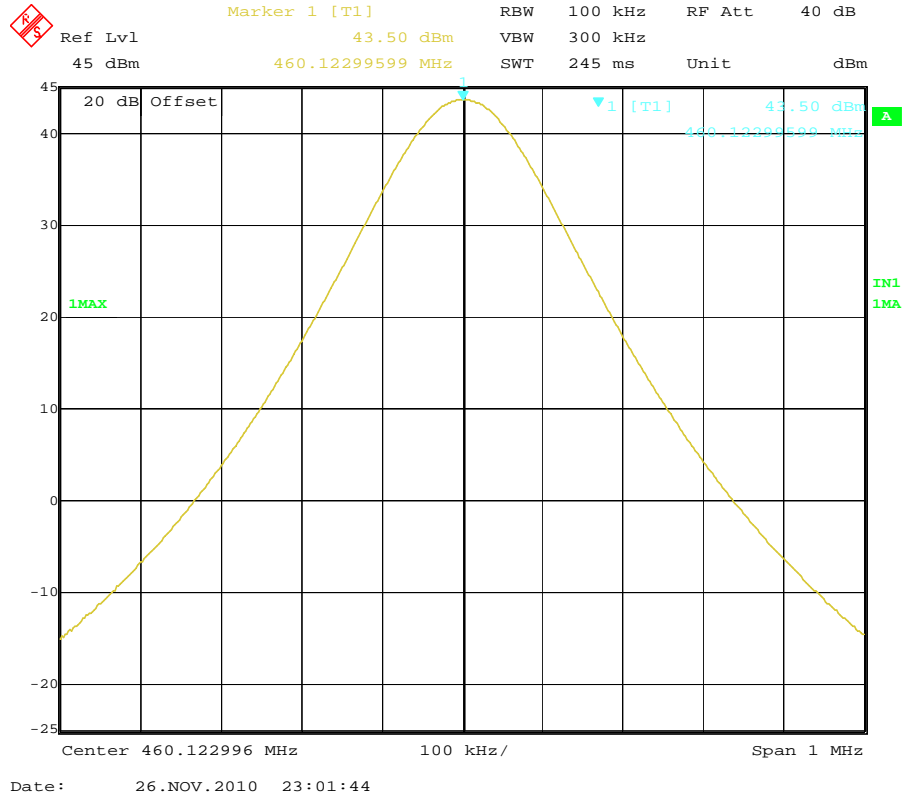

Modulation Type	Channel Separation	Freq.(MHz)	Rated Power (Watt)	Measurement (dBm)	IC Limit (dBm)	Results
FM	25 KHz	469.9875	25	43.51	43.98 ± 1	Complicance

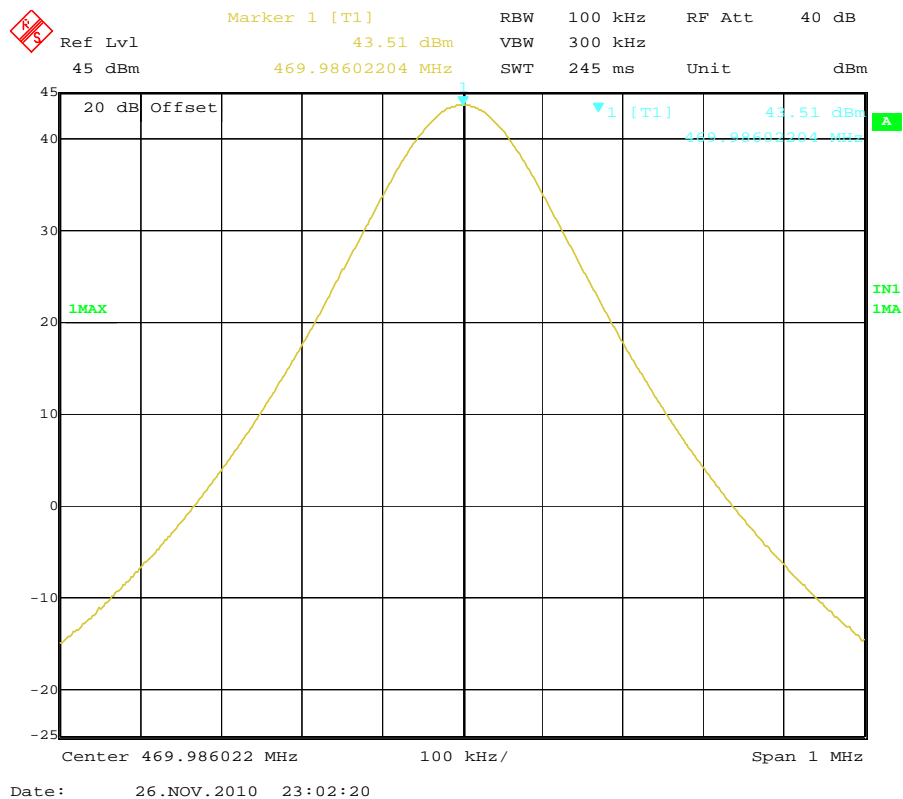

Modulation Type	Channel Separation	Freq.(MHz)	Rated Power (Watt)	Measurement (dBm)	IC Limit (dBm)	Results
FM	12.5 KHz	450.1250	25	43.34	43.98 ± 1	Complicance

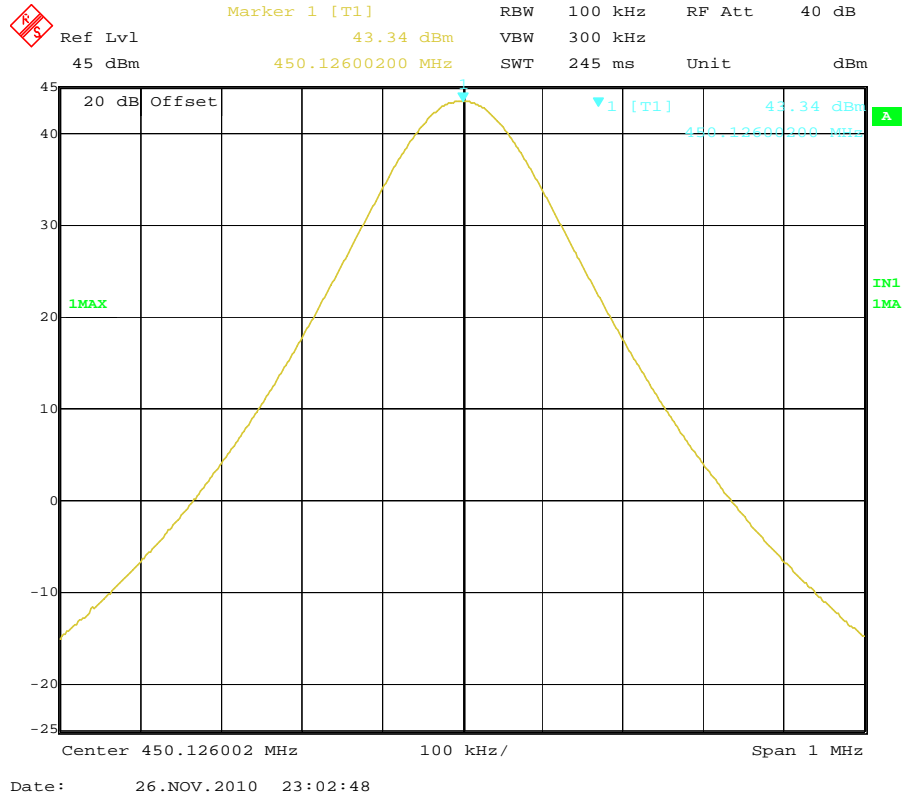

Modulation Type	Channel Separation	Freq.(MHz)	Rated Power (Watt)	Measurement (dBm)	IC Limit (dBm)	Results
FM	12.5 KHz	460.1250	25	43.51	43.98 ± 1	Complicance

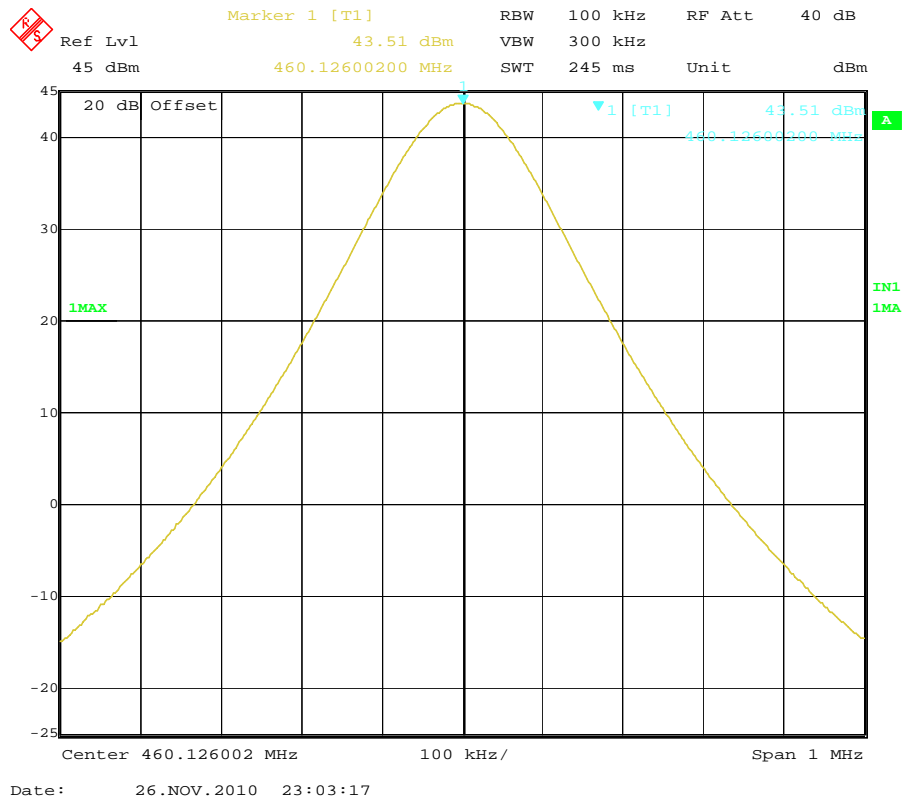

Modulation Type	Channel Separation	Freq.(MHz)	Rated Power (Watt)	Measurement (dBm)	IC Limit (dBm)	Results
FM	12.5 KHz	469.9875	25	43.53	43.98 ± 1	Complicance

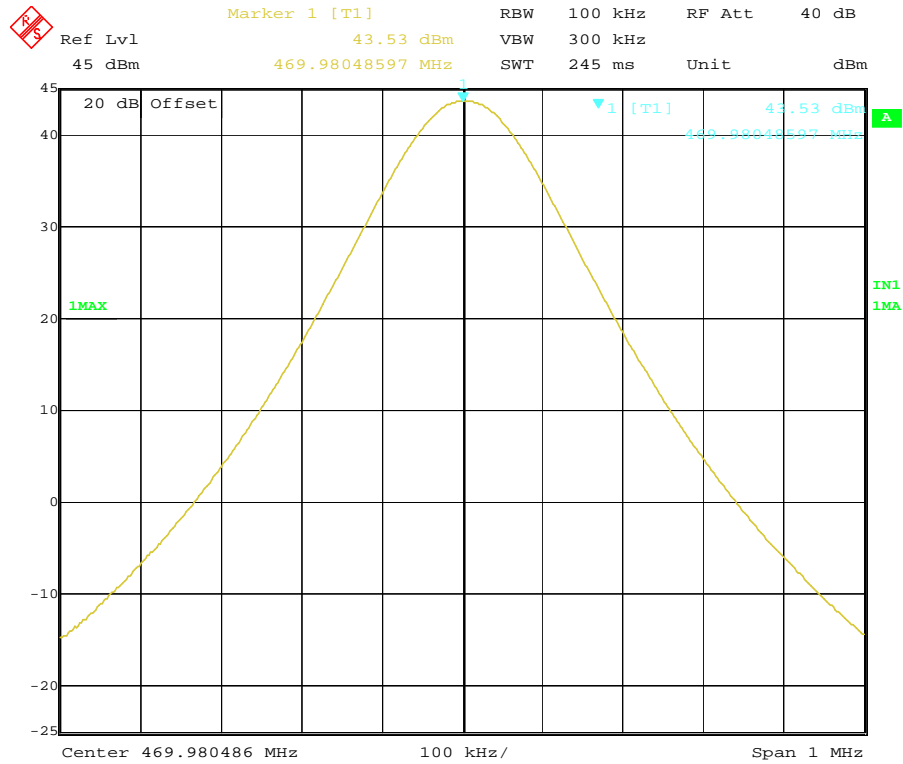

Date: 26.NOV.2010 23:03:55

Modulation Type	Channel Separation	Freq.(MHz)	Rated Power (Watt)	Measurement (dBm)	IC Limit (dBm)	Results
FM	25 KHz	450.1250	5	37.19	36.99 ± 1	Complicance

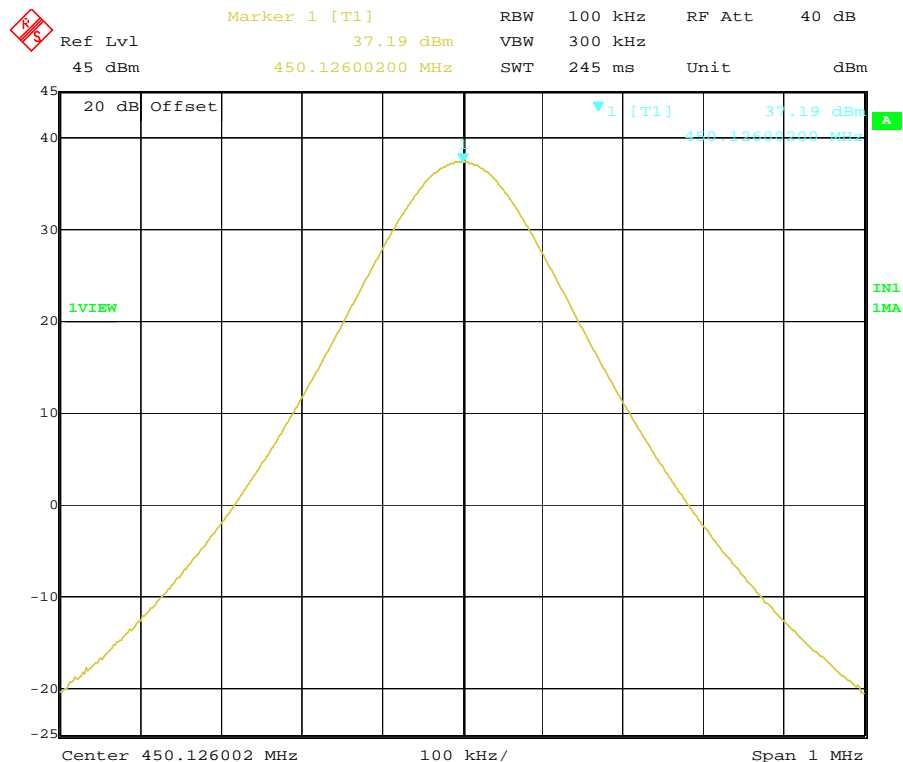

Date: 26.NOV.2010 23:08:54

Modulation Type	Channel Separation	Freq.(MHz)	Rated Power (Watt)	Measurement (dBm)	IC Limit (dBm)	Results
FM	25 KHz	460.1250	5	37.42	36.99±1	Complicance

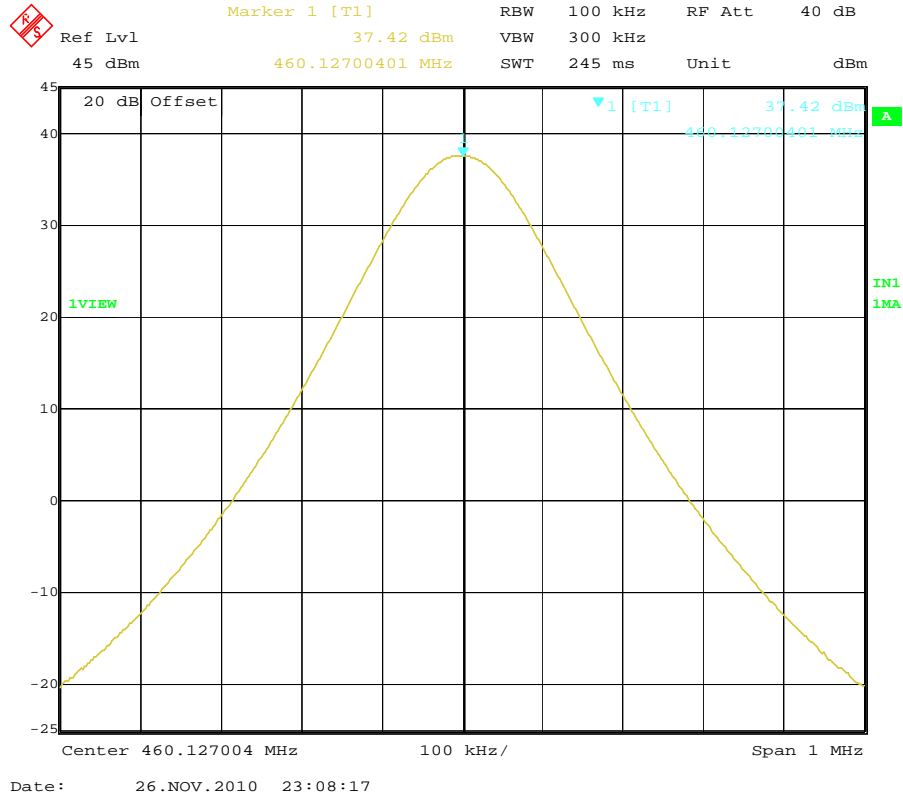

Modulation Type	Channel Separation	Freq.(MHz)	Rated Power (Watt)	Measurement (dBm)	IC Limit (dBm)	Results
FM	25 KHz	469.9875	5	37.39	36.99±1	Complicance

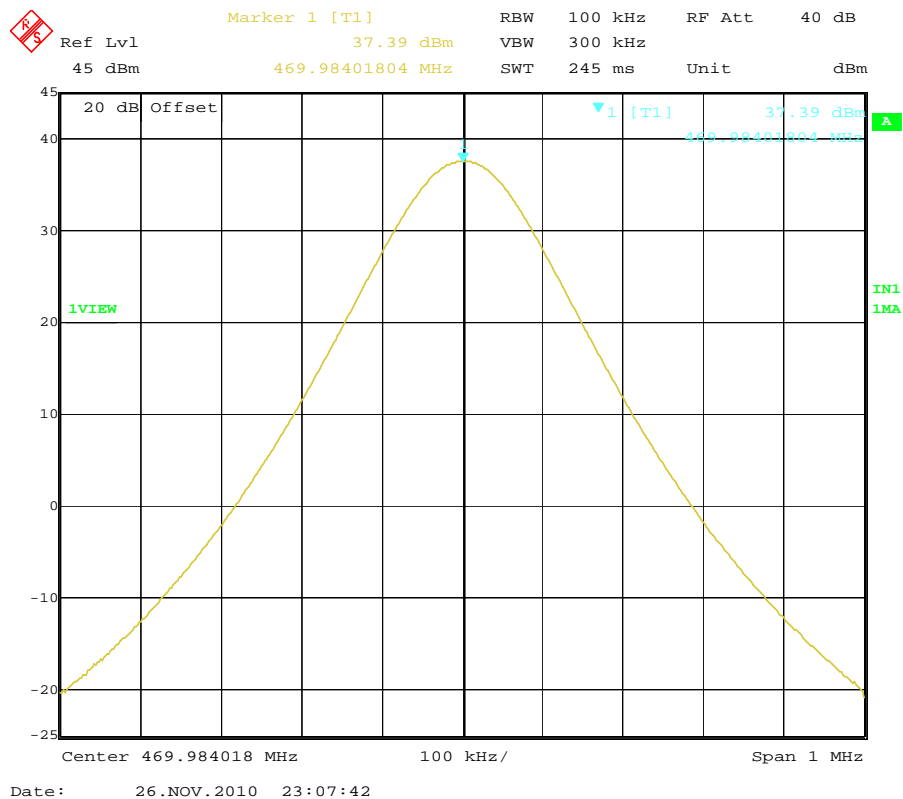

Modulation Type	Channel Separation	Freq.(MHz)	Rated Power (Watt)	Measurement (dBm)	IC Limit (dBm)	Results
FM	12.5 KHz	450.1250	5	37.18	36.99±1	Complicance

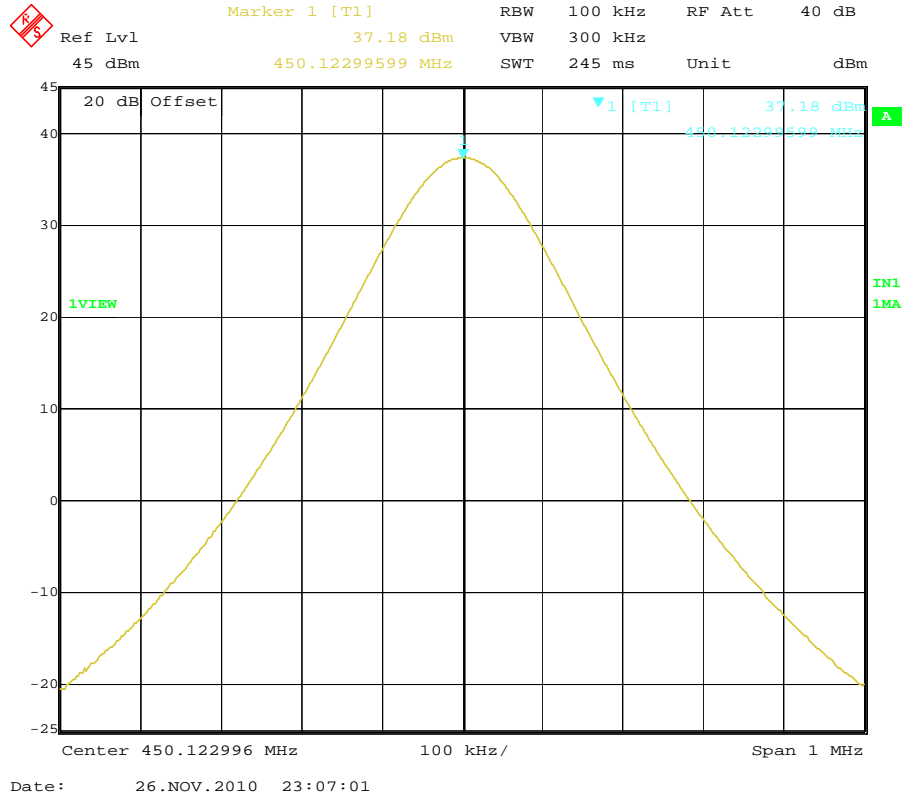

Modulation Type	Channel Separation	Freq.(MHz)	Rated Power (Watt)	Measurement (dBm)	IC Limit (dBm)	Results
FM	12.5 KHz	460.1250	5	37.44	36.99±1	Complicance

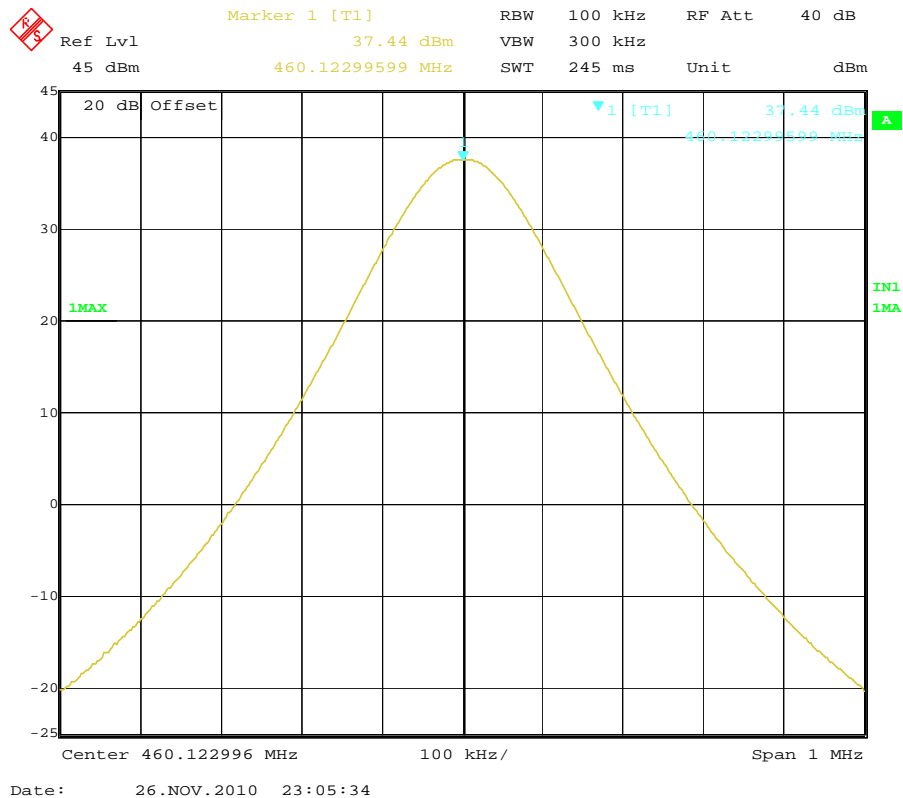

Modulation Type	Channel Separation	Freq.(MHz)	Rated Power (Watt)	Measurement (dBm)	IC Limit (dBm)	Results
FM	12.5 KHz	469.9875	5	37.45	36.99±1	Complicance

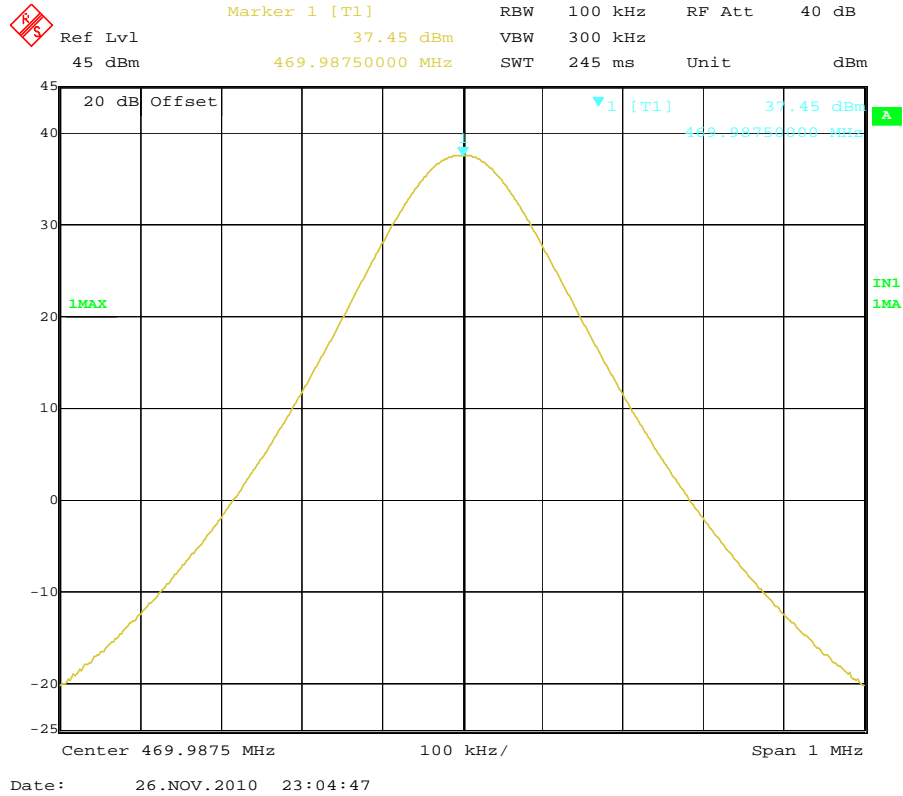

4.8. Transmitter Frequency Behavior

TEST APPLICABLE

Section 90.214 and ESS-119 Section 5.9

Transient frequencies must be within the maximum frequency difference limits during the time intervals indicated:

Time intervals ^{1, 2}	Maximum frequency difference ³	All equipment	
		150 to 174 MHz	421 to 512MHz
Transient Frequency Behavior for Equipment Designed to Operate on 25 KHz Channels			
t ₁ ⁴	± 25.0 KHz	5.0 ms	10.0 ms
t ₂ ⁴	± 12.5 KHz	20.0 ms	25.0 ms
t ₃ ⁴	± 25.0 KHz	5.0 ms	10.0 ms
Transient Frequency Behavior for Equipment Designed to Operate on 12.5 KHz Channels			
t ₁ ⁴	± 12.5 KHz	5.0 ms	10.0 ms
t ₂ ⁴	± 6.25 KHz	20.0 ms	25.0 ms
t ₃ ⁴	± 12.5 KHz	5.0 ms	10.0 ms
Transient Frequency Behavior for Equipment Designed to Operate on 6.25 KHz Channels			
t ₁ ⁴	±6.25 KHz	5.0 ms	10.0 ms
t ₂ ⁴	±3.125 KHz	20.0 ms	25.0 ms
t ₃ ⁴	±6.25 KHz	5.0 ms	10.0 ms

- t_{on} is the instant when a 1 KHz test signal is completely suppressed, including any capture time due to phasing.
 t₁ is the time period immediately following t_{on}.
 t₂ is the time period immediately following t₁.
 t₃ is the time period from the instant when the transmitter is turned off until t_{off}.
 t_{off} is the instant when the 1 KHz test signal starts to rise.
- During the time from the end of t₂ to the beginning of t₃, the frequency difference must not exceed the limits specified in § 90.213.
- Difference between the actual transmitter frequency and the assigned transmitter frequency.
- If the transmitter carrier output power rating is 6 watts or less, the frequency difference during this time period may exceed the maximum frequency difference for this time period.

TEST PROCEDURE

TIA/EIA-603 2.2.19

TEST CONFIGURATION

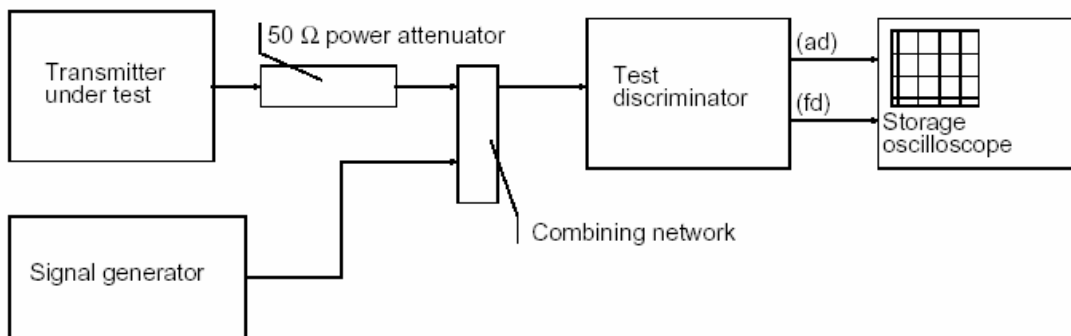

TEST RESULTS

For FCC

Please refer to the following plots.

Transmitter Frequency Behaviour @ 12.5 KHz Channel Separation-----Off – On

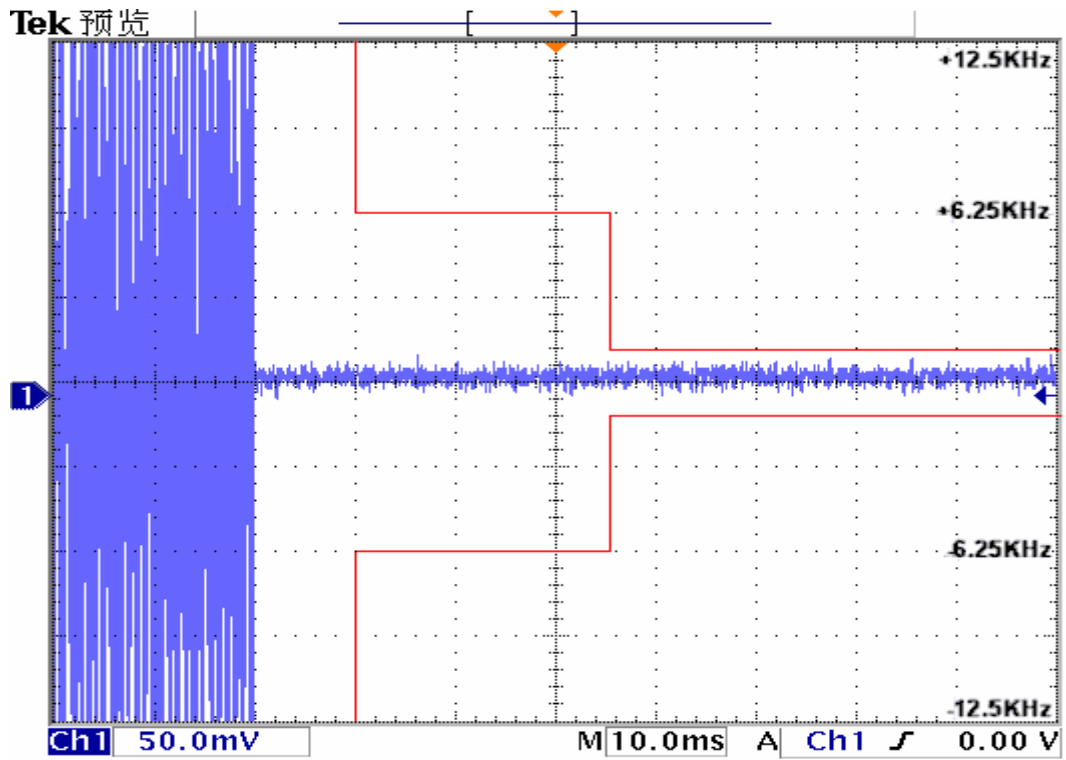

Transmitter Frequency Behaviour @ 12.5 KHz Channel Separation-----On - Off

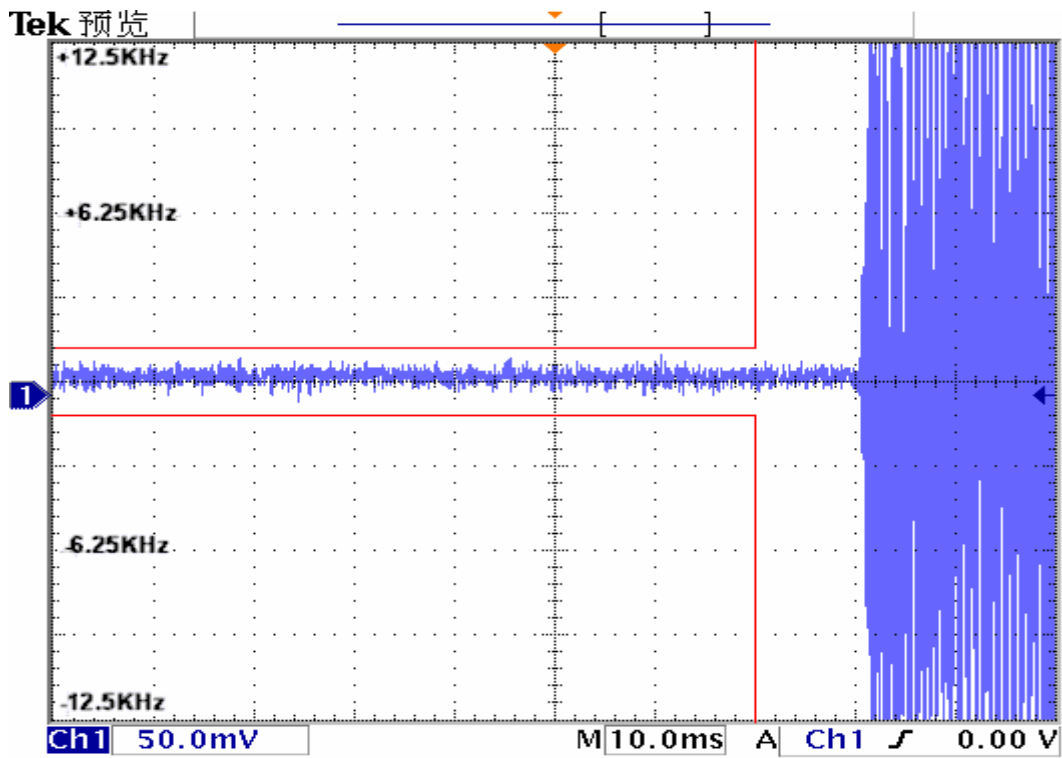

Transmitter Frequency Behaviour @ 25 KHz Channel Separation-----Off – On

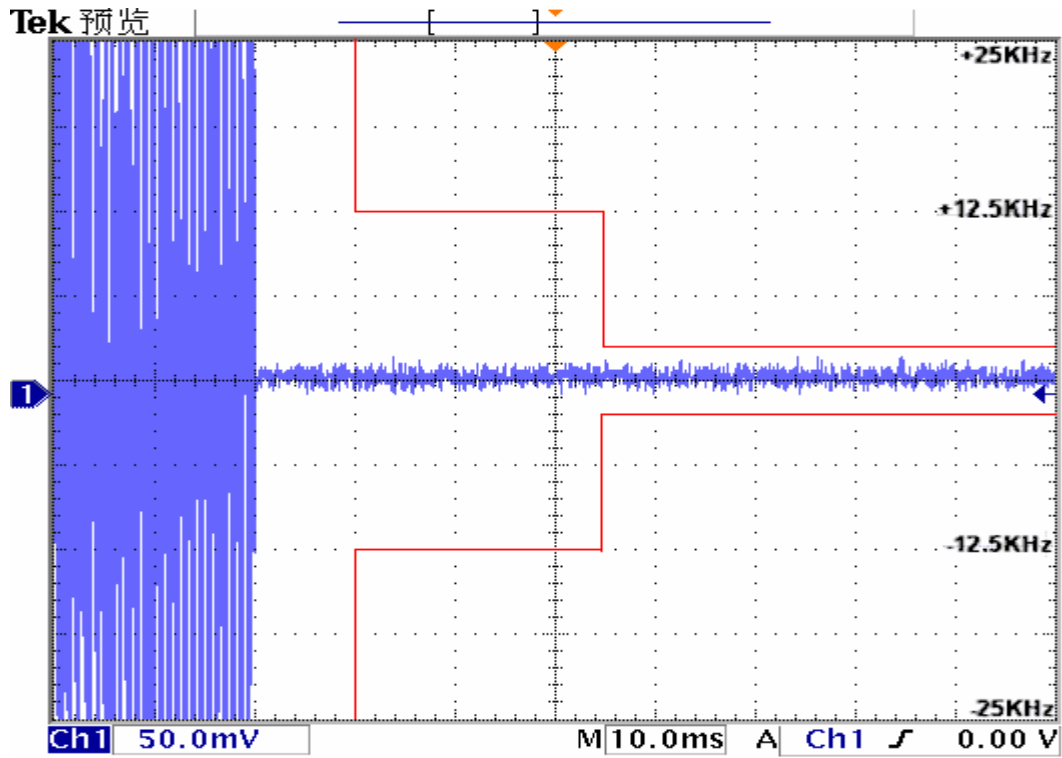

Transmitter Frequency Behaviour @ 25 KHz Channel Separations-----On – Off

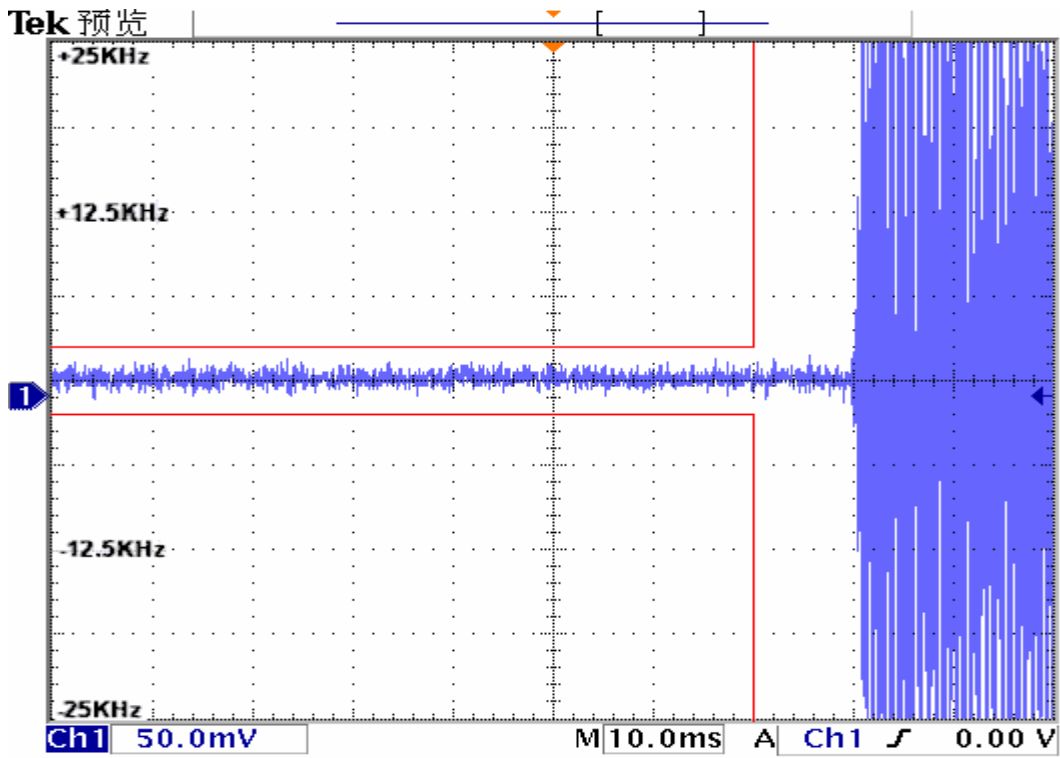

For IC

Please refer to the following plots.

Transmitter Frequency Behaviour @ 12.5 KHz Channel Separation-----Off – On

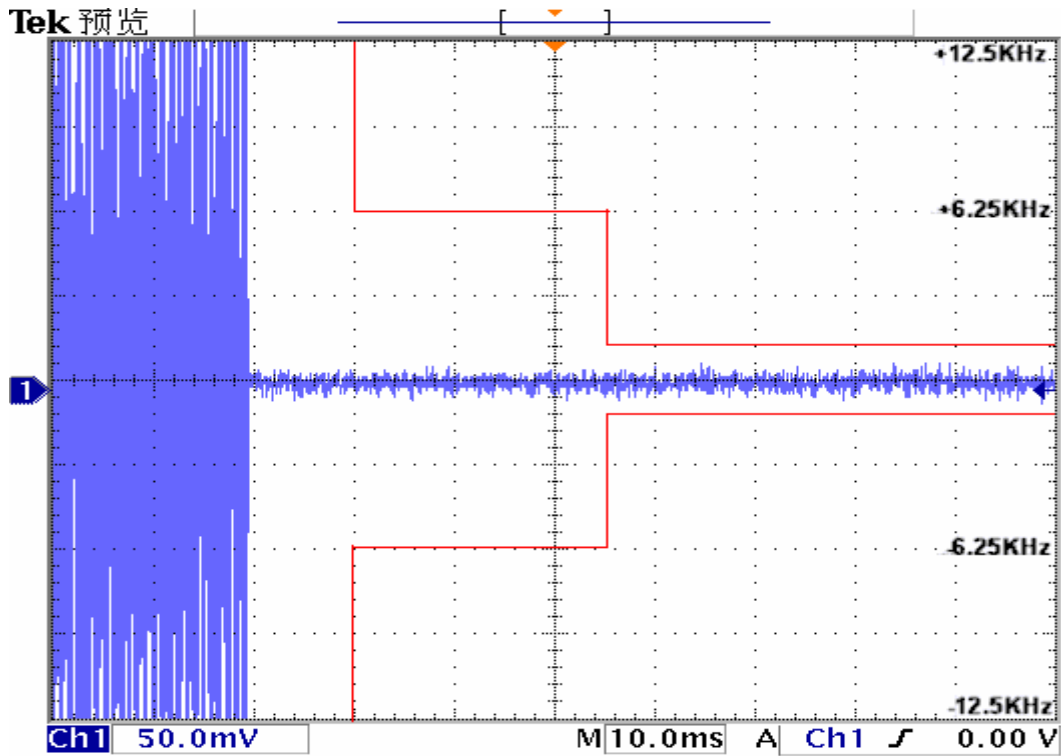

Transmitter Frequency Behaviour @ 12.5 KHz Channel Separation-----On - Off

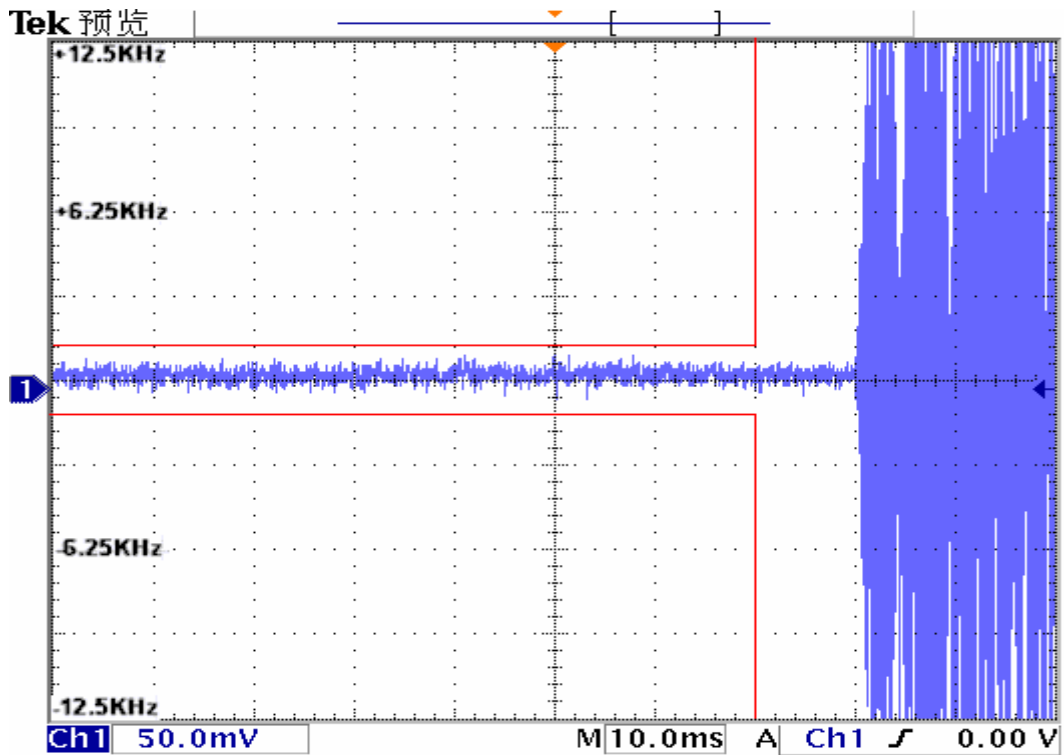

Transmitter Frequency Behaviour @ 25 KHz Channel Separation-----Off – On

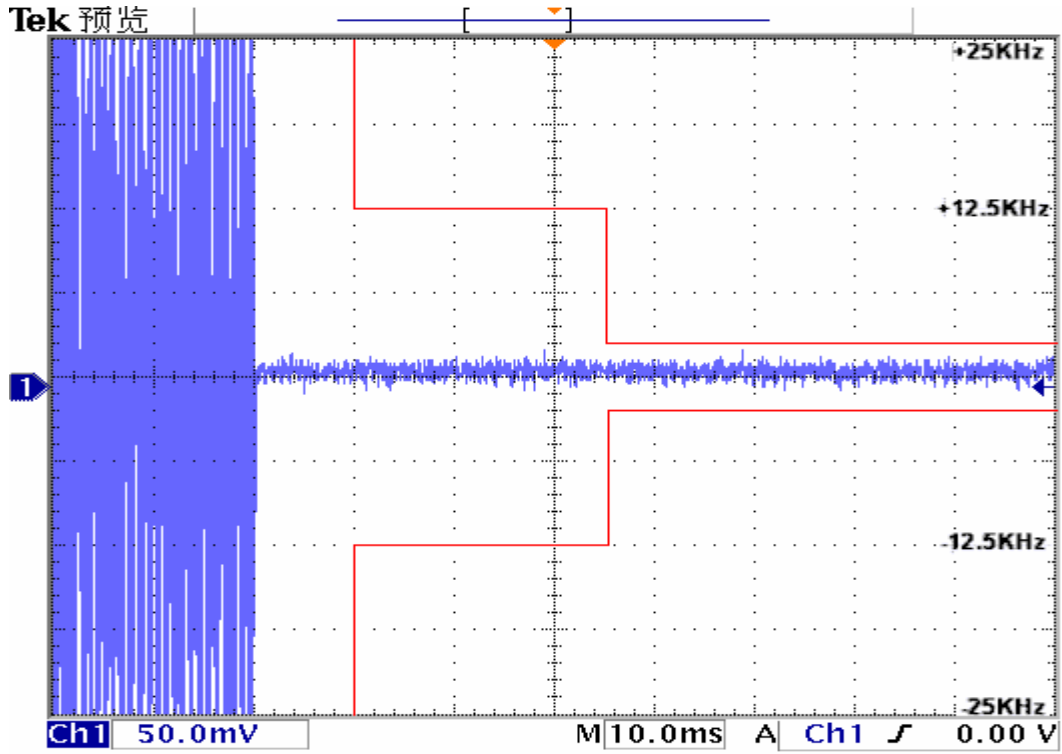

Transmitter Frequency Behaviour @ 25 KHz Channel Separations-----On – Off

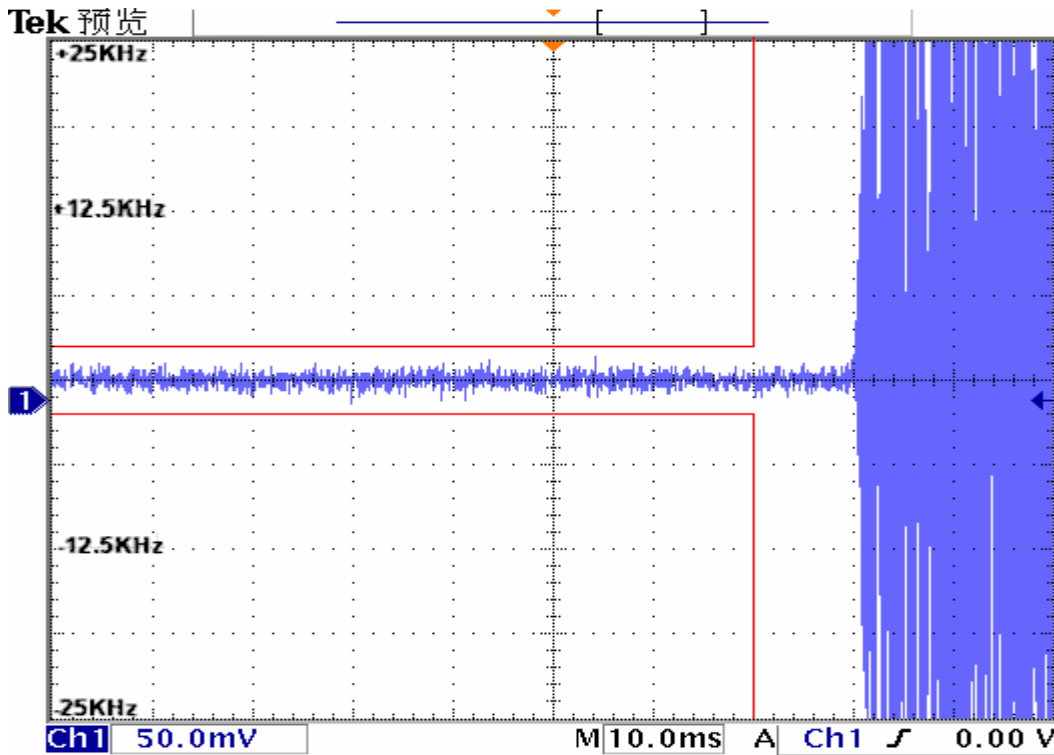

4.9. Receiver Radiated Spurious Emission

TEST APPLICABLE

The field strength is calculated by adding the Antenna Factor and Cable Factor and subtracting the Amplifier Gain and Duty Cycle Correction Factor(if any) from the measured reading. The basic equation with a sample calculation is as follows:

$$FS = RA + AF + CL - AG$$

Where FS = Field Strength	CL = Cable Attenuation Factor (Cable Loss)
RA = Reading Amplitude	AG = Amplifier Gain
AF = Antenna Factor	

TEST CONFIGURATION

(A) Radiated Emission Test Set-Up, Frequency below 1000MHz

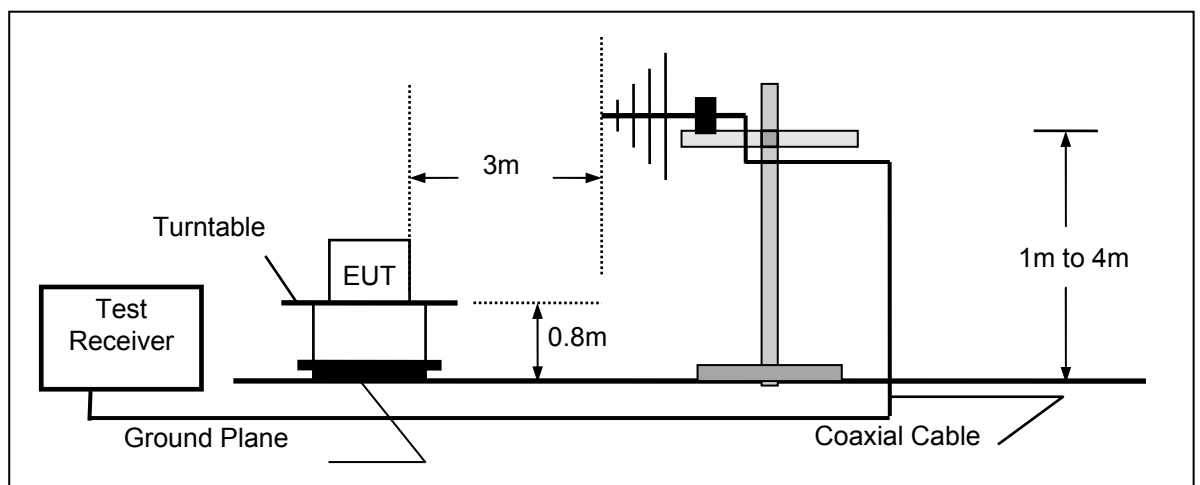

(B) Radiated Emission Test Set-Up, Frequency above 1000MHz

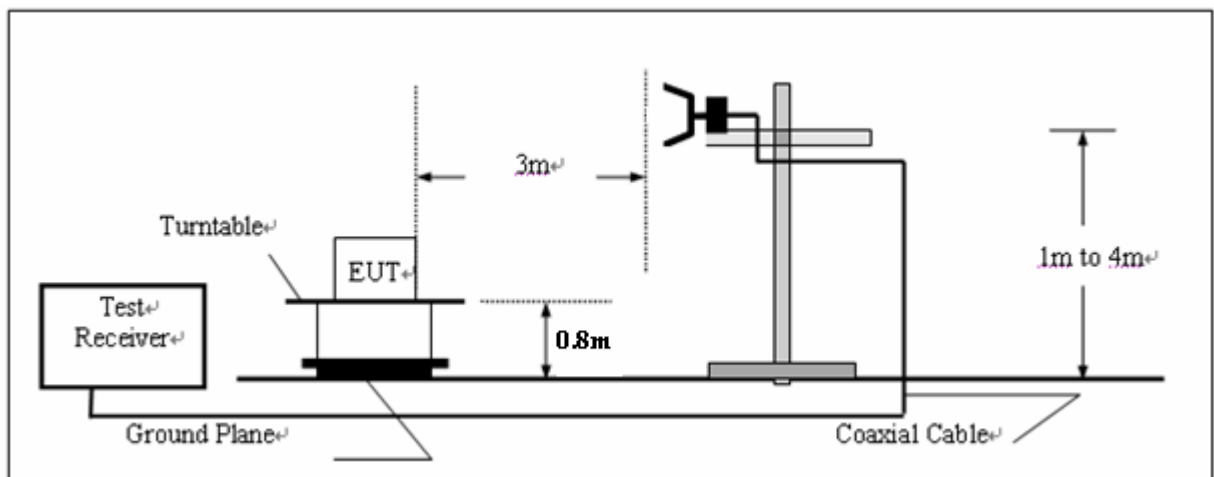

TEST PROCEDURE

- 1 The EUT was placed on a turn table which is 0.8m above ground plane.
- 2 Maximum procedure was performed by raising the receiving antenna from 1m to 4m and rotating the turn table from 0° to 360° to acquire the highest emissions from EUT
- 3 And also, each emission was to be maximized by changing the polarization of receiving antenna both horizontal and vertical.
- 4 Repeat above procedures until all frequency measurements have been completed.

RECEIVER RADIATED SPOUIOUS LIMIT

For unintentional device, according to § 15.109(a) and RSS-Gen, except for Class A digital devices, the field strength of radiated emissions from unintentional radiators at a distance of 3 meters shall not exceed the following values:

Frequency (MHz)	Distance (Meters)	Radiated (dB μ V/m)	Radiated (μ V/m)
30-88	3	40.0	100
88-216	3	43.5	150
216-960	3	46.0	200
Above 960	3	54.0	500

For intentional device, according to § 15.209(a), the general requirement of field strength of radiated emissions from intentional radiators at a distance of 3 meters shall not exceed the above table.

TEST RESULTS

The Radiated Measurement are performed to the three channels (the top channel, the middle channel and the bottom channel), the datum recorded below is the worst case for each channel separation; and the EUT shall be scanned from 30 MHz to the 5th harmonic of the highest oscillator frequency in the digital devices or 1 GHz whichever is higher.

For FCC

Modulation Type	Channel Separation	Test Frequency (MHz)	Polar.	Maximum Radiated Emissions		FCC Limit (dBuV/m)
				Frequency (MHz)	Datum (dBuV/m)	
FM	25 KHz	489.9875	H	440.16	42.90	46
			V	37.78	35.70	40
Test Results			Compliance			

SWEEP TABLE: "test (30M-1G)"

Short Description: Field Strength
 Start Stop Detector Meas. IF Transducer
 Frequency Frequency Time Bandw.
 30.0 MHz 1.0 GHz MaxPeak Coupled 120 kHz HL562 2010

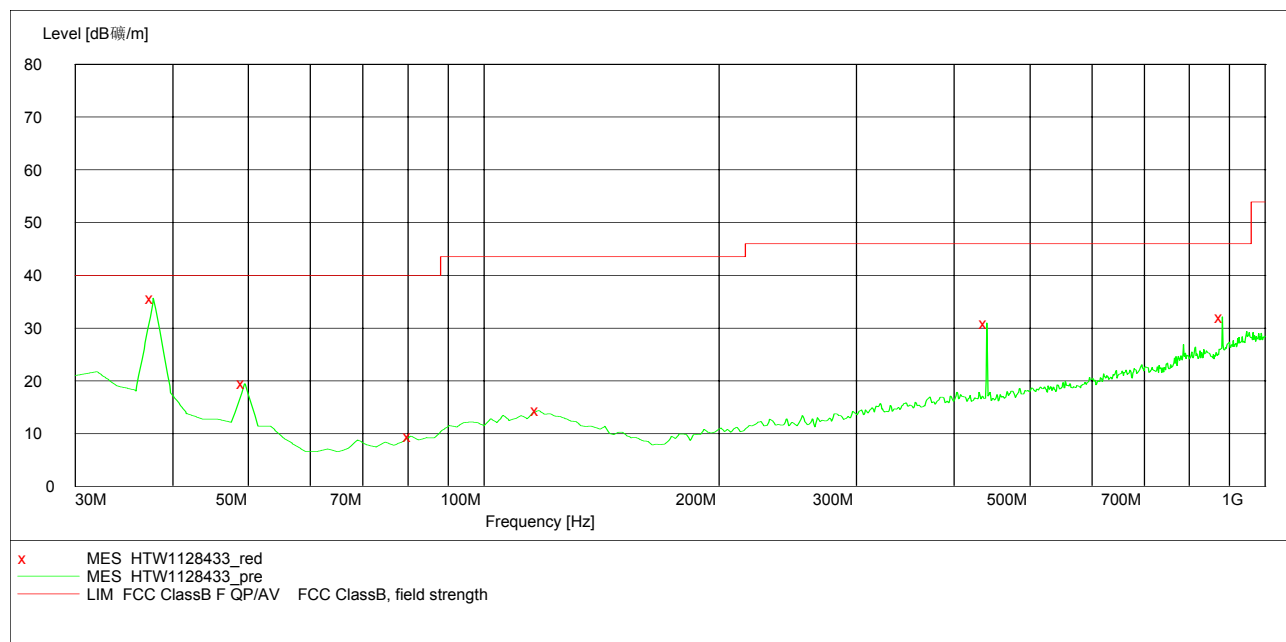

MEASUREMENT RESULT: "HTW1128433_red"

11/28/2010 3:49PM

Frequency MHz	Level dBuV/m	Transd dB	Limit dBuV/m	Margin dB	Det.	Height cm	Azimuth deg	Polarization
37.775551	35.70	-14.5	40.0	4.3	Peak	100.0	189.00	VERTICAL
49.438878	19.50	-20.9	40.0	20.5	Peak	100.0	350.00	VERTICAL
80.541082	9.50	-22.5	40.0	30.5	Peak	100.0	327.00	VERTICAL
117.474950	14.40	-18.5	43.5	29.1	Peak	100.0	134.00	VERTICAL
440.160321	31.00	-15.4	46.0	15.0	Peak	100.0	90.00	VERTICAL
881.422846	32.10	-7.4	46.0	13.9	Peak	100.0	134.00	VERTICAL

SWEEP TABLE: "test (30M-1G)"

Short Description:		Field Strength			
Start	Stop	Detector	Meas.	IF	Transducer
Frequency	Frequency		Time	Bandw.	
30.0 MHz	1.0 GHz	MaxPeak	Coupled	120 kHz	HL562 2010

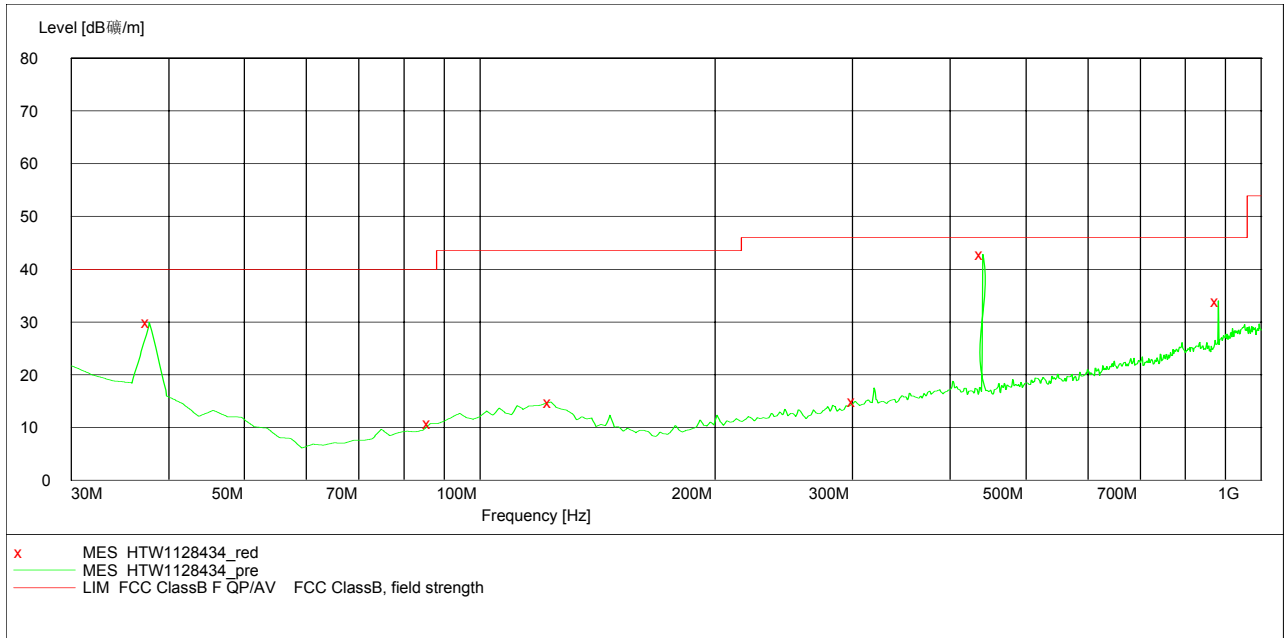

MEASUREMENT RESULT: "HTW1128434_red"

11/28/2010 4:12PM

Frequency MHz	Level dBµV/m	Transd dB	Limit dBµV/m	Margin dB	Det.	Height cm	Azimuth deg	Polarization
37.775551	29.90	-14.5	40.0	10.1	Peak	300.0	264.00	HORIZONTAL
86.372745	10.70	-21.7	40.0	29.3	Peak	100.0	276.00	HORIZONTAL
123.306613	14.80	-18.4	43.5	28.7	Peak	100.0	330.00	HORIZONTAL
302.144289	14.90	-18.0	46.0	31.1	Peak	100.0	70.00	HORIZONTAL
440.160321	42.90	-15.4	46.0	3.1	Peak	100.0	0.00	HORIZONTAL
881.422846	34.00	-7.4	46.0	12.0	Peak	100.0	245.00	HORIZONTAL

Modulation Type	Channel Separation	Test Frequency (MHz)	Polar.	Maximum Radiated Emissions		FCC Limit (dBuV/m)
				Frequency (MHz)	Datum (dBuV/m)	
FM	12.5 KHz	489.9875	H	440.16	42.30	46
			V	37.77	35.90	40
Test Results			Compliance			

SWEEP TABLE: "test (30M-1G)"

Short Description: Field Strength
 Start Stop Detector Meas. IF Transducer
 Frequency Frequency Time Bandw.
 30.0 MHz 1.0 GHz MaxPeak Coupled 120 kHz HL562 2010

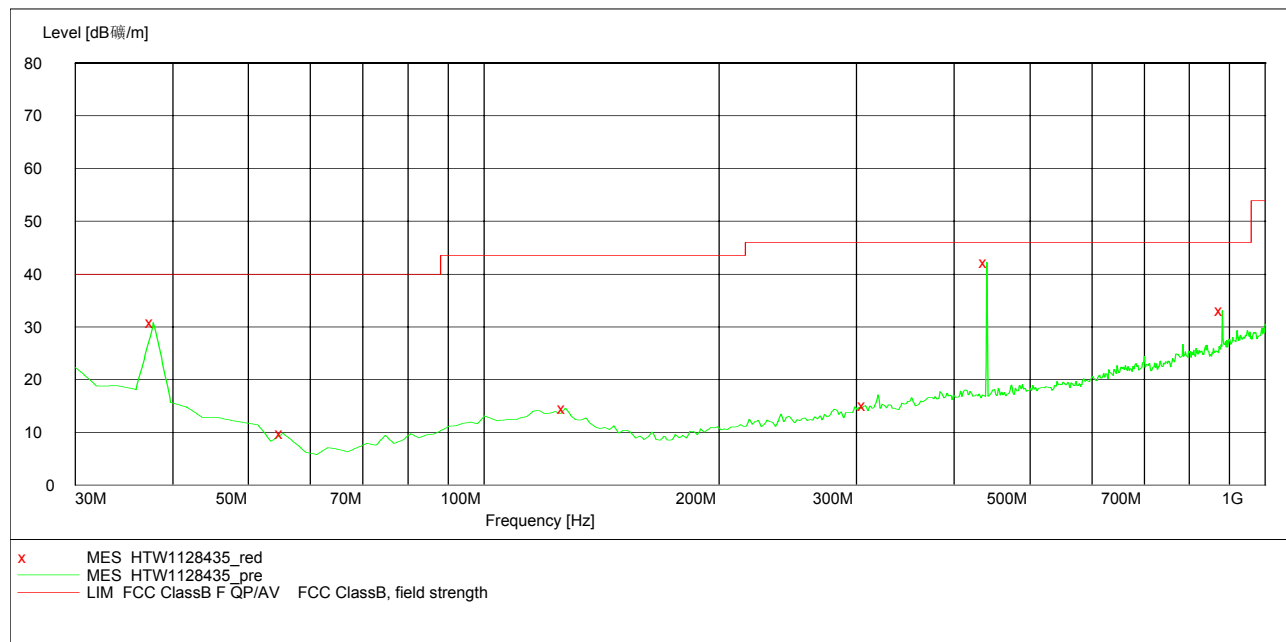

MEASUREMENT RESULT: "HTW1128435_red"

11/28/2010 4:11PM

Frequency MHz	Level dBμV/m	Transd dB	Limit dBμV/m	Margin dB	Det.	Height cm	Azimuth deg	Polarization
37.775551	30.80	-14.5	40.0	9.2	Peak	300.0	124.00	HORIZONTAL
55.270541	9.80	-23.6	40.0	30.2	Peak	300.0	274.00	HORIZONTAL
127.194389	14.60	-18.9	43.5	28.9	Peak	300.0	346.00	HORIZONTAL
307.975952	15.10	-17.8	46.0	30.9	Peak	100.0	121.00	HORIZONTAL
440.160321	42.30	-15.4	46.0	3.7	Peak	100.0	0.00	HORIZONTAL
881.422846	33.10	-7.4	46.0	12.9	Peak	100.0	134.00	HORIZONTAL

SWEEP TABLE: "test (30M-1G)"

Short Description:		Field Strength			
Start	Stop	Detector	Meas.	IF	Transducer
Frequency	Frequency		Time	Bandw.	
30.0 MHz	1.0 GHz	MaxPeak	Coupled	120 kHz	HL562 2010

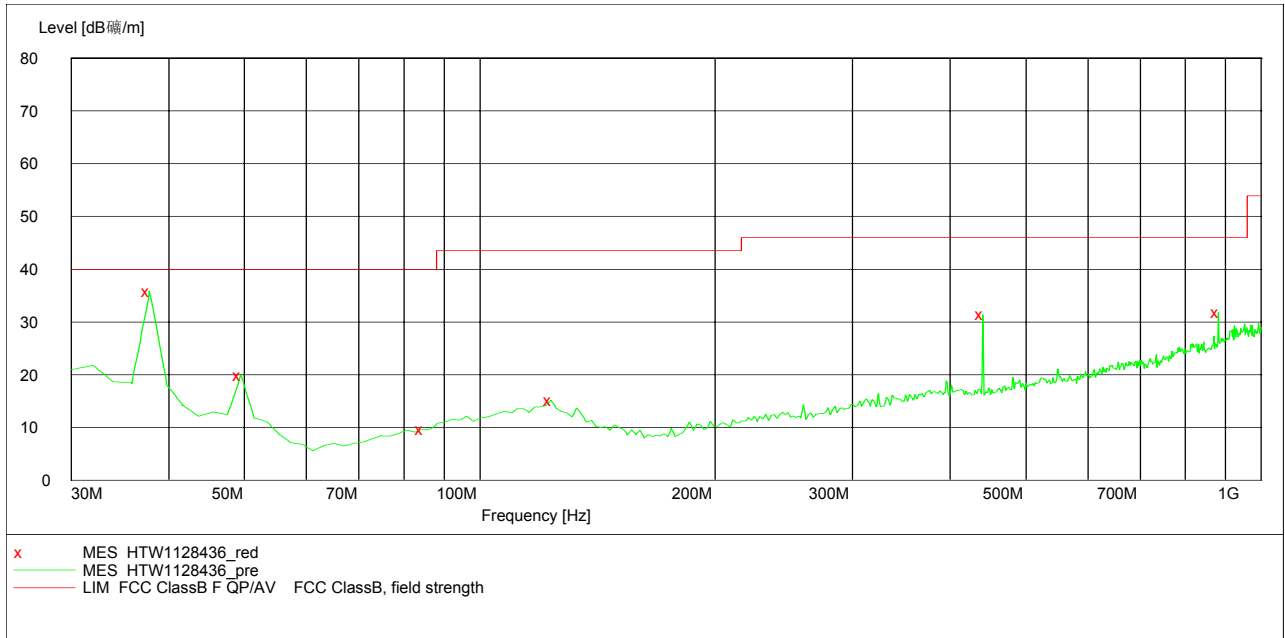

MEASUREMENT RESULT: "HTW1128436_red"

11/28/2010 3:58PM

Frequency MHz	Level dBµV/m	Transd dB	Limit dBµV/m	Margin dB	Det.	Height cm	Azimuth deg	Polarization
37.775551	35.90	-14.5	40.0	4.1	Peak	100.0	198.00	VERTICAL
49.438878	19.90	-20.9	40.0	20.1	Peak	100.0	325.00	VERTICAL
84.428858	9.70	-22.2	40.0	30.3	Peak	100.0	126.00	VERTICAL
123.306613	15.20	-18.4	43.5	28.3	Peak	100.0	216.00	VERTICAL
440.160321	31.40	-15.4	46.0	14.6	Peak	100.0	53.00	VERTICAL
881.422846	31.80	-7.4	46.0	14.2	Peak	100.0	53.00	VERTICAL

For IC

Modulation Type	Channel Separation	Test Frequency (MHz)	Polar.	Maximum Radiated Emissions		FCC Limit (dBuV/m)
				Frequency (MHz)	Datum (dBuV/m)	
FM	25 KHz	469.9875	H	420.72	43.00	46
			V	37.78	35.30	40
Test Results			Compliance			

SWEEP TABLE: "test (30M-1G)"

Short Description:		Field Strength			
Start	Stop	Detector	Meas.	IF	Transducer
Frequency	Frequency		Time	Bandw.	
30.0 MHz	1.0 GHz	MaxPeak	Coupled	120 kHz	HL562 2010

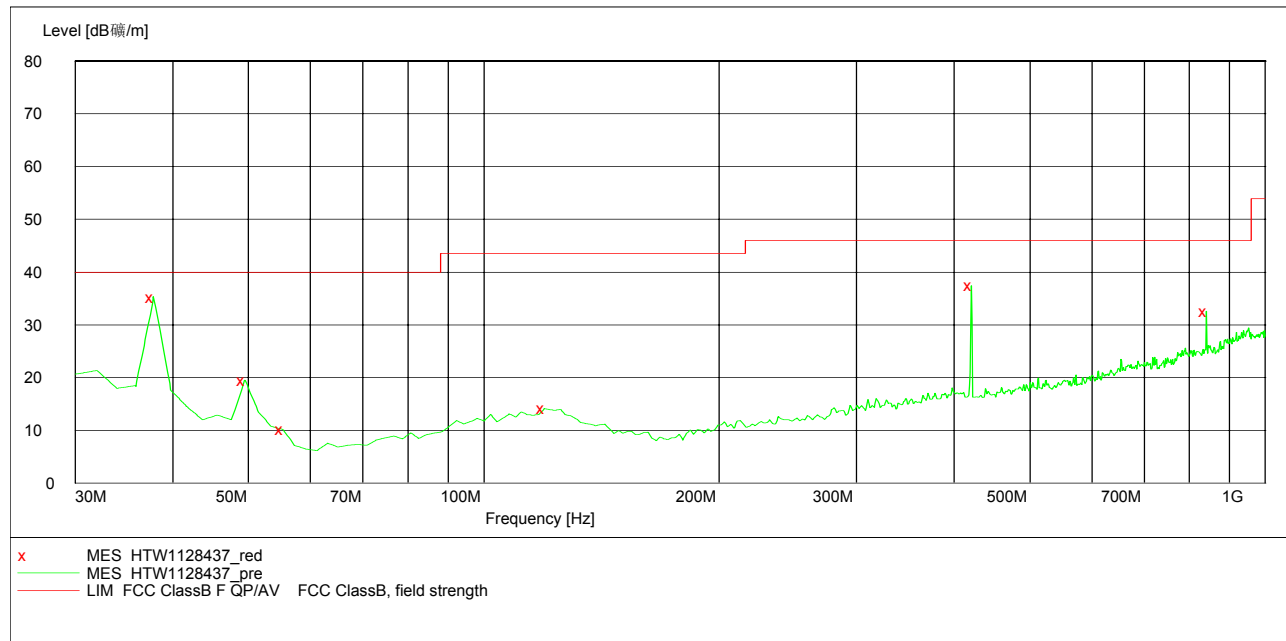

MEASUREMENT RESULT: "HTW1128437_red"

11/28/2010 4:00PM

Frequency MHz	Level dBμV/m	Transd dB	Limit dBμV/m	Margin dB	Det.	Height cm	Azimuth deg	Polarization
37.775551	35.30	-14.5	40.0	4.7	Peak	100.0	236.00	VERTICAL
49.438878	19.50	-20.9	40.0	20.5	Peak	100.0	279.00	VERTICAL
55.270541	10.20	-23.6	40.0	29.8	Peak	100.0	96.00	VERTICAL
119.418838	14.10	-18.4	43.5	29.4	Peak	100.0	304.00	VERTICAL
420.721443	37.40	-15.8	46.0	8.6	Peak	100.0	152.00	VERTICAL
840.601202	32.60	-8.0	46.0	13.4	Peak	100.0	118.00	VERTICAL

SWEEP TABLE: "test (30M-1G)"

Short Description:		Field Strength			
Start	Stop	Detector	Meas.	IF	Transducer
Frequency	Frequency		Time	Bandw.	
30.0 MHz	1.0 GHz	MaxPeak	Coupled	120 kHz	HL562 2010

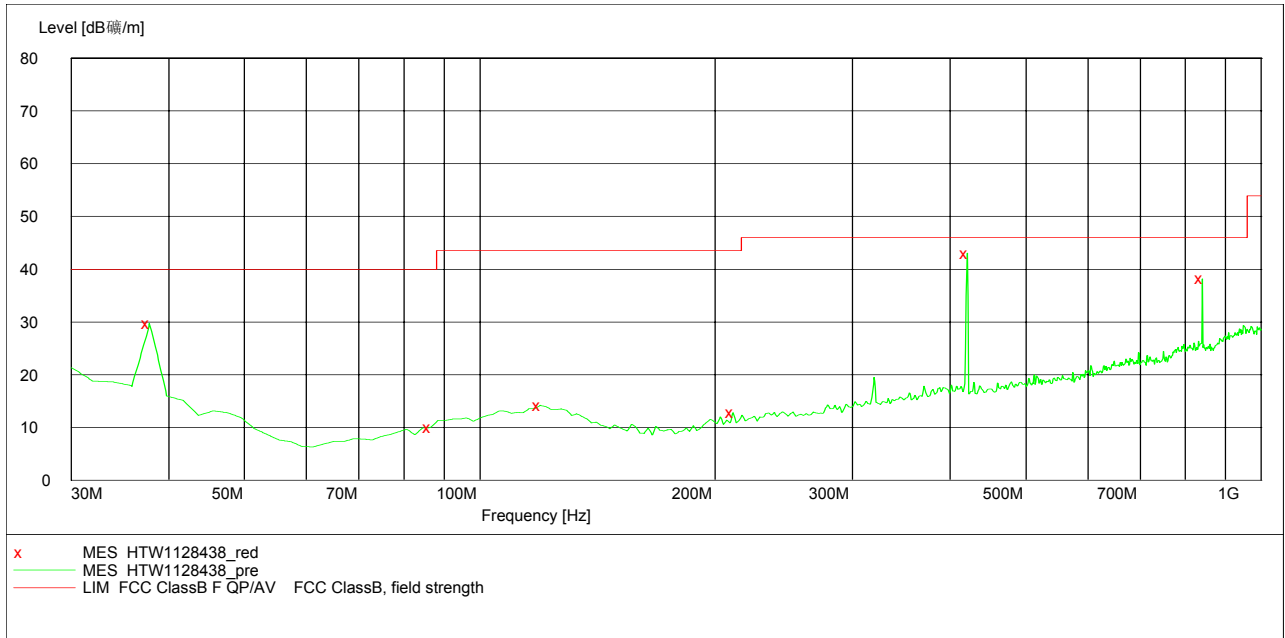

MEASUREMENT RESULT: "HTW1128438_red"

11/28/2010 4:09PM

Frequency MHz	Level dBµV/m	Transd dB	Limit dBµV/m	Margin dB	Det.	Height cm	Azimuth deg	Polarization
37.775551	29.70	-14.5	40.0	10.3	Peak	300.0	119.00	HORIZONTAL
86.372745	10.00	-21.7	40.0	30.0	Peak	300.0	98.00	HORIZONTAL
119.418838	14.20	-18.4	43.5	29.3	Peak	300.0	180.00	HORIZONTAL
210.781563	12.80	-21.2	43.5	30.7	Peak	100.0	320.00	HORIZONTAL
420.721443	43.00	-15.8	46.0	3.0	Peak	100.0	300.00	HORIZONTAL
840.601202	38.20	-8.0	46.0	7.8	Peak	100.0	232.00	HORIZONTAL

Modulation Type	Channel Separation	Test Frequency (MHz)	Polar.	Maximum Radiated Emissions		FCC Limit (dBuV/m)
				Frequency (MHz)	Datum (dBuV/m)	
FM	12.5 KHz	469.9875	H	420.72	43.00	46
			V	37.78	36.00	40
Test Results			Compliance			

SWEEP TABLE: "test (30M-1G)"

Short Description: Field Strength
 Start Stop Detector Meas. IF Transducer
 Frequency Frequency Time Bandw.
 30.0 MHz 1.0 GHz MaxPeak Coupled 120 kHz HL562 2010

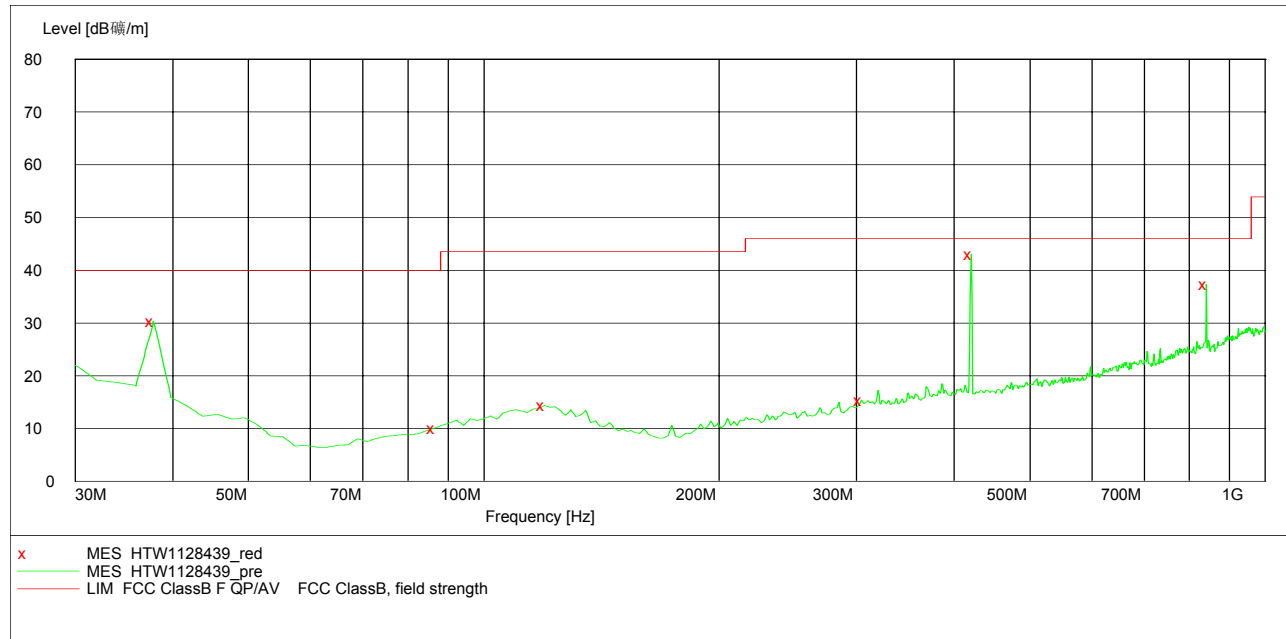

MEASUREMENT RESULT: "HTW1128439_red"

11/28/2010 4:09PM

Frequency MHz	Level dBµV/m	Transd dB	Limit dBµV/m	Margin dB	Det.	Height cm	Azimuth deg	Polarization
37.775551	30.40	-14.5	40.0	9.6	Peak	300.0	126.00	HORIZONTAL
86.372745	10.10	-21.7	40.0	29.9	Peak	300.0	126.00	HORIZONTAL
119.418838	14.40	-18.4	43.5	29.1	Peak	300.0	255.00	HORIZONTAL
304.088176	15.40	-17.9	46.0	30.6	Peak	300.0	255.00	HORIZONTAL
420.721443	43.00	-15.8	46.0	3.0	Peak	100.0	297.00	HORIZONTAL
840.601202	37.40	-8.0	46.0	8.6	Peak	100.0	231.00	HORIZONTAL

SWEEP TABLE: "test (30M-1G)"

Short Description:		Field Strength			
Start	Stop	Detector	Meas.	IF	Transducer
Frequency	Frequency		Time	Bandw.	
30.0 MHz	1.0 GHz	MaxPeak	Coupled	120 kHz	HL562 2010

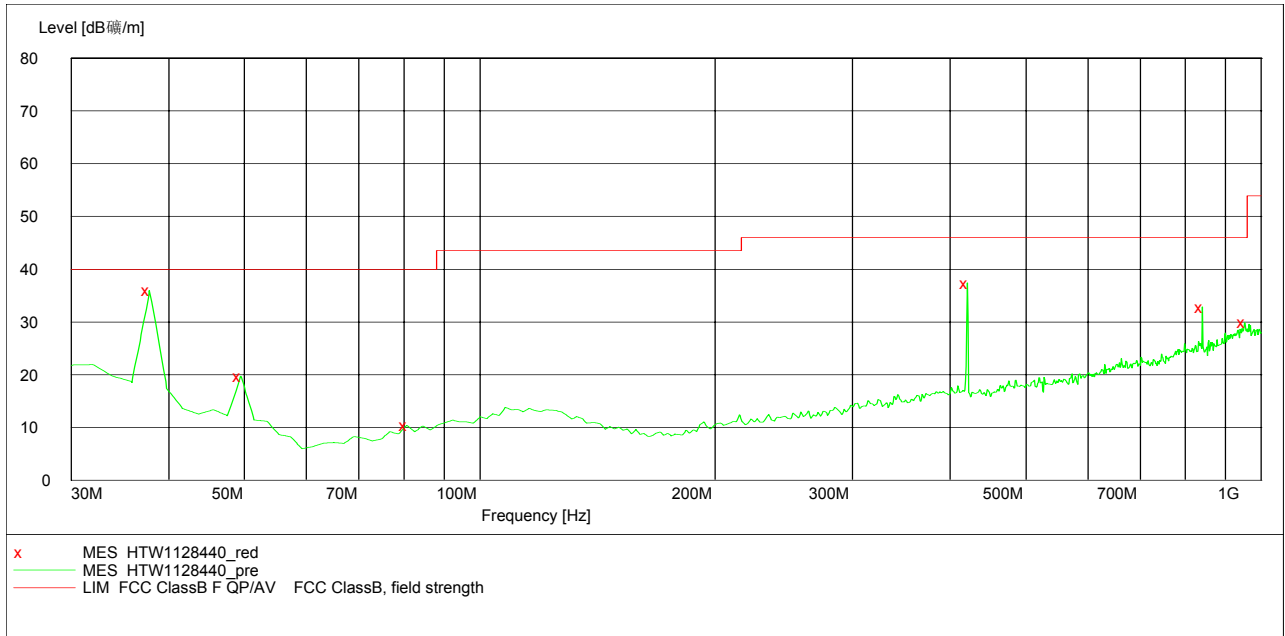

MEASUREMENT RESULT: "HTW1128440_red"

11/28/2010 4:07PM

Frequency MHz	Level dBµV/m	Transd dB	Limit dBµV/m	Margin dB	Det.	Height cm	Azimuth deg	Polarization
37.775551	36.00	-14.5	40.0	4.0	Peak	100.0	197.00	VERTICAL
49.438878	19.70	-20.9	40.0	20.3	Peak	100.0	221.00	VERTICAL
80.541082	10.40	-22.5	40.0	29.6	Peak	100.0	190.00	VERTICAL
420.721443	37.40	-15.8	46.0	8.6	Peak	100.0	154.00	VERTICAL
840.601202	32.80	-8.0	46.0	13.2	Peak	100.0	119.00	VERTICAL
951.402806	29.90	-5.1	46.0	16.1	Peak	100.0	101.00	VERTICAL

4.10. Receiver Conducted Spurious Emssion

TEST APPLICABLE

The same as Section 4.3

TEST PROCEDURE

The spectrum analyzer was connected to the RF output power of the EUT, the EUT was setup in receiving mode; The RBW of the spectrum analyzer was set to 100 kHz and the VBW set to 300 KHz below the test frequency 1GHz. While the RBW of the spectrum analyzer was set to the 1MHz and VBW set to the 3MHz from 1GHz to the 10th harmonic.

TEST CONFIGURATION

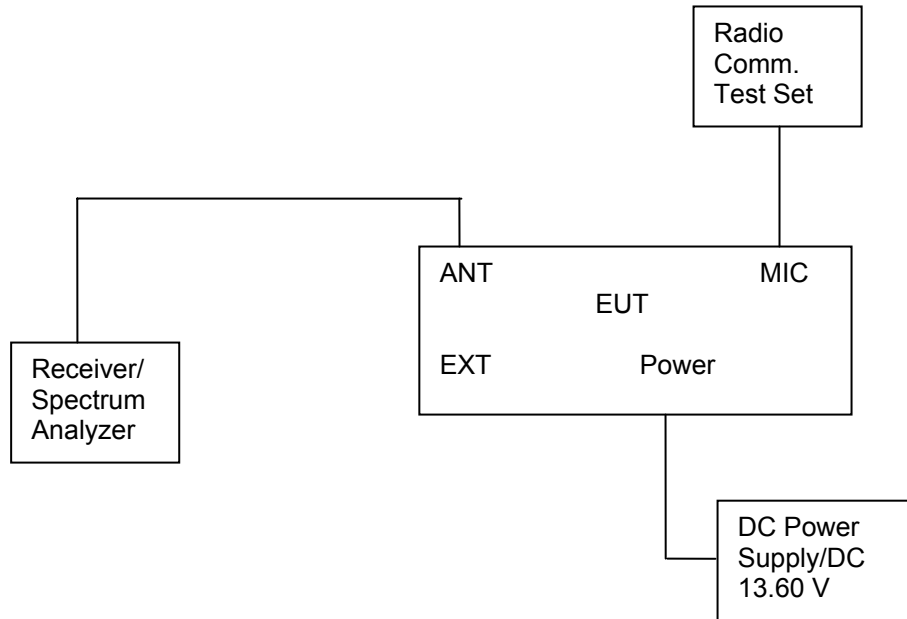

LIMIT

The power at the antenna terminal shall not exceed 2.0 nanowatts (-57dBm).

TEST RESULTS

The Receiver Conducted Spurious Emssions Measurement is performed to the three channels (the high channel, the middle channel and the low channel), the datums recorded below were for the three channels; and the EUT shall be scanned from 30 MHz to the 5 GHz.

For FCC

Modulation Type	Channel SpARATION	Test Channel	Test Frequency (MHz)	Maximum Conducted Spurious Emissions Below 1GHz		Maximum Conducted Spurious Emissions Above 1GHz		FCC Limit
				Frequency (MHz)	Datum (dBm)	Frequency (MHz)	Datum (dBm)	
FM	25KHz	Low	438.1250	387.68	-80.21	3989.98	-78.48	-57dBm
Test Results				Compliance				

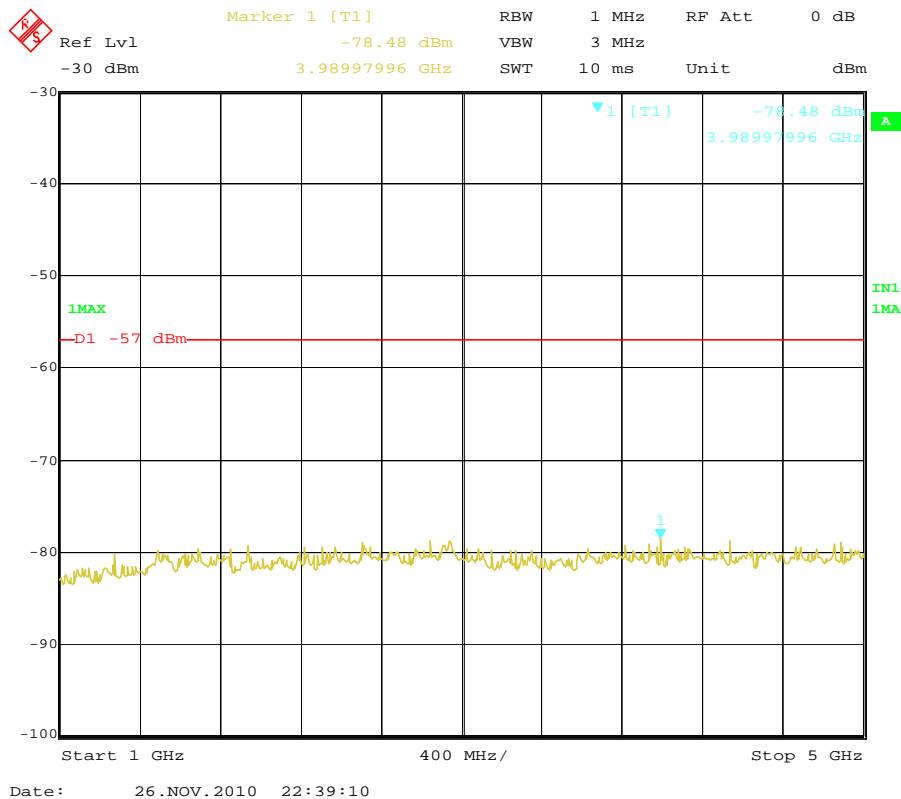
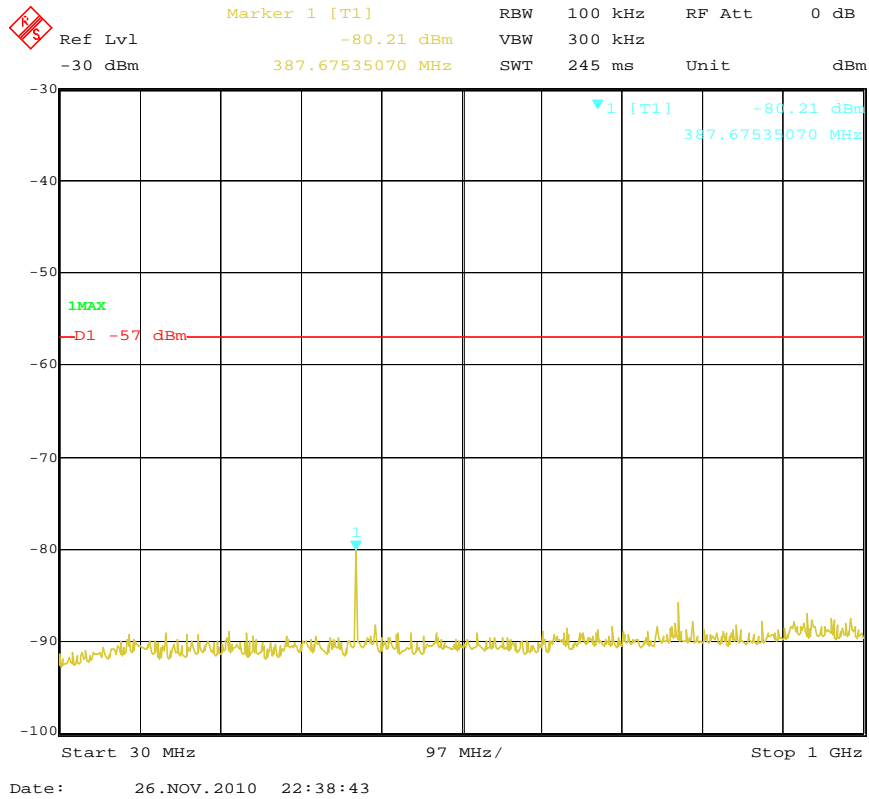

Modulation Type	Channel SpARATION	Test Channel	Test Frequency (MHz)	Maximum Conducted Spurious Emissions Below 1GHz		Maximum Conducted Spurious Emissions Above 1GHz		FCC Limit
				Frequency (MHz)	Datum (dBm)	Frequency (MHz)	Datum (dBm)	
FM	25KHz	Middle	464.1250	414.89	-77.87	2066.13	-77.27	-57dBm
Test Results				Compliance				

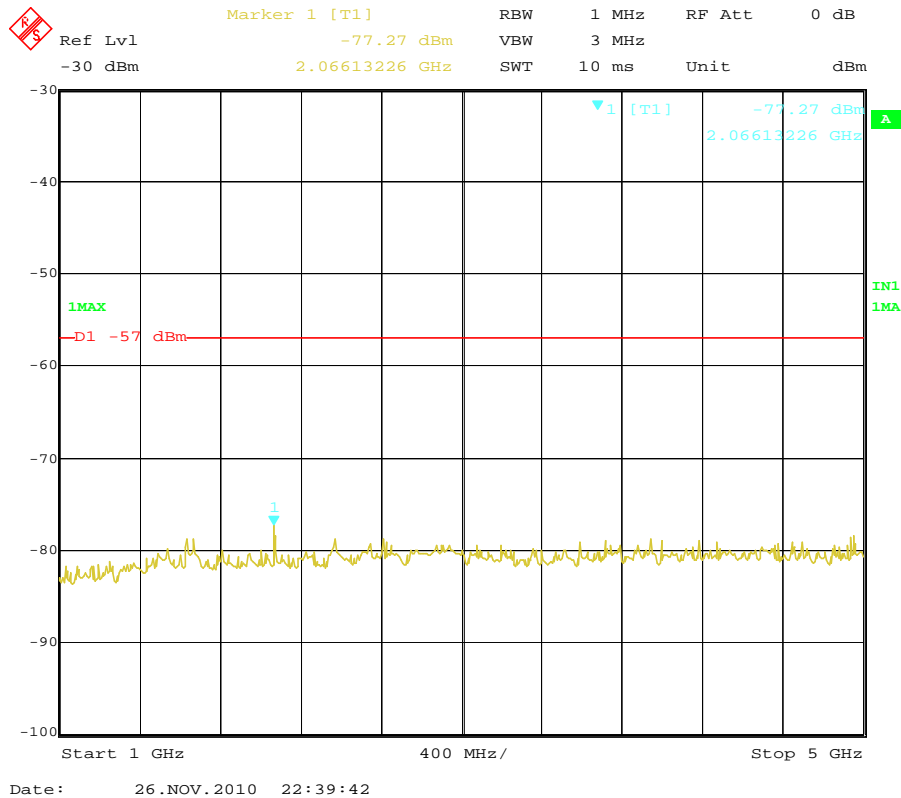
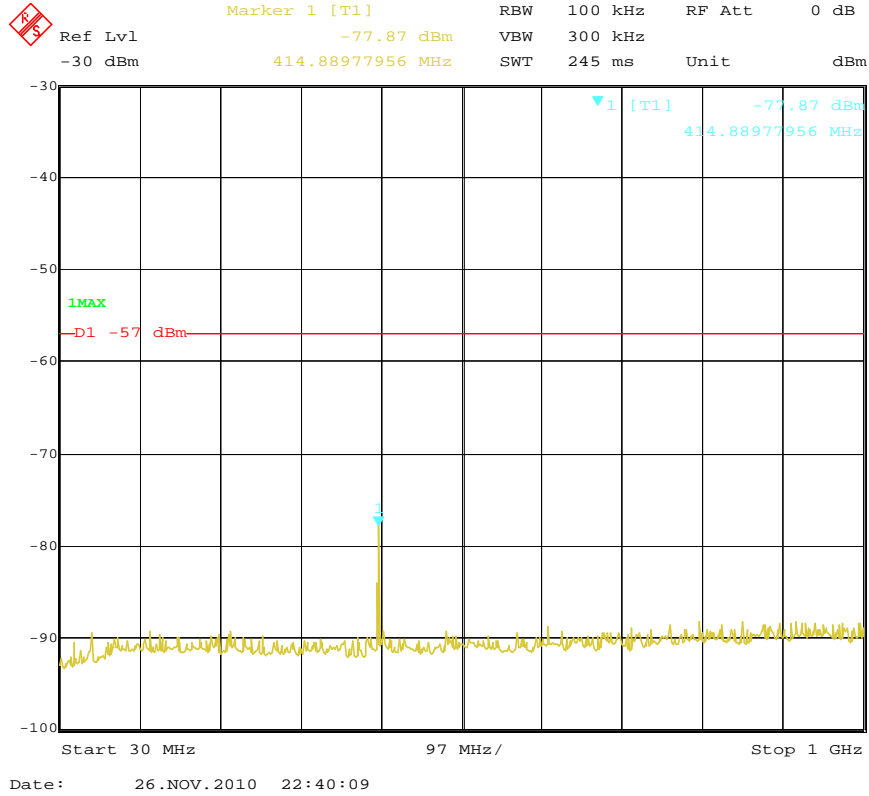

Modulation Type	Channel SpARATION	Test Channel	Test Frequency (MHz)	Maximum Conducted Spurious Emissions Below 1GHz		Maximum Conducted Spurious Emissions Above 1GHz		FCC Limit
				Frequency (MHz)	Datum (dBm)	Frequency (MHz)	Datum (dBm)	
FM	25KHz	High	489.9875	440.16	-74.39	2963.93	-78.83	-57dBm
Test Results				Compliance				

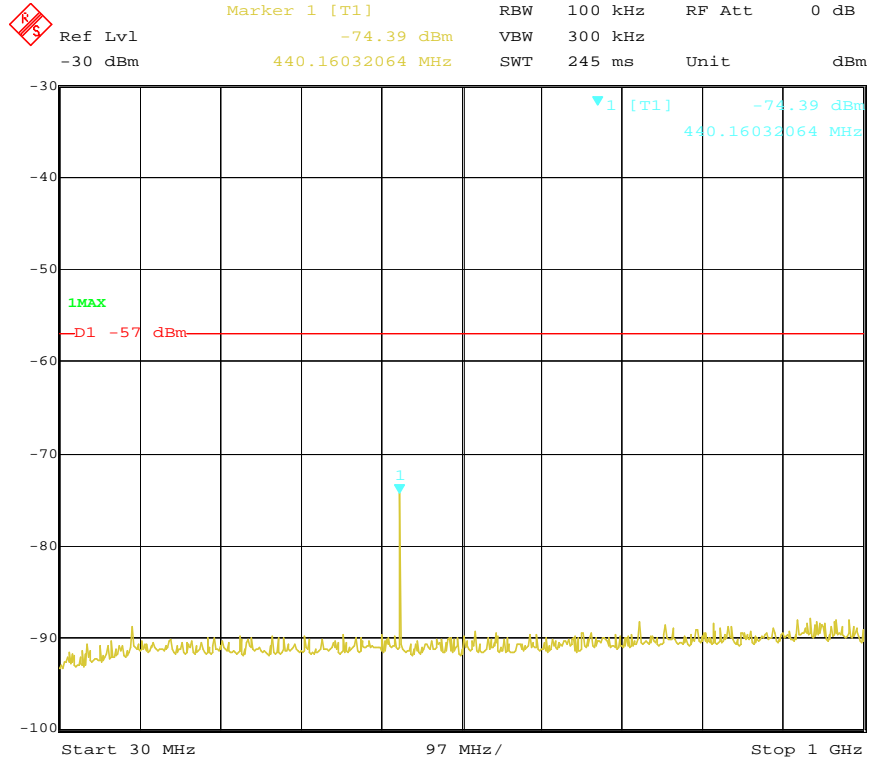

Date: 26.NOV.2010 22:40:27

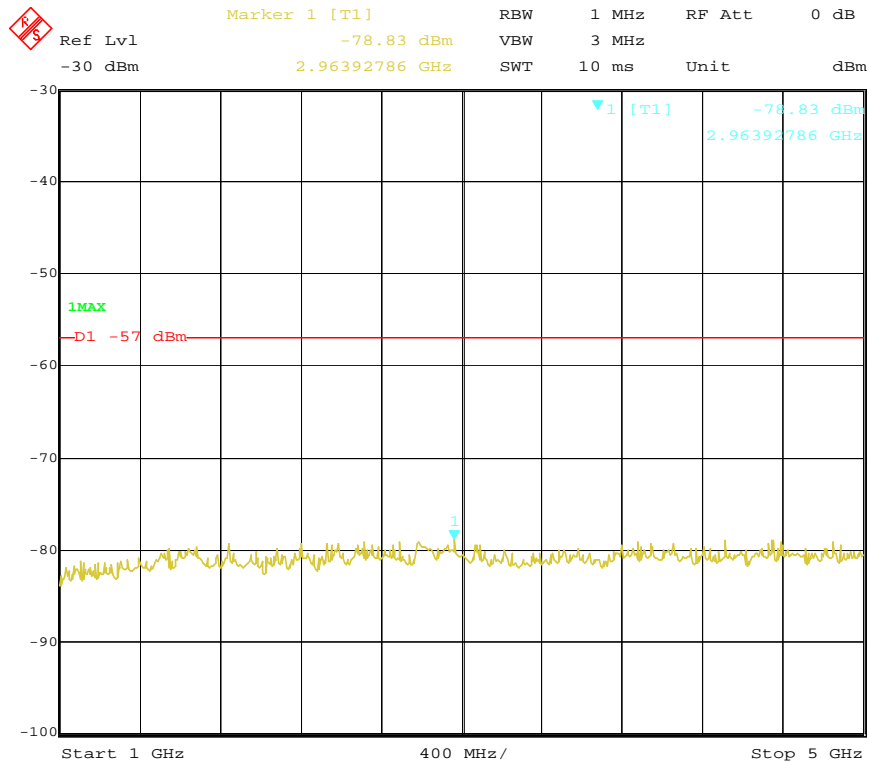

Date: 26.NOV.2010 22:40:49

Modulation Type	Channel SpARATION	Test Channel	Test Frequency (MHz)	Maximum Conducted Spurious Emissions Below 1GHz		Maximum Conducted Spurious Emissions Above 1GHz		FCC Limit
				Frequency (MHz)	Datum (dBm)	Frequency (MHz)	Datum (dBm)	
FM	12.5KHz	Low	438.1250	387.68	-80.85	4470.94	-78.64	-57dBm
Test Results				Compliance				

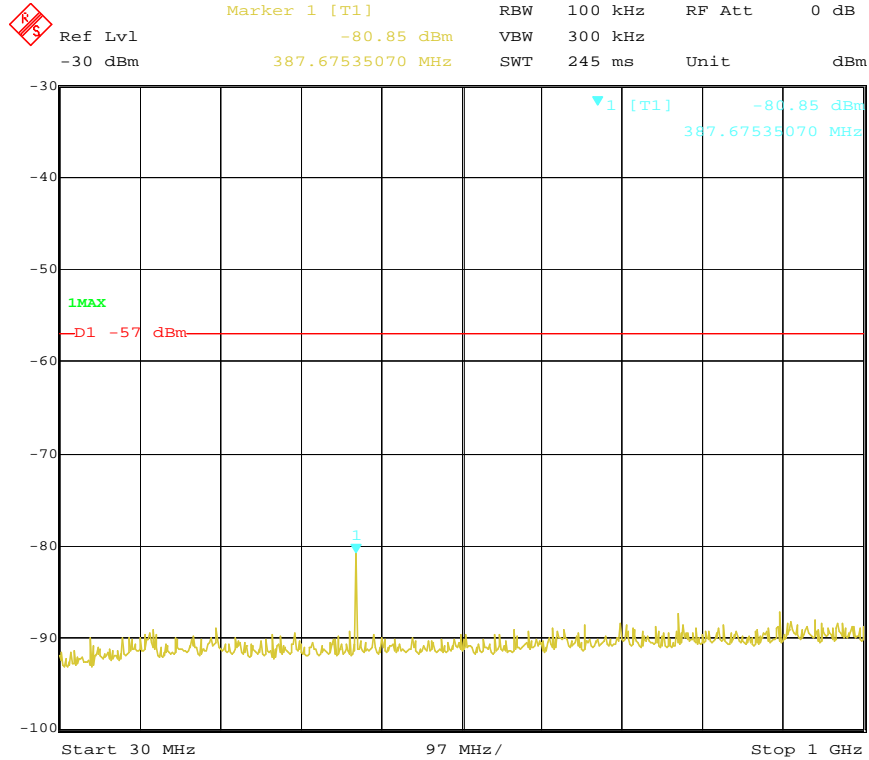

Date: 26.NOV.2010 22:41:26

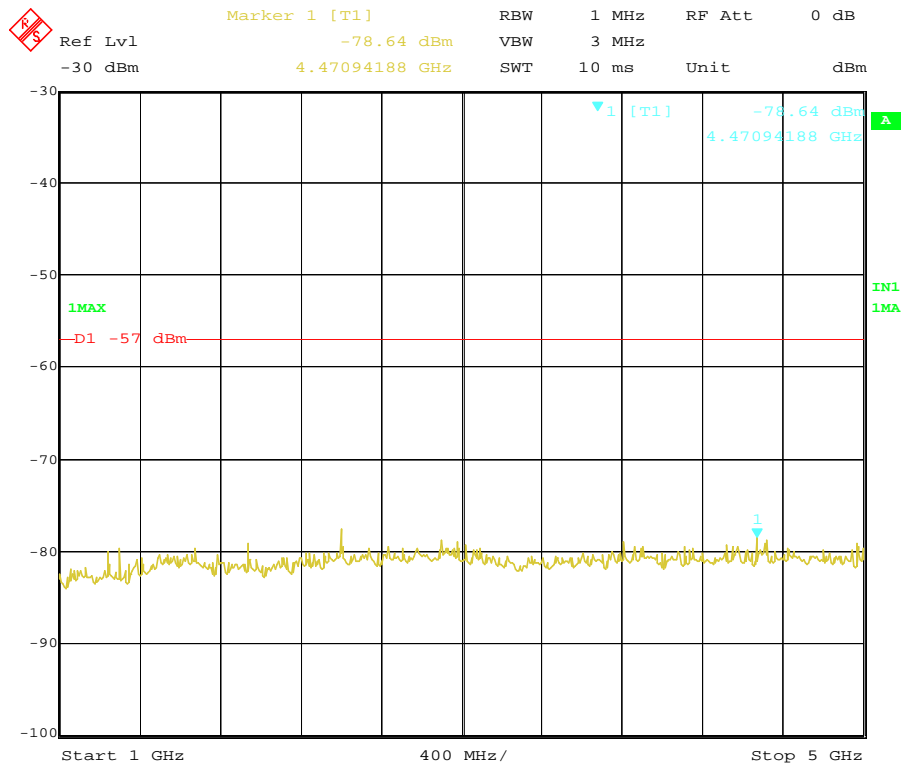

Date: 26.NOV.2010 22:41:05

Modulation Type	Channel SpARATION	Test Channel	Test Frequency (MHz)	Maximum Conducted Spurious Emissions Below 1GHz		Maximum Conducted Spurious Emissions Above 1GHz		FCC Limit
				Frequency (MHz)	Datum (dBm)	Frequency (MHz)	Datum (dBm)	
FM	12.5KHz	Middle	464.1250	414.89	-77.62	2066.13	-77.12	-57dBm
Test Results				Compliance				

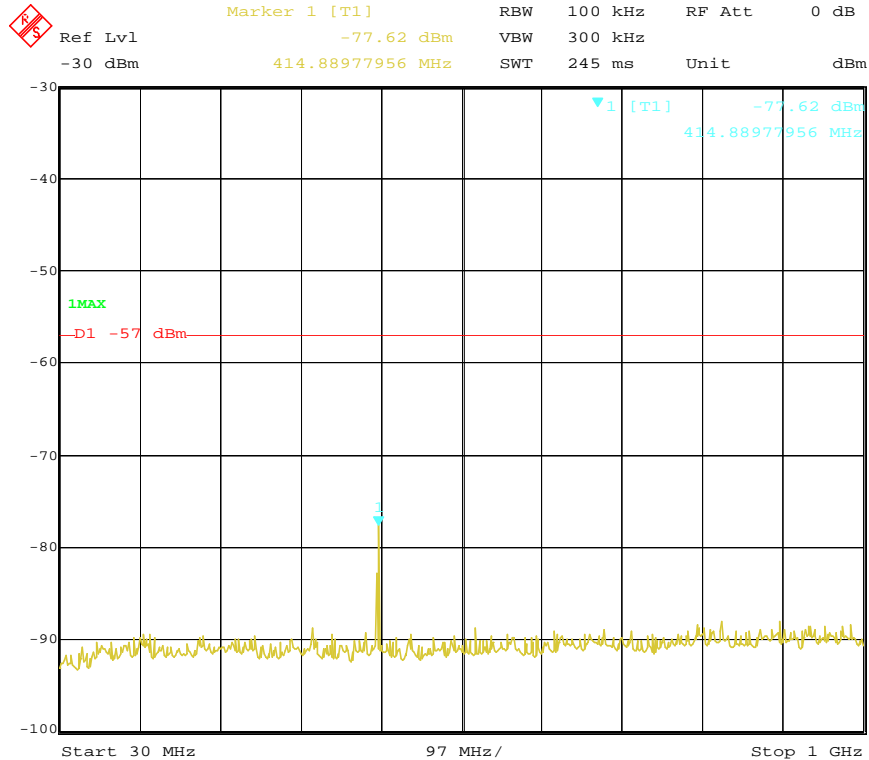

Date: 26.NOV.2010 22:41:40

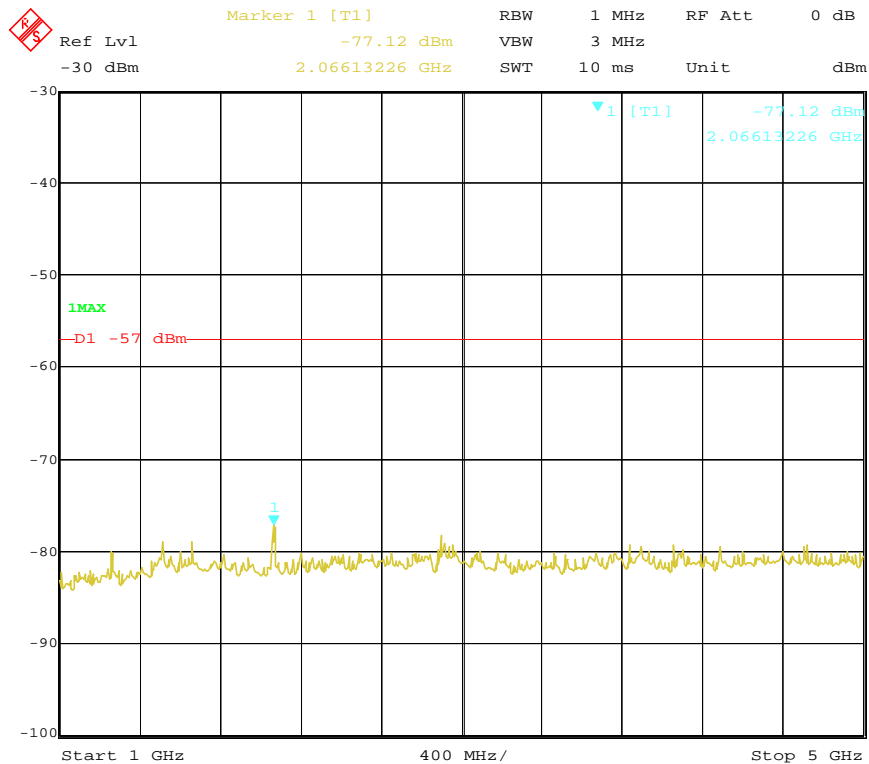

Date: 29.NOV.2010 10:35:46

Modulation Type	Channel SpARATION	Test Channel	Test Frequency (MHz)	Maximum Conducted Spurious Emissions Below 1GHz		Maximum Conducted Spurious Emissions Above 1GHz		FCC Limit
				Frequency (MHz)	Datum (dBm)	Frequency (MHz)	Datum (dBm)	
FM	12.5KHz	High	489.97875	440.16	-74.40	4991.98	-78.45	-57dBm
Test Results				Compliance				

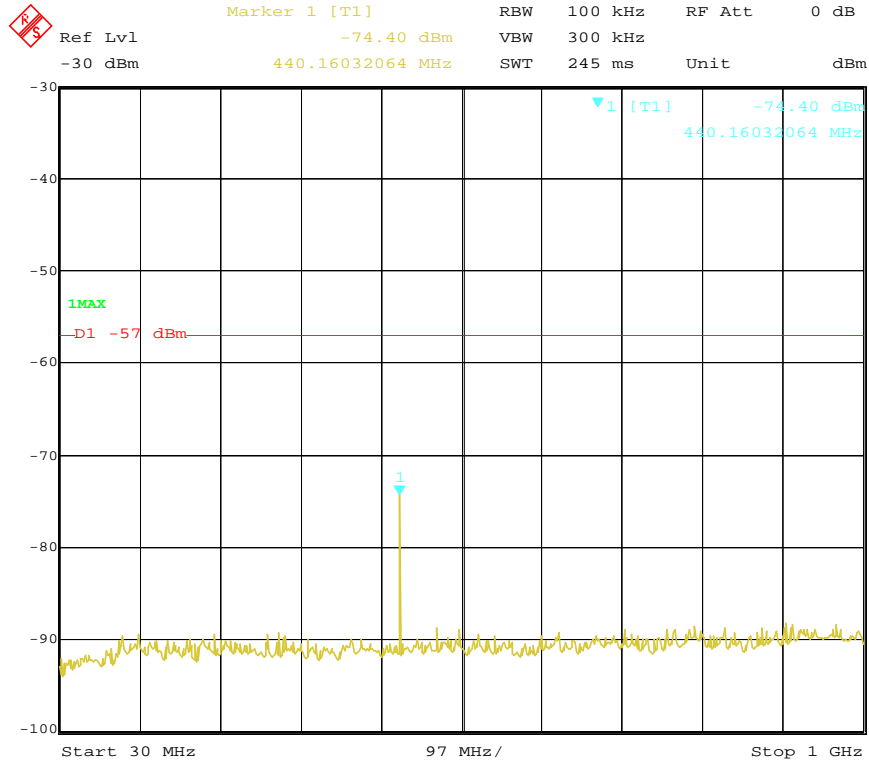

Date: 26.NOV.2010 22:42:44

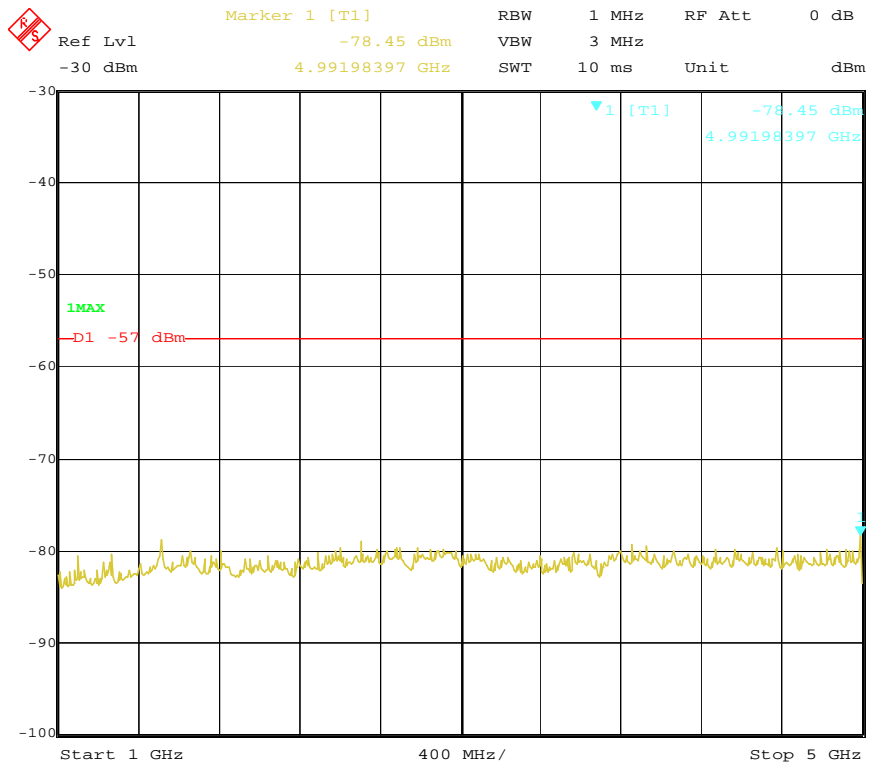

Date: 29.NOV.2010 10:36:14

For IC

Modulation Type	Channel Separation	Test Channel	Test Frequency (MHz)	Maximum Conducted Spurious Emissions Below 1GHz		Maximum Conducted Spurious Emissions Above 1GHz		FCC Limit
				Frequency (MHz)	Datum (dBm)	Frequency (MHz)	Datum (dBm)	
FM	25KHz	Low	450.1250	399.33	-79.38	2947.90	-78.56	-57dBm
Test Results				Compliance				

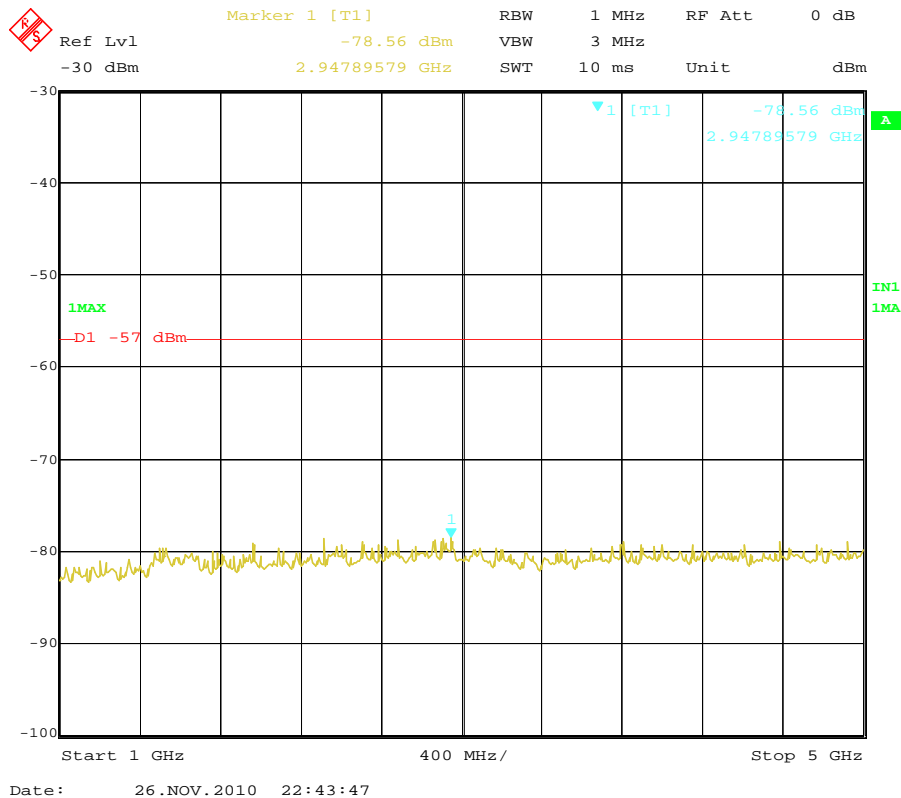
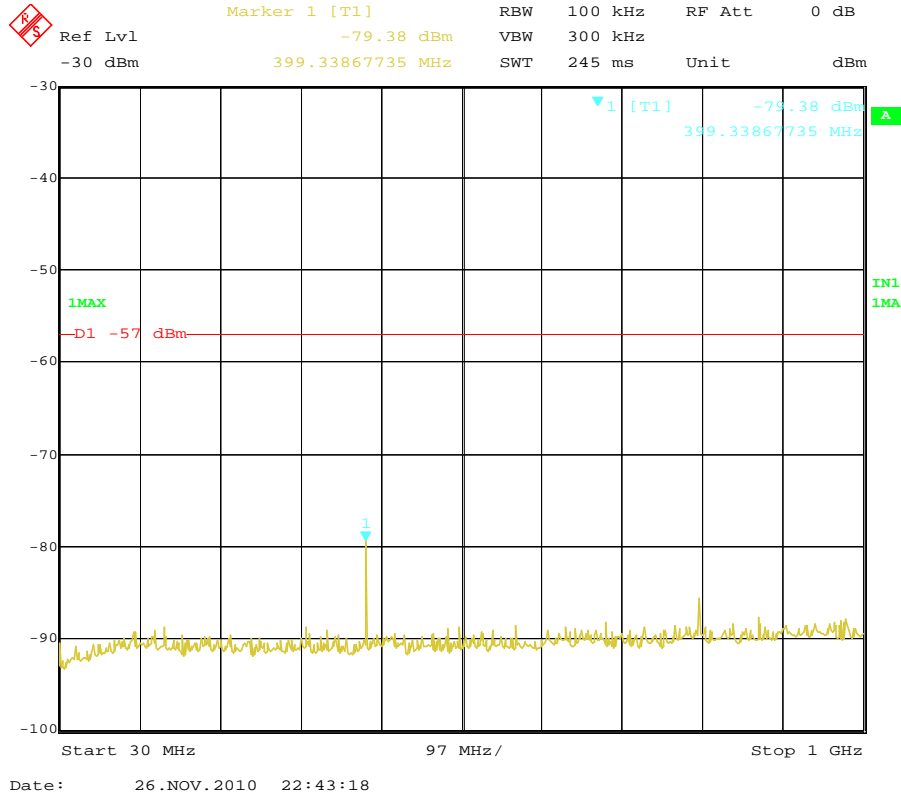

Modulation Type	Channel SpARATION	Test Channel	Test Frequency (MHz)	Maximum Conducted Spurious Emissions Below 1GHz		Maximum Conducted Spurious Emissions Above 1GHz		FCC Limit
				Frequency (MHz)	Datum (dBm)	Frequency (MHz)	Datum (dBm)	
FM	25KHz	Middle	460.1250	409.06	-78.00	4198.40	-78.74	-57dBm
Test Results				Compliance				

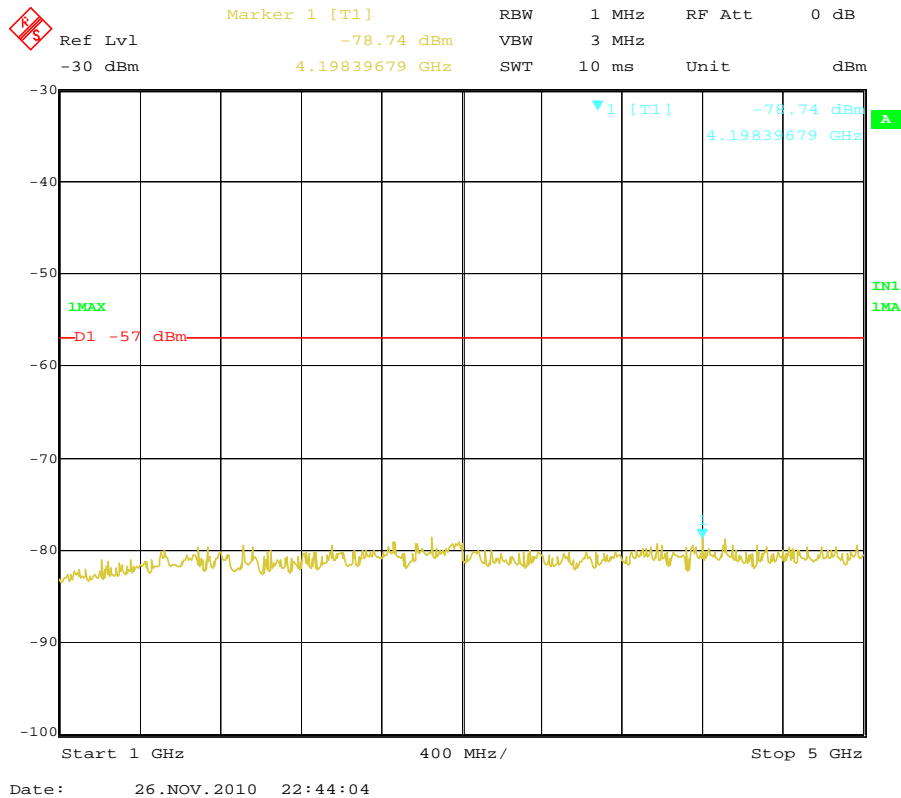
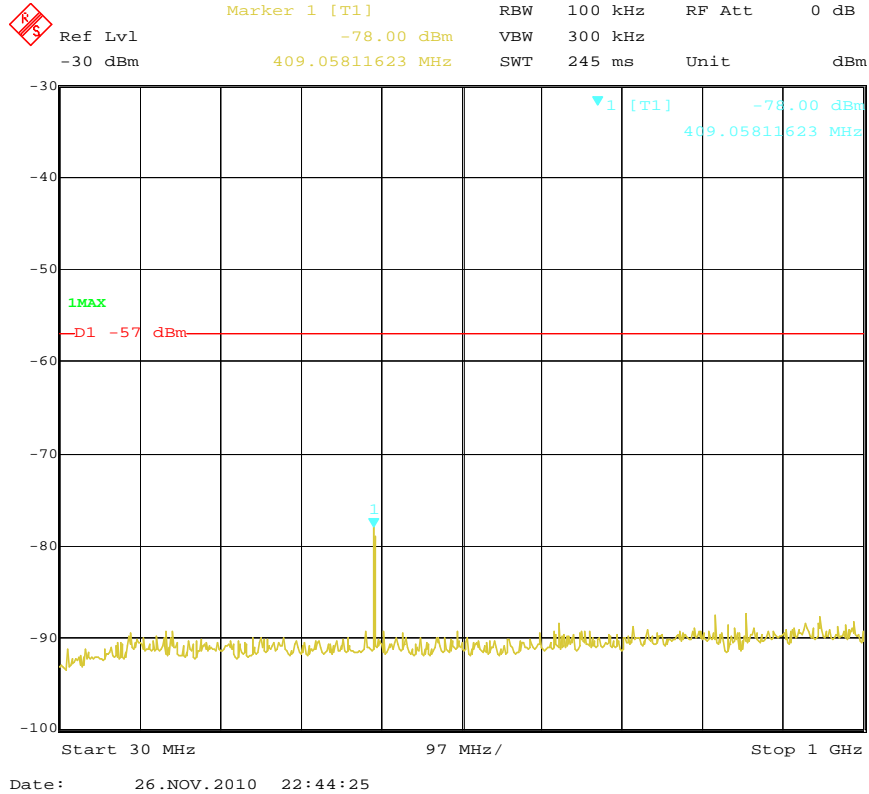

Modulation Type	Channel SpARATION	Test Channel	Test Frequency (MHz)	Maximum Conducted Spurious Emissions Below 1GHz		Maximum Conducted Spurious Emissions Above 1GHz		FCC Limit
				Frequency (MHz)	Datum (dBm)	Frequency (MHz)	Datum (dBm)	
FM	25KHz	High	469.9875	420.72	-76.91	2098.20	-75.84	-57dBm
Test Results				Compliance				

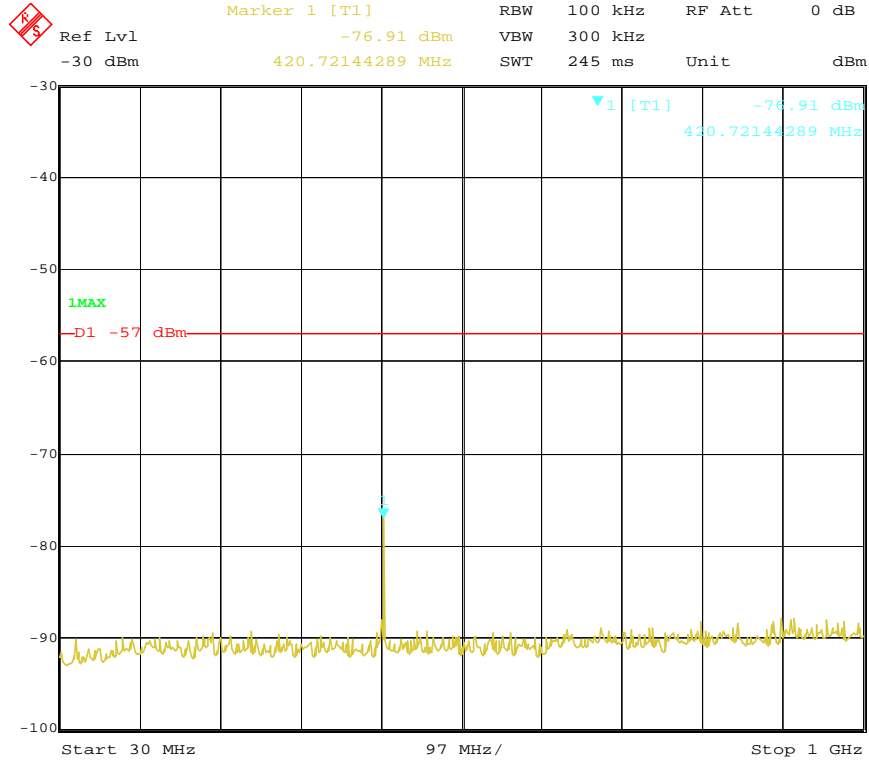

Date: 26.NOV.2010 22:44:40

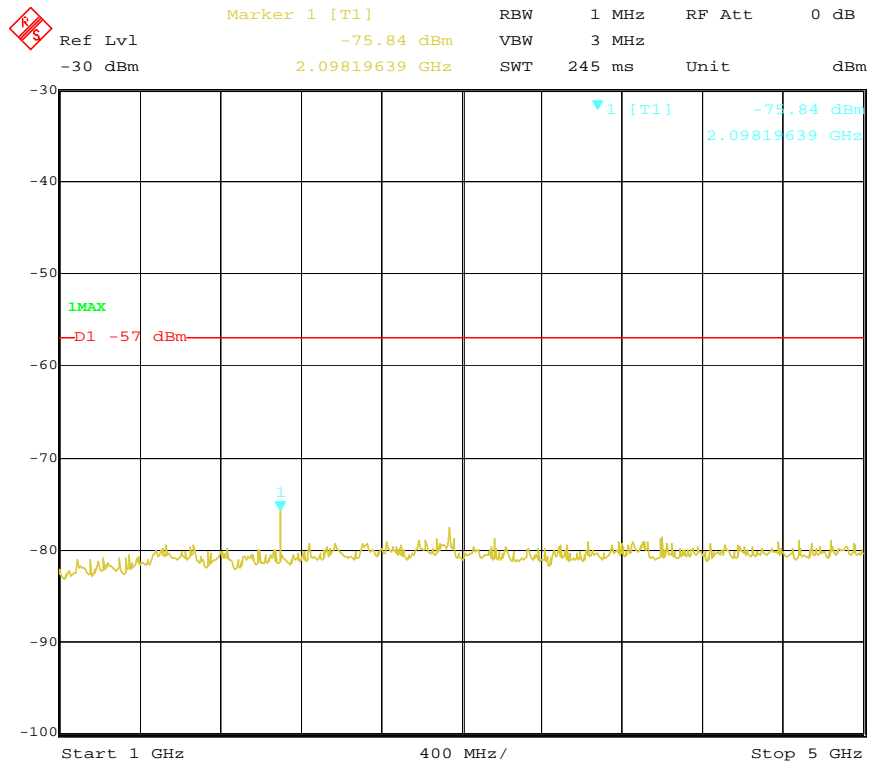

Date: 26.NOV.2010 22:45:02

Modulation Type	Channel SpARATION	Test Channel	Test Frequency (MHz)	Maximum Conducted Spurious Emissions Below 1GHz		Maximum Conducted Spurious Emissions Above 1GHz		FCC Limit
				Frequency (MHz)	Datum (dBm)	Frequency (MHz)	Datum (dBm)	
FM	12.5KHz	Low	450.1250	399.34	-79.60	4663.33	-78.58	-57dBm
Test Results				Compliance				

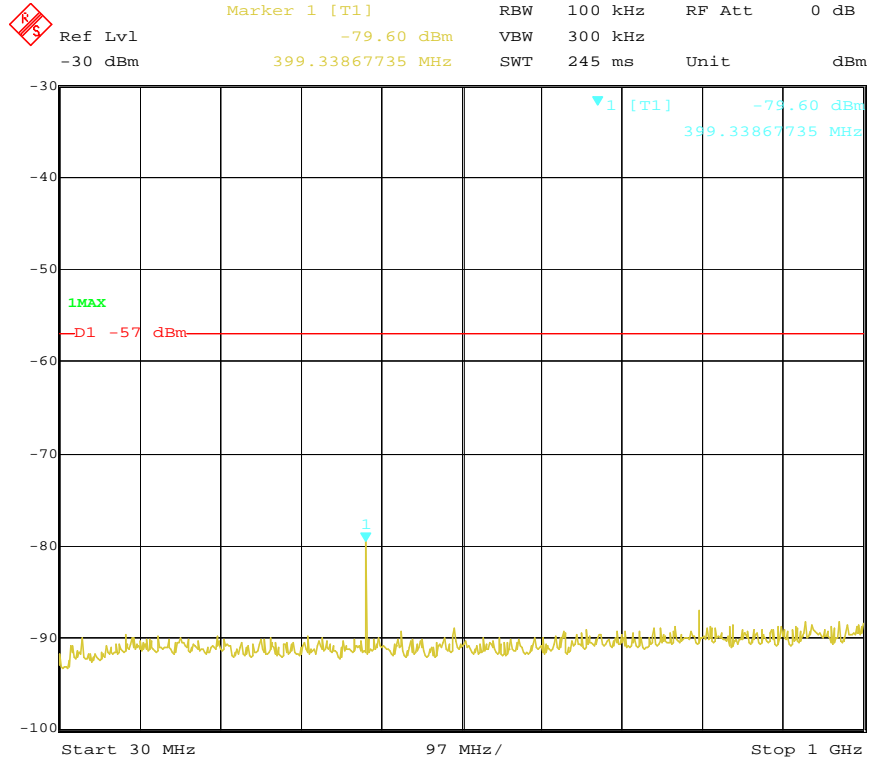

Date: 26.NOV.2010 22:45:37

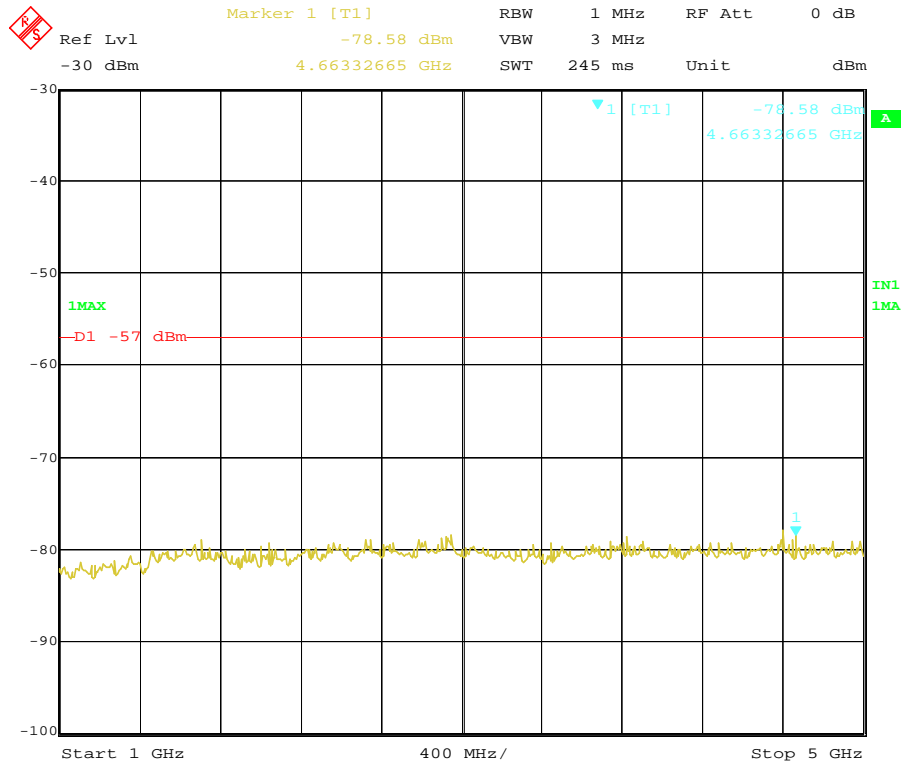

Date: 26.NOV.2010 22:45:17

Modulation Type	Channel SpARATION	Test Channel	Test Frequency (MHz)	Maximum Conducted Spurious Emissions Below 1GHz		Maximum Conducted Spurious Emissions Above 1GHz		FCC Limit
				Frequency (MHz)	Datum (dBm)	Frequency (MHz)	Datum (dBm)	
FM	12.5KHz	Middle	460.1250	409.06	-78.07	3805.61	-77.37	-57dBm
Test Results				Compliance				

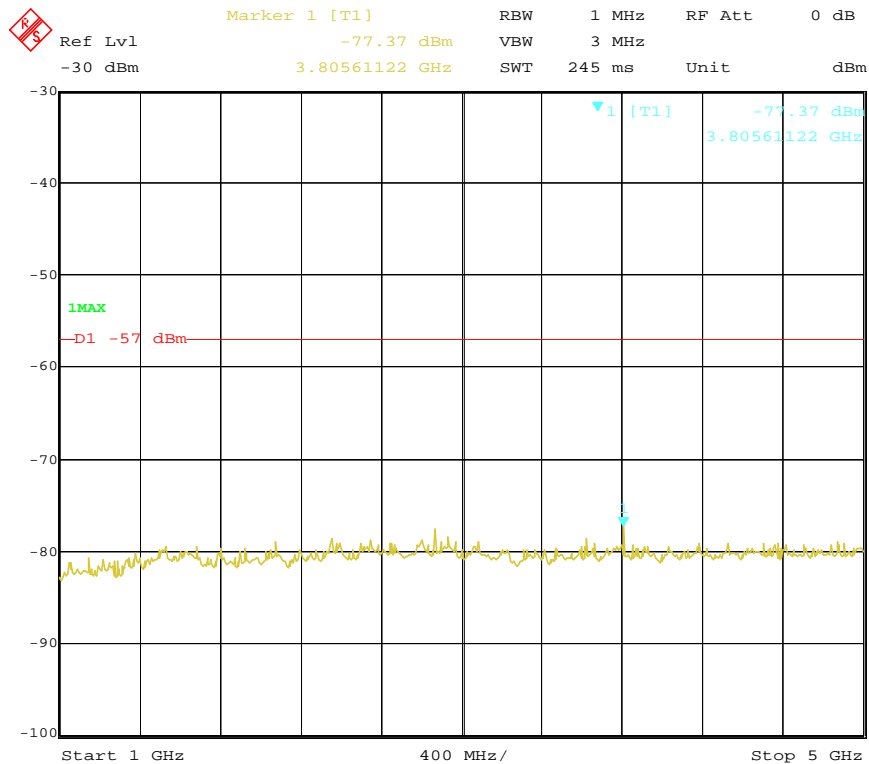
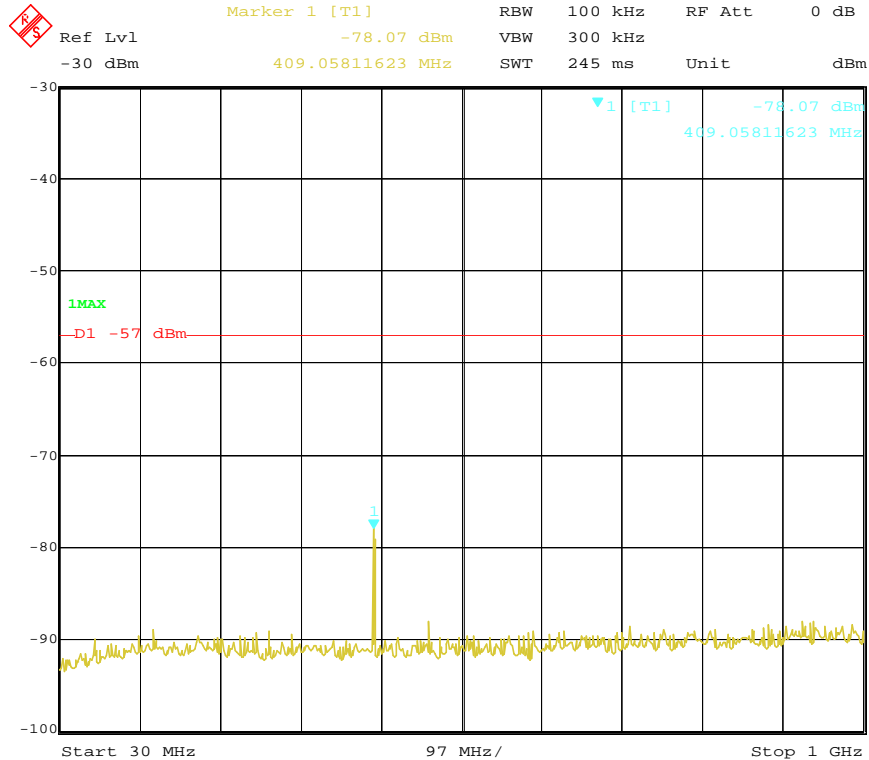

Modulation Type	Channel SpARATION	Test Channel	Test Frequency (MHz)	Maximum Conducted Spurious Emissions Below 1GHz		Maximum Conducted Spurious Emissions Above 1GHz		FCC Limit
				Frequency (MHz)	Datum (dBm)	Frequency (MHz)	Datum (dBm)	
FM	12.5KHz	High	469.97875	420.72	-76.95	20.98.20	-75.48	-57dBm
Test Results				Compliance				

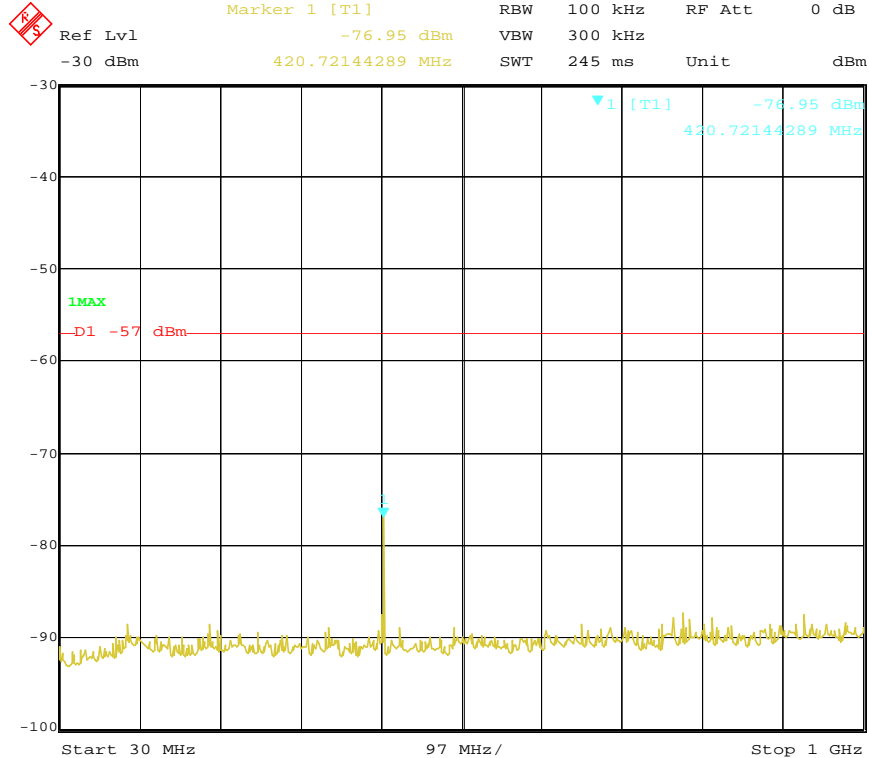

Date: 26.NOV.2010 22:47:03

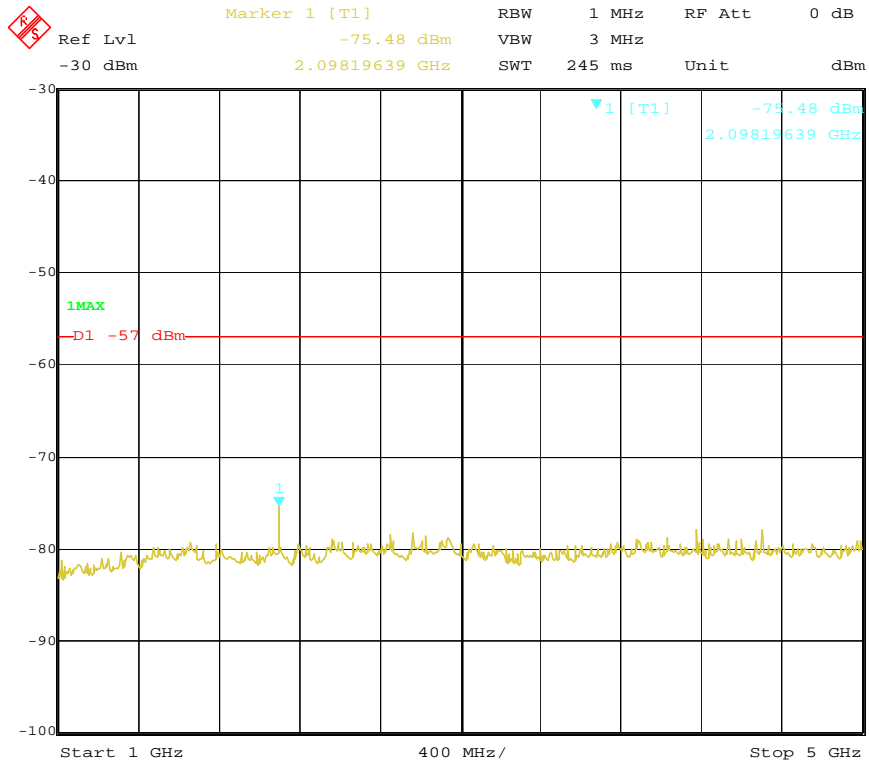

Date: 26.NOV.2010 22:46:43

4.11. RF Exposure Evaluation

Applicable Standard

According to §1.1307(b)(1) and RSS-102, systems operating under the provisions of this section shall be operated in a manner that ensures that the public is not exposed to radio frequency energy level in excess of the Commission's guidelines.

According to §1.1310 and §2.1091 and RSS-102 RF exposure is calculated.

LIMIT

Limits for Maximum Permissible Exposure (MPE)/Controlled Exposure

Frequency Range(MHz)	Electric Field Strength(V/m)	Magnetic Field Strength(A/m)	Power Density (mW/cm ²)	Averaging Time (minute)
Limits for Occupational/Controlled Exposure				
0.3 – 3.0	614	1.63	(100) *	6
3.0 – 30	1842/f	4.89/f	(900/f)*	6
30 – 300	61.4	0.163	1.0	6
300 – 1500	/	/	f/300	6
1500 – 100,000	/	/	5	6

Limits for Maximum Permissible Exposure (MPE)/Uncontrolled Exposure

Frequency Range(MHz)	Electric Field Strength(V/m)	Magnetic Field Strength(A/m)	Power Density (mW/cm ²)	Averaging Time (minute)
Limits for Occupational/Controlled Exposure				
0.3 – 3.0	614	1.63	(100) *	30
3.0 – 30	824/f	2.19/f	(180/f)*	30
30 – 300	27.5	0.073	0.2	30
300 – 1500	/	/	f/1500	30
1500 – 100,000	/	/	1.0	30

F=frequency in MHz

*=Plane-wave equivalent power density

MPE Calculation Method

Predication of MPE limit at a given distance

Equation from page 18 of OET Bulletin 65, Edition 97-01

$$S = PG / 4\pi R^2$$

Where: S=power density

P=power input to antenna

G=power gain of the antenna in the direction of interest relative to an isotropic radiator

R=distance to the center of radiation of the antenna

As declared by the Applicant, the EUT transmits with the maximum soure-baed Duty Cycle of 50%-see the User manual, and the EUT is a wireless device used in a mobile application, at least 108cm from any body part of the user or nearby persons; from the peak EUT RF output power, the minimum mobile separation distance, d=108cm, as well as the gain of the used antenna is 3dBi, the RF power density can be obtained.

TEST RESULTS

For FCC

For Rated High Power (25Watt)

For 25 KHz Channel Spacing

Frequency (MHz)	Minimum Separation Distance (cm)	Output Power (dBm)	Output Power (mW)	Antenna Gain (Nemeric)	Power Density Limit (mW/cm ²)	Power Density At 108 cm (mW/cm ²)	Test Results
438.1250	108.00	43.11	22464.40	1.995	1.4604	0.2786	Compliance
464.1250	108.00	43.50	22387.20	1.995	1.5471	0.3047	Compliance
489.9875	108.00	43.38	21777.10	1.995	1.6333	0.2964	Compliance

For 12.5 KHz Channel Spacing

Frequency (MHz)	Minimum Separation Distance (cm)	Output Power (dBm)	Output Power (mW)	Antenna Gain (Nemeric)	Power Density Limit (mW/cm ²)	Power Density At 108 cm (mW/cm ²)	Test Results
438.1250	108.00	43.11	20464.40	1.995	1.4604	0.2786	Compliance
464.1250	108.00	43.52	22490.50	1.995	1.5471	0.3062	Compliance
489.9875	108.00	43.38	21777.10	1.995	1.6333	0.2964	Compliance

For Rated Low Power (5Watt)**For 25 KHz Channel Spacing**

Frequency (MHz)	Minimum Separation Distance (cm)	Output Power (dBm)	Output Power (mW)	Antenna Gain (Nemeric)	Power Density Limit (mW/cm ²)	Power Density At 108 cm (mW/cm ²)	Test Results
438.1250	108.00	36.94	4943.10	1.995	1.4604	0.0673	Compliance
464.1250	108.00	37.50	4623.40	1.995	1.5471	0.0765	Compliance
489.9875	108.00	37.26	5321.10	1.995	1.6333	0.0724	Compliance

For 12.5 KHz Channel Spacing

Frequency (MHz)	Minimum Separation Distance (cm)	Output Power (dBm)	Output Power (mW)	Antenna Gain (Nemeric)	Power Density Limit (mW/cm ²)	Power Density At 108 cm (mW/cm ²)	Test Results
438.1250	108.00	36.98	4988.80	1.995	1.4604	0.0679	Compliance
464.1250	108.00	37.45	5559.00	1.995	1.5471	0.0757	Compliance
489.9875	108.00	37.34	5420.00	1.995	1.6333	0.0738	Compliance

For IC**For Rated High Power (25Watt)****For 25 KHz Channel Spacing**

Frequency (MHz)	Minimum Separation Distance (cm)	Output Power (dBm)	Output Power (mW)	Antenna Gain (Nemeric)	Power Density Limit (mW/cm ²)	Power Density At 108 cm (mW/cm ²)	Test Results
450.1250	108.00	43.35	21627.20	1.995	1.5004	0.2944	Compliance
460.1250	108.00	43.50	22387.20	1.995	1.5334	0.3047	Compliance
469.9875	108.00	43.51	22438.80	1.995	1.5666	0.3055	Compliance

For 12.5 KHz Channel Spacing

Frequency (MHz)	Minimum Separation Distance (cm)	Output Power (dBm)	Output Power (mW)	Antenna Gain (Nemeric)	Power Density Limit (mW/cm ²)	Power Density At 108 cm (mW/cm ²)	Test Results
450.1250	108.00	43.34	21577.40	1.995	1.5004	0.2937	Compliance
460.1250	108.00	43.51	22438.80	1.995	1.5334	0.3055	Compliance
469.9875	108.00	43.53	22542.40	1.995	1.5666	0.3069	Compliance

For Rated Low Power (5Watt)**For 25 KHz Channel Spacing**

Frequency (MHz)	Minimum Separation Distance (cm)	Output Power (dBm)	Output Power (mW)	Antenna Gain (Nemeric)	Power Density Limit (mW/cm ²)	Power Density At 108 cm (mW/cm ²)	Test Results
450.1250	108.00	37.19	5236.00	1.995	1.5004	0.0713	Compliance
460.1250	108.00	37.42	5520.80	1.995	1.5334	0.0752	Compliance
469.9875	108.00	37.39	5482.80	1.995	1.5666	0.0746	Compliance

For 12.5 KHz Channel Spacing

Frequency (MHz)	Minimum Separation Distance (cm)	Output Power (dBm)	Output Power (mW)	Antenna Gain (Nemeric)	Power Density Limit (mW/cm ²)	Power Density At 108 cm (mW/cm ²)	Test Results
450.1250	108.00	37.18	5224.00	1.995	1.5004	0.0711	Compliance
460.1250	108.00	37.44	5546.30	1.995	1.5334	0.0755	Compliance
469.9875	108.00	37.45	5559.00	1.995	1.5666	0.0757	Compliance

5. Test Setup Photos of the EUT

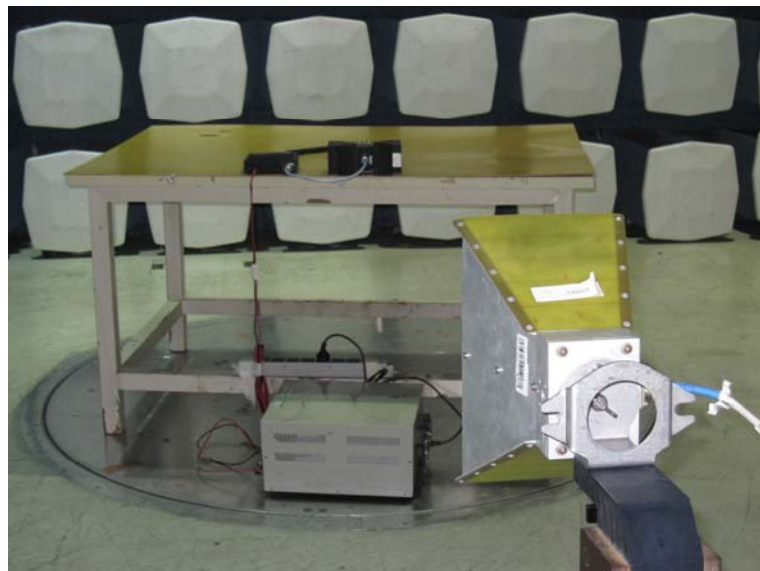

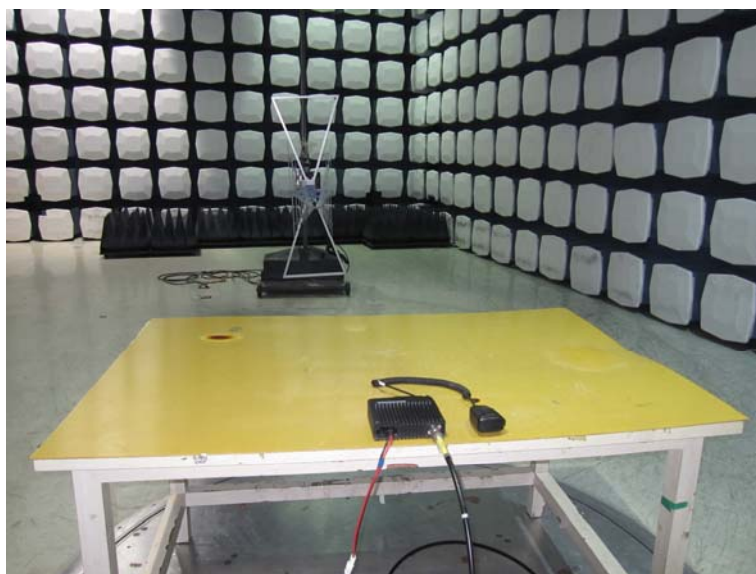
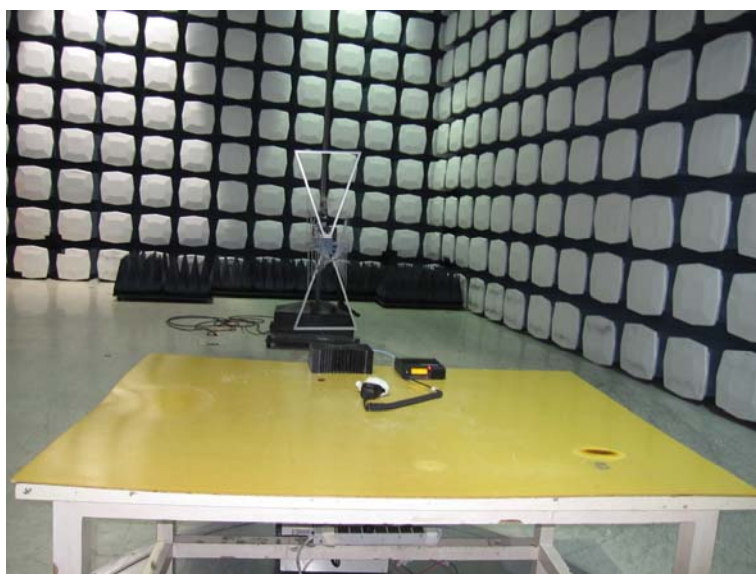
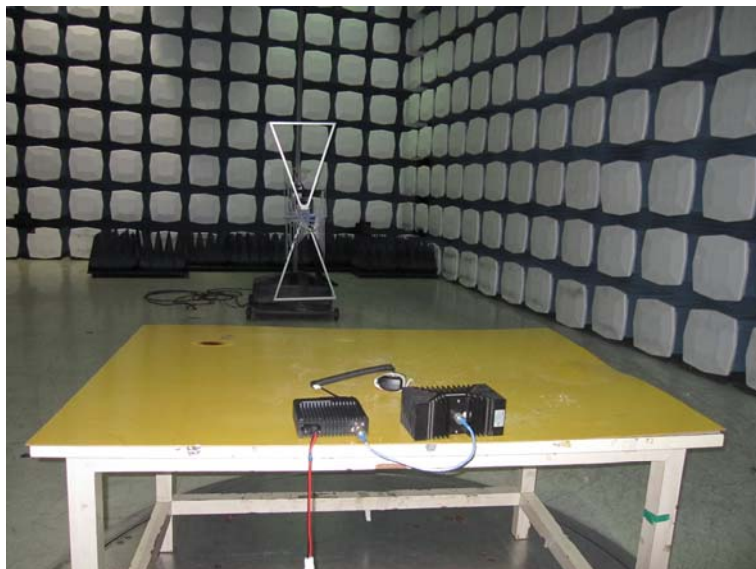

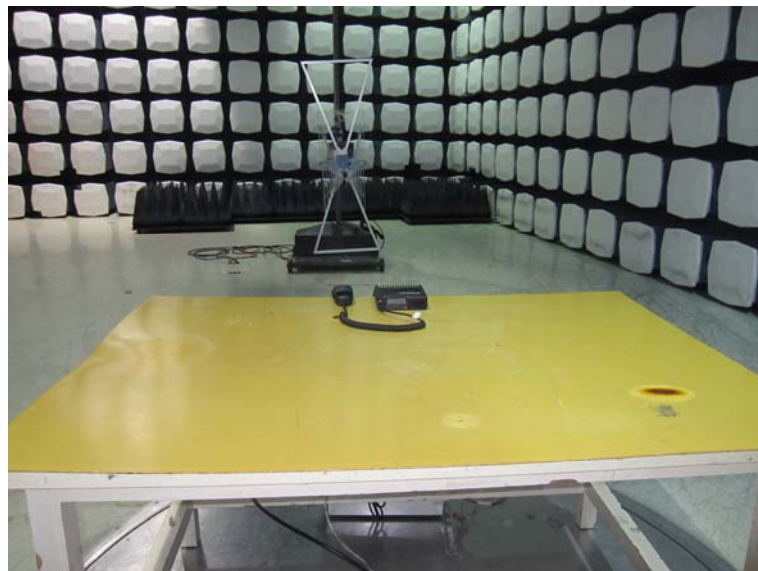

6. External and Internal Photos of the EUT

External Photos







Internal Photos

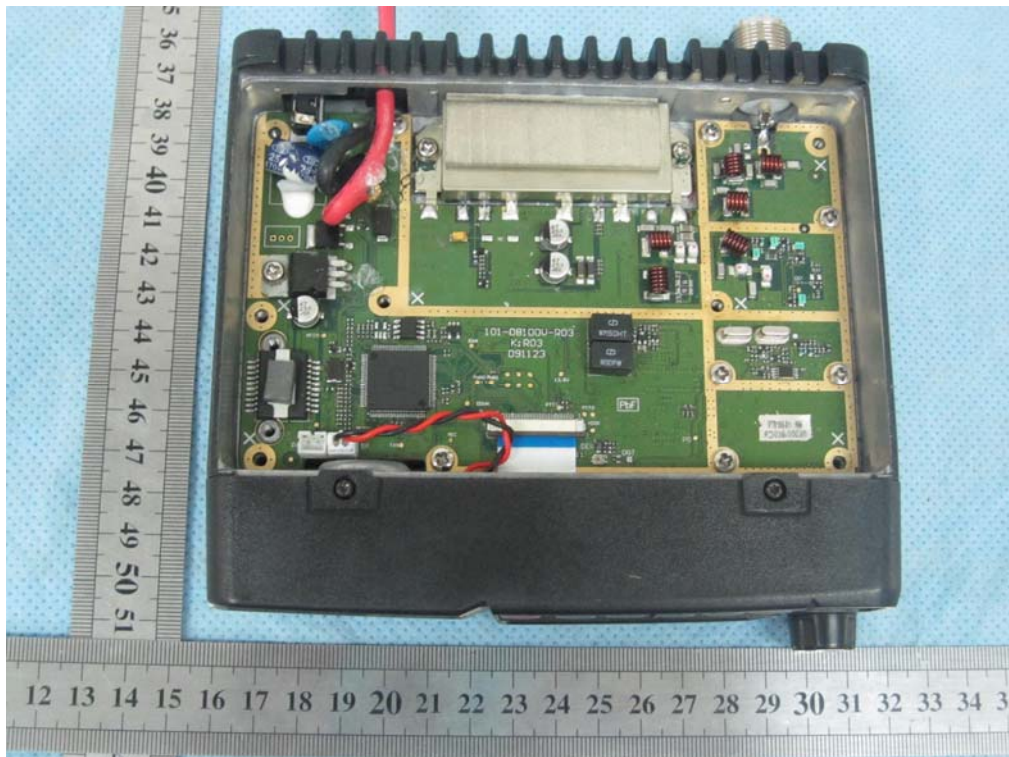
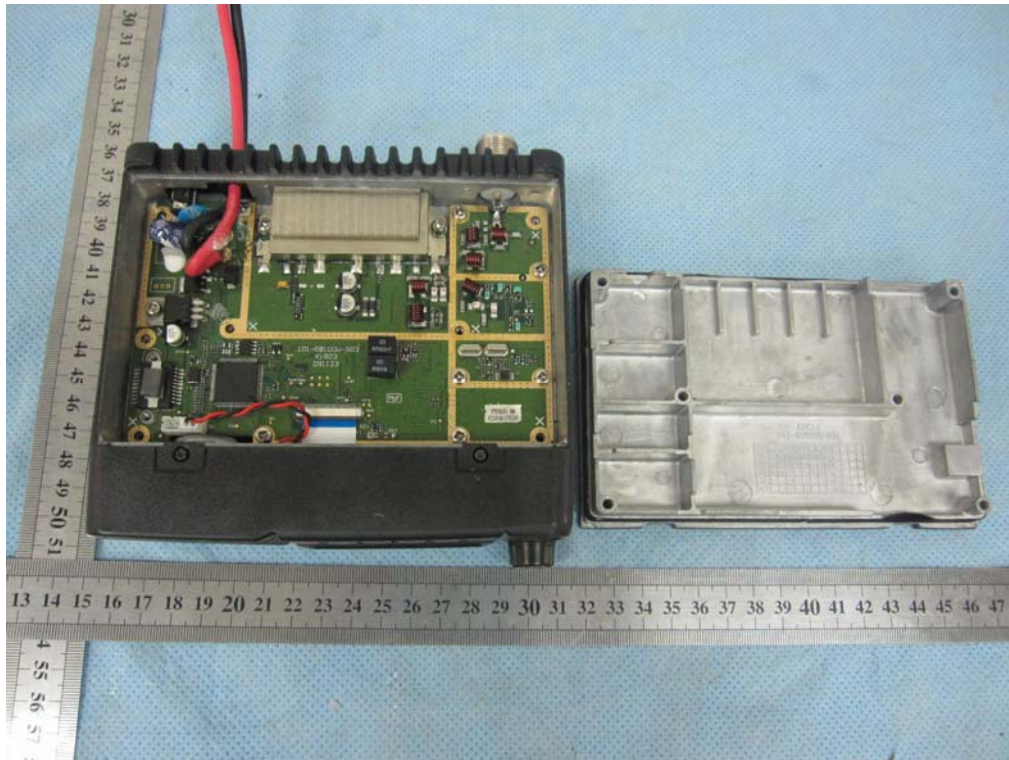

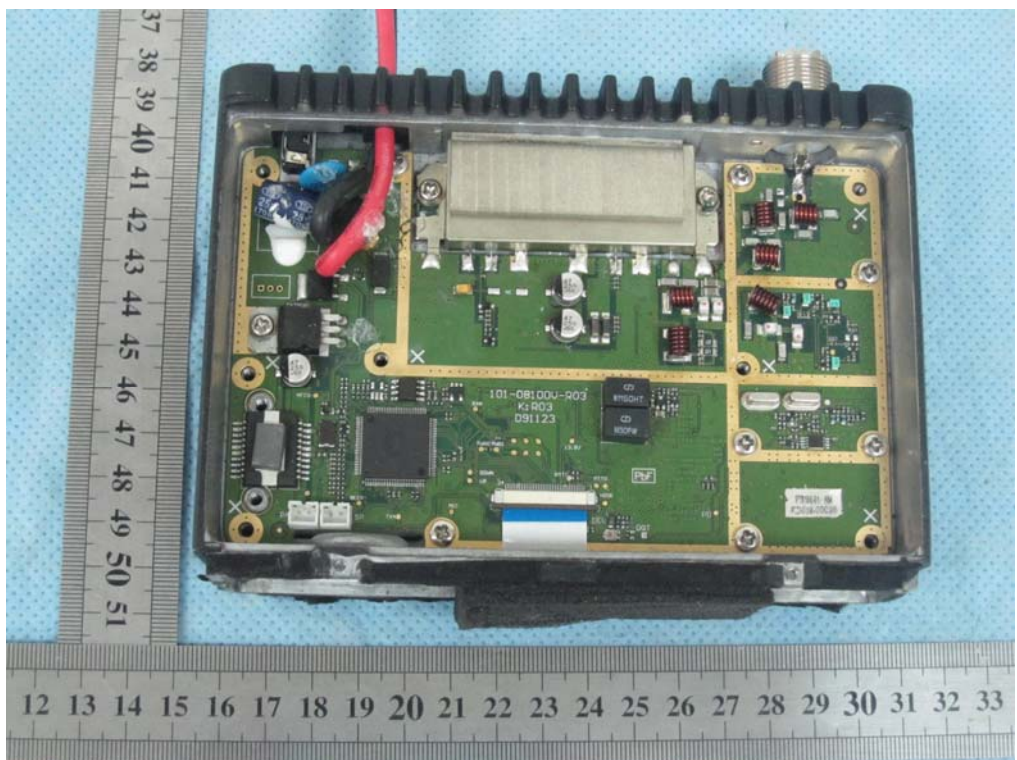
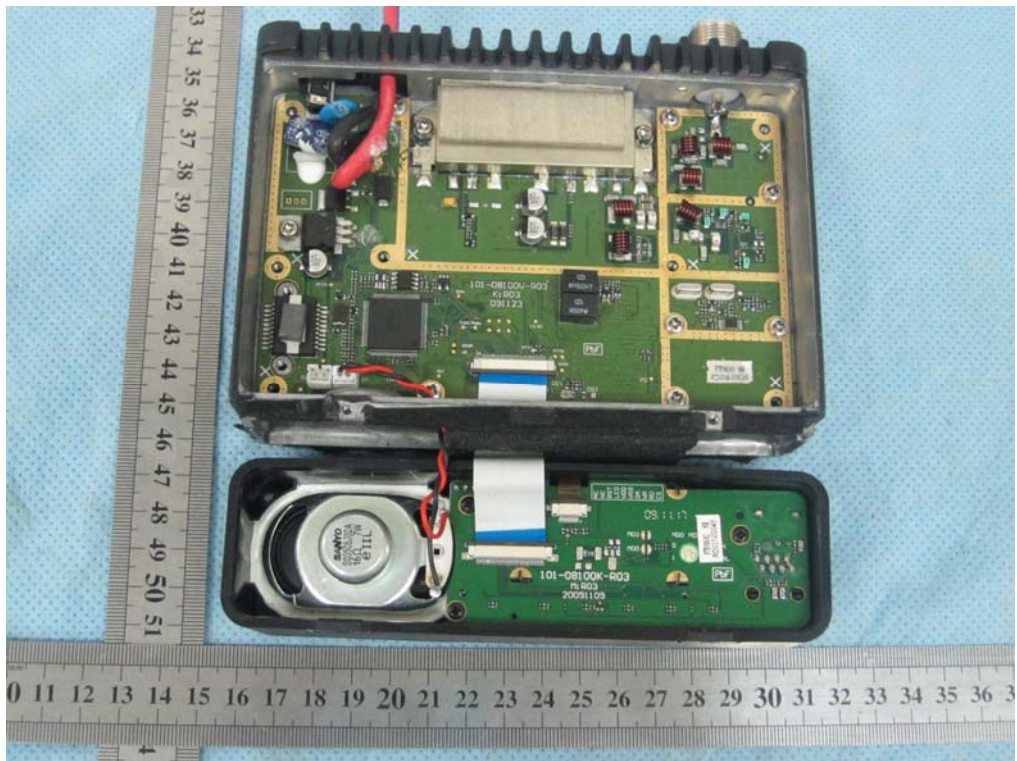

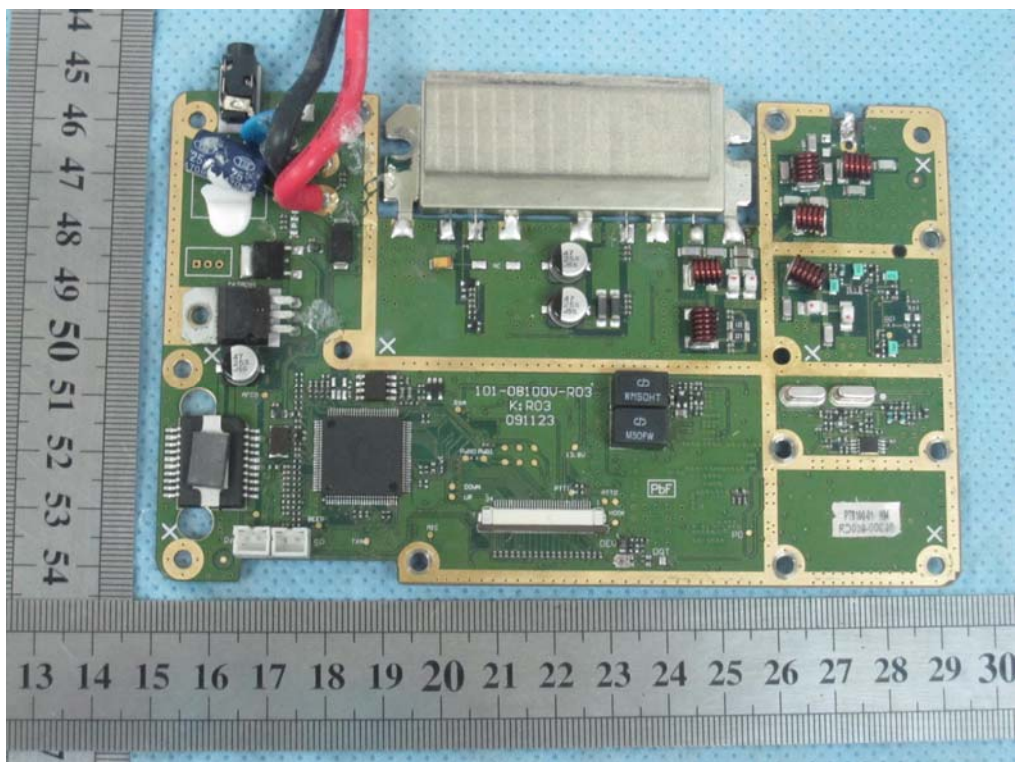
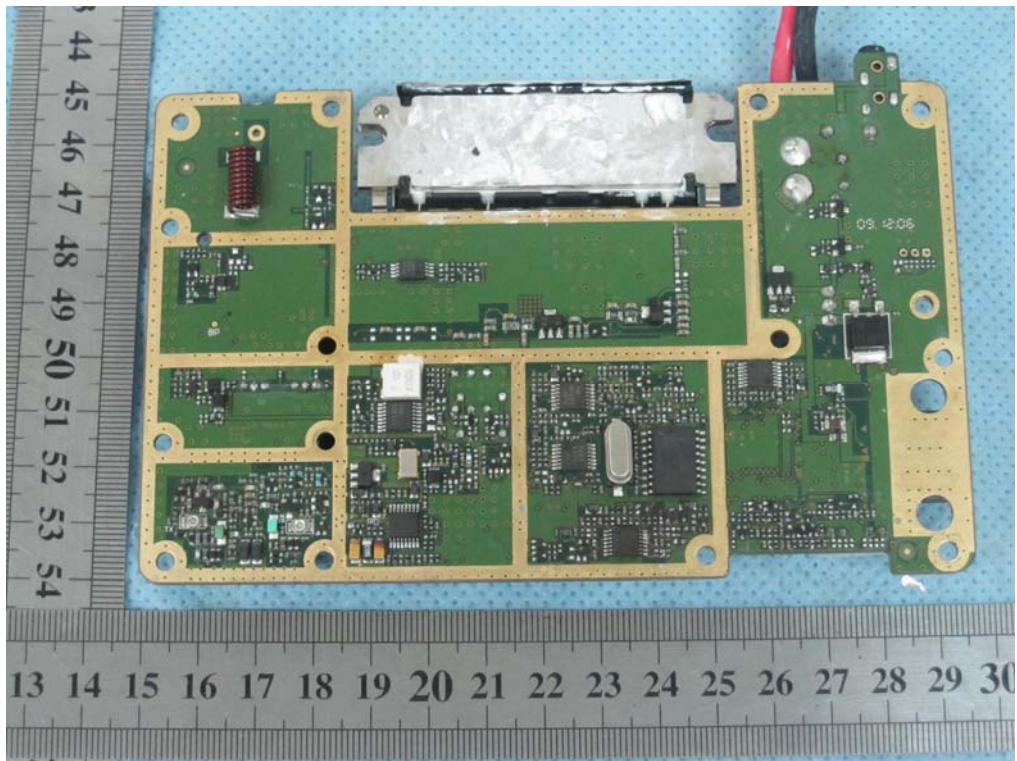

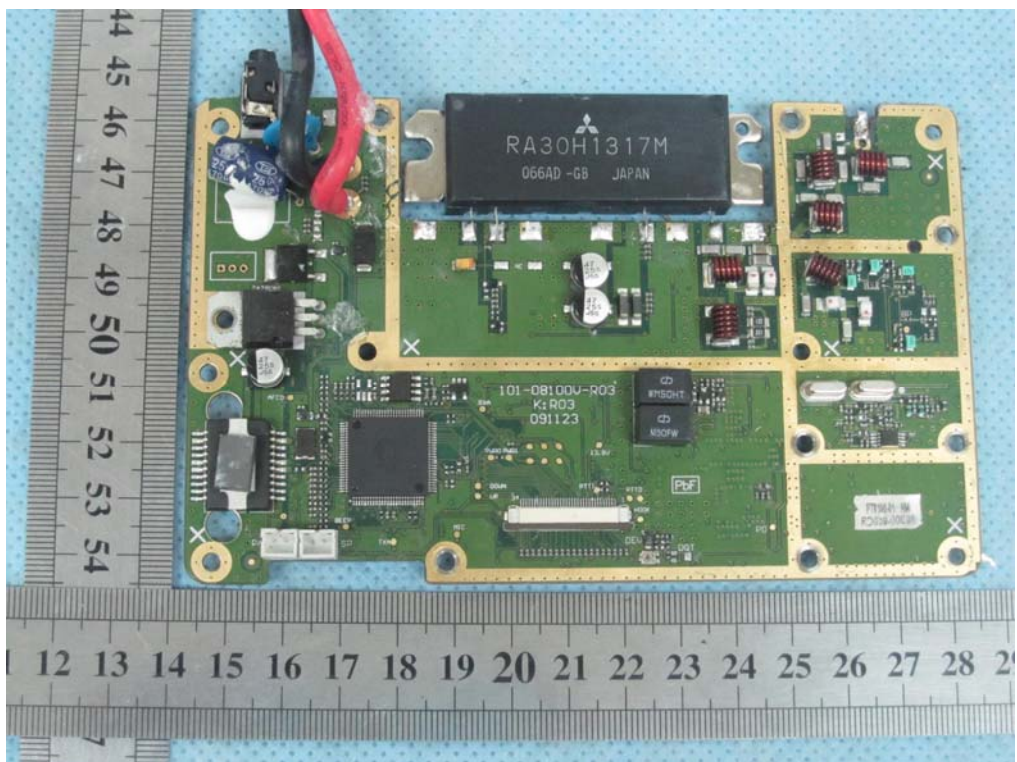
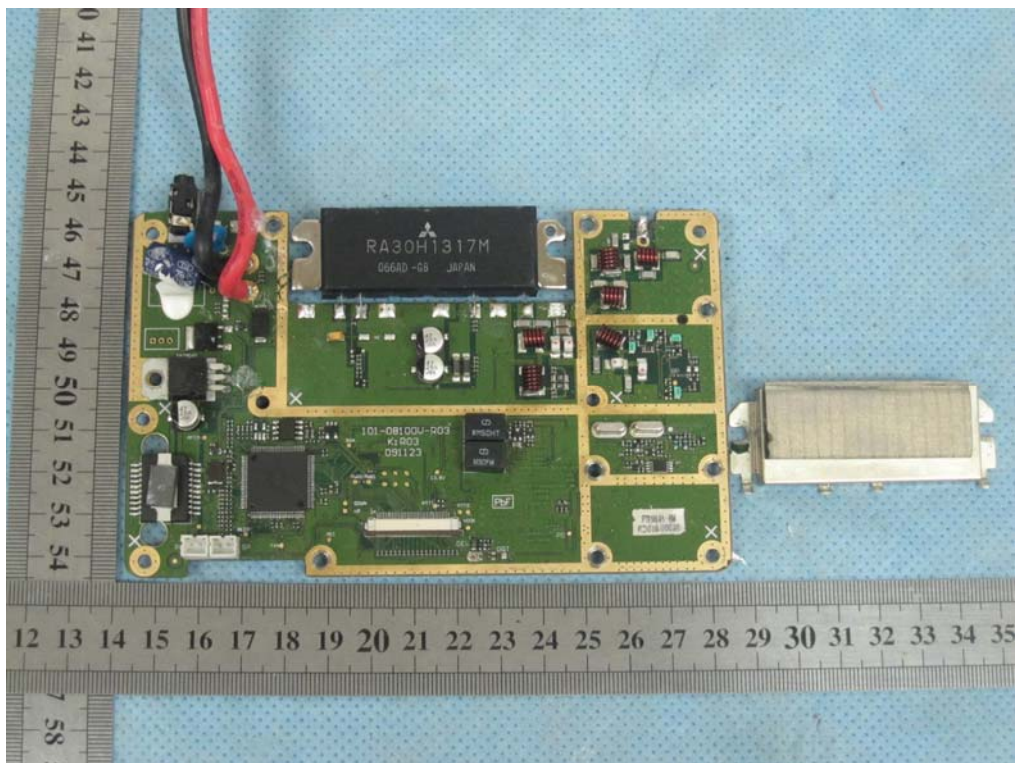



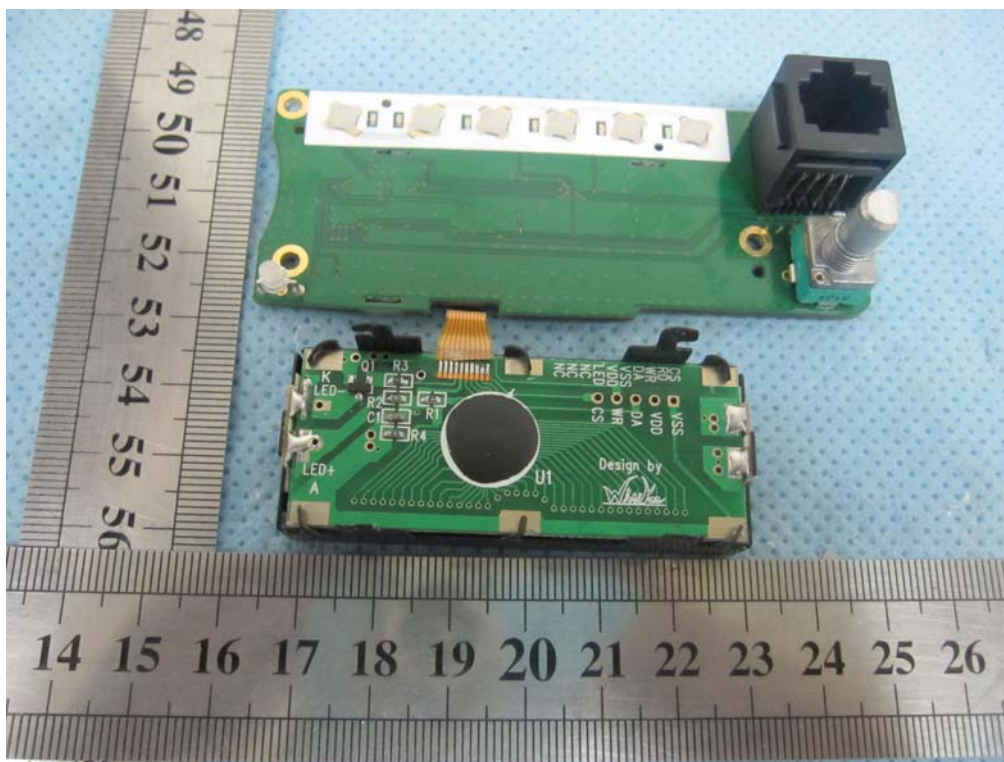
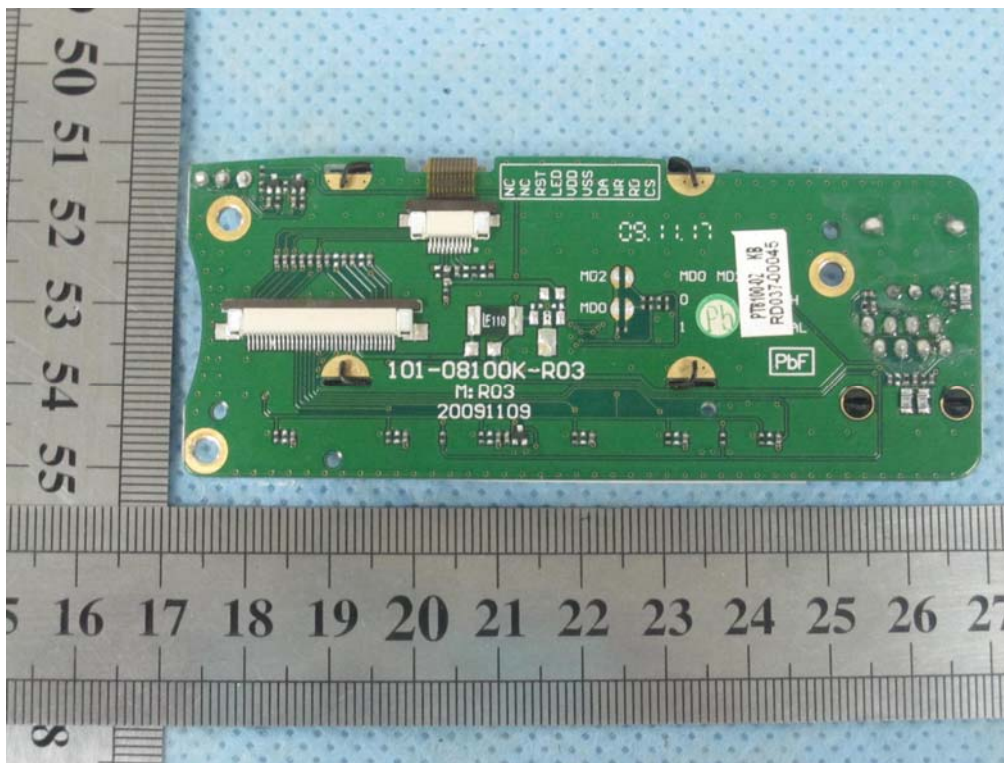

.....End of Report.....