

**ELECTROMAGNETIC EMISSIONS COMPLIANCE REPORT  
INTENTIONAL RADIATOR CERTIFICATION TO  
FCC PART 90 REQUIREMENTS**

*OF*

**TWO-WAY RADIO**

**MODEL No.: PT6200-02**

**BRAND NAME: N/A**

**FCC ID: Q5EPT620002**

**REPORT NO: TRE06030005**

**ISSUE DATE: May 21, 2006**

*Prepared for*

**KIRISUN ELECTRONICS(SHENZHEN) CO., LTD.  
6/F., BLDG. H-2, EAST INDUSTRIAL ZONE OF OVERSEAS CHINESE  
TOWN NANSHAN DIST. SHENZHEN P.R. CHINA**

*Prepared by*

**SHENZHEN HUATONGWEI INTERNATIONAL  
INSPECTION CO., LTD**

*d.b.a.*

**SHENZHEN HUATONGWEI INTERNATIONAL INSPECTION CO., LTD  
HUATONGWEI BUILDING, KEJI RD. 12 S., HIGH-TECH PARK,  
NANSHAN DISTRICT, SHENZHEN,  
GUANGDONG , P.R.CHINA**

**TEL: 86-755-26748099**

**FAX: 86-755-26748089**

## VERIFICATION OF COMPLIANCE

Applicant:	KIRISUN ELECTRONICS (SHENZHEN) CO.,LTD. 6/F.,Bldg.H-2,East Industrial Zone of Overseas Chinese Town,Nanshan Dist.,Shenzhen P.R.China
Product Description:	FM Handheld Transceiver
Brand Name:	N/A
Model Number:	PT6200-02
Serial Number:	N/A
File Number:	TRE06030005
Date of Test:	March 20,2006 ~ May 19,2006

### We hereby certify that:

The above equipment was tested by SHENZHEN HUATONGWEI INTERNATIONAL INSPECTION CO., LTD. The test data, data evaluation, test procedures, and equipment configurations shown in this report were made in accordance with the procedures given in ANSI C63.4 (2003) and the energy emitted by the sample EUT tested as described in this report is in compliance with radiated emission limits of FCC Rules Part 90.

The test results of this report relate only to the tested sample identified in this report.

*Approved By*



---

**Jimmy Li / Executive Manager**  
SHENZHEN HUA TONG WEI  
INTERNATIONAL INSPECTION CO., LTD

*Reviewed By*



---

**Tracy Qi / Test Engineer**  
SHENZHEN HUA TONG WEI  
INTERNATIONAL INSPECTION CO., LTD

## Table of Contents

<b>1. GENERAL INFORMATION</b>	<b>5</b>
1.1 PRODUCT DESCRIPTION	5
1.2 RELATED SUBMITTAL(S) / GRANT(S)	5
1.3 TEST METHODOLOGY	5
1.4 TEST FACILITY	5
1.5 SPECIAL ACCESSORIES	5
1.6 EQUIPMENT MODIFICATIONS	5
1.7 EQUIPMENT	5
1.8 LABORATORY ACCREDITATIONS AND LISTINGS	6
<b>2. SYSTEM TEST CONFIGURATION</b>	<b>7</b>
2.1 EUT CONFIGURATION	7
2.2 EUT EXERCISE	7
2.3 GENERAL TECHNICAL REQUIREMENTS AND SUMMARY OF TEST RESULTS	7
2.4 CONFIGURATION OF TESTED SYSTEM	7
<b>3. DESCRIPTION OF TEST MODES</b>	<b>8</b>
<b>4. CONDUCTED EMISSION TEST</b>	<b>9</b>
4.1 MEASUREMENT PROCEDURE	9
4.2 TEST SETUP BLOCK DIAGRAM	9
4.3 TEST EQUIPMENT USED:	10
4.4 CONDUCTED POWER LINE EMISSION LIMITS	10
4.5 TEST RESULTS	10
<b>5. OCCUPIED BANDWIDTH</b>	<b>11</b>
5.1 PROVISIONS APPLICABLE	11
5.2 MEASUREMENT PROCEDURE	11
5.3 TEST SETUP BLOCK DIAGRAM	11
5.4 MEASUREMENT EQUIPMENT USED:	12
5.5 TEST RESULTS:	12
<b>6. RADIATED SPURIOUS EMISSION</b>	<b>16</b>
6.1 PROVISIONS APPLICABLE	16
6.2 MEASUREMENT PROCEDURE	16
6.3 TEST SETUP BLOCK DIAGRAM	18
6.4 MEASUREMENT EQUIPMENT USED:	19
6.5 TEST RESULTS:	20
<b>7. SPURIOUS EMISSION ON ANTENNA PORT</b>	<b>22</b>
7.1 PROVISIONS APPLICABLE	22
7.2 MEASUREMENT PROCEDURE	22
7.3 TEST SETUP BLOCK DIAGRAM	22
7.4 TEST RESULTS:	22
<b>8. MODULATION CHARACTERISTICS</b>	<b>26</b>
8.1 PROVISIONS APPLICABLE	26
8.2 MEASUREMENT METHOD	26
8.3 MEASUREMENT EQUIPMENT USED:	27
8.4 TEST RESULTS:	27
<b>9. FREQUENCY STABILITY MEASUREMENT</b>	<b>34</b>
9.1 PROVISIONS APPLICABLE	34
9.2 MEASUREMENT PROCEDURE	34
9.3 TEST SETUP BLOCK DIAGRAM	34
9.4 MEASUREMENT EQUIPMENT USED:	34
9.5 TEST RESULTS:	35
<b>10. CONDUCTED OUTPUT POWER</b>	<b>37</b>
10.1 PROVISIONS APPLICABLE	37
10.2 TEST PROCEDURE	37
10.3 TEST SETUP BLOCK DIAGRAM	37
10.4 MEASUREMENT EQUIPMENT USED:	37
10.5 TEST RESULTS:	37

---

<b>11. TRANSMITTER FREQUENCY BEHAVIOR .....</b>	<b>39</b>
11.1 PROVISIONS APPLICABLE .....	39
11.2 TEST METHOD .....	39
11.3 TEST SETUP BLOCK DIAGRAM.....	39
11.4 MEASUREMENT EQUIPMENT USED: .....	39
11.5 TEST RESULTS:.....	39
<b>APPENDIX 1 .....</b>	<b>41</b>
<b>PHOTOGRPHS OF TEST SETUP .....</b>	<b>41</b>
<b>APPENDIX 2 .....</b>	<b>43</b>
<b>PHOTOGRPHS OF EUT .....</b>	<b>43</b>

## 1. GENERAL INFORMATION

### 1.1 PRODUCT DESCRIPTION

The Kirisun Electronics (Shenzhen) Co., Ltd.'s Model: PT6200 or the "EUT" as referred to in this report is an FM Handheld Transceiver, which measures approximately 56mmL x 120mmW x 35mmH.

\* The test data gathered are from typical production samples provided by the manufacturer.

A major technical descriptions of EUT is described as following:

B). Modulation: FM

C). Maximum Transmitter Power: 4W

D). Output power Modification: Fixed can't be changed

E). Antenna Designation: Detachable

F). Power Supply: DC 7.2 V by battery

G). Operating Frequency Range

Frequency Range: 430M ~ 470MHz

### 1.2 RELATED SUBMITTAL(S) / GRANT(S)

This submittal(s) (test report) is intended for FCC ID: Q5EPT620001 filing to comply with the FCC Part 90 requirements

### 1.3 TEST METHODOLOGY

The radiated emission testing was performed according to the procedures of ANSI C63.4 and FCC CFR 47 2.1046, 2.1047, 2.1049, 2.1051, 2.1053, and 2.1055.

### 1.4 TEST FACILITY

The fully anechoic chamber test site and conducted measurement facility used to collect the radiated data is located on the address of SHENZHEN HUATONGWEI INTERNATIONAL INSPECTION CO., LTD Huatongwei Building, Keji Rd. 12 S., High-tech Park, Nanshan District, Shenzhen, Guangdong, P.R.China

The fully anechoic chamber Test Sites and the Line Conducted labs are constructed and calibrated to meet the FCC requirements in documents ANSI C63.4: 2003 and CISPR 22/EN 55022 requirements.

### 1.5 SPECIAL ACCESSORIES

Not available for this EUT intended for grant.

### 1.6 EQUIPMENT MODIFICATIONS

Not available for this EUT intended for grant.

### 1.7 EQUIPMENT

Radiated emissions are measured with one or more of the following types of linearly polarized antennas: tuned dipole, biconical, log periodic, bi-log, and/or ridged waveguide, horn. Spectrum analyzers with preselectors and quasi-peak detectors are used to perform radiated measurements.

Conducted emissions are measured with Line Impedance Stabilization Networks and EMI Test Receivers.

Calibrated wideband preamplifiers, coaxial cables, and coaxial attenuators are also used for making

measurements.

All receiving equipment conforms to CISPR Publication 16-1, "Radio Interference Measuring Apparatus and Measurement Methods."

## **1.8 LABORATORY ACCREDITATIONS AND LISTINGS**

### **NEMKO-Aut. No.: ELA125**

Shenzhen Huatongwei International Inspection Co., Ltd has been assessed the quality assurance system, the testing facilities, qualifications and testing practices of the relevant parts of the organization. The quality assurance system of the Laboratory has been validated against ISO/IEC 17025 or equivalent. The laboratory also fulfils the conditions described in Nemko Document NLA-10.

### **CNAL-Lab Code: L1225**

Shenzhen Huatongwei International Inspection Co., Ltd has been assessed and proved to be in compliance with CNAL/AC01: 2003 Accreditation Criteria for Testing and Calibration Laboratories (identical to ISO/IEC 17025: 1999 General Requirements) for the Competence of Testing and Calibration Laboratories.

### **FCC-Registration No.: 662850**

Shenzhen Huatongwei International Inspection Co., Ltd, EMC Laboratory has been registered and fully described in a report filed with the FCC (Federal Communications Commission). The acceptance letter from the FCC is maintained in our files. Registration 662850, November 17, 2003.

### **VCCI**

The 3m Semi-anechoic chamber (12.2m×7.95m×6.7m) and Shielded Room (8m×4m×3m) of Shenzhen Huatongwei International Inspection Co., Ltd has been registered in accordance with the Regulations for Voluntary Control Measures with Registration No.: R-1920 and

C-2067 respectively. Date of Registration: July 28, 2004. Valid time is until November 16, 2006. The Shielded Room (8m×4m×3m) of Shenzhen Huatongwei International Inspection Co., Ltd has been registered in accordance with the Regulations for Voluntary Control Measures with Registration No.: T-175 respectively. Date of Registration: July 28, 2004. Valid time is until July 27, 2007.

## 2. SYSTEM TEST CONFIGURATION

### 2.1 EUT CONFIGURATION

The EUT configuration for testing is installed on RF field strength measurement to meet the Commission’s requirement and operating in a manner which intends to maximize its emission characteristics in a continuous normal application.

### 2.2 EUT EXERCISE

The Transmitter was operated in the normal operating mode. the TX frequency was fixed which was for the purpose of the measurements.

### 2.3 GENERAL TECHNICAL REQUIREMENTS AND SUMMARY OF TEST RESULTS

The EUT has been tested according to the following specifications:

Standard	Test Type	Result	Notes
FCC Part 15, Paragraph 15.107	AC Line Conducted Emission	N/A	Owing to the DC operation of EUT, this test item is not
FCC 2.1046 & 90.205(h)	RF Output Power	PASS	Complies
FCC 2.1047 & 90.207 & 90.210(b)	Modulation Characteristics	PASS	Complies
FCC 2.1049 & 90.209(b)(5) & 90.210(b)	Occupied Bandwidth	PASS	Complies
FCC 2.1053 & 90.210(b)	Radiated Spurious Emission	PASS	Complies.
FCC 2.1051 & 90.210(b)	Spurious Emission on Antenna Port	PASS	Complies.
FCC 2.1055 & 90.213	Frequency Stability Vs. Temperature Vs. Voltage	PASS	Complies.
FCC Section 90.214	Transient Frequency Behavior	PASS	Complies.

### 2.4 CONFIGUARATION OF TESTED SYSTEM

Fig. 2-1 Configuration of Tested System

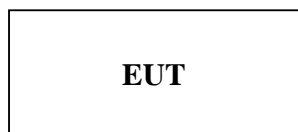

### **3. DESCRIPTION OF TEST MODES**

The EUT (Two-way Radio) has been tested under normal operating condition. Three channels are chosen for testing.



## 4. CONDUCTED EMISSION TEST

### 4.1 MEASUREMENT PROCEDURE

The EUT was tested according to ANSI C63.4 - 2003. The frequency spectrum from 0.15 MHz to 30 MHz was investigated. The LISN used was 50 ohm / 50 u Henry as specified by section 5.1 of ANSI C63.4 - 2003. cables and peripherals were moved to find the maximum emission levels for each frequency.

**Note: The EUT will not be operated during charging the battery with the power adapter.**

### 4.2 TEST SETUP BLOCK DIAGRAM

(block diagram of configuration)

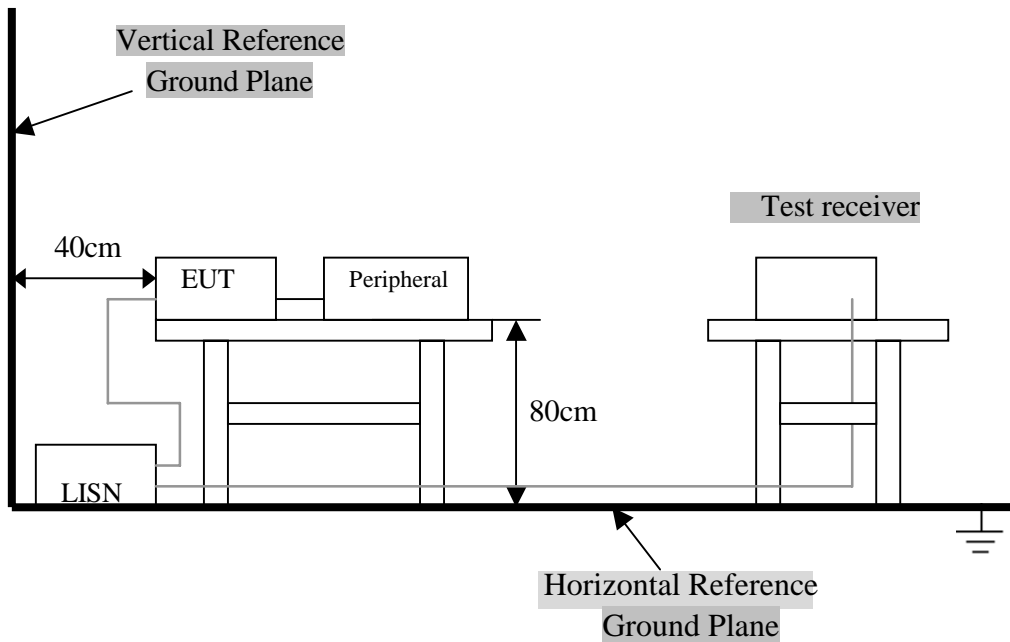

**For the actual test configuration, Please refer to the related items – Photos of Testing.**

**4.3 TEST EQUIPMENT USED:**

<b>Conducted Emission Test Site # 3</b>					
<b>EQUIPMENT TYPE</b>	<b>MFR</b>	<b>MODEL NUMBER</b>	<b>SERIAL NUMBER</b>	<b>LAST CAL.</b>	<b>CAL DUE.</b>
EMI TEST RECEIVER	ROHDE & SCHWARZ	ESCS30	100038	2005/11	2006/11
ARTIFICIAL MAINS	ROHDE & SCHWARZ	ESH2-Z5	100028	2005/11	2006/11
PULSE LIMITER	ROHDE & SCHWARZ	ESHSZ2	100044	2005/11	2006/11
EMI TEST SOFTWARE	ROHDE & SCHWARZ	ES-K1 V1.71	N/A	N/A	2006/11

**4.4 CONDUCTED POWER LINE EMISSION LIMITS**

<b>FCC Part 15 Paragraph 15.107 (dBuV)</b>		
<b>Frequency Range (MHz)</b>	<b>Class A QP/AV</b>	<b>Class B QP/AV</b>
0.15 – 0.5	79/66	66-56/56-46
0.5 – 5.0	73/60	56/46
5.0 - 30	73/60	60/50

**NOTE** : In the above table, the tighter limit applies at the band edges.

**4.5 TEST RESULTS**

Owing to the DC operation of EUT, this test item is not performed.

## 5. OCCUPIED BANDWIDTH

### 5.1 PROVISIONS APPLICABLE

According to FCC Part 90 Section 90.209: The authorized bandwidth shall be 12.5 KHz.

For any frequency removed from the center of the authorized bandwidth  $f_0$  to 5.625kHz removed from  $f_0$ , 0dB.

On any frequency removed from the center of the authorized bandwidth by a displacement frequency ( $f_d$  in kHz) of more than 5.626kHz but no more than 12.5kHz, at least  $7.27 (f_d - 2.88\text{kHz})$  dB.

On any frequency removed from the center of the authorized bandwidth by a displacement frequency ( $f_d$  in kHz) of more than 12.5kHz at least:

$$50 + 10\log P = 50 + 10\log(4.295) = 56.6\text{dB}$$

### 5.2 MEASUREMENT PROCEDURE

- 1). The EUT was placed on a turntable which is 0.8m above ground plane.
- 2). Set EUT as normal operation
- 3). Set SPA Center Frequency = fundamental frequency, RBW=300Hz, VBW= 3KHz, span =100KHz.

### 5.3 TEST SETUP BLOCK DIAGRAM

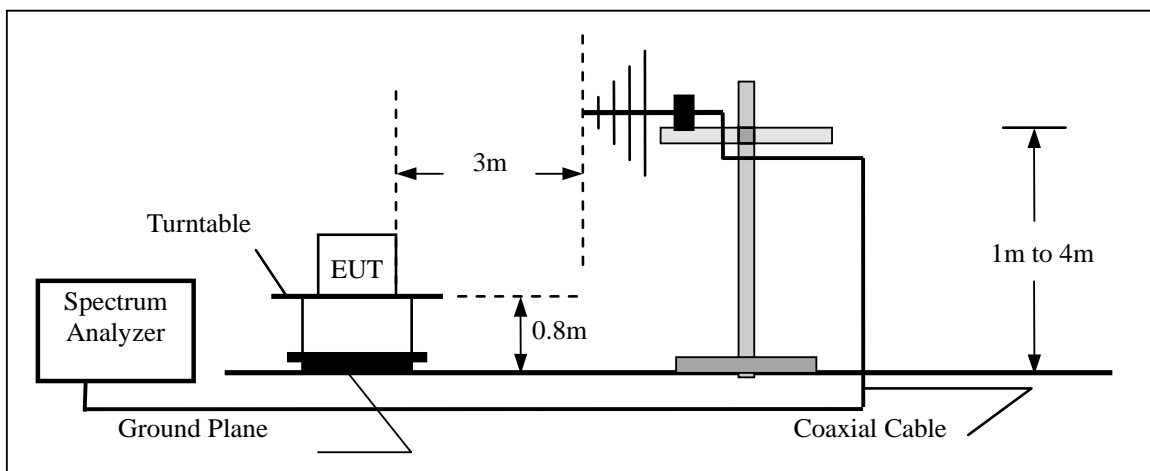

**5.4 MEASUREMENT EQUIPMENT USED:**

<b>3/5 Anechoic Chamber Radiation Test Site # 4</b>					
<b>EQUIPMENT TYPE</b>	<b>MFR</b>	<b>MODEL NUMBER</b>	<b>SERIAL NUMBER</b>	<b>LAST CAL.</b>	<b>CAL DUE.</b>
ULTRA-BROADBAND ANTENNA	ROHDE & SCHWARZ	HL562	100015	2005/11	2006/11
EMI TEST RECEIVER	ROHDE & SCHWARZ	ESI 26	100009	2005/11	2006/11
RF TEST PANEL	ROHDE & SCHWARZ	TS / RSP	335015/ 0017	N/A	N/A
TURNTABLE	ETS	2088	2149	N/A	N/A
ANTENNA MAST	ETS	2075	2346	N/A	N/A
EMI TEST SOFTWARE	ROHDE & SCHWARZ	ES-K1 V1.71	NA	2005/11	2006/11

**5.5 TEST RESULTS:**

Referred as the attached plot hereinafter

Note: The blue curve represents unmodulated signal.

The black curve represents modulated signal.

### Occupied Bandwidth of CH 01

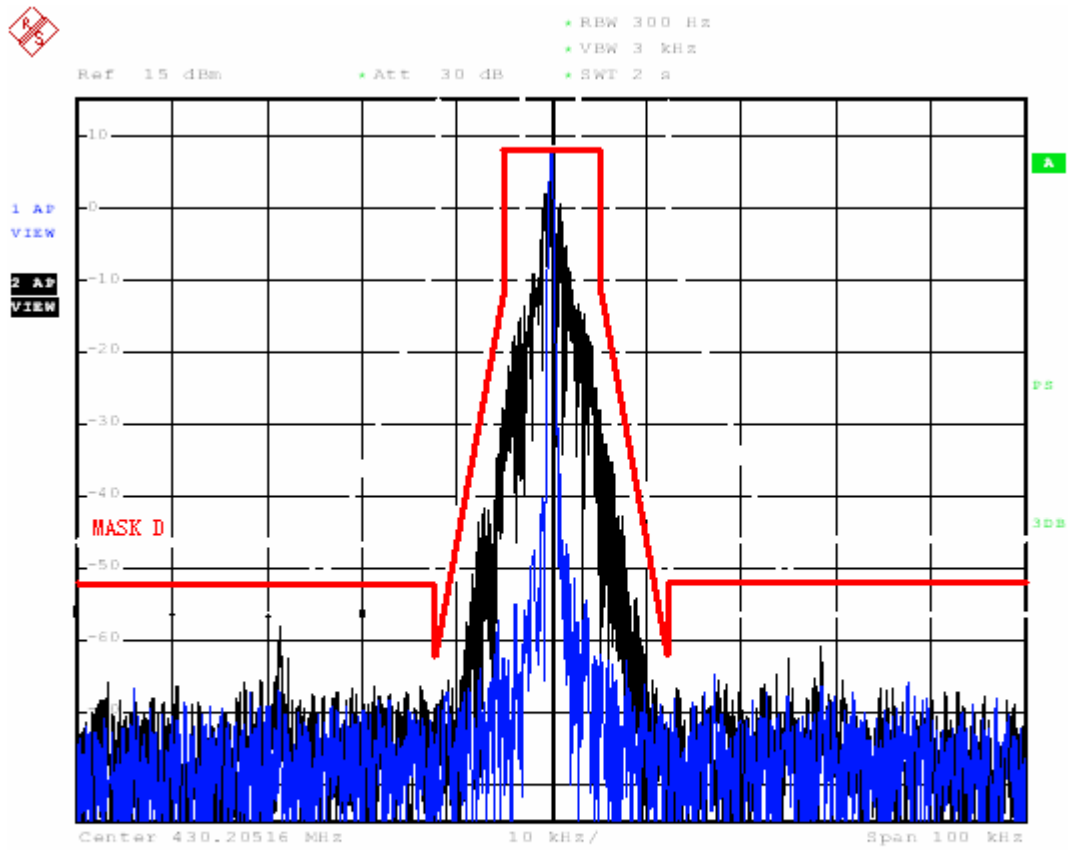

Date: 2.JUN.2006 14:16:52

12.5 kHz Channel Spacing, 430MHz, 2500 Hz Audio Modulation Only

### Occupied Bandwidth of CH02

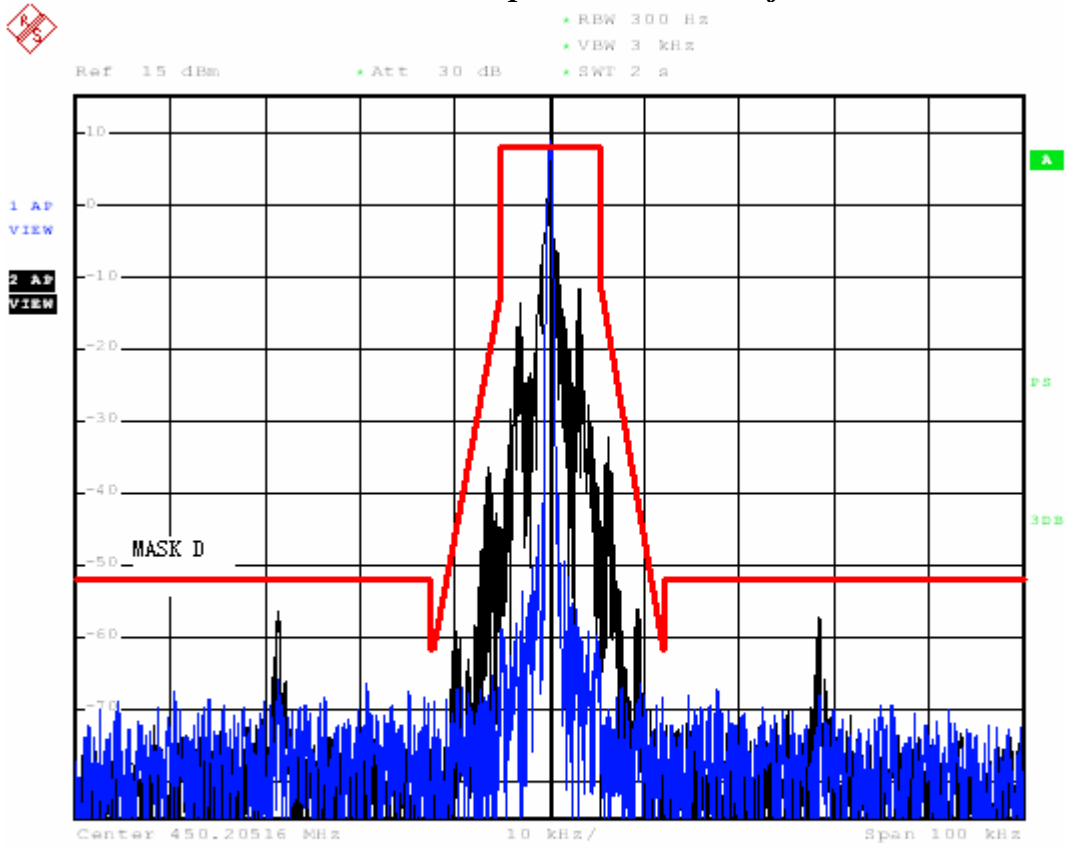

Date: 2.JUN.2006 14:21:01

12.5 kHz Channel Spacing, 450 MHz, 2500 Hz Audio Modulation Only

### Occupied Bandwidth of CH 03

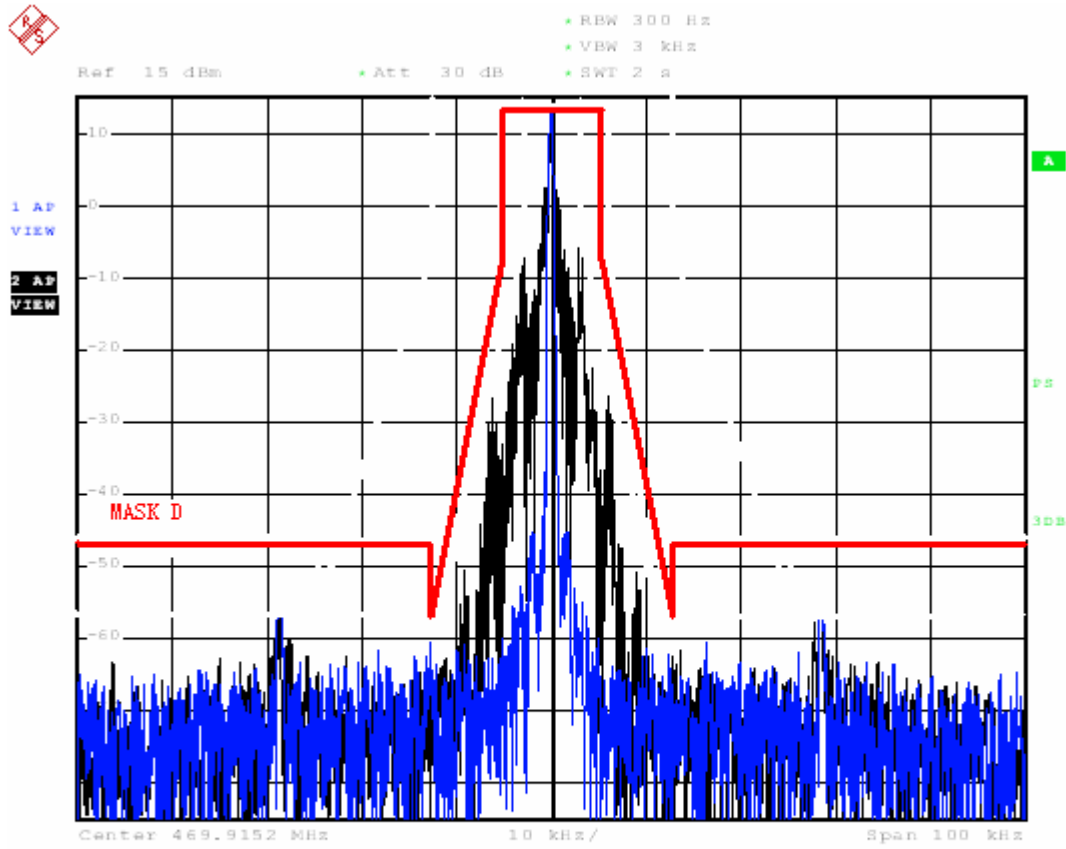

Date: 2.JUN.2006 14:23:37

12.5 kHz Channel Spacing, 470 MHz, 2500 Hz Audio Modulation Only

## 6. RADIATED SPURIOUS EMISSION

### 6.1 PROVISIONS APPLICABLE

According to Section 90.210, the power of each unwanted emission shall be less than Transmitted Power as specified below for transmitters designed to operate with 12.5 KHz channel bandwidth:

- 1). On any frequency removed from the center of the authorized bandwidth  $f_0$  to 5.625 KHz removed from  $f_0$ : Zero dB
- 2). On any frequency removed from the center of the authorized bandwidth by a displacement frequency ( $f_d$  in KHz)  $f_0$  of more than 5.625 KHz but no more than 12.5 KHz: At least 7.27dB
- 3). On any frequency removed from the center of the authorized bandwidth by a displacement frequency ( $f_d$  in KHz)  $f_0$  of more than 12.5 KHz: At least  $50+10 \log(P)$  dB or 70 dB, which ever is lesser attenuation.

### 6.2 MEASUREMENT PROCEDURE

- 1). On a test site, the EUT shall be placed on a turntable, and in the position closest to the normal use as declared by the user.
- 2). The test antenna shall be oriented initially for vertical polarization located 3m from the EUT to correspond to the transmitter.
- 3). The output of the antenna shall be connected to the measuring receiver and either a peak or quasi-peak detector was used for the measurement as indicated on the report. The detector selection is based on how close the emission level was approaching the limit.
- 4). The transmitter shall be switched on; if possible, without the modulation and the measurement receiver shall be tuned to the frequency of the transmitter under test.
- 5). The test antenna shall be raised and lowered through the specified range of height until the measuring receiver detects a maximum signal level.
- 6). The transmitter shall than be rotated through  $360^\circ$  in the horizontal plane, until the maximum signal level is detected by the measuring receiver.
- 7). The test antenna shall be raised and lowered again through the specified range of height until the measuring receiver detects a maximum signal level.
- 8). The maximum signal level detected by the measuring receiver shall be noted.
- 9). The measurement shall be repeated with the test antenna set to horizontal polarization.
- 10). Replace the antenna with a proper Antenna (substitution antenna).
- 11). The substitution antenna shall be oriented for vertical polarization and, if necessary, the length of the substitution antenna shall be adjusted to correspond to the frequency of transmitting.
- 12). The substitution antenna shall be connected to a calibrated signal generator.
- 13). If necessary, the input attenuator setting of the measuring receiver shall be adjusted in order to increase the sensitivity of the measuring receiver.
- 14). The test antenna shall be raised and lowered through the specified range of the height to ensure that the maximum signal is received.



15). The input signal to substitution antenna shall be adjusted to the level that produces a level detected by the measuring receiver, that is equal to the level noted while the transmitter radiated power was measured, corrected for the change of input attenuation setting of the measuring receiver.

16). The input level to the substitution antenna shall be recorded as power level in dBm, corrected for any change of input attenuator setting of the measuring receiver.

17). The measurement shall be repeated with the test antenna and the substitution antenna oriented for horizontal polarization

### 6.3 TEST SETUP BLOCK DIAGRAM

(block diagram of configuration)

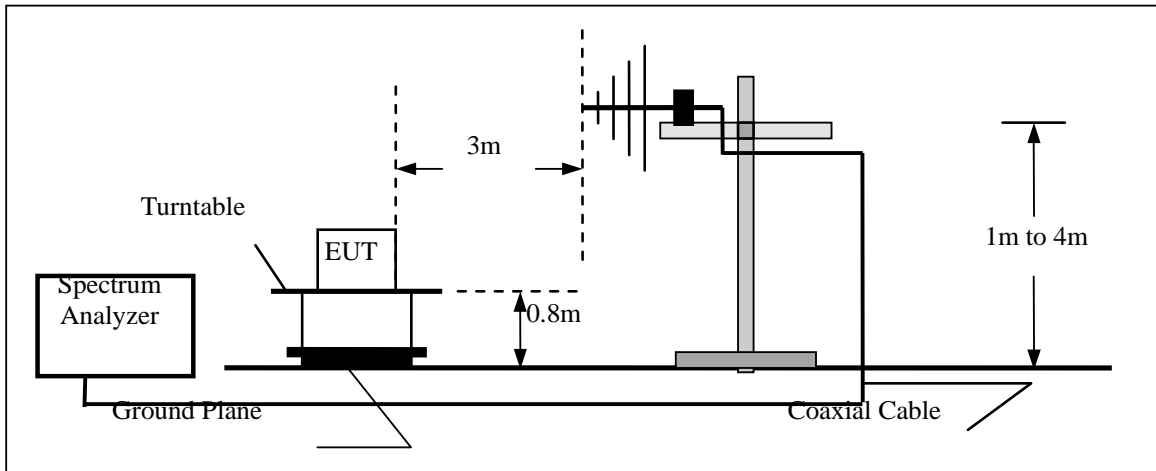

#### Radiation below 1GHz

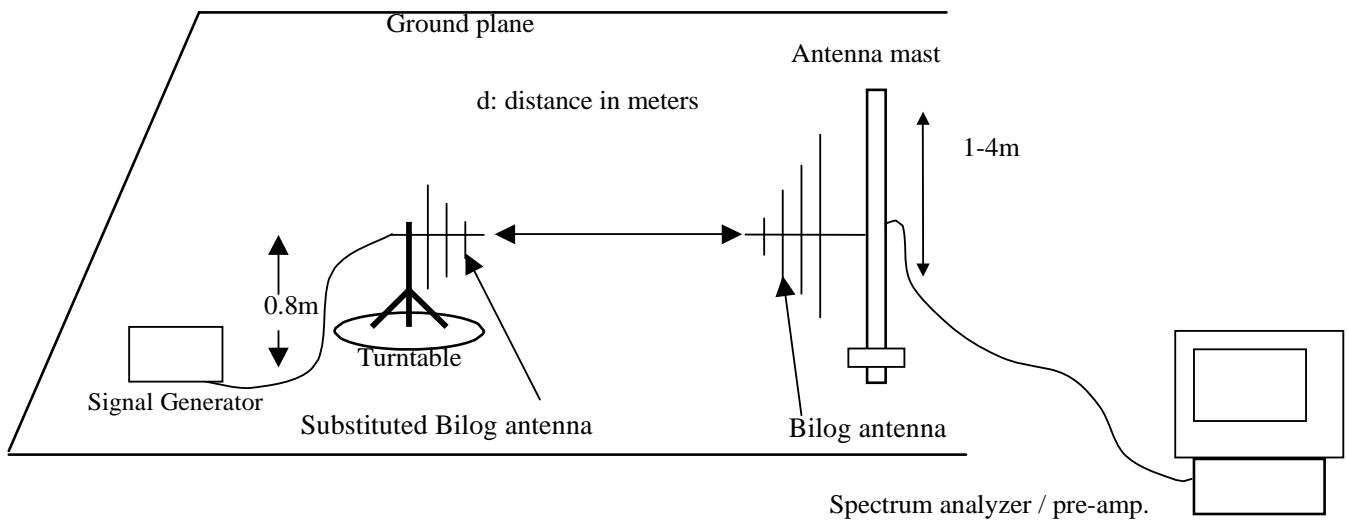

Radiation above 1GHz

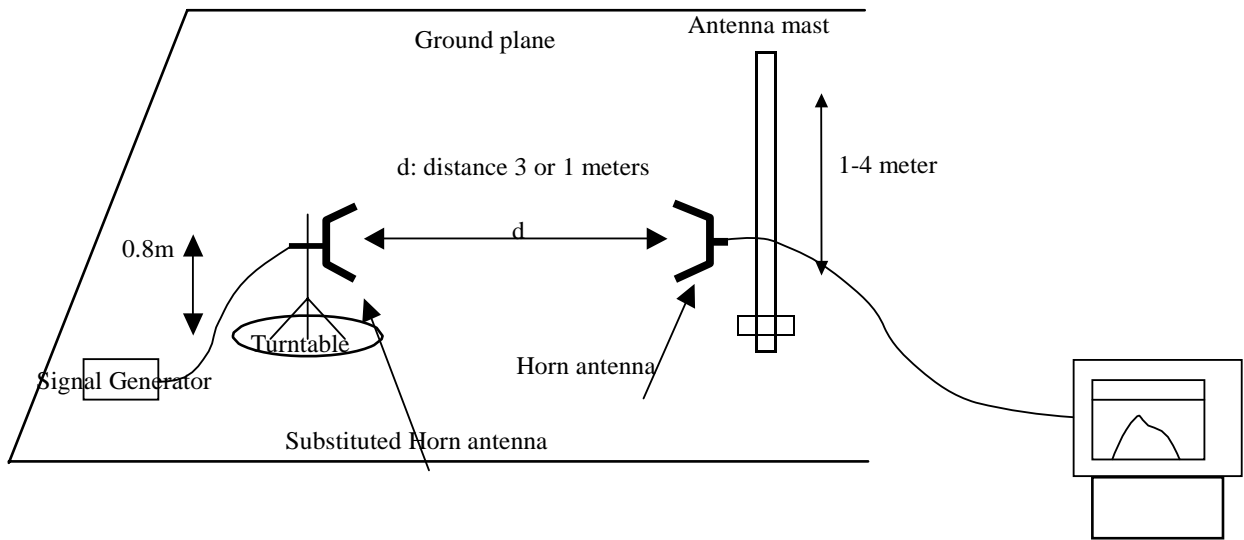

6.4 MEASUREMENT EQUIPMENT USED:

Radiated Emission Test Site # 4				
Name of Equipment	Manufacturer	Model	Serial Number	Calibration Due
ULTRA-BROADBAND ANTENNA	ROHDE & SCHWARZ	HL562	100015	11/14/2006
EMI TEST RECEIVER	ROHDE & SCHWARZ	ESI 26	100009	11/12/2006
RF TEST PANEL	ROHDE & SCHWARZ	TS / RSP	335015/ 0017	N/A
TURNTABLE	ETS	2088	2149	N/A
ANTENNA MAST	ETS	2075	2346	N/A
EMI TEST SOFTWARE	ROHDE & SCHWARZ	ES-K1 V1.71	N/A	11/12/2006

**6.5 TEST RESULTS:**

FCC Part 22.359, 74.462, 80.211 and 90.210 (25 kHz bandwidth only):

On any frequency removed from the center of the assigned channel by more than 250 percent at least:

Low:  $43 + 10 \log (P_{\text{watts}}) = 43 + 10 \log (3.98) = 49.0 \text{ dB}$

Middle:  $43 + 10 \log (P_{\text{watts}}) = 43 + 10 \log (4.59) = 49.6 \text{ dB}$

High:  $43 + 10 \log (P_{\text{watts}}) = 43 + 10 \log (4.78) = 49.8 \text{ dB}$

FCC Part 90.210 (12.5 kHz Bandwidth only):

On any frequency removed from the center of the authorized bandwidth by a displacement frequency ( $f_d$  in kHz) of more than 12.5 kHz at least:

Low:  $50 + 10 \log (P_{\text{watts}}) = 50 + 10 \log (3.98) = 56.0 \text{ dB}$

Middle:  $50 + 10 \log (P_{\text{watts}}) = 50 + 10 \log (4.59) = 56.6 \text{ dB}$

High:  $50 + 10 \log (P_{\text{watts}}) = 50 + 10 \log (4.78) = 56.8 \text{ dB}$

Note: In general, the worse case attenuation requirement shown above was applied.

Product : FM Handheld Transceiver  
 Test Item : Radiated Spurious Emission  
 Test Voltage: DC 7.2V (External Power Supply)  
 Test Result: **PASS**

Test Mode : CH1-430MHz  
 Temperature : 25°C  
 Humidity : 56%RH

**Channel 01**

Frequency (MHz)	FCC Maximum Limit	HORIZ /VERT	Level in dBm	Margin
860.120	-20	V	-28.38	-8.38
860.120	-20	H	-32.51	-12.51
1290.180	-20	V	-50.17	-30.17
1290.180	-20	H	-52.54	-32.54
1720.240	-20	V	-57.82	-37.82
1720.240	-20	H	-58.67	-38.67
2150.300	-20	V	*	*
2150.300	-20	H	*	*
2580.360	-20	V	*	*
2580.360	-20	H	*	*
3010.420	-20	V	*	*
3010.420	-20	H	*	*

\* Indicates the spurious emission was less than -70dBm or could not be detected due to noise limitations or ambients.

Product : FM Handheld Transceiver  
 Test Item : Radiated Spurious Emission  
 Test Voltage: DC 7.2V (External Power Supply)  
 Test Result: **PASS**

Test Mode : CH2-450MHz  
 Temperature : 25°C  
 Humidity : 56%RH

**Channel 02**

Frequency (MHz)	FCC Maximum Limit	HORIZ /VERT	Level in dBm	Margin
898.600	-20	V	-30.25	-10.25
898.600	-20	H	-35.38	-15.38
1347.900	-20	V	-50.31	-30.31
1347.900	-20	H	-51.87	-31.87
1797.200	-20	V	-56.34	-36.34
1797.200	-20	H	-58.72	-38.72
2246.500	-20	V	*	*
2246.500	-20	H	*	*
2695.800	-20	V	*	*
2695.800	-20	H	*	*
3145.100	-20	V	*	*
3145.100	-20	H	*	*

\* Indicates the spurious emission was less than -70dBm or could not be detected due to noise limitations or ambients.

Product : FM Handheld Transceiver  
 Test Item : Radiated Spurious Emission  
 Test Voltage: DC 7.2V (External Power Supply)  
 Test Result: **PASS**

Test Mode : CH3-470MHz  
 Temperature : 25°C  
 Humidity : 56%RH

**Channel 03**

Frequency (MHz)	FCC Maximum Limit	HORIZ /VERT	Level in dBm	Margin
939.480	-20	V	-31.45	-11.45
939.480	-20	H	-36.31	-16.31
1409.220	-20	V	-50.43	-30.43
1409.220	-20	H	-54.37	-34.37
1878.960	-20	V	-57.78	-37.78
1878.960	-20	H	-58.96	-38.96
2348.700	-20	V	*	*
2348.700	-20	H	*	*
2818.440	-20	V	*	*
2818.440	-20	H	*	*
3288.180	-20	V	*	*
3288.180	-20	H	*	*

\* Indicates the spurious emission was less than -70dBm or could not be detected due to noise limitations or ambients.

## 7. SPURIOUS EMISSION ON ANTENNA PORT

### 7.1 PROVISIONS APPLICABLE

The same as Section 6.1.

### 7.2 MEASUREMENT PROCEDURE

The RF output of the EUT was connected to a spectrum analyzer through appropriate attenuation. The resolution bandwidth of the spectrum analyzer was set to 100 kHz. Sufficient scans were taken to show any out of band emission up to 10th. Harmonic for the lower, the middle and the highest frequency range. RBW 100kHz, VBW 100kHz, SPAN 1.9GHz, attenuation was set totally to 72.88dB, therefore in result no spurious emission to see anymore.

The audio input was set to 0 to get the unmodulated carrier, the resulting picture is print out for channel 1, 2 and 3.

### 7.3 TEST SETUP BLOCK DIAGRAM

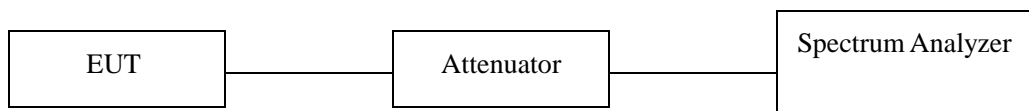

### 7.4 TEST RESULTS:

FCC Part 22.359, 74.462, 80.211 and 90.210 (25 kHz bandwidth only):

On any frequency removed from the center of the assigned channel by more than 250 percent at least:

Low:  $43 + 10 \log (\text{Pwatts}) = 43 + 10 \log (3.98) = 49.0 \text{ dB}$

Middle:  $43 + 10 \log (\text{Pwatts}) = 43 + 10 \log (4.59) = 49.6 \text{ dB}$

High:  $43 + 10 \log (\text{Pwatts}) = 43 + 10 \log (4.78) = 49.8 \text{ dB}$

FCC Part 90.210 (12.5 kHz Bandwidth only):

On any frequency removed from the center of the authorized bandwidth by a displacement frequency ( $f_d$  in kHz) of more than 12.5 kHz at least:

Low:  $50 + 10 \log (\text{Pwatts}) = 50 + 10 \log (3.98) = 56.0 \text{ dB}$

Middle:  $50 + 10 \log (\text{Pwatts}) = 50 + 10 \log (4.59) = 56.6 \text{ dB}$

High:  $50 + 10 \log (\text{Pwatts}) = 50 + 10 \log (4.78) = 56.8 \text{ dB}$

Note: In general, the worse case attenuation requirement shown above was applied.

Product : FM Handheld Transceiver Test Mode : CH1-430MHz  
 Test Item : Spurious Emission on Antenna Port Temperature : 25 °C  
 Test Voltage : DC 7.2V (External Power Supply) Humidity : 56%RH  
 Test Result : **PASS**

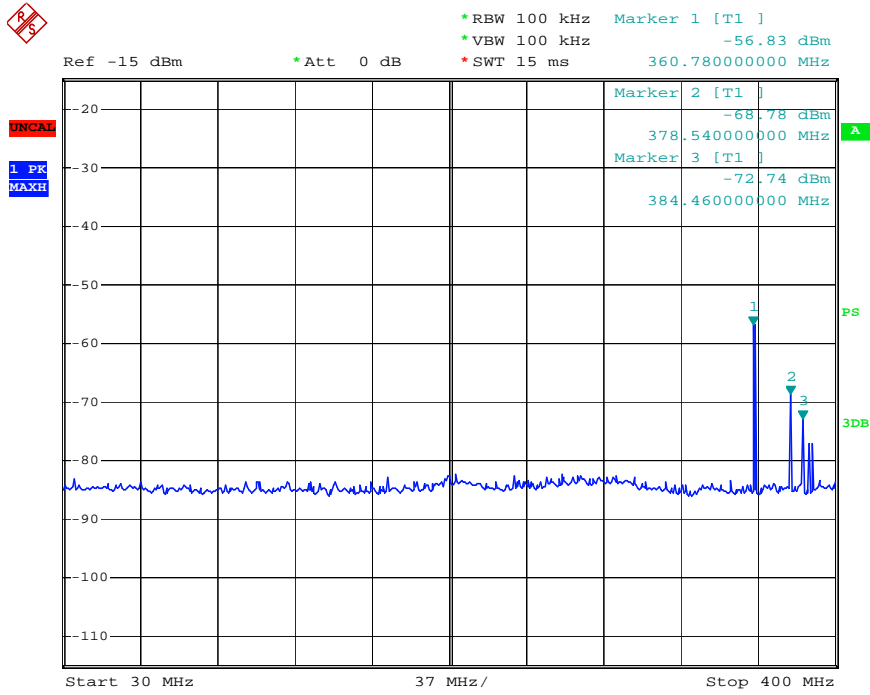

Date: 2.JUN.2006 14:40:57

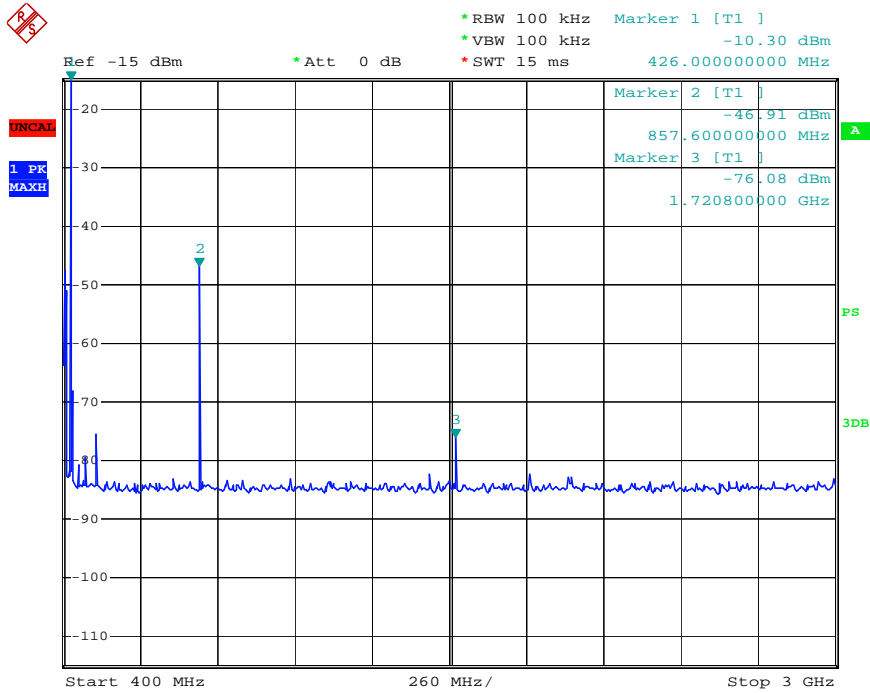

Date: 2.JUN.2006 14:38:59

Product : FM Handheld Transceiver Test Mode : CH2-450MHz  
 Test Item : Spurious Emission on Antenna Port Temperature : 25 °C  
 Test Voltage : DC 7.2V (External Power Supply) Humidity : 56%RH  
 Test Result : **PASS**

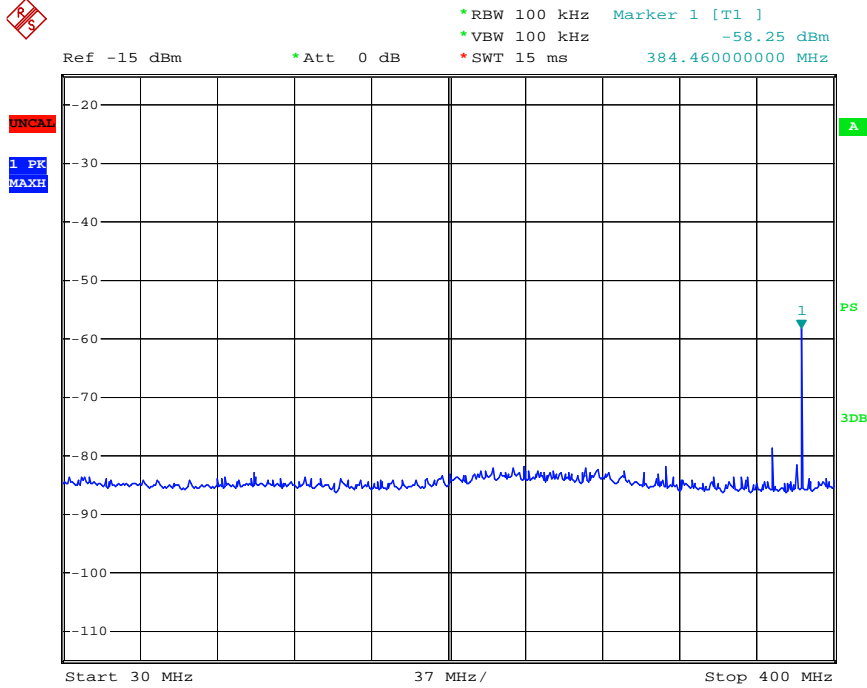

Date: 2.JUN.2006 14:42:21

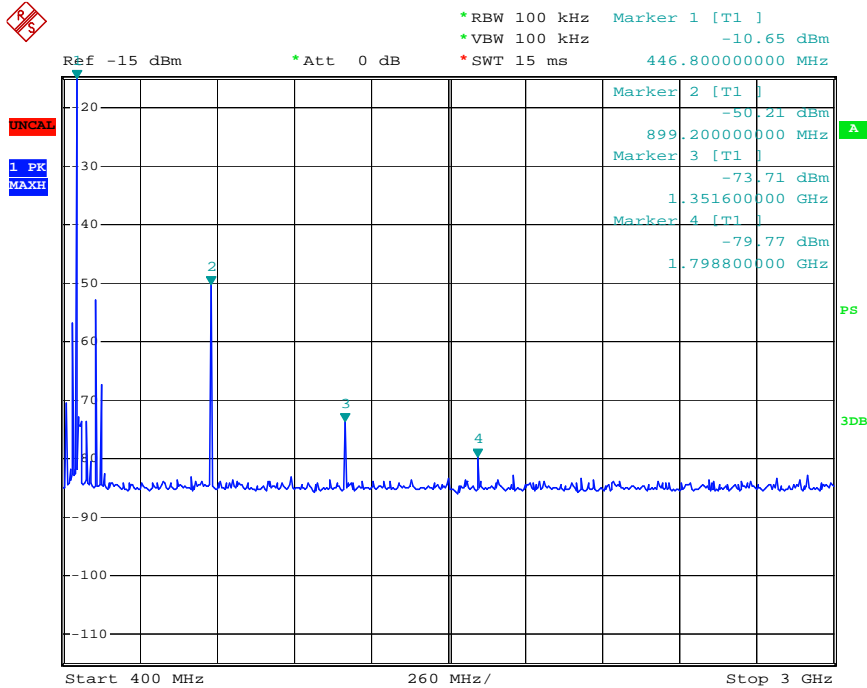

Date: 2.JUN.2006 14:44:00



Product : FM Handheld Transceiver Test Mode : CH3-470MHz  
 Test Item : Spurious Emission on Antenna Port Temperature : 25 °C  
 Test Voltage : DC 7.2V (External Power Supply) Humidity : 56%RH  
 Test Result : PASS

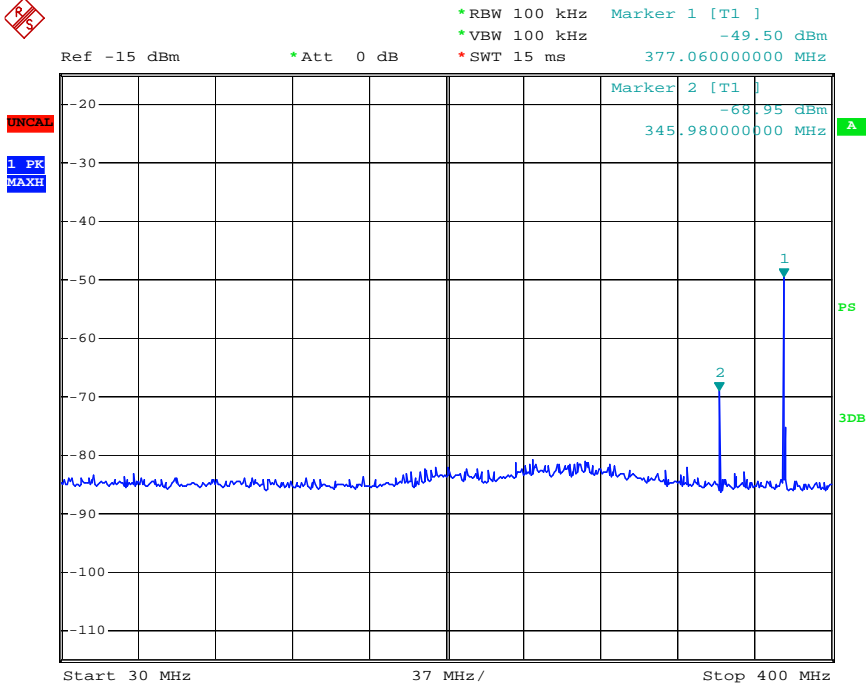

Date: 2.JUN.2006 14:47:58

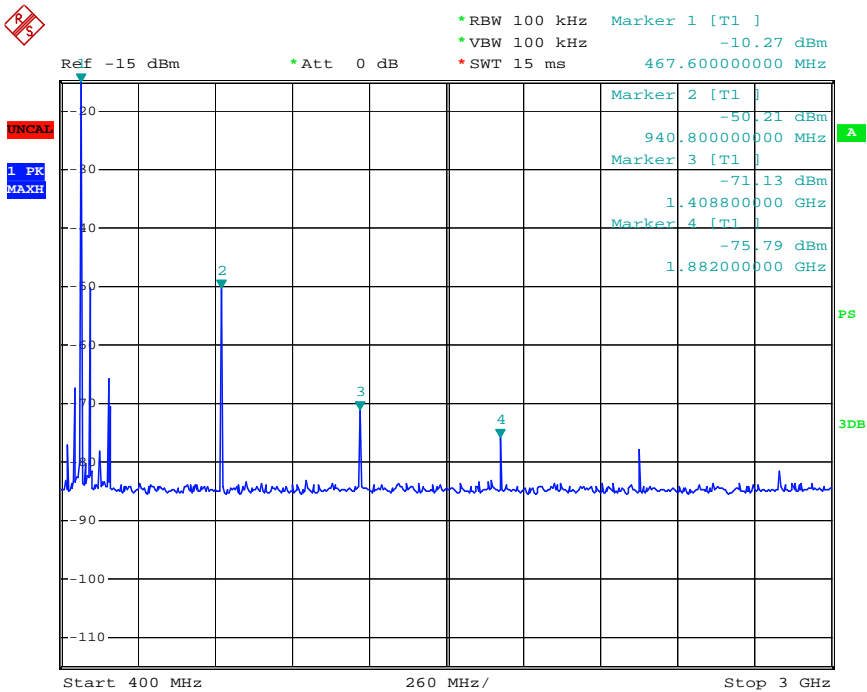

Date: 2.JUN.2006 14:46:28

## 8. MODULATION CHARACTERISTICS

### 8.1 PROVISIONS APPLICABLE

According to CFR47 section 2.1047(a), for Voice Modulation Communication Equipment, the frequency response of the audio modulation circuit over a range of 100 to 5000Hz shall be measured.

### 8.2 MEASUREMENT METHOD

#### 8.2.1 Modulation Limit

- 1). Configure the EUT as shown in figure 1, adjust the audio input for 60% of rated system deviation at 1KHz using this level as a reference (0dB) and vary the input level from -20 to +20dB. Record the frequency deviation obtained as a function of the input level.
- 2). Repeat step 1 with input frequency changing to 300,1004, and 2500Hz in sequence.

#### 8.2.2 Audio Frequency Response

- 1). Configure the EUT as shown in figure 1.
- 2). Adjust the audio input for 20% of rated system deviation at 1 KHz using this level as a reference (0dB).
- 3). Vary the Audio frequency from 100 Hz to 10 KHz and record the frequency deviation.
- 4) Audio Frequency Response =  $20\log_{10}(\text{Deviation of test frequency}/\text{Deviation of 1KHz reference})$ .

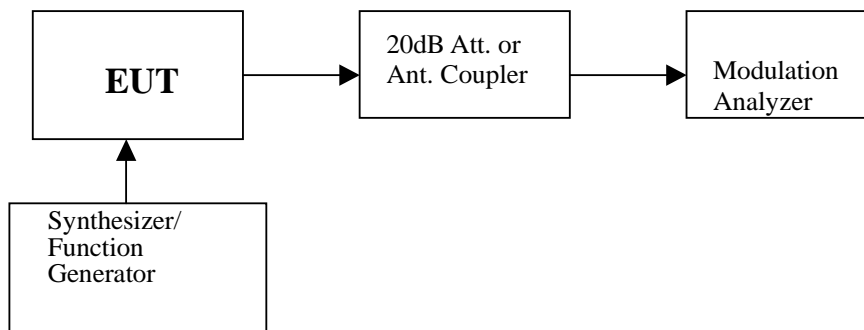

**8.3 MEASUREMENT EQUIPMENT USED:**

Name of Equipment	Manufacturer	Model	Serial Number	Calibration Due
Modulation Analyzer	HP	8901B	3104A03367	07/08/2006
Signal Generator	Rohde&Schwarz	SMT03	100059	02/01/2007

**8.4 TEST RESULTS:**

a). Modulation Limit:

**Channel 01**

Modulation Level (dB)	Peak Freq. Deviation At 300 Hz (KHz)	Peak Freq. Deviation At 1004 Hz	Peak Freq. Deviation At 1500 Hz	Peak Freq. Deviation At 2500 Hz
-20	0.990	1.163	1.192	1.130
-15	1.114	1.189	1.221	1.162
-10	1.203	1.225	1.246	1.227
-5	1.281	1.281	1.314	1.275
0	1.302	1.500	1.558	1.372
+5	1.418	1.691	1.726	1.555
+10	1.627	1.820	1.905	1.678
+15	1.823	1.934	2.032	1.826
+20	2.005	2.108	2.191	2.038

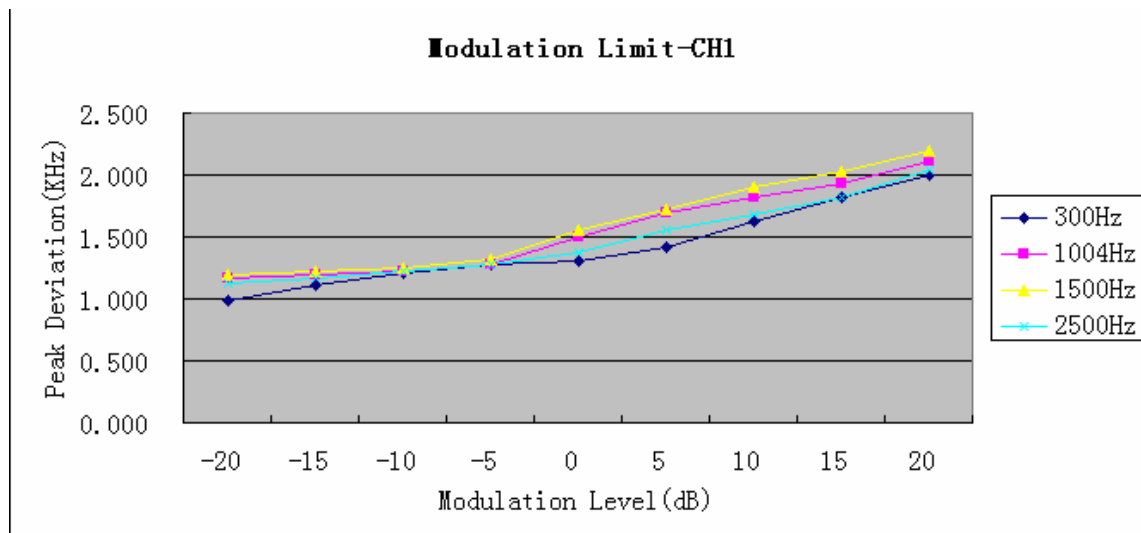

**Channel 02**

Modulation Level (dB)	Peak Freq. Deviation At 300 Hz (KHz)	Peak Freq. Deviation At 1004 Hz	Peak Freq. Deviation At 1500 Hz	Peak Freq. Deviation At 2500 Hz
-20	0.992	1.164	1.193	1.131
-15	1.115	1.190	1.223	1.161
-10	1.202	1.227	1.248	1.228
-5	1.280	1.282	1.311	1.274
0	1.303	1.500	1.557	1.374
+5	1.416	1.692	1.728	1.556
+10	1.625	1.822	1.902	1.679
+15	1.824	1.933	2.037	1.825
+20	2.001	2.109	2.194	2.035

**Modulation Limit-CH2**

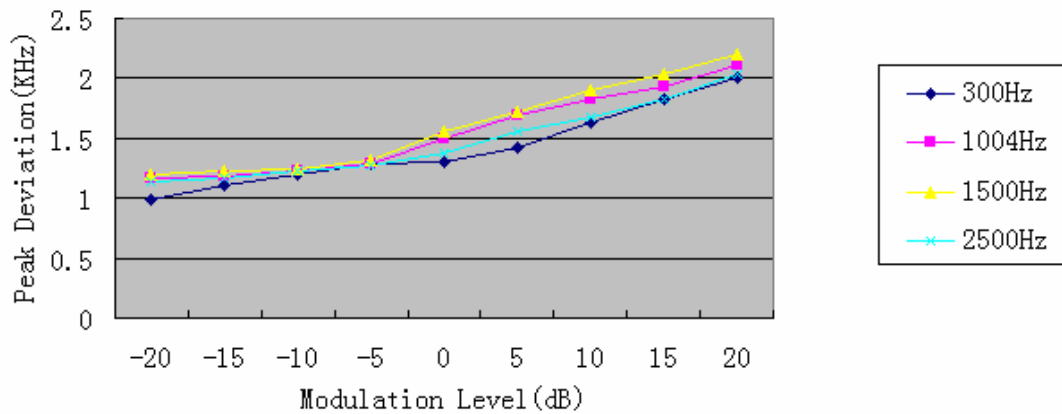

**Channel 03**

<b>Modulation Level (dB)</b>	<b>Peak Freq. Deviation At 300 Hz (KHz)</b>	<b>Peak Freq. Deviation At 1004 Hz</b>	<b>Peak Freq. Deviation At 1500 Hz</b>	<b>Peak Freq. Deviation At 2500 Hz</b>
-20	0.991	1.161	1.190	1.135
-15	1.116	1.194	1.225	1.163
-10	1.205	1.225	1.244	1.227
-5	1.283	1.286	1.315	1.276
0	1.300	1.500	1.553	1.372
+5	1.413	1.697	1.729	1.553
+10	1.628	1.820	1.904	1.676
+15	1.829	1.931	2.035	1.827
+20	2.006	2.112	2.197	2.038

**Modulation Limit-CH3**

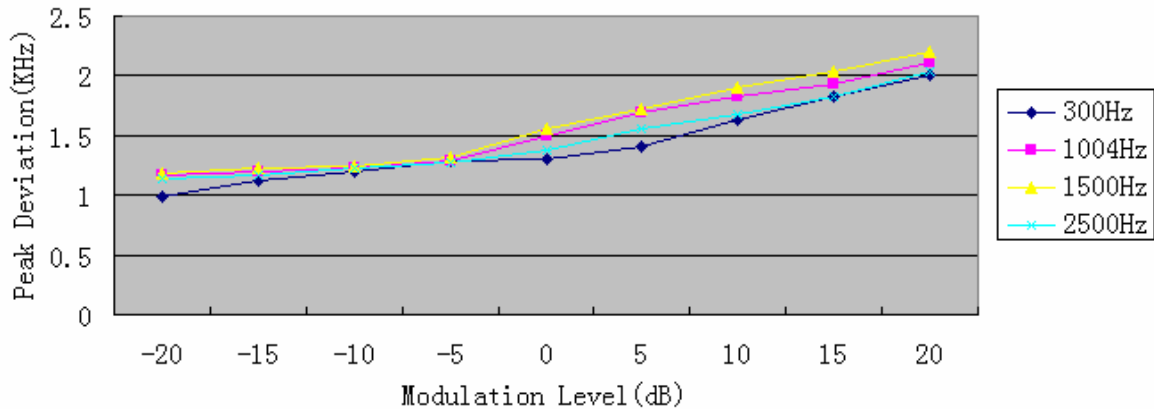

b). Audio Frequency Response:

Audio Frequency Response - CH 01

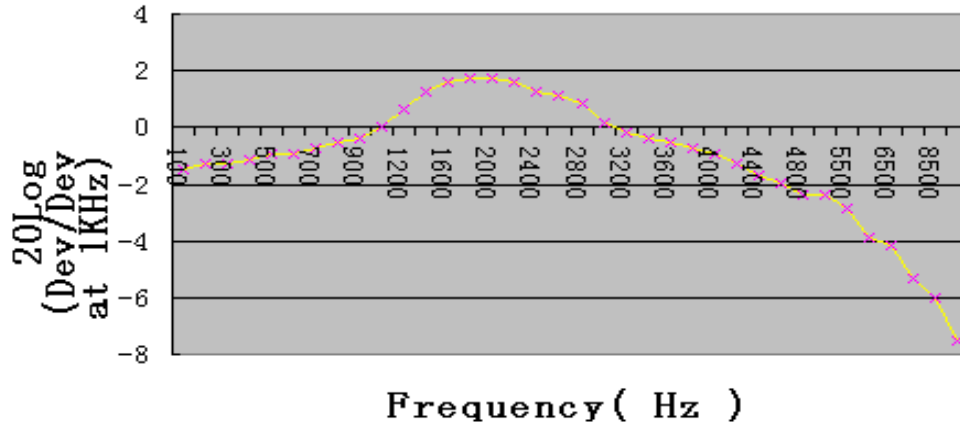

Audio Frequency Response - CH 02

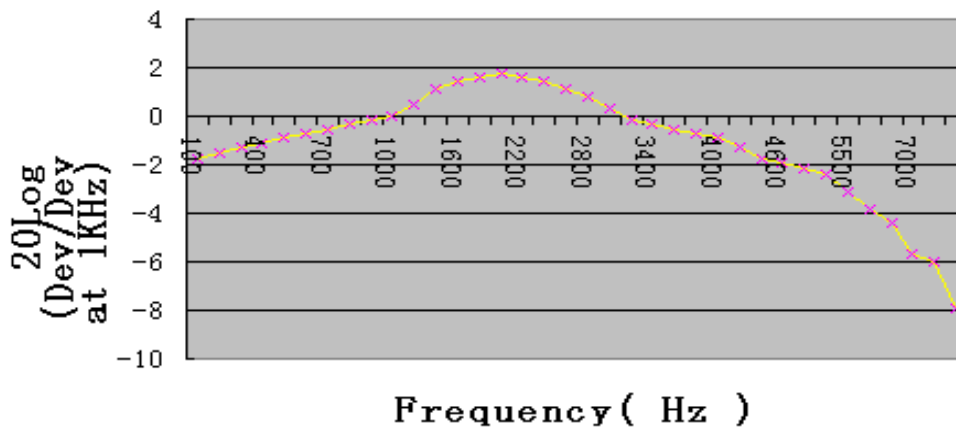

Audio Frequency Response - CH 03

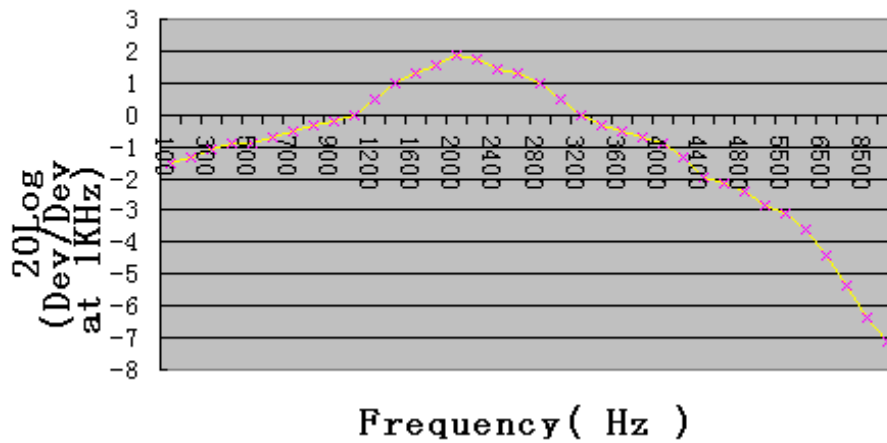

**Channel 01**

Frequency (Hz)	Deviation (KHz)
100	0.42
200	0.43
300	0.43
400	0.44
500	0.45
600	0.45
700	0.46
800	0.47
900	0.48
1000	0.50
1200	0.54
1400	0.58
1600	0.60
1800	0.61
2000	0.61
2200	0.60
2400	0.58
2600	0.57
2800	0.55
3000	0.51
3200	0.49
3400	0.48
3600	0.47
3800	0.46
4000	0.45
4200	0.43
4400	0.41
4600	0.40
4800	0.38
5000	0.38
5500	0.36
6000	0.32
6500	0.31
7000	0.27
8500	0.25
10000	0.21

**Channel 02**

Frequency (Hz)	Deviation (KHz)
100	0.41
200	0.42
300	0.43
400	0.44
500	0.45
600	0.46
700	0.47
800	0.48
900	0.49
1000	0.50
1200	0.53
1400	0.57
1600	0.59
1800	0.60
2000	0.61
2200	0.60
2400	0.59
2600	0.57
2800	0.55
3000	0.52
3200	0.49
3400	0.48
3600	0.47
3800	0.46
4000	0.45
4200	0.43
4400	0.41
4600	0.40
4800	0.39
5000	0.38
5500	0.35
6000	0.32
6500	0.30
7000	0.26
8500	0.25
10000	0.20



**Channel 03**

Frequency (Hz)	Deviation (KHz)
100	0.42
200	0.43
300	0.44
400	0.45
500	0.45
600	0.46
700	0.47
800	0.48
900	0.49
1000	0.50
1200	0.53
1400	0.56
1600	0.58
1800	0.60
2000	0.62
2200	0.61
2400	0.59
2600	0.58
2800	0.56
3000	0.53
3200	0.50
3400	0.48
3600	0.47
3800	0.46
4000	0.45
4200	0.43
4400	0.40
4600	0.39
4800	0.38
5000	0.36
5500	0.35
6000	0.33
6500	0.30
7000	0.27
8500	0.24
10000	0.22

## 9. FREQUENCY STABILITY MEASUREMENT

### 9.1 PROVISIONS APPLICABLE

According to §90.213, for operating band within 421-512MHz and output power > 2 watts, the frequency stability limit is 2.5 ppm.

### 9.2 MEASUREMENT PROCEDURE

The EUT was set in the climate chamber and connected to an external DC power supply. The RF output was directly connected to Spectrum Analyzer ESI 26. The coupling loss of the additional cables was recorded and taken in account for all the measurements. After temperature stabilization (approx. 20 min for each stage), the frequency for the lower, the middle and the highest frequency range was recorded. For Frequency stability Vs. Voltage the EUT was connected to an DC powersupply and the voltage was adjusted in the required ranges. The result was recorded.

### 9.3 TEST SETUP BLOCK DIAGRAM

(setup block diagram of configuration)

TEST SETUP:

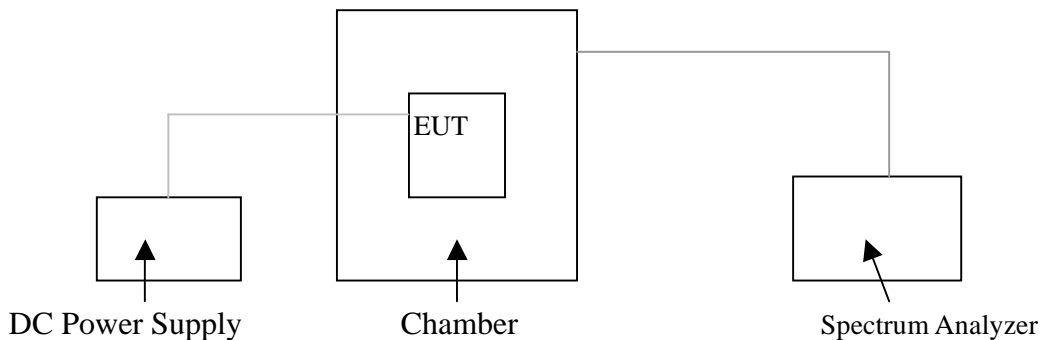

### 9.4 MEASUREMENT EQUIPMENT USED:

Name of Equipment	Manufacturer	Model	Serial Number	Calibration Due
Communication Test Set	HP	HP8920B	US35010135	06/01/2006
Signal Generator	Rohde&Schwarz	SMT03	100059	02/01/2007
Climate Chamber	ESPEC	EL-10KA	05107008	01/31/2007

**9.5 TEST RESULTS:**

a. Frequency stability versus input voltage (battery operation end point voltage is 6.0 V)

Channel	Reference Frequency (MHz)	Frequency Measured at end point voltage	Frequency Deviation (%)	Limit (%)
01	430.06000	430.05919	-0.00019	0.00025
02	449.29900	449.29851	-0.00010	0.00025
03	469.73900	469.73812	-0.00019	0.00025

b. Frequency stability versus ambient temperature

**Channel 01**

Reference Frequency: 430.06000 MHz		Limit: 0.00025%	
Environment Temperature (°C)	Power Supply (DC)	Frequency deviation measured with time Elapse (10 minutes)	
		(MHz)	%
50	7.2V	430.05927	-0.00017
40	7.2V	430.05938	-0.00014
30	7.2V	430.05939	-0.00014
20	7.2V	430.05958	-0.00010
10	7.2V	430.05941	-0.00014
0	7.2V	430.05936	-0.00015
-10	7.2V	430.05935	-0.00015
-20	7.2V	430.05932	-0.00016
-30	7.2V	430.05929	-0.00017

**Channel 02**

Reference Frequency: 449.29900 MHz			Limit: 0.00025%
Environment Temperature (°C)	Power Supply (DC)	Frequency deviation measured with time Elapse (10 minutes)	
		(MHz)	%
50	7.2V	449.29858	-0.00009
40	7.2V	449.29860	-0.00009
30	7.2V	449.29863	-0.00008
20	7.2V	449.29873	-0.00006
10	7.2V	449.29869	-0.00007
0	7.2V	449.29867	-0.00007
-10	7.2V	449.29861	-0.00009
-20	7.2V	449.29860	-0.00009
-30	7.2V	449.29859	-0.00009

**Channel 03**

Reference Frequency: 469.73900 MHz			Limit: 0.00025%
Environment Temperature (°C)	Power Supply (DC)	Frequency deviation measured with time Elapse (10 minutes)	
		(MHz)	%
50	7.2V	469.73819	-0.00017
40	7.2V	469.73821	-0.00017
30	7.2V	469.73825	-0.00016
20	7.2V	469.73848	-0.00011
10	7.2V	469.73834	-0.00014
0	7.2V	469.73835	-0.00014
-10	7.2V	469.73824	-0.00017
-20	7.2V	469.73823	-0.00017
-30	7.2V	469.73820	-0.00017

## 10 CONDUCTED OUTPUT POWER

### 10.1 PROVISIONS APPLICABLE

Per FCC <<2.1046 and <<90.205: Maximum ERP is dependent upon the station's antenna HAAT and required service area.

### 10.2 TEST PROCEDURE

Measurements shall be made to establish the radio frequency power delivered by the transmitter the standard output termination. The power output shall be monitored and recorded and no adjustment shall be made to the transmitter after the test has begun, except as noted below:

If the power output is adjustable, measurements shall be made for the highest and lowest power levels.

Measurement with Spectrum Analyzer ESI 26 conducted, external power supply with 7.2V stabilized supply voltage.

### 10.3 TEST SETUP BLOCK DIAGRAM

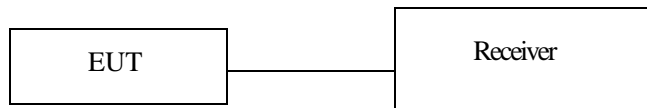

The EUT was directly connected to a RF Communication Test Set.

### 10.4 MEASUREMENT EQUIPMENT USED:

Open Area Test Site					
EQUIPMENT TYPE	MFR	MODEL NO.	SERIAL NO.	LAST CAL.	CAL DUE.
Receiver	ROHDE & SCHWARZ	ESI 26	100009	11/04/2005	11/05/2006
Attenuator	R&S	ESH3-22	100449	11/04/2005	11/05/2006

### 10.5 TEST RESULTS:

Product : FM Handheld Transceiver      Test Mode : CH1-430MHz  
Test Item : RF Output Power              Temperature : 25°C  
Test Voltage : DC 7.2V (External Power Supply)      Humidity : 56%RH  
Test Result : **PASS**

**CH1**

Freq. (MHz)	Measurement (dBm/Watt)	FCC Limit (Watt)
430.060	35.67/3.68	Varies

Product : FM Handheld Transceiver      Test Mode : CH2-450MHz  
Test Item : RF Output Power              Temperature : 25°C  
Test Voltage : DC 7.2V (External Power Supply)      Humidity : 56%RH  
Test Result : **PASS**

**CH2**

Freq. (MHz)	Measurement (dBm/Watt)	FCC Limit (Watt)
449.299	35.43/3.54	Varies

Product : FM Handheld Transceiver      Test Mode : CH3-470MHz  
Test Item : RF Output Power              Temperature : 25°C  
Test Voltage : DC 7.2V (External Power Supply)      Humidity : 56%RH  
Test Result : **PASS**

**CH3**

Freq. (MHz)	Measurement (dBm/Watt)	FCC Limit (Watt)
469.739	35.79/3.79	Varies

## 11. TRANSMITTER FREQUENCY BEHAVIOR

### 11.1 PROVISIONS APPLICABLE

#### Section 90.214

The transient periods are given in following table:

Frequency Range	30 MHz to 300 MHz	Above 300 MHz to 500 MHz	Above 500 MHz to 1000MHz
t <sub>1</sub> (ms)	5.0	10.0	20.0
t <sub>2</sub> (ms)	20.0	25.0	50.0
t <sub>3</sub> (ms)	5.0	10.0	10.0

00

### 11.2 TEST METHOD

TIA/EIA-603 2.2.19

### 11.3 TEST SETUP BLOCK DIAGRAM

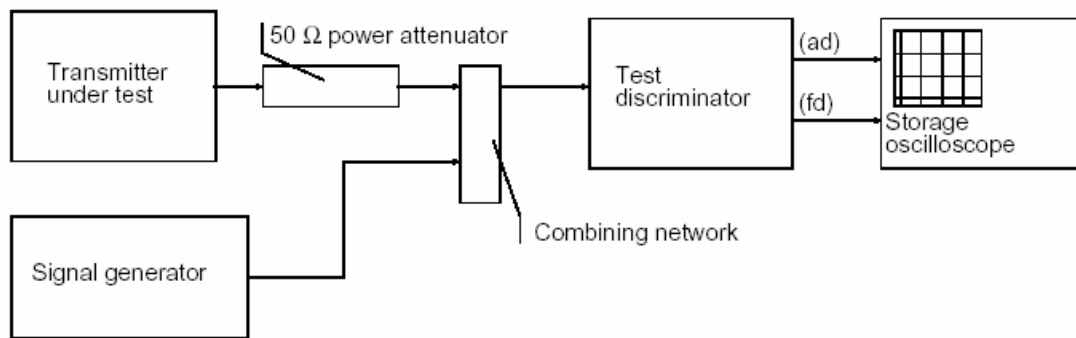

### 11.4 MEASUREMENT EQUIPMENT USED:

Name of Equipment	Manufacturer	Model	Serial Number	Calibration Due
Signal Generator	Rohde&Schwarz	SMT03	100059	02/01/2007
Storage Oscilloscope	Tektronix	TDS3052	B017447	06/28/2006

### 11.5 TEST RESULTS:

Please refer to the following plots.

Transmitter Frequency Behaviour @ 12.5 KHz Channel Separation-----Off – On

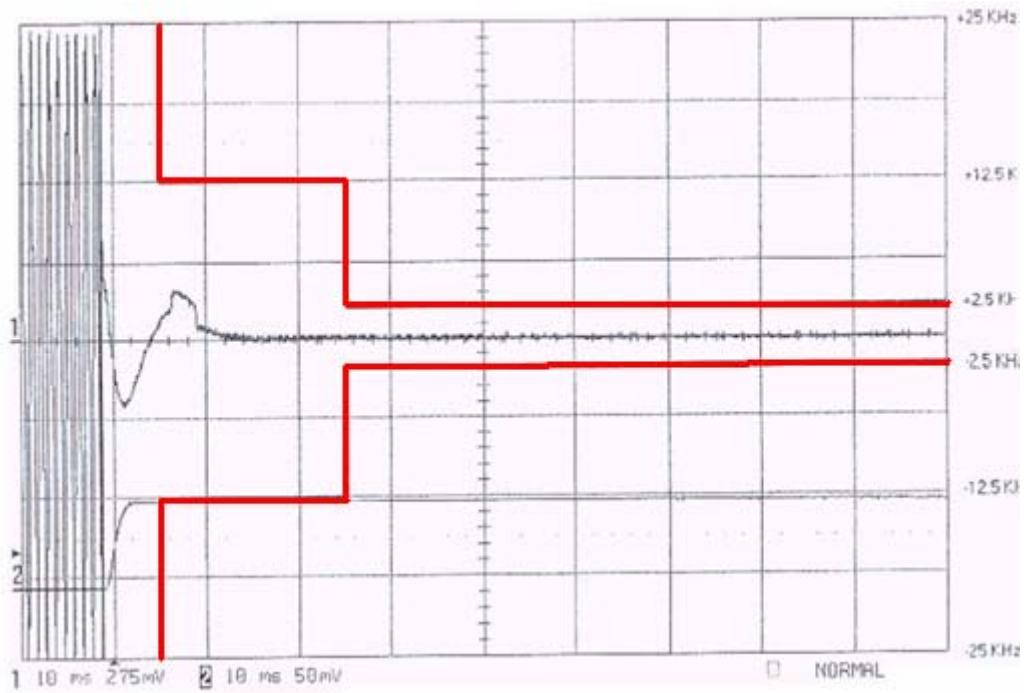

Transmitter Frequency Behaviour @ 12.5 KHz Channel Separation-----On - Off

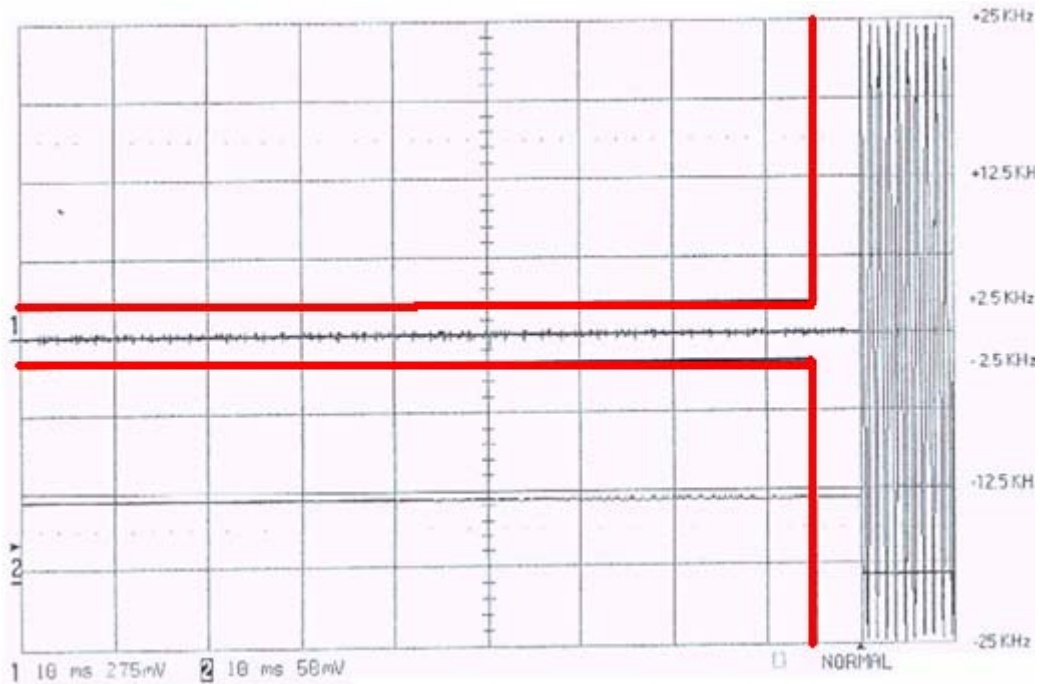



## **APPENDIX 1**

### **PHOTOGRAPHS OF TEST SETUP**

**Test Setup Photo-1**



**Test Setup Photo-2**

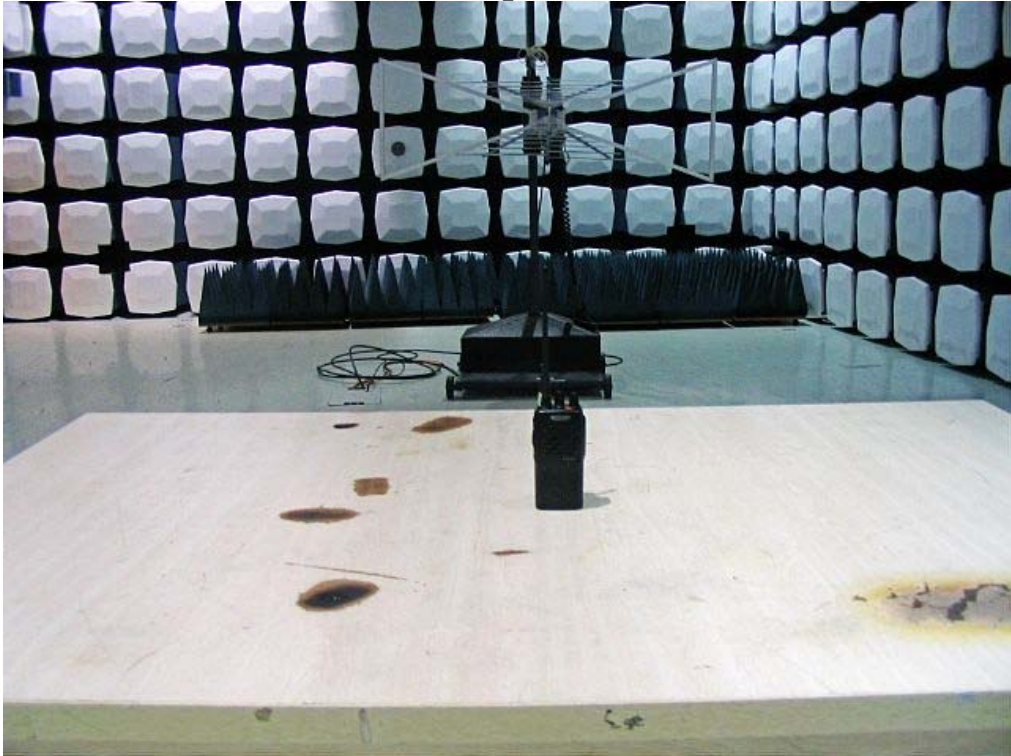

## **APPENDIX 2**

### **PHOTOGRAPHS OF EUT**

### Top view of EUT



### Bottom view of EUT



### Right view of EUT



### Left view of EUT



**Front view of EUT**



**Back view of EUT**



### Detached view of EUT-1



### Detached view of EUT-2



### Detached view of EUT-3

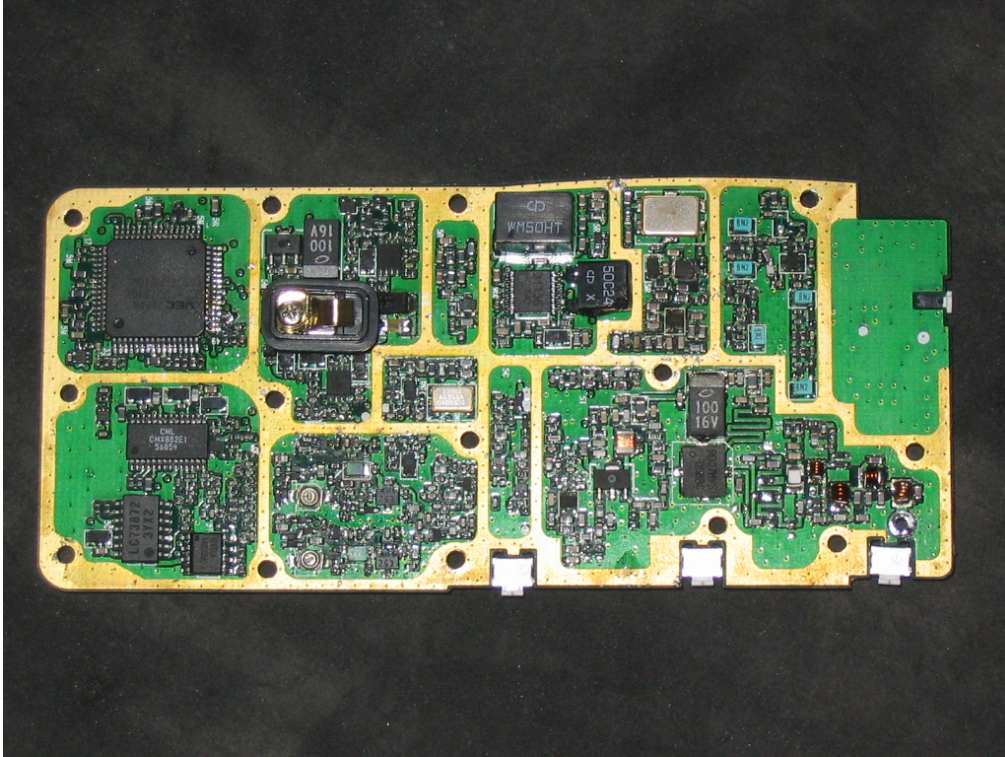

### Detached view of EUT-4

