



FCC 47 CFR PART 15 SUBPART C

TEST REPORT

For

Averatec Inc.

Notebook built-in b/g WLAN Module

Model: 3200 Series

Trade Name: Averatec

Prepared for

Averatec Inc.

80 Icon, Foothill Ranch, CA 92610

Prepared by

Compliance Certification Services Inc.

No. 81-1, Lane 210, Bade Rd. 2, Luchu Hsiang,

Taoyuan Hsien, (338) Taiwan, R.O.C.

TEL: 886-3-324-0332

FAX: 886-3-324-5235



Note: This report shall not be reproduced except in full, without the written approval of Compliance Certification Services Inc. This document may be altered or revised by Compliance Certification Services Inc. personnel only, and shall be noted in the revision section of the document.



TABLE OF CONTENTS

1. TEST RESULT CERTIFICATION.....3

2. EUT DESCRIPTION.....4

3. TEST METHODOLOGY5

 3.1 EUT CONFIGURATION5

 3.2 EUT EXERCISE.....5

 3.3 GENERAL TEST PROCEDURES.....5

 3.4 FCC PART 15.205 RESTRICTED BANDS OF OPERATIONS.....6

 3.5 DESCRIPTION OF TEST MODES6

4. INSTRUMENT CALIBRATION.....7

5. FACILITIES AND ACCREDITATIONS.....8

 5.1 FACILITIES 8

 5.2 EQUIPMENT.....8

 5.3 LABORATORY ACCREDITATIONS AND LISTING.....8

 5.4 TABLE OF ACCREDITATIONS AND LISTINGS.....9

6. SETUP OF EQUIPMENT UNDER TEST10

 6.1 SETUP CONFIGURATION OF EUT.....10

 6.2 SUPPORT EQUIPMENT10

7. FCC PART 15.247 REQUIREMENTS.....11

 7.1 6DB BANDWIDTH.....11

 7.2 PEAK POWER.....16

 7.3 BAND EDGES MEASUREMENT21

 7.4 PEAK POWER SPECTRAL DENSITY22

 7.5 RADIO FREQUENCY EXPOSURE32

 7.6 SPURIOUS EMISSIONS38

 7.7 POWERLINE CONDUCTED EMISSIONS.....60

APPENDIX 1 PHOTOGRPHS OF TEST SETUP.....63



1. TEST RESULT CERTIFICATION

Applicant: Averatec Inc.
80 Icon, Foothill Ranch, CA 92610

Equipment Under Test: Notebook built-in b/g WLAN Module

Trade Name: Averatec

Model: 3200 Series

Date of Test: May 6 ~ 10, 2004

APPLICABLE STANDARDS	
STANDARD	TEST RESULT
FCC Part 15 Subpart C	No non-compliance noted

We hereby certify that:

The above equipment was tested by Compliance Certification Services Inc. The test data, data evaluation, test procedures, and equipment configurations shown in this report were made in accordance with the procedures given in ANSI C63.4 and the energy emitted by the sample EUT tested as described in this report is in compliance with the requirements of FCC Rules Part 15.207, 15.209, 15.247.

The test results of this report relate only to the tested sample EUT identified in this report.

Approved by:

Reviewed by:

Harris W. Lai
Executive Vice President
Compliance Certification Services Inc.

James Lee
Section Manager
Compliance Certification Services Inc.



2. EUT DESCRIPTION

Product	Notebook built-in b/g WLAN Module
Trade Name	Averatec
Model Number	3200 Series
Model Discrepancy	N/A
Power Supply	Powered from the host device
Frequency Range	IEEE 802.11b,g: 2412 ~ 2462 MHz
Transmit Power	IEEE 802.11b: 18.91 dBm IEEE 802.11g: 17.61 dBm
Modulation Technique	IEEE 802.11b: DSSS (CCK; DQPSK; DBPSK) IEEE 802.11g: OFDM
Antenna Gain	0.66 dBi (Max)
Antenna Designation	PIFA Antenna

Note: This submittal(s) (test report) is intended for FCC ID: Q3X3200M filing to comply with Section 15.207, 15.209 and 15.247 of the FCC Part 15, Subpart C Rules.



3. TEST METHODOLOGY

The tests documented in this report were performed in accordance with ANSI C63.4 and FCC CFR 47 2.1046, 2.1047, 2.1049, 2.1051, 2.1053, 2.1055, 2.1057, 15.207, 15.209 and 15.247.

3.1 EUT CONFIGURATION

The EUT configuration for testing is installed on RF field strength measurement to meet the Commissions requirement and operating in a manner that intends to maximize its emission characteristics in a continuous normal application.

3.2 EUT EXERCISE

The EUT was operated in the engineering mode to fix the TX frequency that was for the purpose of the measurements.

According to its specifications, the EUT must comply with the requirements of the Section 15.207, 15.209 and 15.247 under the FCC Rules Part 15 Subpart C.

3.3 GENERAL TEST PROCEDURES

Conducted Emissions

The EUT is placed on the turntable, which is 0.8 m above ground plane. According to the requirements in Section 13.1.4.1 of ANSI C63.4 Conducted emissions from the EUT measured in the frequency range between 0.15 MHz and 30MHz using CISPR Quasi-peak and average detector modes.

Radiated Emissions

The EUT is placed on a turn table, which is 0.8 m above ground plane. The turntable shall rotate 360 degrees to determine the position of maximum emission level. EUT is set 3m away from the receiving antenna, which varied from 1m to 4m to find out the highest emission. And also, each emission was to be maximized by changing the polarization of receiving antenna both horizontal and vertical. In order to find out the max. emission, the relative positions of this hand-held transmitter (EUT) was rotated through three orthogonal axes according to the requirements in Section 13.1.4.1 of ANSI C63.4.

3.4 FCC PART 15.205 RESTRICTED BANDS OF OPERATIONS

(a) Except as shown in paragraph (d) of this section, only spurious emissions are permitted in any of the frequency bands listed below:

MHz	MHz	MHz	GHz
0.090 - 0.110	16.42 - 16.423	399.9 - 410	4.5 - 5.15
¹ 0.495 - 0.505	16.69475 - 16.69525	608 - 614	5.35 - 5.46
2.1735 - 2.1905	16.80425 - 16.80475	960 - 1240	7.25 - 7.75
4.125 - 4.128	25.5 - 25.67	1300 - 1427	8.025 - 8.5
4.17725 - 4.17775	37.5 - 38.25	1435 - 1626.5	9.0 - 9.2
4.20725 - 4.20775	73 - 74.6	1645.5 - 1646.5	9.3 - 9.5
6.215 - 6.218	74.8 - 75.2	1660 - 1710	10.6 - 12.7
6.26775 - 6.26825	108 - 121.94	1718.8 - 1722.2	13.25 - 13.4
6.31175 - 6.31225	123 - 138	2200 - 2300	14.47 - 14.5
8.291 - 8.294	149.9 - 150.05	2310 - 2390	15.35 - 16.2
8.362 - 8.366	156.52475 -	2483.5 - 2500	17.7 - 21.4
8.37625 - 8.38675	156.52525	2655 - 2900	22.01 - 23.12
8.41425 - 8.41475	156.7 - 156.9	3260 - 3267	23.6 - 24.0
12.29 - 12.293	162.0125 - 167.17	3332 - 3339	31.2 - 31.8
12.51975 - 12.52025	167.72 - 173.2	3345.8 - 3358	36.43 - 36.5
12.57675 - 12.57725	240 - 285	3600 - 4400	(²)
13.36 - 13.41	322 - 335.4		

¹ Until February 1, 1999, this restricted band shall be 0.490-0.510 MHz.

² Above 38.6

(b) Except as provided in paragraphs (d) and (e), the field strength of emissions appearing within these frequency bands shall not exceed the limits shown in Section 15.209. At frequencies equal to or less than 1000 MHz, compliance with the limits in Section 15.209 shall be demonstrated using measurement instrumentation employing a CISPR quasi-peak detector. Above 1000 MHz, compliance with the emission limits in Section 15.209 shall be demonstrated based on the average value of the measured emissions. The provisions in Section 15.35 apply to these measurements.

3.5 DESCRIPTION OF TEST MODES

The EUT has been tested under operating condition.

Software used to control the EUT for staying in continuous transmitting and receiving mode is programmed.

IEEE802.11b: Channel 1(2412MHz), Channel 6(2437MHz) and Channel 11(2462MHz) with 11Mbps highest data rate (worst case) are chosen for the final testing.

IEEE802.11g: Channel 1(2412MHz), Channel 6(2437MHz) and Channel 11(2462MHz) with 6Mbps data rate (the worst case) are chosen for the final testing.



4. INSTRUMENT CALIBRATION

The measuring equipment, which was utilized in performing the tests documented herein, has been calibrated in accordance with the manufacturer's recommendations for utilizing calibration equipment, which is traceable to recognized national standards.



5. FACILITIES AND ACCREDITATIONS

5.1 FACILITIES

All measurement facilities used to collect the measurement data are located at

No. 81-1, Lane 210, Bade Rd. 2, Luchu Hsiang, Taoyuan Hsien, Taiwan, R.O.C.

No. 199, Chungsen Road, Hsintien City, Taipei Hsien, Taiwan, R.O.C.

The sites are constructed in conformance with the requirements of ANSI C63.7, ANSI C63.4 and CISPR Publication 22.

5.2 EQUIPMENT

Radiated emissions are measured with one or more of the following types of linearly polarized antennas: tuned dipole, biconical, log periodic, bi-log, and/or ridged waveguide, horn. Spectrum analyzers with pre-selectors and quasi-peak detectors are used to perform radiated measurements.

Conducted emissions are measured with Line Impedance Stabilization Networks and EMI Test Receivers.







Calibrated wideband preamplifiers, coaxial cables, and coaxial attenuators are also used for making measurements.

All receiving equipment conforms to CISPR Publication 16-1, "Radio Interference Measuring Apparatus and Measurement Methods."

5.3 LABORATORY ACCREDITATIONS AND LISTING

The test facilities used to perform radiated and conducted emissions tests are accredited by National Voluntary Laboratory Accreditation Program for the specific scope of accreditation under Lab Code: 200600-0 to perform Electromagnetic Interference tests according to FCC PART 15 AND CISPR 22 requirements. No part of this report may be used to claim or imply product endorsement by NVLAP or any agency of the US Government. In addition, the test facilities are listed with Federal Communications Commission (Registration no: 93105 and 90471).

5.4 TABLE OF ACCREDITATIONS AND LISTINGS

Country	Agency	Scope of Accreditation	Logo
USA	NVLAP*	EN 55011, EN 55014-1, AS/NZS 1044, CNS 13783-1, EN 55022, CNS 13438, EN 61000-3-2, EN 61000-3-3, ANSI C63.4, FCC OST/MP-5, AS/NZS CISPR 22, IEC 61000-4-2, IEC 61000-4-3, IEC 61000-4-4, IEC 61000-4-5, IEC 61000-4-6, IEC 61000-4-8, IEC 61000-4-11	 200600-0
USA	FCC	3/10 meter Open Area Test Sites to perform FCC Part 15/18 measurements	 93105, 90471
Japan	VCCI	4 3/10 meter Open Area Test Sites to perform conducted/radiated measurements	 R-393/1066/725/879 C-402/747/912
Norway	NEMKO	EN 50081-1/2, EN 50082-1/2, IEC 61000-6-1/2, EN 50091-2, EN 50130-4, EN 55011, EN 55013, EN 55014-1/2, EN 55015, EN 55022, EN 55024, EN 61000-3-2/3, EN 61326-1, IEC 61000-4-2/3/4/5/6/8/11, EN 60601-1-2, EN 300 328-2, EN 300 422-2, EN 301 419-1, EN 301 489-01/03/07/08/09/17, EN 301 419-2/3, EN 300 454-2, EN 301 357-2	 ELA 124a ELA 124b ELA 124c
Taiwan	CNLA	EN 300 328-1/2, EN 300 220-1/2/3, EN 300 440-1/2, EN 61000-3-2, EN 61000-3-3, 47 CFR FCC Part 15 Subpart C/D/E, EN 55013, CNS 13439, EN 55014-1, CNS 13783-1, EN 55022, CNS 13438, CISPR 22, AS/NZS 3548, EN 61000-4-2/3/4/5/6/8/11, ENV 50204, IEEE Std 1528, FCC OET Bulletin, 65+Supplement C, EN50360, EN50361, EN50371, RSS102	 0363 ILAC MRA
Taiwan	BSMI	CNS 13438, CNS 13783-1, CNS 13439, CNS 14115	 SL2-IS-E-0014 SL2-IN-E-0014 SL2-A1-E-0014 SL2-R1-E-0014 SL2-R2-E-0014 SL2-L1-E-0014
Canada	Industry Canada	RSS212, Issue 1	 IC 3991-3 IC 3991-4

* No part of this report may be used to claim or imply product endorsement by NVLAP or any agency of the US Government.



6. SETUP OF EQUIPMENT UNDER TEST

6.1 SETUP CONFIGURATION OF EUT

See test photographs attached in Appendix 1 for the actual connections between EUT and support equipment.

6.2 SUPPORT EQUIPMENT

Device Type	Brand	Model	FCC ID	Series No.	Data Cable	Power Cord
USB Mouse	HP	MO19UCA	FCC DoC	020440964	Shielded, 1.8m	N/A
USB Keyboard	IBM	KU-9958	FCC DoC	0004195	Shielded, 1.8m	N/A

Notes:

- 1. All the equipment/cables were placed in the worst-case configuration to maximize the emission during the test.*
- 2. Grounding was established in accordance with the manufacturer's requirements and conditions for the intended use.*

7. FCC PART 15.247 REQUIREMENTS

7.1 6dB BANDWIDTH

LIMIT

For the direct sequence systems, the minimum 6dB bandwidth shall be at least 500kHz.

MEASUREMENT EQUIPMENT USED

Name of Equipment	Manufacturer	Model	Serial Number	Calibration Due
Spectrum Analyzer	Agilent	E4446A	MY43360131	01/10/2005

Remark: Each piece of equipment is scheduled for calibration once a year.

Test Configuration

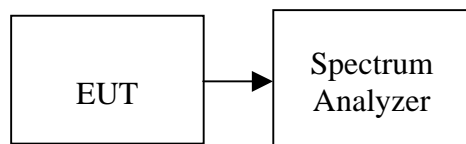

TEST PROCEDURE

1. Place the EUT on the table and set it in the transmitting mode.
2. Remove the antenna from the EUT and then connect a low loss RF cable from the antenna port to the spectrum analyzer.
3. Set the spectrum analyzer as RBW = 100kHz, VBW = RBW, Span = 20MHz, Sweep = auto.
4. Mark the peak frequency and -6dB (upper and lower) frequency.
5. Repeat until all the rest channels are investigated.



TEST RESULTS

No non-compliance noted

Test Data

Test mode: IEEE 802.11b

Channel	Frequency (MHz)	Bandwidth (kHz)	Limit (kHz)	Margin (kHz)
Low	2412	12200	>500	PASS
Mid	2437	12170		PASS
High	2462	12170		PASS

Test mode: IEEE 802.11g

Channel	Frequency (MHz)	Bandwidth (kHz)	Limit (kHz)	Margin (kHz)
Low	2412	16630	>500	PASS
Mid	2437	16630		PASS
High	2462	16630		PASS



Test Plot

802.11b mode

6dB Bandwidth (CH Low)

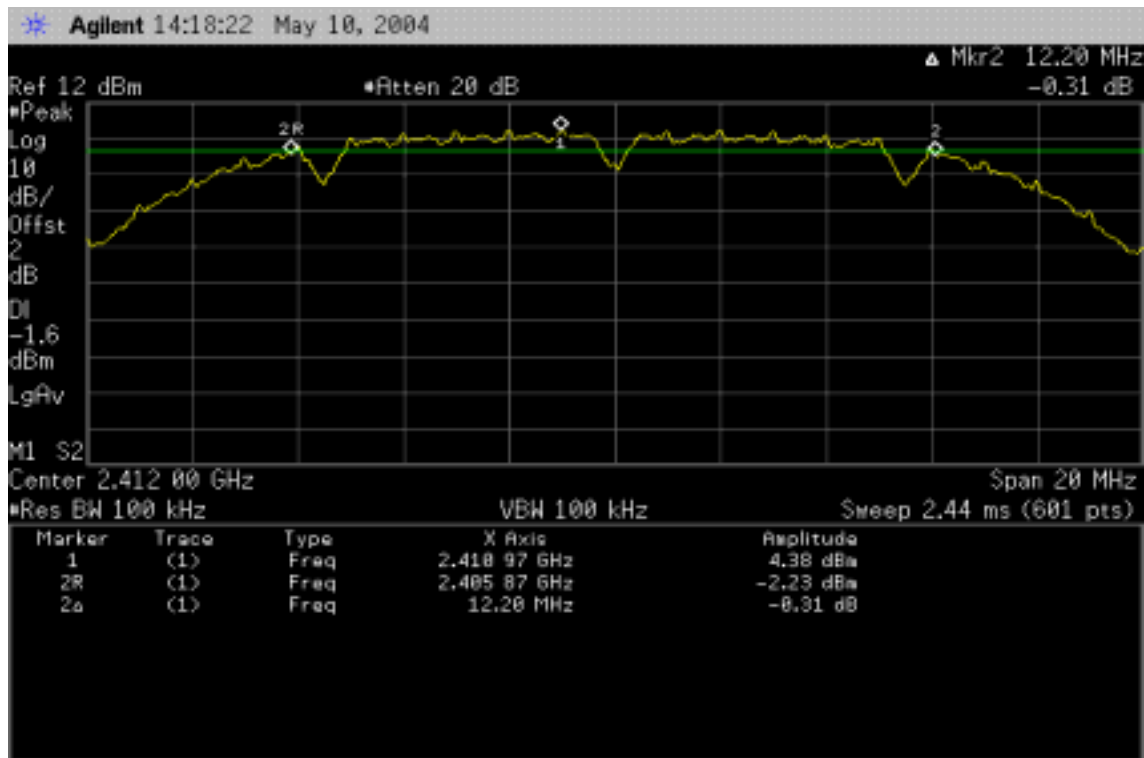

6dB Bandwidth (CH Mid)

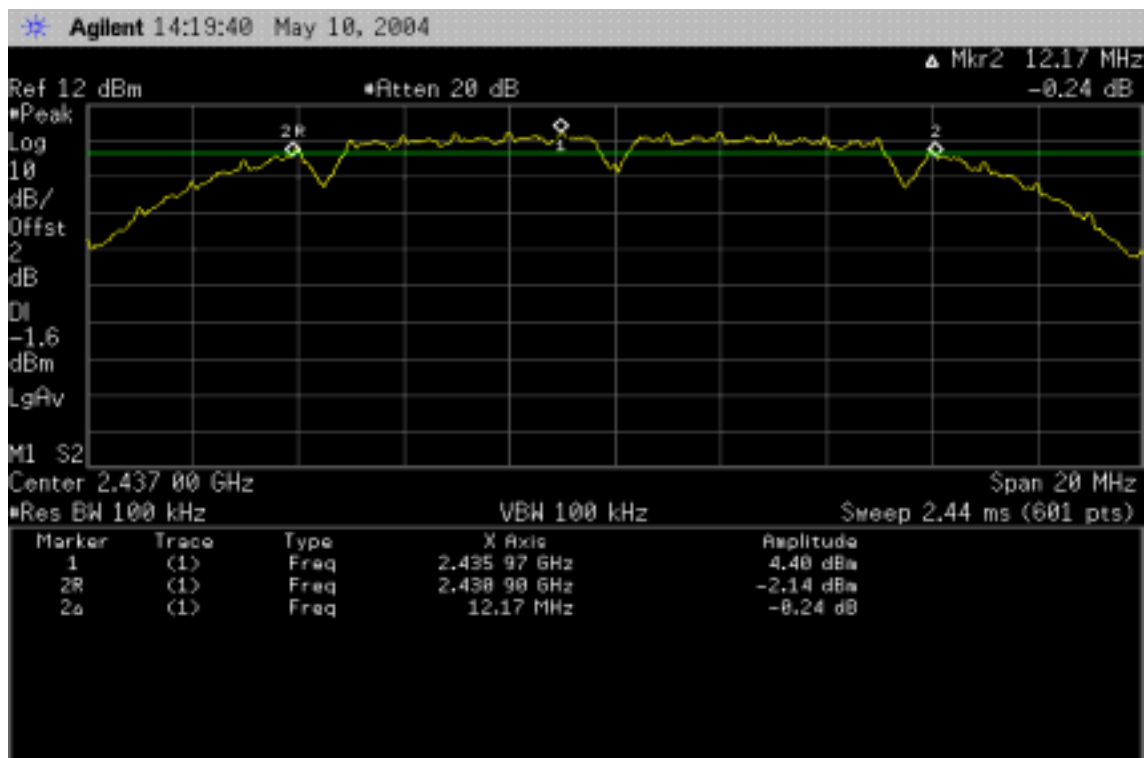



6dB Bandwidth (CH High)

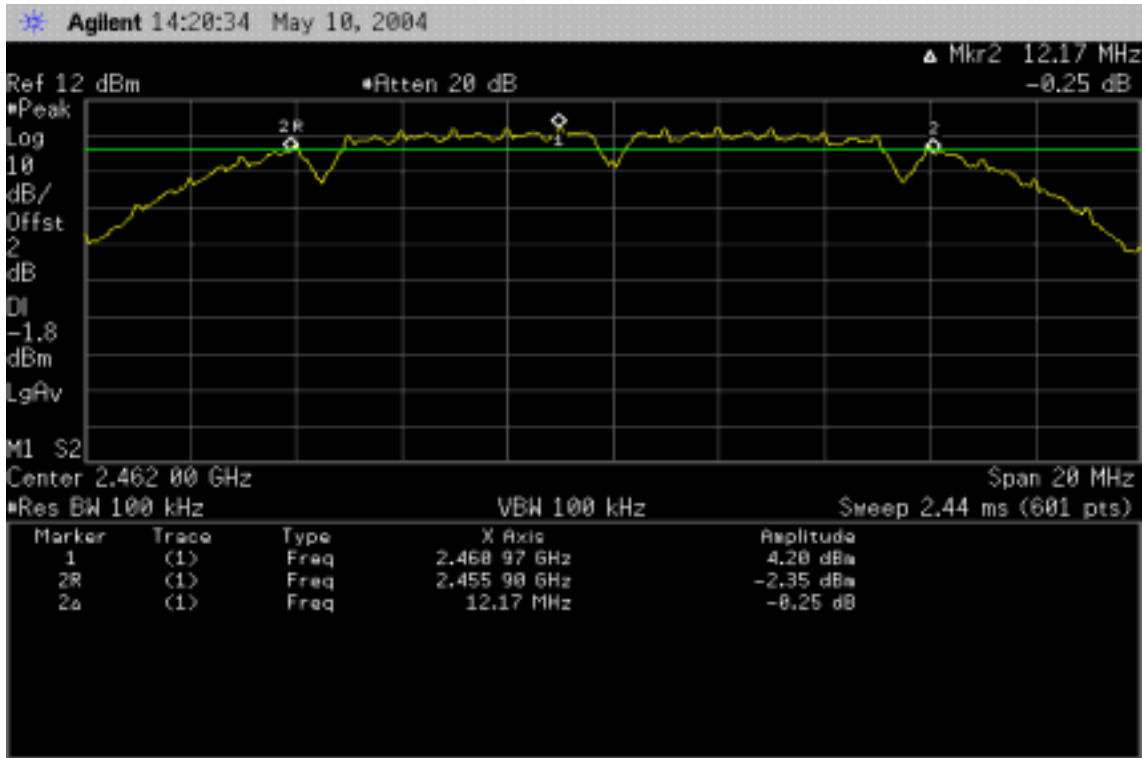

802.11g mode

6dB Bandwidth (CH Low)

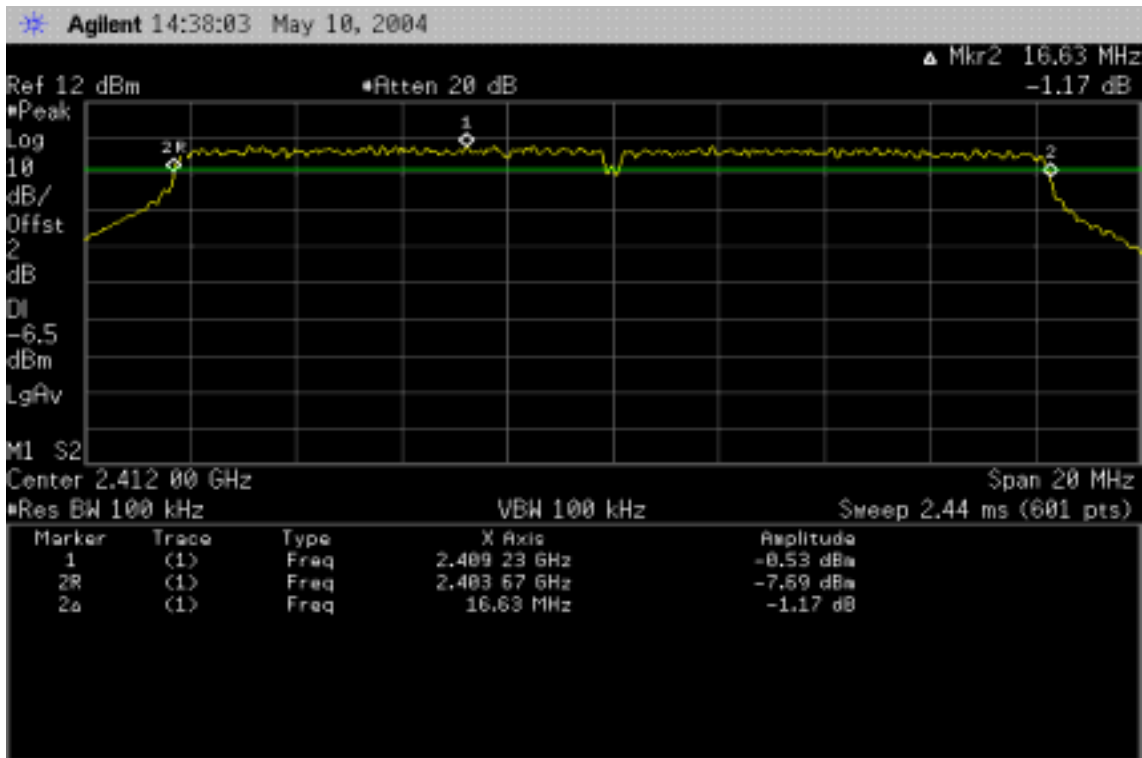



6dB Bandwidth (CH Mid)

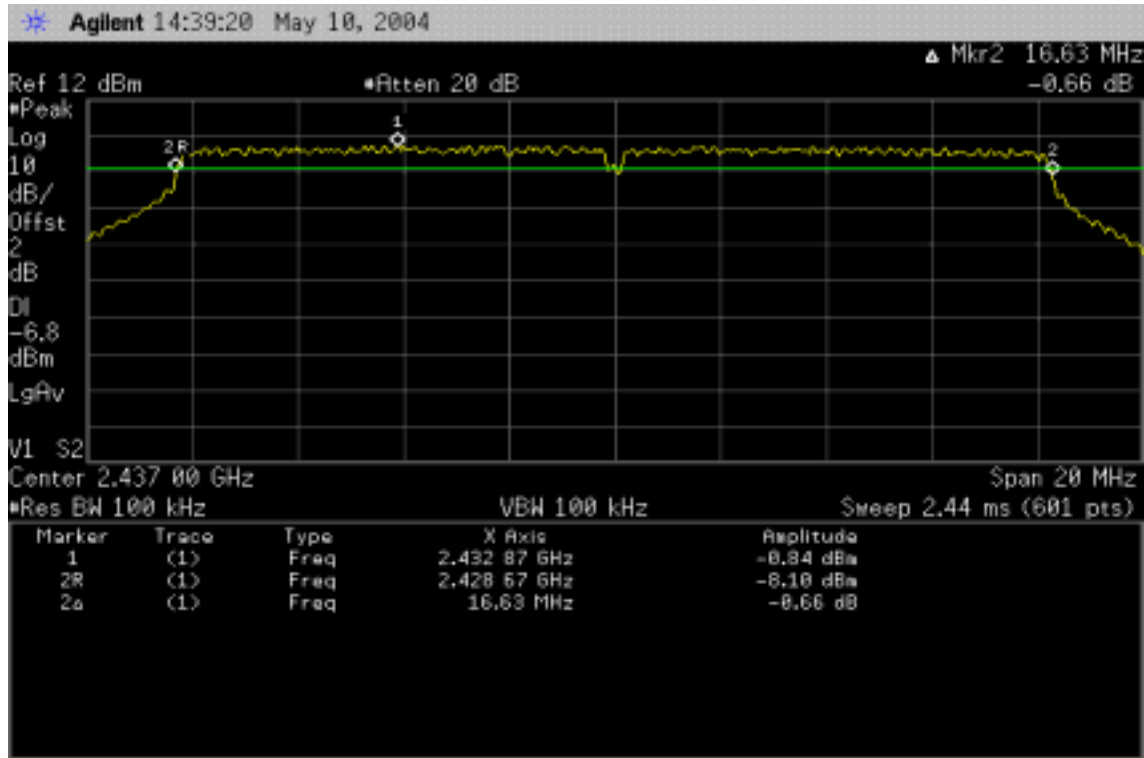

6dB Bandwidth (CH High)

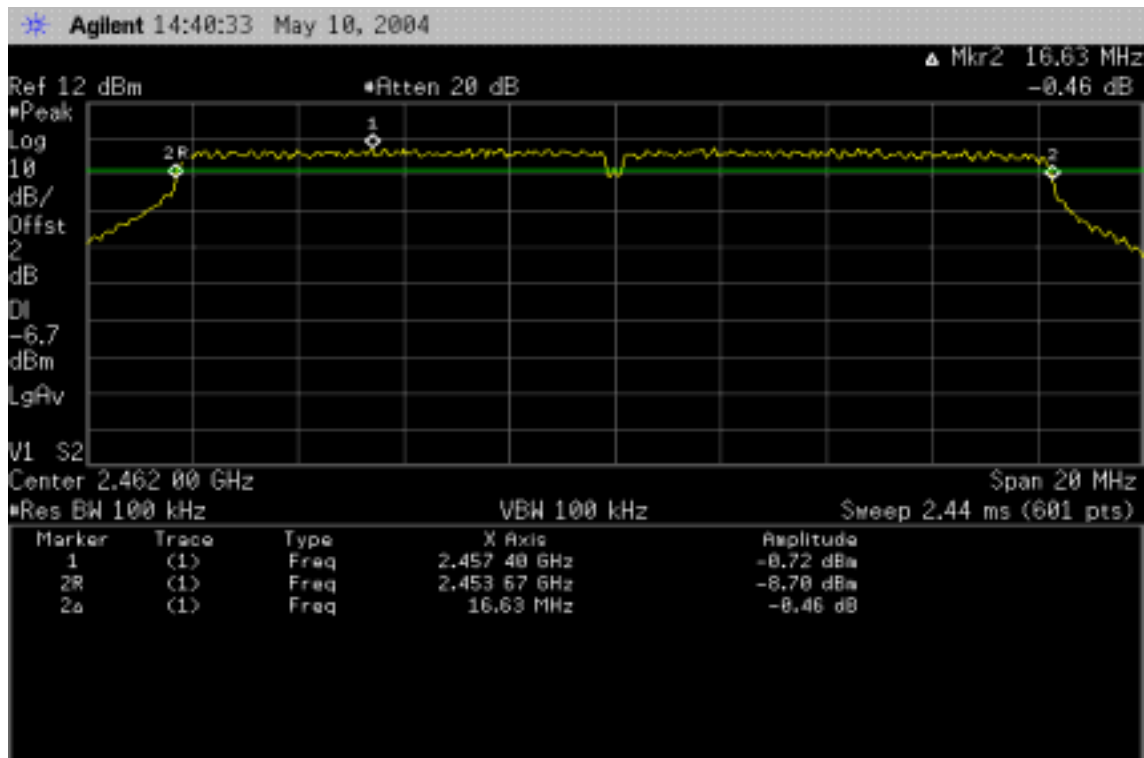

7.2 PEAK POWER

LIMIT

The maximum peak output power of the intentional radiator shall not exceed the following:

1. For systems using digital modulation in the bands of 902-928 MHz, 2400-2483.5 MHz, and 5725-5850 MHz: 1 watt.
2. Except as shown in paragraphs (b)(3) (i), (ii) and (iii) of this section, if transmitting antennas of directional gain greater than 6 dBi are used the peak output power from the intentional radiator shall be reduced below the stated values in paragraphs (b)(1) or (b)(2) of this section, as appropriate, by the amount in dB that the directional gain of the antenna exceeds 6 dBi.

MEASUREMENT EQUIPMENT USED

Name of Equipment	Manufacturer	Model	Serial Number	Calibration Due
Spectrum Analyzer	Agilent	E4446A	MY43360131	01/10/2005

Remark: Each piece of equipment is scheduled for calibration once a year.

Test Configuration

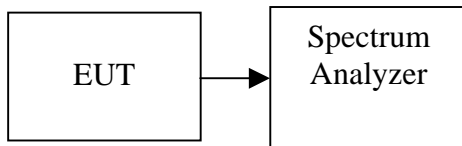

TEST PROCEDURE

The transmitter output is connected to the Spectrum analyzer. The Spectrum analyzer is set to the peak power detection.



TEST RESULTS

No non-compliance noted

Test Data

Test mode: IEEE 802.11b

Channel	Frequency (MHz)	Output Power (dBm)	Factor (dB)	Output Power (dBm)	Output Power (W)	Limit (W)	Result
Low	2412.00	16.91	2.00	18.91	0.07780	1	PASS
Mid	2437.00	16.85	2.00	18.85	0.07674		PASS
High	2462.00	16.45	2.00	18.45	0.06998		PASS

Test mode: IEEE 802.11g

Channel	Frequency (MHz)	Output Power (dBm)	Factor (dB)	Output Power (dBm)	Output Power (W)	Limit (W)	Result
Low	2412.00	15.61	2.00	17.61	0.05768	1	PASS
Mid	2437.00	15.50	2.00	17.50	0.05623		PASS
High	2462.00	15.48	2.00	17.48	0.05598		PASS

Test Plot

802.11b mode

Peak power (CH Low)

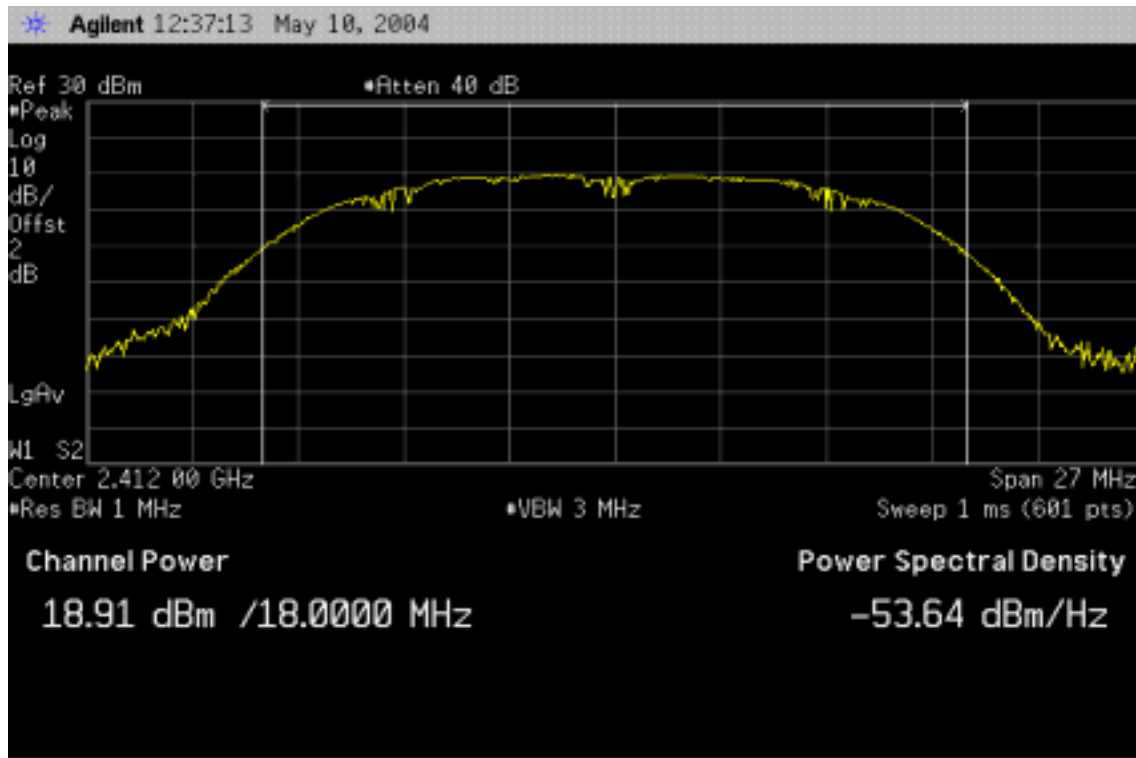

Peak power (CH Mid)

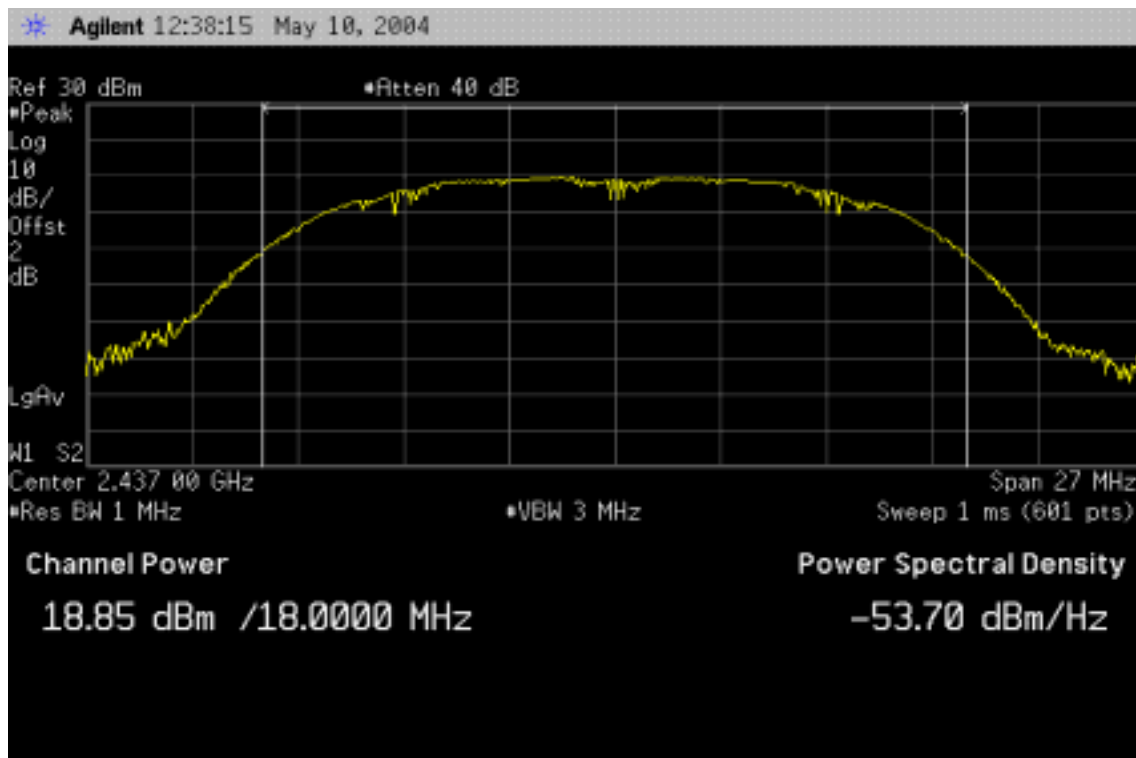



Peak power (CH High)

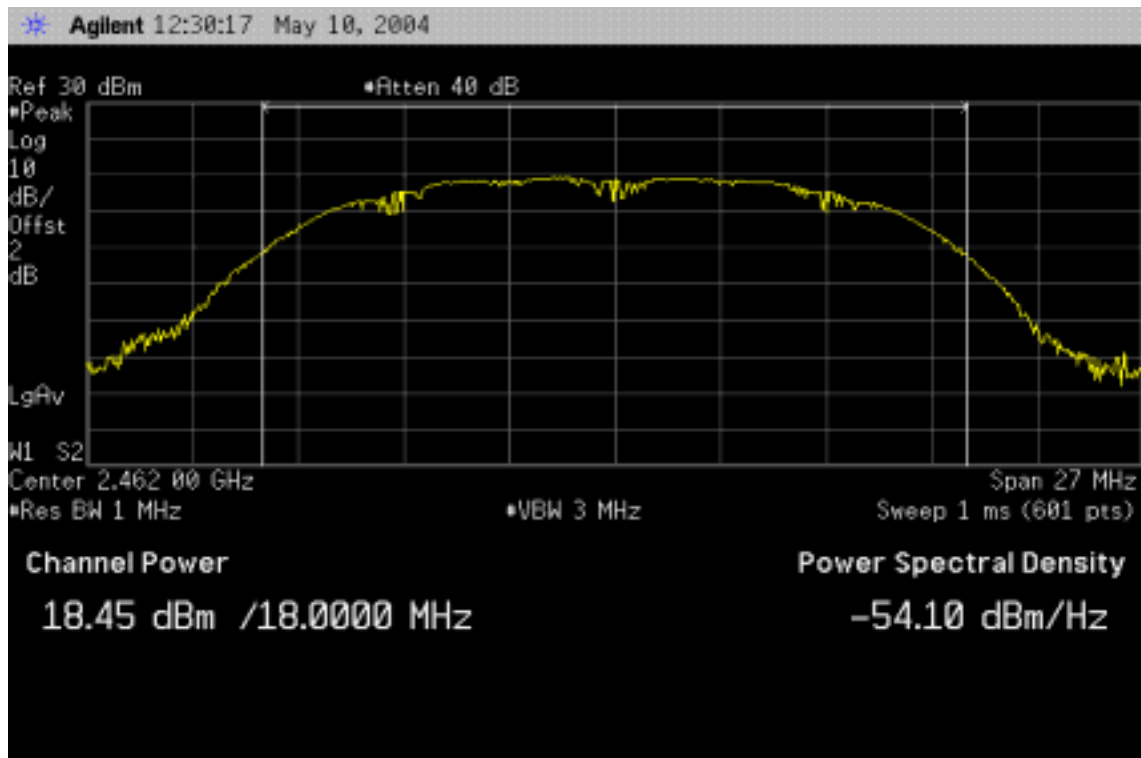

802.11g mode

Peak power (CH Low)

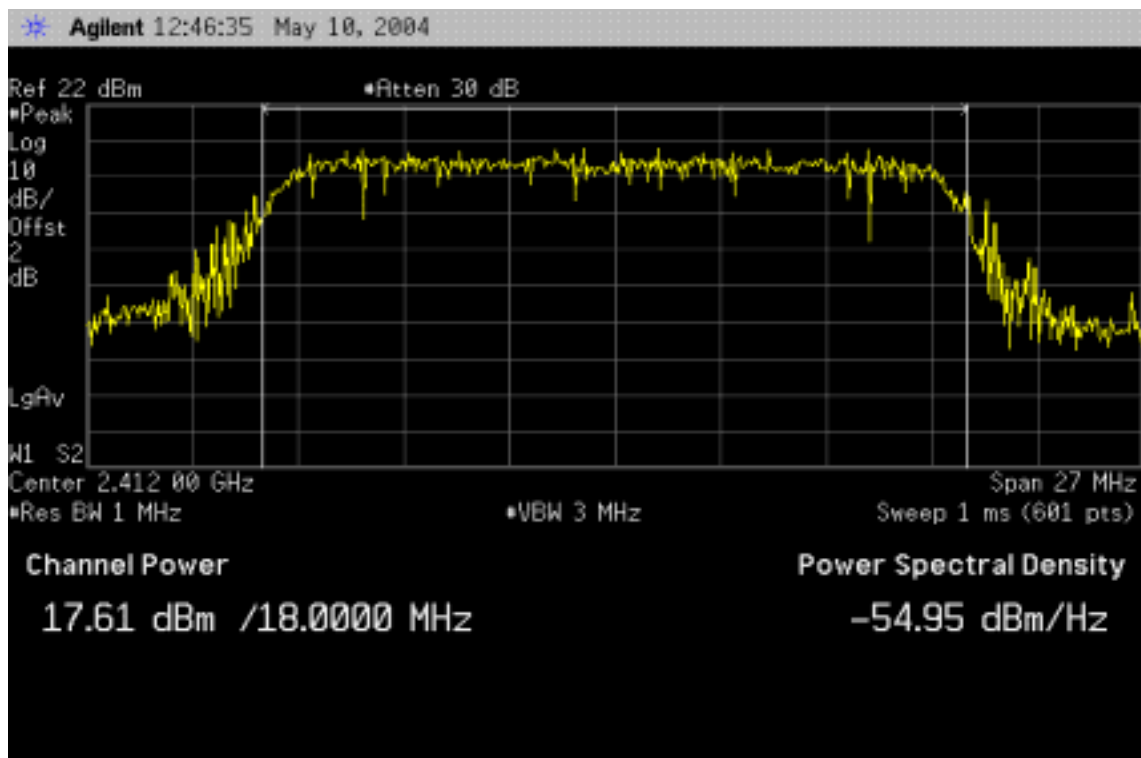



Peak power (CH Mid)

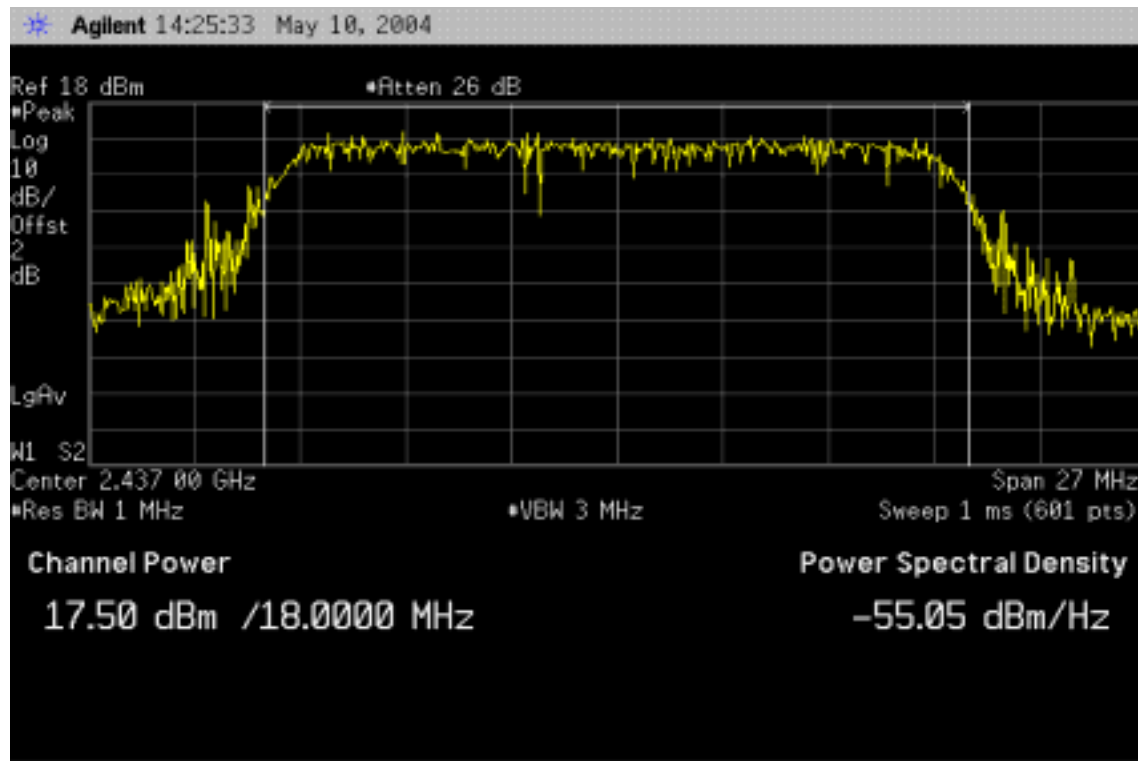

Peak power (CH High)

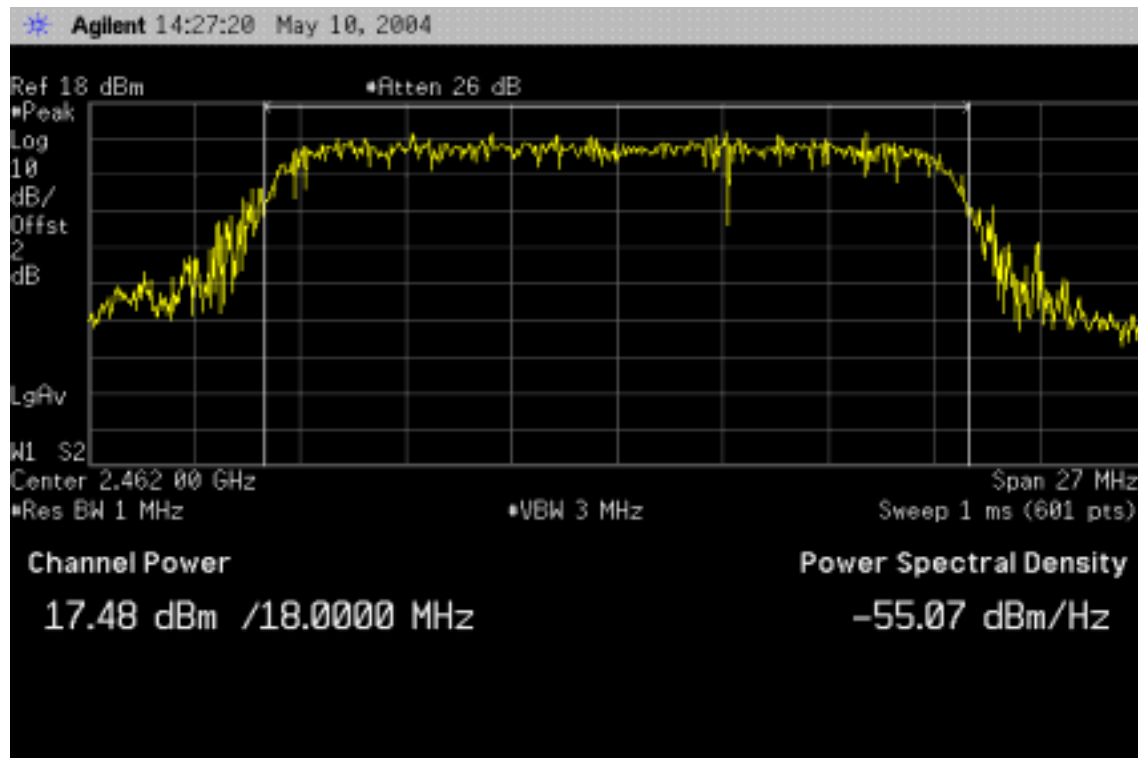

7.3 BAND EDGES MEASUREMENT

LIMIT

According to §15.247(c), in any 100 kHz bandwidth outside the frequency bands in which the spread spectrum intentional radiator is operating, the radio frequency power that is produced by the intentional radiator shall be at least 20dB below that in the 100kHz bandwidth within the band that contains the highest level of the desired power. In addition, radiated emissions which fall in the restricted bands, as defined in §15.205(a), must also comply with the radiated emission limits specified in §15.209(a).

MEASUREMENT EQUIPMENT USED

Name of Equipment	Manufacturer	Model	Serial Number	Calibration Due
Spectrum Analyzer	Agilent	E4446A	MY43360131	04/28/2004

Remark: Each piece of equipment is scheduled for calibration once a year.

Test Configuration

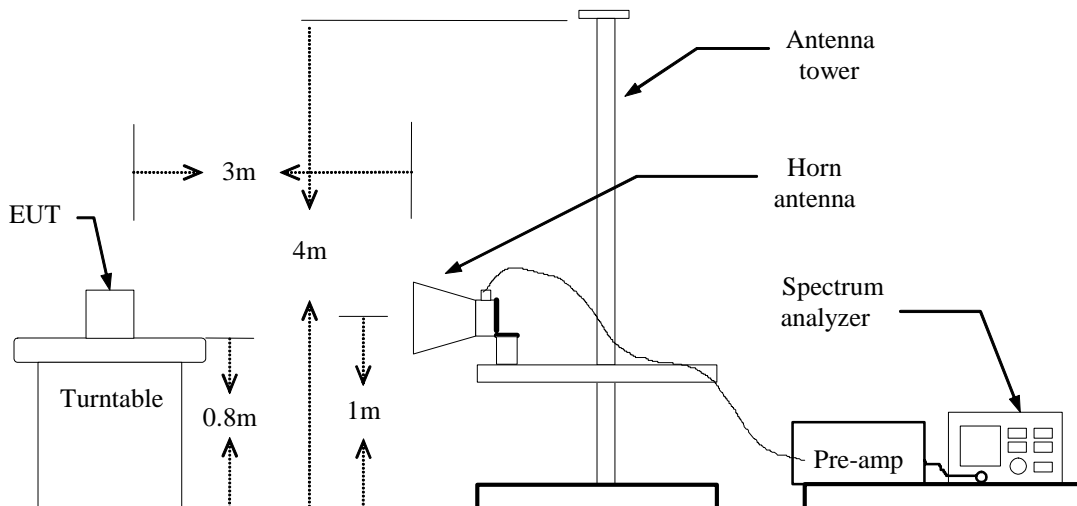

TEST PROCEDURE

1. The EUT is placed on a turntable, which is 0.8m above the ground plane.
2. The turntable shall be rotated for 360 degrees to determine the position of maximum emission level.
3. EUT is set 3m away from the receiving antenna, which is varied from 1m to 4m to find out the highest emission.
4. Set the spectrum analyzer in the following setting in order to capture the lower and upper band-edges of the emission:
 - (a) PEAK: RBW=VBW=1MHz / Sweep=AUTO
 - (b) AVERAGE: RBW=1MHz / VBW=10Hz / Sweep=AUTO
5. Repeat the procedures until all the PEAK and AVERAGE versus POLARIZATION are measured.

TEST RESULTS

Refer to attach spectrum analyzer data chart.



Band Edges (802.11b / CH Low)

Detector mode: Peak

Polarity: Vertical

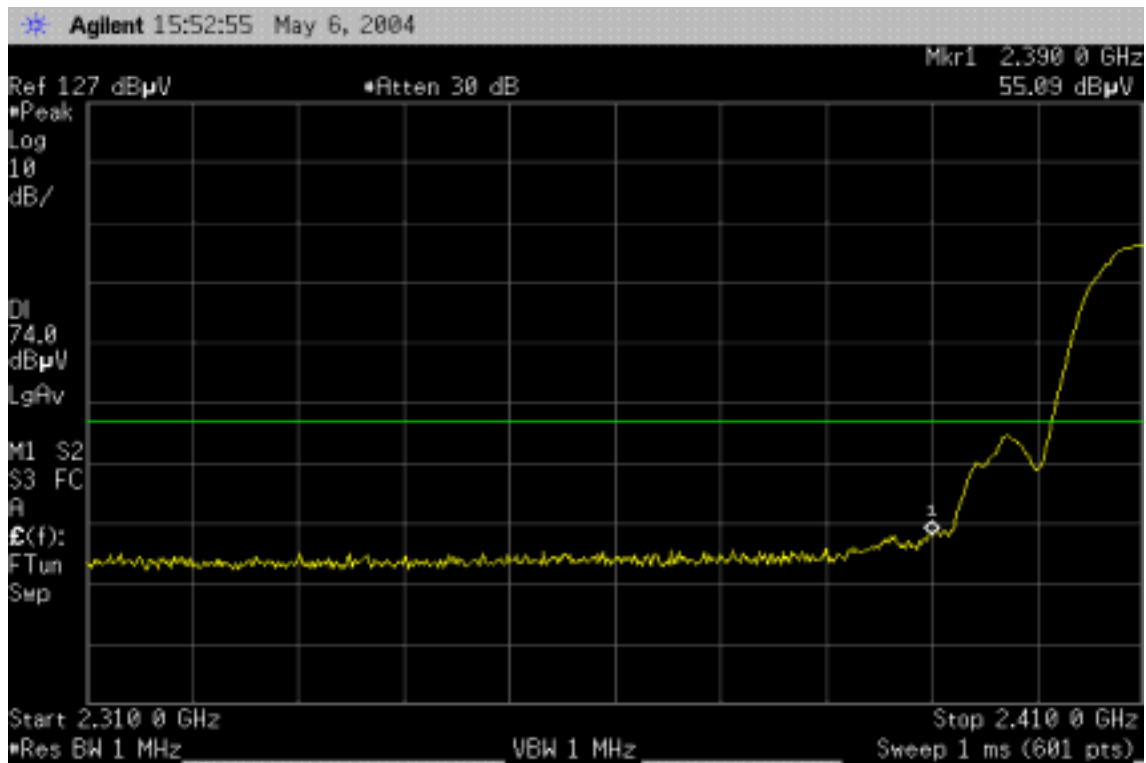

Detector mode: Average

Polarity: Vertical





Detector mode: Peak

Polarity: Horizontal

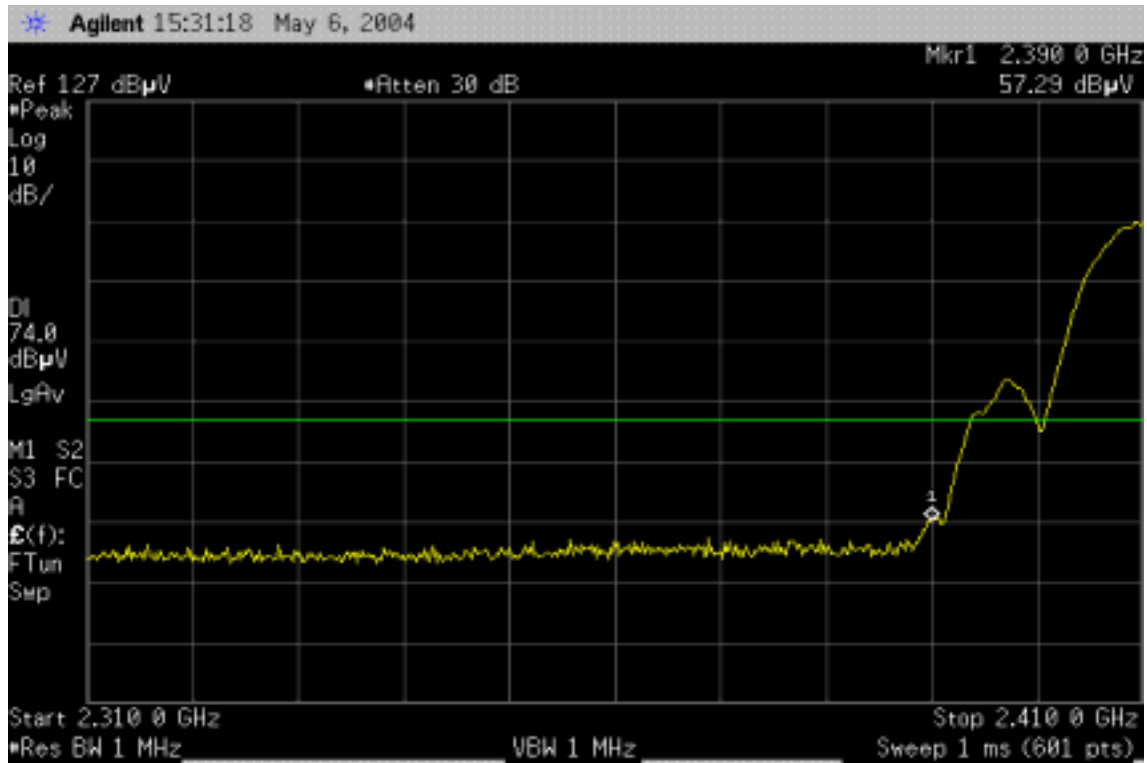

Detector mode: Average

Polarity: Horizontal

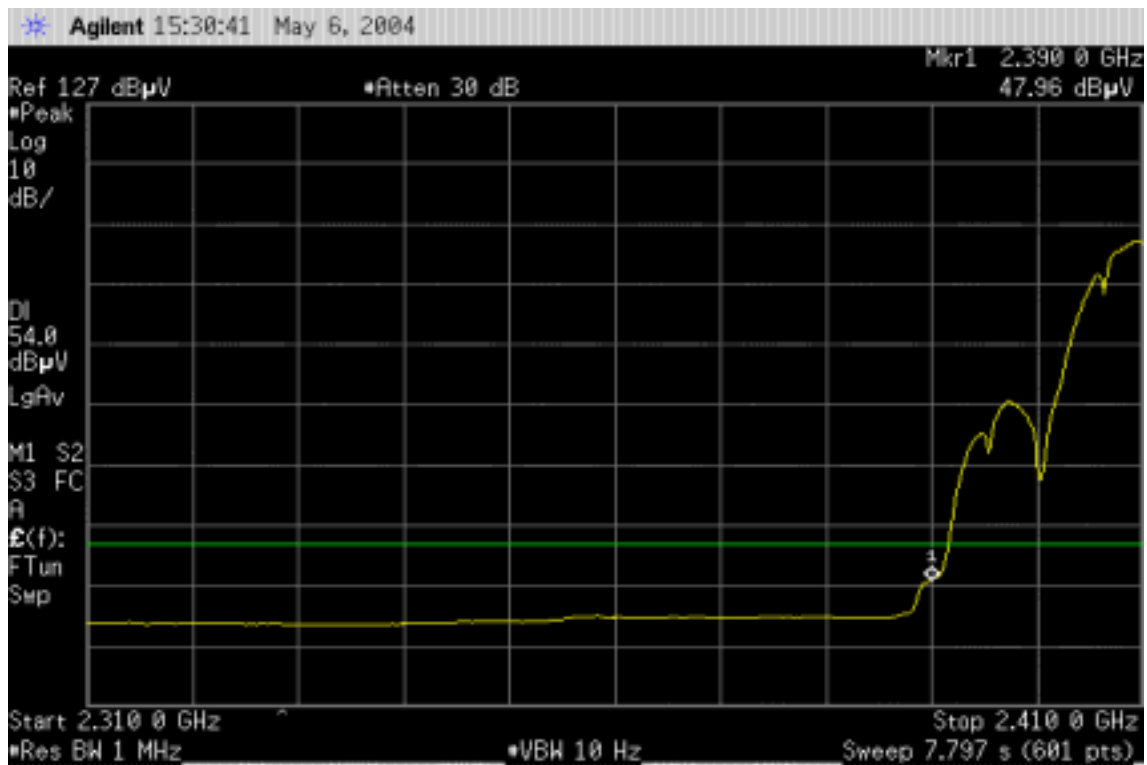



Band Edges (802.11b / CH High)

Detector mode: Peak

Polarity: Vertical

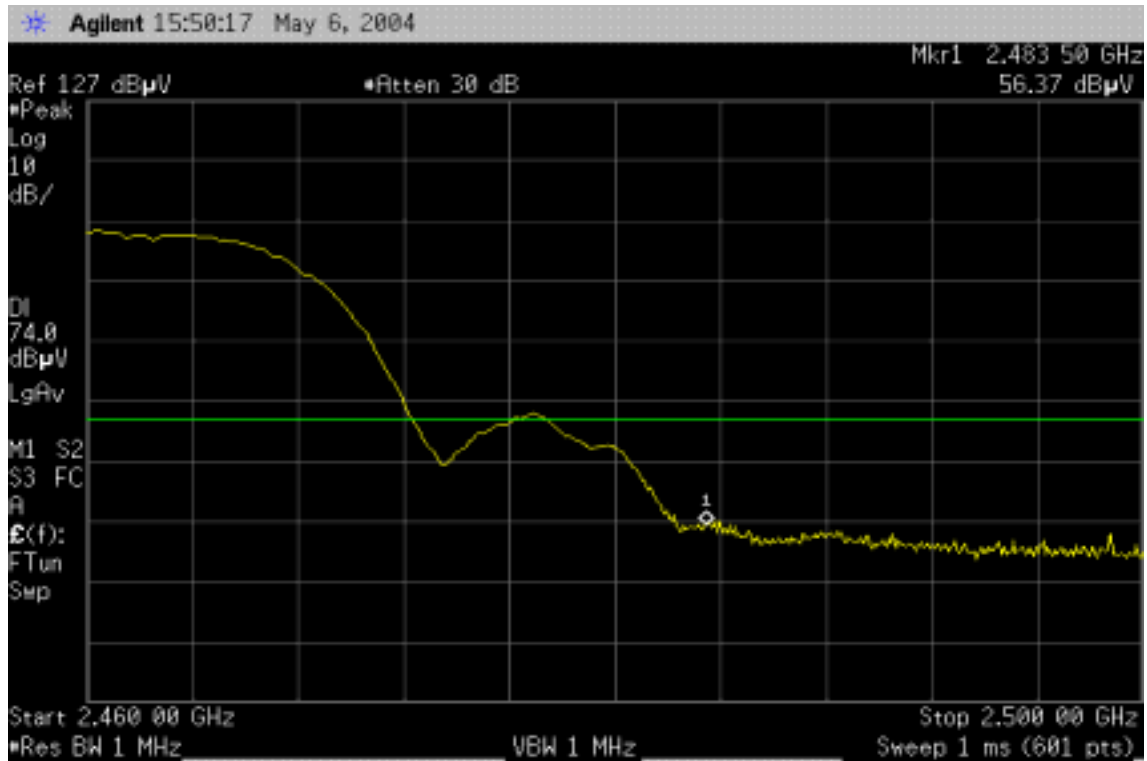

Detector mode: Average

Polarity: Vertical

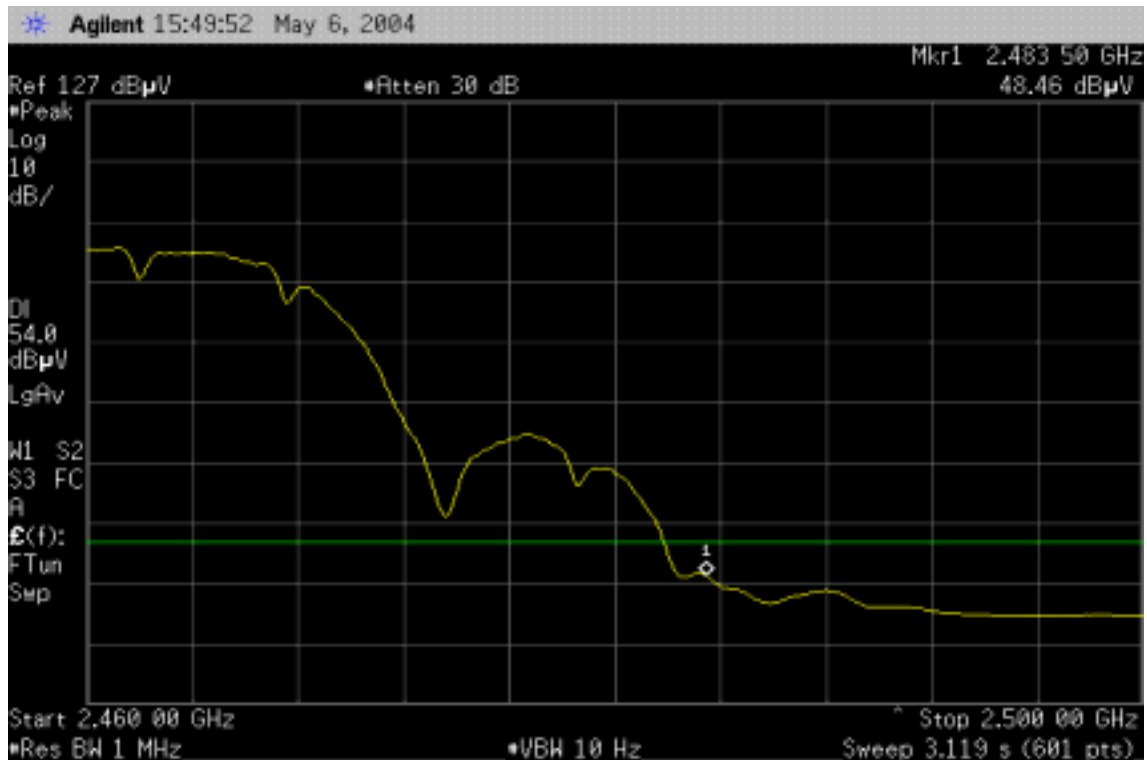



Detector mode: Peak

Polarity: Horizontal

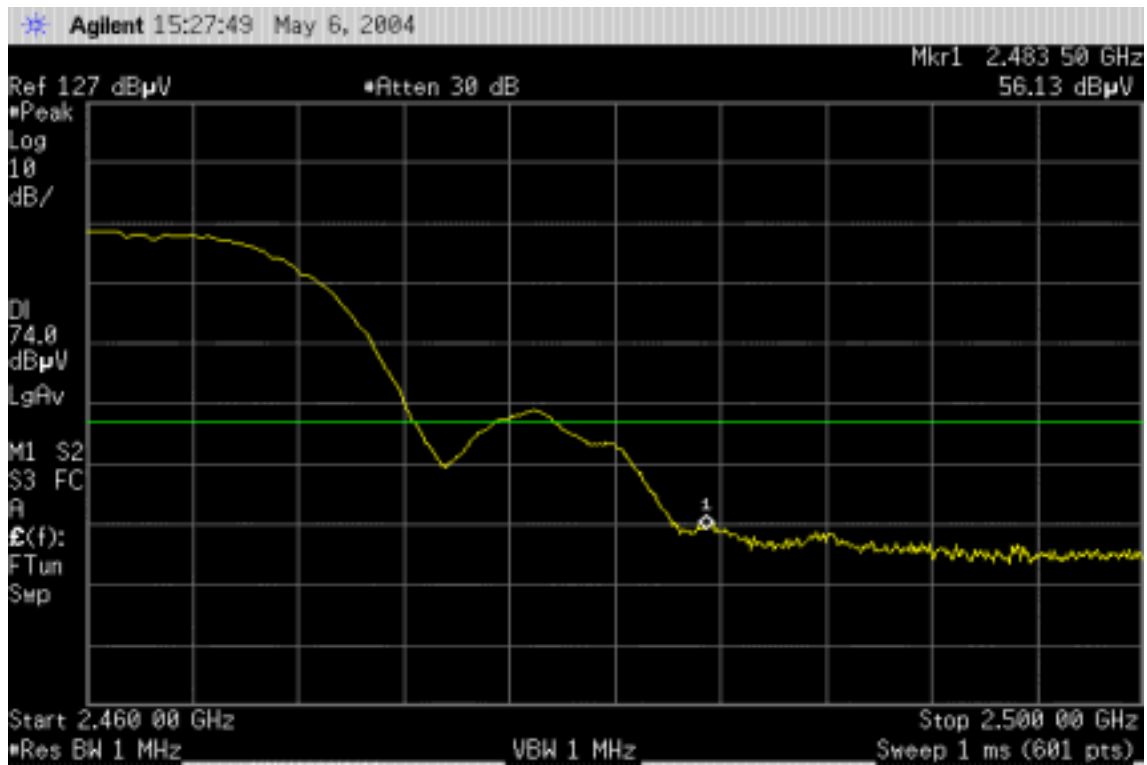

Detector mode: Average

Polarity: Horizontal

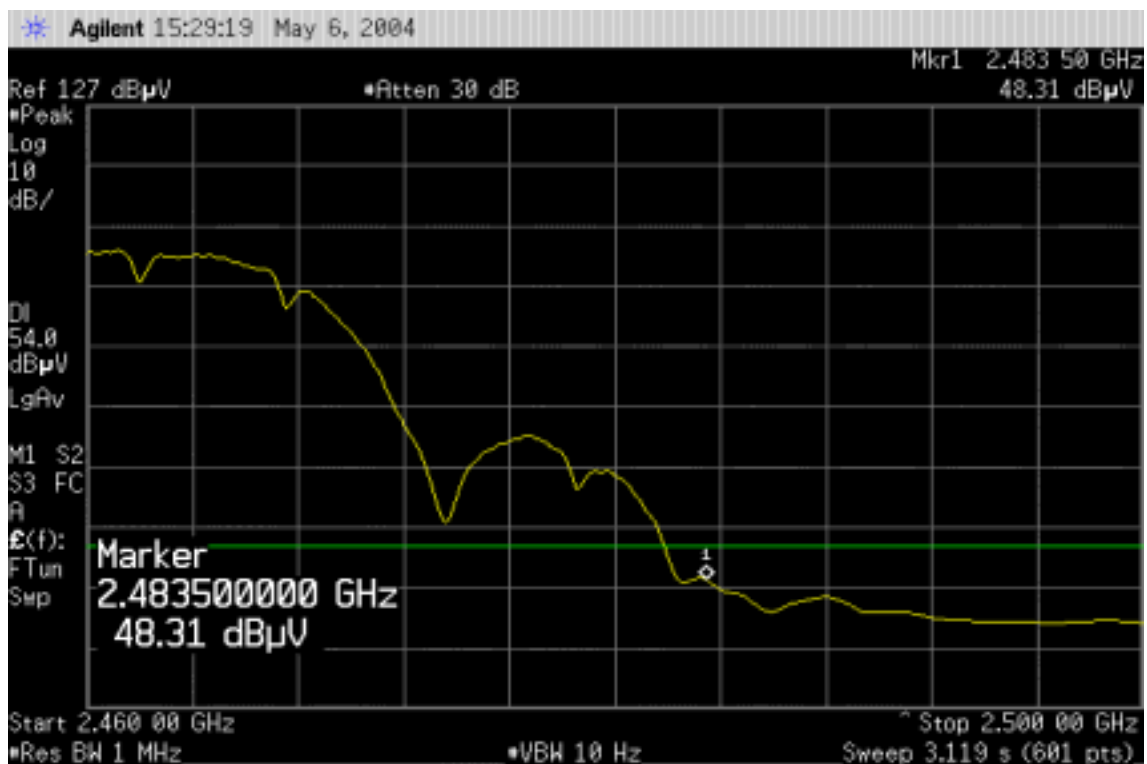



Band Edges (802.11g / CH Low)

Detector mode: Peak

Polarity: Vertical

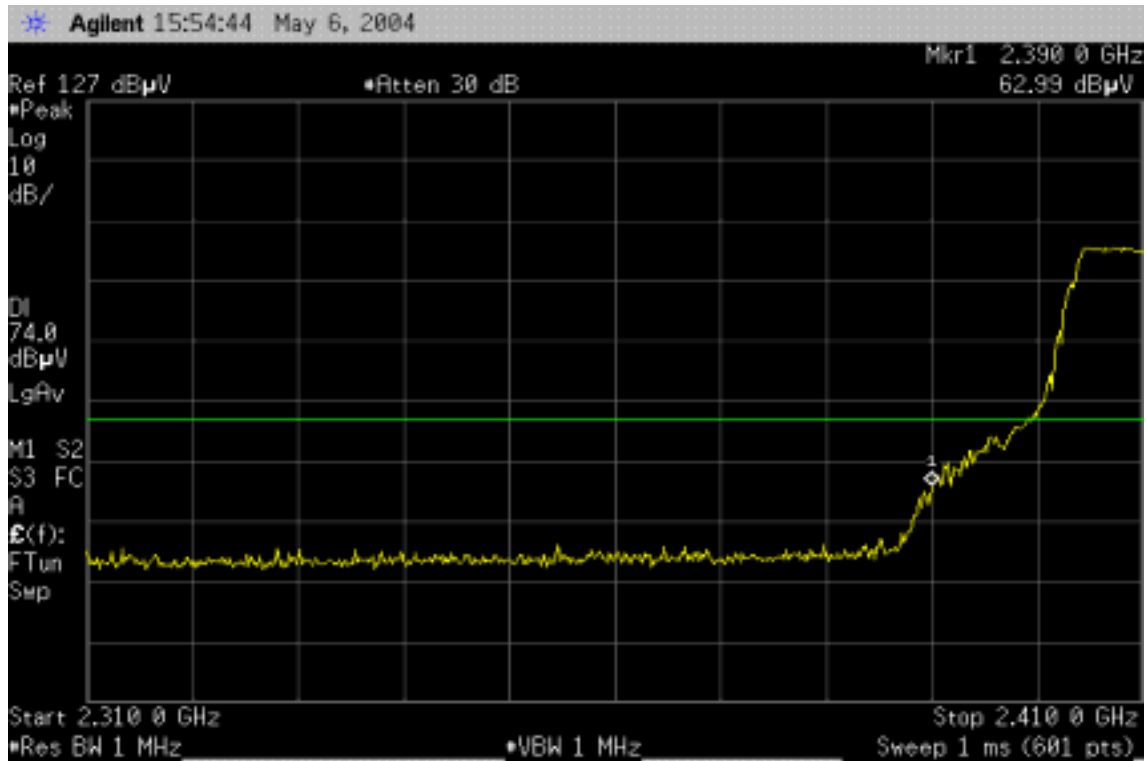

Detector mode: Average

Polarity: Vertical

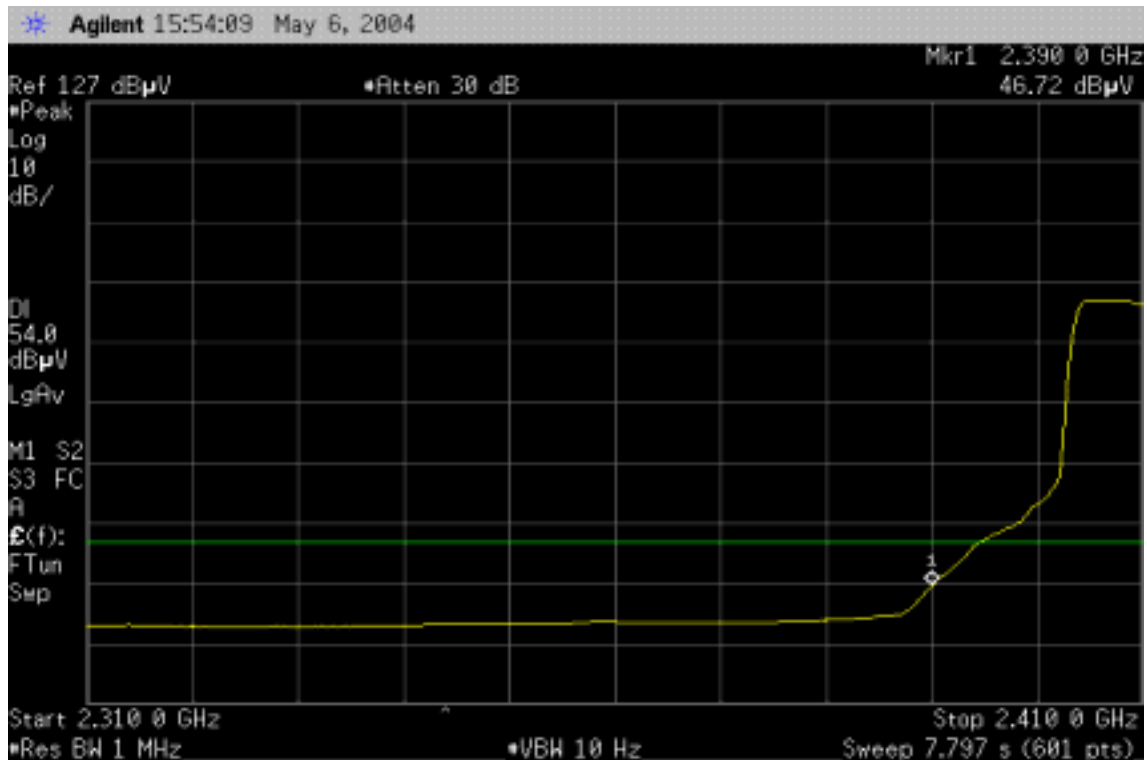



Detector mode: Peak

Polarity: Horizontal

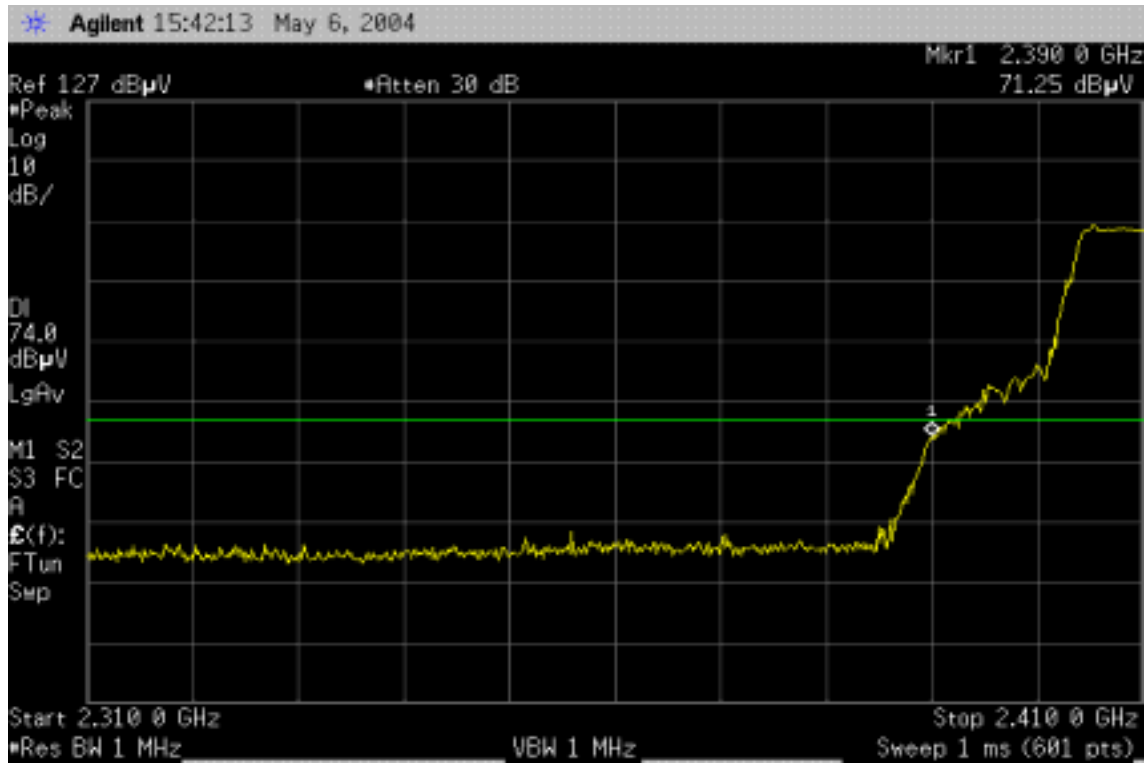

Detector mode: Average

Polarity: Horizontal

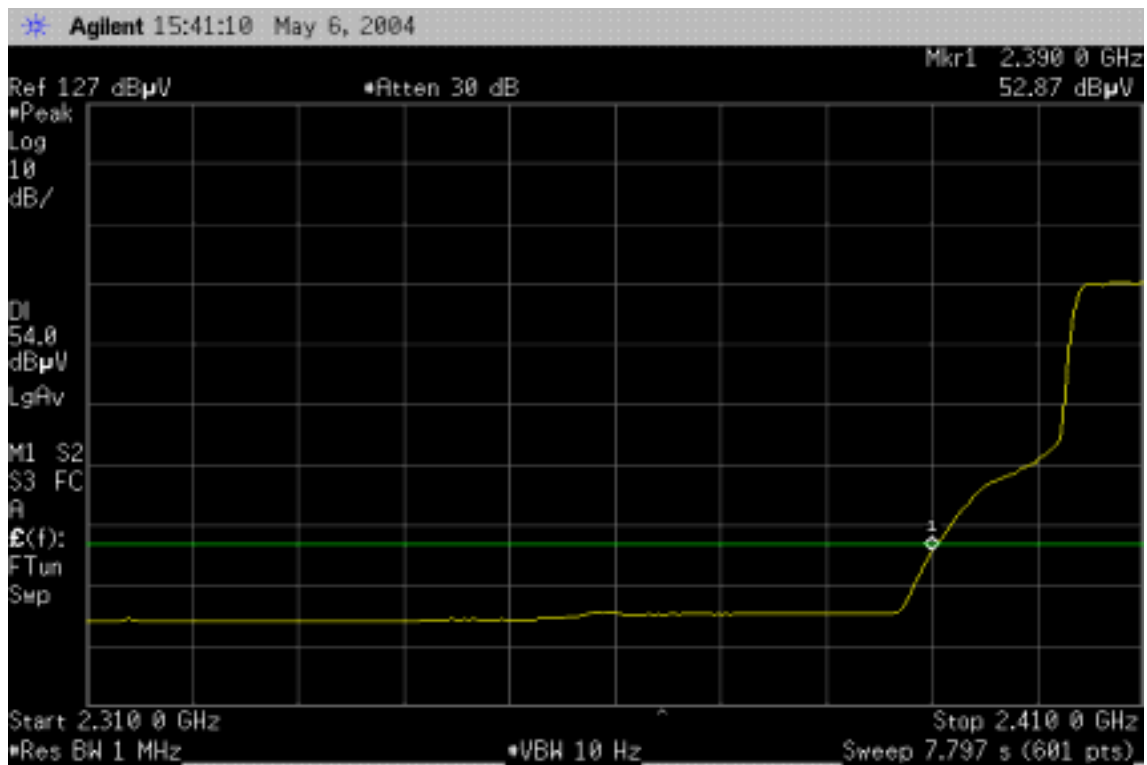



Band Edges (802.11g / CH High)

Detector mode: Peak

Polarity: Vertical

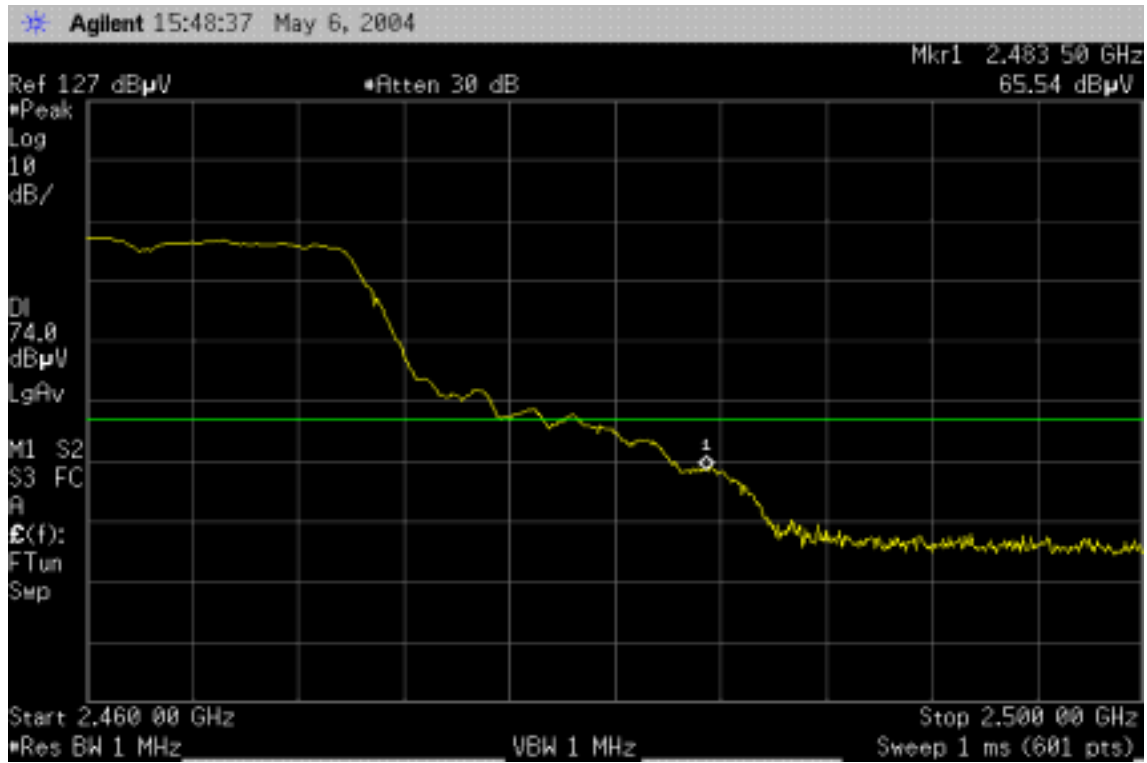

Detector mode: Average

Polarity: Vertical

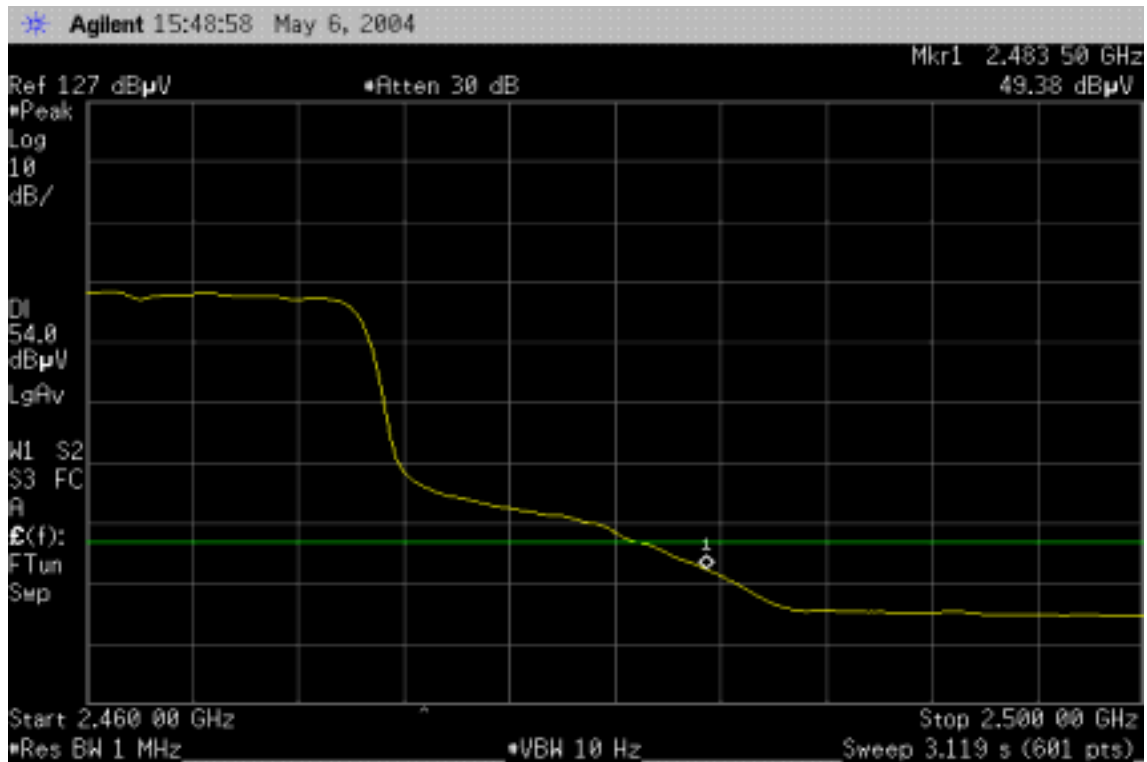



Detector mode: Peak

Polarity: Horizontal

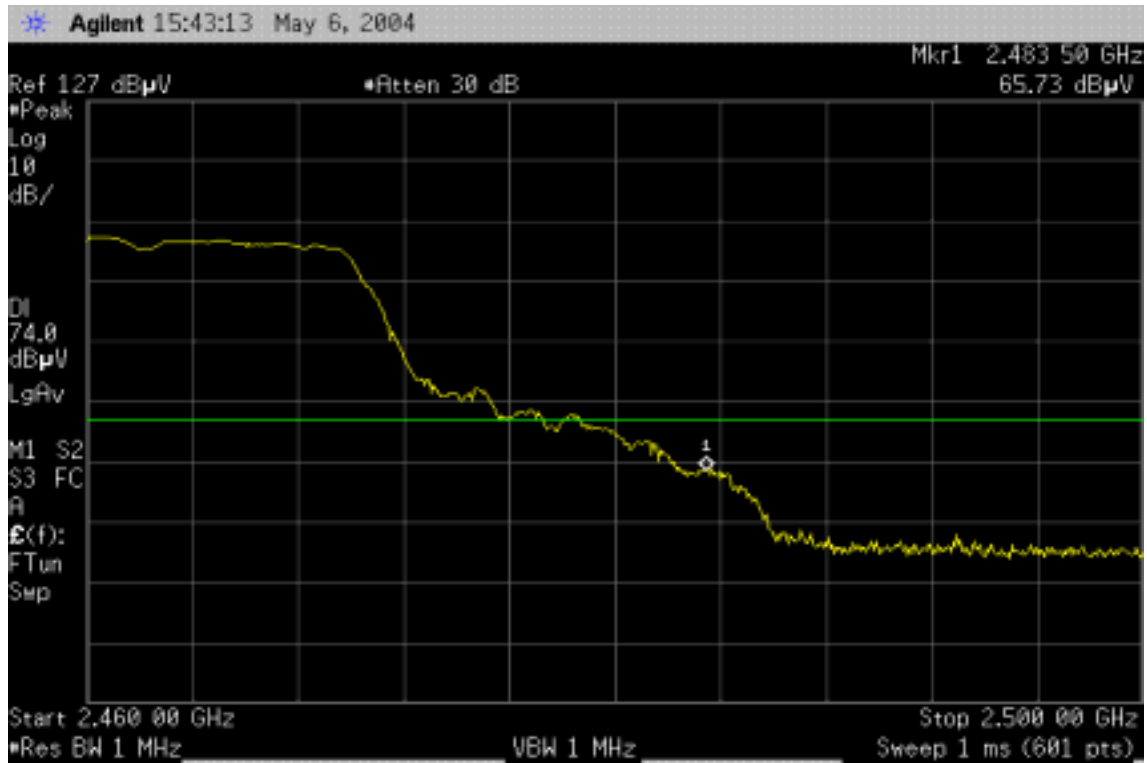

Detector mode: Average

Polarity: Horizontal

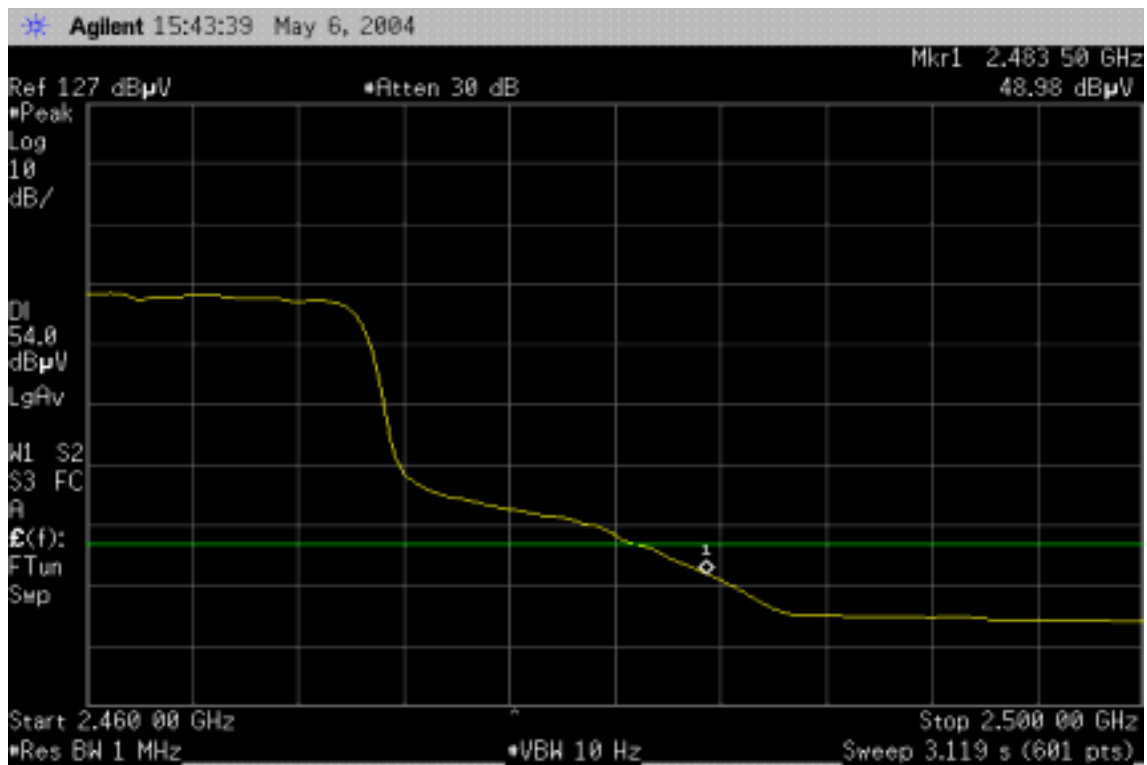

7.4 PEAK POWER SPECTRAL DENSITY

LIMIT

1. For direct sequence systems, the peak power spectral density conducted from the intentional radiator to the antenna shall not be greater than 8dBm in any 3kHz band during any time interval of continuous transmission.
2. The direct sequence operating of the hybrid system, with the frequency hopping operation turned off, shall comply with the power density requirements of paragraph (d) of this section.

MEASUREMENT EQUIPMENT USED

Name of Equipment	Manufacturer	Model	Serial Number	Calibration Due
Spectrum Analyzer	Agilent	E4446A	MY43360131	04/28/2004

Remark: Each piece of equipment is scheduled for calibration once a year.

Test Configuration

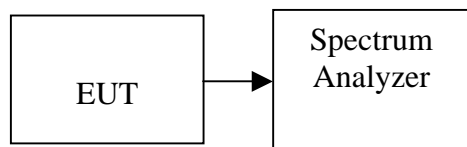

TEST PROCEDURE

1. Place the EUT on the table and set it in transmitting mode.
Remove the antenna from the EUT and then connect a low loss RF cable from the antenna port to the spectrum analyzer.
2. Set the spectrum analyzer as RBW = 3kHz, VBW = 10kHz, Span = 300kHz, Sweep=100s
3. Record the max. reading.
4. Repeat the above procedure until the measurements for all frequencies are completed.



TEST RESULTS

No non-compliance noted

Test Data

Test mode: IEEE 802.11b

Channel	Frequency	Reading (dBm)	Factor (dB)	PPSD (dBm)	Limit (dBm)	Result
Low	2412	-15.86	2.00	-13.86	8.00	PASS
Mid	2437	-15.97	2.00	-13.97		PASS
High	2462	-16.06	2.00	-14.06		PASS

Test mode: IEEE 802.11g

Channel	Frequency	Reading (dBm)	Factor (dB)	PPSD (dBm)	Limit (dBm)	Result
Low	2412	-15.39	2.00	-13.39	8.00	PASS
Mid	2437	-15.49	2.00	-13.49		PASS
High	2462	-15.30	2.00	-13.30		PASS



Test Plot

802.11b mode

PPSD (CH Low)

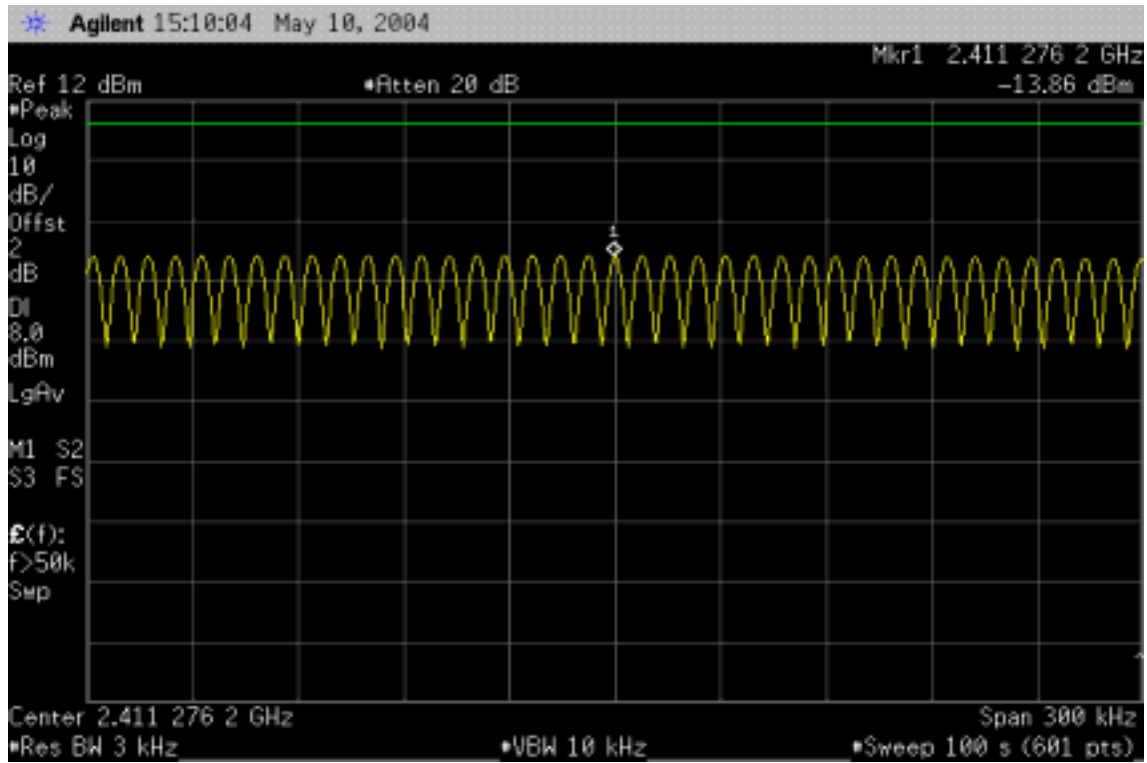

PPSD (CH Mid)

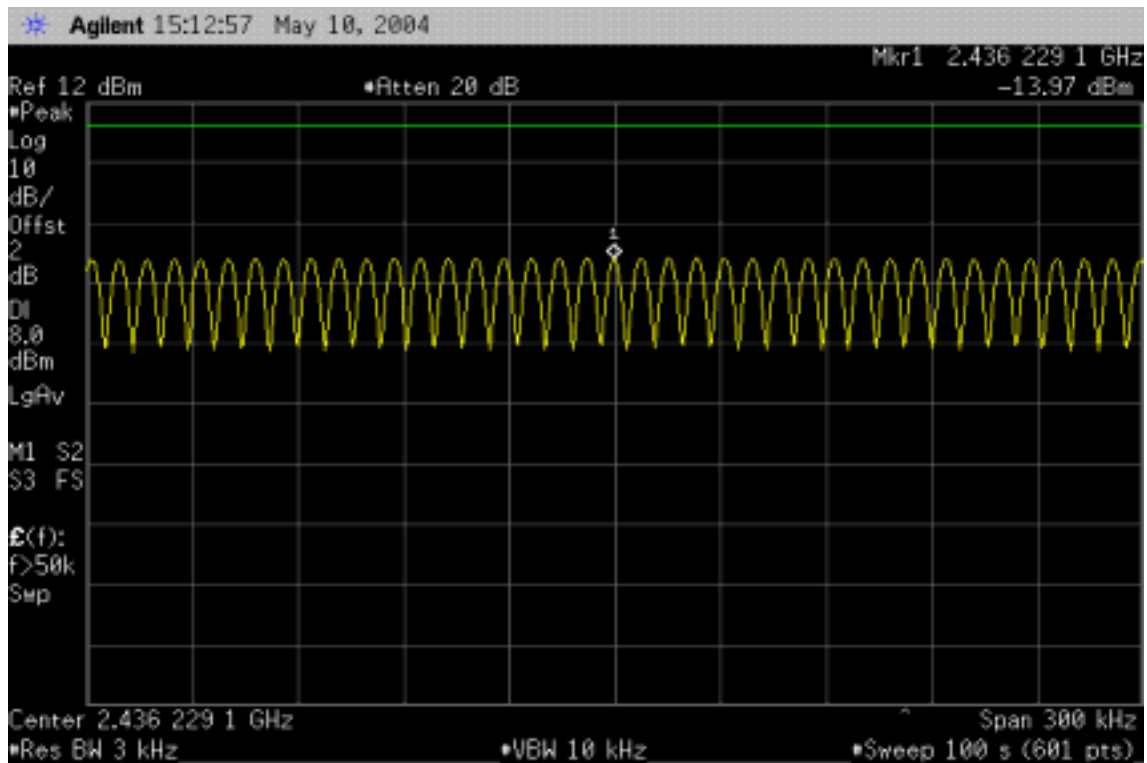

PPSD (CH High)

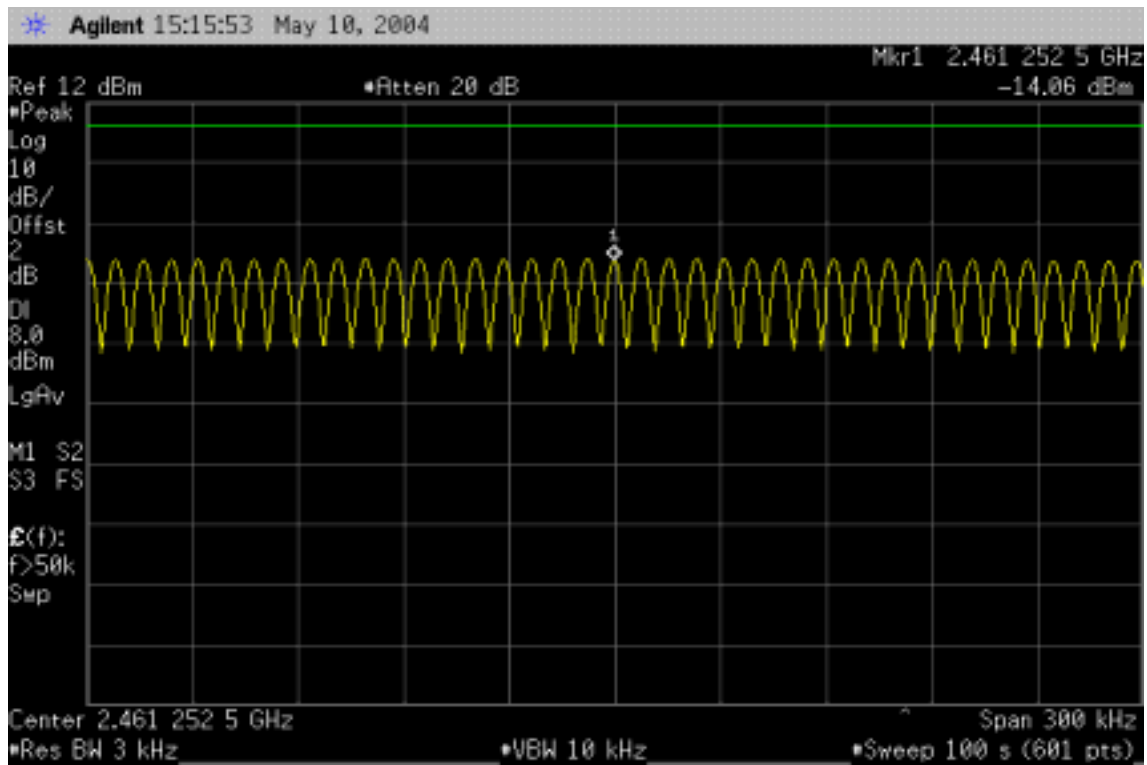

802.11g mode

PPSD (CH Low)

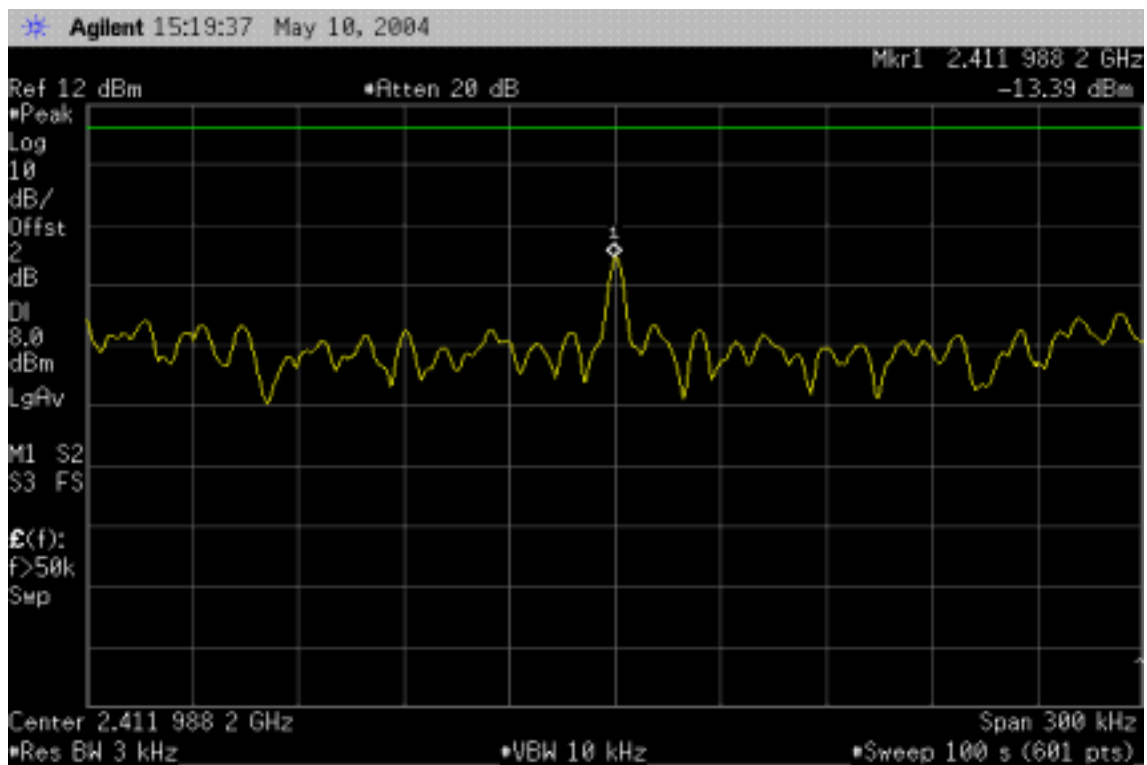



PPSD (CH Mid)

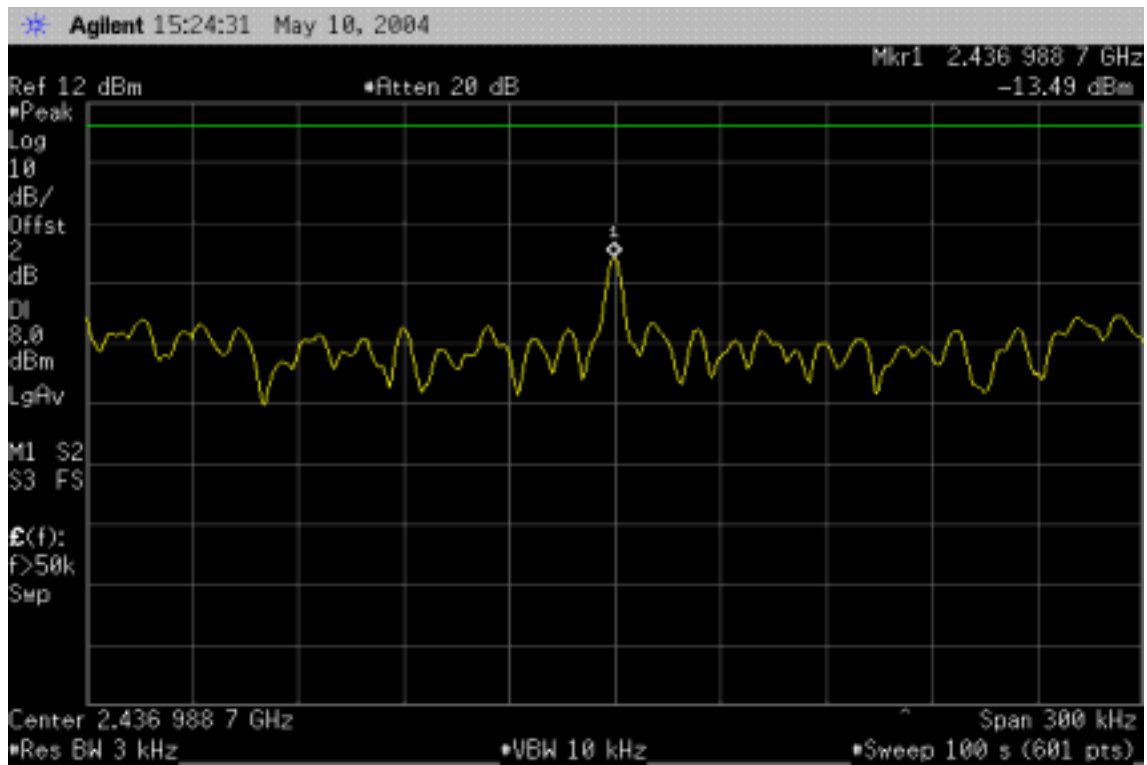

PPSD (CH High)

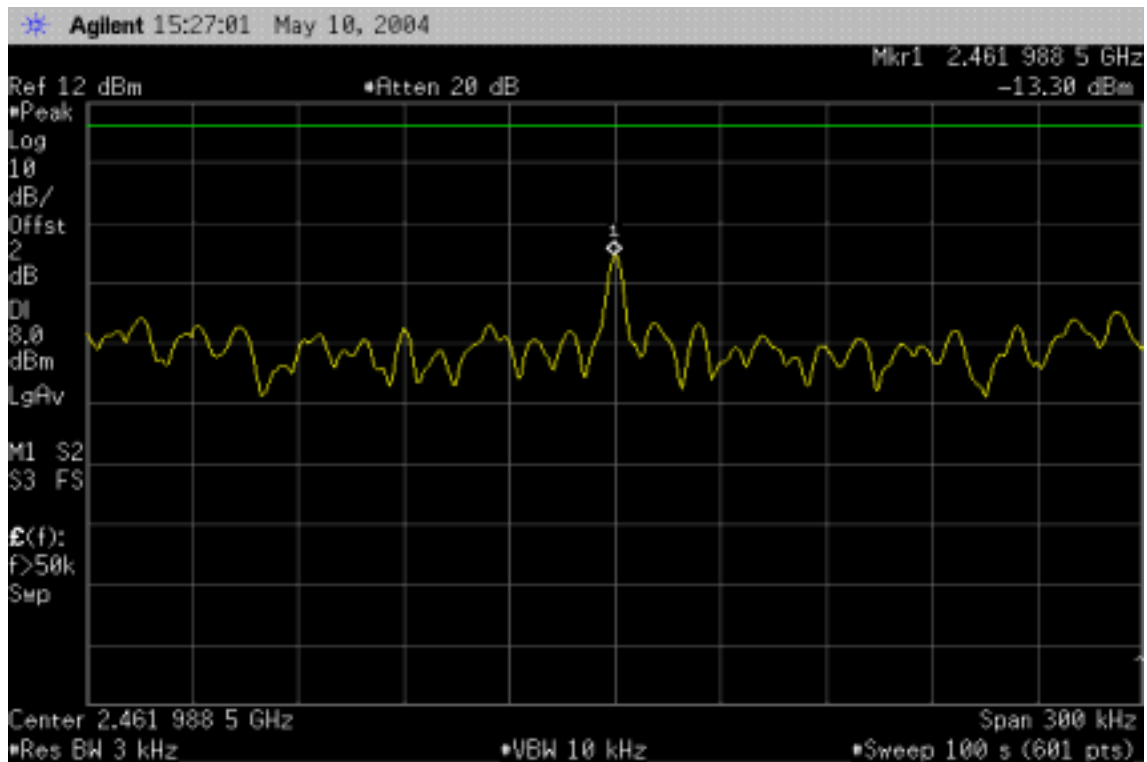



7.5 RADIO FREQUENCY EXPOSURE

LIMIT

Systems operating under the provisions of this section shall be operated in a manner that ensures that the public is not exposed to radio frequency energy levels in excess of the Commission's guidelines. See §15.247(b)(4) and §1.1307(b)(1) of this chapter.

EUT Specification

EUT	Notebook built-in b/g WLAN Module
Frequency band (Operating)	<input checked="" type="checkbox"/> WLAN: 2.412GHz ~ 2.462GHz <input type="checkbox"/> WLAN: 5.18GHz ~ 5.32GHz / 5.50GHz ~ 5.70GHz <input type="checkbox"/> WLAN: 5.745GHz ~ 5825GHz <input type="checkbox"/> Others _____
Device category	<input type="checkbox"/> Portable (<20cm separation) <input checked="" type="checkbox"/> Mobile (>20cm separation) <input type="checkbox"/> Others _____
Exposure classification	<input type="checkbox"/> Occupational/Controlled exposure (S = 5mW/cm ²) <input checked="" type="checkbox"/> General Population/Uncontrolled exposure (S=1mW/cm ²)
Antenna diversity	<input type="checkbox"/> Single antenna <input checked="" type="checkbox"/> Multiple antennas <input type="checkbox"/> Tx diversity <input type="checkbox"/> Rx diversity <input checked="" type="checkbox"/> Tx/Rx diversity
Max. output power	IEEE 802.11b: 18.91 dBm (77.80mW) IEEE 802.11g: 17.61 dBm (57.67mW)
Antenna gain (Max)	0.66 dBi (Numeric gain: 1.164)
Evaluation applied	<input checked="" type="checkbox"/> MPE Evaluation <input type="checkbox"/> SAR Evaluation*

Note:

1. The maximum output power is 18.91dBm (77.80mW) at 2412MHz (with 1.164 numeric antenna gain.)
2. DTS device is not subject to routine RF evaluation; MPE estimate is used to justify the compliance.
3. For mobile or fixed location transmitters, no SAR consideration applied. The minimum separation generally be used is at least 20 cm, even if the calculations indicate that the MPE distance would be lesser.

TEST RESULTS

No non-compliance noted.

Calculation

Given $E = \sqrt{\frac{30 \times P \times G}{d}}$ & $S = \frac{E^2}{3770}$

Where $E =$ Field Strength in Volts / meter

$P =$ Power in Watts

$G =$ Numeric antenna gain

$d =$ Distance in meters

$S =$ Power Density in milliwatts / square centimeter

Combining equations and re-arranging the terms to express the distance as a function of the remaining variables yields:

$$d = \sqrt{\frac{30 \times P \times G}{3770 \times S}}$$

Changing to units of mW and cm, using:

$$P (mW) = P (W) / 1000 \text{ and}$$

$$d (cm) = 100 * d (m)$$

Yields

$$d = 100 \times \sqrt{\frac{30 \times (P / 1000) \times G}{3770 \times S}} = 0.282 \times \sqrt{\frac{P \times G}{S}}$$

Where $d =$ distance in cm

$P =$ Power in mW

$G =$ Numeric antenna gain

$S =$ Power Density in mW / cm²

Substituting the logarithmic form of power and gain using:

$$P (mW) = 10^{(P (dBm) / 10)} \text{ and}$$

$$G (\text{numeric}) = 10^{(G (dBi) / 10)}$$

Yields

$$d = 0.282 \times \frac{10^{(P+G)/20}}{\sqrt{20}}$$

Equation 1

Where $d =$ MPE safe distance in cm

$P =$ Power in dBm

$G =$ Antenna Gain in dBi

$S =$ Power Density Limit in mW / cm²



Maximum Permissible Exposure (Bluetooth Module)

EUT output power = 77.80 mW

Antenna Gain = 1.164

S = 1.0 mW / cm² from 1.1310 Table 1

Substituting these parameters into the above Equation 1:

→ MPE Safe Distance = 2.684 cm

(For mobile or fixed location transmitters, the minimum separation distance is 20 cm, even if calculations indicate that the MPE distance would be less.)

7.6 SPURIOUS EMISSIONS

7.6.1 Conducted Measurement

LIMIT

In any 100 kHz bandwidth outside the frequency band in which the spread spectrum or digitally modulated intentional radiator is operating, the radio frequency power that is produced by the intentional radiator shall be at least 20 dB below that in the 100 kHz bandwidth within the band that contains the highest level of the desired power, based on either an RF conducted or a radiated measurement. Attenuation below the general limits specified in Section 15.209(a) is not required. In addition, radiated emissions which fall in the restricted bands, as defined in Section 15.205(a), must also comply with the radiated emission limits specified in Section 15.209(a) (see Section 15.205(c)).

MEASUREMENT EQUIPMENT USED

Name of Equipment	Manufacturer	Model	Serial Number	Calibration Due
Spectrum Analyzer	Agilent	E4446A	MY43360131	01/10/2005

Remark: Each piece of equipment is scheduled for calibration once a year.

Test Configuration

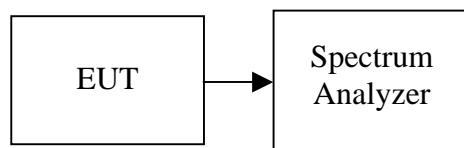

TEST PROCEDURE

Conducted RF measurements of the transmitter output were made to confirm that the EUT antenna port conducted emissions meet the specified limit and to identify any spurious signals that require further investigation or measurements on the radiated emissions site.

The transmitter output is connected to the spectrum analyzer. The resolution bandwidth is set to 100 KHz. The video bandwidth is set to 100 KHz.

Measurements are made over the 30MHz to 26GHz range with the transmitter set to the lowest, middle, and highest channels.

TEST RESULTS

No non-compliance noted

Test Plot

IEEE 802.11b / CH Low

30MHz ~ 2.9GHz

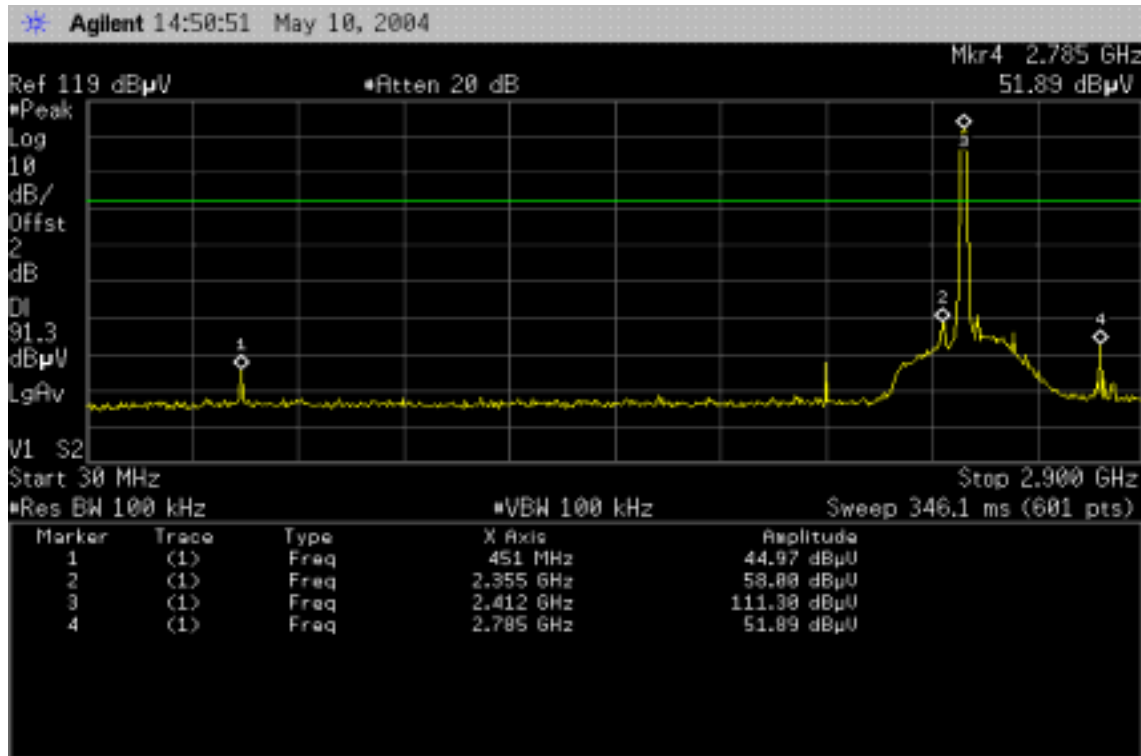

2.9GHz ~ 26.5GHz

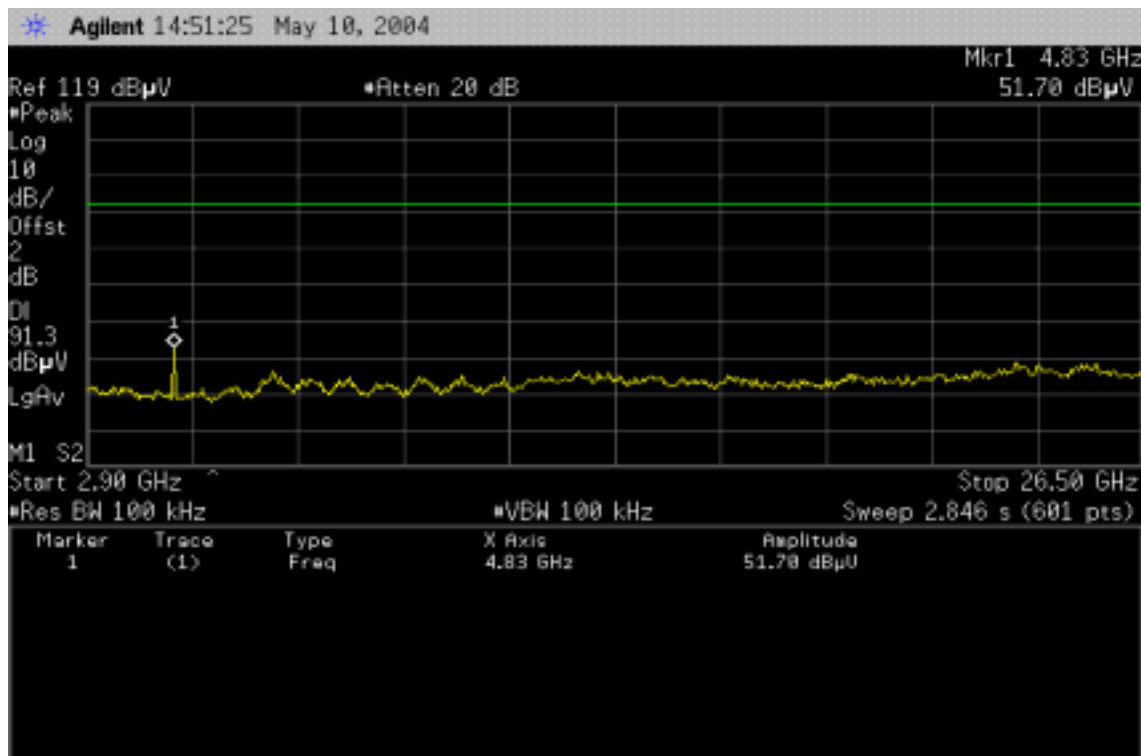



IEEE 802.11b / CH Mid

30MHz ~ 2.9GHz

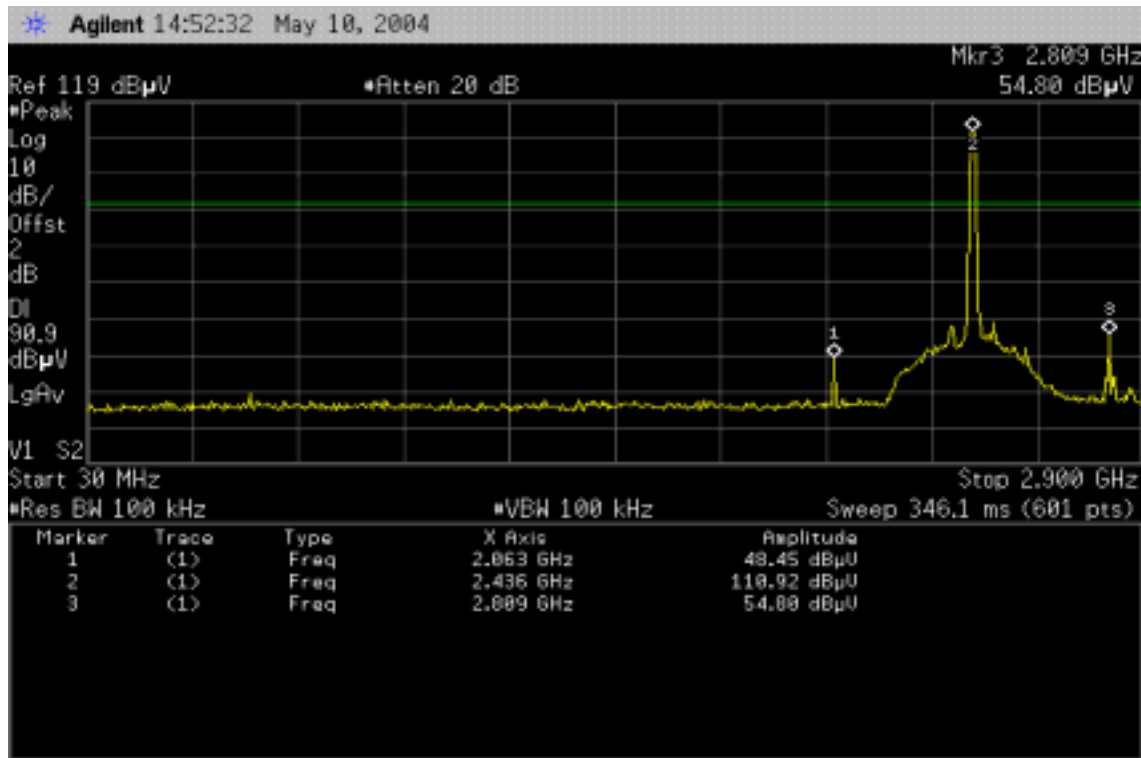

2.9GHz ~ 26.5GHz

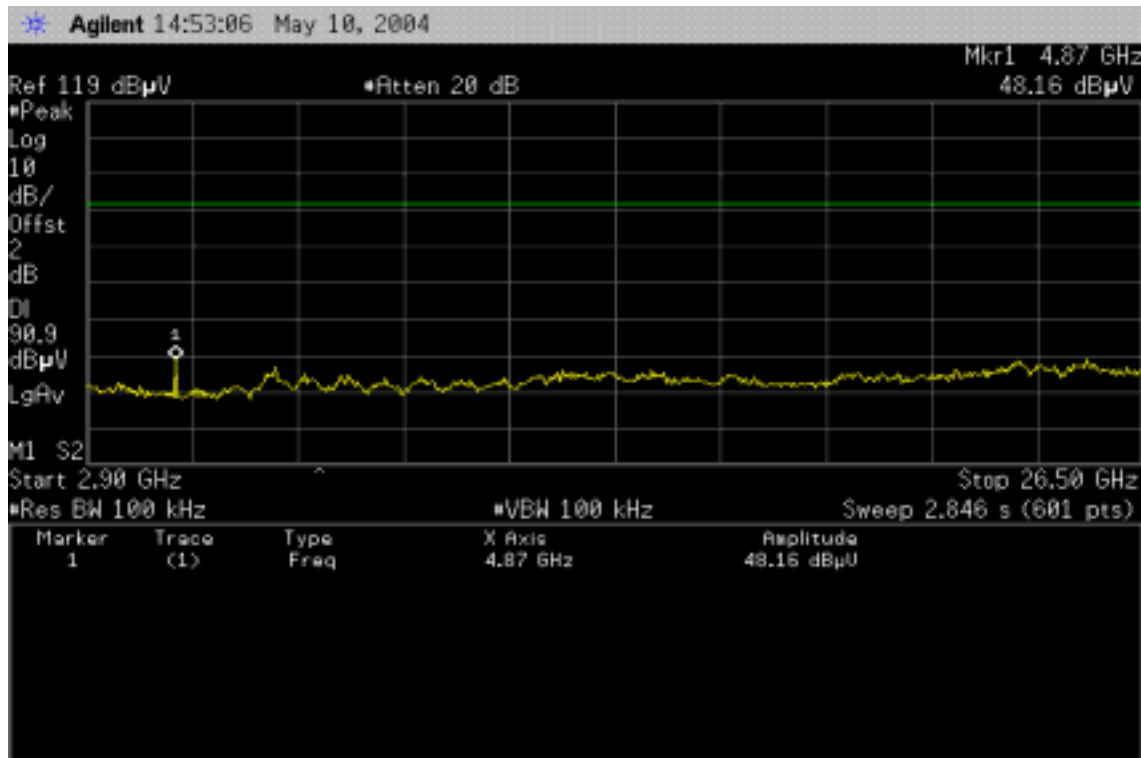



IEEE 802.11b / CH High

30MHz ~ 2.9GHz

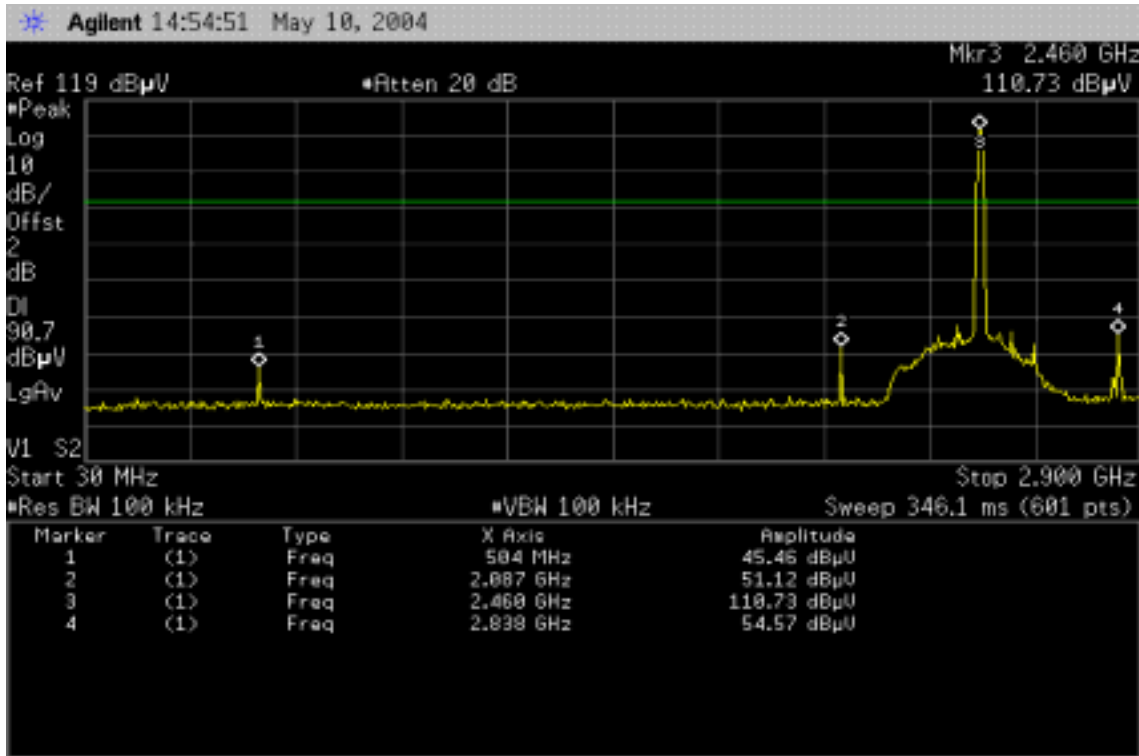

2.9GHz ~ 26.5GHz

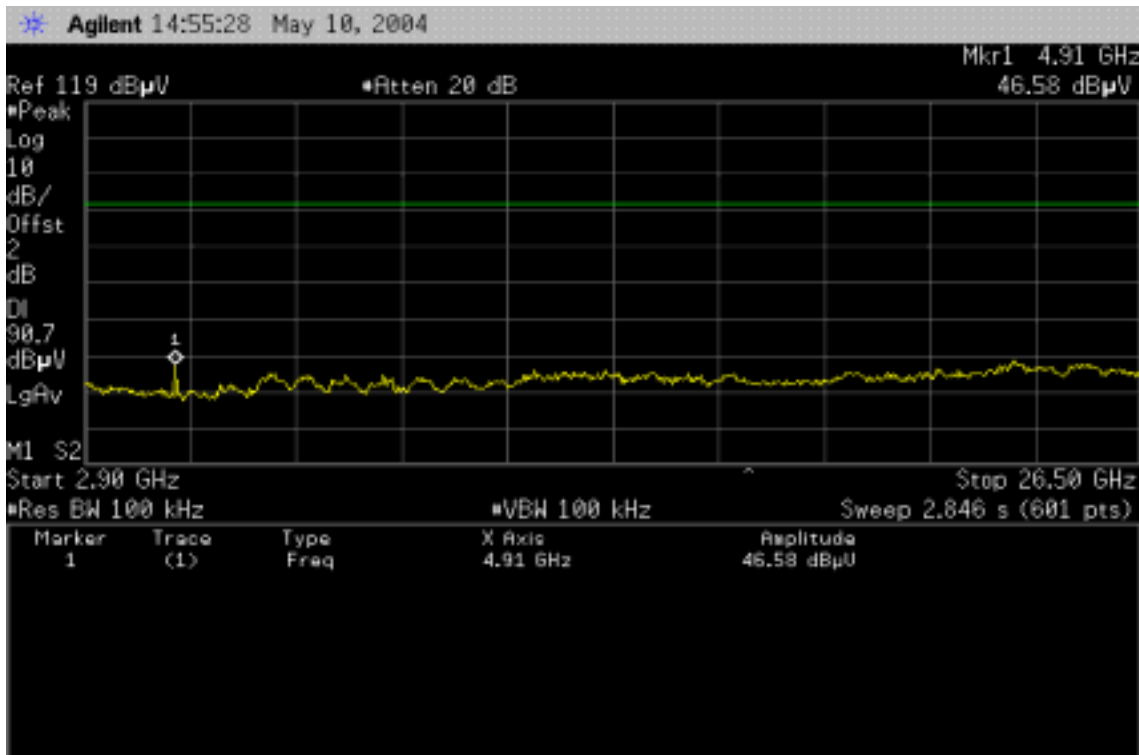



IEEE 802.11g / CH Low

30MHz ~ 2.9GHz

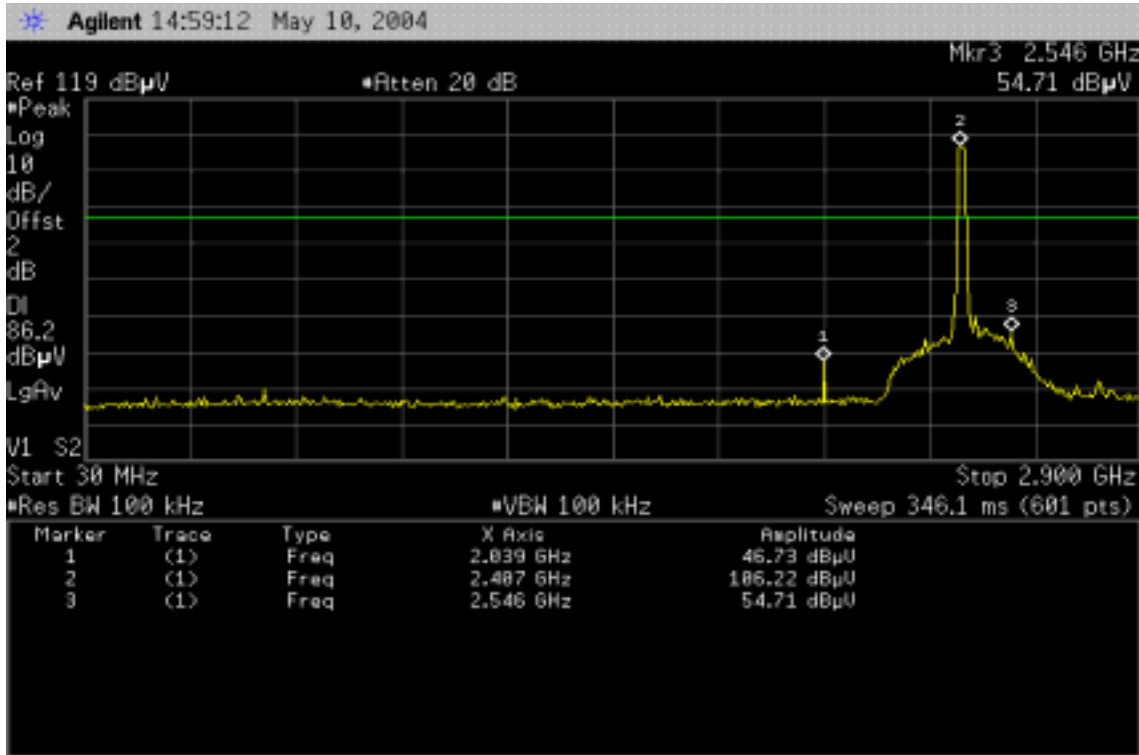

2.9GHz ~ 26.5GHz

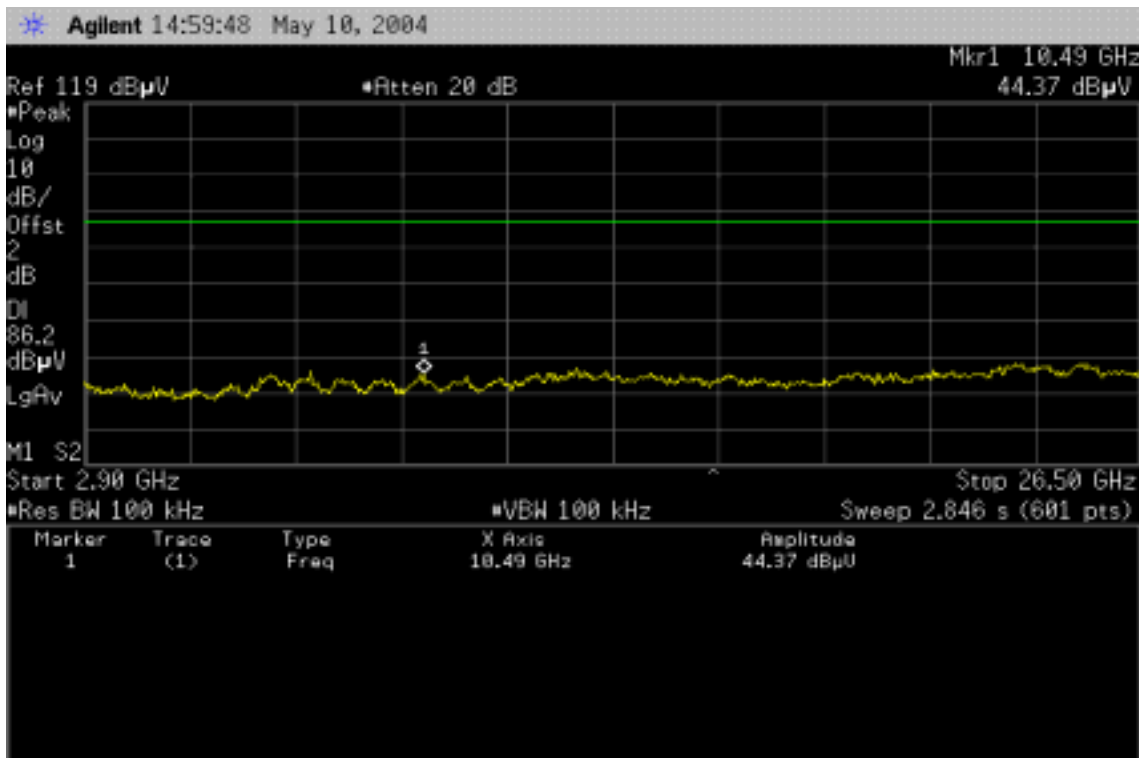

IEEE 802.11g / CH Mid

30MHz ~ 2.9GHz

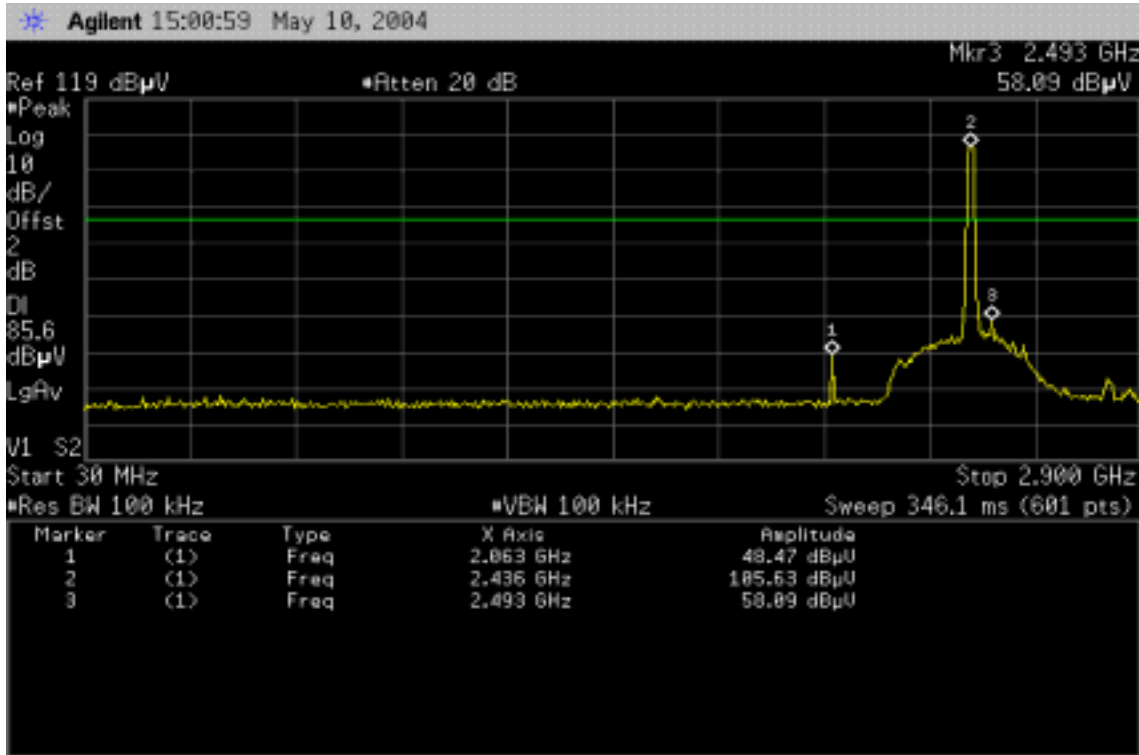

2.9GHz ~ 26.5GHz

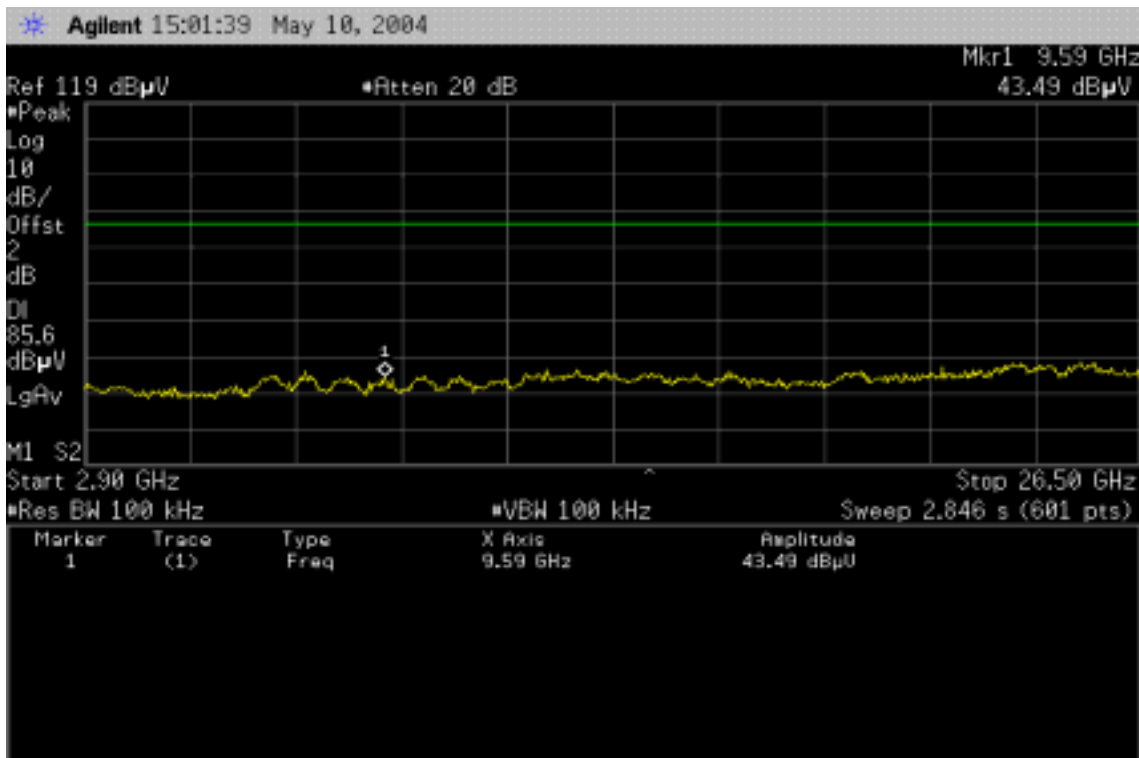



IEEE 802.11g / CH High

30MHz ~ 2.9GHz

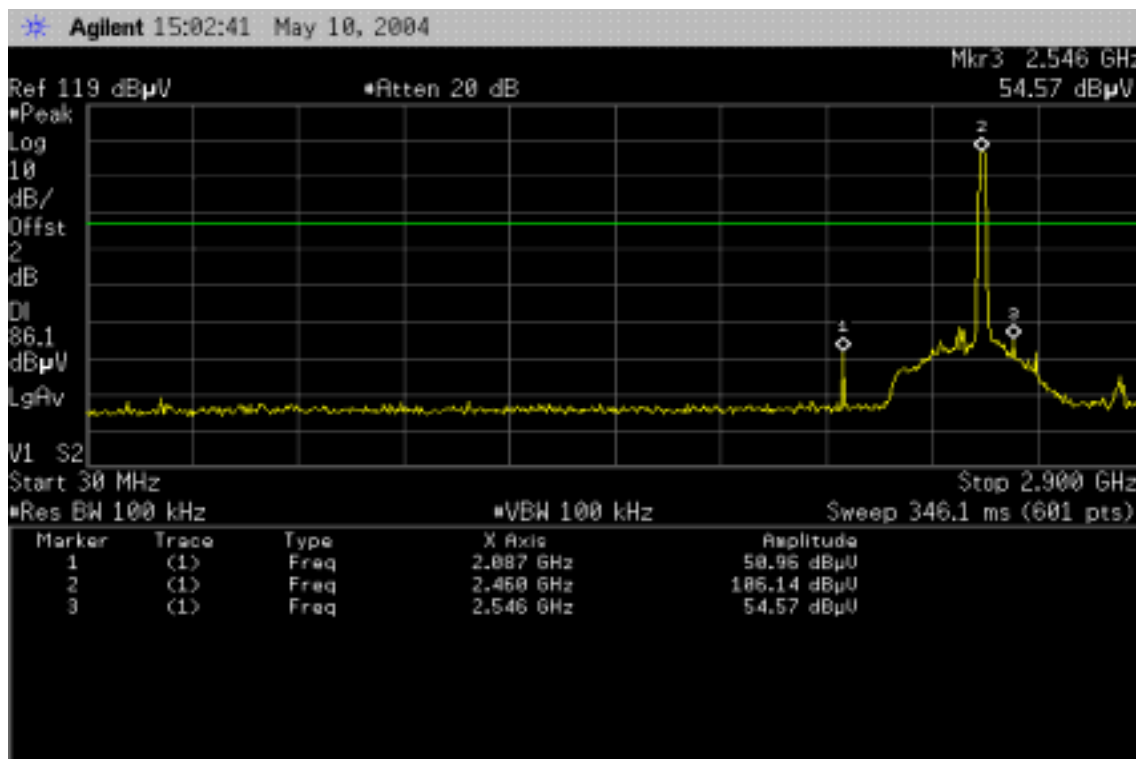

2.9GHz ~ 26.5GHz

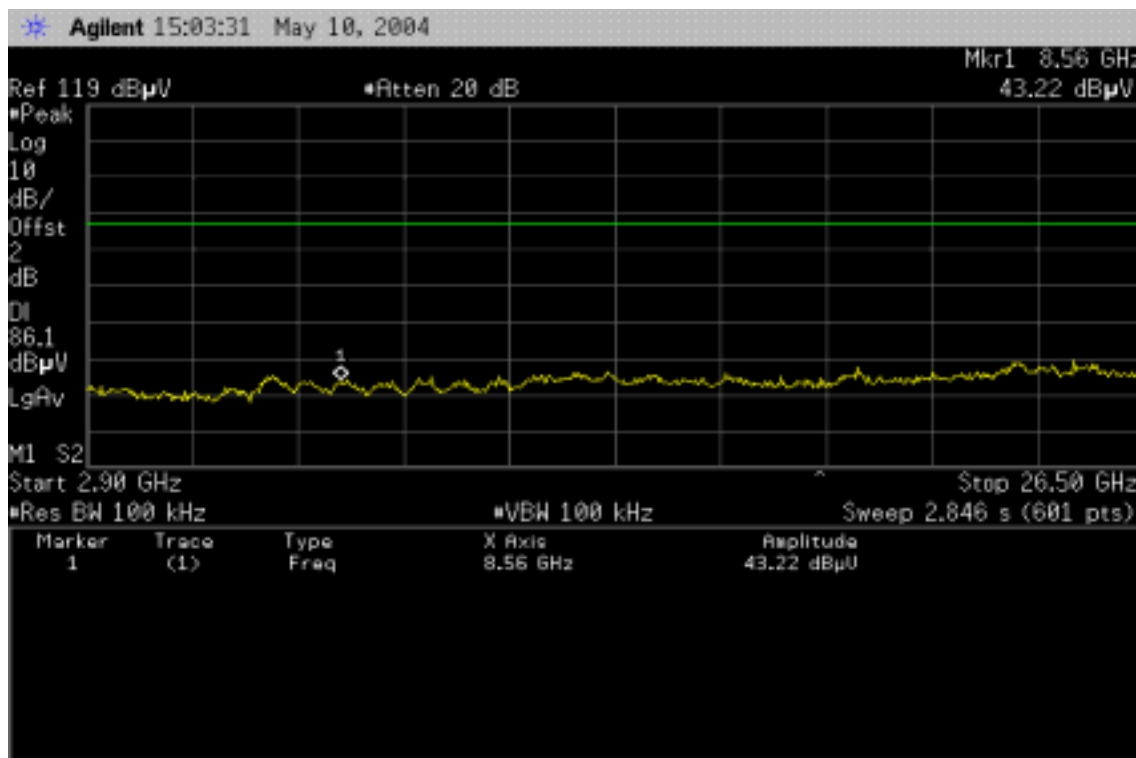



7.6.2 Radiated Emissions

LIMIT

1. Except as provided elsewhere in this Subpart, the emissions from an intentional radiator shall not exceed the field strength levels specified in the following table:

Frequency (MHz)	Field Strength (mV/m)	Measurement Distance (m)
30-88	100*	3
88-216	150*	3
216-960	200*	3
Above 960	500	3

Note: Except as provided in paragraph (g), fundamental emissions from intentional radiators operating under this Section shall not be located in the frequency bands 54-72 MHz, 76-88 MHz, 174-216 MHz or 470-806 MHz. However, operation within these frequency bands is permitted under other sections of this Part, e.g., Sections 15.231 and 15.241.

2. In the above emission table, the tighter limit applies at the band edges.

Frequency (Hz)	Field Strength (μ V/m at 3-meter)	Field Strength (dB μ V/m at 3-meter)
30-88	100	40
88-216	150	43.5
216-960	200	46
Above 960	500	54

MEASUREMENT EQUIPMENT USED

Open Area Test Site # 3				
Name of Equipment	Manufacturer	Model	Serial Number	Calibration Due
Spectrum Analyzer	ADVANTEST	R3261A	N/A	03/18/2005
EMI Test Receiver	R&S	ESVS20	838804/004	01/04/2005
Pre-Amplifier	HP	8447D	2944A09173	03/03/2005
Bi-log Antenna	SCHWAZBECK	VULB9163	145	07/05/2004
Turn Table	EMCO	2081-1.21	9709-1885	N.C.R
Antenna Tower	EMCO	2075-2	9707-2060	N.C.R
Controller	EMCO	2090	9709-1256	N.C.R
RF Switch	ANRITSU	MP59B	M53867	N.C.R
Site NSA	C&C	N/A	N/A	09/06/2004
Horn antenna	Schwarzbeck	BBHA 9120	D210	02/23/2005
Loop Antenna	EMCO	6502	2356	07/10/2004
Pre-Amplifier	HP	8449B	3008B00965	10/02/2004

Remark: Each piece of equipment is scheduled for calibration once a year.

Test Configuration

Below 1 GHz

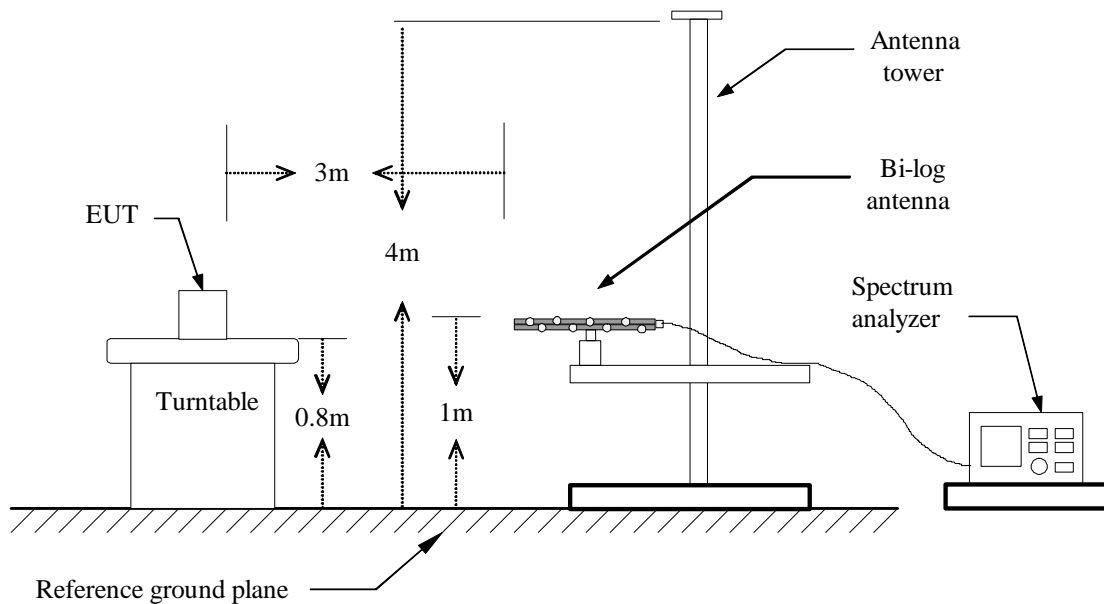

Above 1 GHz

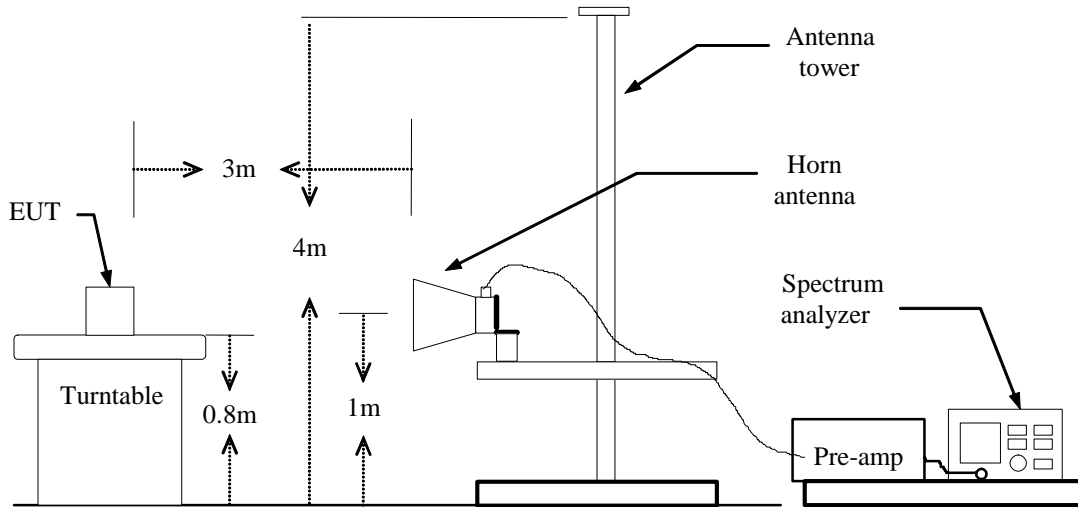

TEST PROCEDURE

1. The EUT is placed on a turntable, which is 0.8m above ground plane.
2. The turntable shall be rotated for 360 degrees to determine the position of maximum emission level.
3. EUT is set 3m away from the receiving antenna, which is varied from 1m to 4m to find out the highest emissions.
4. Maximum procedure was performed on the six highest emissions to ensure EUT compliance.
5. And also, each emission was to be maximized by changing the polarization of receiving antenna both horizontal and vertical.
6. Repeat above procedures until the measurements for all frequencies are complete.

**TEST RESULTS****Below 1 GHz****Operation Mode:** TX / IEEE 802.11b / CH Low**Test Date:** May 10, 2004**Temperature:** 20°C**Tested by:** Max Yao**Humidity:** 70 % RH**Polarity:** Ver. / Hor.

Freq. (MHz)	Ant.Pol. H/V	Detector Mode (PK/QP)	Reading (dBuV)	Factor (dB)	Actual FS (dBuV/m)	Limit 3m (dBuV/m)	Safe Margin (dB)
260.40	V	Peak	20.51	16.06	36.57	46.00	-9.43
324.50	V	Peak	18.62	17.34	35.96	46.00	-10.04
336.17	V	Peak	19.94	17.66	37.60	46.00	-8.40
455.17	V	Peak	15.79	20.41	36.20	46.00	-9.80
519.33	V	Peak	13.08	23.19	36.27	46.00	-9.73
584.67	V	Peak	12.86	25.04	37.90	46.00	-8.10
142.50	H	Peak	18.84	10.93	29.77	43.50	-13.73
240.15	H	Peak	16.38	15.92	32.30	46.00	-13.70
259.95	H	Peak	20.33	16.07	36.40	46.00	-9.60
336.17	H	Peak	18.77	17.66	36.43	46.00	-9.57
455.17	H	Peak	13.62	20.41	34.03	46.00	-11.97
519.33	H	Peak	9.24	23.19	32.43	46.00	-13.57

Notes:

1. Measuring frequencies from 30 MHz to the 1GHz.
2. Radiated emissions measured in frequency range from 30 MHz to 1000MHz were made with an instrument using Peak detector mode.
3. Data of measurement within this frequency range shown " --- " in the table above means the reading of emissions are attenuated more than 20dB below the permissible limits or the field strength is too small to be measured.
4. The IF bandwidth of SPA between 30MHz to 1GHz was 100kHz.



Operation Mode: TX / IEEE 802.11b / CH Mid

Test Date: May 10, 2004

Temperature: 20°C

Tested by: Max Yao

Humidity: 70 % RH

Polarity: Ver. / Hor.

Freq. (MHz)	Ant.Pol. H/V	Detector Mode (PK/QP)	Reading (dBuV)	Factor (dB)	Actual FS (dBuV/m)	Limit 3m (dBuV/m)	Safe Margin (dB)
259.95	V	Peak	21.33	16.07	37.40	46.00	-8.60
324.50	V	Peak	18.29	17.34	35.63	46.00	-10.37
336.17	V	Peak	20.11	17.66	37.77	46.00	-8.23
455.17	V	Peak	15.45	20.41	35.86	46.00	-10.14
520.50	V	Peak	13.05	23.24	36.29	46.00	-9.71
585.83	V	Peak	11.87	25.06	36.93	46.00	-9.07
142.05	H	Peak	18.73	10.92	29.65	43.50	-13.85
260.40	H	Peak	20.34	16.06	36.40	46.00	-9.60
330.33	H	Peak	15.28	17.50	32.78	46.00	-13.22
336.17	H	Peak	18.44	17.66	36.10	46.00	-9.90
455.17	H	Peak	13.62	20.41	34.03	46.00	-11.97
650.00	H	Peak	9.54	24.88	34.42	46.00	-11.58

Notes:

1. Measuring frequencies from 30 MHz to the 1GHz.
2. Radiated emissions measured in frequency range from 30 MHz to 1000MHz were made with an instrument using Peak detector mode.
3. Data of measurement within this frequency range shown " --- " in the table above means the reading of emissions are attenuated more than 20dB below the permissible limits or the field strength is too small to be measured.
4. The IF bandwidth of SPA between 30MHz to 1GHz was 100kHz.



Operation Mode: TX / IEEE 802.11b / CH High

Test Date: May 10, 2004

Temperature: 20°C

Tested by: Max Yao

Humidity: 70 % RH

Polarity: Ver. / Hor.

Freq. (MHz)	Ant.Pol. H/V	Detector Mode (PK/QP)	Reading (dBuV)	Factor (dB)	Actual FS (dBuV/m)	Limit 3m (dBuV/m)	Safe Margin (dB)
260.40	V	Peak	22.01	16.40	38.41	46.00	-7.59
330.33	V	Peak	18.95	17.50	36.45	46.00	-9.55
336.17	V	Peak	20.77	17.66	38.43	46.00	-7.57
455.17	V	Peak	16.95	20.41	37.36	46.00	-8.64
520.50	V	Peak	12.88	23.24	36.12	46.00	-9.88
584.67	V	Peak	12.19	25.04	37.23	46.00	-8.77
240.15	H	Peak	17.38	15.92	33.30	46.00	-12.70
260.40	H	Peak	19.84	16.06	35.90	46.00	-10.10
325.67	H	Peak	14.61	17.37	31.98	46.00	-14.02
336.17	H	Peak	19.44	17.66	37.10	46.00	-8.90
455.17	H	Peak	13.79	20.41	34.20	46.00	-11.80
520.50	H	Peak	8.88	23.24	32.12	46.00	-13.88

Notes:

1. Measuring frequencies from 30 MHz to the 1GHz.
2. Radiated emissions measured in frequency range from 30 MHz to 1000MHz were made with an instrument using Peak detector mode.
3. Data of measurement within this frequency range shown " --- " in the table above means the reading of emissions are attenuated more than 20dB below the permissible limits or the field strength is too small to be measured.
4. The IF bandwidth of SPA between 30MHz to 1GHz was 100kHz.



Operation Mode: TX / IEEE 802.11g / CH Low

Test Date: May 10, 2004

Temperature: 20°C

Tested by: Max Yao

Humidity: 70 % RH

Polarity: Ver. / Hor.

Freq. (MHz)	Ant.Pol. H/V	Detector Mode (PK/QP)	Reading (dBuV)	Factor (dB)	Actual FS (dBuV/m)	Limit 3m (dBuV/m)	Safe Margin (dB)
259.95	V	Peak	21.16	16.07	37.23	46.00	-8.77
325.67	V	Peak	19.78	17.37	37.15	46.00	-8.85
336.17	V	Peak	20.44	17.66	38.10	46.00	-7.90
520.50	V	Peak	14.21	23.24	37.45	46.00	-8.55
585.83	V	Peak	13.37	25.06	38.43	46.00	-7.57
650.00	V	Peak	12.04	24.88	36.92	46.00	-9.08
260.40	H	Peak	19.17	16.06	35.23	46.00	-10.77
330.33	H	Peak	15.45	17.50	32.95	46.00	-13.05
336.17	H	Peak	18.94	17.66	36.60	46.00	-9.40
357.17	H	Peak	13.65	18.45	32.10	46.00	-13.90
455.17	H	Peak	14.45	20.41	34.86	46.00	-11.14
650.00	H	Peak	8.37	24.88	33.25	46.00	-12.75

Notes:

1. Measuring frequencies from 30 MHz to the 1GHz.
2. Radiated emissions measured in frequency range from 30 MHz to 1000MHz were made with an instrument using Peak detector mode.
3. Data of measurement within this frequency range shown " --- " in the table above means the reading of emissions are attenuated more than 20dB below the permissible limits or the field strength is too small to be measured.
4. The IF bandwidth of SPA between 30MHz to 1GHz was 100kHz.



Operation Mode: TX / IEEE 802.11g / CH Mid

Test Date: May 10, 2004

Temperature: 20°C

Tested by: Max Yao

Humidity: 70 % RH

Polarity: Ver. / Hor.

Freq. (MHz)	Ant.Pol. H/V	Detector Mode (PK/QP)	Reading (dBuV)	Factor (dB)	Actual FS (dBuV/m)	Limit 3m (dBuV/m)	Safe Margin (dB)
260.40	V	Peak	21.34	16.06	37.40	46.00	-8.60
325.67	V	Peak	19.11	17.37	36.48	46.00	-9.52
336.17	V	Peak	20.27	17.66	37.93	46.00	-8.07
455.17	V	Peak	16.95	20.41	37.36	46.00	-8.64
519.33	V	Peak	11.91	23.19	35.10	46.00	-10.90
584.67	V	Peak	11.86	25.04	36.90	46.00	-9.10
240.15	H	Peak	16.71	15.92	32.63	46.00	-13.37
260.40	H	Peak	19.67	16.06	35.73	46.00	-10.27
332.67	H	Peak	15.67	17.56	33.23	46.00	-12.77
336.17	H	Peak	18.94	17.66	36.60	46.00	-9.40
455.17	H	Peak	13.45	20.41	33.86	46.00	-12.14
591.67	H	Peak	6.92	25.19	32.11	46.00	-13.89

Notes:

1. Measuring frequencies from 30 MHz to the 1GHz.
2. Radiated emissions measured in frequency range from 30 MHz to 1000MHz were made with an instrument using Peak detector mode.
3. Data of measurement within this frequency range shown " --- " in the table above means the reading of emissions are attenuated more than 20dB below the permissible limits or the field strength is too small to be measured.
4. The IF bandwidth of SPA between 30MHz to 1GHz was 100kHz.



Operation Mode: TX / IEEE 802.11g / CH High

Test Date: May 10, 2004

Temperature: 20°C

Tested by: Max Yao

Humidity: 70 % RH

Polarity: Ver. / Hor.

Freq. (MHz)	Ant.Pol. H/V	Detector Mode (PK/QP)	Reading (dBuV)	Factor (dB)	Actual FS (dBuV/m)	Limit 3m (dBuV/m)	Safe Margin (dB)
260.40	V	Peak	21.67	16.06	37.73	46.00	-8.27
325.67	V	Peak	18.78	17.37	36.15	46.00	-9.85
336.17	V	Peak	20.61	17.66	38.27	46.00	-7.73
455.17	V	Peak	15.95	20.41	36.36	46.00	-9.64
584.67	V	Peak	11.86	25.04	36.90	46.00	-9.10
650.00	V	Peak	11.04	24.88	35.92	46.00	-10.08
240.15	H	Peak	17.05	15.92	32.97	46.00	-13.03
260.40	H	Peak	19.84	16.06	35.90	46.00	-10.10
330.33	H	Peak	15.45	17.50	32.95	46.00	-13.05
336.17	H	Peak	19.11	17.66	36.77	46.00	-9.23
455.17	H	Peak	13.29	20.41	33.70	46.00	-12.30
584.67	H	Peak	7.52	25.04	32.56	46.00	-13.44

Notes:

1. Measuring frequencies from 30 MHz to the 1GHz.
2. Radiated emissions measured in frequency range from 30 MHz to 1000MHz were made with an instrument using Peak detector mode.
3. Data of measurement within this frequency range shown " --- " in the table above means the reading of emissions are attenuated more than 20dB below the permissible limits or the field strength is too small to be measured.
4. The IF bandwidth of SPA between 30MHz to 1GHz was 100kHz.



Above 1 GHz

Operation Mode: TX / IEEE 802.11b / CH Low

Test Date: May 10, 2004

Temperature: 20°C

Tested by: Max Yao

Humidity: 70 % RH

Polarity: Ver. / Hor.

Freq. (MHz)	Ant. Pol H/V	Peak Reading (dBuV)	AV Reading (dBuV)	Ant. / CL CF (dB)	Actual Fs		Peak Limit (dBuV/m)	AV Limit (dBuV/m)	Margin (dB)	Remark
					Peak (dBuV/m)	AV (dBuV/m)				
1390.00	V	54.34	---	-8.30	46.04	---	74.00	54.00	-7.96	Peak
4158.33	V	41.34	---	2.64	43.98	---	74.00	54.00	-10.02	Peak
N/A										
N/A										
N/A										
N/A										
1396.67	H	50.17	---	-8.27	41.90	---	74.00	54.00	-12.10	Peak
4950.00	H	40.84	---	3.56	44.40	---	74.00	54.00	-9.60	Peak
N/A										
N/A										
N/A										
N/A										

Notes:

1. Measuring frequencies from 1 GHz to the 10th harmonic of highest fundamental frequency.
2. Measurements above show only up to 6 maximum emissions noted, or would be lesser if no specific emissions from the EUT are recorded (ie: margin > 20dB from the applicable limit) and considered that's already beyond the background noise floor.
3. Radiated emissions measured in frequency above 1000MHz were made with an instrument using Peak detector mode and average detector mode of the emission shown in Actual FS column.
4. Spectrum setting:
 - a. Peak Setting 1GHz - 26GHz, RBW = 1MHz, VBW = 1MHz, Sweep time = 200 ms.
 - b. AV Setting 1GHz - 26GHz, RBW = 1MHz, VBW = 10Hz, Sweep time = 200 ms.



Operation Mode: TX / IEEE 802.11b / CH Mid

Test Date: May 10, 2004

Temperature: 20°C

Tested by: Max Yao

Humidity: 70 % RH

Polarity: Ver. / Hor.

Freq. (MHz)	Ant. Pol H/V	Peak Reading (dBuV)	AV Reading (dBuV)	Ant. / CL CF (dB)	Actual Fs		Peak Limit (dBuV/m)	AV Limit (dBuV/m)	Margin (dB)	Remark
					Peak (dBuV/m)	AV (dBuV/m)				
1396.67	V	55.17	---	-8.27	46.90	---	74.00	54.00	-7.10	Peak
N/A										
N/A										
N/A										
N/A										
N/A										
1393.33	H	49.84	---	-8.29	41.55	---	74.00	54.00	-12.45	Peak
N/A										
N/A										
N/A										
N/A										
N/A										

Notes:

1. Measuring frequencies from 1 GHz to the 10th harmonic of highest fundamental frequency.
2. Measurements above show only up to 6 maximum emissions noted, or would be lesser if no specific emissions from the EUT are recorded (ie: margin > 20dB from the applicable limit) and considered that's already beyond the background noise floor.
3. Radiated emissions measured in frequency above 1000MHz were made with an instrument using Peak detector mode and average detector mode of the emission shown in Actual FS column.
4. Spectrum setting:
 - a. Peak Setting 1GHz - 26GHz, RBW = 1MHz, VBW = 1MHz, Sweep time = 200 ms.
 - b. AV Setting 1GHz - 26GHz, RBW = 1MHz, VBW = 10Hz, Sweep time = 200 ms.



Operation Mode: TX / IEEE 802.11b / CH High

Test Date: May 10, 2004

Temperature: 20°C

Tested by: Max Yao

Humidity: 70 % RH

Polarity: Ver. / Hor.

Freq. (MHz)	Ant. Pol H/V	Peak Reading (dBuV)	AV Reading (dBuV)	Ant. / CL CF (dB)	Actual Fs		Peak Limit (dBuV/m)	AV Limit (dBuV/m)	Margin (dB)	Remark
					Peak (dBuV/m)	AV (dBuV/m)				
1386.67	V	55.50	---	-8.31	47.19	---	74.00	54.00	-6.81	Peak
4924.00	V	41.50	---	3.51	45.01	---	74.00	54.00	-8.99	Peak
N/A										
N/A										
N/A										
N/A										
1396.67	H	50.50	---	-8.27	42.23	---	74.00	54.00	-11.77	Peak
N/A										
N/A										
N/A										
N/A										
N/A										

Notes:

1. Measuring frequencies from 1 GHz to the 10th harmonic of highest fundamental frequency.
2. Measurements above show only up to 6 maximum emissions noted, or would be lesser if no specific emissions from the EUT are recorded (ie: margin > 20dB from the applicable limit) and considered that's already beyond the background noise floor.
3. Radiated emissions measured in frequency above 1000MHz were made with an instrument using Peak detector mode and average detector mode of the emission shown in Actual FS column.
4. Spectrum setting:
 - a. Peak Setting 1GHz - 26GHz, RBW = 1MHz, VBW = 1MHz, Sweep time = 200 ms.
 - b. AV Setting 1GHz - 26GHz, RBW = 1MHz, VBW = 10Hz, Sweep time = 200 ms.



Operation Mode: TX / IEEE 802.11g / CH Low

Test Date: May 10, 2004

Temperature: 20°C

Tested by: Max Yao

Humidity: 70 % RH

Polarity: Ver. / Hor.

Freq. (MHz)	Ant. Pol H/V	Peak Reading (dBuV)	AV Reading (dBuV)	Ant. / CL CF (dB)	Actual Fs		Peak Limit (dBuV/m)	AV Limit (dBuV/m)	Margin (dB)	Remark
					Peak (dBuV/m)	AV (dBuV/m)				
1323.33	V	49.34	---	-8.57	40.77	---	74.00	54.00	-13.23	Peak
1386.67	V	54.50	---	-8.31	46.19	---	74.00	54.00	-7.81	Peak
N/A										
N/A										
N/A										
N/A										
1393.33	H	48.50	---	-8.29	40.21	---	74.00	54.00	-13.79	Peak
N/A										
N/A										
N/A										
N/A										
N/A										

Notes:

1. Measuring frequencies from 1 GHz to the 10th harmonic of highest fundamental frequency.
2. Measurements above show only up to 6 maximum emissions noted, or would be lesser if no specific emissions from the EUT are recorded (ie: margin > 20dB from the applicable limit) and considered that's already beyond the background noise floor.
3. Radiated emissions measured in frequency above 1000MHz were made with an instrument using Peak detector mode and average detector mode of the emission shown in Actual FS column.
4. Spectrum setting:
 - a. Peak Setting 1GHz - 26GHz, RBW = 1MHz, VBW = 1MHz, Sweep time = 200 ms.
 - b. AV Setting 1GHz - 26GHz, RBW = 1MHz, VBW = 10Hz, Sweep time = 200 ms.



Operation Mode: TX / IEEE 802.11g / CH Mid

Test Date: May 10, 2004

Temperature: 20°C

Tested by: Max Yao

Humidity: 70 % RH

Polarity: Ver. / Hor.

Freq. (MHz)	Ant. Pol H/V	Peak Reading (dBuV)	AV Reading (dBuV)	Ant. / CL CF (dB)	Actual Fs		Peak Limit (dBuV/m)	AV Limit (dBuV/m)	Margin (dB)	Remark
					Peak (dBuV/m)	AV (dBuV/m)				
1326.67	V	49.34	---	-8.55	40.79	---	74.00	54.00	-13.21	Peak
1393.33	V	53.84	---	-8.29	45.55	---	74.00	54.00	-8.45	Peak
N/A										
N/A										
N/A										
N/A										
N/A										
N/A										
N/A										
N/A										
N/A										
N/A										
N/A										

Notes:

1. Measuring frequencies from 1 GHz to the 10th harmonic of highest fundamental frequency.
2. Measurements above show only up to 6 maximum emissions noted, or would be lesser if no specific emissions from the EUT are recorded (ie: margin > 20dB from the applicable limit) and considered that's already beyond the background noise floor.
3. Radiated emissions measured in frequency above 1000MHz were made with an instrument using Peak detector mode and average detector mode of the emission shown in Actual FS column.
4. Spectrum setting:
 - a. Peak Setting 1GHz - 26GHz, RBW = 1MHz, VBW = 1MHz, Sweep time = 200 ms.
 - b. AV Setting 1GHz - 26GHz, RBW = 1MHz, VBW = 10Hz, Sweep time = 200 ms.



Operation Mode: TX / IEEE 802.11g / CH High

Test Date: May 10, 2004

Temperature: 20°C

Tested by: Max Yao

Humidity: 70 % RH

Polarity: Ver. / Hor.

Freq. (MHz)	Ant. Pol H/V	Peak Reading (dBuV)	AV Reading (dBuV)	Ant. / CL CF (dB)	Actual Fs		Peak Limit (dBuV/m)	AV Limit (dBuV/m)	Margin (dB)	Remark
					Peak (dBuV/m)	AV (dBuV/m)				
1396.67	V	54.84	---	-8.27	46.57	---	74.00	54.00	-7.43	Peak
4166.67	V	42.00	---	2.64	44.64	---	74.00	54.00	-9.36	Peak
N/A										
N/A										
N/A										
N/A										
1386.67	H	49.50	---	-8.31	41.19	---	74.00	54.00	-12.81	Peak
N/A										
N/A										
N/A										
N/A										
N/A										

Notes:

1. Measuring frequencies from 1 GHz to the 10th harmonic of highest fundamental frequency.
2. Measurements above show only up to 6 maximum emissions noted, or would be lesser if no specific emissions from the EUT are recorded (ie: margin > 20dB from the applicable limit) and considered that's already beyond the background noise floor.
3. Radiated emissions measured in frequency above 1000MHz were made with an instrument using Peak detector mode and average detector mode of the emission shown in Actual FS column.
4. Spectrum setting:
 - a. Peak Setting 1GHz - 26GHz, RBW = 1MHz, VBW = 1MHz, Sweep time = 200 ms.
 - b. AV Setting 1GHz - 26GHz, RBW = 1MHz, VBW = 10Hz, Sweep time = 200 ms.



7.7 POWERLINE CONDUCTED EMISSIONS

LIMIT

For an intentional radiator which is designed to be connected to the public utility (AC) power line, the radio frequency voltage that is conducted back onto the AC power line on any frequency or frequencies within the band 150 kHz to 30 MHz shall not exceed 250 microvolts (The limit decreases linearly with the logarithm of the frequency in the range 0.15 MHz to 0.50 MHz). The limits at specific frequency range is listed as follows:

Frequency Range (MHz)	Limits (dB μ V)	
	Quasi-peak	Average
0.15 to 0.50	66 to 56	56 to 46
0.50 to 5	56	46
5 to 30	60	50

Compliance with this provision shall be based on the measurement of the radio frequency voltage between each power line (LINE and NEUTRAL) and ground at the power terminals.

MEASUREMENT EQUIPMENT USED

Name of Equipment	Manufacturer	Model	Serial Number	Calibration Due
EMI Test Receiver	R&S	ESCS30	847793/012	12/20/2004
LISN	R&S	ESH2-Z5	843285/010	12/15/2004
LISN	EMCO	3825/2	9003-1628	07/25/2004

Remark: Each piece of equipment is scheduled for calibration once a year.

Test Configuration

See test photographs attached in Appendix 1 for the actual connections between EUT and support equipment.

TEST PROCEDURE

1. The EUT was placed on a table, which is 0.8m above ground plane.
2. Maximum procedure was performed on the six highest emissions to ensure EUT compliance.
3. Repeat above procedures until all frequency measured were complete.



TEST RESULTS

The initial step in collecting conducted data is a spectrum analyzer peak scan of the measurement range. Significant peaks are then marked as shown on the following data page, and these signals are then quasi-peaked.

Test Data

Operation Mode: TX + RX mode **Test Date:** May 10, 2004
Temperature: 23°C **Humidity:** 60 % RH
Power source: 110VAC / 60Hz **Tested by:** Max Yao

Freq. (MHz)	Q.P. Raw (dBuV)	AVG Raw (dBuV)	Q.P. Limit (dBuV)	AVG Limit (dBuV)	Q.P. Margin (dB)	AVG Margin (dB)	Note
0.150	52.90	---	66.00	---	-13.10	---	L1
2.860	27.10	---	56.00	---	-28.90	---	L1
4.680	28.60	---	56.00	---	-27.40	---	L1
11.180	30.70	---	60.00	---	-29.30	---	L1
13.590	30.50	---	60.00	---	-29.50	---	L1
17.420	31.20	---	60.00	---	-28.80	---	L1
0.150	50.40	---	66.00	---	-15.60	---	L2
1.300	27.50	---	56.00	---	-28.50	---	L2
3.380	28.70	---	56.00	---	-27.30	---	L2
4.810	30.20	---	56.00	---	-25.80	---	L2
6.240	29.60	---	60.00	---	-30.40	---	L2
19.820	29.60	---	60.00	---	-30.40	---	L2

Note:

1. Measuring frequencies from 0.15 MHz to 30MHz.
2. The emissions measured in frequency range from 0.15 MHz to 30MHz were made with an instrument using Quasi-peak detector and average detector.
3. “---” denotes the emission level was or more than 2dB below the Average limit
4. The IF bandwidth of SPA between 0.15MHz to 30MHz was 10kHz; the IF bandwidth of Test Receiver between 0.15MHz to 30MHz was 9kHz;
5. L1 = Line One (Live Line) / L2 = Line Two (Neutral Line)

Test Plots

Conducted emissions (Line 1)

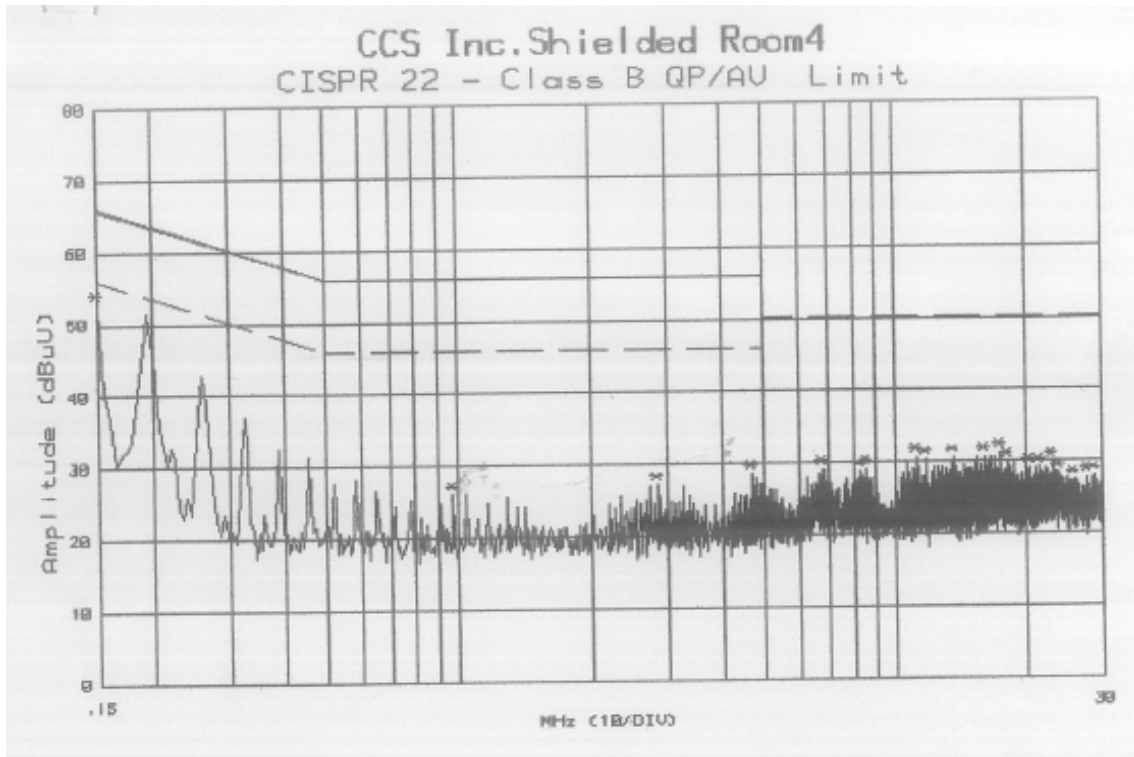

Conducted emissions (Line 2)

