



Prüfbericht-Nr.: <i>Test report no.:</i>	CN23RU3H (P15E-WiFi) 001	Auftrags-Nr.: <i>Order no.:</i>	48220280	Seite 1 von 41 Page 1 of 41
Kunden-Referenz-Nr.: <i>Client reference no.:</i>	N/A	Auftragsdatum: <i>Order date:</i>	2023-06-12	
Auftraggeber: <i>Client:</i>	Nien Made Enterprise Co., Ltd. 23F.-1, No. 98, Shizheng N. 7th Rd., Xitun Dist., Taichung City 407, Taiwan (R.O.C.)			
Prüfgegenstand: <i>Test item:</i>	HUB Gen2			
Bezeichnung / Typ-Nr.: <i>Identification / Type no.:</i>	HUB02			
Auftrags-Inhalt: <i>Order content:</i>	FCC Part 15E Test report (WiFi 5GHz)			
Prüfgrundlage: <i>Test specification:</i>	FCC 47CFR Part 15: Subpart E Section 15.407			
Wareneingangsdatum: <i>Date of sample receipt:</i>	2023-06-07			
Prüfmuster-Nr.: <i>Test sample no.:</i>	A003491261-022 & -056 A003491261-020			
Prüfzeitraum: <i>Testing period:</i>	2023-06-27 - 2023-07-24			
Ort der Prüfung: <i>Place of testing:</i>	EMC/RF Taipei Testing Site			
Prüflaboratorium: <i>Testing laboratory:</i>	Taipei Testing Laboratories			
Prüfergebnis*: <i>Test result*:</i>	Pass			
überprüft von: <i>compiled by:</i>	 Ryan Chen	genehmigt von: <i>authorized by:</i>	 Brenda Chen	
Datum: <i>Date:</i>	2023-08-02	Ausstellungsdatum: <i>Issue date:</i>	2023-08-02	
Stellung / Position:	Senior Project Manager	Stellung / Position:	Senior Project Manager	
Sonstiges / Other:				
Zustand des Prüfgegenstandes bei Anlieferung: <i>Condition of the test item at delivery:</i>		Prüfmuster vollständig und unbeschädigt <i>Test item complete and undamaged</i>		
* Legende:	1 = sehr gut P(ass) = entspricht o.g. Prüfgrundlage(n)	2 = gut F(ail) = entspricht nicht o.g. Prüfgrundlage(n)	3 = befriedigend N/A = nicht anwendbar	4 = ausreichend N/T = nicht getestet
* Legend:	1 = very good P(ass) = passed a.m. test specification(s)	2 = good F(ail) = failed a.m. test specification(s)	3 = satisfactory N/A = not applicable	4 = sufficient N/T = not tested
Dieser Prüfbericht bezieht sich nur auf das o.g. Prüfmuster und darf ohne Genehmigung der Prüfstelle nicht auszugsweise vervielfältigt werden. Dieser Bericht berechtigt nicht zur Verwendung eines Prüfzeichens. <i>This test report only relates to the a. m. test sample. Without permission of the test center this test report is not permitted to be duplicated in extracts. This test report does not entitle to carry any test mark.</i>				

TEST SUMMARY

Report Section	FCC Clause	Test Item	Result
5.1.1	15.407(a) & 15.203	Antenna Requirement	Pass
5.1.2	15.407(a)	Maximum Conducted Output Power	Pass
5.1.3	15.407(h)(1)	Transmit Power Control (TPC)	Pass
5.1.4	15.407(a)	26 dB Bandwidth	Pass
5.1.4	2.1049	99% Occupied Bandwidth	Pass
5.1.5	15.407(e)	6 dB Bandwidth (U-NII-3 Band only)	Pass
5.1.6	15.407(g)	Frequency Stability	Pass
5.1.7	15.407(a)	Power Spectral Density	Pass
5.1.8	15.407(b) & 15.205 & 15.209	Radiated Spurious Emissions and Band Edges	Pass
5.1.9	15.407(h) & KDB 905462 D02	Dynamic Frequency Selection	Pass
5.2.1	15.207	Mains Conducted Emission	Pass

Note: Determining compliance based on the results of the compliance measurement, not taking into account measurement instrumentation uncertainty.

Contents

HISTORY OF THIS TEST REPORT	5
1. GENERAL REMARKS	6
1.1 COMPLEMENTARY MATERIALS.....	6
1.2 DECISION RULE OF CONFORMITY	6
2. TEST SITES	7
2.1 TEST LABORATORY	7
2.2 TEST FACILITY.....	7
2.3 TRACEABILITY	8
2.4 CALIBRATION	8
2.5 MEASUREMENT UNCERTAINTY	8
3. GENERAL PRODUCT INFORMATION.....	9
3.1 PRODUCT FUNCTION AND INTENDED USE	9
3.2 SYSTEM DETAILS AND RATINGS.....	9
3.3 NOISE GENERATING AND NOISE SUPPRESSING PARTS	10
3.4 SUBMITTED DOCUMENTS.....	10
4. TEST SET-UP AND OPERATION MODES.....	11
4.1 PRINCIPLE OF CONFIGURATION SELECTION	11
4.2 CARRIER FREQUENCY AND CHANNEL.....	12
4.3 TEST OPERATION AND TEST SOFTWARE.....	13
4.4 SPECIAL ACCESSORIES AND AUXILIARY EQUIPMENT	15
4.5 TEST SETUP DIAGRAM	16
4.6 DUTY CYCLE OF TEST SIGNAL	17
5. TEST RESULTS	18
5.1 TRANSMITTER REQUIREMENT & TEST SUITES.....	18
5.1.1 <i>Antenna Requirement</i>	<i>18</i>
5.1.2 <i>Maximum Conducted Output Power</i>	<i>19</i>
5.1.3 <i>Transmit Power Control (TPC).....</i>	<i>23</i>
5.1.4 <i>26 dB Bandwidth and 99% Occupied Bandwidth.....</i>	<i>24</i>
5.1.5 <i>6 dB Bandwidth (5725-5850MHz).....</i>	<i>25</i>
5.1.6 <i>Frequency Stability Measurement.....</i>	<i>26</i>
5.1.7 <i>Power Spectral Density.....</i>	<i>28</i>
5.1.8 <i>Radiated Spurious Emissions</i>	<i>30</i>
5.1.9 <i>Dynamic Frequency Selection</i>	<i>35</i>
5.2 MAINS EMISSION	40
5.2.1 <i>Mains Conducted Emission.....</i>	<i>40</i>

Prüfbericht - Nr.: CN23RU3H (P15E-WiFi) 001
Test Report No.

Seite 4 von 41
Page 4 of 41

APPENDIX A - TEST RESULT OF CONDUCTED

APPENDIX B - TEST RESULT OF RADIATED EMISSIONS & MAINS CONDUCTED EMISSION

APPENDIX SP - PHOTOGRAPHS OF TEST SETUP

APPENDIX EP - PHOTOGRAPHS OF EUT

Prüfbericht - Nr.: CN23RU3H (P15E-WiFi) 001
Test Report No.

Seite 5 von 41
Page 5 of 41

HISTORY OF THIS TEST REPORT

Report No.	Description	Date Issued
CN23RU3H (P15E-WiFi) 001	Original Release	2023-08-02

1. General Remarks

1.1 Complementary Materials

All attachments are integral parts of this test report. This applies especially to the following appendix:

Appendix A - Test Result of Conducted

Appendix B - Test Result of Radiated Emissions & Mains Conducted Emission

Appendix SP - Photographs of Test Setup

Appendix EP - Photographs of EUT

Applied Standard and Test Levels

Radio
FCC 47CFR Part 15: Subpart E Section 15.407
FCC 47CFR Part 2: Subpart J Section 2.1049
ANSI C63.10:2013
KDB 789033 D02 General UNII Test Procedures New Rules v02r01
KDB 905462 D02 UNII DFS Compliance Procedures New Rules v02

1.2 Decision Rule of Conformity

The decision rule of conformity of this test report is following the requirements of the requested standard in the quotation, and agreed among testing laboratory and manufacturer (applicant) to exclude the consideration of Measurement Uncertainty, unless it is required by the specific standard.

2. Test Sites

2.1 Test Laboratory

Taipei Testing Laboratories

11F. No.758, Sec. 4, Bade Rd., Songshan Dist.
Taipei City 105
Taiwan (R.O.C.)

2.2 Test Facility

Taipei Testing Laboratories

No.458-18, Sec. 2, Fenliao Rd., Linkou Dist.,
New Taipei City 244
Taiwan (R.O.C.)
FCC Registration No.: 180491
ISED Registration No.: 25563

2.3 Traceability

All measurement equipment calibrations are traceable to NML(Taiwan)/NIST(USA) or where calibration is performed outside Taiwan, to equivalent nationally recognized standards organizations.

2.4 Calibration

Equipment requiring calibration is calibrated periodically in a suitably accredited Calibration Lab. Additionally all equipment is verified for proper performance on a regular basis using in house standards or comparisons.

2.5 Measurement Uncertainty

All measurement uncertainty values are shown with a coverage factor of $k=2$ to indicate a 95% level of confidence.

Emission Measurement Uncertainty

Parameter	Uncertainty
Radiated Emission (9 kHz ~ 30 MHz)	± 1.15 dB
Radiated Emission (30 MHz ~ 200 MHz)	± 1.32 dB
Radiated Emission (200 MHz ~ 1 GHz)	± 1.31 dB
Radiated Emission (1 GHz ~ 18 GHz)	± 1.53 dB
Radiated Emission (18 GHz ~ 40 GHz)	± 2.50 dB
Mains Conducted Emission	± 1.65 dB

3. General Product Information

3.1 Product Function and Intended Use

The EUT is a HUB Gen2. It contains a WLAN compatible module enabling the user to communicate data through a Wireless interface.

For details refer to the User Guide, Data Sheet and Circuit Diagram.

3.2 System Details and Ratings

Basic Information of EUT

Item	EUT information
Kind of Equipment/Test Item	HUB Gen2
Type Identification	HUB02
FCC ID	Q3V-HUB02

Technical Specification of EUT

Item	EUT information
Operating Frequency	Band 1: 5180 MHz ~ 5240 MHz Band 2: 5260 MHz ~ 5320 MHz Band 3: 5500 MHz ~ 5700 MHz Band 4: 5745 MHz ~ 5825 MHz
Channel Number	Band 1: 4 for 802.11a, 802.11n HT20 2 for 802.11n HT40 1 for 802.11ac VHT80 Band 2: 4 for 802.11a, 802.11n HT20 2 for 802.11n HT40 1 for 802.11ac VHT80 Band 3: 8 for 802.11a, 802.11n HT20 4 for 802.11n HT40 1 for 802.11ac VHT80 Band 4: 5 for 802.11a, 802.11n HT20 2 802.11n HT40 1 for 802.11ac VHT80
Data Rate	802.11a: 54.0 / 48.0 / 36.0 / 24.0 / 18.0 / 12.0 / 9.0 / 6.0 Mbps 802.11n: up to MCS7 802.11ac: up to MCS9
Operation Voltage	Adaptor input 100-240 Vac, output 5 Vdc USB 5 Vdc Tested at USB 5Vdc
Modulation	OFDM (BPSK, QPSK, 16QAM, 64QAM, 256QAM)

Item	EUT information
Maximum Output Power (mW)	5180 ~ 5240 MHz: 41.88 5260 ~ 5320 MHz: 50.47 5500 ~ 5720 MHz: 39.26 5745 ~ 5825 MHz: 54.83
Maximum EIRP (mW)	5260 ~ 5320 MHz: 119.12 5500 ~ 5720 MHz: 90.99
DFS Mode	Slave without radar detection
Antenna Information	Refer to 5.1.1
Accessory Device	Refer to 4.4

3.3 Noise Generating and Noise Suppressing Parts

Refer to the Circuit Diagram.

3.4 Submitted Documents

- Circuit Diagram
- Instruction Manual
- Rating Label
- Technical Description

4. Test Set-up and Operation Modes

4.1 Principle of Configuration Selection

The test modes were adapted accordingly in reference to the instructions for use.

During testing, Channel and Power Controlling Software provided by the customer was used to control the operating channel as well as the output power level. The RF output power selection is for the setting of RF output expected by the customer and is going to be fixed on the firmware of the final end product.

Table for Parameters of Test Software Setting

802.11a		802.11n HT20 802.11ac VHT20		802.11n HT40 802.11ac VHT40		802.11ac VHT80	
Channel	Power Setting	Channel	Power Setting	Channel	Power Setting	Channel	Power Setting
36	54	36	55	38	49	42	55
40	55	40	55	46	57	58	54
48	50	48	54	54	58	106	50
52	55	52	59	62	53	155	63
60	55	60	57	102	52		
64	54	64	63	110	63		
100	63	100	63	134	63		
116	63	116	63	151	63		
140	63	140	62	159	63		
149	63	149	63				
157	63	157	63				
165	63	165	63				

4.2 Carrier Frequency and Channel

Band	Channel	Frequency (MHz)	802.11a 802.11n HT20 802.11ac VHT20	802.11n HT40 802.11ac VHT40	802.11ac VHT80
U-NII-1 (Band 1)	36	5180	V		
	38	5190		V	
	40	5200	V		
	42	5210			V
	44	5220	V		
	46	5230		V	
	48	5240	V		
U-NII-2A (Band 2)	52	5260	V		
	54	5270		V	
	56	5280	V		
	58	5290			V
	60	5300	V		
	62	5310		V	
	64	5320	V		
U-NII-2C (Band 3)	100	5500	V		
	102	5510		V	
	104	5520	V		
	106	5530			V
	108	5540	V		
	110	5550		V	
	112	5560	V		
	116	5580	V		
	118	5590		V	
	132	5660	V		
	134	5670		V	
	136	5680	V		
U-NII-3 (Band 4)	140	5700	V		
	149	5745	V		
	151	5755		V	
	153	5765	V		
	155	5775			V
	157	5785	V		
	159	5795		V	
	161	5805	V		
	165	5825	V		

4.3 Test Operation and Test Software

Setup for testing: Test samples are provided with UART interface which makes it possible to control them through a test software installed on a notebook computer.

This software was running on the laptop computer connected to the EUT. It was used to enable the operation modes listed as below.

Test Software	Tera Term
---------------	-----------

The samples were used as follows:

A003491261-022 & -056

A003491261-020

Full test was applied on all test modes, but only worst case was shown.

EUT Configure Mode	Applicable To			Mains Conducted Emission	Description
	Antenna Port Conducted Measurement	Radiated Spurious Emissions above 1 GHz	Radiated Spurious Emissions below 1 GHz		
-	√	√	√	√	-

Note:

1. The EUT had been pre-tested on the positioned of each 3 axis. The worst case was found when position on **Z-plane**.
2. "-" means no effect.

Antenna Port Conducted Measurement

Pre-Scan full test was applied on all test modes, but only worst case was shown.

Following channel(s) was (were) selected for the final test as listed below.

EUT Configure Mode	Mode	Frequency (MHz)	Available Channel	Tested Channel	Date Rate (Mbps)
-	802.11a	5180-5240	36 to 48	36, 40, 48	6.0
-		5260-5320	52 to 64	52, 60, 64	
-		5500-5700	100 to 140	100, 116, 140	
-		5745-5825	149 to 165	149, 157, 165	
-	802.11n HT20 (Power only)	5180-5240	36 to 48	36, 40, 48	MCS0
-		5260-5320	52 to 64	52, 60, 64	
-		5500-5700	100 to 140	100, 116, 140	
-		5745-5825	149 to 165	149, 157, 165	
-	802.11n HT40 (Power only)	5180-5240	38 to 46	38, 46	MCS0
-		5260-5320	54 to 62	54, 62	
-		5500-5700	102 to 134	102, 110, 134	
-		5745-5825	151 to 159	151, 159	
-	802.11ac VHT20	5180-5240	36 to 48	36, 40, 48	NSS1 MCS0
-		5260-5320	52 to 64	52, 60, 64	
-		5500-5700	100 to 140	100, 116, 140	
-		5745-5825	149 to 165	149, 157, 165	
-	802.11ac VHT40	5180-5240	38 to 46	38, 46	NSS1 MCS0
-		5260-5320	54 to 62	54, 62	
-		5500-5700	102 to 134	102, 110, 134	
-		5745-5825	151 to 159	151, 159	
-	802.11ac VHT80	5180-5240	42	42	NSS1 MCS0
-		5260-5320	58	58	
-		5500-5700	106	106	
-		5745-5825	155	155	

Radiated Spurious Emissions (Above 1 GHz)

- Pre-Scan full test was applied on all test modes, but only worst case was shown.
 Following channel(s) was (were) selected for the final test as listed below.

EUT Configure Mode	Mode	Frequency (MHz)	Available Channel	Tested Channel	Date Rate (Mbps)
-	802.11a	5180-5240	36 to 48	36, 40, 48	6.0
-		5260-5320	52 to 64	52, 60, 64	
-		5500-5700	100 to 140	100, 116, 140	
-		5745-5825	149 to 165	149, 157, 165	
-	802.11ac VHT20	5180-5240	36 to 48	36, 40, 48	NSS1 MCS0
-		5260-5320	52 to 64	52, 60, 64	
-		5500-5700	100 to 140	100, 116, 140	
-		5745-5825	149 to 165	149, 157, 165	
-	802.11ac VHT40	5180-5240	38 to 46	38, 46	NSS1 MCS0
-		5260-5320	54 to 62	54, 62	
-		5500-5700	102 to 134	102, 110, 134	
-		5745-5825	151 to 159	151, 159	
-	802.11ac VHT80	5180-5240	42	42	NSS1 MCS0
-		5260-5320	58	58	
-		5500-5700	106	106	
-		5745-5825	155	155	

Radiated Spurious Emissions (Below 1 GHz)

- Pre-Scan full test was applied on all test modes, but only worst case was shown.
 Following channel(s) was (were) selected for the final test as listed below.

EUT Configure Mode	Mode	Frequency (MHz)	Available Channel	Tested Channel	Date Rate (Mbps)
-	802.11ac VHT20	5500-5700	100 to 140	100	NSS1 MCS0

Mains Conducted Emission Test

- Pre-Scan full test was applied on all test modes, but only worst case was shown.
 Following channel(s) was (were) selected for the final test as listed below.

EUT Configure Mode	Mode	Frequency (MHz)	Available Channel	Tested Channel	Date Rate (Mbps)
-	802.11ac VHT20	5500-5700	100 to 140	100	NSS1 MCS0

Test Condition

Test Item	Ambient Temperature	Relative Humidity	Tested by
Conducted Measurement	25.1-25.3 °C	53-54 %	Blake Wang
Radiated Spurious Emissions above 1 GHz	23.7-24.8 °C	54-56 %	Roger Liao
Radiated Spurious Emissions below 1 GHz	23.7-24.8 °C	54-56 %	Roger Liao
Mains Conducted Emission	19.1-25.9 °C	50.2-58.9 %	Ray Huang

4.4 Special Accessories and Auxiliary Equipment

The product has been tested together with the following additional accessories:

Accessory of EUT

No.	Product	Brand	Model	Description
A	USB AM TO TYPE C	台軒電子線材有限公司	11USB-A06-0027	--

Support Unit

Support Unit								
No	Description	Brand	Model	S/N	Shielded	Ferrite Core (Qty)	Length (cm)	Remark
B	Adapter	FULLPOWER	SAW06C-050-1000GB	N/A	-	-	-	--
-	UART	TUV	TUV-001	N/A	NO	NO	15	--
-	Notebook	HP	9470m	CNU4099WK7	-	-	-	--

4.5 Test Setup Diagram

<Radiated Spurious Emissions mode>

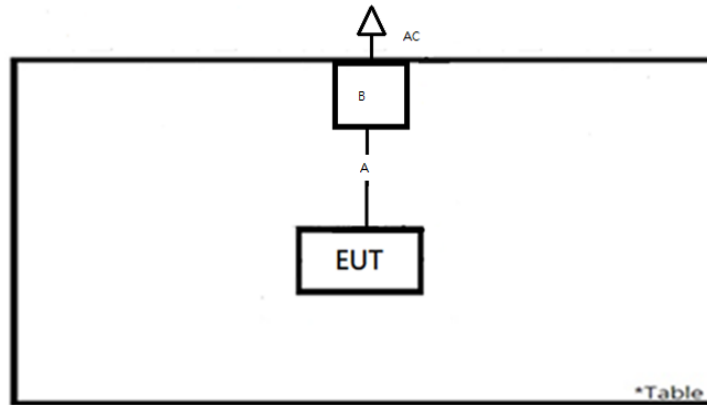

<Mains Conducted Emission mode>

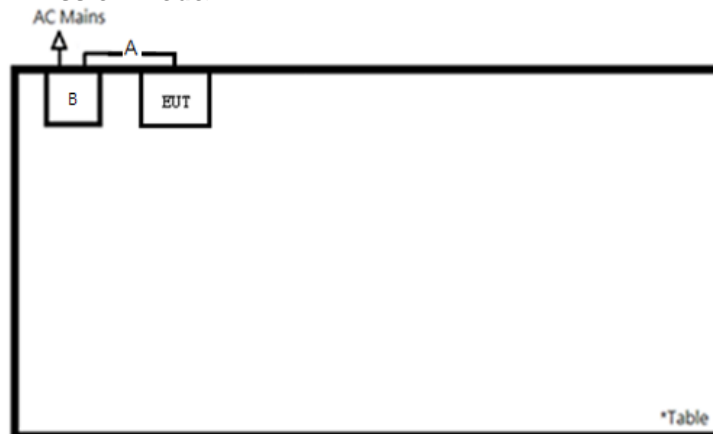

4.6 Duty Cycle of Test Signal

Mode	On + Off Time (ms)	On Time (ms)	Duty Cycle (%)	Duty Factor (dB)
802.11a	2.240	2.065	92.19	0.35
802.11ac VHT20	2.090	1.935	92.58	0.33
802.11ac VHT40	1.044	0.952	91.19	0.40
802.11ac VHT80	0.706	0.462	65.44	1.84

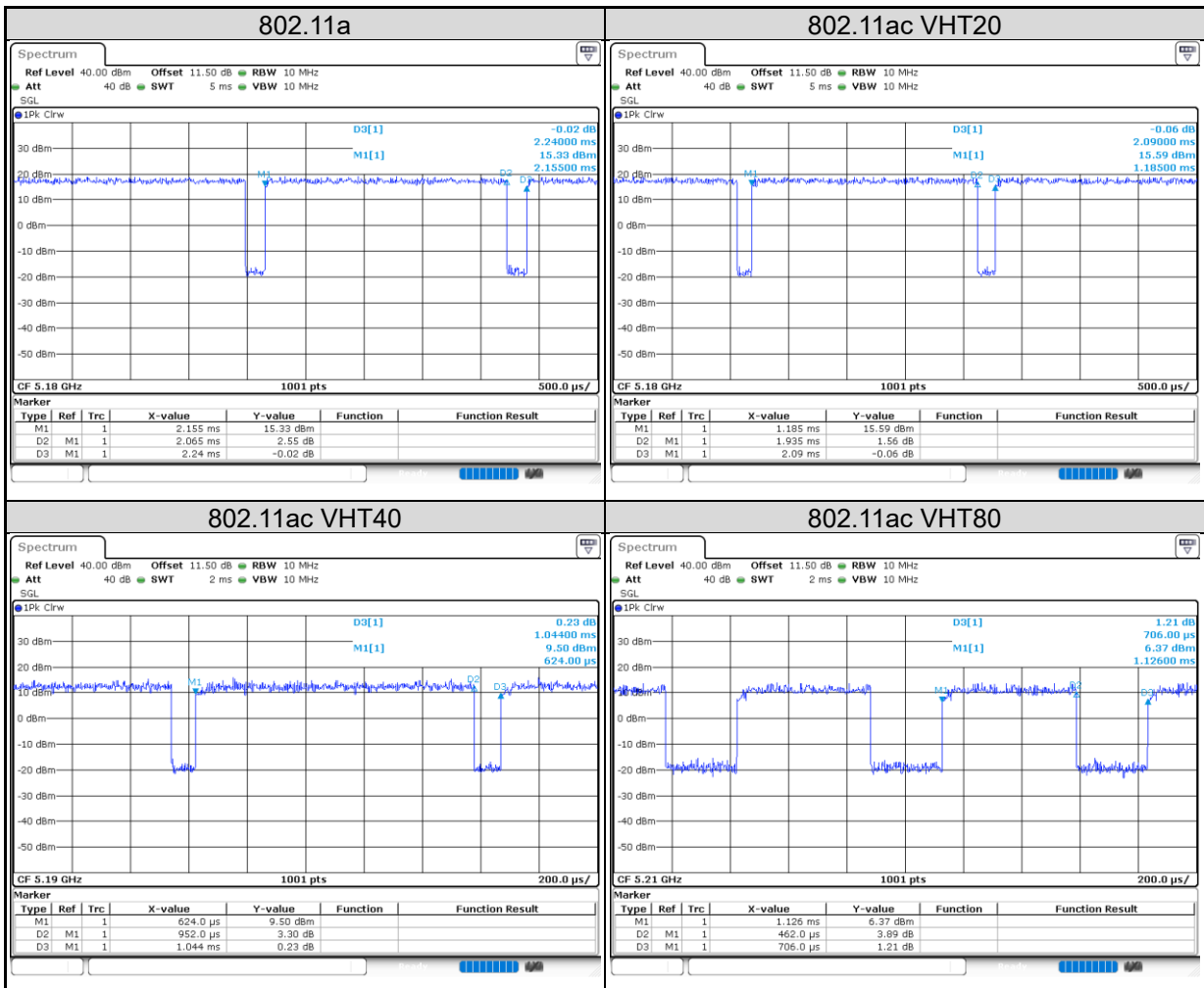

5. Test Results

5.1 Transmitter Requirement & Test Suites

5.1.1 Antenna Requirement

Requirement Use of approved antennas only

According to the manufacturer declaration, the EUT's antenna specifications are described as below. The antenna is used with no possibility of replacement with a non-approved antenna by the end-user. Therefore, the EUT is considered to comply with this provision.

PCB antenna with 3.73 dBi gain (5180 ~ 5240 MHz)

PCB antenna with 3.73 dBi gain (5260 ~ 5320 MHz)

PCB antenna with 3.65 dBi gain (5500 ~ 5700 MHz)

PCB antenna with 3.65 dBi gain (5745 ~ 5825 MHz)

Refer to EUT photo for details.

5.1.2 Maximum Conducted Output Power

Limit

Operation Band	EUT Category	Limit
U-NII-1	Outdoor Access Point	1 Watt (30 dBm) (Max. e.i.r.p \leq 125 mW (21 dBm) at any elevation angle above 30 degrees as measured from the horizon)
	Fixed point-to-point Access Point	1 Watt (30 dBm)
	Indoor Access Point	1 Watt (30 dBm)
	Mobile and Portable client device	250 mW (24 dBm)
U-NII-2A	---	250 mW (24 dBm) or 11 dBm + 10 log B*
U-NII-2C	---	250 mW (24 dBm) or 11 dBm + 10 log B*
U-NII-3	---	1 Watt (30 dBm)

Note: B* is the 26 dB emission bandwidth in megahertz

Kind of Test Site Shielded room

Test Setup



Test Instruments

Kind of Equipment	Manufacturer	Type	S/N	Calibration Date	Calibration Due Date	Test Date	
						From	Until
Power Meter	Anritsu	ML2495A	1901008	2023/3/17	2024/3/15	2023/7/4	2023/7/24
Power Sensor	Anritsu	MA2411B	1725269	2023/3/17	2024/3/15	2023/7/4	2023/7/24

Test Procedures

Method PM is used to perform output power measurement, trigger and gating function of wide band power meter is enabled to measure max output power of TX on burst and set the detector to AVERAGE. Duty factor is not added to measured value.

Test Result
<802.11a>

Channel	Channel Frequency (MHz)	Average Output Power		Limit (dBm)
		(dBm)	(mW)	
36	5180	15.67	36.90	24.00
40	5200	15.22	33.27	24.00
48	5240	13.08	20.32	24.00
52	5260	14.98	31.48	24.00
60	5300	14.69	29.44	24.00
64	5320	13.86	24.32	24.00
100	5500	15.56	35.97	24.00
116	5580	15.28	33.73	24.00
140	5700	15.13	32.58	24.00
149	5745	15.31	33.96	30.00
157	5785	15.81	38.11	30.00
165	5825	16.04	40.18	30.00

Note:
For U-NII-2A, U-NII-2C Band:

1. $11 \text{ dBm} + 10\log(33.13) = 26.20 \text{ dBm} > 24 \text{ dBm}$.
2. $11 \text{ dBm} + 10\log(30.21) = 25.80 \text{ dBm} > 24 \text{ dBm}$.
3. $11 \text{ dBm} + 10\log(26.69) = 25.26 \text{ dBm} > 24 \text{ dBm}$.
4. $11 \text{ dBm} + 10\log(38.12) = 26.81 \text{ dBm} > 24 \text{ dBm}$.
5. $11 \text{ dBm} + 10\log(37.72) = 26.77 \text{ dBm} > 24 \text{ dBm}$.
6. $11 \text{ dBm} + 10\log(37.60) = 26.75 \text{ dBm} > 24 \text{ dBm}$.

<802.11n HT20>

Channel	Channel Frequency (MHz)	Average Output Power		Limit (dBm)
		(dBm)	(mW)	
36	5180	14.96	31.33	24.00
40	5200	15.02	31.77	24.00
48	5240	14.73	29.72	24.00
52	5260	16.22	41.88	24.00
60	5300	15.20	33.11	24.00
64	5320	17.00	50.12	24.00
100	5500	15.62	36.48	24.00
116	5580	15.54	35.81	24.00
140	5700	14.79	30.13	24.00
149	5745	15.23	33.34	30.00
157	5785	15.76	37.67	30.00
165	5825	15.71	37.24	30.00

<802.11n HT40>

Channel	Channel Frequency (MHz)	Average Output Power		Limit (dBm)
		(dBm)	(mW)	
38	5190	15.13	32.58	24.00
46	5230	16.19	41.59	24.00
54	5270	16.04	40.18	24.00
62	5310	14.15	26.00	24.00
102	5510	12.21	16.63	24.00
110	5550	15.79	37.93	24.00
134	5670	15.18	32.96	24.00
151	5755	15.33	34.12	30.00
159	5795	15.97	39.54	30.00

<802.11ac VHT20>

Channel	Channel Frequency (MHz)	Average Output Power		Limit (dBm)
		(dBm)	(mW)	
36	5180	15.05	31.99	24.00
40	5200	15.17	32.89	24.00
48	5240	14.82	30.34	24.00
52	5260	16.31	42.76	24.00
60	5300	15.23	33.34	24.00
64	5320	17.03	50.47	24.00
100	5500	15.71	37.24	24.00
116	5580	15.64	36.64	24.00
140	5700	14.89	30.83	24.00
149	5745	15.31	33.96	30.00
157	5785	15.85	38.46	30.00
165	5825	15.81	38.11	30.00

Note:
For U-NII-2A, U-NII-2C Band:

1. $11 \text{ dBm} + 10\log(36.68) = 26.64 \text{ dBm} > 24 \text{ dBm}$.
2. $11 \text{ dBm} + 10\log(35.52) = 26.51 \text{ dBm} > 24 \text{ dBm}$.
3. $11 \text{ dBm} + 10\log(39.62) = 26.98 \text{ dBm} > 24 \text{ dBm}$.
4. $11 \text{ dBm} + 10\log(38.92) = 26.90 \text{ dBm} > 24 \text{ dBm}$.
5. $11 \text{ dBm} + 10\log(39.94) = 27.01 \text{ dBm} > 24 \text{ dBm}$.
6. $11 \text{ dBm} + 10\log(36.64) = 26.64 \text{ dBm} > 24 \text{ dBm}$.

<802.11ac VHT40>

Channel	Channel Frequency (MHz)	Average Output Power		Limit (dBm)
		(dBm)	(mW)	
38	5190	15.22	33.27	24.00
46	5230	16.22	41.88	24.00
54	5270	16.11	40.83	24.00
62	5310	14.24	26.55	24.00
102	5510	12.33	17.10	24.00
110	5550	15.94	39.26	24.00
134	5670	15.26	33.57	24.00
151	5755	15.64	36.64	30.00
159	5795	16.11	40.83	30.00

Note:
For U-NII-2A, U-NII-2C Band:

1. $11 \text{ dBm} + 10\log(75.36) = 29.77 \text{ dBm} > 24 \text{ dBm}$.
2. $11 \text{ dBm} + 10\log(48.75) = 27.88 \text{ dBm} > 24 \text{ dBm}$.
3. $11 \text{ dBm} + 10\log(43.40) = 27.37 \text{ dBm} > 24 \text{ dBm}$.
4. $11 \text{ dBm} + 10\log(79.08) = 29.98 \text{ dBm} > 24 \text{ dBm}$.
5. $11 \text{ dBm} + 10\log(76.28) = 29.82 \text{ dBm} > 24 \text{ dBm}$.

<802.11ac VHT80>

Channel	Channel Frequency (MHz)	Average Output Power		Limit (dBm)
		(dBm)	(mW)	
42	5210	15.81	38.11	24.00
58	5290	15.29	33.81	24.00
106	5530	12.18	16.52	24.00
155	5775	17.39	54.83	30.00

Note:
For U-NII-2A, U-NII-2C Band:

1. $11 \text{ dBm} + 10\log(126.27) = 32.01 \text{ dBm} > 24 \text{ dBm}$.
2. $11 \text{ dBm} + 10\log(82.48) = 30.16 \text{ dBm} > 24 \text{ dBm}$.

5.1.3 Transmit Power Control (TPC)

Requirement

U-NII devices operating in the 5.25-5.35 GHz band and the 5.47-5.725 GHz band shall employ a TPC mechanism. The U-NII device is required to have capability to operate at least 6 dB below the mean EIRP value of 30 dBm. A TPC mechanism is not required for systems with an e.i.r.p of less than 500 mW.

Maximum EIRP of this device is 119.12 mW which is less than 500mW, therefore, TPC function is not required.

TPC	E.I.R.P.	15.407(h)(1)
	> 500 mW	The TPC mechanism is required for system with an E.I.R.P. of above 500 mW
V	< 500 mW	--

5.1.4 26 dB Bandwidth and 99% Occupied Bandwidth

Kind of Test Site Shielded room

Test Setup

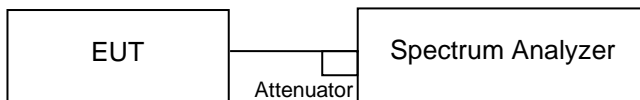

Test Instruments

Kind of Equipment	Manufacturer	Type	S/N	Calibration Date	Calibration Due Date	Test Date	
						From	Until
Spectrum Analyzer	R&S	FSV	101512	2023/2/23	2024/2/22	2023/7/4	2023/7/24
Thermal Chamber	Giant Force	GHT-150-40-CP-SD	MAA1902-010	2023/2/20	2024/2/19	2023/7/4	2023/7/24

Test Procedure

- a. Set RBW = approximately 1% of the emission bandwidth.
- b. Set the VBW > RBW.
- c. Detector = Peak.
- d. Trace mode = max hold.
- e. Measure the maximum width of the emission that is 26 dB down from the peak of the emission. Compare this with the RBW setting of the analyzer. Readjust RBW and repeat measurement as needed until the RBW/EBW ratio is approximately 1%.
- f. For 99% Bandwidth Measurement, the transmitter output was connected to the spectrum analyzer through an attenuator. The bandwidth of the fundamental frequency was measured by spectrum analyzer with resolution bandwidth in the range of 1% to 5% of the anticipated emission bandwidth, and a video bandwidth at least 3x the resolution bandwidth and set the detector to PEAK. The width of a frequency band such that, below the lower and above the upper frequency limits, the mean powers emitted are each equal to a specified percentage 0.5% of the total mean power of a given emission.

Test Results

Please refer to Appendix A

5.1.5 6 dB Bandwidth (5725-5850MHz)

Kind of Test Site Shielded room

Test Setup

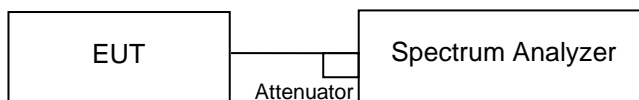

Test Instruments

Kind of Equipment	Manufacturer	Type	S/N	Calibration Date	Calibration Due Date	Test Date	
						From	Until
Spectrum Analyzer	R&S	FSV	101512	2023/2/23	2024/2/22	2023/7/4	2023/7/24
Thermal Chamber	Giant Force	GHT-150-40-CP-SD	MAA1902-010	2023/2/20	2024/2/19	2023/7/4	2023/7/24

Test Procedure

MEASUREMENT PROCEDURE REF

- a. Set resolution bandwidth (RBW) = 100 kHz
- b. Set the video bandwidth (VBW) ≥ 3 x RBW, Detector = Peak.
- c. Trace mode = max hold.
- d. Sweep = auto couple.
- e. Measure the maximum width of the emission that is constrained by the frequencies associated with the two amplitude points (upper and lower) that are attenuated by 6 dB relative to the maximum level measured in the fundamental emission.

Test Results

Please refer to Appendix A

5.1.6 Frequency Stability Measurement

Kind of Test Site Shielded room

Test Setup

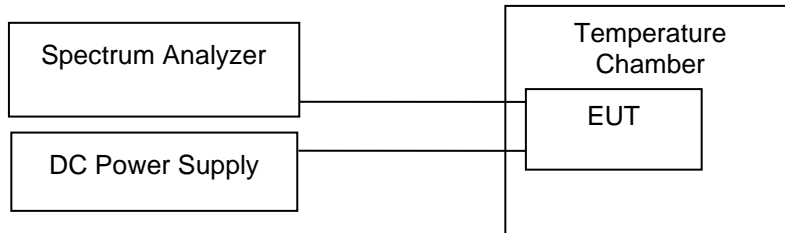

Test Instruments

Kind of Equipment	Manufacturer	Type	S/N	Calibration Date	Calibration Due Date	Test Date	
						From	Until
Spectrum Analyzer	R&S	FSV	101512	2023/2/23	2024/2/22	2023/7/4	2023/7/24
Thermal Chamber	Giant Force	GHT-150-40-CP-SD	MAA1902-010	2023/2/20	2024/2/19	2023/7/4	2023/7/24

Test Procedure

- a. To ensure emission at the band edge is maintained within the authorized band, those values shall be measured by radiation emissions at upper and lower frequency points, and finally compensated by frequency deviation as procedures below.
- b. The EUT was operated at the maximum output power, and connected to the spectrum analyzer, which is set to maximum hold function and peak detector. The peak value of the power envelope was measured and noted. The upper and lower frequency points were respectively measured relatively 10 dB lower than the measured peak value.
- c. The frequency deviation was calculated by adding the upper frequency point and the lower frequency point divided by two. Those detailed values of frequency deviation are provided in table below.

Test Report No.
Test Results

Frequency (MHz)	5180			
Voltage (V)	Measurement Frequency (MHz)			Max. Deviation (ppm)
132	5180.021129			4.079
120	5180.001954			0.377
108	5180.018255			3.524
Temperature (°C)	Measurement Frequency (MHz)			
	0 Minute	2 Minute	5 Minute	10 Minute
50	5180.015593	5180.015246	5180.017282	5180.021056
40	5180.009089	5180.006863	5180.007035	5180.010932
30	5180.017004	5180.008907	5180.011178	5180.011679
20	5180.004957	5180.013472	5180.016613	5180.001264
10	5180.004435	5180.013422	5180.020754	5180.004709
0	5180.000733	5180.015585	5180.016837	5180.008787
-10	5180.005155	5180.006345	5180.021366	5180.020622
-20	5180.0041	5180.016823	5180.005347	5180.021117
Max. Deviation (ppm)	3.283	3.248	4.125	4.077

Frequency (MHz)	5785			
Voltage (V)	Measurement Frequency (MHz)			Max. Deviation (ppm)
132	5785.006988			1.208
120	5785.006773			1.171
108	5785.011405			1.971
Temperature (°C)	Measurement Frequency (MHz)			
	0 Minute	2 Minute	5 Minute	10 Minute
50	5785.002954	5785.010791	5785.000081	5785.007342
40	5785.017299	5785.004567	5785.001075	5785.008986
30	5785.019082	5785.018062	5785.011828	5785.008327
20	5785.014301	5785.01439	5785.005727	5785.006266
10	5785.001377	5785.021146	5785.019197	5785.008829
0	5785.000392	5785.000233	5785.012334	5785.015946
-10	5785.002072	5785.011006	5785.002178	5785.001502
-20	5785.017774	5785.016514	5785.001062	5785.017407
Max. Deviation (ppm)	3.587	3.975	3.608	3.272

5.1.7 Power Spectral Density

Limit

For the 5.15~5.25GHz Bands:

For mobile and portable client devices in the 5.15~5.25GHz band, the Maximum Power spectral density shall not exceed 11dBm/MHz. For an indoor access point operating in the band 5.15~5.25GHz, the maximum power spectral density shall not exceed 17dBm/MHz.

For the 5.25~5.35GHz and 5.47~5.725GHz Bands:

The maximum power spectral density shall not exceed 11dBm/MHz.

For the 5.745~5.85GHz Bands:

The maximum power spectral density shall not exceed 30dBm/500kHz.

Kind of Test Site Shielded room

Test Setup

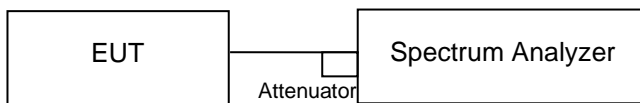

Test Instruments

Kind of Equipment	Manufacturer	Type	S/N	Calibration Date	Calibration Due Date	Test Date	
						From	Until
Spectrum Analyzer	R&S	FSV	101512	2023/2/23	2024/2/22	2023/7/4	2023/7/24
Thermal Chamber	Giant Force	GHT-150-40-CP-SD	MAA1902-010	2023/2/20	2024/2/19	2023/7/4	2023/7/24

Test Procedure**For U-NII-1, U-NII-2A, U-NII-2C band:**

Using method SA-2

1. Set span to encompass the entire emission bandwidth (EBW) of the signal.
2. Set RBW = 1 MHz, Set VBW \geq 3 MHz, Detector = RMS
3. Sweep time = auto, trigger set to "free run".
4. Trace average at least 100 traces in power averaging mode.
5. Record the max value and add 10 log (1/duty cycle)

※For U-NII-3:

1. Set span to encompass the entire emission bandwidth (EBW) of the signal.
2. Set RBW = 500 kHz, Set VBW \geq 3 RBW, Detector = RMS
3. Use the peak marker function to determine the maximum power level in any 500 kHz band segment within the fundamental EBW.
4. Sweep time = auto, trigger set to "free run".
5. Trace average at least 100 traces in power averaging mode.
6. Record the max value and add 10 log (1/duty cycle)

Test Results

Please refer to Appendix A

5.1.8 Radiated Spurious Emissions

Limit

Radiated emissions which fall in the restricted bands, as defined in §15.205(a), must comply with the radiated emission limits specified in §15.209(a).

Emissions radiated outside the restricted and authorized frequency bands must either comply with the radiated emission limits specified for the restricted bands or in §15.407(b).

Kind of Test Site 3m Semi-Anechoic Chamber

Test Setup

<Radiated Emissions below 30 MHz>

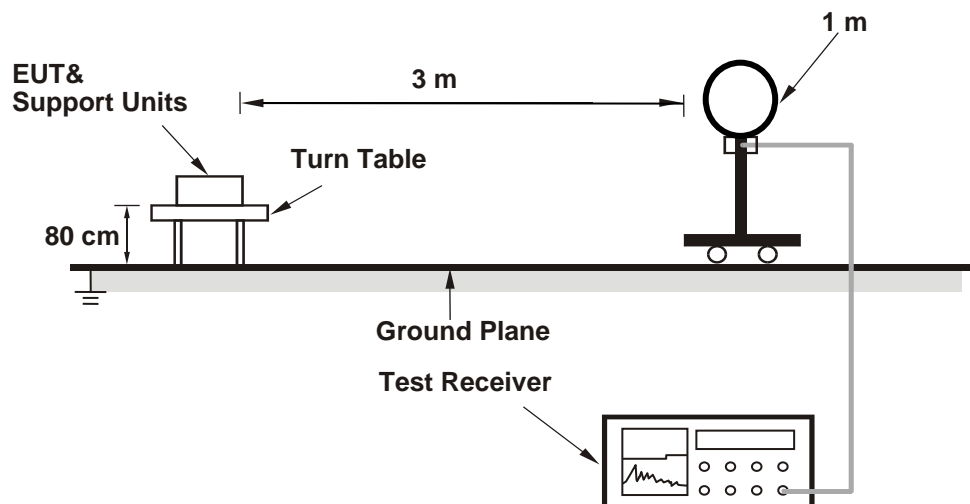

<Radiated Emissions 30 MHz to 1 GHz>

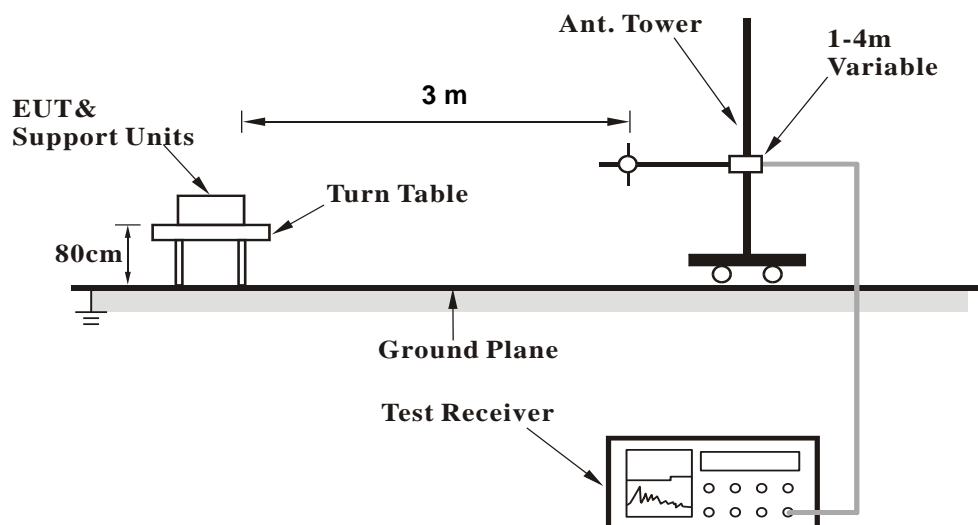

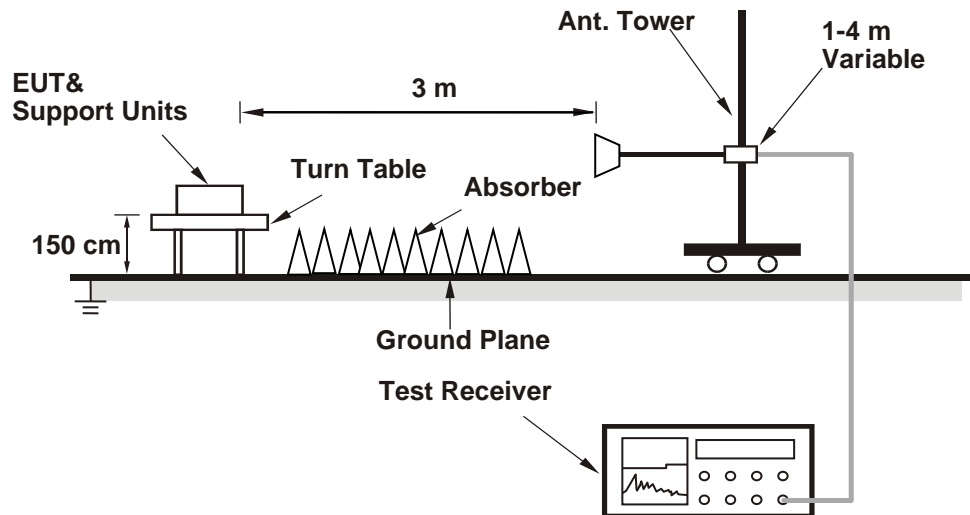
<Radiated Emissions above 1 GHz>

For the actual test configuration, please refer to the attached file (Test Setup Photo).

Test Instruments

Kind of Equipment	Manufacturer	Type	S/N	Calibration Date	Calibration Due Date
Above 1 GHz					
Signal Analyzer	R&S	FSV40	101509	2023/4/26	2024/4/24
Horn Antenna	ETS-Lindgren	3117	00218929	2022/11/17	2023/11/16
Horn Antenna	SCHWARZBECK	BBHA 9170	00890	2023/5/4	2024/5/2
HF-AMP + AC source	EMCI	EMC051845SE	980635	2023/2/16	2024/2/15
HF-AMP + AC source	EMCI	EMC051845SE	980656	2023/1/16	2024/1/15
Test Software	Audix E3	15914a_20191106 tuv	PK-001087	N/A	N/A
30 MHz ~ 1 GHz					
Receiver	R&S	ESR7	102109	2023/2/24	2024/2/23
Bilog Antenna	SCHWARZBECK	VULB-9168	00951	2023/3/31	2024/3/29
LF-AMP	Agilent	8447D	2944A107722	2023/3/22	2024/3/20
Test Software	Audix E3	15914a_20191106 tuv	PK-001087	N/A	N/A
Below 30 MHz					
Receiver	R&S	ESR7	102109	2023/2/24	2024/2/23
Loop Antenna	SCHWARZBECK	FMZB 1519B	00215	2023/1/4	2024/1/3
Test Software	Audix E3	15914a_20191106 tuv	PK-001087	N/A	N/A

Test Procedures**For Radiated Emissions below 30 MHz**

- a. The EUT was placed on the top of a rotating table 0.8 meters above the ground at a 3 meter chamber room. The table was rotated 360 degrees to determine the position of the highest radiation.
- b. The EUT was set 3 meters away from the interference-receiving antenna, which was mounted on the top of a variable-height antenna tower.
- c. Parallel (OPEN), perpendicular (CLOSE), and ground-parallel (GROUND) orientations of the antenna are set to make the measurement.
- d. For each suspected emission, the EUT was arranged to its worst case and the rotatable table was turned from 0 degrees to 360 degrees to find the maximum reading.
- e. The test-receiver system was set to Quasi-Peak Detect Function and Specified Bandwidth with Maximum Hold Mode (the peak detect test results were stricter than Quasi-Peak, therefore, can be assumed that compliance with the regulation.).

Note:

1. The resolution bandwidth and video bandwidth of test receiver/spectrum analyzer is 9 kHz at frequency below 30 MHz.
2. All modes of operation were investigated and the worst-case emissions are reported.

For Radiated Emissions above 30 MHz

- a. The EUT was placed on the top of a rotating table 0.8 meters (for 30 MHz ~ 1 GHz) / 1.5 meters (for above 1 GHz) above the ground at 3 meter chamber room for test. The table was rotated 360 degrees to determine the position of the highest radiation.
- b. The EUT was set 3 meters away from the interference-receiving antenna, which was mounted on the top of a variable-height antenna tower.
- c. The height of antenna is varied from one meter to four meters above the ground to determine the maximum value of the field strength. Both horizontal and vertical polarizations of the antenna are set to make the measurement.
- d. For each suspected emission, the EUT was arranged to its worst case and then the antenna was tuned to heights from 1 meter to 4 meters and the rotatable table was turned from 0 degrees to 360 degrees to find the maximum reading.
- e. The test-receiver system was set to quasi-peak detect function and specified bandwidth with maximum hold mode when the test frequency is below 1 GHz.
- f. The test-receiver system was set to peak and average detected function and specified bandwidth with maximum hold mode when the test frequency is above 1 GHz. If the peak reading value also meets average limit, measurement with the average detector is unnecessary.

Note:

1. The resolution bandwidth and video bandwidth of test receiver/spectrum analyzer is 120 kHz for Quasi-peak detection (QP) or Peak detection (PK) at frequency below 1 GHz.
2. The resolution bandwidth of test receiver/spectrum analyzer is 1 MHz and the video bandwidth is 3 MHz for Peak detection (PK) at frequency above 1 GHz.
3. The resolution bandwidth of test receiver/spectrum analyzer is 1 MHz and the video bandwidth is $\geq 1/T$ (Duty cycle < 98 %) or 10 Hz (Duty cycle ≥ 98 %) for Average detection (AV) at frequency above 1 GHz.
4. All modes of operation were investigated and the worst-case emissions are reported.
5. The Radiated Emissions testing was performed in the X(E1), Y(H) and Z(E2) axis orientation. The worst-case Axis orientation is recorded in this test report.

6. The emission levels of other frequencies (including the 10th harmonic of the highest fundamental frequency) are very lower than the limit and are not shown in the test report.

Test Results

Factor (dB/m) = Antenna Factor (dB/m) + Cable Loss (dB)

Level (dBuV/m) = Reading (dBuV) + Factor (dB/m)

Please refer to Appendix B.

5.1.9 Dynamic Frequency Selection

Limit

<DFS Detection Thresholds for Master Devices and Client Devices with Radar Detection>

Maximum Transmit Power	Value (See Notes 1, 2, and 3)
EIRP \geq 200 milliwatt	-64 dBm
EIRP < 200 milliwatt and power spectral density < 10 dBm/MHz	-62 dBm
EIRP < 200 milliwatt that do not meet the power spectral density requirement	-64 dBm

Note 1: This is the level at the input of the receiver assuming a 0 dBi receive antenna.
 Note 2: Throughout these test procedures an additional 1 dB has been added to the amplitude of the test transmission waveforms to account for variations in measurement equipment. This will ensure that the test signal is at or above the detection threshold level to trigger a DFS response.
 Note 3: EIRP is based on the highest antenna gain. For MIMO devices refer to KDB Publication 662911 D01.

<DFS Response Requirement Values>

Parameter	Value
<i>Non-occupancy period</i>	Minimum 30 minutes
<i>Channel Availability Check Time</i>	60 seconds
<i>Channel Move Time</i>	10 seconds See Note 1.
<i>Channel Closing Transmission Time</i>	200 milliseconds + an aggregate of 60 milliseconds over remaining 10 second period. See Notes 1 and 2.
<i>U-NII Detection Bandwidth</i>	Minimum 100% of the U-NII 99% transmission power bandwidth. See Note 3.

Note 1: *Channel Move Time* and the *Channel Closing Transmission Time* should be performed with Radar Type 0. The measurement timing begins at the end of the Radar Type 0 burst.
 Note 2: The *Channel Closing Transmission Time* is comprised of 200 milliseconds starting at the beginning of the *Channel Move Time* plus any additional intermittent control signals required to facilitate a *Channel* move (an aggregate of 60 milliseconds) during the remainder of the 10 second period. The aggregate duration of control signals will not count quiet periods in between transmissions.
 Note 3: During the *U-NII Detection Bandwidth* detection test, radar type 0 should be used. For each frequency step the minimum percentage of detection is 90 percent. Measurements are performed with no data traffic.

Kind of Test Site Shielded room

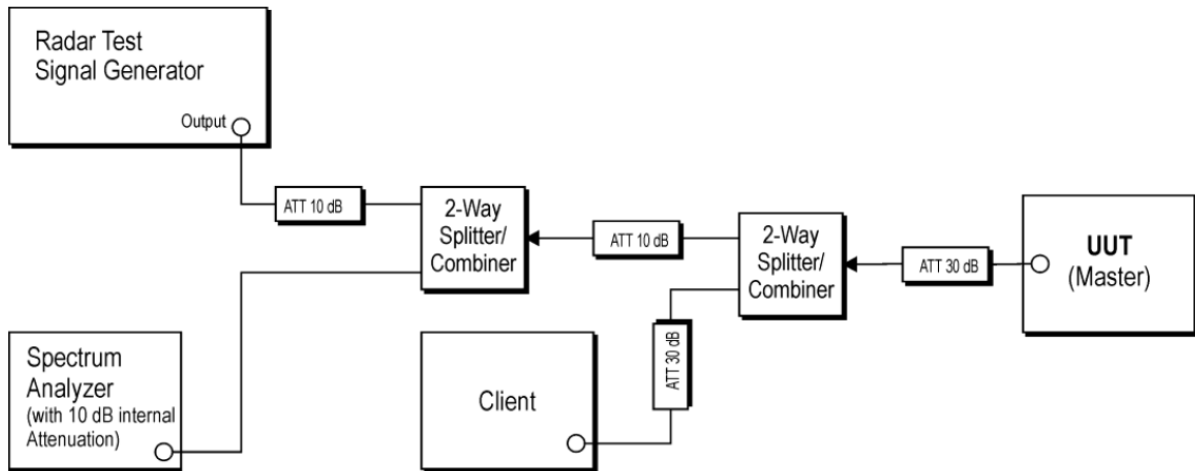
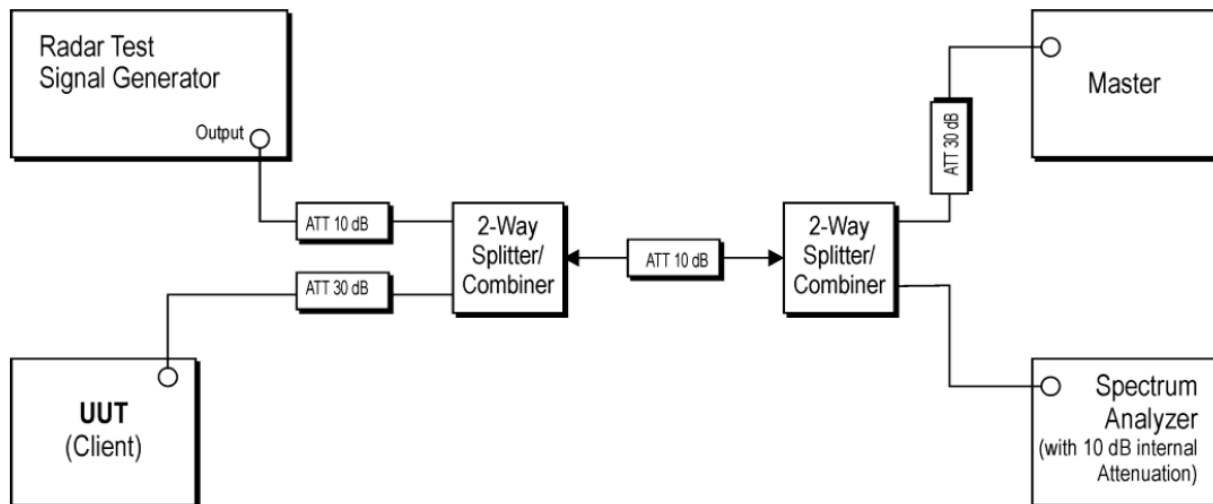
Test Setup
<Setup for Master with injection at the Master>

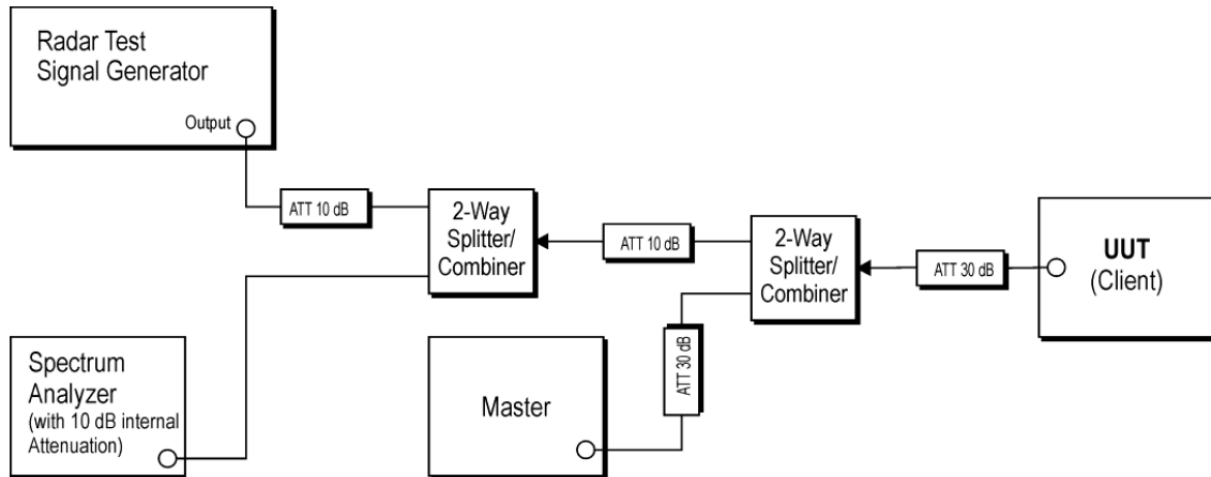
<Setup for Client with injection at the Master>

<Setup for Client with injection at the Client>

Test Instruments

Kind of Equipment	Manufacturer	Type	S/N	Calibration Date	Calibration Due Date	Test Date	
						From	Until
Spectrum Analyzer	Keysight	N9000B	MY62361339	2023/2/11	2024/2/10	2023/7/21	2023/7/21
EXG Vector Signal Generator	Keysight	N5172B	MY61253270	2022/12/6	2023/12/5	2023/7/21	2023/7/21
Frequency Extender	Keysight	N5182BX07	MY61500182	2023/1/19	2024/1/18	2023/7/21	2023/7/21

Requirement

Requirement	Operational Mode	
	Master Device or Client with Radar Detection	Client Without Radar Detection
<i>DFS Detection Threshold</i>	Yes	Not required
<i>Channel Closing Transmission Time</i>	Yes	Yes
<i>Channel Move Time</i>	Yes	Yes
<i>U-NII Detection Bandwidth</i>	Yes	Not required

Additional requirements for devices with multiple bandwidth modes	Master Device or Client with Radar Detection	Client Without Radar Detection
<i>U-NII Detection Bandwidth and Statistical Performance Check</i>	All BW modes must be tested	Not required
<i>Channel Move Time and Channel Closing Transmission Time</i>	Test using widest BW mode available	Test using the widest BW mode available for the link
<i>All other tests</i>	Any single BW mode	Not required

Note: Frequencies selected for statistical performance check (Section 7.8.4) should include several frequencies within the radar detection bandwidth and frequencies near the edge of the radar detection bandwidth. For 802.11 devices it is suggested to select frequencies in each of the bonded 20 MHz channels and the channel center frequency.

Test Results
<802.11ac VHT20>

Non-occupancy period

Channel (MHz)	Limit (minute)	Result
5320	30	Pass
5500	30	Pass



<802.11ac VHT80>

Channel Moving Time

Channel (MHz)	Channel Move Time (s)	Limit (s)	Result
5530	0.324	10	Pass

Channel Closing Transmission Time

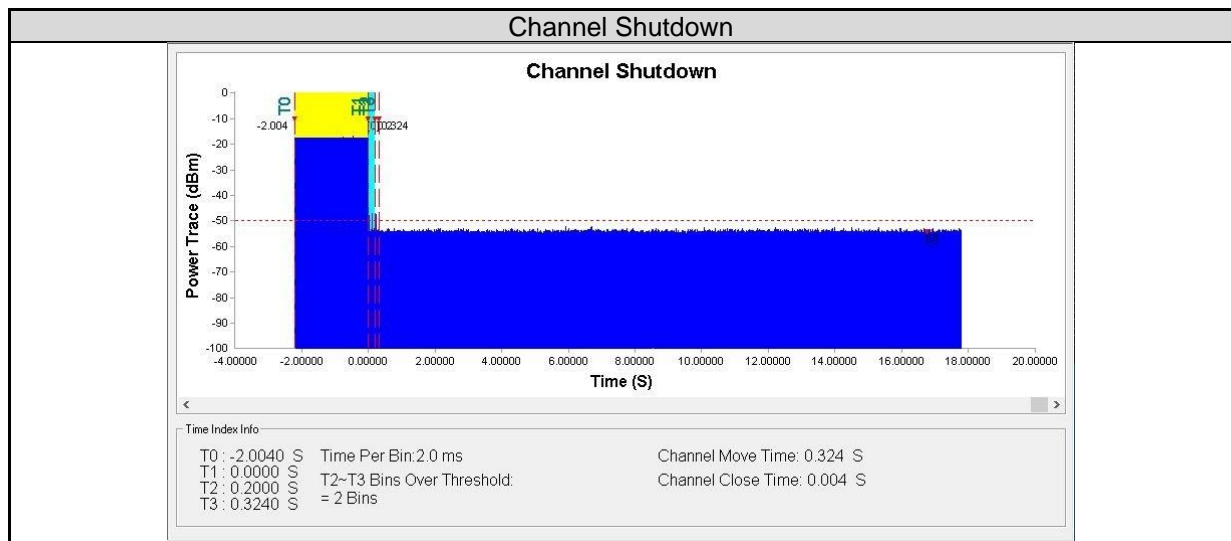
Channel (MHz)	Channel Closing Transmission Time (ms)	Limit (ms)	Result
5530	4	60	Pass

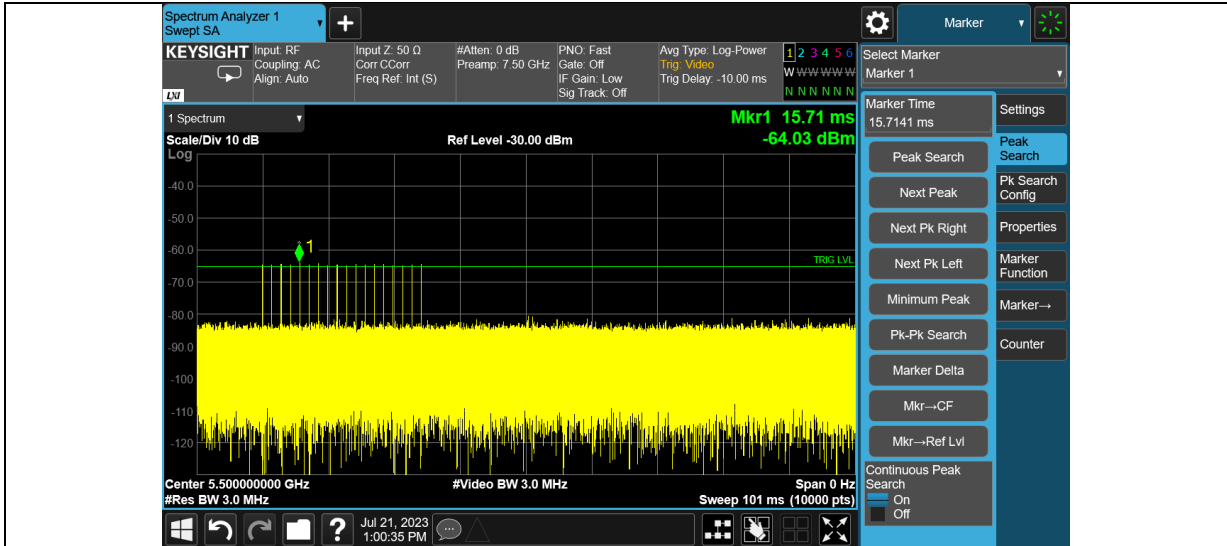

Radar Level

5.2 Mains Emission

5.2.1 Mains Conducted Emission

Limit

Mains Conducted emissions as defined in §15.207 must comply with the mains conducted emission limits.

Kind of Test Site Shielded room

Test Setup

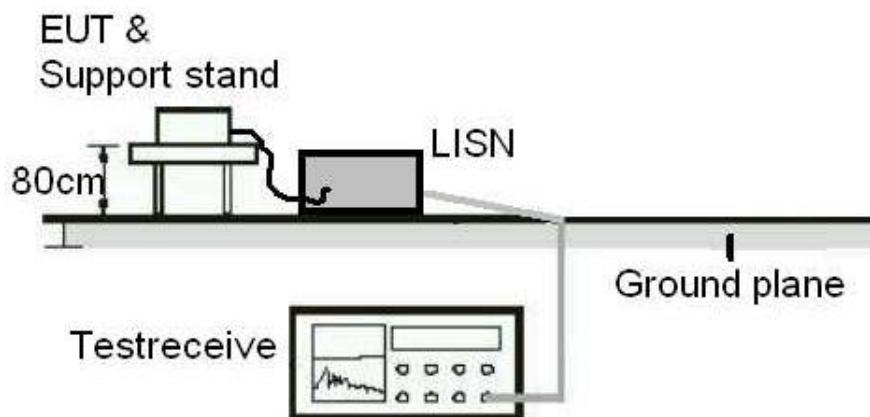

Test Instruments

Kind of Equipment	Manufacturer	Type	S/N	Calibration Date	Calibration Due Date
Two-Line V-Network	Rohde & Schwarz	ENV216	101938	2022/9/22	2023/9/21
EMI Test Receiver	R&S	ESCI	101094	2022/11/24	2023/11/23

Test Procedures

- a. The EUT was placed 0.4 meters from the conducting wall of the shielded room with EUT being connected to the power mains through a line impedance stabilization network (LISN). Other support units were connected to the power mains through another LISN. The two LISNs provide 50 ohm/50 uH of coupling impedance for the measuring instrument.
- b. Both lines of the power mains connected to the EUT were checked for maximum conducted interference.
- c. The frequency range from 150 kHz to 30 MHz was searched. Emission levels under (Limit – 20 dB) was not recorded.

Note: The resolution bandwidth and video bandwidth of test receiver is 9 kHz for quasi-peak detection (QP) and average detection (AV) at frequency 0.15 MHz – 30 MHz.

Test Results

Please refer to Appendix B.