



RF EXPOSURE LAB, LLC

2867 Progress Place, Suite 4D • Escondido, CA 92029 • U.S.A.

TEL (760) 737-3131 • FAX (760) 737-9131

<http://www.rfexposurelab.com>

CERTIFICATE OF COMPLIANCE SAR EVALUATION

Motion Computing
8601 RR2222 Bldg. 2
Austin, TX 78730

Dates of Test: June 15, 16 & 17, 2005
Test Report Number: SAR.20050602
Revision B

FCC ID:	Q3QLS800TS01
Industry Canada Cert:	4587A-LS800
Model(s):	TS01
Serial No.:	Prototype (Identical to Production Unit)
Equipment Type:	PC Tablet
Classification:	Certification
TX Frequency Range:	2412 - 2462 MHz, 5745 - 5805 MHz
Maximum RF Output (Intel):	2.4 GHz – 14.0 dBm, 5.8 GHz – 14.8 dBm
Max. RF Output (Gemtech):	2.4 GHz – 14.3 dBm, 5.8 GHz – 15.0 dBm
Maximum RF Output:	Bluetooth – 10 dBm
Signal Modulation:	DSSS/OFDM/Bluetooth
Antenna Type (Length):	(2) Internal, Part Number DC330018100
Battery:	Sanyo Model BATEAX00L
Standard :	Part 15E, RSS102 with Safety Code 6

This wireless mobile and/or portable device has been shown to be compliant for localized specific absorption rate (SAR) for uncontrolled environment/general exposure limits specified in ANSI/IEEE Std. C95.1-1999 and had been tested in accordance with the measurement procedures specified in IEEE 1528-2003, RSS102 with Safety Code 6 and OET Bulletin 65 Supp. C (See test report).

I attest to the accuracy of the data. All measurements were performed by myself or were made under my supervision and are correct to the best of my knowledge and belief. I assume full responsibility for the completeness of these measurements and vouch for the qualifications of all persons taking them.

Jay M. Moulton
Vice President



Table of Contents

1.	Introduction	3
	SAR Definition [5].....	3
2.	SAR Measurement Setup	4
	Robotic System.....	4
	System Hardware	4
	System Description	4
	E-Field Probe ALS-E-020	5
3.	Robot Specifications	7
4.	Probe and Dipole Calibration	8
5.	Phantom & Simulating Tissue Specifications.....	9
	SAM Phantom.....	9
	Brain & Muscle Simulating Mixture Characterization	9
	Device Holder	9
6.	Body Worn Configurations	10
7.	ANSI/IEEE C95.1 – 1999 RF Exposure Limits [2].....	11
	Uncontrolled Environment.....	11
	Controlled Environment	11
8.	Measurement Uncertainty	12
9.	System Validation	13
	Tissue Verification.....	13
	Test System Verification	13
10.	SAR Test Data Summary	14
	See Measurement Result Data Pages.....	14
	Procedures Used To Establish Test Signal.....	14
	Device Test Condition.....	14
	Device Information on Test Conditions	14
	SAR Data Summary – 5800 MHz Muscle	15
	SAR Data Summary – 2450 MHz Muscle	16
11.	Test Equipment List	17
12.	Conclusion	18
13.	References.....	19
	Appendix A – System Validation Plots and Data	20
	Appendix B – SAR Test Data Plots.....	29
	Appendix C – SAR Test Setup Photos	62
	Appendix D – Probe Calibration Data Sheets.....	69
	Appendix E – Dipole Calibration Data Sheets	90
	Appendix F – Phantom Calibration Data Sheets	110

1. Introduction

This measurement report shows compliance of the Motion Computing Model TS01 FCC ID: Q3QLS800TS01 with FCC Part 2, 1093, ET Docket 93-62 Rules for mobile and portable devices and RSS102 Safety Code 6 of Industry Canada. The FCC has adopted the guidelines for evaluating the environmental effects of radio frequency radiation in ET Docket 93-62 on August 6, 1996 to protect the public and workers from the potential hazards of RF emissions due to FCC regulated portable devices. [1]

The test procedures, as described in ANSI C95.1 – 1999 Standard for Safety Levels with Respect to Human Exposure to Radio Frequency Electromagnetic Fields, 3 kHz to 300 GHz [2], ANSI C95.3 – 2002 Recommended Practice for the Measurement of Potentially Hazardous Electromagnetic Fields [3], FCC OET Bulletin 65 Supp. C – 2001 [4], IEC 62209 and IEEE Std.1528 – 2003 Recommended Practice [5] were employed.

SAR Definition [5]

Specific Absorption Rate is defined as the time derivative (rate) of the incremental energy (dW) absorbed by (dissipated in) an incremental mass (dm) contained in a volume element (dV) of a given density (ρ).

$$SAR = \frac{d}{dt} \left(\frac{dW}{dm} \right) = \frac{d}{dt} \left(\frac{dW}{\rho dV} \right)$$

SAR is expressed in units of watts per kilogram (W/kg). SAR can be related to the electric field at a point by

$$SAR = \frac{\sigma |E|^2}{\rho}$$

where:

σ = conductivity of the tissue (S/m)

ρ = mass density of the tissue (kg/m³)

E = rms electric field strength (V/m)

2. SAR Measurement Setup

Robotic System

The measurements are conducted utilizing the ALSAS-10-U automated dosimetric assessment system. The ALSAS-10-U is designed and manufactured by Aprel Laboratories in Nepean, Ontario, Canada. The system utilizes a Robcomm 3 robot manufactured by ThermoCRS located in Michigan USA.

System Hardware

The system consists of a six axis articulated arm, controller for precise probe positioning (0.05 mm repeatability), a power supply, a teach pendant for teaching area scans, near field probe, an IBM Pentium 4™ 2.66 GHz PC with Windows XP Pro™, and custom software developed to enable communications between the robot controller software and the host operating system.

An amplifier is located on the articulated arm, which is isolated from the custom designed end effector and robot arm. The end effector provides the mechanical touch detection functionality and probe connection interface. The amplifier is functionally validated within the manufacturer's site and calibrated at NCL Calibration Laboratories. A Data Acquisition Card (DAC) is used to collect the signal as detected by the isotropic e-field probe. The DAC manufacturer calibrates the DAC to NIST standards. A formal validation is executed using all mechanical and electronic components to prove conformity of the measurement platform as a whole.

System Description

The ALSAS-10-U has been designed to measure devices within the compliance environment to meet all recognized standards. The system also conforms to standards, which are currently being developed by the scientific and manufacturing community.

The course scan resolution is defined by the operator and reflects the requirements of the standard to which the device is being tested. Precise measurements are made within the predefined course scan area and the values are logged.

The user predefines the sample rate for which the measurements are made so as to ensure that the full duty-cycle of a pulse modulation device is covered during the sample. The following algorithm is an example of the function used by the system for linearization of the output for the probe.

$$V_i = U_i + U_i^2 \bullet \frac{cf}{dcp_i}$$



The April E-Field probe is evaluated to establish the diode compression point.

A complex algorithm is then used to calculate the values within the measured points down to a resolution of 1mm. The data from this process is then used to provide the co-ordinates from which the cube scan is created for the determination of the 1 g and 10 g averages.

Cube scan averaging consists of a number of complex algorithms, which are used to calculate the one, and ten gram averages. The basis for the cube scan process is centered on the location where the maximum measured SAR value was found. When a secondary peak value is found which is within 60% of the initial peak value, the system will report this back to the operator who can then assess the need for further analysis of both the peak values prior to the one and ten-gram cube scan averaging process. The algorithm consists of 3D cubic Spline, and Lagrange extrapolation to the surface, which form the matrix for calculating the measurement output for the one and ten gram average values. The resolution for the physical scan integral is user defined with a final calculated resolution down to 1mm.

In-depth analysis for the differential of the physical scanning resolution for the cube scan analysis has been carried out, to identify the optimum setting for the probe positioning steps, and this has been determined at 8mm increments on the X, & Y planes. The reduction of the physical step increment increased the time taken for analysis but did not provide a better uncertainty or return on measured values.

The final output from the system provides data for the area scan measurements, physical and splined (1mm resolution) cube scan with physical and calculated values (1mm resolution).

The overall uncertainty for the methodology and algorithms the ALSAS-10-U used during the SAR calculation was evaluated using the data from IEEE 1528 f3 algorithm:

$$f_3(x, y, z) = A \frac{a^2}{\frac{a^2}{4} + x'^2 + y'^2} \left(e^{-\frac{2z}{a}} + \frac{a^2}{2(a + 2z)^2} \right)$$

The probe used during the measurement process has been assessed to provide values for diode compression. These values are calculated during the probe calibration exercise and are used in the mathematical calculations for the assessment of SAR.

E-Field Probe ALS-E-020

The E-field probe used by RF Exposure Lab, LLC, has been fully calibrated and assessed for isotropic, and boundary effect. The probe utilizes a triangular sensor arrangement as detailed in the diagram below right.

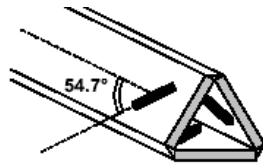

Δ-BEAM

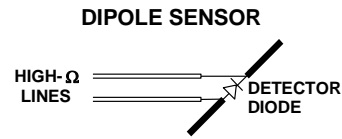

The SAR is assessed with the probe which moves at a default height of 5mm from the center of the diode, which is mounted to the sensor, to the phantom surface (Z height). The diagram above right shows how the center of the sensor is defined with the location of the diode placed at the center of the dipole. The 5mm default in the Z axis is the optimum height for assessing SAR where the boundary effect is at its least, with the probe located closest to the phantom surface (boundary).

3. Robot Specifications

Specifications

Positioner: ThermoCRS, Robot Model: Robocomm 3
Repeatability: 0.05 mm
No. of axis: 6

Data Acquisition Card (DAC) System

Cell Controller

Processor: Pentium 4™
Clock Speed: 2.66 GHz
Operating System: Windows XP Pro™

Data Converter

Features: Signal Amplifier, End Effector, DAC
Software: ALSAS 10-U Software

E-Field Probe

Model: ALS-E-020
Serial Number: 215
Construction: Triangular Core Touch Detection System
Frequency: 10MHz to 6GHz

Phantom

Phantom: Uniphantom, Right Phantom, Left Phantom



4. Probe and Dipole Calibration

See Appendix D and E.

5. Phantom & Simulating Tissue Specifications

SAM Phantom



The Aprel system utilizes three separate phantoms. Each phantom for SAR assessment testing is a low loss dielectric shell, with shape and dimensions derived from the anthropomorphic data of the 90th percentile adult male head dimensions as tabulated by the US Army. The SAM phantom shell is bisected along the mid sagittal plane into right and left halves. The perimeter sidewalls of each phantom half is extended to allow filling with liquid to a depth of 15 cm that is sufficient to minimize reflections from the upper surface [5].

Brain & Muscle Simulating Mixture Characterization

The muscle mixtures consist of a glycol based saline solution and sugar based solution. The mixture is calibrated to obtain proper dielectric constant (permittivity) and conductivity of the desired tissue. The muscle tissue dielectric parameters recommended by the IEEE SCC-34/SC-2 have been incorporated in the following tables. Other head and body tissue parameters that have not been specified in P1528 are derived from the tissue dielectric parameters computed from the 4-Cole-Cole equations.

Table 5.1 Typical Composition of Ingredients for Tissue

Ingredients	Simulating Tissue	
	2450 MHz Muscle	5800 MHz Muscle
Mixing Percentage		
Water	73.20	59.00
DGBE	26.70	0.00
Sugar	0.00	40.6
Salt	0.04	0.00
Bacteriacide	0.00	0.10
HEC	0.00	0.30
Dielectric Constant	Target 52.70	48.20
Conductivity (S/m)	Target 1.95	6.00

Device Holder



In combination with the SAM phantom, the mounting device enables the rotation of the mounted transmitter in spherical coordinates whereby the rotation point is the ear opening. The devices can easily, accurately, and repeatably be positioned according to the FCC specifications. The device holder can be locked at different phantom locations (left head, right head, and uni-phantom).

6. Body Worn Configurations

Body-worn operating configurations are tested with the accessories attached to the device and positioned against a flat phantom in a normal use configuration. A device with a headset output is tested with a headset connected to the device. Body dielectric parameters are used.

Accessories for Body-worn operation configurations are divided into two categories: those that do not contain metallic components and those that do contain metallic components. When multiple accessories that do not contain metallic components are supplied with the device, the device is tested with only the accessory that dictates the closest spacing to the body. Then, when multiple accessories that contain metallic components are supplied with the device, the device is tested with each accessory that contains a unique metallic component. If multiple accessories share an identical metallic component (i.e. the same metallic belt-clip used with different holsters with no other metallic components) only the accessory that dictates the closest spacing to the body is tested.

Body-worn accessories may not always be supplied or available as options for some devices intended to be authorized for body-worn use. In this case, a test configuration where a separation distance between the back of the device and the flat phantom is used. All test position spacings are documented.

Transmitters that are designed to operate in front of a person's face, as in push-to-talk configurations, are tested for SAR compliance with the front of the device positioned to face the flat phantom. For devices that are carried next to the body such as a shoulder, waist or chest-worn transmitters, SAR compliance is tested with the accessory(ies), including headsets and microphones, attached to the device and positioned against a flat phantom in a normal use configuration.

In all cases SAR measurements are performed to investigate the worst-case positioning. Worst-case positioning is then documented and used to perform Body SAR testing.

In order for users to be aware of the body-worn operating requirements for meeting RF exposure compliance, operating instructions and cautions statements are included in the user's manual.

7. ANSI/IEEE C95.1 – 1999 RF Exposure Limits [2]

Uncontrolled Environment

Uncontrolled Environments are defined as locations where there is the exposure of individuals who have no knowledge or control of their exposure. The general population/uncontrolled exposure limits are applicable to situations in which the general public may be exposed or in which persons who are exposed as a consequence of their employment may not be made fully aware of the potential for exposure or cannot exercise control over their exposure. Members of the general public would come under this category when exposure is not employment-related; for example, in the case of a wireless transmitter that exposes persons in its vicinity.

Controlled Environment

Controlled Environments are defined as locations where there is exposure that may be incurred by persons who are aware of the potential for exposure, (i.e. as a result of employment or occupation). In general, occupational/controlled exposure limits are applicable to situations in which persons are exposed as a consequence of their employment, who have been made fully aware of the potential for exposure and can exercise control over their exposure. This exposure category is also applicable when the exposure is of a transient nature due to incidental passage through a location where the exposure levels may be higher than the general population/uncontrolled limits, but the exposed person is fully aware of the potential for exposure and can exercise control over his or her exposure by leaving the area or by some other appropriate means.

Table 8.1 Human Exposure Limits

	UNCONTROLLED ENVIRONMENT General Population (W/kg) or (mW/g)	CONTROLLED ENVIRONMENT Professional Population (W/kg) or (mW/g)
SPATIAL PEAK SAR ¹ Brain	2.00	10.00
SPATIAL AVERAGE SAR ² Whole Body	0.08	0.40
SPATIAL PEAK SAR ¹ Hands, Feet, Ankles, Wrists	4.00	20.00

¹ The Spatial Peak value of the SAR averaged over any 10 gram of tissue (defined as a tissue volume in the shape of a cube) and over the appropriate averaging time.

² The Spatial Average value of the SAR averaged over the whole body.

8. Measurement Uncertainty

See each data scan attached in Appendix B.

9. System Validation

Tissue Verification

Table 10.1 Measured Tissue Parameters

Date(s)		5800 MHz Muscle 16-Jun-2005		2450 MHz Muscle 17-Jun-2005	
Liquid Temperature (°C)	21.0	Target	Measured	Target	Measured
Dielectric Constant: ϵ		48.20	47.80	52.70	52.21
Conductivity: σ		6.000	6.06	1.950	1.980

See Appendix A for data printout.

Test System Verification

Prior to assessment, the system is verified to the $\pm 10\%$ of the specifications at each frequency by using the system kit(s). Muscle Tissue was used to verify the system (Graphic Plots Attached) Linear extrapolation to 1 Watt.

Table 10.2 System Dipole Validation Target & Measured

System Validation Kit Various Kit were used. All listed in the test equipment	Muscle Material	Targeted SAR_{1g} (W/kg)	Measure SAR_{1g} (W/kg)	Deviation (%)
16-Jun-2005	5800	58.3	59.11	1.4
17-Jun-2005	2450	52.4	51.88	-0.9

See Appendix A for data plots.

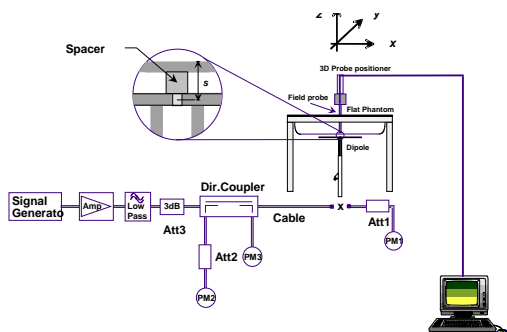

Figure 10.1 Dipole Validation Test Setup

10. SAR Test Data Summary

See Measurement Result Data Pages

See Appendix B for SAR Test Data Plots.
See Appendix C for SAR Test Setup Photos.

Procedures Used To Establish Test Signal

The device was placed into simulated transmit mode using the manufacturer's test codes. Such test signals offer a consistent means for testing SAR and are recommended for evaluating SAR. When test modes are not available or inappropriate for testing a device, the actual transmission is activated through a base station simulator or similar equipment. See data pages for actual procedure used in measurement.

Device Test Condition

The device is battery operated. Each SAR measurement was taken with a fully charged battery.

Device Information on Test Conditions

All power measurements were conducted after the completion of all testing. This is due to the fact that the device needed to be disassembled to complete the measurement. To insure the integrity of the device, the measurement was completed at the end of the testing.

The testing was not performed on the high and low channels because all configurations had an initial mid channel value of greater than 3 dB below the FCC limit.

In the 11b and 11g, the 11g version was tested. Since both had the same transmit power, only the 11g had any testing conducted.

SAR Data Summary – 5800 MHz Muscle

MEASUREMENT RESULTS									
EUT Position	Antenna	Frequency		Modulation	Module Tested	Begin / End Power			SAR (W/kg)
		MHz	Ch.			(dBm)	Battery		
Touch	Main	5765	153	OFDM	Intel		14.8	Standard	0.343
		5765	153	OFDM	Gemtech		15.0	Standard	0.269
	Aux	5765	153	OFDM	Intel		14.6	Standard	0.252
		5765	153	OFDM	Gemtech		14.9	Standard	0.169
	w BT*	5765	153	OFDM	Intel		14.8	Standard	0.470

* Test conducted at the highest SAR with the BT operating.

Muscle
1.6 W/kg (mW/g)
 averaged over 1 gram

1. Battery is fully charged for all tests.
 Power Measured Conducted ERP EIRP
2. SAR Measurement
 Phantom Configuration Left Head Uni-phantom Right Head
 SAR Configuration Head Body
3. Test Signal Call Mode Test Code Base Station Simulator
4. Test Configuration With Holster Without Holster N/A



Jay M. Moulton
 Vice President

SAR Data Summary – 2450 MHz Muscle

MEASUREMENT RESULTS – Operating Mode 11g									
EUT Position	Antenna	Frequency		Modulation	Module Tested	Begin / End Power		SAR (W/kg)	
		MHz	Ch.			(dBm)	Battery		
Touch	Main	2437		OFDM	Intel		14.0	Standard	0.262
		2437		OFDM	Gemtech		14.3	Standard	0.401
	Aux	2437		OFDM	Intel		13.9	Standard	0.232
		2437		OFDM	Gemtech		14.2	Standard	0.239
	w BT*	2437		OFDM	Gemtech		14.3	Standard	0.417
* Test conducted at the highest SAR with the BT operating.						Muscle 1.6 W/kg (mW/g) averaged over 1 gram			

- 5. Battery is fully charged for all tests.
 Power Measured Conducted ERP EIRP
- 6. SAR Measurement
 Phantom Configuration Left Head Uni-phantom Right Head
 SAR Configuration Head Body
- 7. Test Signal Call Mode Test Code Base Station Simulator
- 8. Test Configuration With Holster Without Holster N/A



Jay M. Moulton
 Vice President

11. Test Equipment List

Table 12.1 Equipment Specifications

Type	Calibration Due Date	Serial Number
ThermoCRS Robot	N/A	RAF0338198
ThermoCRS Controller	N/A	RCF0338224
ThermoCRS Teach Pendant (Joystick)	N/A	STP0334405
IBM Computer, 2.66 MHz P4	N/A	8189D8U KCPR08N
Apriel E-Field Probe ALS-E020	06/10/2006	215
Apriel Dummy Probe	N/A	023
Apriel Left Phantom	N/A	RFE-267
Apriel Right Phantom	N/A	RFE-268
Apriel UniPhantom	N/A	RFE-273
Apriel Validation Dipole ALS-D-835-S-2	02/20/2006	RFE-274
Apriel Validation Dipole ALS-D-1900-S-2	02/20/2006	RFE-277
Apriel Validation Dipole ALS-D-2450-S-2	02/20/2006	RFE-278
Apriel Validation Dipole ALS-D-900-S-2	02/20/2006	RFE-275
Apriel Validation Dipole ALS-D-BB-S-2	05/24/2007	235-00801
Agilent (HP) 437B Power Meter	12/14/2005	3125U08837
Agilent (HP) 8481B Power Sensor	12/14/2005	3318A05384
Agilent (HP) 8350B Signal Generator	03/03/2006	2749A10226
Agilent (HP) 83525A RF Plug-In	03/03/2006	2647A01172
Agilent (HP) 8753C Vector Network Analyzer	02/03/2006	3135A01724
Agilent (HP) 85047A S-Parameter Test Set	02/03/2006	2904A00595
Apriel Dielectric Probe Assembly	N/A	0011
Microwave Power Devices 510-10E Amplifier	3/09/2005	6063-001
Microwave Power Devices 1020-9E Amplifier	03/09/2005	5618-1
Brain Equivalent Matter (835 MHz)	N/A	N/A
Brain Equivalent Matter (1900 MHz)	N/A	N/A
Brain Equivalent Matter (900 MHz)	N/A	N/A
Muscle Equivalent Matter (835 MHz)	N/A	N/A
Muscle Equivalent Matter (1900 MHz)	N/A	N/A
Muscle Equivalent Matter (900 MHz)	N/A	N/A
Muscle Equivalent Matter (2450 MHz)	N/A	N/A
Muscle Equivalent Matter (5200 MHz)	N/A	N/A

12. Conclusion

The SAR measurement indicates that the EUT complies with the RF radiation exposure limits of the FCC. These measurements are taken to simulate the RF effects exposure under worst-case conditions. Precise laboratory measures were taken to assure repeatability of the tests. The tested device complies with the requirements in respect to all parameters subject to the test. The test results and statements relate only to the item(s) tested.

Please note that the absorption and distribution of electromagnetic energy in the body is a very complex phenomena that depends on the mass, shape, and size of the body; the orientation of the body with respect to the field vectors; and, the electrical properties of both the body and the environment. Other variables that may play a substantial role in possible biological effects are those that characterize the environment (e.g. ambient temperature, air velocity, relative humidity, and body insulation) and those that characterize the individual (e.g. age, gender, activity level, debilitation, or disease). Because innumerable factors may interact to determine the specific biological outcome of an exposure to electromagnetic fields, any protection guide shall consider maximal amplification of biological effects as a result of field-body interactions, environmental conditions, and physiological variables. [3]

13. References

- [1] Federal Communications Commission, ET Docket 93-62, Guidelines for Evaluating the Environmental Effects of Radio Frequency Radiation, August 1996
- [2] ANSI/IEEE C95.1 – 1999, American National Standard Safety Levels with respect to Human Exposure to Radio Frequency Electromagnetic Fields, 300kHz to 100GHz, New York: IEEE, 1992.
- [3] ANSI/IEEE C95.3 – 2002, IEEE Recommended Practice for the Measurement of Potentially Hazardous Electromagnetic Fields – RF and Microwave, New York: IEEE, 1992.
- [4] Federal Communications Commission, OET Bulletin 65 (Edition 97-01), Supplement C (Edition 01-01), Evaluating Compliance with FCC Guidelines for Human Exposure to Radio Frequency Electromagnetic Fields, July 2001.
- [5] IEEE Standard 1528 – 2003, IEEE Recommended Practice for Determining the Peak-Spatial Average Specific Absorption Rate (SAR) in the Human Head from Wireless Communication Devices: Measurement Techniques, October 2003.

Appendix A – System Validation Plots and Data

```

*****
Test Result for UIM Dielectric Parameter
Thu 16/Jun/2005 10:32:16
Freq Frequency(GHz)
FCC_eH      FCC Bulletin 65 Supplement C ( June 2001) Limits for Head Epsilon
FCC_sH      FCC Bulletin 65 Supplement C (June 2001) Limits for Head Sigma
FCC_eB      FCC Limits for Body Epsilon
FCC_sB      FCC Limits for Body Sigma
Test_e      Epsilon of UIM
Test_s      Sigma of UIM
*****
Freq      FCC_eB      FCC_sB      Test_e      Test_s
5.6850    48.36      5.87      49.61      5.97
5.7050    48.33      5.89      48.99      5.95
5.7250    48.30      5.91      48.50      6.03
5.7450    48.27      5.94      48.58      6.12
5.7650    48.25      5.96      48.52      6.16
5.7850    48.22      5.98      48.63      6.23
5.8050    48.19      6.01      48.57      6.20
5.8250    48.17      6.03      48.26      6.16
5.8450    48.14      6.05      48.10      6.25
5.8650    48.11      6.08      48.08      6.34
    
```

```

*****
Test Result for UIM Dielectric Parameter
Fri 17/Jun/2005 11:10:33
Freq Frequency(GHz)
FCC_eH      FCC Bulletin 65 Supplement C ( June 2001) Limits for Head Epsilon
FCC_sH      FCC Bulletin 65 Supplement C (June 2001) Limits for Head Sigma
FCC_eB      FCC Limits for Body Epsilon
FCC_sB      FCC Limits for Body Sigma
Test_e      Epsilon of UIM
Test_s      Sigma of UIM
*****
Freq      FCC_eB      FCC_sB      Test_e      Test_s
2.1500    53.10      1.66      52.07      1.51
2.2500    52.97      1.76      51.62      1.68
2.3500    52.83      1.85      52.09      1.79
2.4500    52.70      1.95      52.21      1.98
2.5500    52.57      2.09      51.72      2.13
2.6500    52.45      2.23      51.46      2.29
2.7500    52.32      2.38      51.03      2.43
    
```

SAR Test Report

Operator : Jay
Validation Date : 16-Jun-2005
Measurement Date : 16-Jun-2005
Starting Time : 16-Jun-2005 11:14:19 AM
End Time : 16-Jun-2005 11:27:59 AM
Scanning Time : 820 secs

Product Data

Device Name : Validation
Serial No. : 5800
Type : Dipole
Model : ALS-D-BB-S-2
Frequency : 5800.00 MHz
Max. Transmit Pwr : 0.035 W
Drift Time : 0 min(s)
Length : 23.1 mm
Width : 3.6 mm
Depth : 20.7 mm
Antenna Type : Internal
Power Drift-Start : 1.220 W/kg
Power Drift-Finish: 1.196 W/kg
Power Drift (%) : -1.967

Phantom Data

Name : APREL-Uni
Type : Uni-Phantom
Size (mm) : 280 x 280 x 200
Serial No. : System Default
Location : Center
Description : Uni-Phantom

Tissue Data

Type : BODY
Serial No. : 5800
Frequency : 5800 MHz
Last Calib. Date : 16-Jun-2005
Temperature : 21 °C
Ambient Temp. : 24 °C
Humidity : 61 RH%
Epsilon : 47.8 F/m
Sigma : 6.06 S/m
Density : 1000 kg/cu. m

Probe Data

Name : Probe 215 - RFEL
Model : E020
Type : E-Field Triangle
Serial No. : 215
Last Calib. Date : 10-Jun-2005
Frequency : 5800 MHz
Duty Cycle Factor: 1
Conversion Factor: 2.1
Probe Sensitivity: 1.20 1.20 1.20 $\mu\text{V}/(\text{V}/\text{m})^2$
Compression Point: 95 mV
Offset : 1.56 mm

Measurement Data

Crest Factor : 1
Scan Type : Complete
Tissue Temp. : 21°C
Ambient Temp. : 24°C
Set-up Date : 16-Jun-2005
Set-up Time : 11:11:37 AM
Area Scan : 4x5x1 : Measurement x=10mm, y=10mm, z=4mm
Zoom Scan : 5x5x8 : Measurement x=8mm, y=8mm, z=4mm

Other Data

DUT Position : 10 mm
Separation : 0
Channel : Mid - 5800

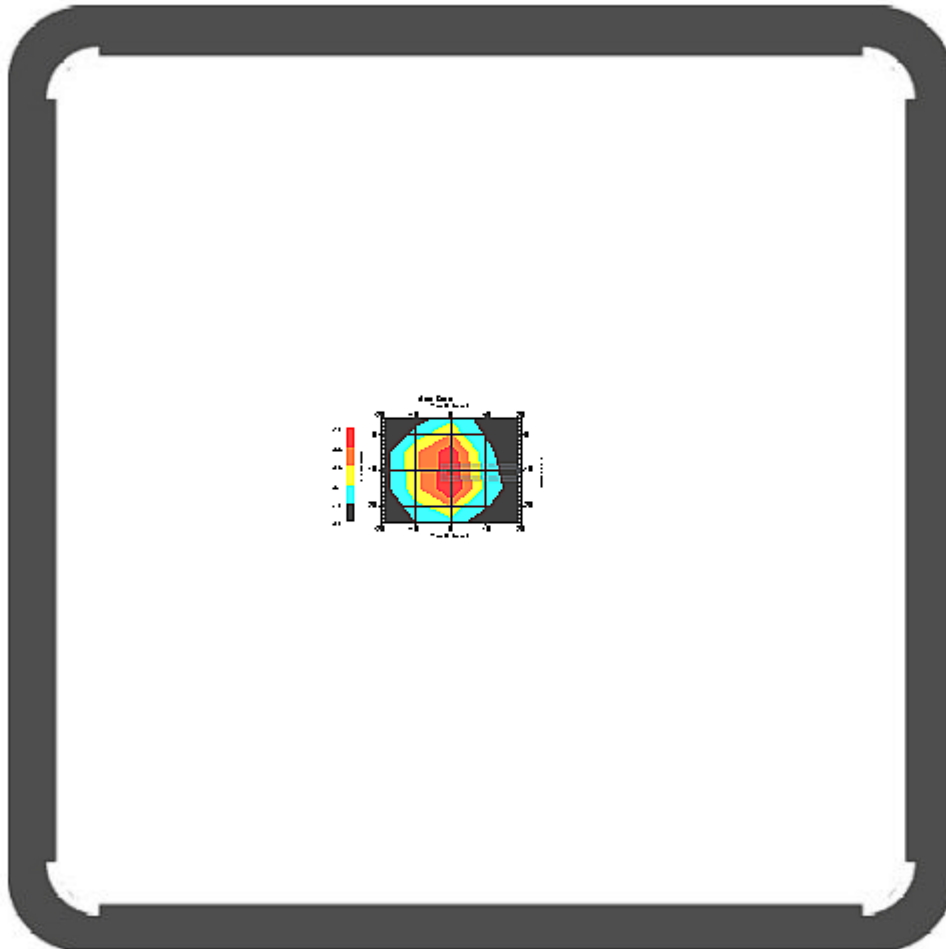

1 gram SAR value : 2.069 W/kg
10 gram SAR value : 0.727 W/kg
Area Scan Peak SAR : 2.098 W/kg
Zoom Scan Peak SAR : 6.445 W/kg

Exposure Assessment Measurement Uncertainty

Source of Uncertainty	Tolerance Value	Probability Distribution	Divisor	c_i^{-1} (1-g)	c_i^{-1} (10-g)	Standard Uncertainty (1-g) %	Standard Uncertainty (10-g) %
Measurement System							
Probe Calibration	3.5	normal	1	1	1	3.5	3.5
Axial Isotropy	3.7	rectangular	•3	$(1-cp)^{1/2}$	$(1-cp)^{1/2}$	1.5	1.5
Hemispherical Isotropy	10.9	rectangular	•3	•cp	•cp	4.4	4.4
Boundary Effect	1.0	rectangular	•3	1	1	0.6	0.6
Linearity	4.7	rectangular	•3	1	1	2.7	2.7
Detection Limit	1.0	rectangular	•3	1	1	0.6	0.6
Readout Electronics	1.0	normal	1	1	1	1.0	1.0
Response Time	0.8	rectangular	•3	1	1	0.5	0.5
Integration Time	1.7	rectangular	•3	1	1	1.0	1.0
RF Ambient Condition	3.0	rectangular	•3	1	1	1.7	1.7
Probe Positioner Mech.	0.4	rectangular	•3	1	1	0.2	0.2
Restriction							
Probe Positioning with respect to Phantom Shell	2.9	rectangular	•3	1	1	1.7	1.7
Extrapolation and Integration	3.7	rectangular	•3	1	1	2.1	2.1
Test Sample Positioning	4.0	normal	1	1	1	4.0	4.0
Device Holder Uncertainty	2.0	normal	1	1	1	2.0	2.0
Drift of Output Power	29.0	rectangular	•3	1	1	16.7	16.7
Phantom and Setup							
Phantom Uncertainty(shape & thickness tolerance)	3.4	rectangular	•3	1	1	2.0	2.0
Liquid Conductivity(target)	5.0	rectangular	•3	0.7	0.5	2.0	1.4
Liquid Conductivity(meas.)	630.1	normal	1	0.7	0.5	441.1	315.1
Liquid Permittivity(target)	5.0	rectangular	•3	0.6	0.5	1.7	1.4
Liquid Permittivity(meas.)	17.6	normal	1	0.6	0.5	10.6	8.8
Combined Uncertainty		RSS				441.6	315.8
Combined Uncertainty (coverage factor=2)		Normal (k=2)				883.3	631.6

SAR-Z Axis at Hotspot x:15.20 y:-2.40

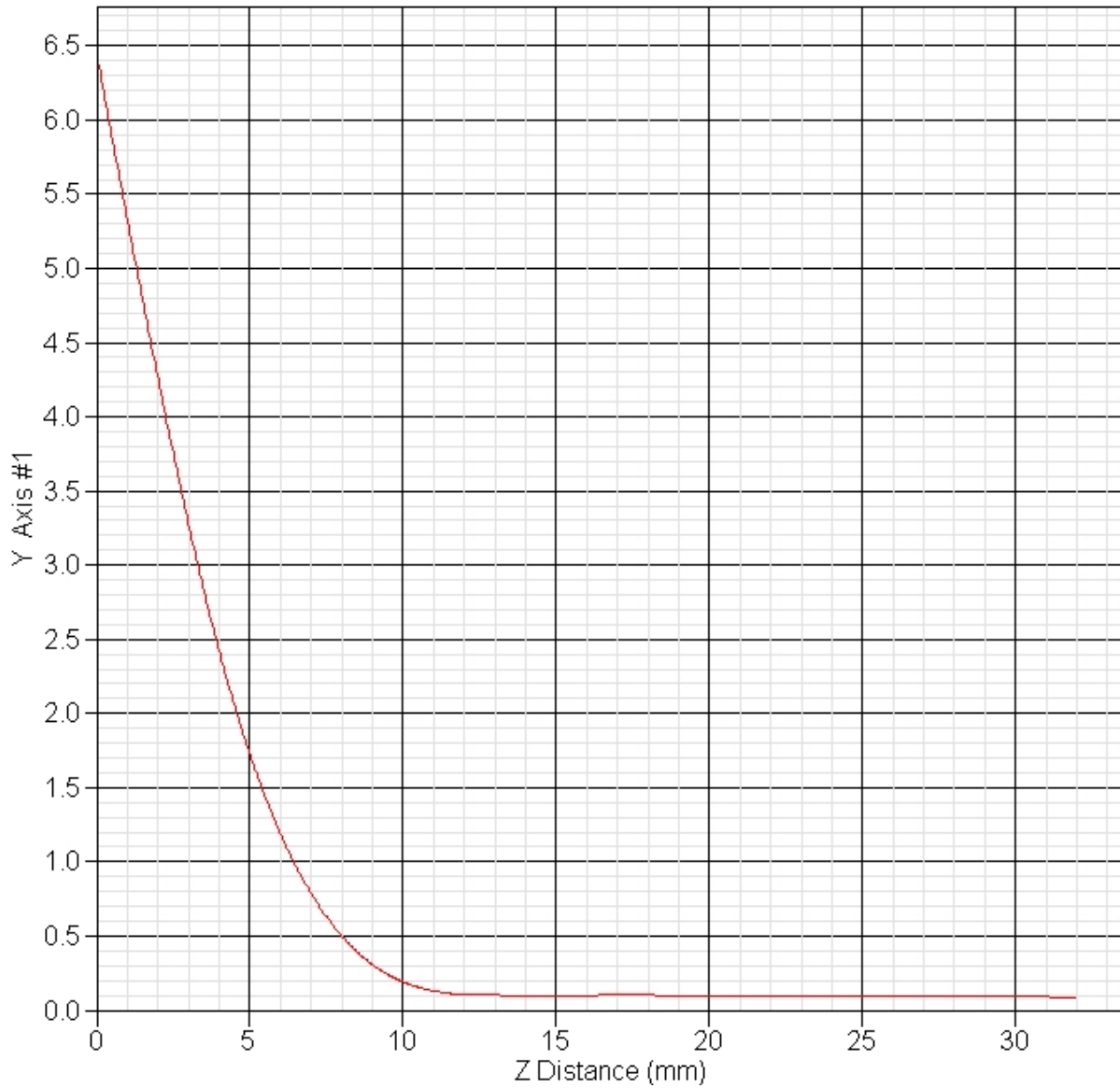

SAR Test Report

Operator : Jay
Validation Date : 17-Jun-2005
Measurement Date : 17-Jun-2005
Starting Time : 17-Jun-2005 12:12:30 PM
End Time : 17-Jun-2005 12:25:50 PM
Scanning Time : 800 secs

Product Data

Device Name : Validation
Serial No. : 2450
Type : Dipole
Model : ALS-D-2450-S-2
Frequency : 2450.00 MHz
Max. Transmit Pwr : 0.1 W
Drift Time : 0 min(s)
Length : 51.5 mm
Width : 3.6 mm
Depth : 30.4 mm
Antenna Type : Internal
Power Drift-Start : 3.566 W/kg
Power Drift-Finish: 3.607 W/kg
Power Drift (%) : 1.150

Phantom Data

Name : APREL-Uni
Type : Uni-Phantom
Size (mm) : 280 x 280 x 200
Serial No. : System Default
Location : Center
Description : Un-Phantom

Tissue Data

Type : BODY
Serial No. : 2450
Frequency : 2450 MHz
Last Calib. Date : 17-Jun-2005
Temperature : 21 °C
Ambient Temp. : 23 °C
Humidity : 51 RH%
Epsilon : 52.21 F/m
Sigma : 1.98 S/m
Density : 1000 kg/cu. m

Probe Data

Name : Probe 215 - RFEL
Model : E020
Type : E-Field Triangle
Serial No. : 215
Last Calib. Date : 10-Jun-2005
Frequency : 2450 MHz
Duty Cycle Factor: 1
Conversion Factor: 3.6
Probe Sensitivity: 1.20 1.20 1.20 $\mu\text{V}/(\text{V}/\text{m})^2$
Compression Point: 95 mV
Offset : 1.56 mm

Measurement Data

Crest Factor : 1
Scan Type : Complete
Tissue Temp. : 21°C
Ambient Temp. : 23°C
Set-up Date : 17-Jun-2005
Set-up Time : 11:40:07 AM
Area Scan : 4x5x1 : Measurement x=10mm, y=10mm, z=4mm
Zoom Scan : 5x5x8 : Measurement x=8mm, y=8mm, z=4mm

Other Data

DUT Position : 10 mm
Separation : 0
Channel : Mid - 2450

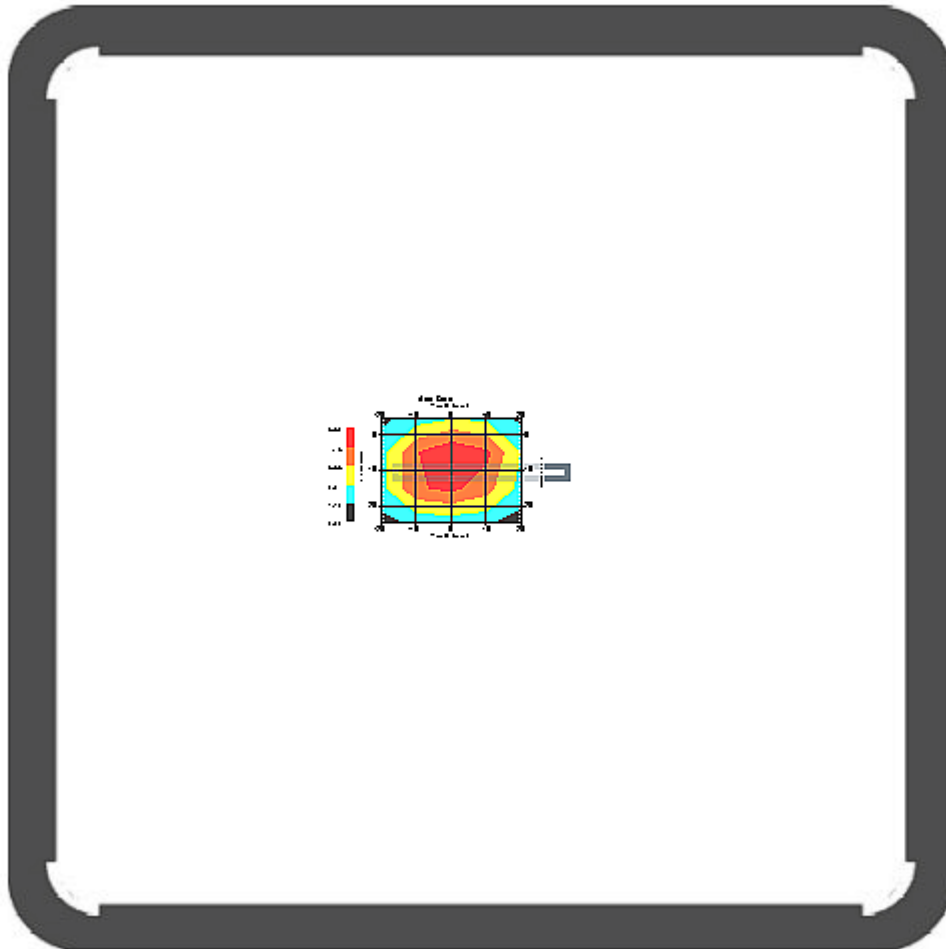

1 gram SAR value : 5.188 W/kg
10 gram SAR value : 2.464 W/kg
Area Scan Peak SAR : 5.599 W/kg
Zoom Scan Peak SAR : 10.290 W/kg

Exposure Assessment Measurement Uncertainty

Source of Uncertainty	Tolerance Value	Probability Distribution	Divisor	c_i^{-1} (1-g)	c_i^{-1} (10-g)	Standard Uncertainty (1-g) %	Standard Uncertainty (10-g) %
Measurement System							
Probe Calibration	3.5	normal	1	1	1	3.5	3.5
Axial Isotropy	3.7	rectangular	•3	$(1-cp)^{1/2}$	$(1-cp)^{1/2}$	1.5	1.5
Hemispherical Isotropy	10.9	rectangular	•3	•cp	•cp	4.4	4.4
Boundary Effect	1.0	rectangular	•3	1	1	0.6	0.6
Linearity	4.7	rectangular	•3	1	1	2.7	2.7
Detection Limit	1.0	rectangular	•3	1	1	0.6	0.6
Readout Electronics	1.0	normal	1	1	1	1.0	1.0
Response Time	0.8	rectangular	•3	1	1	0.5	0.5
Integration Time	1.7	rectangular	•3	1	1	1.0	1.0
RF Ambient Condition	3.0	rectangular	•3	1	1	1.7	1.7
Probe Positioner Mech.	0.4	rectangular	•3	1	1	0.2	0.2
Restriction							
Probe Positioning with respect to Phantom Shell	2.9	rectangular	•3	1	1	1.7	1.7
Extrapolation and Integration	3.7	rectangular	•3	1	1	2.1	2.1
Test Sample Positioning	4.0	normal	1	1	1	4.0	4.0
Device Holder Uncertainty	2.0	normal	1	1	1	2.0	2.0
Drift of Output Power	6.8	rectangular	•3	1	1	3.9	3.9
Phantom and Setup							
Phantom Uncertainty(shape & thickness tolerance)	3.4	rectangular	•3	1	1	2.0	2.0
Liquid Conductivity(target)	5.0	rectangular	•3	0.7	0.5	2.0	1.4
Liquid Conductivity(meas.)	138.6	normal	1	0.7	0.5	97.0	69.3
Liquid Permittivity(target)	5.0	rectangular	•3	0.6	0.5	1.7	1.4
Liquid Permittivity(meas.)	10.0	normal	1	0.6	0.5	6.0	5.0
Combined Uncertainty		RSS				97.7	70.2
Combined Uncertainty (coverage factor=2)		Normal (k=2)				195.4	140.4

SAR-Z Axis
at Hotspot x:13.40 y:-2.50

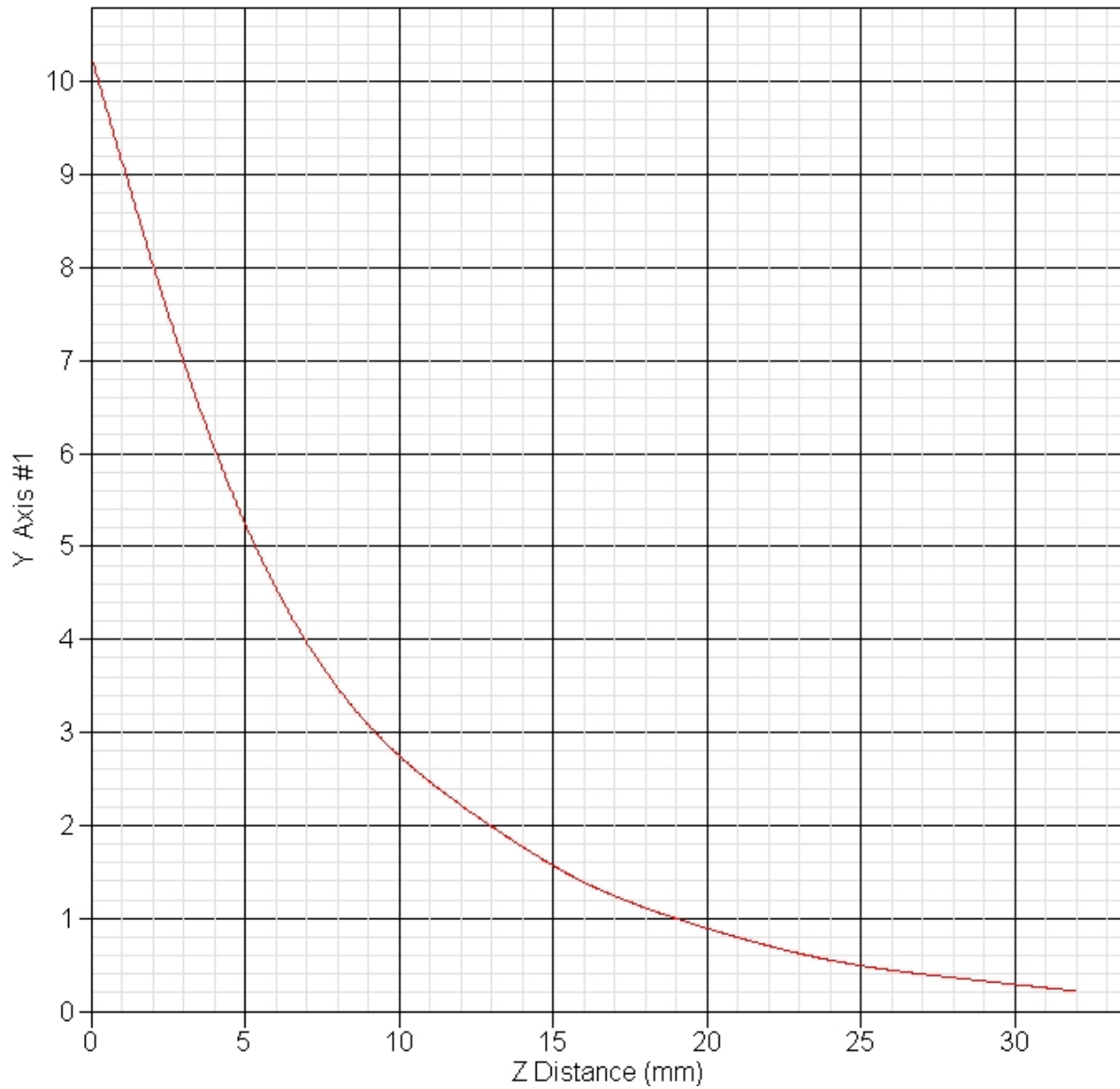

Appendix B – SAR Test Data Plots

SAR Test Report

Operator : Jay
Validation Date : 16-Jun-2005
Measurement Date : 16-Jun-2005
Starting Time : 16-Jun-2005 12:19:22 PM
End Time : 16-Jun-2005 12:32:14 PM
Scanning Time : 772 secs

Product Data

Device Name : Motion Computing
Serial No. : Intel Module Main Antenna
Type : Other
Model : TS01
Frequency : 5800.00 MHz
Max. Transmit Pwr : 0.05 W
Drift Time : 0 min(s)
Length : 200 mm
Width : 170 mm
Depth : 23 mm
Antenna Type : Internal
Power Drift-Start : 0.235 W/kg
Power Drift-Finish: 0.222 W/kg
Power Drift (%) : -5.532

Phantom Data

Name : APREL-Uni
Type : Uni-Phantom
Size (mm) : 280 x 280 x 200
Serial No. : System Default
Location : Center
Description : Uni-Phantom

Tissue Data

Type : BODY
Serial No. : 5800
Frequency : 5800 MHz
Last Calib. Date : 16-Jun-2005
Temperature : 21 °C
Ambient Temp. : 24 °C
Humidity : 61 RH%
Epsilon : 48.52 F/m
Sigma : 6.16 S/m
Density : 1000 kg/cu. m

Probe Data

Name : Probe 215 - RFEL
Model : E020
Type : E-Field Triangle
Serial No. : 215
Last Calib. Date : 10-Jun-2005
Frequency : 5800 MHz
Duty Cycle Factor: 1
Conversion Factor: 2.1
Probe Sensitivity: 1.20 1.20 1.20 $\mu\text{V}/(\text{V}/\text{m})^2$
Compression Point: 95 mV
Offset : 1.56 mm

Measurement Data

Crest Factor : 1
Scan Type : Complete
Tissue Temp. : 21°C
Ambient Temp. : 24°C
Set-up Date : 16-Jun-2005
Set-up Time : 12:17:25 PM
Area Scan : 4x5x1 : Measurement x=10mm, y=10mm, z=4mm
Zoom Scan : 5x5x8 : Measurement x=8mm, y=8mm, z=4mm

Other Data

DUT Position : Touch
Separation : 0
Channel : Mid - 5765

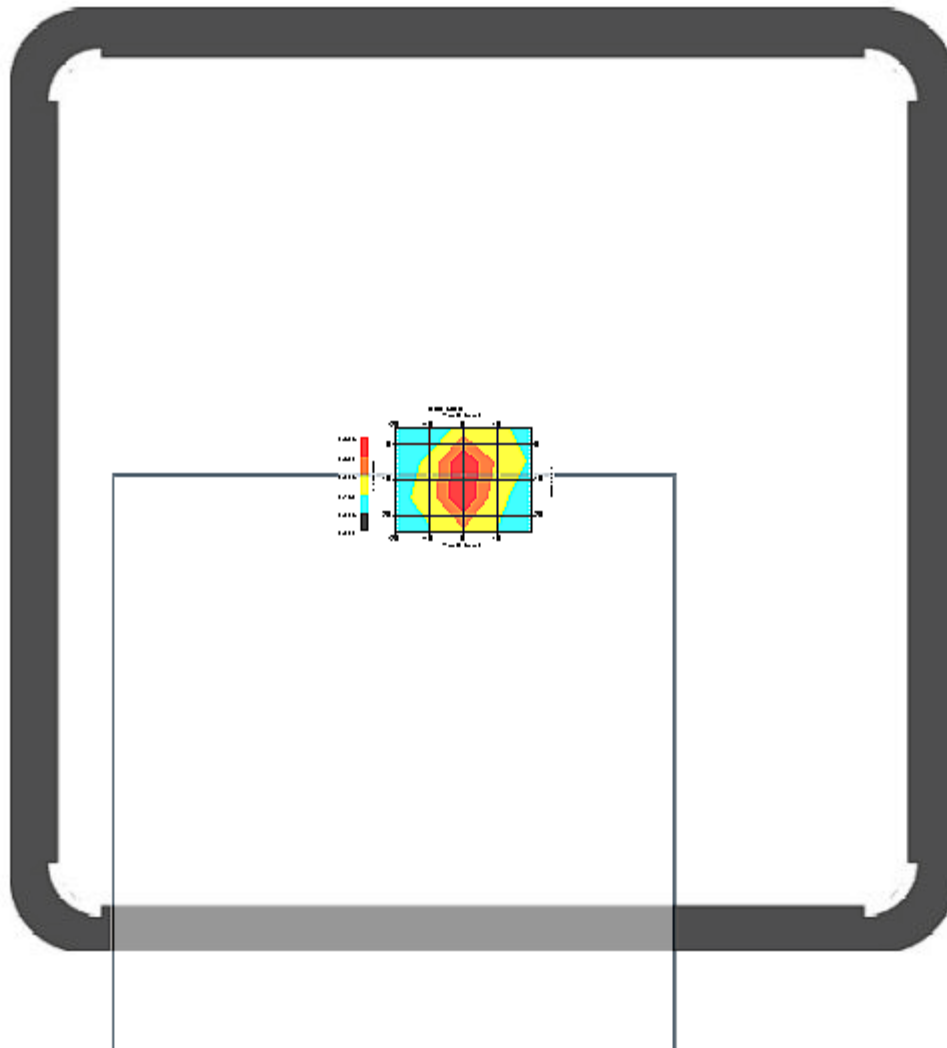

1 gram SAR value : 0.343 W/kg
10 gram SAR value : 0.163 W/kg
Area Scan Peak SAR : 0.375 W/kg
Zoom Scan Peak SAR : 0.980 W/kg

Exposure Assessment Measurement Uncertainty

Source of Uncertainty	Tolerance Value	Probability Distribution	Divisor	c_i^{-1} (1-g)	c_i^{-1} (10-g)	Standard Uncertainty (1-g) %	Standard Uncertainty (10-g) %
Measurement System							
Probe Calibration	3.5	normal	1	1	1	3.5	3.5
Axial Isotropy	3.7	rectangular	•3	$(1-cp)^{1/2}$	$(1-cp)^{1/2}$	1.5	1.5
Hemispherical Isotropy	10.9	rectangular	•3	•cp	•cp	4.4	4.4
Boundary Effect	1.0	rectangular	•3	1	1	0.6	0.6
Linearity	4.7	rectangular	•3	1	1	2.7	2.7
Detection Limit	1.0	rectangular	•3	1	1	0.6	0.6
Readout Electronics	1.0	normal	1	1	1	1.0	1.0
Response Time	0.8	rectangular	•3	1	1	0.5	0.5
Integration Time	1.7	rectangular	•3	1	1	1.0	1.0
RF Ambient Condition	3.0	rectangular	•3	1	1	1.7	1.7
Probe Positioner Mech.	0.4	rectangular	•3	1	1	0.2	0.2
Restriction							
Probe Positioning with respect to Phantom Shell	2.9	rectangular	•3	1	1	1.7	1.7
Extrapolation and Integration	3.7	rectangular	•3	1	1	2.1	2.1
Test Sample Positioning	4.0	normal	1	1	1	4.0	4.0
Device Holder Uncertainty	2.0	normal	1	1	1	2.0	2.0
Drift of Output Power	43.2	rectangular	•3	1	1	24.9	24.9
Phantom and Setup							
Phantom Uncertainty(shape & thickness tolerance)	3.4	rectangular	•3	1	1	2.0	2.0
Liquid Conductivity(target)	5.0	rectangular	•3	0.7	0.5	2.0	1.4
Liquid Conductivity(meas.)	642.2	normal	1	0.7	0.5	449.5	321.1
Liquid Permittivity(target)	5.0	rectangular	•3	0.6	0.5	1.7	1.4
Liquid Permittivity(meas.)	16.3	normal	1	0.6	0.5	9.8	8.2
Combined Uncertainty		RSS				450.4	322.3
Combined Uncertainty (coverage factor=2)		Normal (k=2)				900.8	644.6

SAR Test Report

Operator : Jay
Validation Date : 16-Jun-2005
Measurement Date : 16-Jun-2005
Starting Time : 16-Jun-2005 01:16:04 PM
End Time : 16-Jun-2005 01:28:36 PM
Scanning Time : 752 secs

Product Data

Device Name : Motion Computing
Serial No. : Gemtech Module Main Antenna
Type : Other
Model : TS01
Frequency : 5800.00 MHz
Max. Transmit Pwr : 0.05 W
Drift Time : 0 min(s)
Length : 200 mm
Width : 170 mm
Depth : 23 mm
Antenna Type : Internal
Power Drift-Start : 0.155 W/kg
Power Drift-Finish: 0.150 W/kg
Power Drift (%) : -3.226

Phantom Data

Name : APREL-Uni
Type : Uni-Phantom
Size (mm) : 280 x 280 x 200
Serial No. : System Default
Location : Center
Description : Uni-Phantom

Tissue Data

Type : BODY
Serial No. : 5800
Frequency : 5800 MHz
Last Calib. Date : 16-Jun-2005
Temperature : 21 °C
Ambient Temp. : 24 °C
Humidity : 61 RH%
Epsilon : 48.52 F/m
Sigma : 6.16 S/m
Density : 1000 kg/cu. m

Probe Data

Name : Probe 215 - RFEL
Model : E020
Type : E-Field Triangle
Serial No. : 215
Last Calib. Date : 10-Jun-2005
Frequency : 5800 MHz
Duty Cycle Factor: 1
Conversion Factor: 2.1
Probe Sensitivity: 1.20 1.20 1.20 $\mu\text{V}/(\text{V}/\text{m})^2$
Compression Point: 95 mV
Offset : 1.56 mm

Measurement Data

Crest Factor : 1
Scan Type : Complete
Tissue Temp. : 21°C
Ambient Temp. : 24°C
Set-up Date : 16-Jun-2005
Set-up Time : 1:14:49 PM
Area Scan : 4x5x1 : Measurement x=10mm, y=10mm, z=4mm
Zoom Scan : 5x5x8 : Measurement x=8mm, y=8mm, z=4mm

Other Data

DUT Position : Touch
Separation : 0
Channel : Mid - 5765

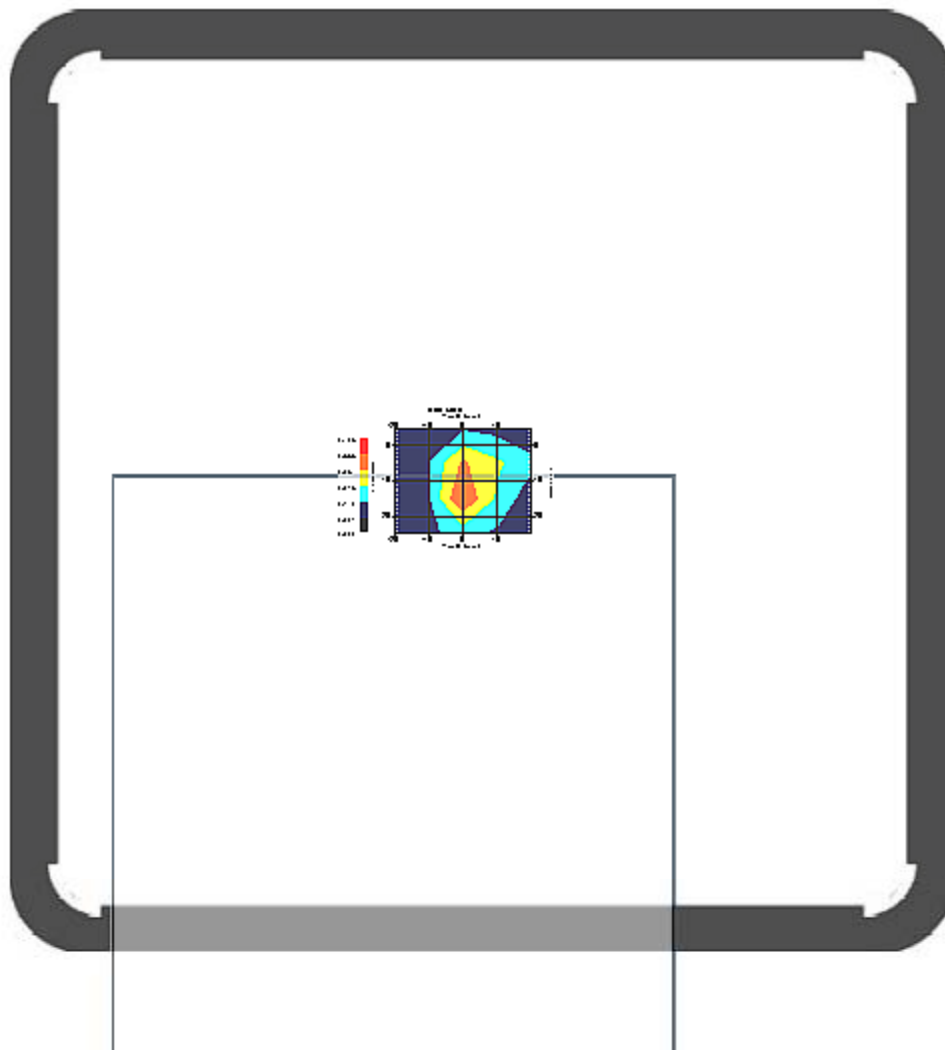

1 gram SAR value : 0.269 W/kg
10 gram SAR value : 0.137 W/kg
Area Scan Peak SAR : 0.356 W/kg
Zoom Scan Peak SAR : 0.750 W/kg

Exposure Assessment Measurement Uncertainty

Source of Uncertainty	Tolerance Value	Probability Distribution	Divisor	c_i^{-1} (1-g)	c_i^{-1} (10-g)	Standard Uncertainty (1-g) %	Standard Uncertainty (10-g) %
Measurement System							
Probe Calibration	3.5	normal	1	1	1	3.5	3.5
Axial Isotropy	3.7	rectangular	•3	$(1-cp)^{1/2}$	$(1-cp)^{1/2}$	1.5	1.5
Hemispherical Isotropy	10.9	rectangular	•3	•cp	•cp	4.4	4.4
Boundary Effect	1.0	rectangular	•3	1	1	0.6	0.6
Linearity	4.7	rectangular	•3	1	1	2.7	2.7
Detection Limit	1.0	rectangular	•3	1	1	0.6	0.6
Readout Electronics	1.0	normal	1	1	1	1.0	1.0
Response Time	0.8	rectangular	•3	1	1	0.5	0.5
Integration Time	1.7	rectangular	•3	1	1	1.0	1.0
RF Ambient Condition	3.0	rectangular	•3	1	1	1.7	1.7
Probe Positioner Mech.	0.4	rectangular	•3	1	1	0.2	0.2
Restriction							
Probe Positioning with respect to Phantom Shell	2.9	rectangular	•3	1	1	1.7	1.7
Extrapolation and Integration	3.7	rectangular	•3	1	1	2.1	2.1
Test Sample Positioning	4.0	normal	1	1	1	4.0	4.0
Device Holder Uncertainty	2.0	normal	1	1	1	2.0	2.0
Drift of Output Power	29.2	rectangular	•3	1	1	16.9	16.9
Phantom and Setup							
Phantom Uncertainty(shape & thickness tolerance)	3.4	rectangular	•3	1	1	2.0	2.0
Liquid Conductivity(target)	5.0	rectangular	•3	0.7	0.5	2.0	1.4
Liquid Conductivity(meas.)	642.2	normal	1	0.7	0.5	449.5	321.1
Liquid Permittivity(target)	5.0	rectangular	•3	0.6	0.5	1.7	1.4
Liquid Permittivity(meas.)	16.3	normal	1	0.6	0.5	9.8	8.2
Combined Uncertainty		RSS				450.0	321.8
Combined Uncertainty (coverage factor=2)		Normal (k=2)				900.0	643.6

SAR Test Report

Operator : Jay
Validation Date : 16-Jun-2005
Measurement Date : 16-Jun-2005
Starting Time : 16-Jun-2005 11:42:45 AM
End Time : 16-Jun-2005 11:55:50 AM
Scanning Time : 785 secs

Product Data

Device Name : Motion Computing
Serial No. : Intel Module Aux Antenna
Type : Other
Model : TS01
Frequency : 5800.00 MHz
Max. Transmit Pwr : 0.05 W
Drift Time : 0 min(s)
Length : 200 mm
Width : 170 mm
Depth : 23 mm
Antenna Type : Internal
Power Drift-Start : 0.127 W/kg
Power Drift-Finish: 0.130 W/kg
Power Drift (%) : 2.362

Phantom Data

Name : APREL-Uni
Type : Uni-Phantom
Size (mm) : 280 x 280 x 200
Serial No. : System Default
Location : Center
Description : Uni-Phantom

Tissue Data

Type : BODY
Serial No. : 5800
Frequency : 5800 MHz
Last Calib. Date : 16-Jun-2005
Temperature : 21 °C
Ambient Temp. : 24 °C
Humidity : 61 RH%
Epsilon : 48.52 F/m
Sigma : 6.16 S/m
Density : 1000 kg/cu. m

Probe Data

Name : Probe 215 - RFEL
Model : E020
Type : E-Field Triangle
Serial No. : 215
Last Calib. Date : 10-Jun-2005
Frequency : 5800 MHz
Duty Cycle Factor: 1
Conversion Factor: 2.1
Probe Sensitivity: 1.20 1.20 1.20 $\mu\text{V}/(\text{V}/\text{m})^2$
Compression Point: 95 mV
Offset : 1.56 mm

Measurement Data

Crest Factor : 1
Scan Type : Complete
Tissue Temp. : 21°C
Ambient Temp. : 24°C
Set-up Date : 16-Jun-2005
Set-up Time : 11:37:19 AM
Area Scan : 4x5x1 : Measurement x=10mm, y=10mm, z=4mm
Zoom Scan : 5x5x8 : Measurement x=8mm, y=8mm, z=4mm

Other Data

DUT Position : Touch
Separation : 0
Channel : Mid - 5765

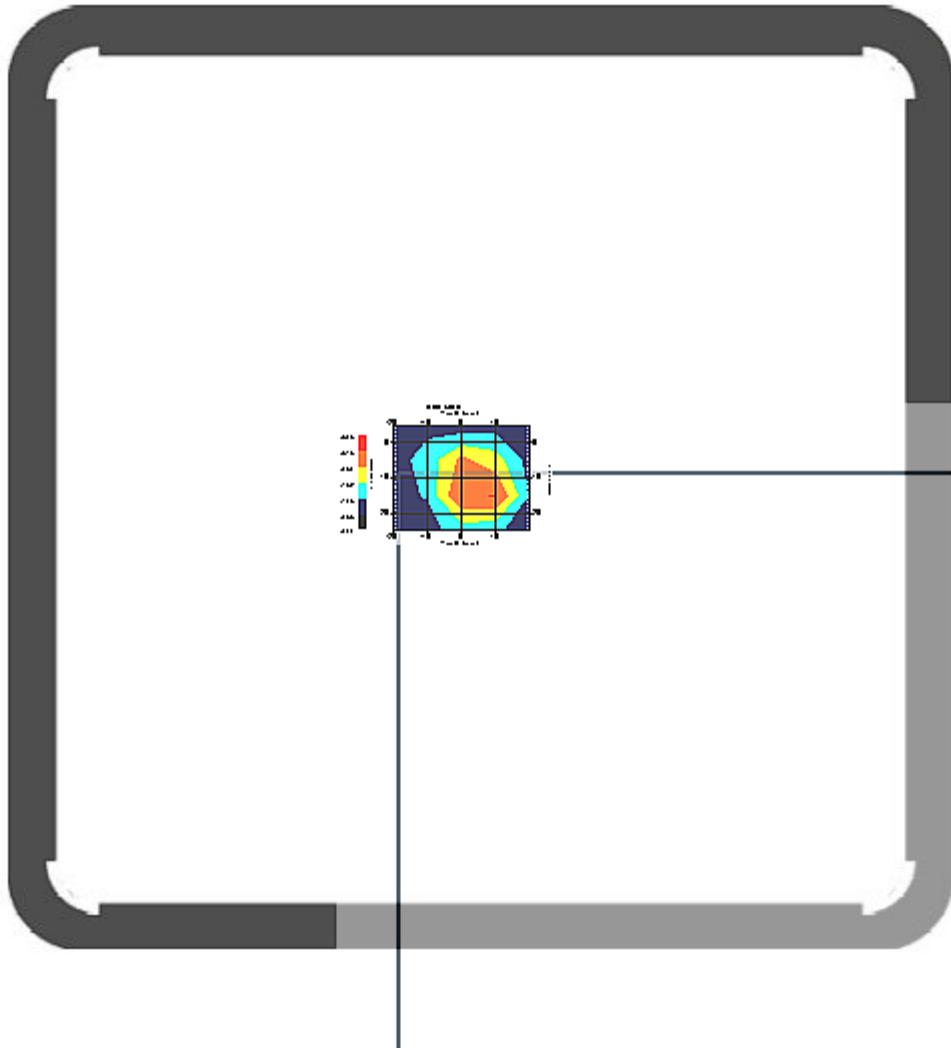

1 gram SAR value : 0.252 W/kg
10 gram SAR value : 0.135 W/kg
Area Scan Peak SAR : 0.316 W/kg
Zoom Scan Peak SAR : 0.700 W/kg

Exposure Assessment Measurement Uncertainty

Source of Uncertainty	Tolerance Value	Probability Distribution	Divisor	c_i^{-1} (1-g)	c_i^{-1} (10-g)	Standard Uncertainty (1-g) %	Standard Uncertainty (10-g) %
Measurement System							
Probe Calibration	3.5	normal	1	1	1	3.5	3.5
Axial Isotropy	3.7	rectangular	•3	$(1-cp)^{1/2}$	$(1-cp)^{1/2}$	1.5	1.5
Hemispherical Isotropy	10.9	rectangular	•3	•cp	•cp	4.4	4.4
Boundary Effect	1.0	rectangular	•3	1	1	0.6	0.6
Linearity	4.7	rectangular	•3	1	1	2.7	2.7
Detection Limit	1.0	rectangular	•3	1	1	0.6	0.6
Readout Electronics	1.0	normal	1	1	1	1.0	1.0
Response Time	0.8	rectangular	•3	1	1	0.5	0.5
Integration Time	1.7	rectangular	•3	1	1	1.0	1.0
RF Ambient Condition	3.0	rectangular	•3	1	1	1.7	1.7
Probe Positioner Mech.	0.4	rectangular	•3	1	1	0.2	0.2
Restriction							
Probe Positioning with respect to Phantom Shell	2.9	rectangular	•3	1	1	1.7	1.7
Extrapolation and Integration	3.7	rectangular	•3	1	1	2.1	2.1
Test Sample Positioning	4.0	normal	1	1	1	4.0	4.0
Device Holder Uncertainty	2.0	normal	1	1	1	2.0	2.0
Drift of Output Power	10.6	rectangular	•3	1	1	6.1	6.1
Phantom and Setup							
Phantom Uncertainty(shape & thickness tolerance)	3.4	rectangular	•3	1	1	2.0	2.0
Liquid Conductivity(target)	5.0	rectangular	•3	0.7	0.5	2.0	1.4
Liquid Conductivity(meas.)	642.2	normal	1	0.7	0.5	449.5	321.1
Liquid Permittivity(target)	5.0	rectangular	•3	0.6	0.5	1.7	1.4
Liquid Permittivity(meas.)	16.3	normal	1	0.6	0.5	9.8	8.2
Combined Uncertainty		RSS				449.7	321.4
Combined Uncertainty (coverage factor=2)		Normal (k=2)				899.5	642.8

SAR Test Report

Operator : Jay
Validation Date : 16-Jun-2005
Measurement Date : 16-Jun-2005
Starting Time : 16-Jun-2005 12:58:17 PM
End Time : 16-Jun-2005 01:10:57 PM
Scanning Time : 760 secs

Product Data

Device Name : Motion Computing
Serial No. : Gemtech Module Aux Antenna
Type : Other
Model : TS01
Frequency : 5800.00 MHz
Max. Transmit Pwr : 0.05 W
Drift Time : 0 min(s)
Length : 200 mm
Width : 170 mm
Depth : 23 mm
Antenna Type : Internal
Power Drift-Start : 0.115 W/kg
Power Drift-Finish: 0.119 W/kg
Power Drift (%) : 3.478

Phantom Data

Name : APREL-Uni
Type : Uni-Phantom
Size (mm) : 280 x 280 x 200
Serial No. : System Default
Location : Center
Description : Uni-Phantom

Tissue Data

Type : BODY
Serial No. : 5800
Frequency : 5800 MHz
Last Calib. Date : 16-Jun-2005
Temperature : 21 °C
Ambient Temp. : 24 °C
Humidity : 61 RH%
Epsilon : 48.52 F/m
Sigma : 6.16 S/m
Density : 1000 kg/cu. m

Probe Data

Name : Probe 215 - RFEL
Model : E020
Type : E-Field Triangle
Serial No. : 215
Last Calib. Date : 10-Jun-2005
Frequency : 5800 MHz
Duty Cycle Factor: 1
Conversion Factor: 2.1
Probe Sensitivity: 1.20 1.20 1.20 $\mu\text{V}/(\text{V}/\text{m})^2$
Compression Point: 95 mV
Offset : 1.56 mm

Measurement Data

Crest Factor : 1
Scan Type : Complete
Tissue Temp. : 21°C
Ambient Temp. : 24°C
Set-up Date : 16-Jun-2005
Set-up Time : 12:54:38 PM
Area Scan : 4x5x1 : Measurement x=10mm, y=10mm, z=4mm
Zoom Scan : 5x5x8 : Measurement x=8mm, y=8mm, z=4mm

Other Data

DUT Position : Touch
Separation : 0
Channel : Mid - 5765

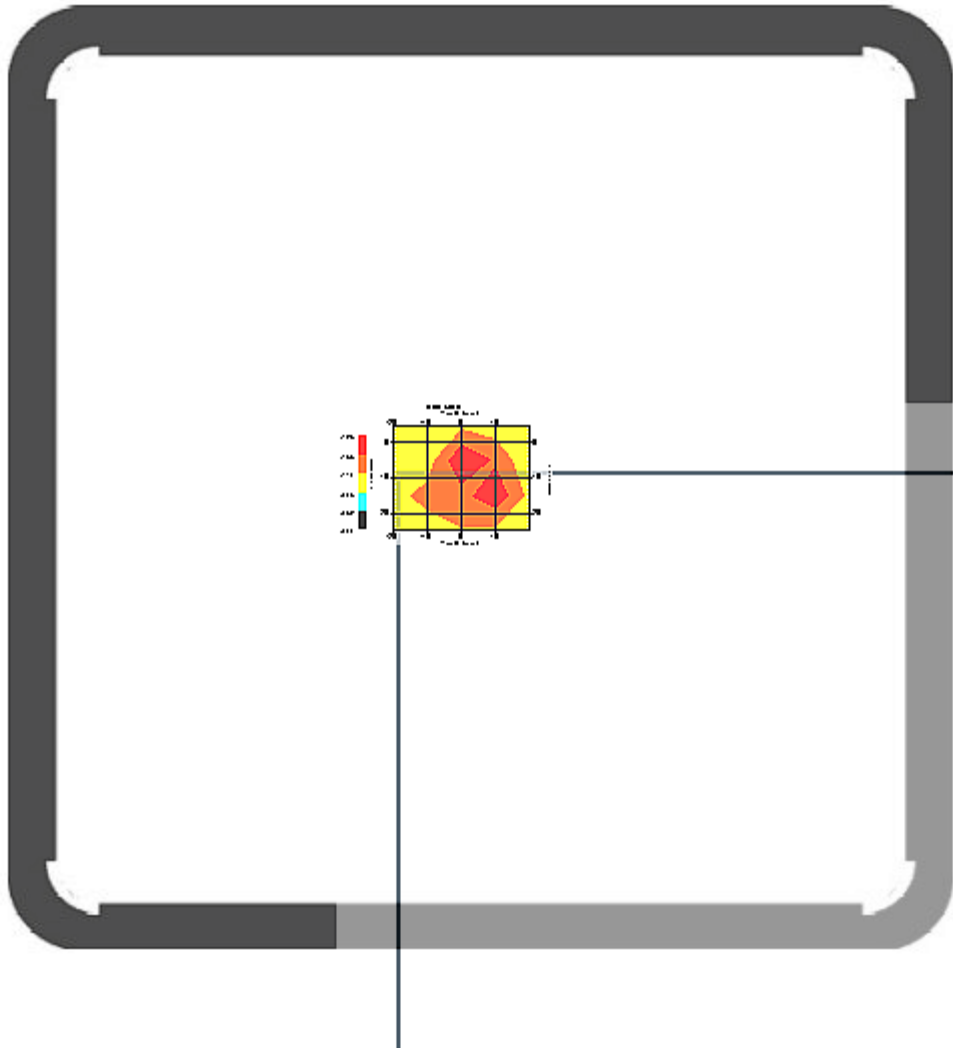

1 gram SAR value : 0.169 W/kg
10 gram SAR value : 0.127 W/kg
Area Scan Peak SAR : 0.193 W/kg
Zoom Scan Peak SAR : 0.410 W/kg

Exposure Assessment Measurement Uncertainty

Source of Uncertainty	Tolerance Value	Probability Distribution	Divisor	c_i^{-1} (1-g)	c_i^{-1} (10-g)	Standard Uncertainty (1-g) %	Standard Uncertainty (10-g) %
Measurement System							
Probe Calibration	3.5	normal	1	1	1	3.5	3.5
Axial Isotropy	3.7	rectangular	•3	$(1-cp)^{1/2}$	$(1-cp)^{1/2}$	1.5	1.5
Hemispherical Isotropy	10.9	rectangular	•3	•cp	•cp	4.4	4.4
Boundary Effect	1.0	rectangular	•3	1	1	0.6	0.6
Linearity	4.7	rectangular	•3	1	1	2.7	2.7
Detection Limit	1.0	rectangular	•3	1	1	0.6	0.6
Readout Electronics	1.0	normal	1	1	1	1.0	1.0
Response Time	0.8	rectangular	•3	1	1	0.5	0.5
Integration Time	1.7	rectangular	•3	1	1	1.0	1.0
RF Ambient Condition	3.0	rectangular	•3	1	1	1.7	1.7
Probe Positioner Mech.	0.4	rectangular	•3	1	1	0.2	0.2
Restriction							
Probe Positioning with respect to Phantom Shell	2.9	rectangular	•3	1	1	1.7	1.7
Extrapolation and Integration	3.7	rectangular	•3	1	1	2.1	2.1
Test Sample Positioning	4.0	normal	1	1	1	4.0	4.0
Device Holder Uncertainty	2.0	normal	1	1	1	2.0	2.0
Drift of Output Power	13.9	rectangular	•3	1	1	8.0	8.0
Phantom and Setup							
Phantom Uncertainty(shape & thickness tolerance)	3.4	rectangular	•3	1	1	2.0	2.0
Liquid Conductivity(target)	5.0	rectangular	•3	0.7	0.5	2.0	1.4
Liquid Conductivity(meas.)	642.2	normal	1	0.7	0.5	449.5	321.1
Liquid Permittivity(target)	5.0	rectangular	•3	0.6	0.5	1.7	1.4
Liquid Permittivity(meas.)	16.3	normal	1	0.6	0.5	9.8	8.2
Combined Uncertainty		RSS				449.8	321.4
Combined Uncertainty (coverage factor=2)		Normal (k=2)				899.5	642.9

SAR Test Report

Operator : Jay
Validation Date : 16-Jun-2005
Measurement Date : 16-Jun-2005
Starting Time : 16-Jun-2005 12:36:46 PM
End Time : 16-Jun-2005 12:49:24 PM
Scanning Time : 758 secs

Product Data

Device Name : Motion Computing
Serial No. : Intel Module Main Antenna w/BT
Type : Other
Model : TS01
Frequency : 5800.00 MHz
Max. Transmit Pwr : 0.05 W
Drift Time : 0 min(s)
Length : 200 mm
Width : 170 mm
Depth : 23 mm
Antenna Type : Internal
Power Drift-Start : 0.202 W/kg
Power Drift-Finish: 0.207 W/kg
Power Drift (%) : 2.475

Phantom Data

Name : APREL-Uni
Type : Uni-Phantom
Size (mm) : 280 x 280 x 200
Serial No. : System Default
Location : Center
Description : Uni-Phantom

Tissue Data

Type : BODY
Serial No. : 5800
Frequency : 5800 MHz
Last Calib. Date : 16-Jun-2005
Temperature : 21 °C
Ambient Temp. : 24 °C
Humidity : 61 RH%
Epsilon : 48.52 F/m
Sigma : 6.16 S/m
Density : 1000 kg/cu. m

Probe Data

Name : Probe 215 - RFEL
Model : E020
Type : E-Field Triangle
Serial No. : 215
Last Calib. Date : 10-Jun-2005
Frequency : 5800 MHz
Duty Cycle Factor: 1
Conversion Factor: 2.1
Probe Sensitivity: 1.20 1.20 1.20 $\mu\text{V}/(\text{V}/\text{m})^2$
Compression Point: 95 mV
Offset : 1.56 mm

Measurement Data

Crest Factor : 1
Scan Type : Complete
Tissue Temp. : 21°C
Ambient Temp. : 24°C
Set-up Date : 16-Jun-2005
Set-up Time : 12:17:25 PM
Area Scan : 4x5x1 : Measurement x=10mm, y=10mm, z=4mm
Zoom Scan : 5x5x8 : Measurement x=8mm, y=8mm, z=4mm

Other Data

DUT Position : Touch
Separation : 0
Channel : Mid - 5765

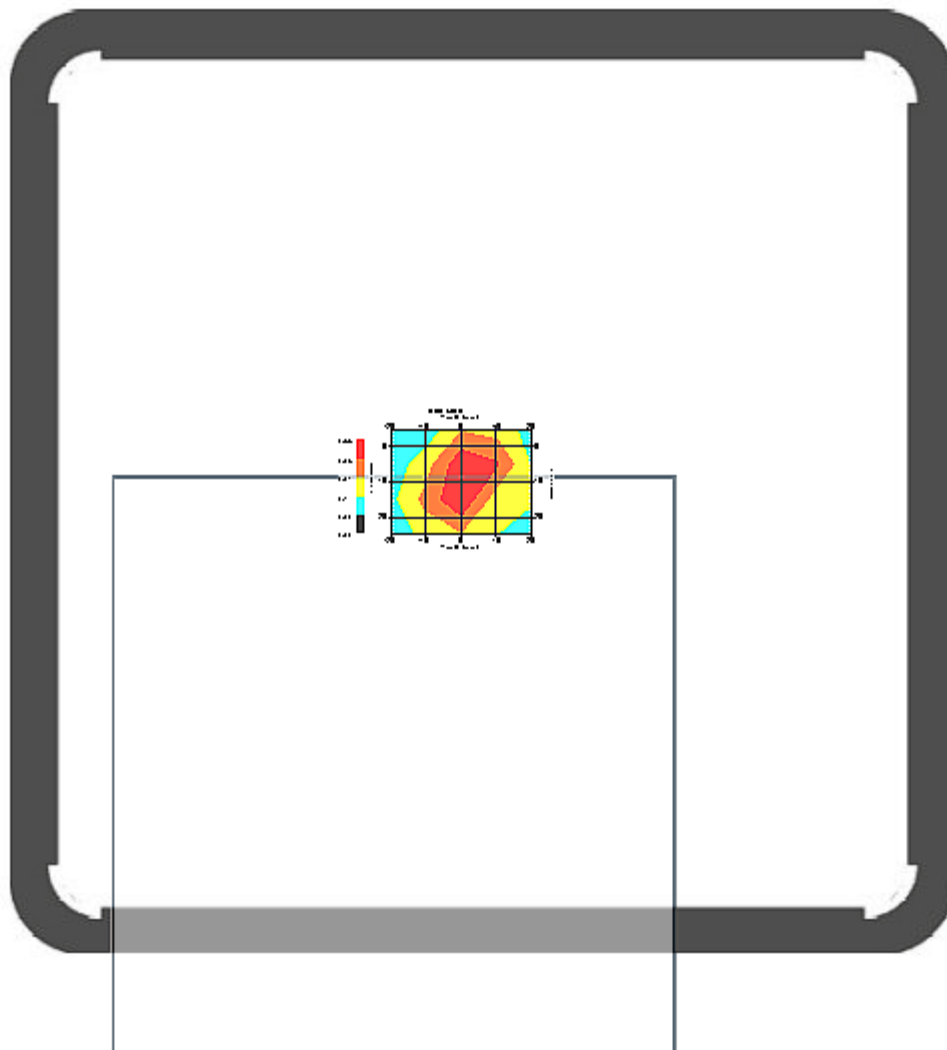

1 gram SAR value : 0.470 W/kg
10 gram SAR value : 0.208 W/kg
Area Scan Peak SAR : 0.348 W/kg
Zoom Scan Peak SAR : 1.391 W/kg

Exposure Assessment Measurement Uncertainty

Source of Uncertainty	Tolerance Value	Probability Distribution	Divisor	c_i^{-1} (1-g)	c_i^{-1} (10-g)	Standard Uncertainty (1-g) %	Standard Uncertainty (10-g) %
Measurement System							
Probe Calibration	3.5	normal	1	1	1	3.5	3.5
Axial Isotropy	3.7	rectangular	•3	$(1-cp)^{1/2}$	$(1-cp)^{1/2}$	1.5	1.5
Hemispherical Isotropy	10.9	rectangular	•3	•cp	•cp	4.4	4.4
Boundary Effect	1.0	rectangular	•3	1	1	0.6	0.6
Linearity	4.7	rectangular	•3	1	1	2.7	2.7
Detection Limit	1.0	rectangular	•3	1	1	0.6	0.6
Readout Electronics	1.0	normal	1	1	1	1.0	1.0
Response Time	0.8	rectangular	•3	1	1	0.5	0.5
Integration Time	1.7	rectangular	•3	1	1	1.0	1.0
RF Ambient Condition	3.0	rectangular	•3	1	1	1.7	1.7
Probe Positioner Mech.	0.4	rectangular	•3	1	1	0.2	0.2
Restriction							
Probe Positioning with respect to Phantom Shell	2.9	rectangular	•3	1	1	1.7	1.7
Extrapolation and Integration	3.7	rectangular	•3	1	1	2.1	2.1
Test Sample Positioning	4.0	normal	1	1	1	4.0	4.0
Device Holder Uncertainty	2.0	normal	1	1	1	2.0	2.0
Drift of Output Power	42.3	rectangular	•3	1	1	24.4	24.4
Phantom and Setup							
Phantom Uncertainty(shape & thickness tolerance)	3.4	rectangular	•3	1	1	2.0	2.0
Liquid Conductivity(target)	5.0	rectangular	•3	0.7	0.5	2.0	1.4
Liquid Conductivity(meas.)	642.2	normal	1	0.7	0.5	449.5	321.1
Liquid Permittivity(target)	5.0	rectangular	•3	0.6	0.5	1.7	1.4
Liquid Permittivity(meas.)	16.3	normal	1	0.6	0.5	9.8	8.2
Combined Uncertainty		RSS				450.4	322.3
Combined Uncertainty (coverage factor=2)		Normal (k=2)				900.7	644.5

SAR-Z Axis at Hotspot x:7.20 y:-0.50

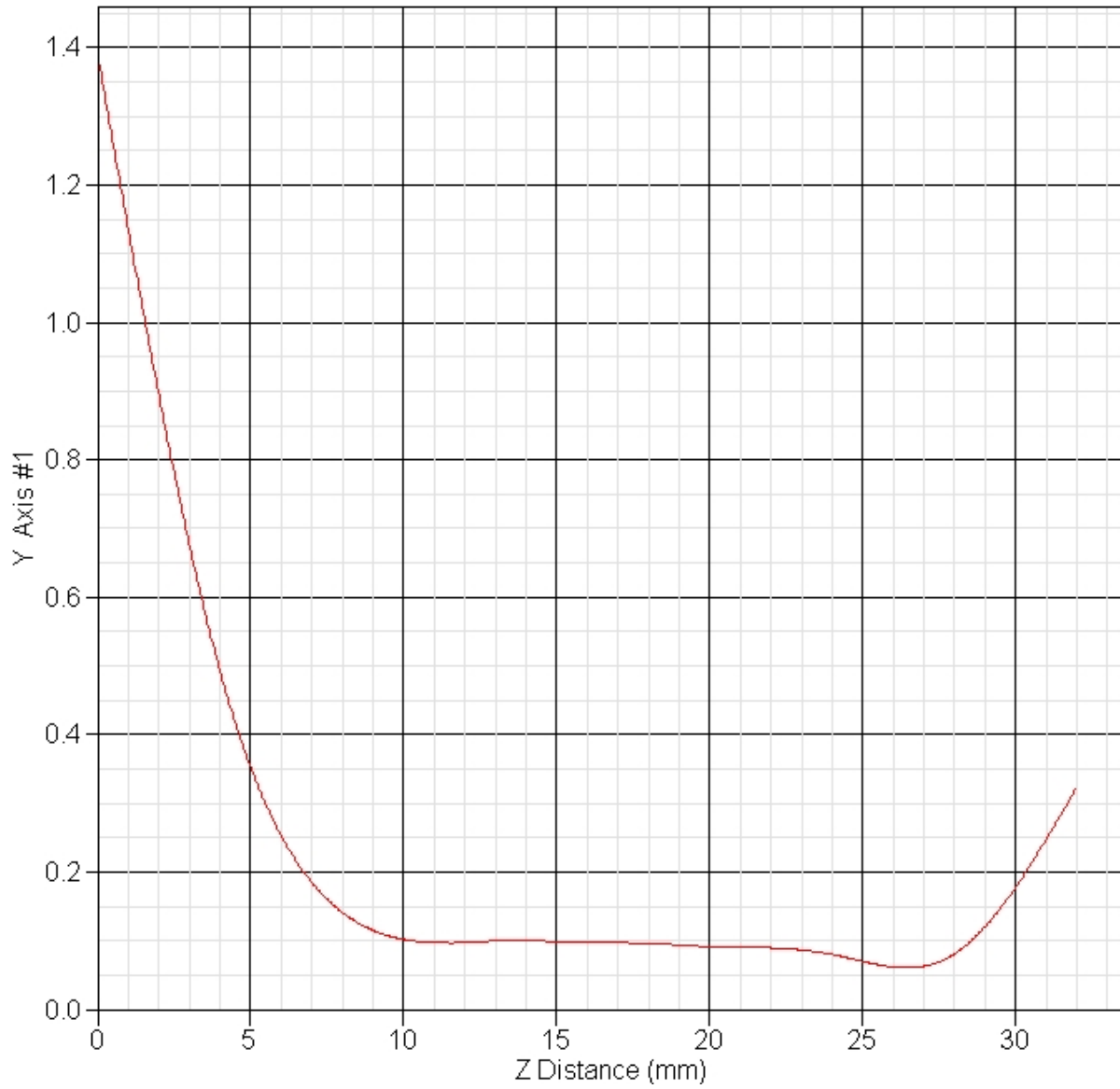

SAR Test Report

Operator : Jay
Validation Date : 17-Jun-2005
Measurement Date : 17-Jun-2005
Starting Time : 17-Jun-2005 01:00:48 PM
End Time : 17-Jun-2005 01:13:53 PM
Scanning Time : 785 secs

Product Data

Device Name : Motion Computing
Serial No. : Intel Module Main Antenna
Type : Other
Model : TS01
Frequency : 2450.00 MHz
Max. Transmit Pwr : 0.05 W
Drift Time : 0 min(s)
Length : 200 mm
Width : 170 mm
Depth : 23 mm
Antenna Type : Internal
Power Drift-Start : 0.100 W/kg
Power Drift-Finish: 0.098 W/kg
Power Drift (%) : -2.025

Phantom Data

Name : APREL-Uni
Type : Uni-Phantom
Size (mm) : 280 x 280 x 200
Serial No. : System Default
Location : Center
Description : Uni-Phantom

Tissue Data

Type : BODY
Serial No. : 2450
Frequency : 2450 MHz
Last Calib. Date : 17-Jun-2005
Temperature : 21 °C
Ambient Temp. : 23 °C
Humidity : 51 RH%
Epsilon : 52.21 F/m
Sigma : 1.98 S/m
Density : 1000 kg/cu. m

Probe Data

Name : Probe 215 - RFEL
Model : E020
Type : E-Field Triangle
Serial No. : 215
Last Calib. Date : 10-Jun-2005
Frequency : 2450 MHz
Duty Cycle Factor: 1
Conversion Factor: 3.6
Probe Sensitivity: 1.20 1.20 1.20 $\mu\text{V}/(\text{V}/\text{m})^2$
Compression Point: 95 mV
Offset : 1.56 mm

Measurement Data

Crest Factor : 1
Scan Type : Complete
Tissue Temp. : 21°C
Ambient Temp. : 24°C
Set-up Date : 17-Jun-2005
Set-up Time : 1:00:39 PM
Area Scan : 4x5x1 : Measurement x=10mm, y=10mm, z=4mm
Zoom Scan : 5x5x8 : Measurement x=8mm, y=8mm, z=4mm

Other Data

DUT Position : Touch
Separation : 0
Channel : Mid - 2437

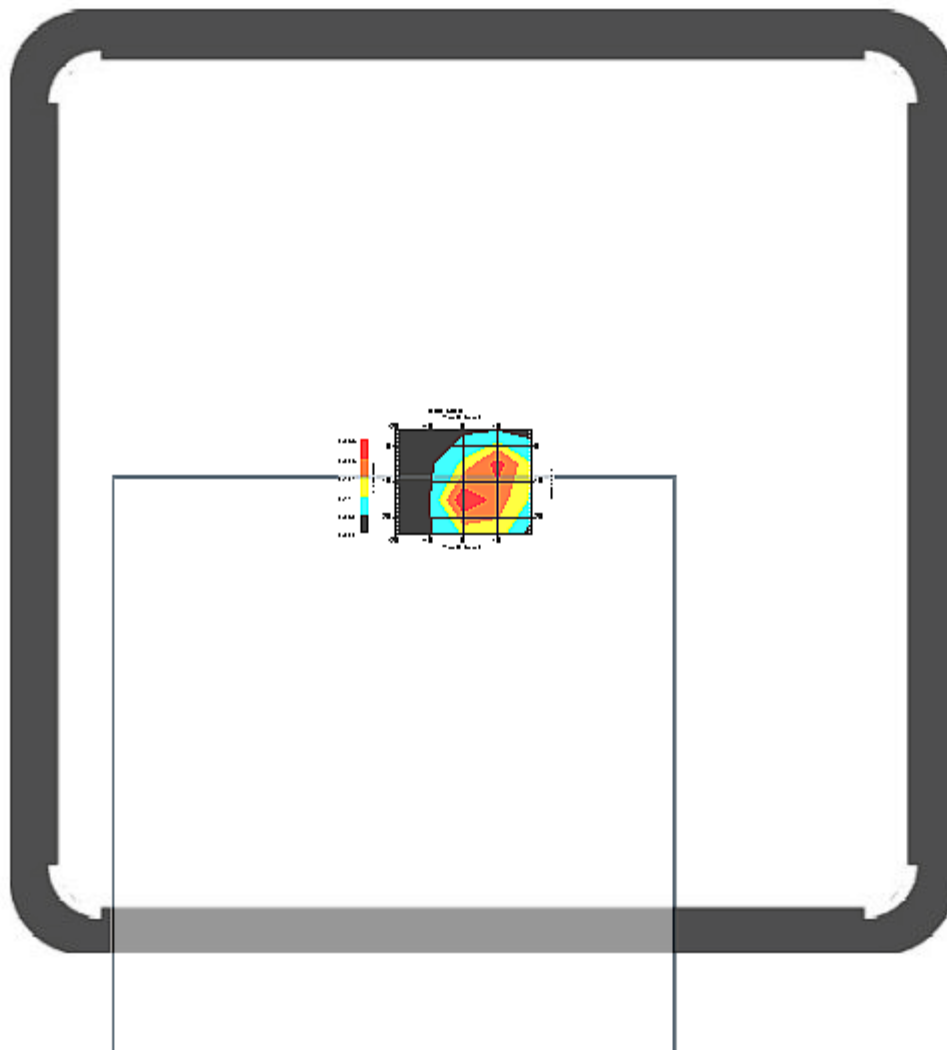

1 gram SAR value : 0.262 W/kg
10 gram SAR value : 0.109 W/kg
Area Scan Peak SAR : 0.283 W/kg
Zoom Scan Peak SAR : 0.590 W/kg

Exposure Assessment Measurement Uncertainty

Source of Uncertainty	Tolerance Value	Probability Distribution	Divisor	c_i^{-1} (1-g)	c_i^{-1} (10-g)	Standard Uncertainty (1-g) %	Standard Uncertainty (10-g) %
Measurement System							
Probe Calibration	3.5	normal	1	1	1	3.5	3.5
Axial Isotropy	3.7	rectangular	•3	$(1-cp)^{1/2}$	$(1-cp)^{1/2}$	1.5	1.5
Hemispherical Isotropy	10.9	rectangular	•3	•cp	•cp	4.4	4.4
Boundary Effect	1.0	rectangular	•3	1	1	0.6	0.6
Linearity	4.7	rectangular	•3	1	1	2.7	2.7
Detection Limit	1.0	rectangular	•3	1	1	0.6	0.6
Readout Electronics	1.0	normal	1	1	1	1.0	1.0
Response Time	0.8	rectangular	•3	1	1	0.5	0.5
Integration Time	1.7	rectangular	•3	1	1	1.0	1.0
RF Ambient Condition	3.0	rectangular	•3	1	1	1.7	1.7
Probe Positioner Mech.	0.4	rectangular	•3	1	1	0.2	0.2
Restriction							
Probe Positioning with respect to Phantom Shell	2.9	rectangular	•3	1	1	1.7	1.7
Extrapolation and Integration	3.7	rectangular	•3	1	1	2.1	2.1
Test Sample Positioning	4.0	normal	1	1	1	4.0	4.0
Device Holder Uncertainty	2.0	normal	1	1	1	2.0	2.0
Drift of Output Power	32.4	rectangular	•3	1	1	18.7	18.7
Phantom and Setup							
Phantom Uncertainty(shape & thickness tolerance)	3.4	rectangular	•3	1	1	2.0	2.0
Liquid Conductivity(target)	5.0	rectangular	•3	0.7	0.5	2.0	1.4
Liquid Conductivity(meas.)	138.6	normal	1	0.7	0.5	97.0	69.3
Liquid Permittivity(target)	5.0	rectangular	•3	0.6	0.5	1.7	1.4
Liquid Permittivity(meas.)	10.0	normal	1	0.6	0.5	6.0	5.0
Combined Uncertainty		RSS				99.4	72.5
Combined Uncertainty (coverage factor=2)		Normal (k=2)				198.8	145.0

SAR Test Report

Operator : Jay
Validation Date : 17-Jun-2005
Measurement Date : 17-Jun-2005
Starting Time : 17-Jun-2005 02:13:35 PM
End Time : 17-Jun-2005 02:26:23 PM
Scanning Time : 768 secs

Product Data

Device Name : Motion Computing
Serial No. : Gemtech Module Main Antenna
Type : Other
Model : TS01
Frequency : 2450.00 MHz
Max. Transmit Pwr : 0.05 W
Drift Time : 0 min(s)
Length : 200 mm
Width : 170 mm
Depth : 23 mm
Antenna Type : Internal
Power Drift-Start : 0.392 W/kg
Power Drift-Finish: 0.373 W/kg
Power Drift (%) : -4.847

Phantom Data

Name : APREL-Uni
Type : Uni-Phantom
Size (mm) : 280 x 280 x 200
Serial No. : System Default
Location : Center
Description : Uni-Phantom

Tissue Data

Type : BODY
Serial No. : 2450
Frequency : 2450 MHz
Last Calib. Date : 17-Jun-2005
Temperature : 21 °C
Ambient Temp. : 23 °C
Humidity : 51 RH%
Epsilon : 52.21 F/m
Sigma : 1.98 S/m
Density : 1000 kg/cu. m

Probe Data

Name : Probe 215 - RFEL
Model : E020
Type : E-Field Triangle
Serial No. : 215
Last Calib. Date : 10-Jun-2005
Frequency : 2450 MHz
Duty Cycle Factor: 1
Conversion Factor: 3.6
Probe Sensitivity: 1.20 1.20 1.20 $\mu\text{V}/(\text{V}/\text{m})^2$
Compression Point: 95 mV
Offset : 1.56 mm

Measurement Data

Crest Factor : 1
Scan Type : Complete
Tissue Temp. : 21°C
Ambient Temp. : 24°C
Set-up Date : 17-Jun-2005
Set-up Time : 1:57:46 PM
Area Scan : 4x5x1 : Measurement x=10mm, y=10mm, z=4mm
Zoom Scan : 5x5x8 : Measurement x=8mm, y=8mm, z=4mm

Other Data

DUT Position : Touch
Separation : 0
Channel : Mid - 2437

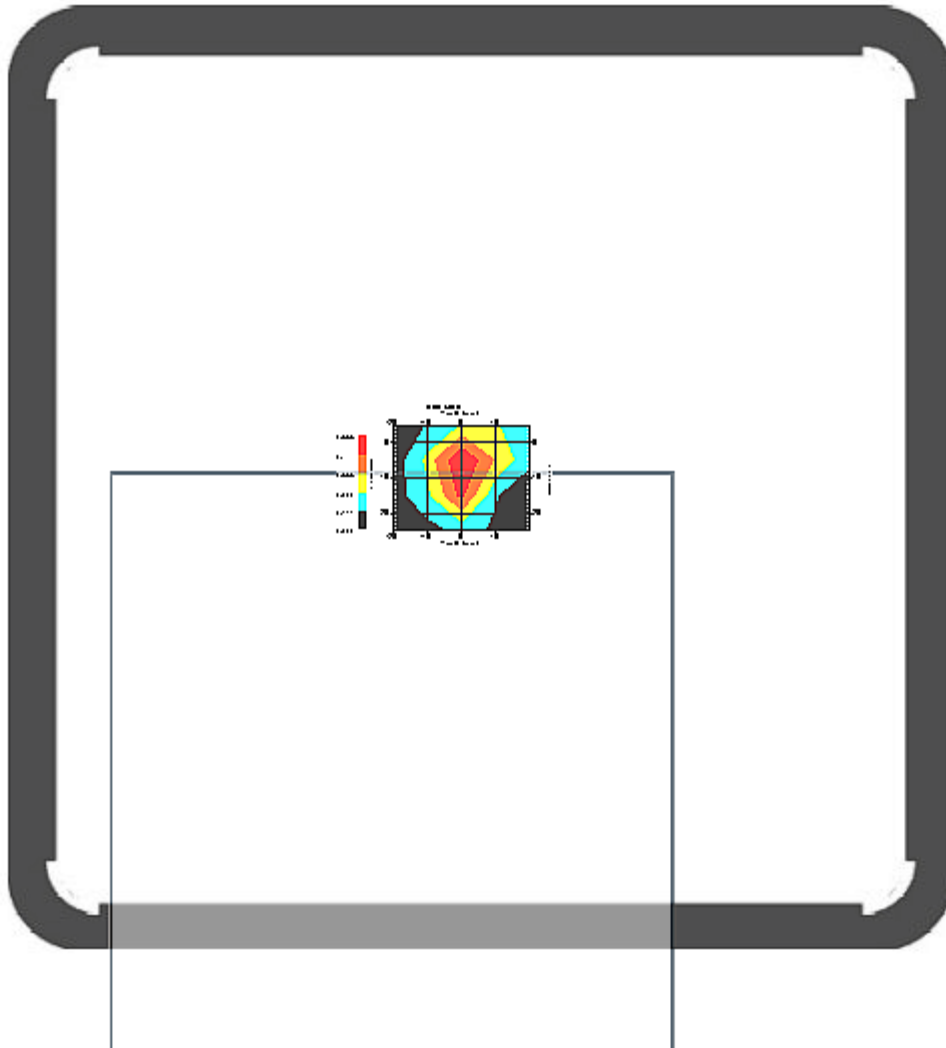

1 gram SAR value : 0.401 W/kg
10 gram SAR value : 0.167 W/kg
Area Scan Peak SAR : 0.554 W/kg
Zoom Scan Peak SAR : 0.910 W/kg

Exposure Assessment Measurement Uncertainty

Source of Uncertainty	Tolerance Value	Probability Distribution	Divisor	c_i^{-1} (1-g)	c_i^{-1} (10-g)	Standard Uncertainty (1-g) %	Standard Uncertainty (10-g) %
Measurement System							
Probe Calibration	3.5	normal	1	1	1	3.5	3.5
Axial Isotropy	3.7	rectangular	•3	$(1-cp)^{1/2}$	$(1-cp)^{1/2}$	1.5	1.5
Hemispherical Isotropy	10.9	rectangular	•3	•cp	•cp	4.4	4.4
Boundary Effect	1.0	rectangular	•3	1	1	0.6	0.6
Linearity	4.7	rectangular	•3	1	1	2.7	2.7
Detection Limit	1.0	rectangular	•3	1	1	0.6	0.6
Readout Electronics	1.0	normal	1	1	1	1.0	1.0
Response Time	0.8	rectangular	•3	1	1	0.5	0.5
Integration Time	1.7	rectangular	•3	1	1	1.0	1.0
RF Ambient Condition	3.0	rectangular	•3	1	1	1.7	1.7
Probe Positioner Mech.	0.4	rectangular	•3	1	1	0.2	0.2
Restriction							
Probe Positioning with respect to Phantom Shell	2.9	rectangular	•3	1	1	1.7	1.7
Extrapolation and Integration	3.7	rectangular	•3	1	1	2.1	2.1
Test Sample Positioning	4.0	normal	1	1	1	4.0	4.0
Device Holder Uncertainty	2.0	normal	1	1	1	2.0	2.0
Drift of Output Power	9.8	rectangular	•3	1	1	5.7	5.7
Phantom and Setup							
Phantom Uncertainty(shape & thickness tolerance)	3.4	rectangular	•3	1	1	2.0	2.0
Liquid Conductivity(target)	5.0	rectangular	•3	0.7	0.5	2.0	1.4
Liquid Conductivity(meas.)	138.6	normal	1	0.7	0.5	97.0	69.3
Liquid Permittivity(target)	5.0	rectangular	•3	0.6	0.5	1.7	1.4
Liquid Permittivity(meas.)	10.0	normal	1	0.6	0.5	6.0	5.0
Combined Uncertainty		RSS				97.8	70.3
Combined Uncertainty (coverage factor=2)		Normal (k=2)				195.6	140.6

SAR Test Report

Operator : Jay
Validation Date : 17-Jun-2005
Measurement Date : 17-Jun-2005
Starting Time : 17-Jun-2005 12:33:51 PM
End Time : 17-Jun-2005 12:47:03 PM
Scanning Time : 792 secs

Product Data

Device Name : Motion Computing
Serial No. : Intel Module Aux Antenna
Type : Other
Model : TS01
Frequency : 2450.00 MHz
Max. Transmit Pwr : 0.05 W
Drift Time : 0 min(s)
Length : 200 mm
Width : 170 mm
Depth : 23 mm
Antenna Type : Internal
Power Drift-Start : 0.100 W/kg
Power Drift-Finish: 0.096 W/kg
Power Drift (%) : -4.270

Phantom Data

Name : APREL-Uni
Type : Uni-Phantom
Size (mm) : 280 x 280 x 200
Serial No. : System Default
Location : Center
Description : Uni-Phantom

Tissue Data

Type : BODY
Serial No. : 2450
Frequency : 2450 MHz
Last Calib. Date : 17-Jun-2005
Temperature : 21 °C
Ambient Temp. : 23 °C
Humidity : 51 RH%
Epsilon : 52.21 F/m
Sigma : 1.98 S/m
Density : 1000 kg/cu. m

Probe Data

Name : Probe 215 - RFEL
Model : E020
Type : E-Field Triangle
Serial No. : 215
Last Calib. Date : 10-Jun-2005
Frequency : 2450 MHz
Duty Cycle Factor: 1
Conversion Factor: 3.6
Probe Sensitivity: 1.20 1.20 1.20 $\mu\text{V}/(\text{V}/\text{m})^2$
Compression Point: 95 mV
Offset : 1.56 mm

Measurement Data

Crest Factor : 1
Scan Type : Complete
Tissue Temp. : 21°C
Ambient Temp. : 23°C
Set-up Date : 17-Jun-2005
Set-up Time : 12:28:23 PM
Area Scan : 4x5x1 : Measurement x=10mm, y=10mm, z=4mm
Zoom Scan : 5x5x8 : Measurement x=8mm, y=8mm, z=4mm

Other Data

DUT Position : Touch
Separation : 0
Channel : Mid - 2437

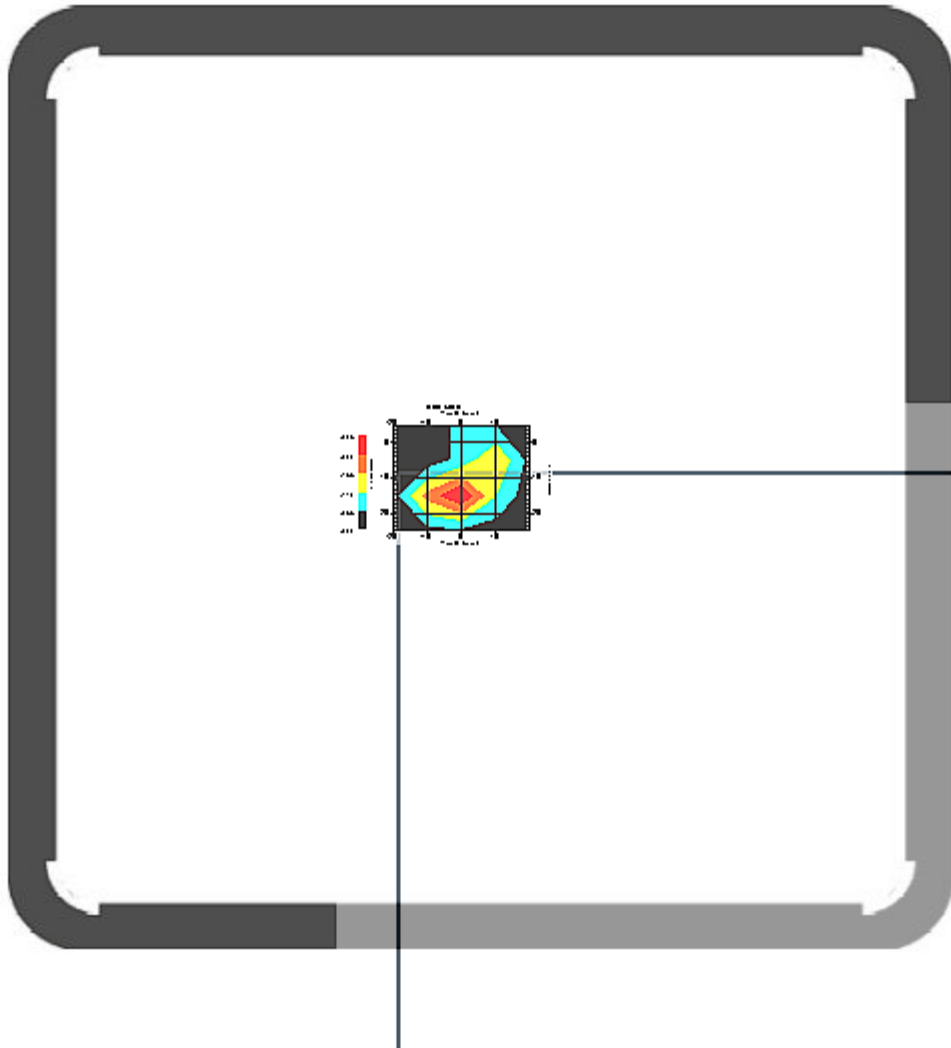

1 gram SAR value : 0.232 W/kg
10 gram SAR value : 0.074 W/kg
Area Scan Peak SAR : 0.273 W/kg
Zoom Scan Peak SAR : 0.730 W/kg

Exposure Assessment Measurement Uncertainty

Source of Uncertainty	Tolerance Value	Probability Distribution	Divisor	c_i^{-1} (1-g)	c_i^{-1} (10-g)	Standard Uncertainty (1-g) %	Standard Uncertainty (10-g) %
Measurement System							
Probe Calibration	3.5	normal	1	1	1	3.5	3.5
Axial Isotropy	3.7	rectangular	•3	$(1-cp)^{1/2}$	$(1-cp)^{1/2}$	1.5	1.5
Hemispherical Isotropy	10.9	rectangular	•3	•cp	•cp	4.4	4.4
Boundary Effect	1.0	rectangular	•3	1	1	0.6	0.6
Linearity	4.7	rectangular	•3	1	1	2.7	2.7
Detection Limit	1.0	rectangular	•3	1	1	0.6	0.6
Readout Electronics	1.0	normal	1	1	1	1.0	1.0
Response Time	0.8	rectangular	•3	1	1	0.5	0.5
Integration Time	1.7	rectangular	•3	1	1	1.0	1.0
RF Ambient Condition	3.0	rectangular	•3	1	1	1.7	1.7
Probe Positioner Mech.	0.4	rectangular	•3	1	1	0.2	0.2
Restriction							
Probe Positioning with respect to Phantom Shell	2.9	rectangular	•3	1	1	1.7	1.7
Extrapolation and Integration	3.7	rectangular	•3	1	1	2.1	2.1
Test Sample Positioning	4.0	normal	1	1	1	4.0	4.0
Device Holder Uncertainty	2.0	normal	1	1	1	2.0	2.0
Drift of Output Power	40.3	rectangular	•3	1	1	23.2	23.2
Phantom and Setup							
Phantom Uncertainty(shape & thickness tolerance)	3.4	rectangular	•3	1	1	2.0	2.0
Liquid Conductivity(target)	5.0	rectangular	•3	0.7	0.5	2.0	1.4
Liquid Conductivity(meas.)	138.6	normal	1	0.7	0.5	97.0	69.3
Liquid Permittivity(target)	5.0	rectangular	•3	0.6	0.5	1.7	1.4
Liquid Permittivity(meas.)	10.0	normal	1	0.6	0.5	6.0	5.0
Combined Uncertainty		RSS				100.3	73.8
Combined Uncertainty (coverage factor=2)		Normal (k=2)				200.7	147.6

SAR Test Report

Operator : Jay
Validation Date : 17-Jun-2005
Measurement Date : 17-Jun-2005
Starting Time : 17-Jun-2005 01:41:45 PM
End Time : 17-Jun-2005 01:54:48 PM
Scanning Time : 783 secs

Product Data

Device Name : Motion Computing
Serial No. : Gemtech Module Aux Antenna
Type : Other
Model : TS01
Frequency : 2450.00 MHz
Max. Transmit Pwr : 0.05 W
Drift Time : 0 min(s)
Length : 200 mm
Width : 170 mm
Depth : 23 mm
Antenna Type : Internal
Power Drift-Start : 0.147 W/kg
Power Drift-Finish: 0.139 W/kg
Power Drift (%) : -5.442

Phantom Data

Name : APREL-Uni
Type : Uni-Phantom
Size (mm) : 280 x 280 x 200
Serial No. : System Default
Location : Center
Description : Uni-Phantom

Tissue Data

Type : BODY
Serial No. : 2450
Frequency : 2450 MHz
Last Calib. Date : 17-Jun-2005
Temperature : 21 °C
Ambient Temp. : 23 °C
Humidity : 51 RH%
Epsilon : 52.21 F/m
Sigma : 1.98 S/m
Density : 1000 kg/cu. m

Probe Data

Name : Probe 215 - RFEL
Model : E020
Type : E-Field Triangle
Serial No. : 215
Last Calib. Date : 10-Jun-2005
Frequency : 2450 MHz
Duty Cycle Factor: 1
Conversion Factor: 3.6
Probe Sensitivity: 1.20 1.20 1.20 $\mu\text{V}/(\text{V/m})^2$
Compression Point: 95 mV
Offset : 1.56 mm

Measurement Data

Crest Factor : 1
Scan Type : Complete
Tissue Temp. : 21°C
Ambient Temp. : 24°C
Set-up Date : 17-Jun-2005
Set-up Time : 1:35:52 PM
Area Scan : 4x5x1 : Measurement x=10mm, y=10mm, z=4mm
Zoom Scan : 5x5x8 : Measurement x=8mm, y=8mm, z=4mm

Other Data

DUT Position : Touch
Separation : 0
Channel : Mid - 2437

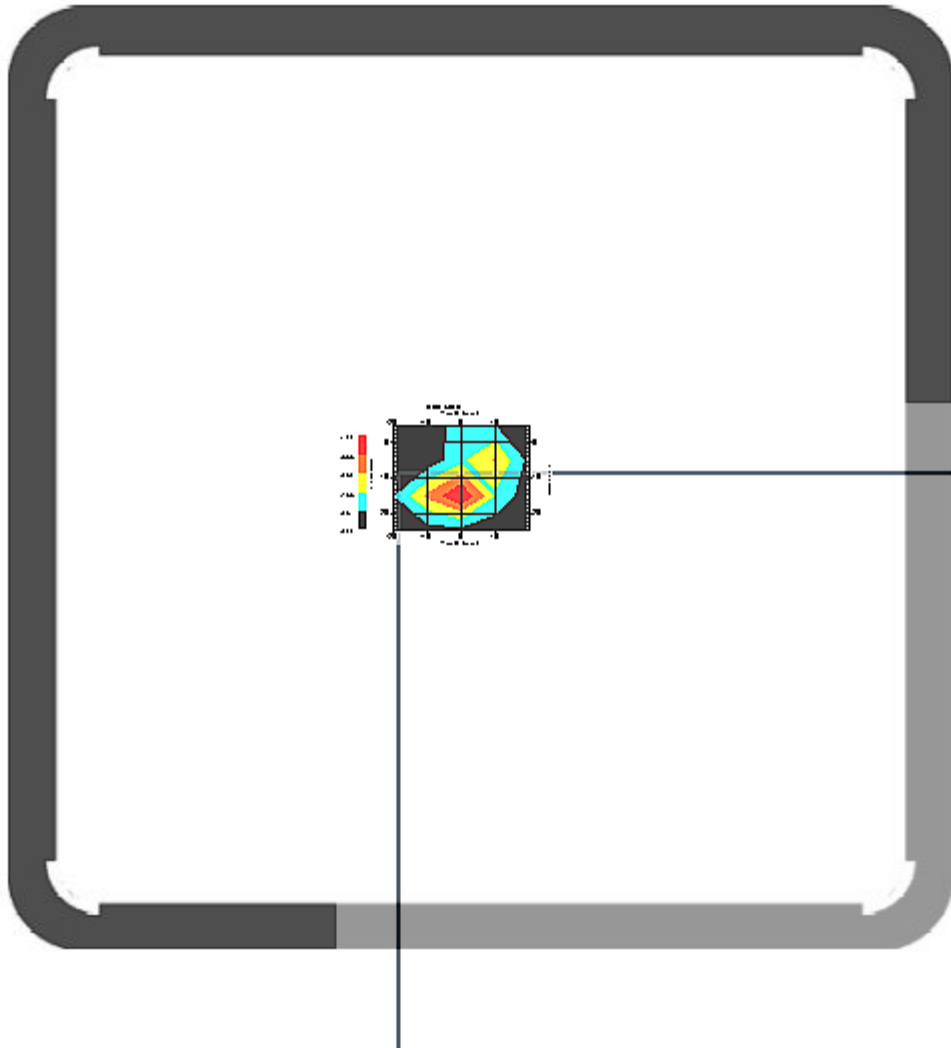

1 gram SAR value : 0.239 W/kg
10 gram SAR value : 0.084 W/kg
Area Scan Peak SAR : 0.419 W/kg
Zoom Scan Peak SAR : 0.690 W/kg

Exposure Assessment Measurement Uncertainty

Source of Uncertainty	Tolerance Value	Probability Distribution	Divisor	c_i^{-1} (1-g)	c_i^{-1} (10-g)	Standard Uncertainty (1-g) %	Standard Uncertainty (10-g) %
Measurement System							
Probe Calibration	3.5	normal	1	1	1	3.5	3.5
Axial Isotropy	3.7	rectangular	•3	$(1-cp)^{1/2}$	$(1-cp)^{1/2}$	1.5	1.5
Hemispherical Isotropy	10.9	rectangular	•3	•cp	•cp	4.4	4.4
Boundary Effect	1.0	rectangular	•3	1	1	0.6	0.6
Linearity	4.7	rectangular	•3	1	1	2.7	2.7
Detection Limit	1.0	rectangular	•3	1	1	0.6	0.6
Readout Electronics	1.0	normal	1	1	1	1.0	1.0
Response Time	0.8	rectangular	•3	1	1	0.5	0.5
Integration Time	1.7	rectangular	•3	1	1	1.0	1.0
RF Ambient Condition	3.0	rectangular	•3	1	1	1.7	1.7
Probe Positioner Mech.	0.4	rectangular	•3	1	1	0.2	0.2
Restriction							
Probe Positioning with respect to Phantom Shell	2.9	rectangular	•3	1	1	1.7	1.7
Extrapolation and Integration	3.7	rectangular	•3	1	1	2.1	2.1
Test Sample Positioning	4.0	normal	1	1	1	4.0	4.0
Device Holder Uncertainty	2.0	normal	1	1	1	2.0	2.0
Drift of Output Power	39.2	rectangular	•3	1	1	22.7	22.7
Phantom and Setup							
Phantom Uncertainty(shape & thickness tolerance)	3.4	rectangular	•3	1	1	2.0	2.0
Liquid Conductivity(target)	5.0	rectangular	•3	0.7	0.5	2.0	1.4
Liquid Conductivity(meas.)	138.6	normal	1	0.7	0.5	97.0	69.3
Liquid Permittivity(target)	5.0	rectangular	•3	0.6	0.5	1.7	1.4
Liquid Permittivity(meas.)	10.0	normal	1	0.6	0.5	6.0	5.0
Combined Uncertainty		RSS				100.2	73.7
Combined Uncertainty (coverage factor=2)		Normal (k=2)				200.5	147.3

SAR Test Report

Operator : Jay
Validation Date : 17-Jun-2005
Measurement Date : 17-Jun-2005
Starting Time : 17-Jun-2005 02:30:21 PM
End Time : 17-Jun-2005 02:43:04 PM
Scanning Time : 763 secs

Product Data

Device Name : Motion Computing
Serial No. : Gemtech Module Main Antenna
Type : Other
Model : TS01
Frequency : 2450.00 MHz
Max. Transmit Pwr : 0.05 W
Drift Time : 0 min(s)
Length : 200 mm
Width : 170 mm
Depth : 23 mm
Antenna Type : Internal
Power Drift-Start : 0.267 W/kg
Power Drift-Finish: 0.278 W/kg
Power Drift (%) : 4.120

Phantom Data

Name : APREL-Uni
Type : Uni-Phantom
Size (mm) : 280 x 280 x 200
Serial No. : System Default
Location : Center
Description : Uni-Phantom

Tissue Data

Type : BODY
Serial No. : 2450
Frequency : 2450 MHz
Last Calib. Date : 17-Jun-2005
Temperature : 21 °C
Ambient Temp. : 23 °C
Humidity : 51 RH%
Epsilon : 52.21 F/m
Sigma : 1.98 S/m
Density : 1000 kg/cu. m

Probe Data

Name : Probe 215 - RFEL
Model : E020
Type : E-Field Triangle
Serial No. : 215
Last Calib. Date : 10-Jun-2005
Frequency : 2450 MHz
Duty Cycle Factor: 1
Conversion Factor: 3.6
Probe Sensitivity: 1.20 1.20 1.20 $\mu\text{V}/(\text{V}/\text{m})^2$
Compression Point: 95 mV
Offset : 1.56 mm

Measurement Data

Crest Factor : 1
Scan Type : Complete
Tissue Temp. : 21°C
Ambient Temp. : 24°C
Set-up Date : 17-Jun-2005
Set-up Time : 1:57:46 PM
Area Scan : 4x5x1 : Measurement x=10mm, y=10mm, z=4mm
Zoom Scan : 5x5x8 : Measurement x=8mm, y=8mm, z=4mm

Other Data

DUT Position : Touch
Separation : 0
Channel : Mid - 2437

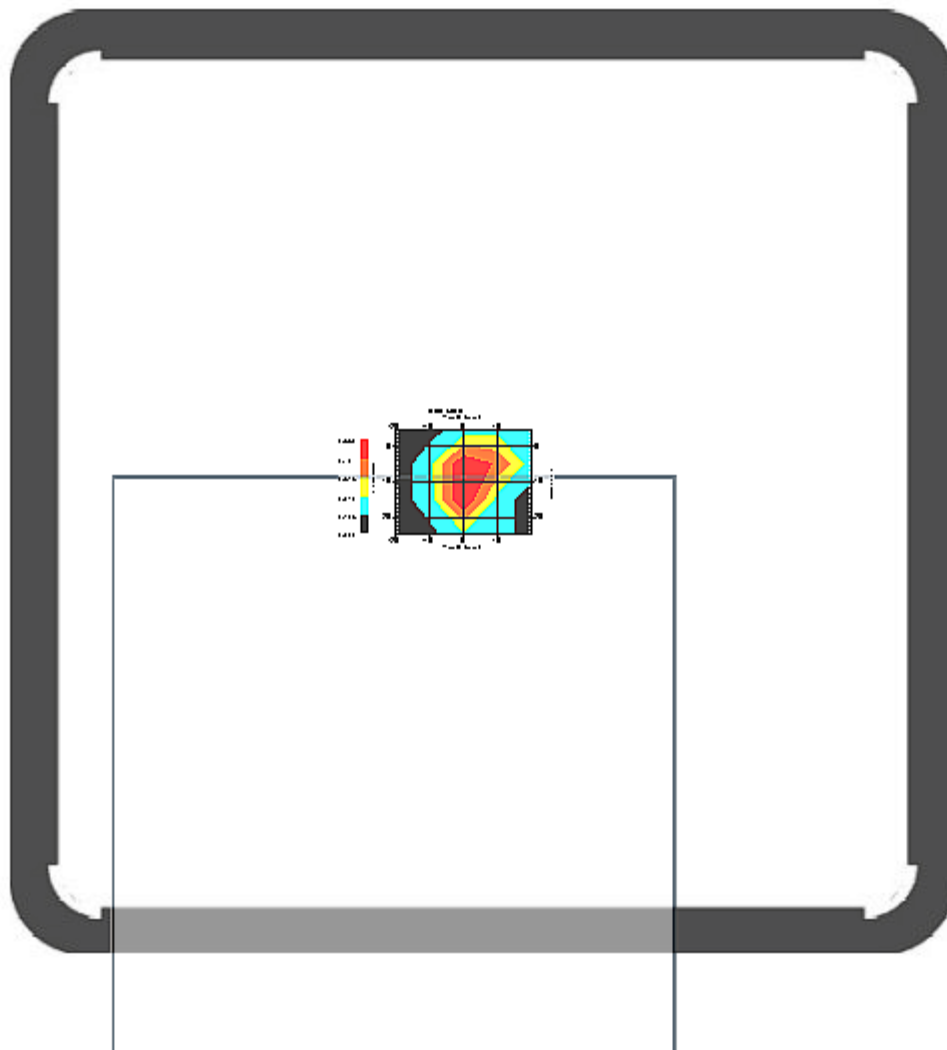

1 gram SAR value : 0.417 W/kg
10 gram SAR value : 0.174 W/kg
Area Scan Peak SAR : 0.528 W/kg
Zoom Scan Peak SAR : 0.990 W/kg

Exposure Assessment Measurement Uncertainty

Source of Uncertainty	Tolerance Value	Probability Distribution	Divisor	c_i^{-1} (1-g)	c_i^{-1} (10-g)	Standard Uncertainty (1-g) %	Standard Uncertainty (10-g) %
Measurement System							
Probe Calibration	3.5	normal	1	1	1	3.5	3.5
Axial Isotropy	3.7	rectangular	•3	$(1-cp)^{1/2}$	$(1-cp)^{1/2}$	1.5	1.5
Hemispherical Isotropy	10.9	rectangular	•3	•cp	•cp	4.4	4.4
Boundary Effect	1.0	rectangular	•3	1	1	0.6	0.6
Linearity	4.7	rectangular	•3	1	1	2.7	2.7
Detection Limit	1.0	rectangular	•3	1	1	0.6	0.6
Readout Electronics	1.0	normal	1	1	1	1.0	1.0
Response Time	0.8	rectangular	•3	1	1	0.5	0.5
Integration Time	1.7	rectangular	•3	1	1	1.0	1.0
RF Ambient Condition	3.0	rectangular	•3	1	1	1.7	1.7
Probe Positioner Mech.	0.4	rectangular	•3	1	1	0.2	0.2
Restriction							
Probe Positioning with respect to Phantom Shell	2.9	rectangular	•3	1	1	1.7	1.7
Extrapolation and Integration	3.7	rectangular	•3	1	1	2.1	2.1
Test Sample Positioning	4.0	normal	1	1	1	4.0	4.0
Device Holder Uncertainty	2.0	normal	1	1	1	2.0	2.0
Drift of Output Power	11.6	rectangular	•3	1	1	6.7	6.7
Phantom and Setup							
Phantom Uncertainty(shape & thickness tolerance)	3.4	rectangular	•3	1	1	2.0	2.0
Liquid Conductivity(target)	5.0	rectangular	•3	0.7	0.5	2.0	1.4
Liquid Conductivity(meas.)	138.6	normal	1	0.7	0.5	97.0	69.3
Liquid Permittivity(target)	5.0	rectangular	•3	0.6	0.5	1.7	1.4
Liquid Permittivity(meas.)	10.0	normal	1	0.6	0.5	6.0	5.0
Combined Uncertainty		RSS				97.9	70.4
Combined Uncertainty (coverage factor=2)		Normal (k=2)				195.7	140.8

SAR-Z Axis at Hotspot x:7.20 y:-0.50

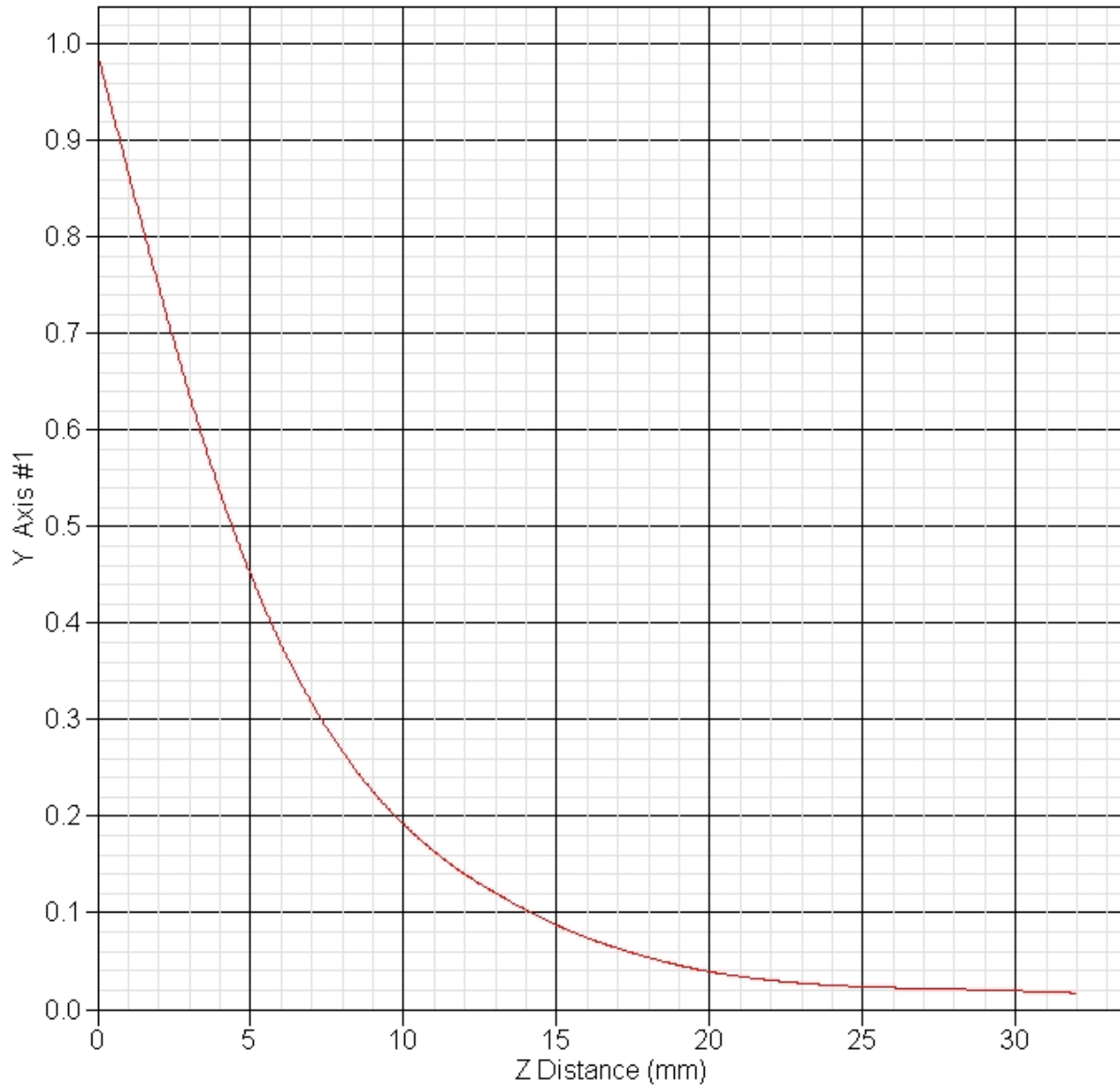

Appendix C – SAR Test Setup Photos



Figure 1 – Front of Device Main Antenna Touch Position



Figure 2 – Side of Device Main Antenna Touch Position

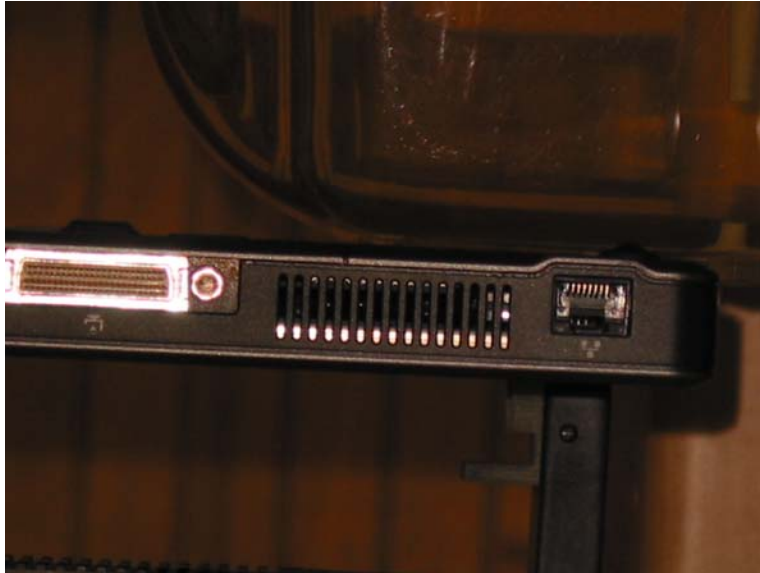

Figure 3 – Side of Device Aux Antenna Touch Position

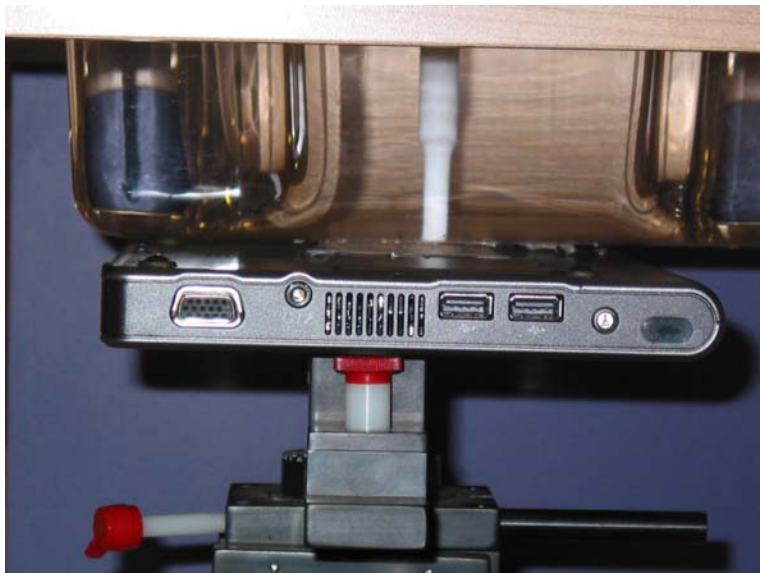

Figure 4 – Front of Device Main Antenna Touch Position



Figure 5 – Side of Device Main Antenna Touch Position

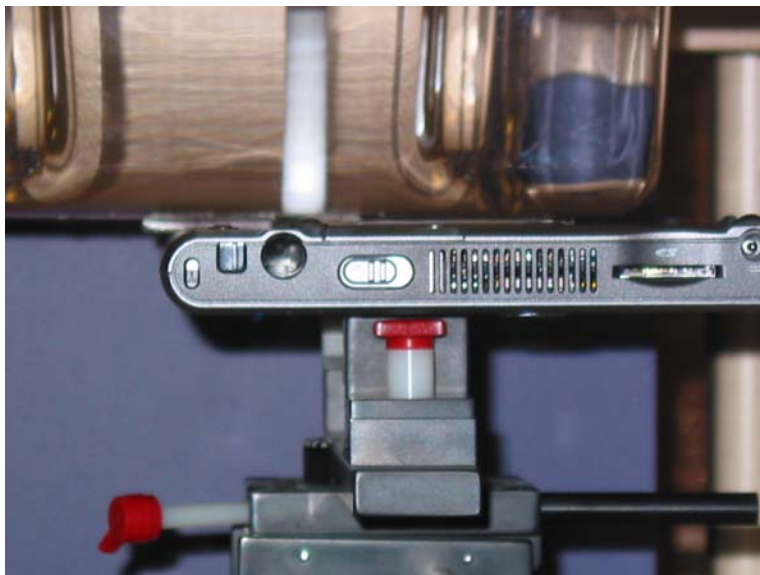

Figure 6 – Front of Device Aux Antenna Touch Position



Figure 7 – Side of Device Aux Antenna Touch Position



Figure 8 – Front of Device



Figure 9 – Back of Device



Figure 10 – Bottom case of Device



Figure 11 – Front of Battery



Figure 12 – Back of Battery



Figure 13 – Body Sugar Based Solution Tissue Depth

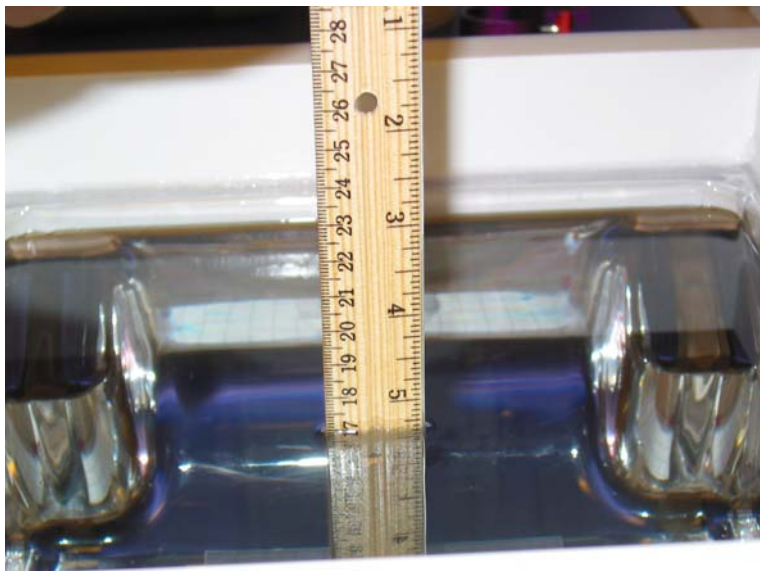

Figure 14 – Body Glycol Based Solution Tissue Depth