

TEST REPORT

Report Number: 3108751MPK015-1

Project Number: 3108751

December 21, 2006

**Testing performed on the
LE1700 Tablet PC**

Model Number: T006

FCC ID: Q3QAWM7519ABG

IC ID: 4587A-A7519ABG

to

FCC Part 15 Subpart C (15.247)

For 2.4 GHz Band Only

for

Motion Computing Inc.



A2LA Certificate Number: 1755-01

Test Performed by:

Intertek
1365 Adams Court
Menlo Park, CA 94025 USA

Test Authorized by:

Motion Computing Inc.
8601 Ranch Road 2222
Austin, TX 78730 USA

Prepared by:

Handwritten signature of Krishna K Vemuri in blue ink.

Krishna K Vemuri

Date: December 21, 2006

Reviewed by:

Handwritten signature of David Chernomordik in blue ink.

David Chernomordik,
EMC Technical Manager

Date: December 21, 2006

This report is for the exclusive use of Intertek's Client and is provided pursuant to the agreement between Intertek and its Client. Intertek's responsibility and liability are limited to the terms and conditions of the agreement. Intertek assumes no liability to any party, other than to the Client in accordance with the agreement, for any loss, expense or damage occasioned by the use of this report. Only the Client is authorized to copy or distribute this report and then only in its entirety. Any use of the Intertek name or one of its marks for the sale or advertisement of the tested material, product or service must first be approved in writing by Intertek. The observations and test results in this report are relevant only to the sample tested. This report by itself does not imply that the material, product, or service is or has ever been under an Intertek certification program. This report must not be used to claim product endorsement by A2LA, NIST nor any other agency of the U.S. Government.

TABLE OF CONTENTS

1.0	Introduction	3
2.0	Summary of Tests	4
3.0	General Description	5
3.1	Product Description	5
3.2	Test Methodology	6
3.3	Test Facility	6
4.0	Test Configuration	7
4.1	Support Equipment	7
4.2	Block Diagram of Test Setup.....	8
4.3	Justification	10
4.4	Software Exercise Program.....	10
4.5	Mode of Operation During Test.....	10
4.6	Modifications Required for Compliance	10
4.7	Additions, deviations and exclusions from standards.....	10
5.0	Measurement Results	11
5.1	Conducted output power	11
5.2	Transmitter Radiated Emissions in Restricted Bands	18
5.3	AC Line Conducted Emission	28
6.0	List of Test Equipment	34
7.0	Document History	35

1.0 Introduction

This report is intended to show compliance of the LE1700 Tablet PC, model: T006 to the rules of FCC Part 15, Subpart C for the 2.4 GHz band only.

As declared by the Applicant, the transmitter module, used in the model T006, is identical to the module which has been certified for Atheros Communications, Inc. (FCC ID: PPD-AR5BXB6-M, Model: WM7519A), except for the antenna. The antenna used in T006 model has less gain than the antenna in the certified WM7519A model. The output power is also reduced through software to comply with RF exposure (SAR) requirements.

The following test results, related to antenna conducted measurements, are not expected to be changed with reduced power setting. Therefore, these test results from the original Application are applicable to the model: T006.

TEST	REFERENCE	RESULTS
6 dB Bandwidth	15.247(a)(2)	Complies
Power Density	15.247(d)	Complies
Out of Band Antenna Conducted Emission	15.247(c)	Complies

The following tests are required to ensure compliance of the Model T006:

- Conducted output power
- Radiated Emissions in Restricted Bands
- AC Line Conducted Emission

2.0 Summary of Tests

FCC ID: Q3QAWM7519ABG
IC ID: 4587A-A7519ABG

TEST	REFERENCE	RESULTS
Conducted output power	15.247(b)	Complies
Radiated Emission in Restricted Bands	15.247(c), 15.209, 15.205	Complies
AC Line Conducted Emission	15.207	Complies

EUT receive date: November 28, 2006

EUT receive condition: The EUT was received in good condition with no apparent damage.

Test start date: November 28, 2006

Test completion date: December 19, 2006

The test results in this report pertain only to the item tested.

3.0 General Description

3.1 Product Description

The model T006 is an LE1700 Tablet PC using windows XP for office and home environment. It provides a wireless interface IEEE 802.11a/b/g operating at 2.4 GHz and 5 GHz bands and one 10/100BASE-T Ethernet interface.

Overview of the Equipment under Test:

Applicant	Motion Computing Inc.
Model No.	T006
Wireless Interface under test	IEEE 802.11b/g
FCC Identifier/ IC Identifier	FCC ID: Q3QAWM7519ABG IC ID: 4587A-A7519ABG
Use of Product	LE1700 Tablet PC
Manufacturer & FCC ID of Transmitter Module	Atheros Communications, Inc. (FCC ID: PPD-AR5BXB6-M)
Type of Transmission	IEEE 802.11b/g
Frequency Range	2412 - 2462 MHz
Rated RF Output Power *	16.5 dBm - for 802.11b (data rates: 1 – 11 Mbps) 16.5 dBm - for 802.11g (data rates: 6 – 36 Mbps) 16.0 dBm - for 802.11g (data rate: 48 Mbps) 15.0 dBm - for 802.11g (data rate: 54 Mbps)
Number of Channel(s)	11
Antenna	Integrated antenna, 0 dBi gain
Manufacturer Name & Address	Motion Computing Inc. 8601 Ranch Road 2222 Austin, TX 78730 USA

* As declared by the Applicant, actual production units will be calibrated to these power levels. The SAR test and the tests performed in this Test Report were performed with slightly higher power levels. The stated Rated RF Output Power of production units will be set lower than the power used during testing to ensure compliance.

3.2 Test Methodology

Both AC mains line-conducted and radiated emissions measurements were performed according to the procedures in ANSI C63.4 (2003). Radiated tests were performed at an antenna to EUT distance of 3 meters, unless stated otherwise in the "**Data Sheet**" of this Application. All other measurements were made in accordance with the procedures in part 2 of CFR 47.

3.3 Test Facility

The test facility is located at 1365 Adams Court, Menlo Park, California, 94025. The test site for radiated emission measurements is 10-m semi-anechoic chamber. This test facility and site measurement data have been fully placed on file with the FCC and is A2LA accredited.

4.0 Test Configuration

4.1 Support Equipment

Item #	Description	Model No.	Serial No.
1	Dual Wireless A+G Broadband Router	WRT55AG	MDJ106700080
2	Speakers	SP-12	Not Labeled
3	RCA Headphones	---	---
4	Netgear 5 port 10/100/1000 Mbs Gigabit switch	GS605	GS19147DB002667
5	Motion Computing DVD+/- RW Drive	EDW085	CN-042020006-00381-69E-00A8
6	Philips Monitor	107S11/74	32131535
7	USB Flash Drive	---	Not Labeled

4.2 Block Diagram of Test Setup

For Radiated Measurements:

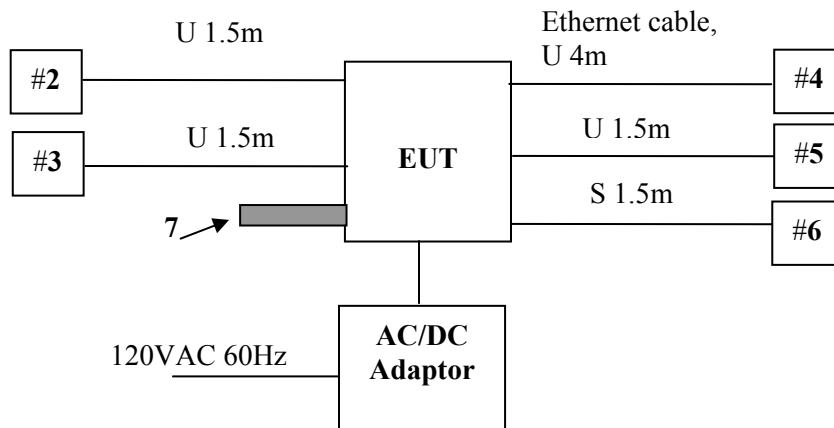

AC/DC Adaptor: Delta Electronics, ADP-50HH Rev. B, S/N. KOW0641001371

S = Shielded	F = With Ferrite
U = Unshielded	m = Length in Meters

For AC Line-conducted Measurements:

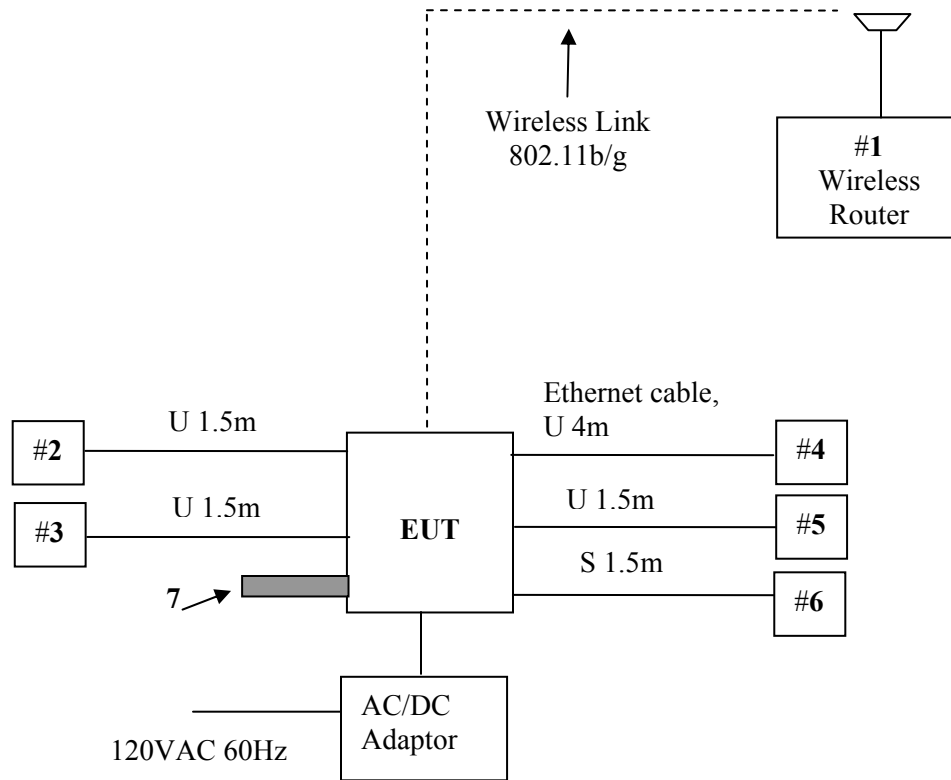

AC/DC Adaptor: Delta Electronics, ADP-50HH Rev. B, S/N. KOW0641001371

S = Shielded	F = With Ferrite
U = Unshielded	m = Length in Meters

4.3 Justification

For emission testing, the equipment under test (EUT) was configured for testing in a typical fashion (as a customer would normally use it). During testing, all cables were manipulated to produce worst case emissions.

4.4 Software Exercise Program

A test signal with different modulations was generated by the test mode software (Atheros Communications ART software).

4.5 Mode of Operation During Test

For the transmitter testing, the EUT was setup in the test mode to transmit continuously a modulated signal at lowest (Ch 1), middle (Ch 6) and highest (Ch 11) channels (frequencies). The worst case settings as per Atheros Communications were used for the tests (Bit rate: 1 Mbps - for 802.11b, Bit rate: 6 Mbps - for 802.11g). Test was performed in 802.11b and 802.11g modes and worst case readings were reported.

For AC line-conducted measurement, a wireless link was established to a Linksys AG Access Point in 802.11b/g wireless interface and streaming the video over wireless link. The video & I/O ports functionality was tested using proprietary EMI exerciser software.

4.6 Modifications Required for Compliance

Intertek installed no modifications during compliance testing in order to bring the product into compliance (Please note that this does not include changes made specifically by Motion Computing Inc. prior to compliance testing)

4.7 Additions, deviations and exclusions from standards

No additions, deviations or exclusions from the standard were made.

5.0 Measurement Results

5.1 Conducted output power

Procedure

For conducted power measurement for FCC Part 15C testing, the procedure “**Measurement of Digital Transmission Systems Operating under Section 15.247**” is used. In particular – the **Power Output Option 2, Method #1**, - spectral trace averaging and sum the power across the 26-dB bandwidth of the signal.

The 26-dB bandwidth was measured and recorded as 18 MHz – in 802.11b mode, 21 MHz – in 802.11g mode. Then the average power was measured by using a spectrum analyzer built-in facility for “channel power” measurement.

Note: The measured conducted output power levels are the same as the levels measured during SAR testing. As declared by the Applicant, actual production units will be calibrated to the stated Rated RF Output Power listed in section 3.1 of this test report. The testing was performed with slightly higher power levels. The stated Rated RF Output Power of production units will be set lower than the power used during testing to ensure compliance.

Test Result

The results are presented on the following plots 1.1 – 1.6 and summarized in the table below.

Channel	Frequency MHz	Standard	Date rate Mbps	Conducted power (average) dBm	Conducted power Limit dBm	Margin dB
1	2412	802.11g	6	17.0	30.0	-13.0
1	2412	802.11b	1	16.8	30.0	-13.2
6	2437	802.11g	6	16.6	30.0	-13.4
6	2437	802.11b	1	16.6	30.0	-13.4
11	2462	802.11g	6	16.6	30.0	-13.4
11	2462	802.11b	1	16.4	30.0	-13.6

Plot 1.1

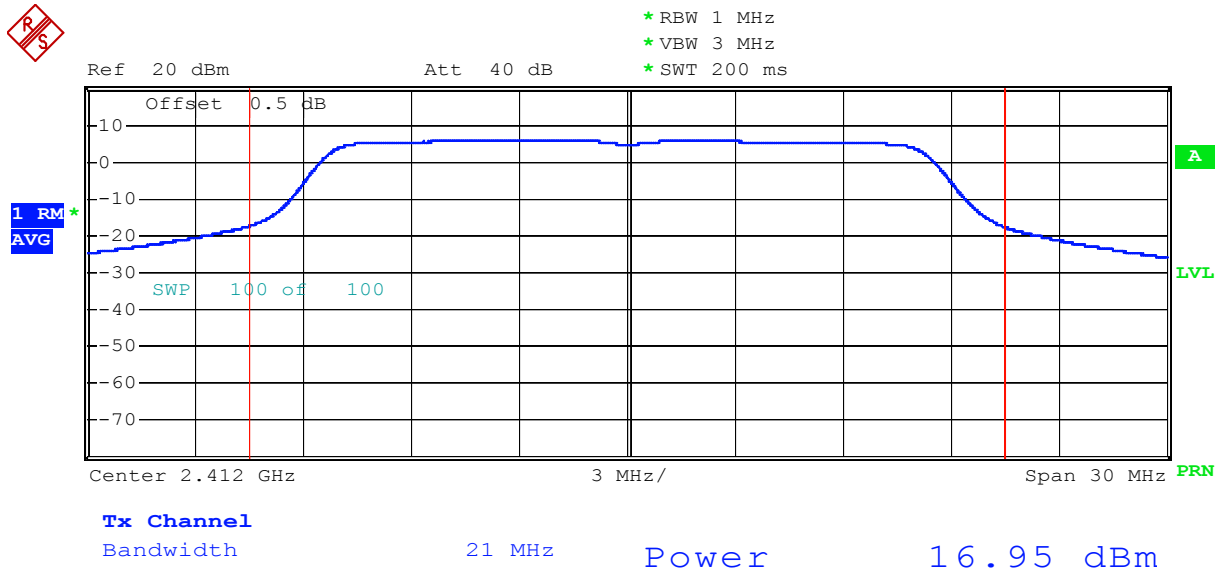

Comment: Power, 2412 MHz, 802.11g, 6 Mbps
Date: 10.JAN.2007 15:00:36

Plot 1.2

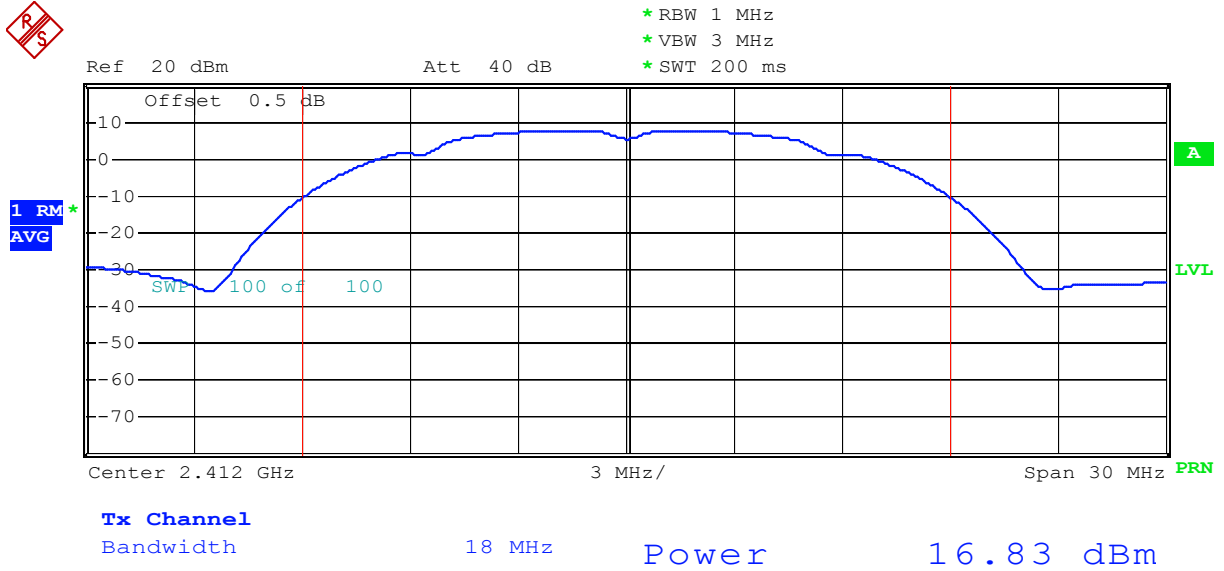

Comment: Power, 2412 MHz, 802.11b, 1 Mbps
Date: 10.JAN.2007 15:03:39

Plot 1.3

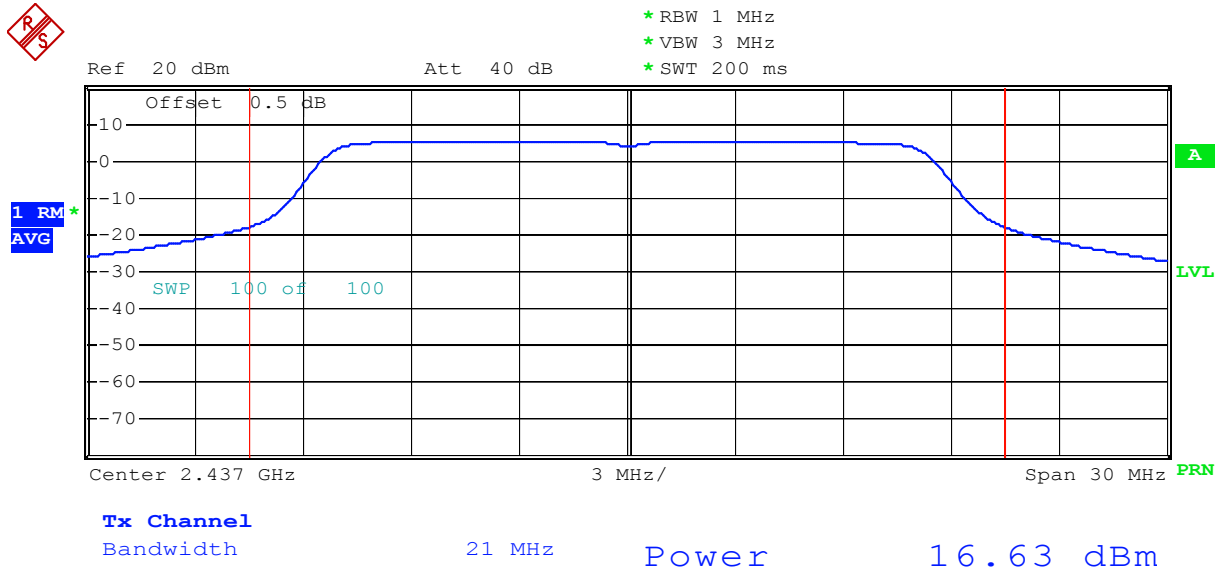

Comment: Power, 2437 MHz, 802.11g, 6 Mbps
Date: 10.JAN.2007 15:06:54

Plot 1.4

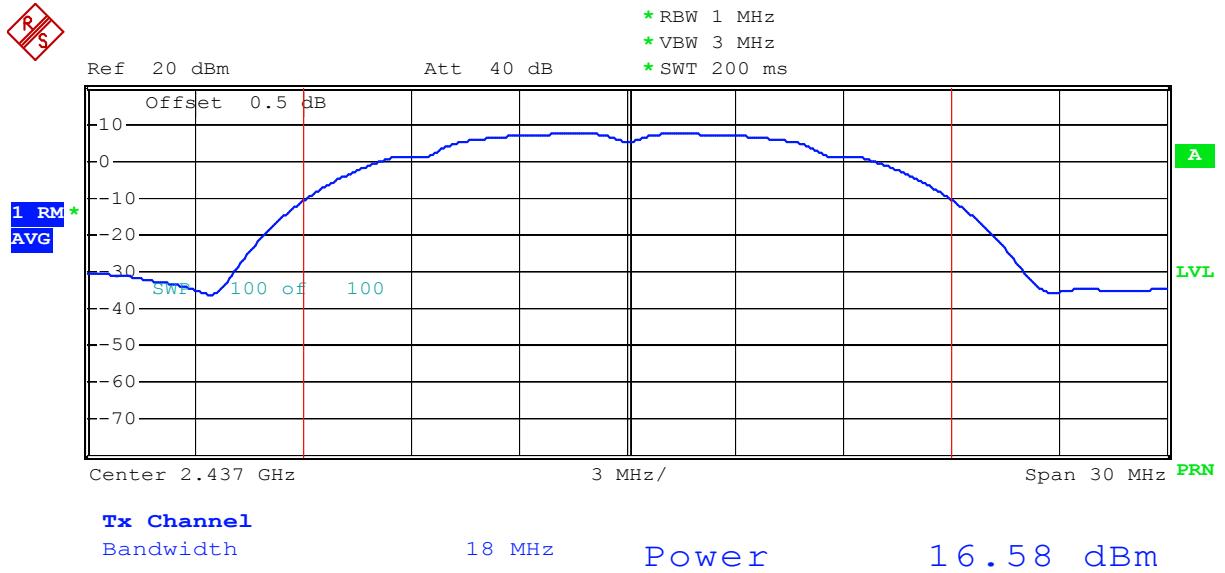

Comment: Power, 2437 MHz, 802.11b, 1 Mbps
Date: 10.JAN.2007 15:09:00

Plot 1.5

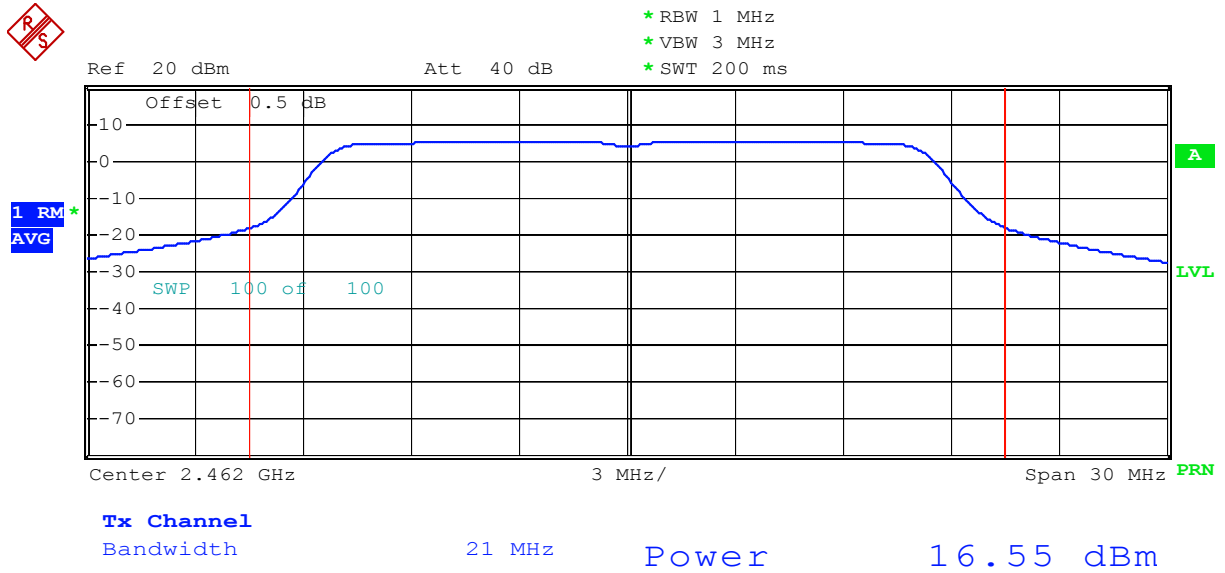

Comment: Power, 2462 MHz, 802.11g, 6 Mbps
 Date: 10.JAN.2007 15:11:13

Plot 1.6

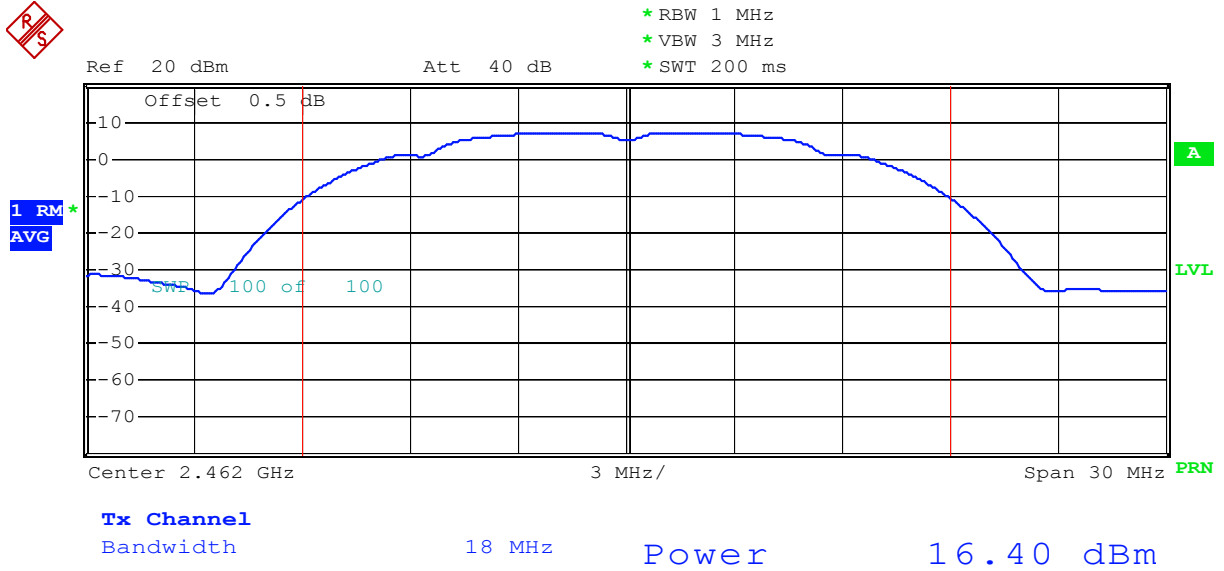

Comment: Power, 2462 MHz, 802.11b, 1 Mbps
 Date: 10.JAN.2007 15:13:18

5.2 Transmitter Radiated Emissions in Restricted Bands FCC Rule 15.247(c), 15.209, 15.205

Procedure

Radiated emission measurements were performed from 30 MHz to 25,000 MHz. Spectrum Analyzer Resolution Bandwidth is 100 kHz or greater for frequencies 30 MHz to 1000 MHz, 1 MHz - for frequencies above 1000 MHz.

The EUT is placed on a non-conductive table. If the EUT attaches to peripherals, they are connected and operational (as typical as possible). During testing, all cables were manipulated to produce worst case emissions.

The signal is maximized through rotation. The antenna height and polarization are varied during the search for maximum signal level. The antenna height is varied from 1 to 4 meters.

Radiated emissions are taken at three meters unless the signal level is too low for measurement at that distance. If necessary, a pre-amplifier is used and/or the test is conducted at a closer distance. All readings are extrapolated back to the equivalent three-meter reading using inverse scaling with distance.

Data is included of the worst case configuration (the configuration which resulted in the highest emission levels).

Field Strength Calculation

The field strength is calculated by adding the Antenna Factor and Cable Factor, and subtracting the Amplifier Gain (if any) from the measured reading. The basic equation with a sample calculation is as follows:

$$FS = RA + AF + CF - AG$$

Where FS = Field Strength in dB(μ V/m)

RA = Receiver Amplitude (including preamplifier) in dB(μ V); AF = Antenna Factor in dB(1/m)

CF = Cable Attenuation Factor in dB; AG = Amplifier Gain in dB

Assume a receiver reading of 52.0 dB(μ V) is obtained. The antennas factor of 7.4 dB(1/m) and cable factor of 1.6 dB is added. The amplifier gain of 29 dB is subtracted, giving field strength of 32 dB(μ V/m). This value in dB(μ V/m) was converted to its corresponding level in μ V/m.

$$RA = 52.0 \text{ dB}(\mu\text{V})$$

$$AF = 7.4 \text{ dB}(1/\text{m})$$

$$CF = 1.6 \text{ dB}$$

$$AG = 29.0 \text{ dB}$$

$$FS = 52.0 + 7.4 + 1.6 - 29.0 = 32 \text{ dB}(\mu\text{V}/\text{m})$$

$$\text{Level in } \mu\text{V}/\text{m} = \text{Common Antilogarithm} [(32 \text{ dB}\mu\text{V}/\text{m})/20] = 39.8 \mu\text{V}/\text{m}$$

Test Result

The data on the following pages lists the significant emission frequencies, the limit and the margin of compliance for the worst-case configuration.

The EUT passed the test by 2.4 dB.

Temperature: 20.0 C	Company: Motion Computing Inc.
Humidity: 50.0 %	Model: T006
Date: December 08, 2006	

Frequency MHz	Polarity	Detector	SA reading dB (uV)	AG** dB	Ant factor dB(1/m)	Field Strength dB(uV/m)	Limit dB(uV/m)	Margin dB
Ch: 1, 2412 MHz								
4824.0	V	Pk	47.7	27.6	33.7	53.8	74.0	-20.2
4824.0	V	Av	45.5	27.6	33.7	51.6	54.0	-2.4
7236.0	V	Pk	42.3	24.5	36.4	54.2	74.0	-19.8
7236.0	V	Av	30.5	24.5	36.4	42.4	54.0	-11.6
12060.0*	V	Pk	29.7	17.8	39.6	51.5	74.0	-22.5
12060.0*	V	Av	16.1	17.8	39.6	37.9	54.0	-16.1
Ch: 6, 2437 MHz								
4874.0	V	Pk	46.6	28.1	33.8	52.3	74.0	-21.7
4874.0	V	Av	44.4	28.1	33.8	50.1	54.0	-3.9
7311.0	V	Pk	41.6	24.8	36.5	53.3	74.0	-20.7
7311.0	V	Av	29.3	24.8	36.5	41.0	54.0	-13.0
12185.0*	V	Pk	29.7	17.2	39.5	52.0	74.0	-22.0
12185.0*	V	Av	16.2	17.2	39.5	38.5	54.0	-15.5
Ch: 11, 2462 MHz								
4924.0	V	Pk	46.9	28.0	33.9	52.8	74.0	-21.2
4924.0	V	Av	45.0	28.0	33.9	50.9	54.0	-3.1
7386.0	V	Pk	42.2	25.0	36.7	53.9	74.0	-20.1
7386.0	V	Av	29.5	25.0	36.7	41.2	54.0	-12.8
12310.0*	V	Pk	29.7	14.9	39.4	54.2	74.0	-19.8
12310.0*	V	Av	16.1	14.9	39.4	40.6	54.0	-13.4

Frequency MHz	Polarity	Detector	SA reading dB (uV)	Cable Factor dB	Ant factor dB(1/m)	Field Strength dB(uV/m)	Limit dB(uV/m)	Margin dB
1440.0	V	Pk	22.6	2.2	25.7	50.5	74.0	-23.5
1440.0	V	Av	12.4	2.2	25.7	40.3	54.0	-13.7
2499.9	V	Pk	23.2	3.8	28.8	55.8	74.0	-18.2
2499.9	V	Av	13.1	3.8	28.8	45.7	54.0	-8.3

*Noise floor

**AG – Amplifier Gain includes Cable Attenuation Factor.



All other emissions not reported are at least 6 dB below the limit.

**Radiated Emission in Restricted Bands at the band-edge frequencies
(measured using radiated method)**

Band-edge frequency	Average FS, dB(uV/m)	Average Limit, dB(uV/m)	Margin, dB	Plot
2483.5 MHz	42.9	54	-11.1	2.1
2390.0 MHz	42.3	54	-11.7	2.2

Note:

1. The antenna factor and cable loss are included in the spectrum analyzer OFFSET. Therefore “Marker 2” Reading is the average value of the Field Strength at 2390 MHz and 2483.5 MHz.
2. The Peak reading is no more than 10 dB higher than average reading, therefore it complies with peak FS limit of 74 dB(uV/m)

Plot 2.1

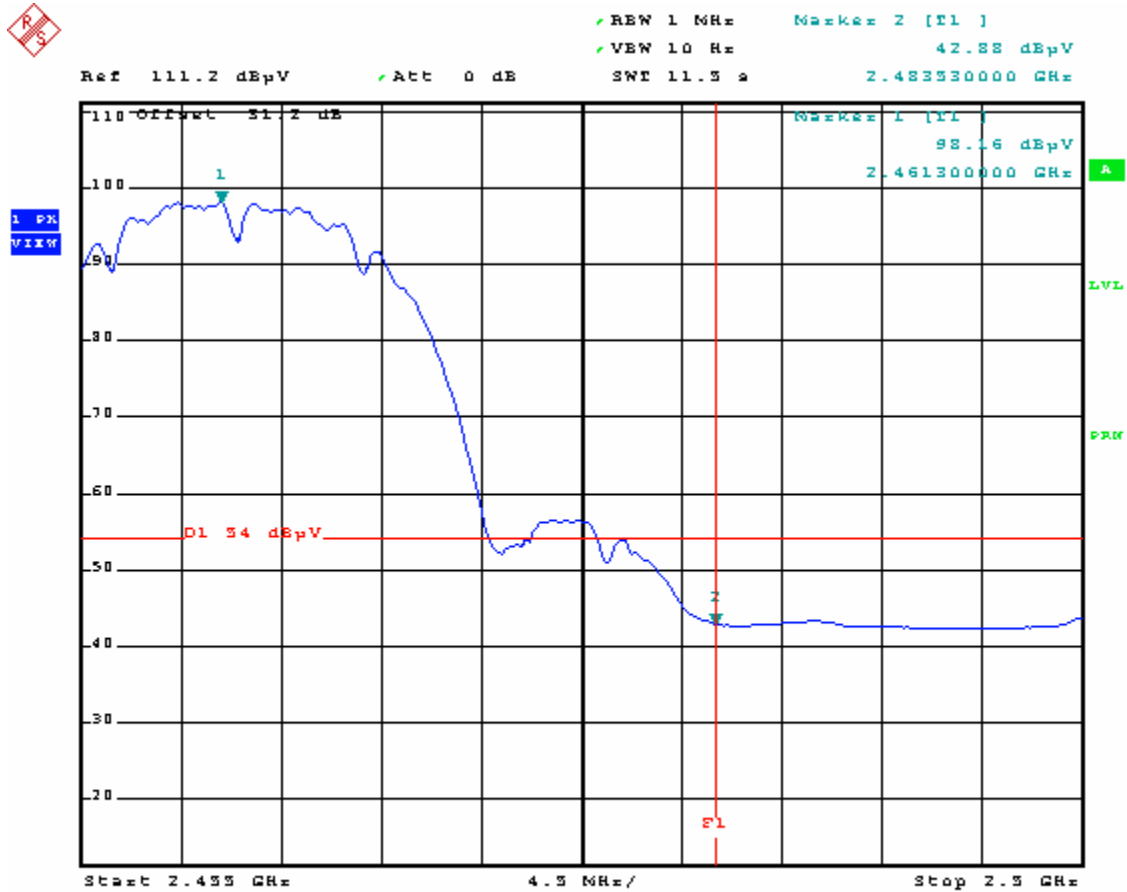

Comment: Band Edge, Ch 11
 Date: 8.DEC.2006 18:43:48

Plot 2.2

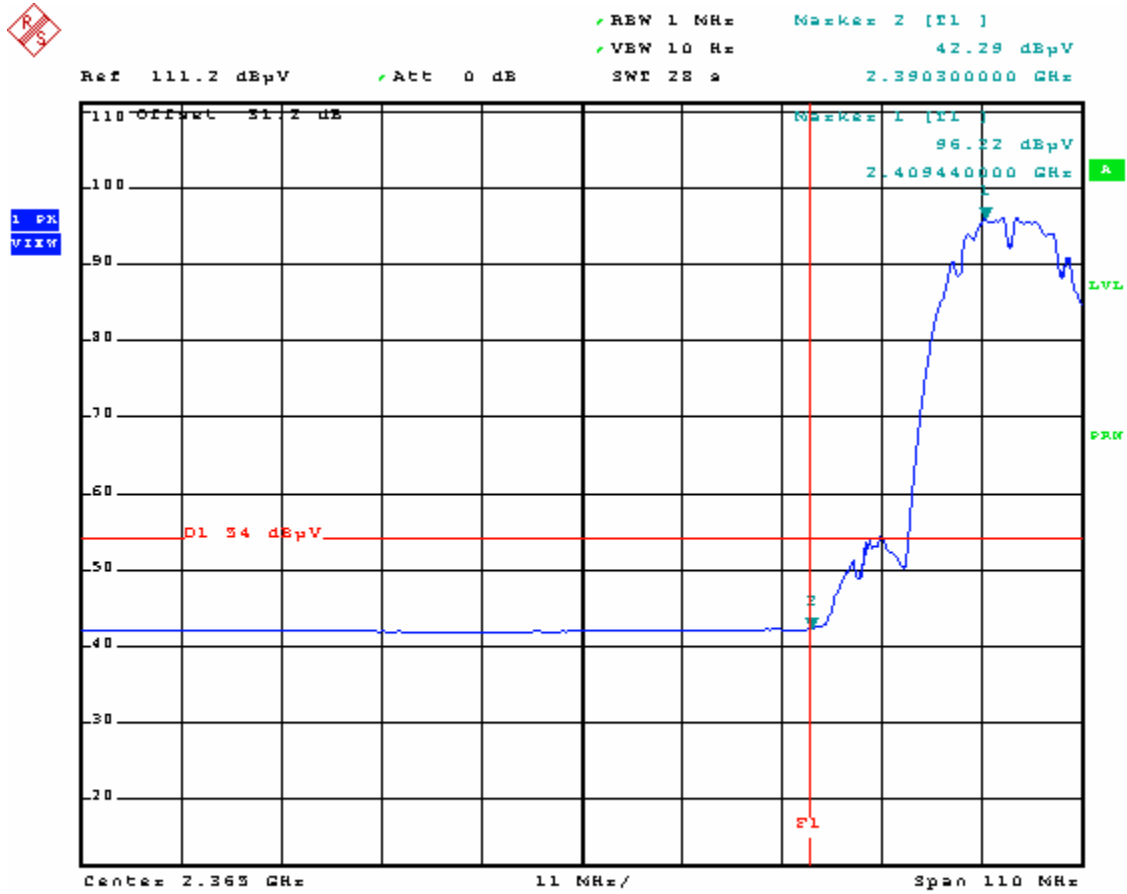

Comment: Band Edge, Ch 1
 Date: 8.DEC.2006 18:23:02

Configuration photographs



Configuration photographs-Continued



Configuration photographs-Continued



5.3 AC Line Conducted Emission
FCC Rule 15.207:

Procedure

AC line conducted emission test was performed according the ANSI C63.4 (2003) standard. The EUT was connected to the AC Line through the LISN.

Test Result

For the test result, see the following pages.
The EUT passed by 11.3 dB.

AC Line Conducted Emission data

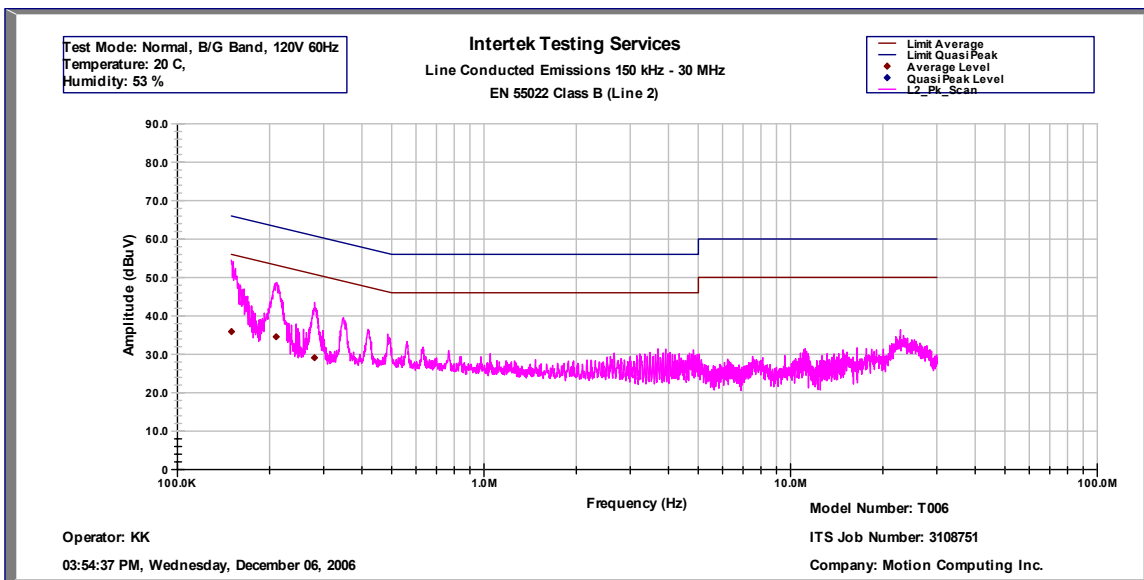
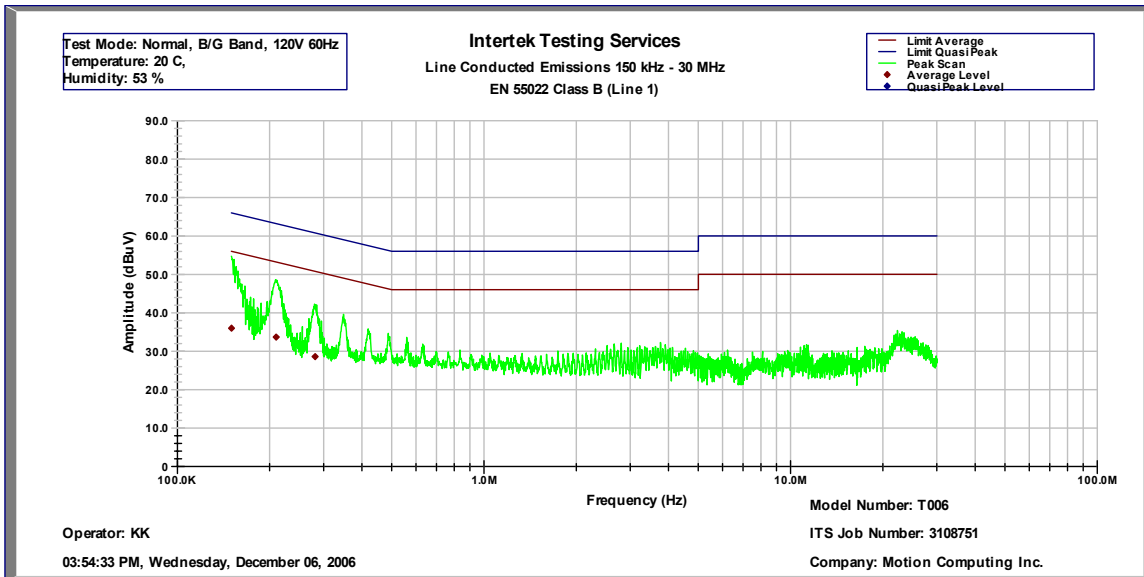

AC Line Conducted Emission data

Intertek Testing Services							
Line Conducted Emissions 150 kHz - 30 MHz							
FCC Part 15B/EN 55022 Class B (Line 1)							
Operator: KK				Model Number: T006			
				ITS Job Number: 3108751			
03:54:33 PM, Wednesday, December 06, 2006				Company: Motion Computing Inc.			
Frequency	Pk Level	Av Level	QP Level	Av Limit	QP Limit	Av Margin	QP Margin
MHz	(dBuV)	(dBuV)	(dBuV)	(dBuV)	(dBuV)	(dB)	(dB)
0.1502	54.7	36.0	-	56.0	66.0	-20.0	-11.3
0.2100	48.6	33.7	-	54.3	64.3	-20.6	-15.7
0.2813	42.0	28.6	-	52.2	62.2	-23.7	-20.2

Test Mode: Normal, 802.11b/g mode, 120V 60Hz
 Temperature: 20 C,
 Humidity: 53 %

Intertek Testing Services							
Line Conducted Emissions 150 kHz - 30 MHz							
FCC Part 15B/EN 55022 Class B (Line 2)							
Operator: KK				Model Number: T006			
				ITS Job Number: 3108751			
03:54:37 PM, Wednesday, December 06, 2006				Company: Motion Computing Inc.			
Frequency	Pk Level	Av Level	QP Level	Av Limit	QP Limit	Av Margin	QP Margin
MHz	(dBuV)	(dBuV)	(dBuV)	(dBuV)	(dBuV)	(dB)	(dB)
0.1502	54.5	35.9	-	56.0	66.0	-20.1	-11.5
0.2100	48.2	34.6	-	54.3	64.3	-19.7	-16.1
0.2800	43.5	29.1	-	52.3	62.3	-23.2	-18.8

Test Mode: Normal, 802.11b/g mode, 120V 60Hz
 Temperature: 20 C,
 Humidity: 53 %

Configuration photograph



Configuration photographs-Continued



Configuration photographs-Continued

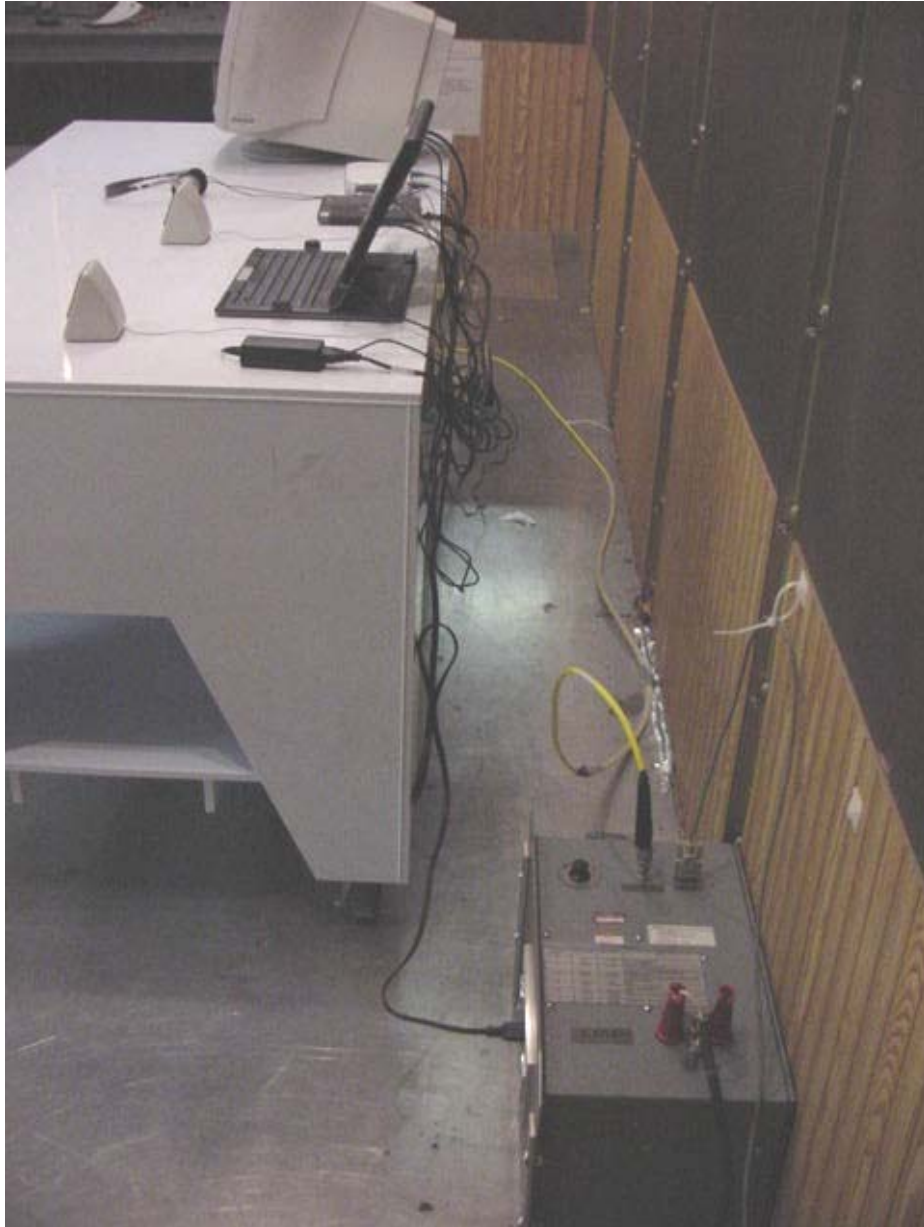

6.0 List of Test Equipment

Measurement equipment used for emission compliance testing utilized the equipment on the following list:

EQUIPMENT	MANUFACTURER	MODEL NUMBER	SERIAL NUMBER	CAL. INTERVAL	CAL. DUE
RF Filter Section	Hewlett Packard	85460A	3448A00267	12	9/11/07
EMI Receiver	Hewlett Packard	8546A	3710A00373	12	9/11/07
Spectrum Analyzer	R & S	FSP40	036612004	12	7/12/07
Signal Generator	Hewlett Packard	83732A	3222A00119	12	3/30/07
BI-Log Antenna	ARA Inc.	1154	LPB-2513/A	12	8/29/07
Horn Antenna	EMCO	3115	9170-3712	12	7/26/07
Pre-Amplifier	Sonoma Inst.	310	185634	12	2/20/07
Pre-Amplifier	Miteq	AMF-4D-001180-24-10P	799159	12	4/03/07
High Pass Filter	Reactel	7HS-4/18 S11	(94)3	#	#
LISN	FCC	FCC-LISN-50-50-M-H	2012	12	7/19/07
Spectrum Analyzer	Hewlett Packard	8591EM	3801A01250	12	9/13/07

Calibration performed by ITS prior to the test

7.0 Document History

Revision/ Job Number	Writer Initials	Date	Change
1.0 / 3108751	KK	December 21, 2006	Original document