

VERSIONS		REVISIONS			
VERSION	VERSION DESCRIPTION	REV	DESCRIPTION	DATE	APPROVED
-100	GENERIC	01	INITIAL RELEASE	05-JUN-03	

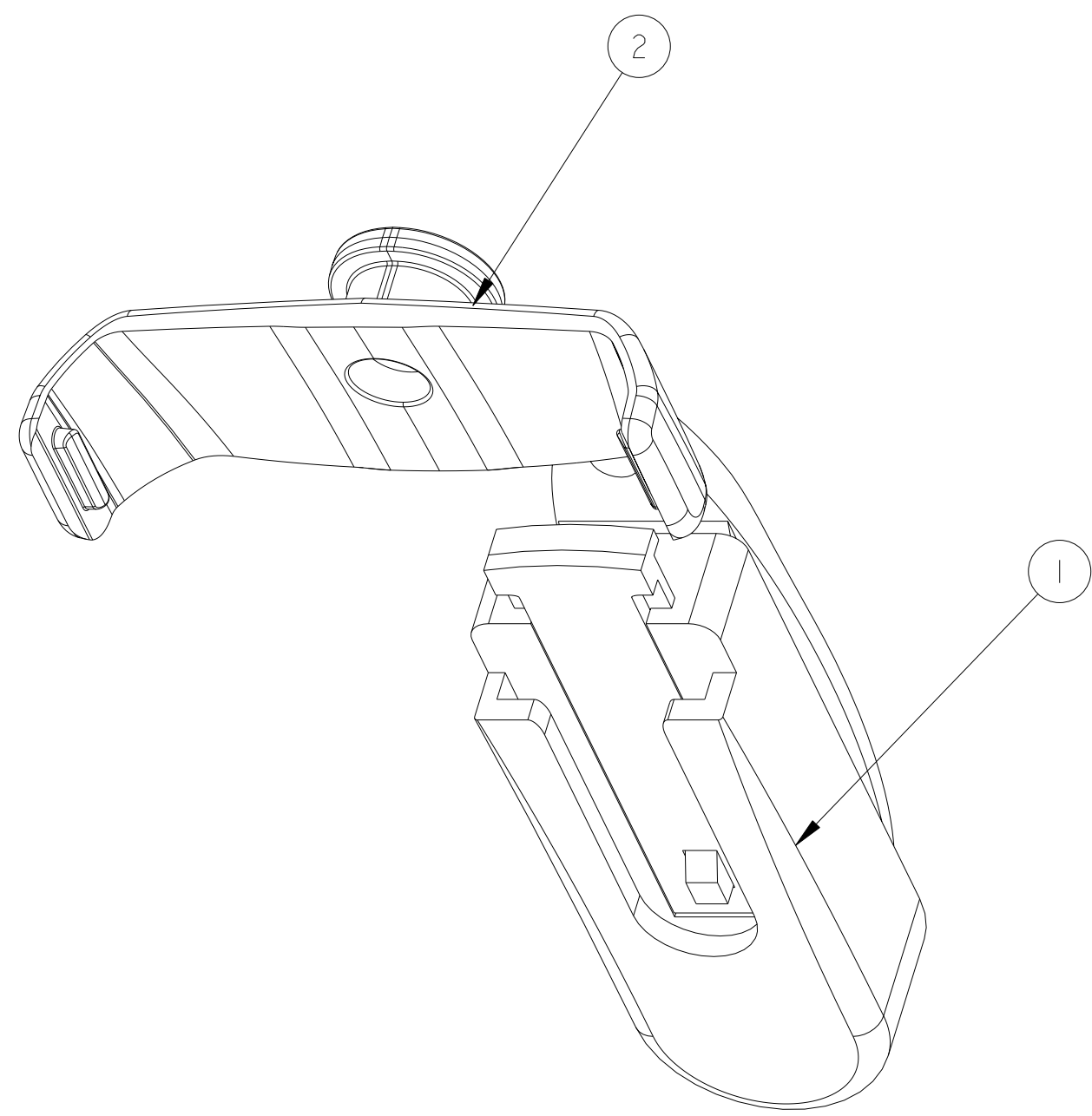

STEP 1

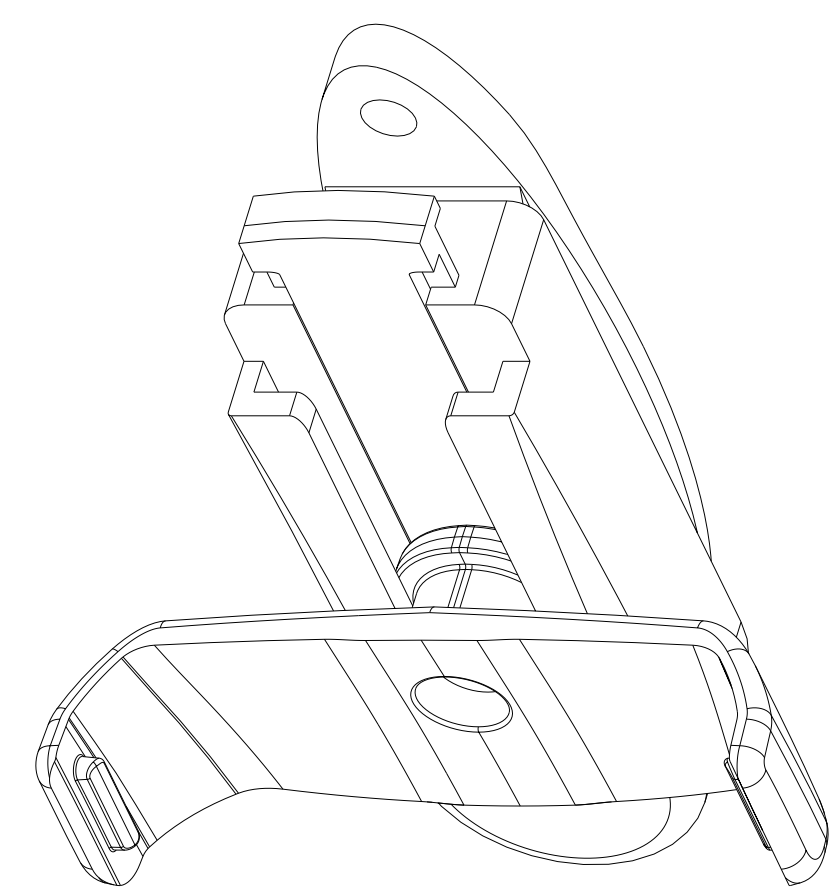

STEP 2

NOTES: (UNLESS OTHERWISE SPECIFIED)

STEP 1: ALIGN CYLINDRICAL PROTRUSION OF HOLSTER TO U-SHAPED SLOT IN BELT CLIP.

STEP 2: SLIDE HOLSTER DOWN SLOT UNTIL SNAPPED IN PLACE.

ITEM	QTY.	DESCRIPTION	PART NUMBER
2	1	HOLSTER	ODMCP09101001
1	1	BELT CLIP	ODMCP09101004
BILL OF MATERIALS			

DIMENSIONS ARE IN: MILLIMETERS				PROJECT		<b>FLEXTRONICS DESIGN, INC.</b>	
GENERAL TOLERANCES				DRWG LEVEL			
	X	X.X	X.XX	FLEXTRONICS DESIGN		05-JUN-03	
STD. DIM	±0.5	±0.25	±0.15	PRO/E PRT/ASM FILENAME: PHONE4K-BELT-CLIP-ASSY.PRT			
ANGLE	±3°	±1°	±0.5°	PRO/E DRW FILENAME: PHONE4K-BELT-CLIP-ASSY.DRW			
RADIUS	±25%	±10%	±5%	THIS DRAWING CONTAINS INFORMATION PROPRIETARY TO FLEXTRONICS AND SHALL NOT BE USED IN WHOLE OR IN PART WITHOUT CONSENT.			
SCALE: 2:1						PART NO.	REV
						ODMCP09101005	
						SHEET 1 OF 1	

D  
C  
B  
A