

# TEST REPORT

## CERTIFICATE OF CONFORMITY

**Standard:** 47 CFR FCC Part 22  
47 CFR FCC Part 24  
47 CFR FCC Part 27  
47 CFR FCC Part 2

**Report No.:** RFBCM-N-WTW-P23100614-7

**FCC ID:** Q3N-RS38

**Product:** Mobile Computer

**Brand:** CIPHERLAB

**Model No.:** RS38

**Received Date:** 2023/11/12

**Test Date:** 2024/1/8 ~ 2024/7/19

**Issued Date:** 2024/8/14

**Applicant:** Cipherlab Co., Ltd.

**Address:** 12F, 333 Dunhua S. Rd., Sec. 2, Taipei, Taiwan 10669

**Issued By:** Bureau Veritas Consumer Products Services (H.K.) Ltd., Taoyuan Branch  
Lin Kou Laboratories

**Lab Address:** No. 47-2, 14th Ling, Chia Pau Vil., Lin Kou Dist., New Taipei City, Taiwan

**Test Location(1):** No. 19, Hwa Ya 2nd Rd., Wen Hwa Vil., Kwei Shan Dist., Taoyuan City 33383, Taiwan

**Test Location(2):** No. 70, Wenming Rd., Guishan Dist., Taoyuan City 333, Taiwan (R.O.C.)

**FCC Registration /** 788550 / TW0003 for Test Location(1)

**Designation Number:** 281270 / TW0032 for Test Location(2)

**Approved by:** \_\_\_\_\_

*Jeremy Lin*

**Date:** \_\_\_\_\_

2024/8/14

Jeremy Lin / Project Engineer

This test report consists of 121 pages in total. It may be duplicated completely for legal use with the approval of the applicant. It should not be reproduced except in full, without the written approval of our laboratory. The test results in the report only apply to the tested sample. The test results in this report are traceable to the national or international standards.



Prepared by : Polly Chien / Specialist

This report is governed by, and incorporates by reference, the Conditions of Testing as posted at the date of issuance of this report at <http://www.bureauveritas.com/home/about-us/our-business/cps/about-us/terms-conditions/> and is intended for your exclusive use. Any copying or replication of this report to or for any other person or entity, or use of our name or trademark, is permitted only with our prior written permission. This report sets forth our findings solely with respect to the test samples identified herein. The results set forth in this report are not indicative or representative of the quality or characteristics of the lot from which a test sample was taken or any similar or identical product unless specifically and expressly noted. Our report includes all of the tests requested by you and the results thereof based upon the information that you provided to us. Measurement uncertainty is only provided upon request for accredited tests. Statements of conformity are based on simple acceptance criteria without taking measurement uncertainty into account, unless otherwise requested in writing. You have 60 days from date of issuance of this report to notify us of any material error or omission caused by our negligence or if you require measurement uncertainty; provided, however, that such notice shall be in writing and shall specifically address the issue you wish to raise. A failure to raise such issue within the prescribed time shall constitute your unqualified acceptance of the completeness of this report, the tests conducted and the correctness of the report contents.

## Table of Contents

<b>Release Control Record</b> .....	<b>4</b>
<b>1 Certificate</b> .....	<b>5</b>
<b>2 Summary of Test Results</b> .....	<b>6</b>
2.1 Measurement Uncertainty .....	7
2.2 Supplementary Information .....	7
<b>3 General Information</b> .....	<b>8</b>
3.1 General Description of EUT .....	8
3.2 Antenna Description of EUT .....	9
3.3 Test Mode Applicability and Tested Channel Detail .....	10
3.4 Test Program Used and Operation Descriptions .....	13
3.5 Connection Diagram of EUT and Peripheral Devices .....	13
3.6 Configuration of Peripheral Devices and Cable Connections .....	13
<b>4 Test Instruments</b> .....	<b>14</b>
4.1 Effective Radiated Power and Equivalent Isotropically Radiated Power .....	14
4.2 Modulation Characteristics .....	14
4.3 Peak to Average Ratio .....	14
4.4 Bandwidth .....	14
4.5 Conducted Spurious Emissions .....	14
4.6 Radiated Spurious Emissions below 1GHz .....	15
4.7 Radiated Spurious Emissions above 1GHz .....	16
4.8 Frequency Stability .....	17
<b>5 Limits of Test Items</b> .....	<b>18</b>
5.1 Effective Radiated Power and Equivalent Isotropically Radiated Power .....	18
5.2 Modulation Characteristics .....	18
5.3 Peak to Average Ratio .....	18
5.4 Bandwidth .....	18
5.5 Conducted Spurious Emissions .....	18
5.6 Radiated Spurious Emissions below 1GHz .....	19
5.7 Radiated Spurious Emissions above 1GHz .....	19
5.8 Frequency Stability .....	19
<b>6 Test Arrangements</b> .....	<b>20</b>
6.1 Effective Radiated Power and Equivalent Isotropically Radiated Power .....	20
6.1.1 Test Setup .....	20
6.1.2 Test Procedure .....	20
6.2 Modulation Characteristics .....	21
6.2.1 Test Setup .....	21
6.2.2 Test Procedure .....	21
6.3 Peak to Average Ratio .....	21
6.3.1 Test Setup .....	21
6.3.2 Test Procedure .....	21
6.4 Bandwidth .....	22
6.4.1 Test Setup .....	22
6.4.2 Test Procedure .....	22
6.5 Conducted Spurious Emissions .....	24
6.5.1 Test Setup .....	24
6.5.2 Test Procedure .....	24
6.6 Radiated Spurious Emissions below 1GHz .....	25
6.6.1 Test Setup .....	25
6.6.2 Test Procedure .....	25
6.7 Radiated Spurious Emissions above 1GHz .....	26
6.7.1 Test Setup .....	26
6.7.2 Test Procedure .....	26
6.8 Frequency Stability .....	27
6.8.1 Test Setup .....	27



6.8.2	Test Procedure .....	27
<b>7</b>	<b>Test Results of Test Item .....</b>	<b>28</b>
7.1	Effective Radiated Power and Equivalent Isotropically Radiated Power .....	28
7.1.1	GSM850 .....	28
7.1.2	GSM1900 .....	29
7.1.3	WCDMA Band 2 .....	30
7.1.4	WCDMA Band 4 .....	31
7.1.5	WCDMA Band 5 .....	32
7.2	Modulation Characteristics .....	33
7.2.1	GSM850 .....	33
7.2.2	GSM1900 .....	34
7.2.3	WCDMA Band 2 .....	35
7.2.4	WCDMA Band 4 .....	36
7.2.5	WCDMA Band 5 .....	37
7.3	Peak to Average Ratio .....	38
7.3.1	GSM850 .....	38
7.3.2	GSM1900 .....	39
7.3.3	WCDMA Band 2 .....	40
7.3.4	WCDMA Band 4 .....	41
7.3.5	WCDMA Band 5 .....	42
7.4	Bandwidth .....	43
7.4.1	GSM850 .....	43
7.4.2	GSM1900 .....	44
7.4.3	WCDMA Band 2 .....	45
7.4.4	WCDMA Band 4 .....	46
7.4.5	WCDMA Band 5 .....	47
7.5	Conducted Spurious Emissions .....	48
7.5.1	GSM850 .....	48
7.5.2	GSM1900 .....	54
7.5.3	WCDMA Band 2 .....	60
7.5.4	WCDMA Band 4 .....	66
7.5.5	WCDMA Band 5 .....	72
7.6	Radiated Spurious Emissions below 1GHz .....	78
7.6.1	GSM 850 .....	78
7.6.2	EDGE 850 .....	80
7.6.3	PCS 1900 .....	82
7.6.4	EDGE 1900 .....	84
7.6.5	WCDMA Band 2 .....	86
7.6.6	WCDMA Band 4 .....	88
7.6.7	WCDMA Band 5 .....	90
7.7	Radiated Spurious Emissions above 1GHz .....	92
7.7.1	GSM 850 .....	92
7.7.2	EDGE 850 .....	95
7.7.3	PCS 1900 .....	98
7.7.4	EDGE 1900 .....	101
7.7.5	WCDMA Band 2 .....	104
7.7.6	WCDMA Band 4 .....	107
7.7.7	WCDMA Band 5 .....	110
7.8	Frequency Stability .....	113
7.8.1	GSM850 .....	113
7.8.2	EDGE850 .....	114
7.8.3	GSM1900 .....	115
7.8.4	EDGE1900 .....	116
7.8.5	WCDMA Band 2 .....	117
7.8.6	WCDMA Band 4 .....	118
7.8.7	WCDMA Band 5 .....	119
<b>8</b>	<b>Pictures of Test Arrangements .....</b>	<b>120</b>
<b>9</b>	<b>Information of the Testing Laboratories .....</b>	<b>121</b>

## Release Control Record

Issue No.	Description	Date Issued
RFBCM-N-WTW-P23100614-7	Original Release	2024/8/14

## 1 Certificate

**Product:** Mobile Computer

**Brand:** CIPHERLAB

**Test Model:** RS38

**Sample Status:** Engineering sample

**Applicant:** Cipherlab Co., Ltd.

**Test Date:** 2024/1/8 ~ 2024/7/19

**Standard:** 47 CFR FCC Part 22  
47 CFR FCC Part 24  
47 CFR FCC Part 27  
47 CFR FCC Part 2

**Measurement** ANSI/TIA/EIA-603-E 2016

**procedure:** ANSI C63.26-2015

KDB 971168 D01 Power Meas License Digital Systems v03r01

KDB 971168 D02 Misc Rev Approv License Devices v02r02

The above equipment has been tested by **Bureau Veritas Consumer Products Services (H.K.) Ltd., Taoyuan Branch**, and found compliance with the requirement of the above standards. The test record, data evaluation & Equipment Under Test (EUT) configurations represented herein are true and accurate accounts of the measurements of the sample's RF characteristics under the conditions specified in this report.

## 2 Summary of Test Results

47 CFR FCC Part 22 47 CFR FCC Part 24 47 CFR FCC Part 27 47 CFR FCC Part 2			
Standard / Clause	Test Item	Result	Remark
FCC 47 CFR Part 2.1046 FCC 47 CFR Part 22.913 (a) FCC 47 CFR Part 24.232 (c) FCC 47 CFR Part 27.50(d)	Effective Radiated Power and Equivalent Isotropically Radiated Power	Pass	Meet the requirement of limit.
FCC 47 CFR Part 2.1047	Modulation Characteristics	Pass	Meet the requirement of limit.
FCC 47 CFR Part 22.913 (d) FCC 47 CFR Part 24.232 (d) FCC 47 CFR Part 27.50(d)	Peak to Average Ratio	Pass	Meet the requirement of limit.
FCC 47 CFR Part 2.1049	Bandwidth	Pass	Meet the requirement of limit.
FCC 47 CFR Part 2.1051 FCC 47 CFR Part 22.917 FCC 47 CFR Part 24.238 FCC 47 CFR Part 27.53(h)	Conducted Spurious Emissions	Pass	Meet the requirement of limit.
FCC 47 CFR Part 2.1053 FCC 47 CFR Part 22.917 FCC 47 CFR Part 24.238 FCC 47 CFR Part 27.53(h)	Radiated Spurious Emissions below 1GHz	Pass	Minimum passing margin is -39.46 dB at 908.82 MHz
FCC 47 CFR Part 2.1053 FCC 47 CFR Part 22.917 FCC 47 CFR Part 24.238 FCC 47 CFR Part 27.53(h)	Radiated Spurious Emissions above 1GHz	Pass	Minimum passing margin is -36.10 dB at 3760.00 MHz
FCC 47 CFR Part 2.1055 FCC 47 CFR Part 22.355 FCC 47 CFR Part 24.235 FCC 47 CFR Part 27.54	Frequency Stability	Pass	Meet the requirement of limit.

Note: Determining compliance based on the results of the compliance measurement, not taking into account measurement instrumentation uncertainty.

## 2.1 Measurement Uncertainty

Where relevant, the following measurement uncertainty levels have been estimated for tests performed on the EUT as specified in CISPR 16-4-2:

Parameter	Specification	Uncertainty (±)
Maximum Output Power / Peak to Average Ratio	-	1.371 dB
26dB Bandwidth / Occupied Bandwidth	-	453.93 Hz / 72 Hz
Conducted emission / Spectrum Emission Mask	-	2.120 dB / 1.899 dB
Frequency Stability	-	0.176 ppm
Radiated Spurious Emissions below 1GHz	9 kHz ~ 30 MHz	3.00 dB
	30 MHz ~ 1 GHz	2.93 dB
Radiated Spurious Emissions above 1GHz	1 GHz ~ 18 GHz	1.76 dB
	18 GHz ~ 40 GHz	1.77 dB

The other instruments specified are routine verified to remain within the calibrated levels, no measurement uncertainty is required to be calculated.

## 2.2 Supplementary Information

There is not any deviation from the test standards for the test method, and no modifications required for compliance.

### 3 General Information

#### 3.1 General Description of EUT

Product	Mobile Computer
Brand	CIPHERLAB
Test Model	RS38
Status of EUT	Engineering sample
Power Supply Rating	3.87 Vdc (from battery) 5 Vdc (from adapter or host equipment)

Note:

##### 1. EUT Overview

Band / Bandwidth	TX Frequency Range (MHz)	Max. EIRP Power
GSM1900	1850.2-1909.8	561.048mW (27.49dBm)
WCDMA Band 2	1852.4-1907.6	164.816mW (22.17dBm)
WCDMA Band 4	1712.4-1752.6	166.341mW (22.21dBm)

Band / Bandwidth	TX Frequency Range (MHz)	Max. ERP Power
GSM850	824.2-848.8	1004.616mW (30.02dBm)
WCDMA Band 5	826.4-846.6	87.498mW (19.42dBm)

Band / Bandwidth	TX Frequency Range (MHz)	Emission Designator
GSM850	824.2-848.8	247KGXW
GPRS850	824.2-848.8	247KGXW
EDGE850	824.2-848.8	248KG7W
GSM1900	1850.2-1909.8	248KGXW
GPRS1900	1850.2-1909.8	247KGXW
EDGE1900	1850.2-1909.8	248KG7W
WCDMA Band 2	1852.4-1907.6	4M17F9W
WCDMA Band 4	1712.4-1752.6	4M17F9W
WCDMA Band 5	826.4-846.6	4M16F9W

##### 2. The EUT uses following accessories.

Item	Brand	Model	Specification
Adapter	Channel WELL Technology	2AEA010BC3D	AC Input: 100-240 Vac, 50/60 Hz, 0.35 A DC Output: 5.0 Vdc, 2.0 A, 10.0 W
Reader 1	Zebra	SE4770	-
Reader 2	Zebra	SE4100	-
Reader 3	Zebra	SE5500	-
1st Battery	CIPHERLAB	BA-0174A5	3.87 Vdc, 4500 mAh, 17.42 Wh
2nd Battery	Chongqing VDL Electronics Co., Ltd	341322PM4	3.85 Vdc, 90 mAh
USB To Type C Cable	SUNCA CO., LTD	1Q11512211-XJ	0.9 m

\* After pretesting, Reader 1 and 1st Battery were the worst case and chosen for final test.

3. The above EUT information is declared by manufacturer and for more detailed features description, please refers to the manufacturer's specifications or user's manual.



### 3.2 Antenna Description of EUT

1. The antenna information is listed as below.

Antenna Type	LDS		
Antenna Connector	spring		
Item	Band	Freq. Range (MHz)	Gain (dBi)
			Ant. 0
GSM	850	824~849	-2
	1900	1850~1910	-1.5
WCDMA	Band 2	1850~1910	-1.5
	Band 4	1710~1755	-1.5
	Band 5	824~849	-2

\*The above Antenna information is declared by manufacturer and for more detailed features description, please refer to the manufacturer's specifications, the laboratory shall not be held responsible.

### 3.3 Test Mode Applicability and Tested Channel Detail

Pre-Scan:	EUT can be used in the following ways: X-axis/ Y-axis/ Z-axis. Pre-scan these ways and find the worst case as a representative test condition.
Worst Case:	X-axis/ Y-axis/ Z-axis Worst Condition: Z-axis

#### For GSM850

Test Item	Tested Channel	Mode
ERP	128 (824.20 MHz) 189 (836.40 MHz) 251 (848.80 MHz)	GSM, GPRS, EDGE
Modulation Characteristics	189 (836.40 MHz)	GSM, GPRS, EDGE
Frequency Stability	128 (824.20 MHz) 251 (848.80 MHz)	GSM, EDGE
Occupied Bandwidth	128 (824.20 MHz) 189 (836.40 MHz) 251 (848.80 MHz)	GSM, GPRS, EDGE
Peak to Average Ratio	128 (824.20 MHz) 189 (836.40 MHz) 251 (848.80 MHz)	GSM, GPRS, EDGE
Conducted Emission	128 (824.20 MHz) 189 (836.40 MHz) 251 (848.80 MHz)	GSM, GPRS, EDGE
Radiated Spurious Emissions below 1GHz	189 (836.40 MHz)	GSM, EDGE
Radiated Spurious Emissions above 1GHz	128 (824.20 MHz) 189 (836.40 MHz) 251 (848.80 MHz)	GSM, EDGE

#### For PCS1900

Test Item	Tested Channel	Mode
EIRP	512 (1850.20 MHz) 661 (1880.00 MHz) 810 (1909.80 MHz)	GSM, GPRS, EDGE
Modulation Characteristics	661 (1880.00 MHz)	GSM, GPRS, EDGE
Frequency Stability	512 (1850.20 MHz) 810 (1909.80 MHz)	GSM, EDGE
Occupied Bandwidth	512 (1850.20 MHz) 661 (1880.00 MHz) 810 (1909.80 MHz)	GSM, GPRS, EDGE
Peak to Average Ratio	512 (1850.20 MHz) 661 (1880.00 MHz) 810 (1909.80 MHz)	GSM, GPRS, EDGE
Conducted Emission	512 (1850.20 MHz) 661 (1880.00 MHz) 810 (1909.80 MHz)	GSM, GPRS, EDGE
Radiated Spurious Emissions below 1GHz	661 (1880.00 MHz)	GSM, EDGE
Radiated Spurious Emissions above 1GHz	512 (1850.20 MHz) 661 (1880.00 MHz) 810 (1909.80 MHz)	GSM, EDGE

#### For WCDMA Band 2

Test Item	Tested Channel	Mode
EIRP	9262 (1852.40 MHz)	WCDMA
	9400 (1880.00 MHz)	HSDPA
	9538 (1907.60 MHz)	HSUPA
Modulation Characteristics	9400 (1880.00 MHz)	WCDMA
		HSDPA
		HSUPA
Frequency Stability	9262 (1852.40 MHz)	WCDMA
	9538 (1907.60 MHz)	
Occupied Bandwidth	9262 (1852.40 MHz)	WCDMA
	9400 (1880.00 MHz)	HSDPA
	9538 (1907.60 MHz)	HSUPA
Peak to Average Ratio	9262 (1852.40 MHz)	WCDMA
	9400 (1880.00 MHz)	HSDPA
	9538 (1907.60 MHz)	HSUPA
Conducted Emission	9262 (1852.40 MHz)	WCDMA
	9400 (1880.00 MHz)	HSDPA
	9538 (1907.60 MHz)	HSUPA
Radiated Spurious Emissions below 1GHz	9400 (1880.00 MHz)	WCDMA
Radiated Spurious Emissions above 1GHz	9262 (1852.40 MHz)	WCDMA
	9400 (1880.00 MHz)	
	9538 (1907.60 MHz)	

#### For WCDMA Band 4

Test Item	Tested Channel	Mode
EIRP	1312 (1712.40 MHz)	WCDMA
	1413 (1732.60 MHz)	HSDPA
	1513 (1752.60 MHz)	HSUPA
Modulation Characteristics	1413 (1732.60 MHz)	WCDMA
		HSDPA
		HSUPA
Frequency Stability	1312 (1712.40 MHz)	WCDMA
	1513 (1752.60 MHz)	
Occupied Bandwidth	1312 (1712.40 MHz)	WCDMA
	1413 (1732.60 MHz)	HSDPA
	1513 (1752.60 MHz)	HSUPA
Peak to Average Ratio	1312 (1712.40 MHz)	WCDMA
	1413 (1732.60 MHz)	HSDPA
	1513 (1752.60 MHz)	HSUPA
Conducted Emission	1312 (1712.40 MHz)	WCDMA
	1413 (1732.60 MHz)	HSDPA
	1513 (1752.60 MHz)	HSUPA
Radiated Spurious Emissions below 1GHz	1413 (1732.60 MHz)	WCDMA
Radiated Spurious Emissions above 1GHz	1312 (1712.40 MHz)	WCDMA
	1413 (1732.60 MHz)	
	1513 (1752.60 MHz)	

For WCDMA Band 5

Test Item	Tested Channel	Mode
ERP	4132 (826.40 MHz) 4182 (836.40 MHz) 4233 (846.60 MHz)	WCDMA HSDPA HSUPA
Modulation Characteristics	4182 (836.40 MHz)	WCDMA HSDPA HSUPA
Frequency Stability	4132 (826.40 MHz) 4233 (846.60 MHz)	WCDMA
Occupied Bandwidth	4132 (826.40 MHz) 4182 (836.40 MHz) 4233 (846.60 MHz)	WCDMA HSDPA HSUPA
Peak to Average Ratio	4132 (826.40 MHz) 4182 (836.40 MHz) 4233 (846.60 MHz)	WCDMA HSDPA HSUPA
Conducted Emission	4132 (826.40 MHz) 4182 (836.40 MHz) 4233 (846.60 MHz)	WCDMA HSDPA HSUPA
Radiated Spurious Emissions below 1GHz	4182 (836.40 MHz)	WCDMA
Radiated Spurious Emissions above 1GHz	4132 (826.40 MHz) 4182 (836.40 MHz) 4233 (846.60 MHz)	WCDMA

### 3.4 Test Program Used and Operation Descriptions

There is no need to controlling software during the test, and the EUT can be paired with the Radio Communication Analyzer to test the connection when it is powered on.

### 3.5 Connection Diagram of EUT and Peripheral Devices

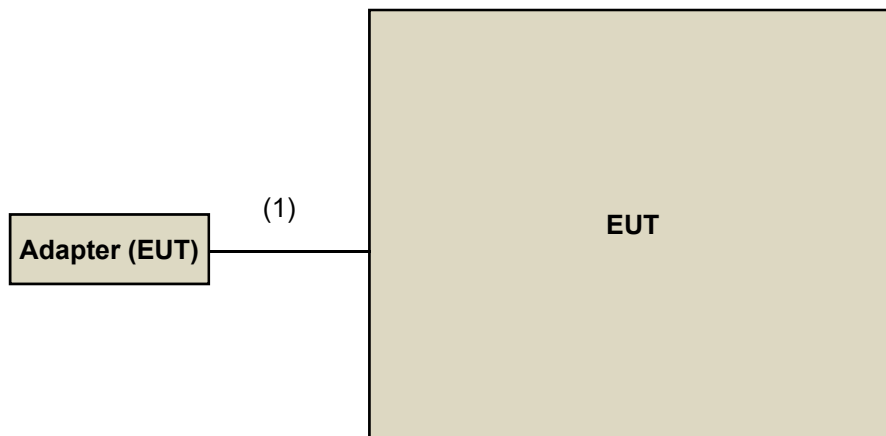

-----

**Under Table**

-----

**Remote Site**



Radio  
Communication  
Analyzer (A)

### 3.6 Configuration of Peripheral Devices and Cable Connections

ID	Product	Brand	Model No.	Serial No.	FCC ID	Remarks
A	Radio Communication Analyzer	Anritsu	MT8821C	6201462755	N/A	Provided by Lab

ID	Cable Descriptions	Qty.	Length (m)	Shielding (Yes/No)	Cores (Qty.)	Remarks
1	USB To Type C Cable	1	0.9	Y	0	Accessory of EUT

## 4 Test Instruments

The calibration interval of the all test instruments are 12 months and the calibrations are traceable to NML/ROC and NIST/USA.

### 4.1 Effective Radiated Power and Equivalent Isotropically Radiated Power

Description Manufacturer	Model No.	Serial No.	Calibrated Date	Calibrated Until
N9030B - PXA Signal Analyzer KEYSIGHT	N9030B	MY57140488	2024/3/6	2025/3/5
Radio Communication Analyzer Anritsu	MT8821C	6201462755	2024/3/13	2025/3/12
Software BV	ADT_RF Test Software V6.6.5.4	N/A	N/A	N/A

Notes:

1. The test was performed in Oven room.
2. Tested Date: 2024/7/19

### 4.2 Modulation Characteristics

Description Manufacturer	Model No.	Serial No.	Calibrated Date	Calibrated Until
N9030B - PXA Signal Analyzer KEYSIGHT	N9030B	MY57140938	2023/3/16	2024/3/15
Radio Communication Analyzer Anritsu	MT8821C	6201462755	2023/3/3	2024/3/2
Software BV	ADT_RF Test Software V6.6.5.4	N/A	N/A	N/A

Notes:

1. The test was performed in Oven room.
2. Tested Date: 2024/2/2 ~ 2024/2/5

### 4.3 Peak to Average Ratio

Refer to section 4.2 to get information of the instruments.

### 4.4 Bandwidth

Refer to section 4.2 to get information of the instruments.

### 4.5 Conducted Spurious Emissions

Refer to section 4.2 to get information of the instruments.

#### 4.6 Radiated Spurious Emissions below 1GHz

Description Manufacturer	Model No.	Serial No.	Calibrated Date	Calibrated Until
Antenna Tower Max-Full	MFT-151SS-0.5T	N/A	N/A	N/A
Bi_Log Antenna Schwarzbeck	VULB 9168	9168-1213	2023/10/13	2024/10/12
EMI Test Receiver R&S	ESR3	102782	2023/12/7	2024/12/6
Loop Antenna Electro-Metrics	EM-6879	269	2023/9/23	2024/9/22
Loop Antenna TESEQ	HLA 6121	45745	2023/8/8	2024/8/7
MXA Signal Analyzer Keysight	N9020B	MY60110513	2023/12/22	2024/12/21
Preamplifier EMCI	EMC330N	980782	2024/1/15	2025/1/14
	EMC001340	980201	2023/9/27	2024/9/26
RF Coaxial Cable EMCI	EMCCFD400-NM-NM- 500	201233	2024/1/15	2025/1/14
	EMCCFD400-NM-NM- 3000	201235	2024/1/15	2025/1/14
	EMCCFD400-NM-NM- 9000	201236(with PAD)	2024/1/15	2025/1/14
Software BV ADT	ADT_Radiated_ V7.6.15.9.5	N/A	N/A	N/A
Turn Table Max-Full	MF-7802BS	N/A	N/A	N/A
Turn Table Controller Max-Full	MF-7802BS	MF780208674	N/A	N/A
Radio Communication Analyzer Anritsu	MT8821C	6201462755	2023/3/3 2024/3/13	2024/3/2 2025/3/12

Notes:

1. The test was performed in WM - 966 chamber 8.
2. Tested Date: 2024/1/15 ~ 2024/7/18

#### 4.7 Radiated Spurious Emissions above 1GHz

Description Manufacturer	Model No.	Serial No.	Calibrated Date	Calibrated Until
Antenna Tower Max-Full	MFT-151SS-0.5T	N/A	N/A	N/A
EMI Test Receiver R&S	ESR3	102782	2023/12/7	2024/12/6
Horn Antenna RFSPIN	DRH18-E	210103A18E	2023/11/12	2024/11/11
MXA Signal Analyzer Keysight	N9020B	MY60110513	2023/12/22	2024/12/21
Preamplifier EMCI	EMC118A45SE	980808	2023/12/28	2024/12/27
RF Coaxial Cable EMCI	EMC104-SM-SM-1000	210102	2024/1/15	2025/1/14
	EMC104-SM-SM-3000	201231	2024/1/15	2025/1/14
	EMC104-SM-SM-9000	201243	2024/1/15	2025/1/14
Software BV ADT	ADT_Radiated_ V7.6.15.9.5	N/A	N/A	N/A
Turn Table Max-Full	MF-7802BS	N/A	N/A	N/A
Turn Table Controller Max-Full	MF-7802BS	MF780208674	N/A	N/A
Radio Communication Analyzer Anritsu	MT8821C	6201462755	2023/3/3 2024/3/13	2024/3/2 2025/3/12

Notes:

1. The test was performed in WM - 966 chamber 8.
2. Tested Date: 2024/1/15 ~ 2024/7/18



#### 4.8 Frequency Stability

Description Manufacturer	Model No.	Serial No.	Calibrated Date	Calibrated Until
3-channel DC power supply JIN YIH Technology	ODP3033	ODP30332128138	N/A	N/A
Digital Multimeter Fluke	87-III	70360742	2023/7/6	2024/7/5
Signal and spectrum analyzer R&S	FSV3044	101105	2024/2/27	2025/2/26
Software BV	ADT_RF Test Software V6.6.5.4	N/A	N/A	N/A
Temperature & Humidity Chamber TERCHY	HRM-120RF	931022	2023/12/19	2024/12/18
Radio Communication Analyzer Anritsu	MT8821C	6201462755	2024/3/13	2025/3/12

Notes:

1. The test was performed in Oven room.
2. Tested Date: 2024/4/8

## 5 Limits of Test Items

### 5.1 Effective Radiated Power and Equivalent Isotropically Radiated Power

#### For GSM1900, WCDMA Band 2:

Mobile and portable stations are limited to 2 watts EIRP.

#### For WCDMA Band 4:

Fixed, mobile, and portable (hand-held) stations operating in the 1710-1755 MHz band and mobile and portable stations operating in the 1695-1710 MHz and 1755-1780 MHz bands are limited to 1 watt EIRP.

#### For GSM850, WCDMA Band 5:

The ERP of mobile transmitters and auxiliary test transmitters must not exceed 7 watts.

### 5.2 Modulation Characteristics

A curve or equivalent data which shows that the equipment will meet the modulation requirements of the rules under which the equipment is to be licensed.

### 5.3 Peak to Average Ratio

In measuring transmissions in this band using an average power technique, the peak to-average ratio (PAR) of the transmission may not exceed 13 dB.

### 5.4 Bandwidth

According to FCC 47 CFR part 2.1049, the occupied bandwidth, that is the frequency bandwidth such that, below its lower and above its upper frequency limits, the mean powers radiated are each equal to 0.5% of the total mean power radiated by a given emission.

### 5.5 Conducted Spurious Emissions

#### For GSM850, GSM1900, WCDMA Band 2, WCDMA Band 5:

The power of any emission outside of the authorized operating frequency ranges must be attenuated below the transmitting power (P) by a factor of at least  $43 + 10 \log(P)$  dB. The emission limit equal to  $-13$  dBm.

#### For WCDMA Band 4:

According to FCC 47 CFR part 27.53(h), for operations in the 1695-1710 MHz, 1710-1755 MHz, 1755-1780 MHz, 1915-1920 MHz, 1995-2000 MHz, 2000-2020 MHz, 2110-2155 MHz, 2155-2180 MHz, and 2180-2200 MHz bands, the power of any emission outside a licensee's frequency block shall be attenuated below the transmitter power (P) in watts by at least  $43 + 10 \log(P)$  dB. However, in the 1 megahertz bands immediately outside and adjacent to the licensee's frequency block, a resolution bandwidth of at least one percent of the emission bandwidth of the fundamental emission of the transmitter may be employed.

## 5.6 Radiated Spurious Emissions below 1GHz

### For GSM850, GSM1900, WCDMA Band 2, WCDMA Band 5:

The power of any emission outside of the authorized operating frequency ranges must be attenuated below the transmitting power (P) by a factor of at least  $43 + 10 \log(P)$  dB. The emission limit equal to  $-13$  dBm.

### For WCDMA Band 4:

According to FCC 47 CFR part 27.53(h), for operations in the 1695-1710 MHz, 1710-1755 MHz, 1755-1780 MHz bands, the power of any emission outside a licensee's frequency block shall be attenuated below the transmitter power (P) in watts by at least  $43 + 10 \log(P)$  dB. The limit of emission is equal to  $-13$  dBm.

## 5.7 Radiated Spurious Emissions above 1GHz

### For GSM850, GSM1900, WCDMA Band 2, WCDMA Band 5:

The power of any emission outside of the authorized operating frequency ranges must be attenuated below the transmitting power (P) by a factor of at least  $43 + 10 \log(P)$  dB. The emission limit equal to  $-13$  dBm.

### For WCDMA Band 4:

According to FCC 47 CFR part 27.53(h), for operations in the 1695-1710 MHz, 1710-1755 MHz, 1755-1780 MHz bands, the power of any emission outside a licensee's frequency block shall be attenuated below the transmitter power (P) in watts by at least  $43 + 10 \log(P)$  dB. The limit of emission is equal to  $-13$  dBm.

## 5.8 Frequency Stability

### For GSM850, WCDMA Band 5:

1.5 ppm is for base and fixed station. 2.5 ppm is for mobile station.

### For GSM1900, WCDMA Band 2, WCDMA Band 4:

The frequency stability shall be sufficient to ensure that the fundamental emissions stay within the authorized bands of operation (authorized frequency block).

## 6 Test Arrangements

### 6.1 Effective Radiated Power and Equivalent Isotropically Radiated Power

#### 6.1.1 Test Setup

##### Conducted Power Measurement:

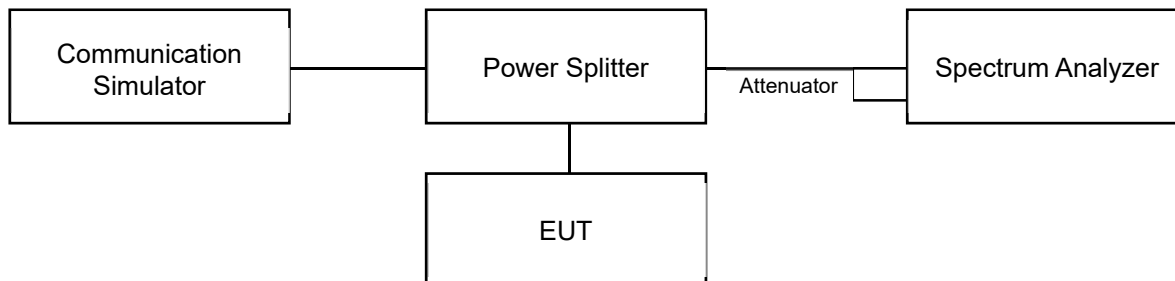

#### 6.1.2 Test Procedure

##### Conducted Power Measurement:

The EUT is configured by emulator to set data modulation and maximum power using WWAN technology. The average (rms) power measurement was performed on emulator and power value was measured from power function on emulator. Set the EUT to transmit under low, middle and high channel and record the power level shown on simulator.

##### Maximum EIRP / ERP

The relevant equation for determining the maximum ERP or EIRP from the measured RF output power is given in Equation as follows:

$$\text{EIRP} = P_{\text{Meas}} + G_{\text{T}}$$

$$\text{ERP} = P_{\text{Meas}} + G_{\text{T}} - 2.15$$

where

ERP or EIRP effective radiated power or equivalent isotropically radiated power, respectively

(expressed in the same units as  $P_{\text{Meas}}$ , e.g., dBm or dBW)

$P_{\text{Meas}}$  measured transmitter output power or PSD, in dBm or dBW

$G_{\text{T}}$  gain of the transmitting antenna, in dBd (ERP) or dBi (EIRP)

## 6.2 Modulation Characteristics

### 6.2.1 Test Setup

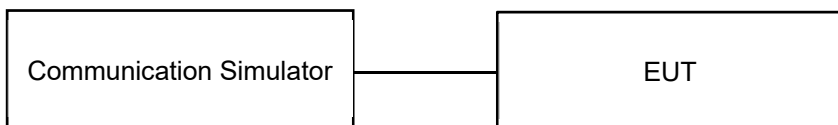

### 6.2.2 Test Procedure

Connect the EUT to Communication Simulator via the antenna connector, the frequency band is set as EUT supported Modulation and Channels, the EUT output is matched with 50 ohm load, the waveform quality and constellation of the EUT was tested.

## 6.3 Peak to Average Ratio

### 6.3.1 Test Setup

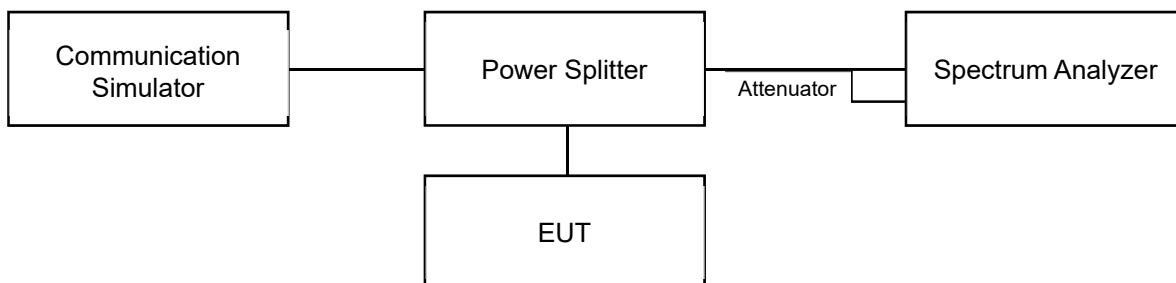

### 6.3.2 Test Procedure

- a. Set resolution/measurement bandwidth  $\geq$  signal's occupied bandwidth;
- b. Set the number of counts to a value that stabilizes the measured CCDF curve;
- c. Record the maximum PAPR level associated with a probability of 0.1%.

## 6.4 Bandwidth

### 6.4.1 Test Setup

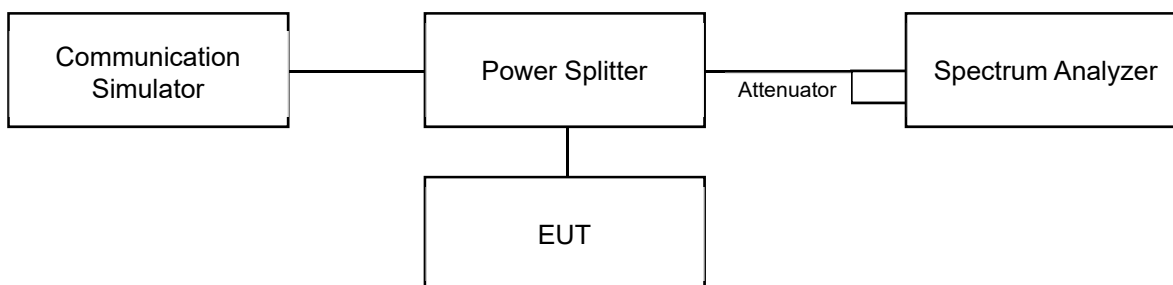

### 6.4.2 Test Procedure

For the 26 dBc bandwidth measurement method, please refer to section 5.4.3 of ANSI C63.26.

- a. The spectrum analyzer center frequency is set to the nominal EUT channel center frequency. The span range for the spectrum analyzer shall be wide enough to see sufficient roll off of the signal to make the measurement.
- b. The nominal RBW shall be in the range of 1% to 5% of the anticipated OBW, and the VBW shall be set  $\geq 3 \times$  RBW.
- c. Set the reference level of the instrument as required to prevent the signal amplitude from exceeding the maximum spectrum analyzer input mixer level for linear operation. See guidance provided in 4.2.3.
- d. The dynamic range of the spectrum analyzer at the selected RBW shall be more than 10 dB below the target “-X dB” requirement, i.e., if the requirement calls for measuring the -26 dB OBW, the spectrum analyzer noise floor at the selected RBW shall be at least 36 dB below the reference level.
- e. Set spectrum analyzer detection mode to peak, and the trace mode to max hold.
- f. Determine the following reference values: Set the EUT to transmit a modulated signal. Allow the trace to stabilize. Set the spectrum analyzer marker to the highest level of the displayed trace (this is the reference value).
- g. Determine the “-X dB amplitude” as equal to (Reference Value - X). Alternatively, this calculation can be performed on the spectrum analyzer using the delta-marker measurement function.
- h. Place two markers, one at the lowest and the other at the highest frequency of the envelope of the spectral display such that each marker is at or slightly below the “-X dB amplitude” determined in step f). If a marker is below this “-X dB amplitude” value it should be as close as possible to this value. The OBW is the positive frequency difference between the two markers.
- i. The OBW shall be reported by providing plot(s) of the measuring instrument display, to include markers depicting the relevant frequency and amplitude information (e.g., marker table). The frequency and amplitude axis and scale shall be clearly labeled. Tabular data may be reported in addition to the plot(s).

For the occupied bandwidth measurement method, please refer to section 5.4.4 of ANSI C63.26.

- a. The spectrum analyzer center frequency is set to the nominal EUT channel center frequency. The span range for the spectrum analyzer shall be wide enough to see sufficient roll off of the signal to make the measurement.
- b. The nominal RBW shall be in the range of 1% to 5% of the anticipated OBW, and the VBW shall be set  $\geq 3 \times$  RBW.
- c. Set the reference level of the instrument as required to prevent the signal amplitude from exceeding the maximum spectrum analyzer input mixer level for linear operation. See guidance provided in 4.2.3.
- d. The dynamic range of the spectrum analyzer at the selected RBW shall be more than 10 dB below the target “-X dB” requirement, i.e., if the requirement calls for measuring the -26 dB OBW, the spectrum analyzer noise floor at the selected RBW shall be at least 36 dB below the reference level.
- e. Set spectrum analyzer detection mode to peak, and the trace mode to max hold.
- f. Determine the reference value by either of the following:
  - g. 1) Set the EUT to transmit a modulated signal. Allow the trace to stabilize. Set the spectrum analyzer marker to the highest level of the displayed trace (this is the reference value).
  - h. 2) Set the EUT to transmit an unmodulated carrier. Set the spectrum analyzer marker to the level of the carrier.
- i. Determine the “-X dB amplitude” as equal to (Reference Value - X). Alternatively, this calculation can be performed on the spectrum analyzer using the delta-marker measurement function.
- j. If the reference value was determined using an unmodulated carrier, turn the EUT modulation on, then either clear the existing trace or start a new trace on the spectrum analyzer and allow the new trace to stabilize. Otherwise the trace from step f) shall be used for step i).
- k. Place two markers, one at the lowest and the other at the highest frequency of the envelope of the spectral display such that each marker is at or slightly below the “-X dB amplitude” determined in step f). If a marker is below this “-X dB amplitude” value it should be as close as possible to this value. The OBW is the positive frequency difference between the two markers. The spectral envelope can cross the “-X dB amplitude” at multiple points. The lowest or highest frequency shall be selected as the frequencies that are the farthest away from the center frequency at which the spectral envelope crosses the “-X dB amplitude.”
- l. The OBW shall be reported by providing plot(s) of the measuring instrument display, to include markers depicting the relevant frequency and amplitude information (e.g., marker table). The frequency and amplitude axis and scale shall be clearly labeled. Tabular data may be reported in addition to the plot(s).

## 6.5 Conducted Spurious Emissions

### 6.5.1 Test Setup

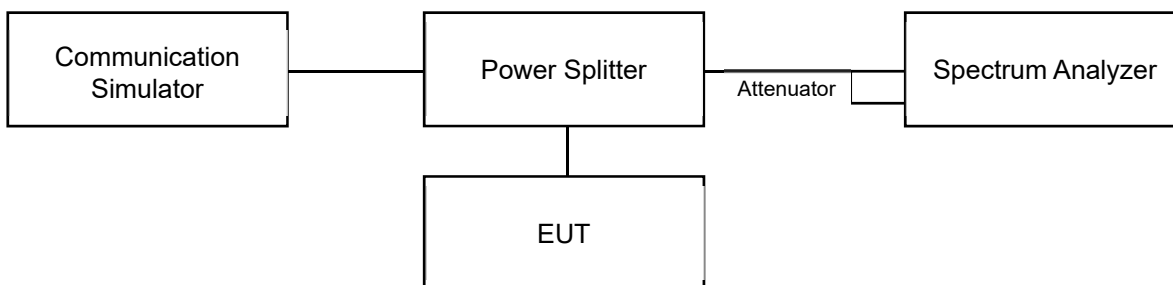

### 6.5.2 Test Procedure

- a. Measurement refer to ANSI C63.26 section 5.7.
- b. All measurements were done at 3 channels: low, middle and high operational frequency range.
- c. Measuring frequency range is from 9 kHz up to the tenth harmonic of the highest fundamental frequency or to 40 GHz, whichever is lower. 20 dB attenuation pad is connected with spectrum.
- d. The fundamental frequency above 1 GHz, the spectrum set RBW = 1 MHz, VBW = 3 MHz, Detector = Average.
- e. The fundamental frequency below 1 GHz, the spectrum set RBW  $\geq$  100 kHz, VBW  $\geq$  3 x RBW, Detector = Average.
- f. Measuring frequency band edge, narrow RBW (no less than 1% of the OBW) is used for conducted emission measurement.



## 6.6 Radiated Spurious Emissions below 1GHz

### 6.6.1 Test Setup

#### For radiated emission 30 MHz to 1 GHz

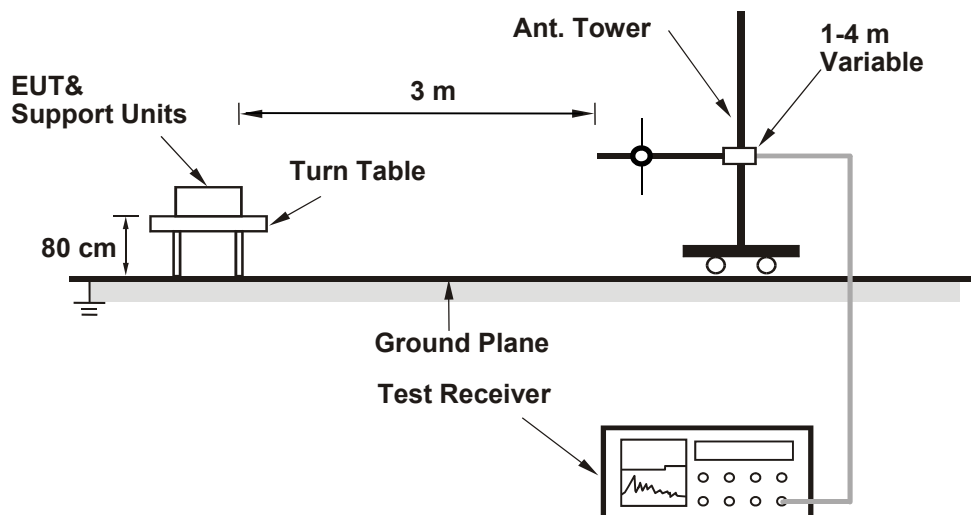

For the actual test configuration, please refer to the attached file (Test Setup Photo).

### 6.6.2 Test Procedure

The EUT is configured by emulator to set data modulation and maximum power using WWAN technology.

- In the semi-anechoic chamber, EUT placed on the 0.8 m (below or equal 1 GHz) height of turn table, rotated the table around 360 degrees to search the maximum radiation power and receiver antenna shall be rotated vertical and horizontal polarization and moved height from 1 m to 4 m to find the maximum polar radiated power. The "Read Value" is the spectrum reading the maximum power value.
- The height of antenna is varied from one meter to four meters above the ground to determine the maximum value of the field strength. Both horizontal and vertical polarizations of the antenna are set to make the measurement.
- Perform a field strength measurement and record the worse read value, is the field strength value via a spectrum reading obtained corrected for antenna factor, cable loss and pre-amplifier factor and then mathematically convert the measured field strength level to EIRP/ERP level.
- Following C63.26 section 5.5 and 5.2.7
- $EIRP (dBm) = E (dB\mu V/m) + 20\log(D) - 104.8$ ; where D is the measurement distance (in the far field region) in m.
- $ERP (dBm) = E (dB\mu V/m) + 20\log(D) - 104.8 - 2.15$ ; where D is the measurement distance (in the far field region) in m.

#### Note:

- The resolution bandwidth and video bandwidth of test receiver/spectrum analyzer is 1 MHz/3 MHz. Set detector=average.
- The emission levels were against the limit of frequency range 9 kHz ~ 30 MHz:  
The amplitude of spurious emissions attenuated more than 20 dB below the permissible value is not required to be report.

## 6.7 Radiated Spurious Emissions above 1GHz

### 6.7.1 Test Setup

#### For radiated emission above 1 GHz

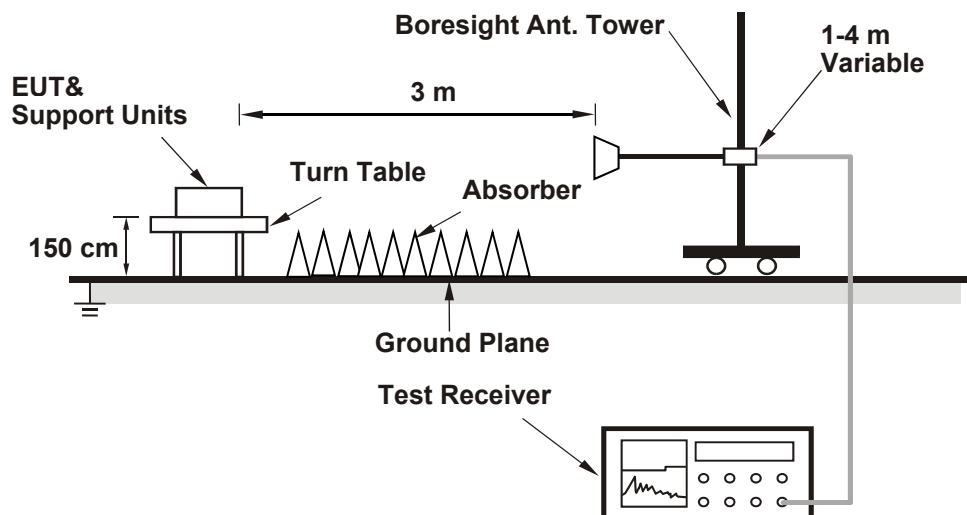

For the actual test configuration, please refer to the attached file (Test Setup Photo).

### 6.7.2 Test Procedure

The EUT is configured by emulator to set data modulation and maximum power using WWAN technology.

- In the semi-anechoic chamber, EUT placed on the 1.5 m height of turn table, rotated the table around 360 degrees to search the maximum radiation power and receiver antenna shall be rotated vertical and horizontal polarization and moved height from 1 m to 4 m to find the maximum polar radiated power. The "Read Value" is the spectrum reading the maximum power value.
- The height of antenna is varied from one meter to four meters above the ground to determine the maximum value of the field strength. Both horizontal and vertical polarizations of the antenna are set to make the measurement.
- Perform a field strength measurement and record the worse read value, is the field strength value via a spectrum reading obtained corrected for antenna factor, cable loss and pre-amplifier factor and then mathematically convert the measured field strength level to EIRP/ERP level.
- Following C63.26 section 5.5 and 5.2.7
- $EIRP (dBm) = E (dB\mu V/m) + 20\log(D) - 104.8$ ; where D is the measurement distance (in the far field region) in m.
- $ERP (dBm) = E (dB\mu V/m) + 20\log(D) - 104.8 - 2.15$ ; where D is the measurement distance (in the far field region) in m.

#### Note:

- The resolution bandwidth and video bandwidth of test receiver/spectrum analyzer is 1 MHz/3 MHz. Set detector=average.

## 6.8 Frequency Stability

### 6.8.1 Test Setup

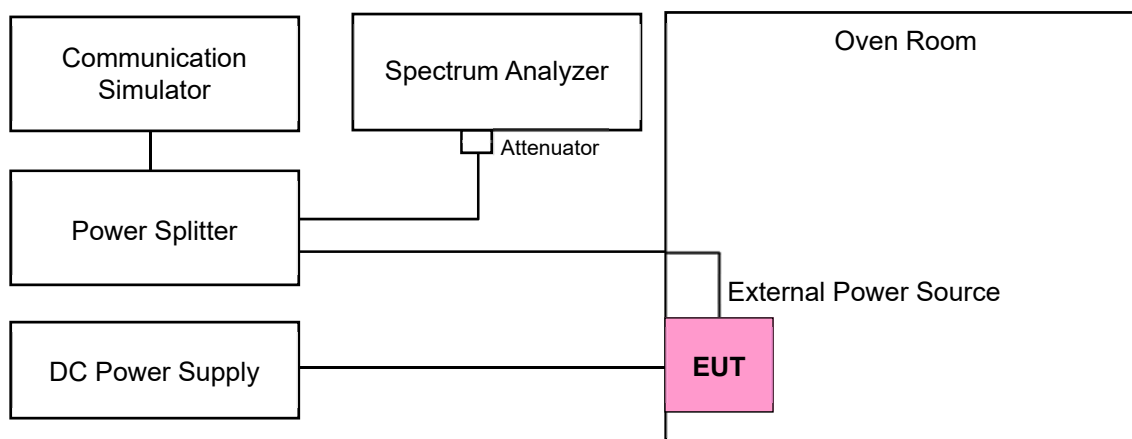

### 6.8.2 Test Procedure

The EUT is configured by emulator to set data modulation and maximum power using WWAN technology.

- Device is placed at the oven room. The oven room could control the temperatures and humidity. Power warm up is at least 15 min and power applied should perform before recording frequency error.
- EUT is connected the external power supply to control the DC input power. The test voltage range is from minimum to maximum working voltage. Each step shall be record the frequency error rate.
- The temperature range step is 10 degrees in this test items. All temperature levels shall be hold the  $\pm 0.5^{\circ}\text{C}$  during the measurement testing. The each temperature step shall be at least 0.5 hours, consider the EUT could be test under the stability condition.

Note: The frequency error was recorded frequency error from the communication simulator.

## 7 Test Results of Test Item

### 7.1 Effective Radiated Power and Equivalent Isotropically Radiated Power

Input Power:	3.87 Vdc	Environmental Conditions:	22°C, 65% RH	Tested By:	Willy Cheng
--------------	----------	---------------------------	--------------	------------	-------------

#### 7.1.1 GSM850

##### Conducted Output Power (dBm)

Band	GSM850		
	128	189	251
Channel	128	189	251
Frequency (MHz)	824.2	836.4	848.8
GSM	34.17	32.69	34.06
GPRS 1Tx Slot	34.02	32.54	33.91
GPRS 2Tx Slot	33.98	32.5	33.87
GPRS 3Tx Slot	33.97	32.49	33.86
GPRS 4Tx Slot	33.88	32.4	33.77
DTM 9 (GPRS)	29.21	27.73	29.10
DTM 11 (GPRS)	27.51	26.03	27.40
EDGE 1Tx Slot (MCS9)	26.49	25.01	26.38
EDGE 2Tx Slot (MCS9)	23.89	22.41	23.78
EDGE 3Tx Slot (MCS9)	21.93	20.45	21.82
EDGE 4Tx Slot (MCS9)	20.41	18.93	20.3
DTM 9 (EDGE)	23.28	21.80	23.17
DTM 11 (EDGE)	11.24	9.76	11.13

##### ERP Power (dBm)

Maximum Output Power		
Modulation	Cond. Power (dBm)	ERP (dBm)
GPRS	34.17	30.02
EDGE	26.49	22.34

Note: EIRP (dBm) = Cond. Power (dBm) + Antenna Gain (dBi) + Array Gain (if applicable)

ERP (dBm) = EIRP (dBm) - 2.15

**7.1.2 GSM1900**
**Conducted Output Power (dBm)**

Band	GSM1900		
	512	661	810
Channel	512	661	810
Frequency (MHz)	1850.2	1880	1909.8
GSM	28.99	28.96	28.94
GPRS 1Tx Slot	28.89	28.86	28.84
GPRS 2Tx Slot	28.86	28.83	28.81
GPRS 3Tx Slot	28.83	28.8	28.78
GPRS 4Tx Slot	28.81	28.78	28.76
DTM 9 (GPRS)	26.51	26.48	26.46
DTM 11 (GPRS)	24.36	24.33	24.31
EDGE 1Tx Slot (MCS9)	25.16	25.13	25.11
EDGE 2Tx Slot (MCS9)	22.38	22.35	22.33
EDGE 3Tx Slot (MCS9)	20.23	20.2	20.18
EDGE 4Tx Slot (MCS9)	18.75	18.72	18.7
DTM 9 (EDGE)	22.49	22.46	22.44
DTM 11 (EDGE)	20.49	20.46	20.44

**EIRP Power (dBm)**

Maximum Output Power		
Modulation	Cond. Power (dBm)	EIRP (dBm)
GPRS	28.99	27.49
EDGE	25.16	23.66

Note: EIRP (dBm) = Cond. Power (dBm) + Antenna Gain (dBi) + Array Gain (if applicable)

### 7.1.3 WCDMA Band 2

#### Conducted Output Power (dBm)

Band	WCDMA II		
TX Channel	9262	9400	9538
Rx Channel	9662	9800	9938
Frequency	1852.4	1880	1907.6
RMC 12.2K	23.61	23.65	23.67
HSDPA Subtest-1	23.41	23.27	23.12
HSDPA Subtest-2	23.41	23.25	23.15
HSDPA Subtest-3	22.92	22.76	22.69
HSDPA Subtest-4	22.92	22.79	22.64
DC-HSDPA Subtest-1	23.28	23.14	23.02
DC-HSDPA Subtest-2	23.28	23.12	23.02
DC-HSDPA Subtest-3	22.79	22.63	22.56
DC-HSDPA Subtest-4	22.79	22.66	22.51
HSUPA Subtest-1	23.39	23.29	23.10
HSUPA Subtest-2	21.37	21.28	21.12
HSUPA Subtest-3	22.39	22.32	22.19
HSUPA Subtest-4	21.39	21.32	21.16
HSUPA Subtest-5	23.40	23.30	23.10

#### EIRP Power (dBm)

Maximum Output Power		
Modulation	Cond. Power (dBm)	EIRP (dBm)
RMC 12.2K	23.67	22.17
HSDPA	23.41	21.91
HSUPA	23.40	21.90

Note: EIRP (dBm) = Cond. Power (dBm) + Antenna Gain (dBi) + Array Gain (if applicable)

#### 7.1.4 WCDMA Band 4

##### Conducted Output Power (dBm)

Band	WCDMA IV		
TX Channel	1312	1413	1513
Rx Channel	1537	1638	1738
Frequency	1712.4	1732.6	1752.6
RMC 12.2K	23.71	23.66	23.56
HSDPA Subtest-1	23.30	23.30	23.22
HSDPA Subtest-2	23.29	23.29	23.23
HSDPA Subtest-3	22.85	22.80	22.70
HSDPA Subtest-4	22.56	22.84	22.71
DC-HSDPA Subtest-1	23.17	23.17	23.09
DC-HSDPA Subtest-2	23.16	23.16	23.10
DC-HSDPA Subtest-3	22.72	22.67	22.57
DC-HSDPA Subtest-4	22.52	22.71	22.58
HSUPA Subtest-1	23.31	23.26	23.05
HSUPA Subtest-2	21.28	22.30	21.13
HSUPA Subtest-3	22.25	22.82	22.22
HSUPA Subtest-4	21.22	21.18	21.20
HSUPA Subtest-5	23.25	23.21	23.23

##### EIRP Power (dBm)

Maximum Output Power		
Modulation	Cond. Power (dBm)	EIRP (dBm)
RMC 12.2K	23.71	22.21
HSDPA	23.30	21.80
HSUPA	23.31	21.81

Note: EIRP (dBm) = Cond. Power (dBm) + Antenna Gain (dBi) + Array Gain (if applicable)

**7.1.5 WCDMA Band 5**
**Conducted Output Power (dBm)**

Band	WCDMA V		
TX Channel	4132	4182	4233
Rx Channel	4357	4407	4458
Frequency	826.4	836.4	846.6
RMC 12.2K	23.49	23.57	23.45
HSDPA Subtest-1	23.23	23.29	23.21
HSDPA Subtest-2	23.25	23.25	23.21
HSDPA Subtest-3	22.57	22.59	22.57
HSDPA Subtest-4	22.53	22.58	22.51
DC-HSDPA Subtest-1	23.09	23.06	23.18
DC-HSDPA Subtest-2	23.02	23.02	23.08
DC-HSDPA Subtest-3	22.94	22.95	22.88
DC-HSDPA Subtest-4	22.90	22.96	22.84
HSUPA Subtest-1	23.00	23.04	23.06
HSUPA Subtest-2	21.01	21.00	21.03
HSUPA Subtest-3	22.02	22.03	22.09
HSUPA Subtest-4	21.08	21.04	21.07
HSUPA Subtest-5	23.06	23.07	23.01

**ERP Power (dBm)**

Maximum Output Power		
Modulation	Cond. Power (dBm)	ERP (dBm)
RMC 12.2K	23.57	19.42
HSDPA	23.29	19.14
HSUPA	23.07	18.92

Note: EIRP (dBm) = Cond. Power (dBm) + Antenna Gain (dBi) + Array Gain (if applicable)

ERP (dBm) = EIRP (dBm) - 2.15



## 7.2 Modulation Characteristics

Input Power:	3.87 Vdc	Environmental Conditions:	22°C, 68% RH	Tested By:	Willy Cheng
--------------	----------	---------------------------	--------------	------------	-------------

### 7.2.1 GSM850

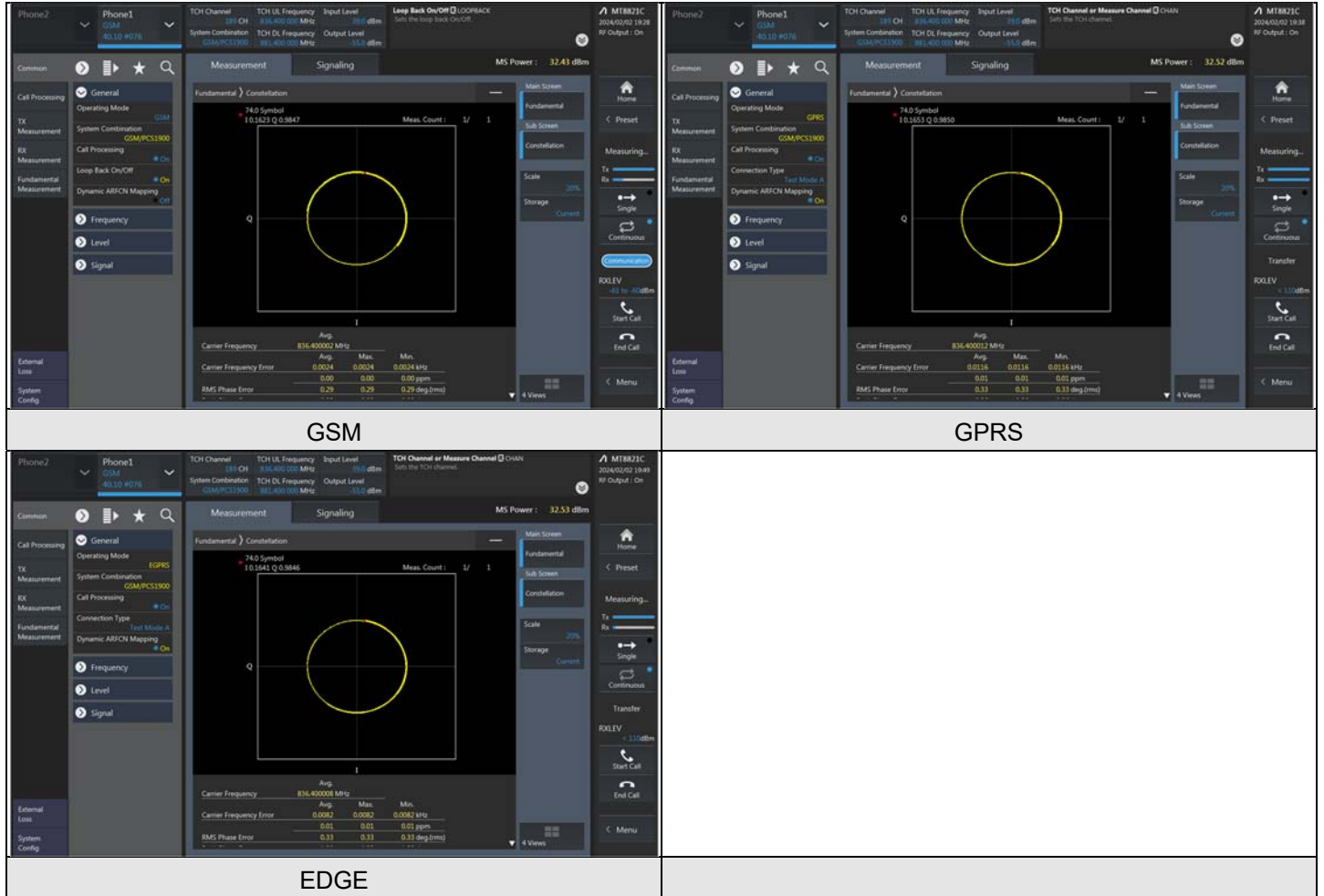

## 7.2.2 GSM1900

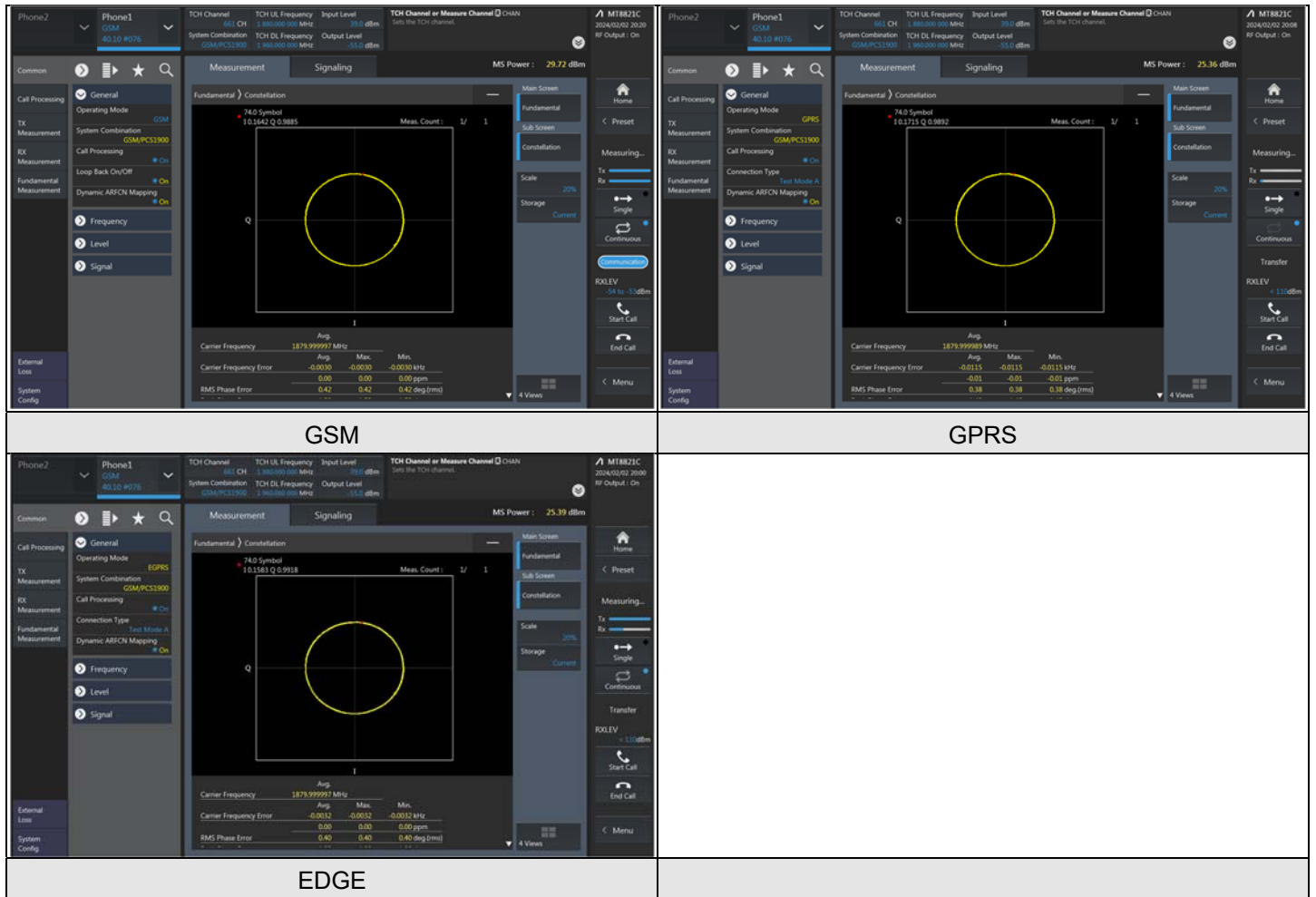

### 7.2.3 WCDMA Band 2

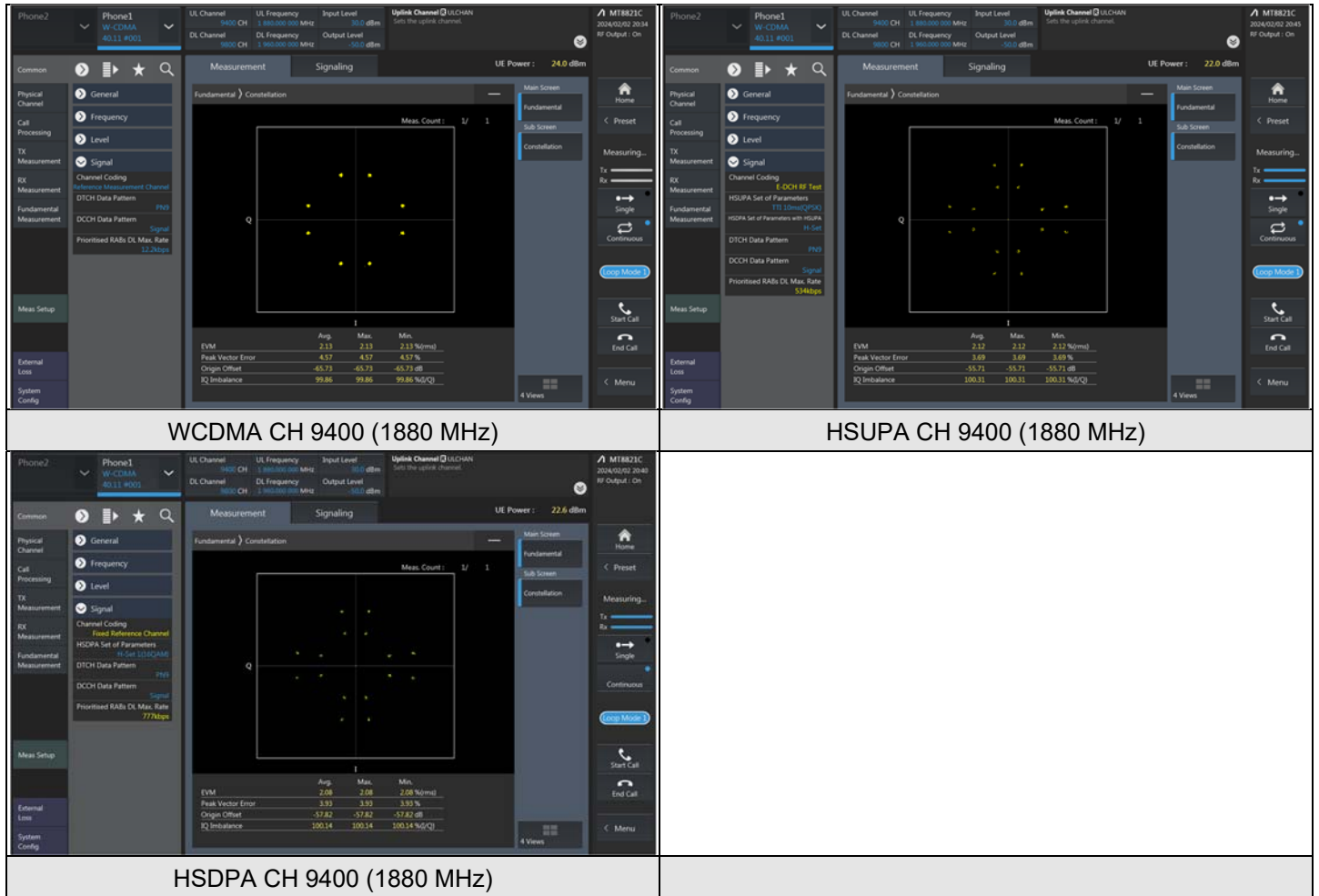

### 7.2.4 WCDMA Band 4

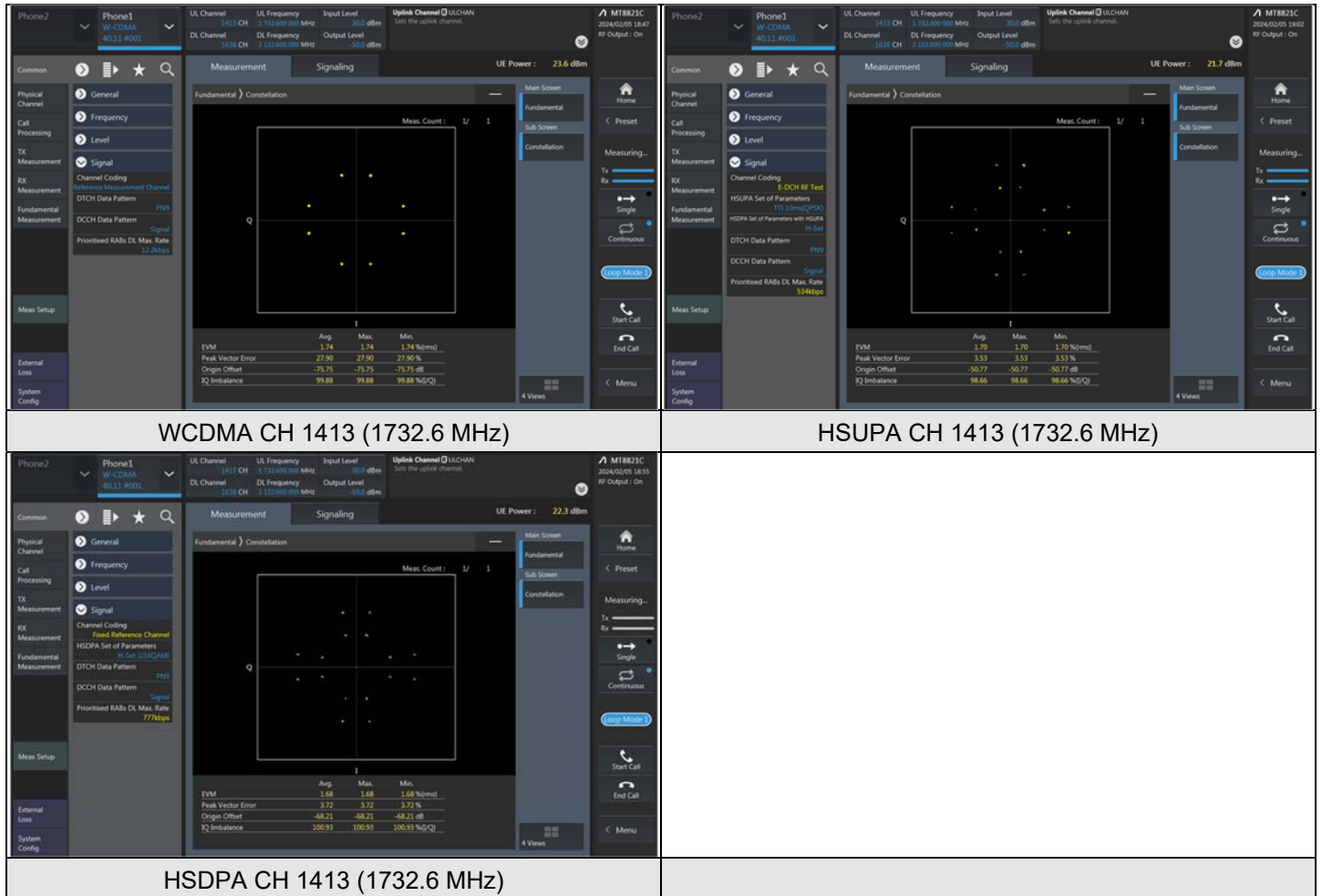

7.2.5 WCDMA Band 5

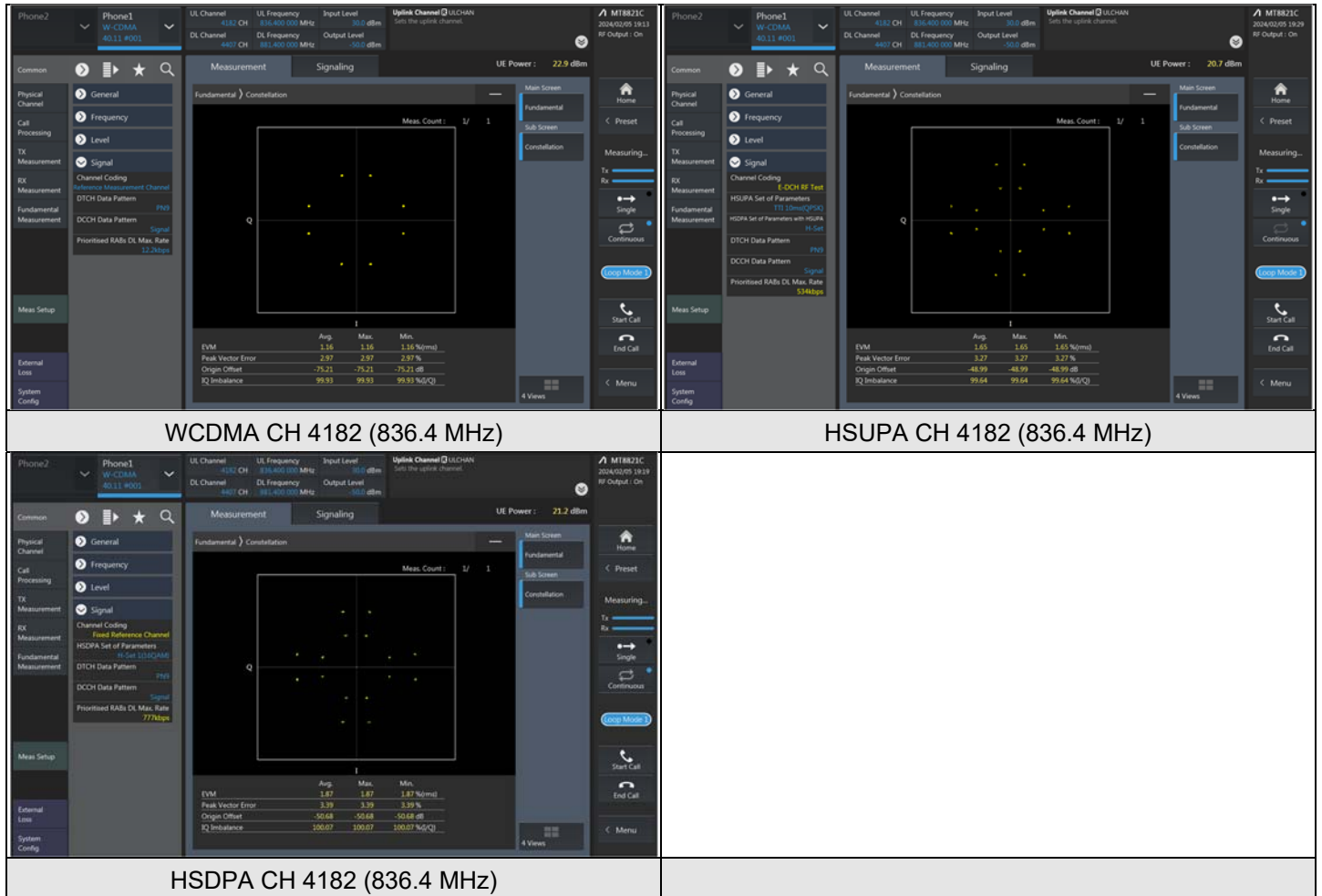

### 7.3 Peak to Average Ratio

Input Power:	3.87 Vdc	Environmental Conditions:	22°C, 68% RH	Tested By:	Willy Cheng
--------------	----------	---------------------------	--------------	------------	-------------

#### 7.3.1 GSM850

Modulation	Channel	Frequency (MHz)	Measurement Value(dB)	Limit (dB)	Result
GSM	128	824.2	2.77	13	Pass
GSM	189	836.4	2.80	13	Pass
GSM	251	848.8	2.80	13	Pass
GPRS	128	824.2	2.75	13	Pass
GPRS	189	836.4	2.79	13	Pass
GPRS	251	848.8	2.79	13	Pass
EDGE	128	824.2	2.74	13	Pass
EDGE	189	836.4	2.77	13	Pass
EDGE	251	848.8	2.77	13	Pass

Spectrum Plot of Worst Value



GSM CH 189 (836.4 MHz)

GPRS CH 189 (836.4 MHz)

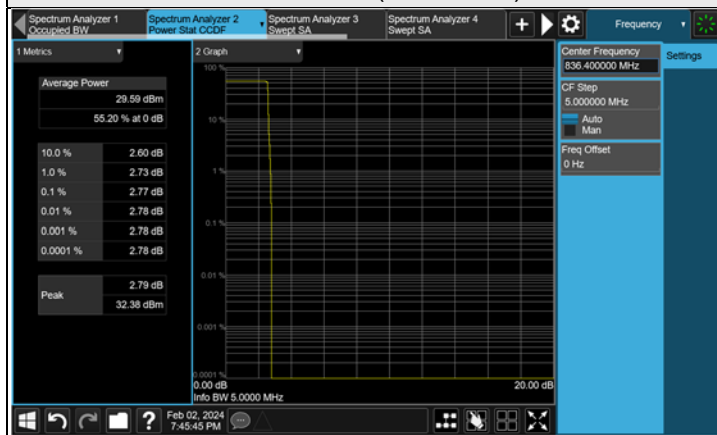

EDGE CH 189 (836.4 MHz)

7.3.2 GSM1900

Modulation	Channel	Frequency (MHz)	Measurement Value(dB)	Limit (dB)	Result
GSM	512	1850.2	2.66	13	Pass
GSM	661	1880.0	2.66	13	Pass
GSM	810	1909.8	2.66	13	Pass
GPRS	512	1850.2	2.67	13	Pass
GPRS	661	1880.0	2.66	13	Pass
GPRS	810	1909.8	2.66	13	Pass
EDGE	512	1850.2	2.66	13	Pass
EDGE	661	1880.0	2.67	13	Pass
EDGE	810	1909.8	2.66	13	Pass

Spectrum Plot of Worst Value



GSM CH 810 (1909.8 MHz)

EDGE CH 512 (1850.2 MHz)



EDGE CH 661 (1880.0 MHz)



7.3.3 WCDMA Band 2

Modulation	Channel	Frequency (MHz)	Measurement Value(dB)	Limit (dB)	Result
WCDMA	9262	1852.4	2.81	13	Pass
WCDMA	9400	1880	2.82	13	Pass
WCDMA	9538	1907.6	2.83	13	Pass
HSDPA	9262	1852.4	3.70	13	Pass
HSDPA	9400	1880	3.77	13	Pass
HSDPA	9538	1907.6	3.76	13	Pass
HSUPA	9262	1852.4	3.75	13	Pass
HSUPA	9400	1880	3.78	13	Pass
HSUPA	9538	1907.6	3.77	13	Pass

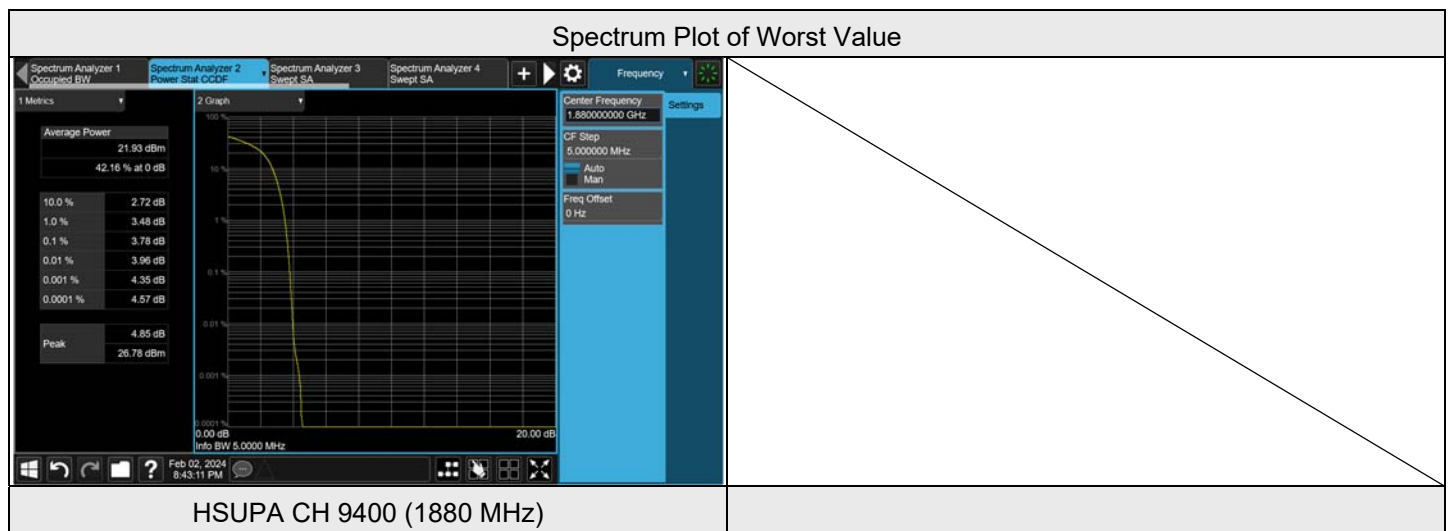



7.3.4 WCDMA Band 4

Modulation	Channel	Frequency (MHz)	Measurement Value(dB)	Limit (dB)	Result
WCDMA	1312	1712.4	2.93	13	Pass
WCDMA	1413	1732.6	3.01	13	Pass
WCDMA	1513	1752.6	2.96	13	Pass
HSDPA	1312	1712.4	3.82	13	Pass
HSDPA	1413	1732.6	3.85	13	Pass
HSDPA	1513	1752.6	3.83	13	Pass
HSUPA	1312	1712.4	3.84	13	Pass
HSUPA	1413	1732.6	3.88	13	Pass
HSUPA	1513	1752.6	3.85	13	Pass

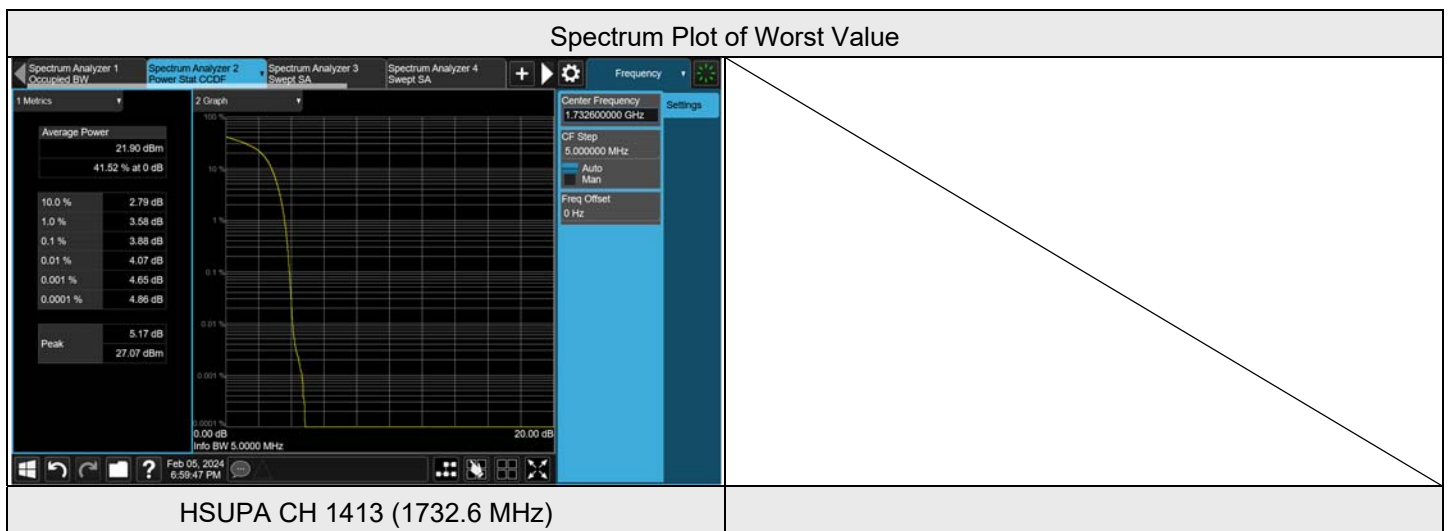

7.3.5 WCDMA Band 5

Modulation	Channel	Frequency (MHz)	Measurement Value(dB)	Limit (dB)	Result
WCDMA	4132	826.4	3.02	13	Pass
WCDMA	4182	836.4	2.92	13	Pass
WCDMA	4223	846.6	2.91	13	Pass
HSDPA	4132	826.4	3.98	13	Pass
HSDPA	4182	836.4	3.89	13	Pass
HSDPA	4223	846.6	4.01	13	Pass
HSUPA	4132	826.4	4.02	13	Pass
HSUPA	4182	836.4	3.95	13	Pass
HSUPA	4223	846.6	4.07	13	Pass

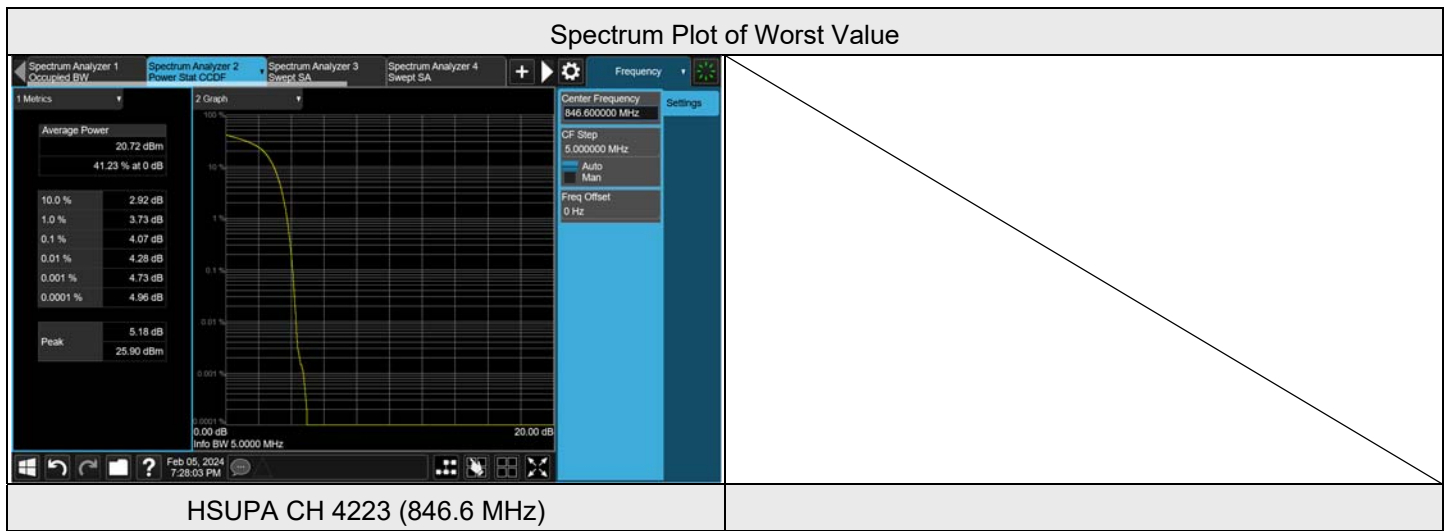

## 7.4 Bandwidth

Input Power:	3.87 Vdc	Environmental Conditions:	22°C, 68% RH	Tested By:	Willy Cheng
--------------	----------	---------------------------	--------------	------------	-------------

### 7.4.1 GSM850

Modulation	Channel	Frequency (MHz)	Occupied Bandwidth (kHz)	26 dB Bandwidth (kHz)
GSM	128	824.2	245.52	317.20
GSM	189	836.4	247.05	312.80
GSM	251	848.8	244.80	317.10
GPRS	128	824.2	243.93	315.70
GPRS	189	836.4	247.24	317.20
GPRS	251	848.8	246.58	316.30
EDGE	128	824.2	248.34	312.80
EDGE	189	836.4	245.98	316.60
EDGE	251	848.8	241.32	317.80

Spectrum Plot of Worst Value

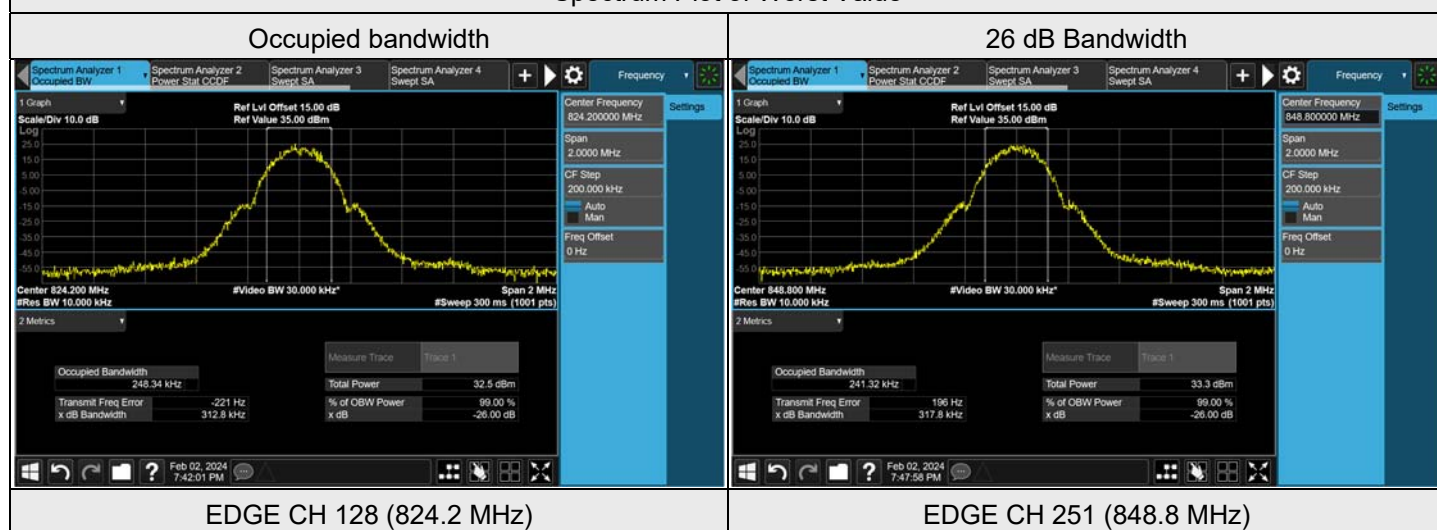

7.4.2 GSM1900

Modulation	Channel	Frequency (MHz)	Occupied Bandwidth (kHz)	26 dB Bandwidth (kHz)
GSM	512	1850.2	245.92	316.10
GSM	661	1880.0	247.97	315.10
GSM	810	1909.8	245.96	312.50
GPRS	512	1850.2	245.79	313.10
GPRS	661	1880.0	245.83	312.70
GPRS	810	1909.8	247.06	317.50
EDGE	512	1850.2	243.57	315.10
EDGE	661	1880.0	247.92	319.10
EDGE	810	1909.8	245.71	316.00

Spectrum Plot of Worst Value

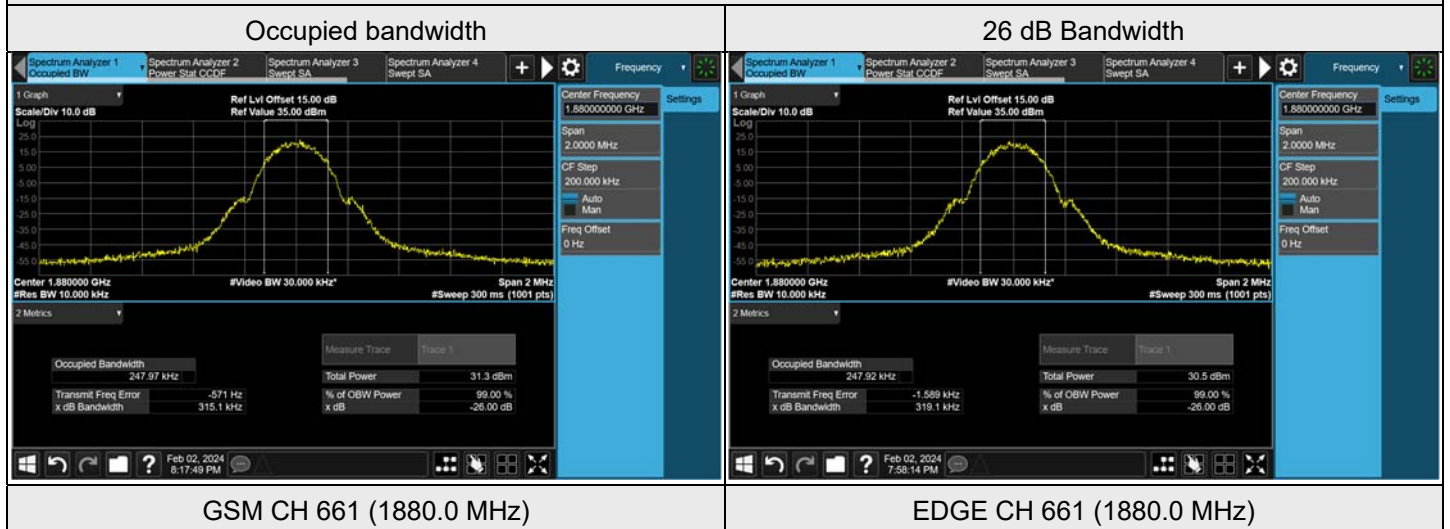

7.4.3 WCDMA Band 2

Modulation	Channel	Frequency (MHz)	Occupied Bandwidth (MHz)	26 dB Bandwidth (MHz)
WCDMA	9262	1852.4	4.167	4.729
WCDMA	9400	1880	4.173	4.738
WCDMA	9538	1907.6	4.168	4.728
HSDPA	9262	1852.4	4.161	4.727
HSDPA	9400	1880	4.171	4.708
HSDPA	9538	1907.6	4.168	4.708
HSUPA	9262	1852.4	4.161	4.706
HSUPA	9400	1880	4.166	4.700
HSUPA	9538	1907.6	4.160	4.710

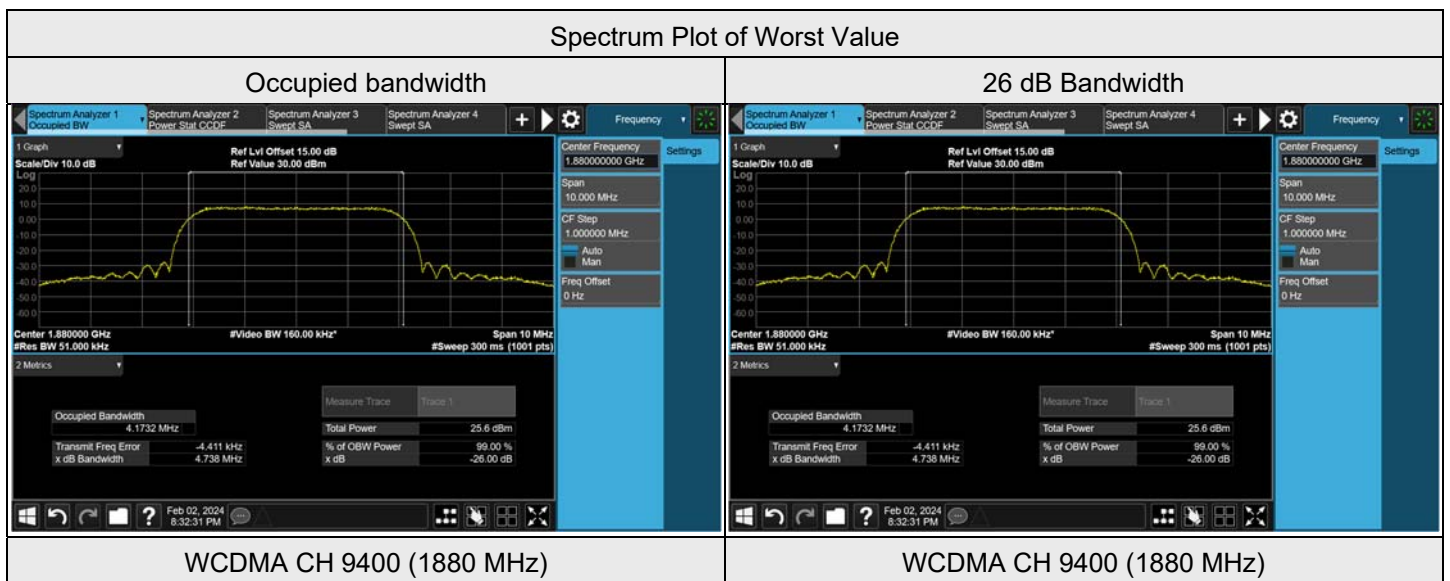

7.4.4 WCDMA Band 4

Modulation	Channel	Frequency (MHz)	Occupied Bandwidth (MHz)	26 dB Bandwidth (MHz)
WCDMA	1312	1712.4	4.169	4.716
WCDMA	1413	1732.6	4.156	4.701
WCDMA	1513	1752.6	4.160	4.714
HSDPA	1312	1712.4	4.166	4.711
HSDPA	1413	1732.6	4.163	4.690
HSDPA	1513	1752.6	4.164	4.701
HSUPA	1312	1712.4	4.168	4.703
HSUPA	1413	1732.6	4.164	4.703
HSUPA	1513	1752.6	4.162	4.713

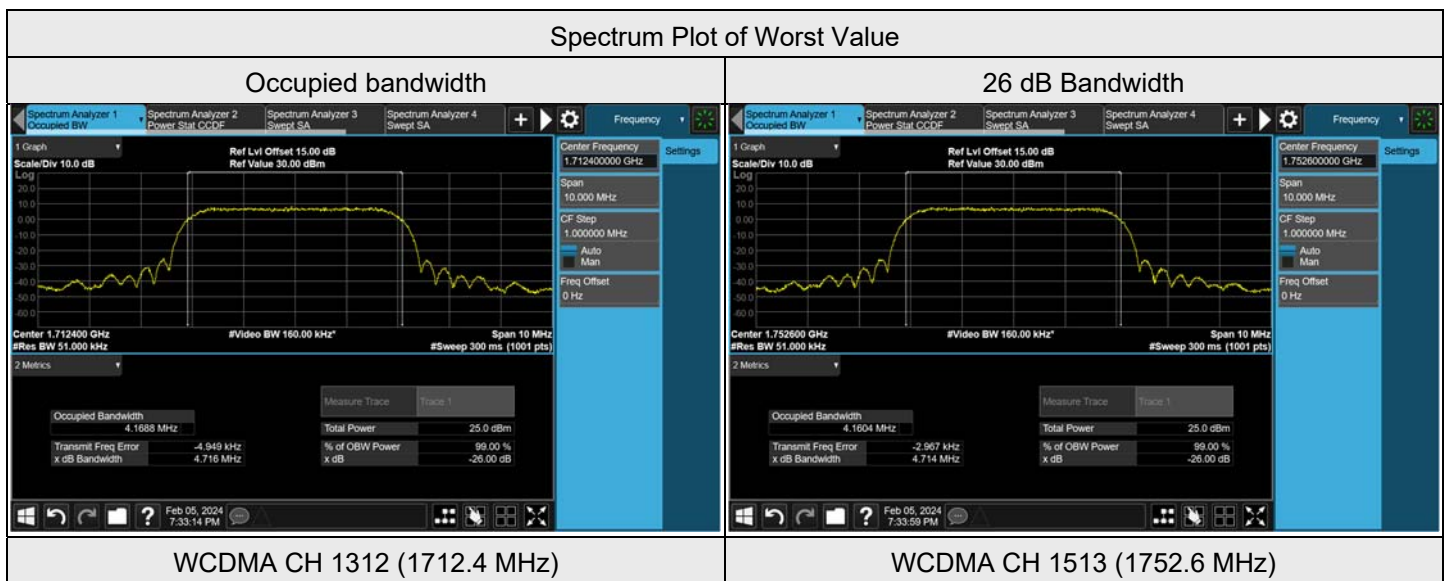

7.4.5 WCDMA Band 5

Modulation	Channel	Frequency (MHz)	Occupied Bandwidth (MHz)	26 dB Bandwidth (MHz)
WCDMA	4132	826.4	4.149	4.698
WCDMA	4182	836.4	4.148	4.693
WCDMA	4223	846.6	4.151	4.703
HSDPA	4132	826.4	4.155	4.687
HSDPA	4182	836.4	4.153	4.696
HSDPA	4223	846.6	4.154	4.700
HSUPA	4132	826.4	4.149	4.699
HSUPA	4182	836.4	4.151	4.707
HSUPA	4223	846.6	4.160	4.679

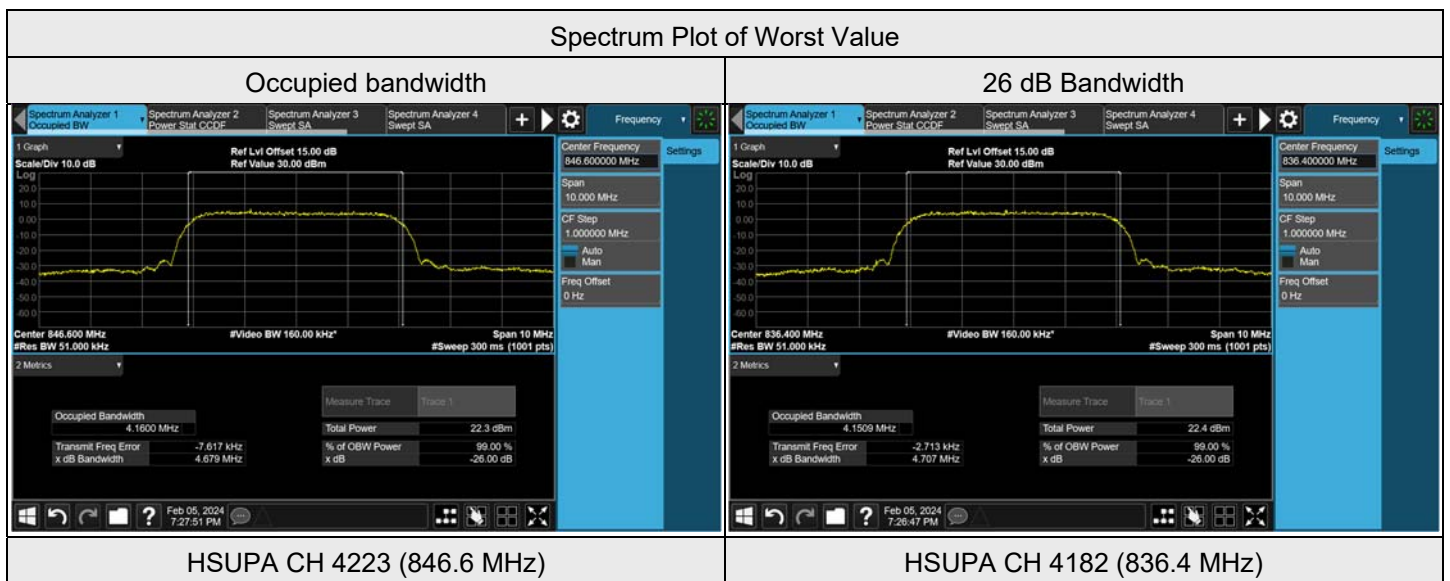



## 7.5 Conducted Spurious Emissions

Input Power:	3.87 Vdc	Environmental Conditions:	22°C, 68% RH	Tested By:	Willy Cheng
--------------	----------	---------------------------	--------------	------------	-------------

### 7.5.1 GSM





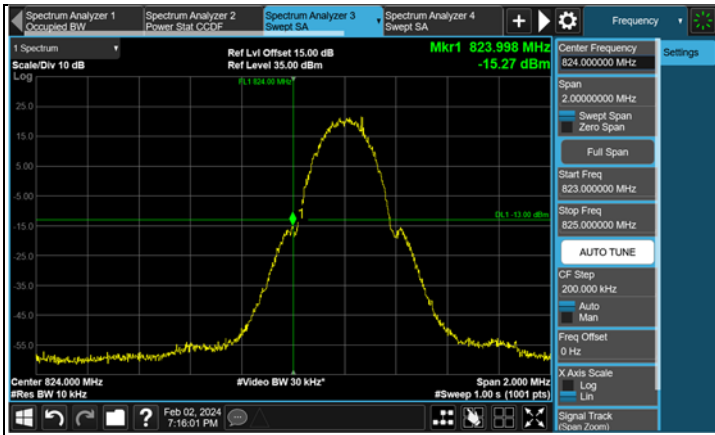

CH 128 (824.2 MHz)

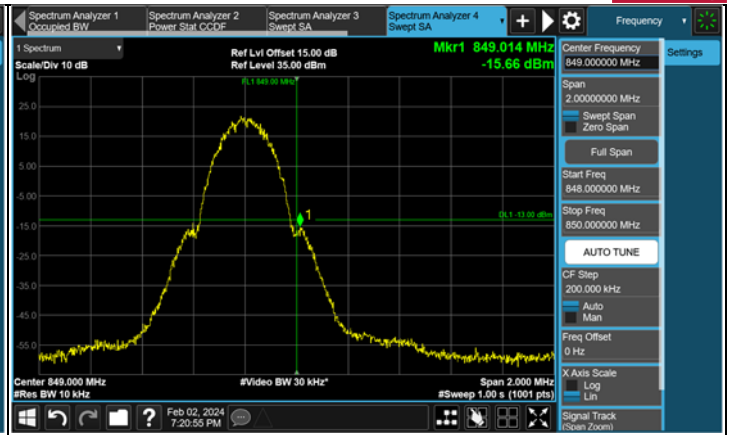

CH 251 (848.8 MHz)

### GPRS

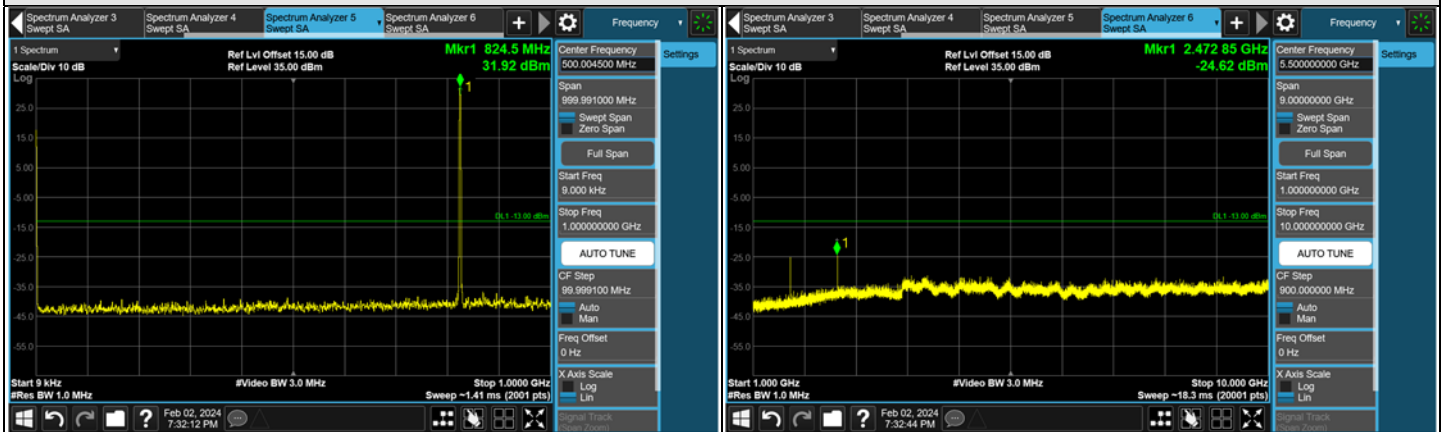

### CH 128 (824.2 MHz)



### CH 189 (836.4 MHz)



### CH 251 (848.8 MHz)

Note: The signal at 9 kHz is IF signal from spectrum analyzer.

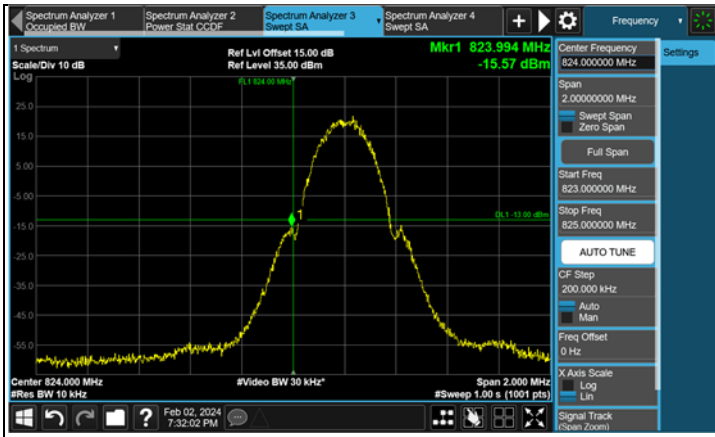

CH 128 (824.2 MHz)

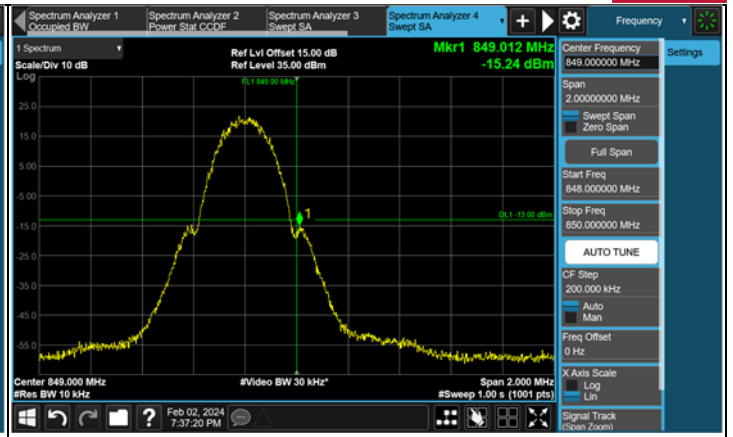

CH 251 (848.8 MHz)

### EDGE

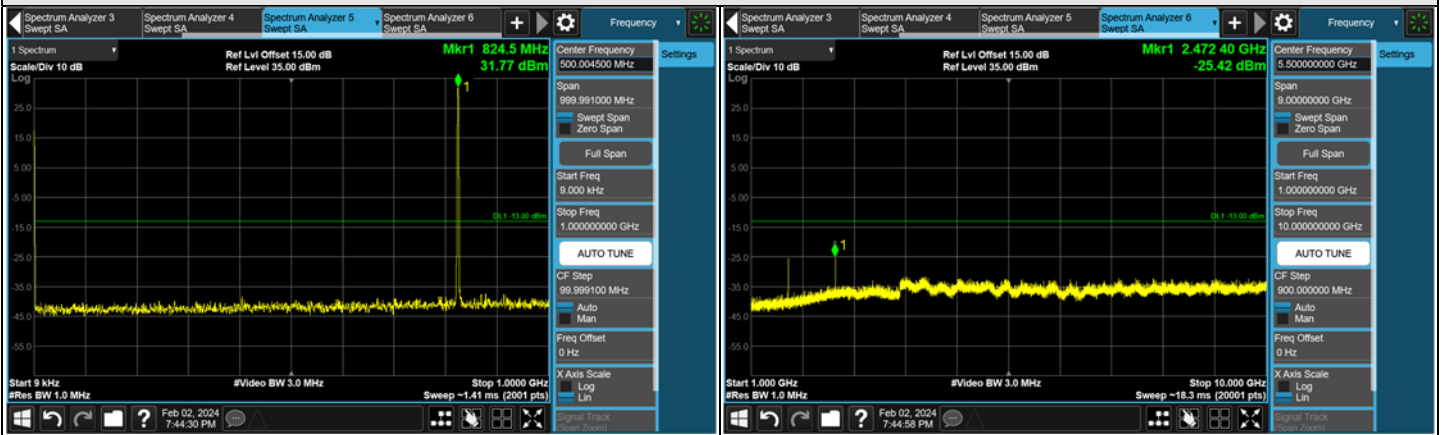

### CH 128 (824.2 MHz)



### CH 189 (836.4 MHz)

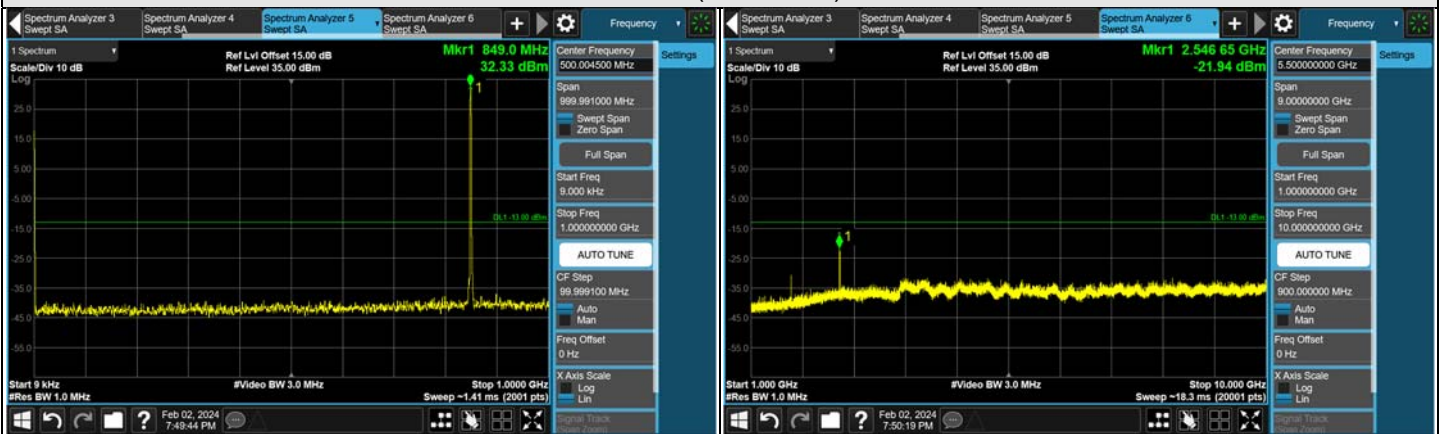

### CH 251 (848.8 MHz)

Note: The signal at 9 kHz is IF signal from spectrum analyzer.

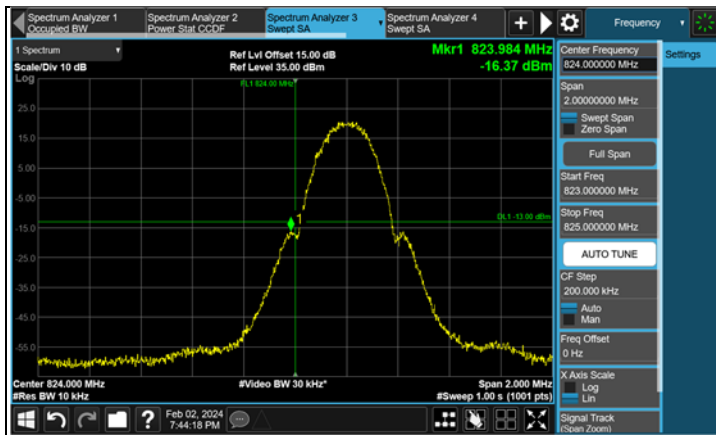

CH 128 (824.2 MHz)

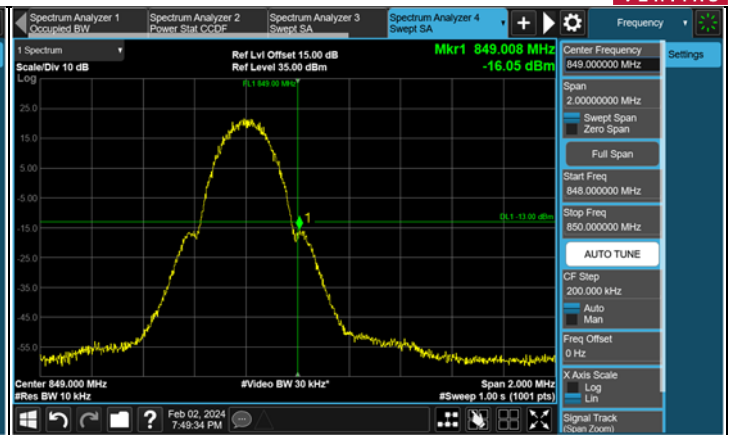

CH 251 (848.8 MHz)



### 7.5.2 GSM1900

### GSM



### CH 512 (1850.2 MHz)



### CH 661 (1880 MHz)



### CH 810 (1909.8 MHz)

Note: The signal at 9 kHz is IF signal from spectrum analyzer.

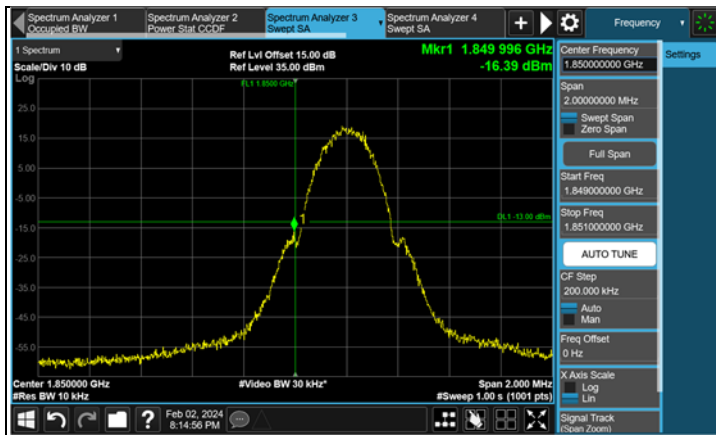

CH 512 (1850.2 MHz)

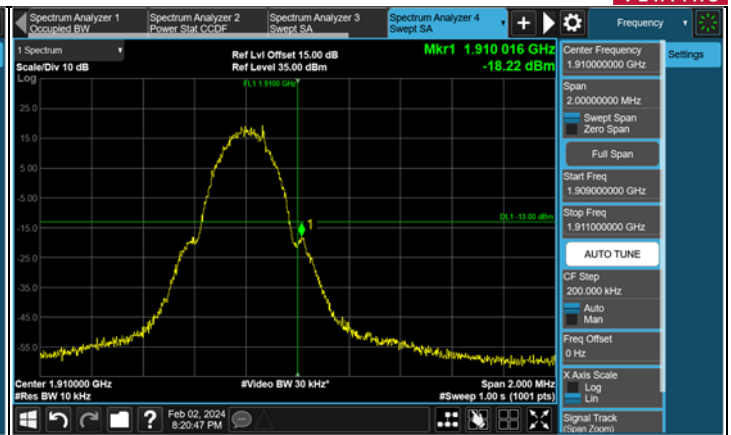

CH 810 (1909.8 MHz)

### GPRS

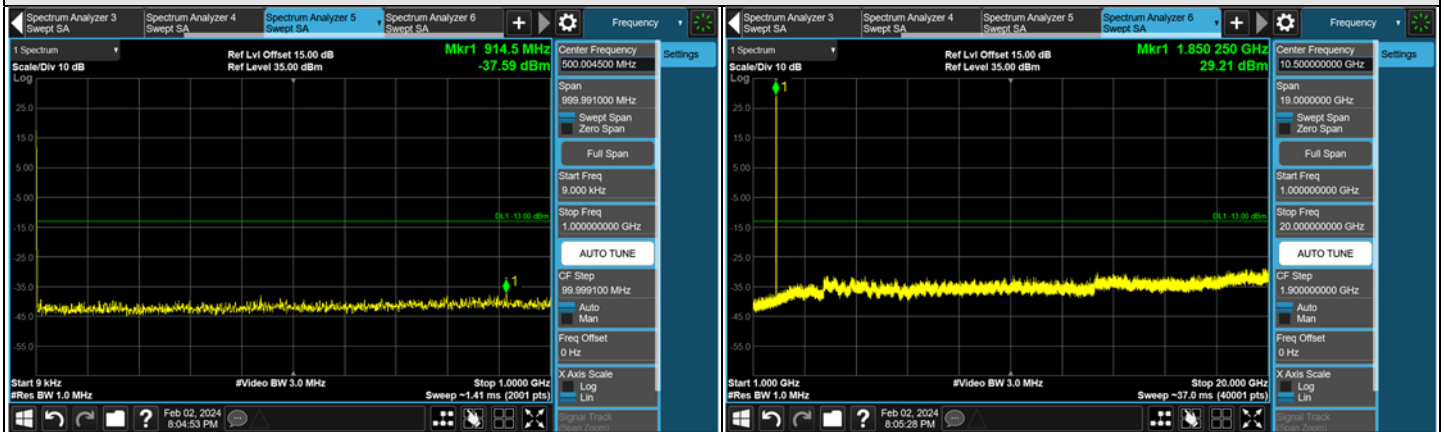

### CH 512 (1850.2 MHz)



### CH 661 (1880 MHz)

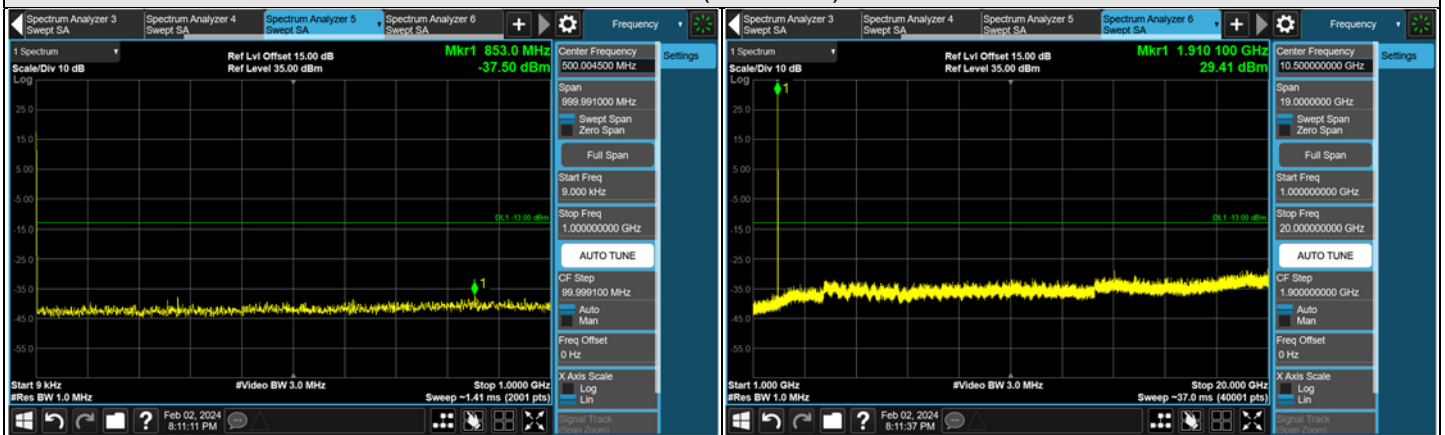

### CH 810 (1909.8 MHz)

Note: The signal at 9 kHz is IF signal from spectrum analyzer.



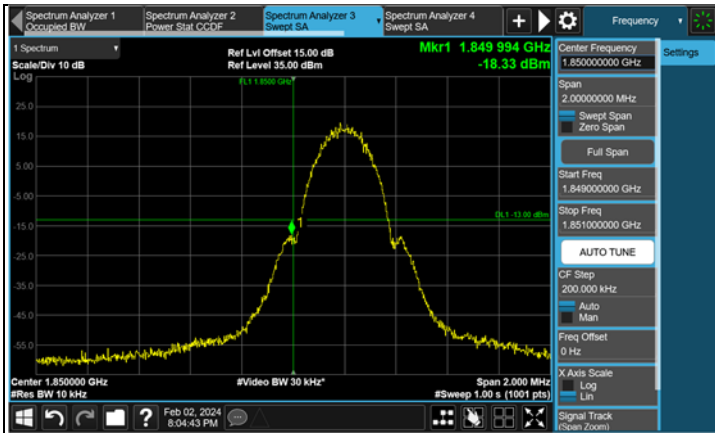

CH 512 (1850.2 MHz)

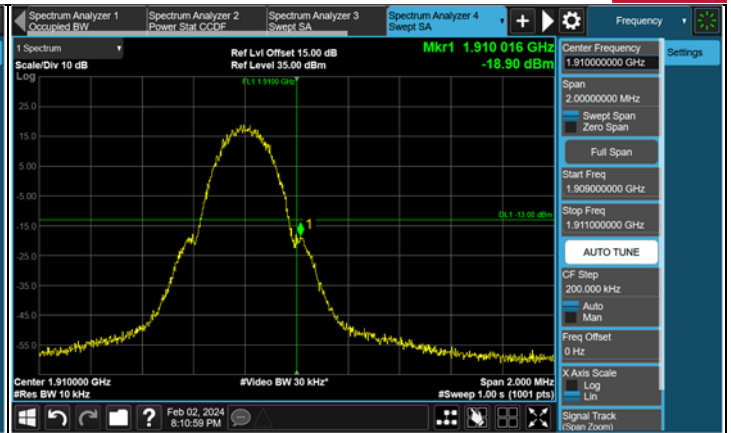

CH 810 (1909.8 MHz)

### EDGE



### CH 512 (1850.2 MHz)

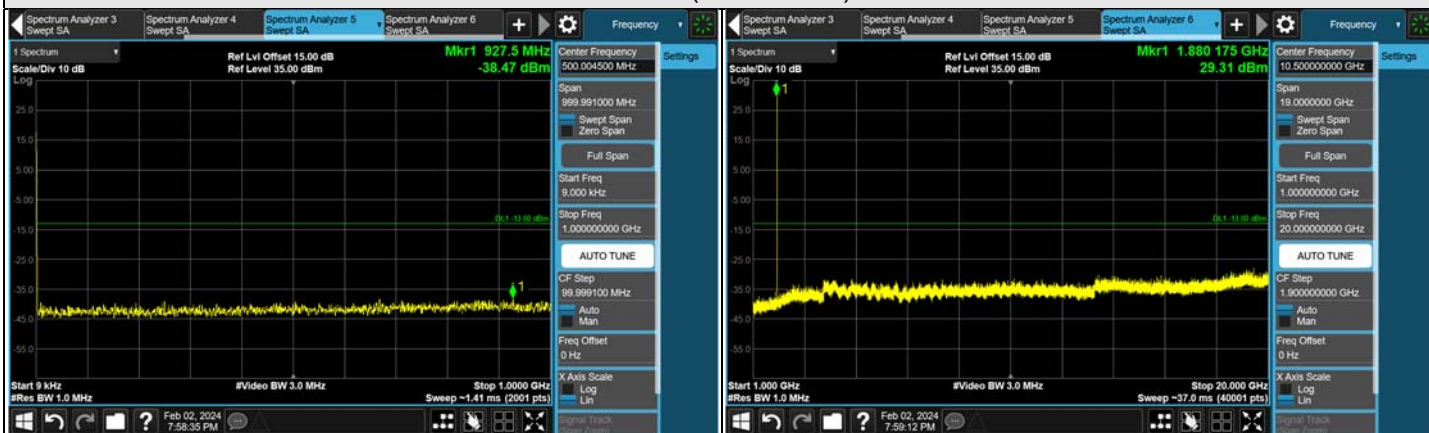

### CH 661 (1880 MHz)

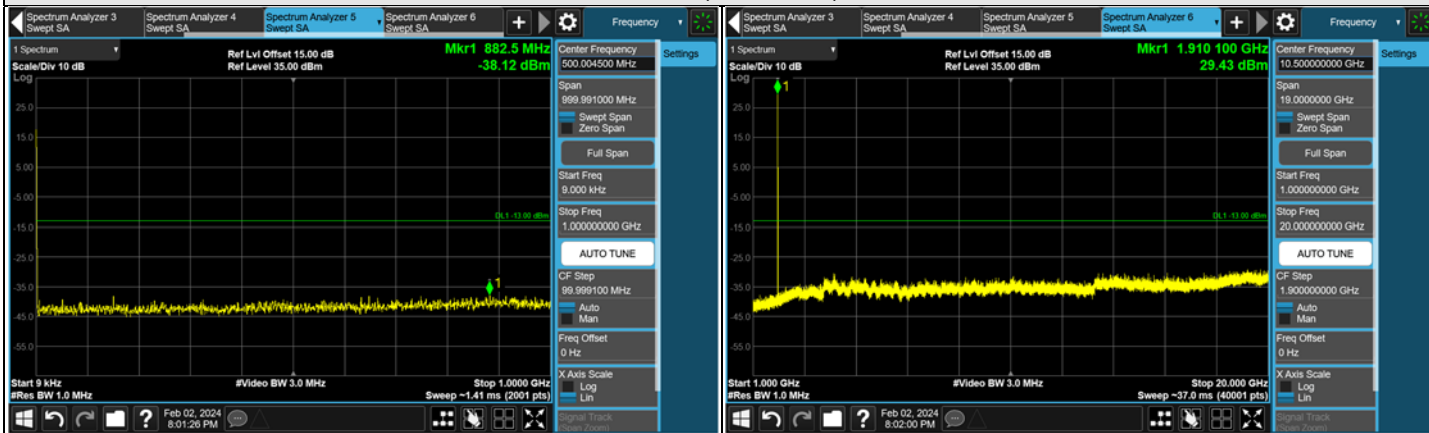

### CH 810 (1909.8 MHz)

Note: The signal at 9 kHz is IF signal from spectrum analyzer.

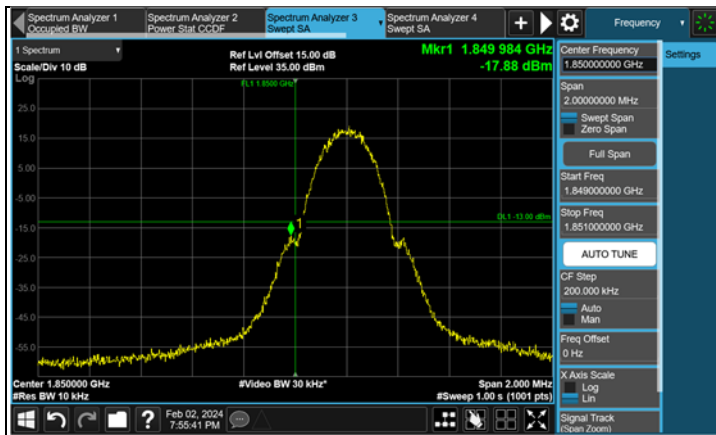

CH 512 (1850.2 MHz)

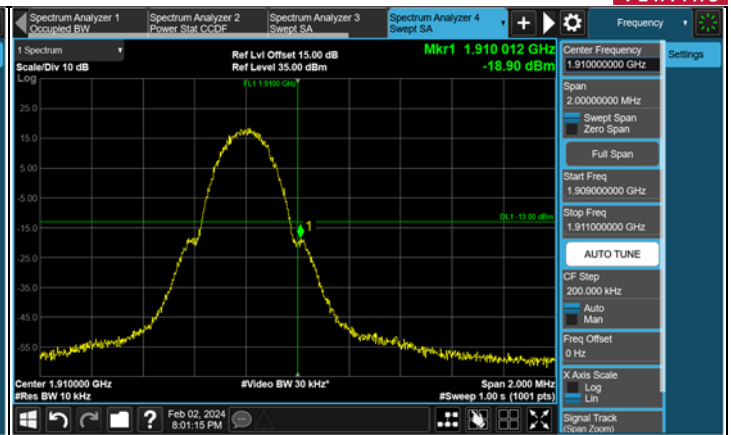

CH 810 (1909.8 MHz)

### 7.5.3 WCDMA Band 2

#### WCDMA

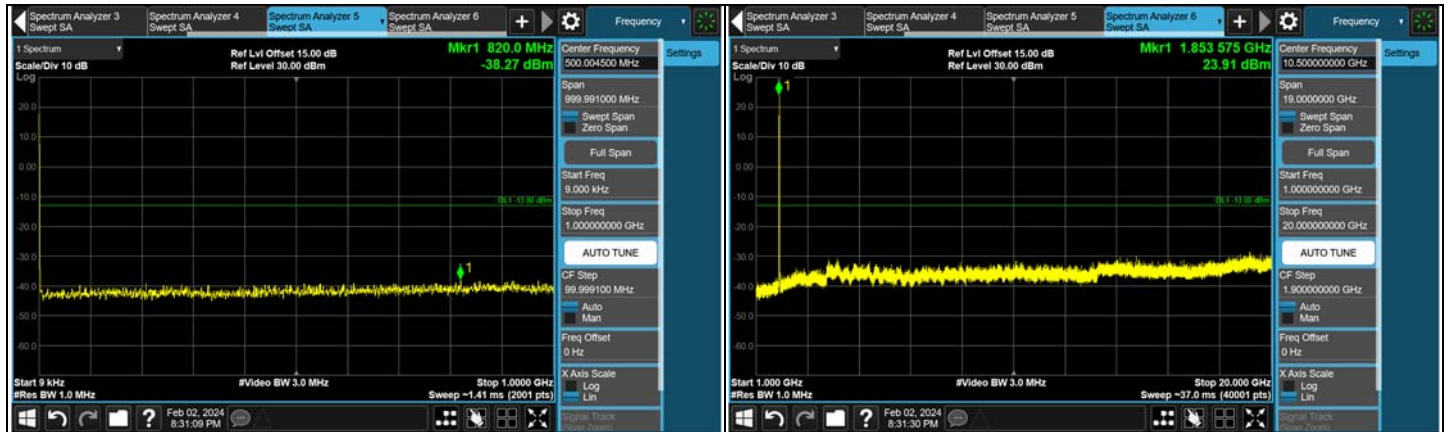

CH 9262 (1852.4 MHz)

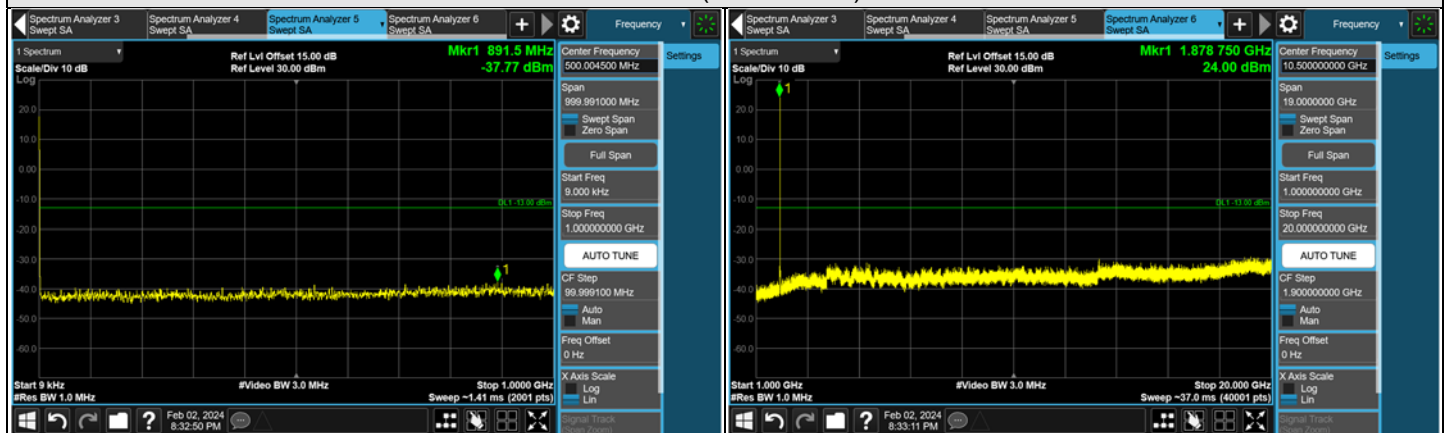

CH 9400 (1880 MHz)

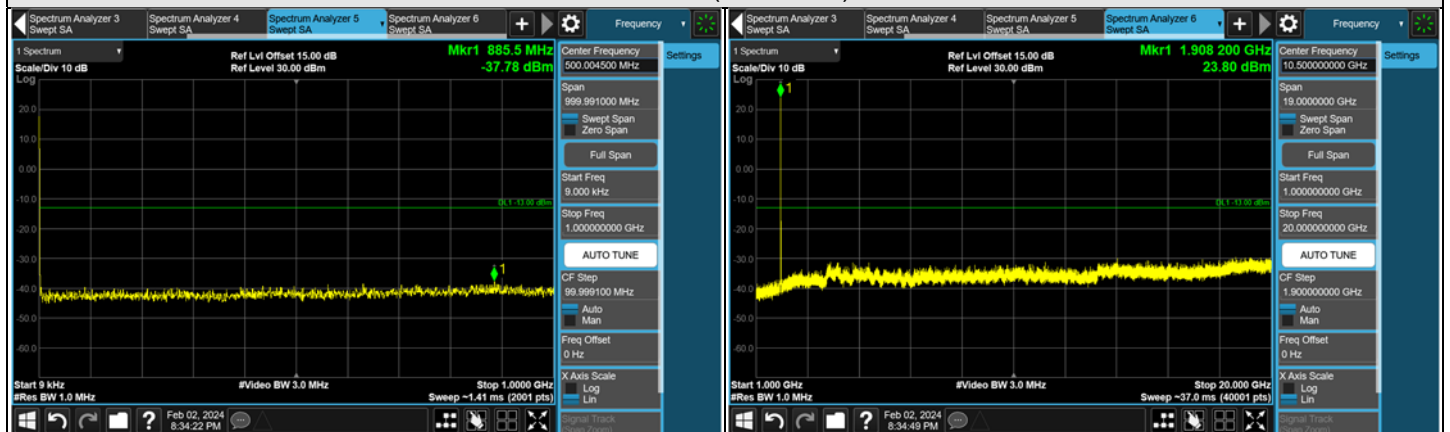

CH 9538 (1907.6 MHz)

Note: The signal at 9 kHz is IF signal from spectrum analyzer.



CH 9262 (1852.4 MHz)



CH 9538 (1907.6 MHz)