

FCC SAR Test Report

Product Name : Mobile Computer

Model No. : RS36

Applicant : CipherLab Co., Ltd.

Address : 12F, 333, Dunhua S.Rd., Sec.2, Taipei, Taiwan

Date of Receipt : 2022/10/13

Issued Date : 2023/04/12

Report No. : 22A0299R-SAUSV01S-A

Report Version : V1.0



The test results relate only to the samples tested.

The test results shown in the test report are traceable to the national/international standard through the calibration report of the equipment and evaluated measurement uncertainty herein.

This report must not be used to claim product endorsement by TAF or any agency of the government.

The test report shall not be reproduced without the written approval of DEKRA Testing and Certification Co., Ltd.

Measurement uncertainties evaluated for each testing system and associated connections are given here to provide the system information for reference. Compliance determinations do not take into account measurement uncertainties for each testing system, but are based on the results of the compliance measurement.

Test Report

Issued Date: 2023/04/12
 Report No.: 22A0299R-SAUSV01S-A



Product Name : Mobile Computer
 Applicant : CipherLab Co., Ltd.
 Address : 12F, 333, Dunhua S.Rd., Sec.2, Taipei, Taiwan
 Manufacturer : Cipherlab Co., Ltd.
 Model No. : RS36
 Trade Name : CIPHERLAB
 FCC ID : Q3N-RS36
 Applicable Standard : IEEE 1528-2013
 KDB 447498 D01 v06
 KDB 865664 D01 v01r04
 Measurement : 47CFR § 2.1093
 Procedures : KDB 248227 D01 v02r02
 KDB 648474 D04 v01r03
 KDB 941225 D01 v03r01
 KDB 941225 D05 v02r05
 KDB 941225 D06 v02r01
 Test Result : Max. SAR Measurement (1g)
 WLAN: **1.087** W/kg
 WWAN: **1.199** W/kg
 Application Type : Certification

The above equipment has been tested by DEKRA, and found compliance with the requirement of the above standards. The test record, data evaluation & Equipment Under Test (EUT) configurations represented herein are true and accurate accounts of the measurements of the sample's SAR characteristics under the conditions specified in this report.

Documented By : April Chen
 (Senior Project Specialist / April Chen)

Tested By : Luke Cheng
 (Senior Engineer / Luke Cheng)

Approved By : San Lin
 (Assistant Manager / San Lin)

TABLE OF CONTENTS

Description	Page
1. General Information	5
1.1 EUT Description	5
1.2 Antenna List	5
1.3 SAR Test Exclusion Calculation	6
1.4 Test Environment	7
2. SAR Measurement System	8
2.1 DASY5 System Description	8
2.1.1 Applications	9
2.1.2 Area Scans	9
2.1.3 Zoom Scan (Cube Scan Averaging)	9
2.1.4 Uncertainty of Inter-/Extrapolation and Averaging	9
2.2 DASY5 E-Field Probe	10
2.2.1 Isotropic E-Field Probe Specification	10
2.3 Boundary Detection Unit and Probe Mounting Device	11
2.4 DATA Acquisition Electronics (DAE) and Measurement Server	11
2.5 Robot	12
2.6 Light Beam Unit	12
2.7 Device Holder	13
2.8 SAM Twin Phantom	13
3. Tissue Simulating Liquid	14
3.1 The composition of the tissue simulating liquid	14
3.2 Tissue Calibration Result	14
3.3 Tissue Dielectric Parameters for Head and Body Phantoms	18
4. SAR Measurement Procedure	19
4.1 SAR System Check	19
4.1.1 Dipoles	19
4.1.2 System Check Result	20
4.2 SAR Measurement Procedure	23
5. SAR Exposure Limits	24
6. Test Equipment List	25
8. Conducted Power Measurement (Including tolerance allowed for production unit)	30
9. Test Results	59
9.1 SAR Test Results Summary	59
9.2 Simultaneous Transmission	77
9.2.1 Simultaneous transmission of Wi-Fi and other wireless technologies	79
10. SAR measurement variability	81
Appendix	
Appendix A. SAR System Check Data	
Appendix B. SAR measurement Data	
Appendix C. Test Setup Photographs	
Appendix D. Probe Calibration Data	
Appendix E. Dipole Calibration Data	
Appendix F. Product Photos-Please refer to the file: 22A0299R-Product Photos	

Revision History

Report No.	Version	Description	Issued Date
22A0299R-SAUSV01S-A	V1.0	Initial issue of report.	2023/04/12

1. General Information

1.1 EUT Description

Product Name	Mobile Computer			
Trade Name	CIPHERLAB			
Model No.	RS36			
FCC ID	Q3N-RS36			
Frequency Range (Licensed)	GSM850/WCDMA B5/ LTE Band 5: 824-849MHz PCS1900/WCDMA B2/ LTE Band 2: 1850-1910MHz WCDMA B4/LTE Band 4: 1710-1755MHz LTE Band 7: 2500-2570MHz, LTE Band 12: 699-716MHz LTE Band 13: 777-787MHz, LTE Band 17: 704-716MHz LTE Band 25: 1850-1915MHz, LTE Band 26: 814-849MHz LTE Band 38: 2570-2620MHz, LTE Band 41: 2545-2655MHz LTE Band 66: 1710-1780MHz			
Frequency Range	WLAN 2.4GHz: 2412-2462MHz WLAN 5GHz: 5180-5240MHz, 5260-5320, 5500-5720MHz, 5745-5825MHz BT: 2402-2480MHz			
Type of Modulation	802.11b: DSSS 802.11a/g/n/ac: OFDM GFSK(1Mbps) / π /4DQPSK(2Mbps) / 8DPSK(3Mbps) WCDMA: RMC/AMR 12.2Kbps/HSDPA/HSUPA LTE: QPSK/16QAM/64QAM			
Device Category	Portable			
RF Exposure Environment	Uncontrolled			
Summary of test result – Reported Head/Body 1g SAR (W/kg)				
Test configuration	Licensed	DTS	NII	DSS(BT)
Head	0.900	0.833	1.087	0.052
Body	1.199	0.211	0.338	0.015
Simultaneous	1.858 (SPLSR=0.033)			
Summary of test result – Reported Product Specific 10g SAR (W/kg)				
Test configuration	Licensed	DTS	NII	DSS(BT)
Product Specific	N/A	0.535	0.682	0.057
Simultaneous	0.702			

1.2 Antenna List

No.	Manufacturer	Part No.	Antenna Type
1	Auden	KZWLSLSVS0001 (WWAN Main)	PIFA
2	Auden	KZWLSLSVS0001 (WWAN Aux)	PIFA
3	Auden	BRS36ANT00001 (WLAN/BT)	PIFA

Note: The above EUT information by manufacturer.

1.3 SAR Test Exclusion Calculation

Referring to KDB 941225 D06, when the distance from the antenna to the edge is > 25mm, SAR is not required.

Antenna	Distance from the antenna to the edge					
	Front	Back	Left-side	Right-side	Top	Bottom
WWAN Main	< 25mm	< 25mm	< 25mm	< 25mm	> 25mm	< 25mm
	Yes	Yes	Yes	Yes	No	Yes
WLAN/BT	< 25mm	< 25mm	> 25mm	> 25mm	< 25mm	> 25mm
	Yes	Yes	No	Yes	Yes	No

1.4 Test Environment

Ambient conditions in the laboratory:

Test Date: 2022/12/10–2022/12/27

Items	Required	Actual
Temperature (°C)	18-25	23 ±2
Humidity (%RH)	30-70	50 ±20

USA : FCC Registration Number: TW0033
Canada : CAB Identifier Number: TW3023 / Company Number: 26930

Site Description : Accredited by TAF
Accredited Number: 3023

Test Laboratory : DEKRA Testing and Certification Co., Ltd
Address : No. 26, Huaya 1st Rd., Guishan Dist.,
Taoyuan City 333411, Taiwan, R.O.C.

Phone Number : 886-3-275-7255
Fax Number : 886-3-327-8031
Email Address : info.tw@dekra.com
Website : <http://www.dekra.com.tw>

2. SAR Measurement System

2.1 DASY5 System Description

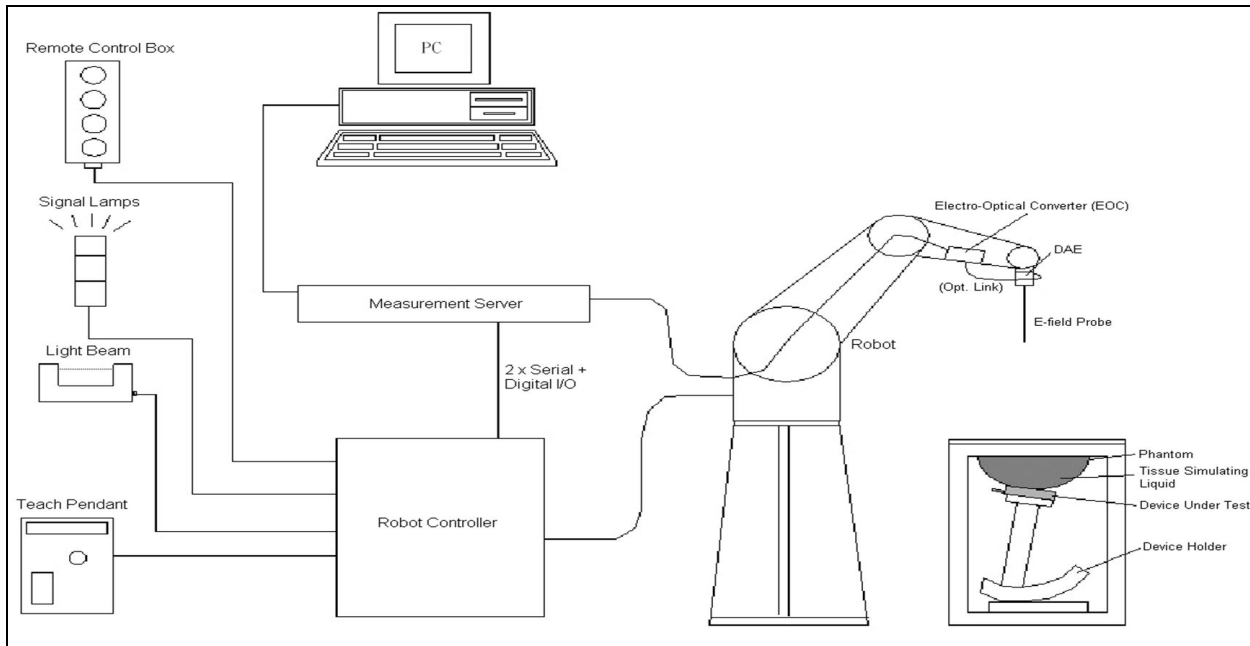

The DASY5 system for performing compliance tests consists of the following items:

- A standard high precision 6-axis robot with controller, teach pendant and software. An arm extension for accommodating the data acquisition electronics (DAE).
- A data acquisition electronics (DAE) which performs the signal amplification, signal multiplexing, AD-conversion, offset measurements, mechanical surface detection, collision detection, etc. The unit is battery powered with standard or rechargeable batteries. The signal is optically transmitted to the EOC.
- The Electro-optical converter (EOC) performs the conversion from optical to electrical signals for the digital communication to the DAE. To use optical surface detection, a special version of the EOC is required. The EOC signal is transmitted to the measurement server.
- The Light Beam used is for probe alignment. This improves the (absolute) accuracy of the probe positioning.
- A computer running WinXP and the DASY5 software.
- Remote control and teach pendant as well as additional circuitry for robot safety such as warning lamps, etc.
- The phantom, the device holder and other accessories according to the targeted measurement.

2.1.1 Applications

Predefined procedures and evaluations for automated compliance testing with all worldwide standards, e.g., IEEE 1528, OET 65, IEC 62209-1, IEC 62209-2, EN 50360, EN 50383 and others.

2.1.2 Area Scans

Area scans are defined prior to the measurement process being executed with a user defined variable spacing between each measurement point (integral) allowing low uncertainty measurements to be conducted. Scans defined for FCC applications utilize a 10mm² step integral, with 1mm interpolation used to locate the peak SAR area used for zoom scan assessments.

When an Area Scan has measured all reachable points, it computes the field maxima found in the scanned area, within a range of the global maximum. The range (in dB) is specified in the standards for compliance testing. For example, a 2 dB range is required in IEEE 1528-2013, EN 50361 and IEC 62209 standards, whereby 3 dB is a requirement when compliance is assessed in accordance with the ARIB standard (Japan).

2.1.3 Zoom Scan (Cube Scan Averaging)

Zoom Scans are used to assess the peak spatial SAR values within a cubic averaging volume containing 1 g and 10 g of simulated tissue. A density of 1000 kg/m³ is used to represent the head and body tissue density and not the phantom liquid density, in order to be consistent with the definition of the liquid dielectric properties, i.e. the side length of the 1 g cube is 10mm, with the side length of the 10 g cube 21,5mm.

The zoom scan integer steps can be user defined so as to reduce uncertainty, but normal practice for typical test applications (including FCC) utilize a physical step of 5x5x7 (8mmx8mmx5mm) providing a volume of 32mm in the X & Y axis, and 30mm in the Z axis.

2.1.4 Uncertainty of Inter-/Extrapolation and Averaging

In order to evaluate the uncertainty of the interpolation, extrapolation and averaged SAR calculation algorithms of the Postprocessor, DASY5 allows the generation of measurement grids which are artificially predefined by analytically based test functions. Therefore, the grids of area scans and zoom scans can be filled with uncertainty test data, according to the SAR benchmark functions of IEEE 1528. The three analytical functions shown in equations as below are used to describe the possible range of the expected SAR distributions for the tested

handsets. The field gradients are covered by the spatially flat distribution f1, the spatially steep distribution f3 and f2 accounts for H-field cancellation on the phantom/tissue surface.

$$f_1(x, y, z) = Ae^{-\frac{z}{2a}} \cos^2 \left(\frac{\pi \sqrt{x'^2 + y'^2}}{2 \cdot 5a} \right)$$

$$f_2(x, y, z) = Ae^{-\frac{z}{a}} \frac{a^2}{a^2 + x'^2} \left(3 - e^{-\frac{2z}{a}} \right) \cos^2 \left(\frac{\pi y'}{2 \cdot 3a} \right)$$

$$f_3(x, y, z) = A \frac{a^2}{\frac{a^2}{4} + x'^2 + y'^2} \left(e^{-\frac{2z}{a}} + \frac{a^2}{2(a + 2z)^2} \right)$$

2.2 DASY5 E-Field Probe

The SAR measurement is conducted with the dosimetric probe manufactured by SPEAG. The probe is specially designed and calibrated for use in liquid with high permittivity. The dosimetric probe has special calibration in liquid at different frequency.

SPEAG conducts the probe calibration in compliance with international and national standards (e.g. IEEE 1528, EN 62209-1, IEC 62209, etc.) under ISO 17025. The calibration data are in Appendix D.

2.2.1 Isotropic E-Field Probe Specification

Model	Ex3DV4	
Construction	Symmetrical design with triangular core Built-in shielding against static charges PEEK enclosure material (resistant to organic solvents, e.g., DGBE)	
Frequency	10 MHz to 6 GHz Linearity: ± 0.2 dB (30 MHz to 6 GHz)	
Directivity	± 0.3 dB in HSL (rotation around probe axis) ± 0.5 dB in tissue material (rotation normal to probe axis)	
Dynamic Range	10 µW/g to 100 mW/g Linearity: ± 0.2 dB (noise: typically < 1 µW/g)	
Dimensions	Overall length: 330 mm (Tip: 20 mm) Tip diameter: 2.5 mm (Body: 12 mm) Typical distance from probe tip to dipole centers: 1 mm	
Application	High precision dosimetric measurements in any exposure scenario (e.g., very strong gradient fields). Only probe which enables compliance testing for frequencies up to 6 GHz with precision of better 30%.	

2.3 Boundary Detection Unit and Probe Mounting Device

The DASY probes use a precise connector and an additional holder for the probe, consisting of a plastic tube and a flexible silicon ring to center the probe. The connector at the DAE is flexibly mounted and held in the default position with magnets and springs. Two switching systems in the connector mount detect frontal and lateral probe collisions and trigger the necessary software response.

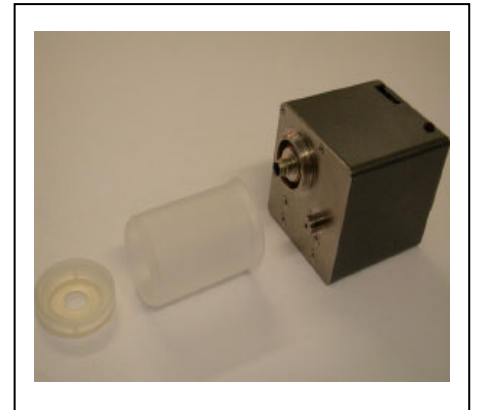

2.4 DATA Acquisition Electronics (DAE) and Measurement Server

The data acquisition electronics (DAE) consists of a highly sensitive electrometer-grade preamplifier with auto-zeroing, a channel and gain-switching multiplexer, a fast 16 bit AD-converter and a command decoder and control logic unit. Transmission to the measurement server is accomplished through an optical downlink for data and status information as well as an optical uplink for commands and the clock. The input impedance of the DAE4 is 200M Ohm; the inputs are symmetrical and floating. Common mode rejection is above 80dB.



The DASY5 measurement server is based on a PC/104 CPU board with a 400MHz intel ULV Celeron, 128MB chipdisk and 128MB RAM. The necessary circuits for communication with the DAE electronics box, as well as the 16 bit AD converter system for optical detection and digital I/O interface are contained on the DASY5 I/O board, which is directly connected to the PC/104 bus of the CPU board.



2.5 Robot

The DASY5 system uses the high precision robots TX90 XL type out of the newer series from Stäubli SA (France). For the 6-axis controller DASY5 system, the CS8C robot controller version from Stäubli is used.

The XL robot series have many features that are important for our application:

- High precision (repeatability 0.02 mm)
- High reliability (industrial design)
- Jerk-free straight movements
- Low ELF interference (the closed metallic construction shields against motor control fields)
- 6-axis controller



2.6 Light Beam Unit

The light beam switch allows automatic "tooling" of the probe. During the process, the actual position of the probe tip with respect to the robot arm is measured, as well as the probe length and the horizontal probe offset. The software then corrects all movements, such that the robot coordinates are valid for the probe tip.

The repeatability of this process is better than 0.1 mm. If a position has been taught with an aligned probe, the same position will be reached with another aligned probe within 0.1 mm, even if the other probe has different dimensions. During probe rotations, the probe tip will keep its actual position.



2.7 Device Holder

The DASY5 device holder is designed to cope with different positions given in the standard. It has two scales for the device rotation (with respect to the body axis) and the device inclination (with respect to the line between the ear reference points). The rotation center for both scales is the ear reference point (EPR).

Thus the device needs no repositioning when changing the angles.

The DASY5 device holder has been made out of low-loss POM material having the following dielectric parameters: relative permittivity $\epsilon_r = 3$ and loss tangent $\delta = 0.02$. The amount of dielectric material has been reduced in the closest vicinity of the device, since measurements have suggested that the influence of the clamp on the test results could thus be lowered.



2.8 SAM Twin Phantom

The SAM twin phantom is a fiberglass shell phantom with 2mm shell thickness (except the ear region where shell thickness increases to 6mm). It has three measurement areas:

- Left head
- Right head
- Flat phantom



The bottom plate contains three pair of bolts for locking the device holder. The device holder positions are adjusted to the standard measurement positions in the three sections. A white cover is provided to tap the phantom during off-periods to prevent water evaporation and changes in the liquid parameters. On the phantom top, three reference markers are provided to identify the phantom position with respect to the robot.

3. Tissue Simulating Liquid

3.1 The composition of the tissue simulating liquid

The following tissue formulation is for reference only. The composition of the ingredients may be modified accordingly to achieve the target tissue parameters required for routine SAR evaluation.

INGREDIENT (% Weight)	750MHz Head	1750MHz Head	1950MHz Head	2450MHz Head	2600MHz Head	5GHz Head
Water	40.45	52.55	54.90	46.70	44.53	68.29
Salt	1.45	0.34	0.18	0	0.17	0
Sugar	57.60	0	0	0	0	0
HEC	0.40	0	0	0	0	0
Preventol	0.10	0	0	0	0	0
DGBE	0	47.50	44.92	53.30	55.30	2.44
Triton X-100	0	0	0	0	0	29.27

3.2 Tissue Calibration Result

The dielectric parameters of the liquids were verified prior to the SAR evaluation, using Dielectric Probe Kit and Vector Network Analyzer.

Head Tissue Simulate Measurement				
Frequency [MHz]	Description	Dielectric Parameters		Tissue Temp. [°C]
		ϵ_r	σ [s/m]	
750 MHz	Reference result ± 5% window	41.9 39.81 to 44	0.89 0.85 to 0.93	N/A
	18-Dec-22	41.86	0.88	22.1
704 MHz	Channel 23060	42.33	0.87	22.1
707.5 MHz	Channel 23095	42.28	0.87	22.1
711 MHz	Channel 23130	42.24	0.88	22.1
782 MHz	Channel 23230	41.32	0.89	22.1
826.4 MHz	Channel 4132	40.75	0.91	22.1
831.5 MHz	Channel 26865	40.69	0.91	22.1
836.5 MHz	Channel 26915	40.62	0.91	22.1
836.6 MHz	Channel 4183	40.62	0.91	22.1
841.5 MHz	Channel 26965	40.56	0.92	22.1
846.6 MHz	Channel 4233	40.49	0.92	22.1

Head Tissue Simulate Measurement				
Frequency [MHz]	Description	Dielectric Parameters		Tissue Temp. [°C]
		ϵ_r	σ [s/m]	
750 MHz	Reference result ± 5% window	41.9 39.81 to 44	0.89 0.85 to 0.93	N/A
	27-Dec-22	41.88	0.87	22.2
824.2 MHz	Channel 128	40.95	0.89	22.2
836.4 MHz	Channel 189	40.81	0.89	22.2
848.8 MHz	Channel 251	40.65	0.90	22.2

Head Tissue Simulate Measurement				
Frequency [MHz]	Description	Dielectric Parameters		Tissue Temp. [°C]
		ϵ_r	σ [s/m]	
1750MHz	Reference result ± 5% window	40.1 38.1 to 42.11	1.37 1.30 to 1.44	N/A
	27-Dec-22	39.59	1.37	22.2
1712.4 MHz	Channel 1312	39.93	1.36	22.2
1720 MHz	Channel 132072	39.86	1.37	22.2
1732.6 MHz	Channel 1413	39.75	1.37	22.2
1745 MHz	Channel 132322	39.63	1.37	22.2
1752.6 MHz	Channel 1513	39.56	1.38	22.2
1770 MHz	Channel 132572	39.41	1.38	22.2

Head Tissue Simulate Measurement				
Frequency [MHz]	Description	Dielectric Parameters		Tissue Temp. [°C]
		ϵ_r	σ [s/m]	
1950MHz	Reference result ± 5% window	40 38 to 42	1.4 1.33 to 1.47	N/A
	17-Dec-22	39.54	1.39	21.7
1852.4 MHz	Channel 9262	40.47	1.36	21.7
1860 MHz	Channel 26140	40.41	1.36	21.7
1880 MHz	Channel 9400	40.21	1.37	21.7
1882.5 MHz	Channel 26365	40.18	1.37	21.7
1905 MHz	Channel 26590	39.54	1.38	21.7
1907.6 MHz	Channel 9538	39.94	1.38	21.7

Head Tissue Simulate Measurement				
Frequency [MHz]	Description	Dielectric Parameters		Tissue Temp. [°C]
		ϵ_r	σ [s/m]	
1950MHz	Reference result ± 5% window	40 38 to 42	1.4 1.33 to 1.47	N/A
	27-Dec-22	38.81	1.42	22.2
1850.2 MHz	Channel 512	39.11	1.40	22.2
1880 MHz	Channel 661	39.02	1.41	22.2
1909.8 MHz	Channel 810	38.96	1.41	22.2

Head Tissue Simulate Measurement				
Frequency [MHz]	Description	Dielectric Parameters		Tissue Temp. [°C]
		ϵ_r	σ [s/m]	
2450 MHz	Reference result ± 5% window	39.2 37.24 to 41.16	1.8 1.71 to 1.89	N/A
	12-Dec-22	39.98	1.79	21.9
2402 MHz	Channel 0	40.16	1.73	21.9
2412 MHz	Channel 1	40.13	1.74	21.9
2437 MHz	Channel 6	40.03	1.77	21.9
2462 MHz	Channel 11	39.94	1.81	21.9

Head Tissue Simulate Measurement				
Frequency [MHz]	Description	Dielectric Parameters		Tissue Temp. [°C]
		ϵ_r	σ [s/m]	
2600 MHz	Reference result ± 5% window	39 37.05 to 40.95	1.96 1.86 to 2.06	N/A
	17-Dec-22	38.01	1.95	21.7
2510 MHz	Channel 20850	38.97	1.91	21.7
2535 MHz	Channel 21100	38.67	1.92	21.7
2560 MHz	Channel 21350	38.38	1.93	21.7
2555 MHz	Channel 40240	38.44	1.93	21.7
2593 MHz	Channel 40620	38.09	1.95	21.7
2645 MHz	Channel 41140	37.89	1.97	21.7

Head Tissue Simulate Measurement				
Frequency [MHz]	Description	Dielectric Parameters		Tissue Temp. [°C]
		ϵ_r	σ [s/m]	
5250MHz	Reference result ± 5% window	35.95 34.15 to 37.75	4.71 4.47 to 4.95	N/A
	10-Dec-22	35.96	4.58	21.8
5210 MHz	Channel 42	36.07	4.53	21.8
5290 MHz	Channel 58	35.85	4.64	21.8

Head Tissue Simulate Measurement				
Frequency [MHz]	Description	Dielectric Parameters		Tissue Temp. [°C]
		ϵ_r	σ [s/m]	
5600MHz	Reference result ± 5% window	35.5 33.73 to 37.28	5.07 4.82 to 5.32	N/A
	10-Dec-22	34.99	5.06	21.8
5530 MHz	Channel 106	35.18	4.97	21.8
5610 MHz	Channel 122	34.96	5.07	21.8
5690 MHz	Channel 138	34.75	5.17	21.8

Head Tissue Simulate Measurement				
Frequency [MHz]	Description	Dielectric Parameters		Tissue Temp. [°C]
		ϵ_r	σ [s/m]	
5800MHz	Reference result ± 5% window	35.3 33.54 to 37.07	5.27 5.01 to 5.53	N/A
	10-Dec-22	34.44	5.32	21.8
5775 MHz	Channel 155	34.51	5.29	21.8

3.3 Tissue Dielectric Parameters for Head and Body Phantoms

The head tissue dielectric parameters recommended by the IEC 62209-1 have been incorporated in the following table. These head parameters are derived from planar layer models simulating the highest expected SAR for the dielectric properties and tissue thickness variations in a human head. Other head tissue parameters that have not been specified are interpolated according to the head parameters specified in IEC 62209-1

Target Frequency (MHz)	Head	
	ϵ_r	σ (S/m)
300	45.3	0.87
450	43.5	0.87
750	41.9	0.89
835	41.5	0.90
900	41.5	0.97
1450	40.5	1.20
1640	40.2	1.31
1750	40.1	1.37
1800 – 2000	40.0	1.40
2450	39.2	1.80
3000	38.5	2.40
5000	36.2	4.45
5200	36.0	4.66
5400	35.8	4.86
5600	35.3	5.27
5800	35.3	5.27
6000	35.1	5.48

(ϵ_r = relative permittivity, σ = conductivity and $\rho = 1000 \text{ kg/m}^3$)

4. SAR Measurement Procedure

4.1 SAR System Check

4.1.1 Dipoles

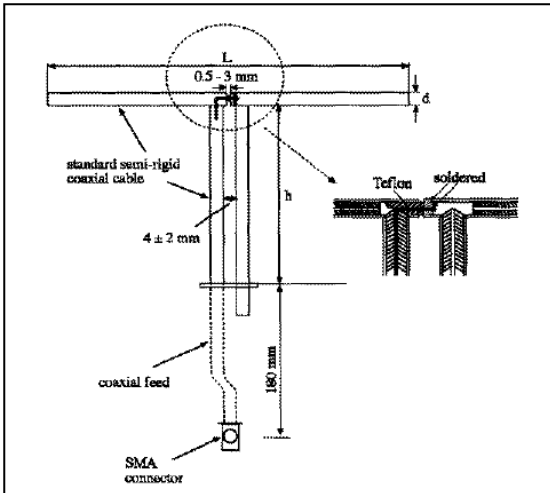

The dipoles used is based on the IEEE-1528 standard, and is complied with mechanical and electrical specifications in line with the requirements of both IEEE and FCC Supplement C. the table below provides details for the mechanical and electrical specifications for the dipoles.

Frequency	L (mm)	h (mm)	d (mm)
750MHz	176.0	100.0	6.35
1750MHz	75.2	42.9	3.6
1950MHz	66.3	38.5	3.6
2300MHz	55.5	32.6	3.6
2450MHz	51.5	30.4	3.6
2600MHz	48.5	28.8	3.6
5200M~5800MHz	20.6	40.3	3.6

4.1.2 System Check Result

System Performance Check at 750MHz, 1750MHz, 1950MHz				
Dipole Kit: D750V3				
Frequency [MHz]	Description	SAR [w/kg] 1g	SAR [w/kg] 10g	Tissue Temp. [°C]
750 MHz	Reference result ± 10% window	8.58 7.72 to 9.44	5.61 5.05 to 6.17	N/A
	18-Dec-22	8.16	5.32	22.1
	27-Dec-22	8.36	5.16	22.2
Dipole Kit: D1750V2				
Frequency [MHz]	Description	SAR [w/kg] 1g	SAR [w/kg] 10g	Tissue Temp. [°C]
1750 MHz	Reference result ± 10% window	36.7 33.03 to 40.37	19.3 17.37 to 21.23	N/A
	27-Dec-22	34.76	18.28	22.2
Dipole Kit: D1950V3				
Frequency [MHz]	Description	SAR [w/kg] 1g	SAR [w/kg] 10g	Tissue Temp. [°C]
1950 MHz	Reference result ± 10% window	40.1 36.09 to 44.11	20.8 18.72 to 22.88	N/A
	17-Dec-22	42	21.76	21.7
	27-Dec-22	40.4	21.24	22.2
Note: (1) The power level is used 250mW (2) All SAR values are normalized to 1W forward power. (3) The reference result is from Appendix E.				

System Performance Check at 2450MHz, 2600MHz
Dipole Kit: D2450V2

Frequency [MHz]	Description	SAR [w/kg] 1g	SAR [w/kg] 10g	Tissue Temp. [°C]
2450 MHz	Reference result ± 10% window	53.1 47.79 to 58.41	24.8 22.32 to 27.28	N/A
	12-Dec-22	53.2	24.32	21.9

Dipole Kit: D2600V2

Frequency [MHz]	Description	SAR [w/kg] 1g	SAR [w/kg] 10g	Tissue Temp. [°C]
2600 MHz	Reference result ± 10% window	54.50 49.05 to 59.95	24.60 22.14 to 27.06	N/A
	17-Dec-22	58.4	25.92	21.7

Note: (1) The power level is used 250mW
 (2) All SAR values are normalized to 1W forward power.
 (3) The reference result is from Appendix E.

System Performance Check at 5250MHz, 5600MHz and 5800MHz
Dipole Kit: D5GHzV2

Frequency [MHz]	Description	SAR [w/kg] 1g	SAR [w/kg] 10g	Tissue Temp. [°C]
5250 MHz	Reference result ± 10% window	81.6 73.44 to 89.76	23.2 20.88 to 25.52	N/A
	10-Dec-22	84.2	23.9	21.8
Frequency [MHz]	Description	SAR [w/kg] 1g	SAR [w/kg] 10g	Tissue Temp. [°C]
5600 MHz	Reference result ± 10% window	85.9 77.31 to 94.49	24.2 21.78 to 26.62	N/A
	10-Dec-22	89.8	25.3	21.8
Frequency [MHz]	Description	SAR [w/kg] 1g	SAR [w/kg] 10g	Tissue Temp. [°C]
5800 MHz	Reference result ± 10% window	82.0 73.80 to 90.20	22.8 20.52 to 25.08	N/A
	10-Dec-22	86.8	24.5	21.8

Note: (1) The power level is used 100mW

(2) All SAR values are normalized to 1W forward power.

(3) The reference result is from Appendix E.

4.2 SAR Measurement Procedure

The Dasy5 calculates SAR using the following equation,

$$SAR = \frac{\sigma |E|^2}{\rho}$$

σ : represents the simulated tissue conductivity

ρ : represents the tissue density

The EUT is set to transmit at the required power in line with product specification, at each frequency relating to the LOW, MID, and HIGH channel settings.

Pre-scans are made on the device to establish the location for the transmitting antenna, using a large area scan in either air or tissue simulation fluid.

The EUT is placed against the Universal Phantom where the maximum area scan dimensions are larger than the physical size of the resonating antenna. When the scan size is not large enough to cover the peak SAR distribution, it is modified by either extending the area scan size in both the X and Y directions, or the device is shifted within the predefined area.

The area scan is then run to establish the peak SAR location (interpolated resolution set at 1mm²) which is then used to orient the center of the zoom scan. The zoom scan is then executed and the 1g and 10g averages are derived from the zoom scan volume (interpolated resolution set at 1mm³).

5. SAR Exposure Limits

SAR assessments have been made in line with the requirements of IEEE-1528, FCC Supplement C, and comply with ANSI/IEEE C95.1-1992 “Uncontrolled Environments” limits. These limits apply to a location which is deemed as “Uncontrolled Environment” which can be described as a situation where the general public may be exposed to an RF source with no prior knowledge or control over their exposure.

Limits for General Population/Uncontrolled Exposure (W/kg)

Type Exposure	Uncontrolled Environment Limit
Spatial Peak SAR (1g cube tissue for brain or body)	1.60 W/kg
Spatial Average SAR (whole body)	0.08 W/kg
Spatial Peak SAR (10g for hands, feet, ankles and wrist)	4.00 W/kg

6. Test Equipment List

Instrument	Manufacturer	Model No.	Serial No.	Last Calibration	Next Calibration
Reference Dipole 750MHz	Speag	D750V3	1031	2020/05/27	2023/05/26
Reference Dipole 1750MHz	Speag	D1750V2	1113	2022/11/21	2025/11/20
Reference Dipole 1950MHz	Speag	D1950V3	1213	2022/11/18	2025/11/17
Reference Dipole 2600MHz	Aprel	ALS-D-2600-S-2	QTK-225	2022/05/25	2025/05/24
Reference Dipole 2450MHz	Speag	D2450V2	1053	2021/02/10	2024/02/09
Reference Dipole 5GHz	Speag	D5GHzV2	1041	2020/05/25	2023/05/24
Device Holder	Speag	N/A	N/A	N/A	N/A
Data Acquisition Electronic	Speag	DAE4	1425	2022/11/23	2023/11/22
E-Field Probe	Speag	EX3DV4	3979	2022/11/23	2023/11/22
Power Amplifier	Mini-Circuit	ZHL-42	D051404-20	N/A	N/A
Power Amplifier	Mini-Circuit	ZVE-8G+	447202211	N/A	N/A
Directional Coupler	Agilent	87300C	MY44300353	N/A	N/A ¹
Attenuator	Woken	WATT-218FS-10	N/A	N/A	N/A ¹
Attenuator	Mini-Circuit	BW-S20W2+	N/A	N/A	N/A ¹
Universal Radio Communication	R&S	CMU200	113574	2022/06/06	2023/06/05
Universal Radio Communication	Anritsu	MT8820C	6201465467	2022/08/10	2023/08/09
Vector Network Analyzer	Agilent	E5071C	MY46108013	2022/02/25	2023/02/24
Signal Generator	Anritsu	MG3694A	041902	2022/08/30	2023/08/29
Power Meter	Anritsu	ML2487A	6K00001447	2022/10/31	2023/10/30
Power Sensor	Anritsu	MA2411B	1339194	2022/10/31	2023/10/30

Note: 1. System Check, the path loss measured by the network analyzer, includes the signal generator, amplifier, cable, attenuator and directional coupler.

Note:

Per KDB 865664 D01 requirements for dipole calibration, the following are recommended FCC procedures for SAR dipole calibration.

1. After a dipole is damaged and properly repaired to meet required specifications
2. When the measured SAR deviates from the calibrated SAR value by more than 10% due to changes in physical, mechanical, electrical or other relevant dipole conditions;
3. When the most recent return-loss, measured at least annually, deviates by more than 20% from the previous measurement (i.e. 0.2 of the dB value) or not meeting the required -20 dB return-loss specification

	Frequency	Tissue	Return loss	Limit	Date
Calibration	750 MHz	Head	-27.8	Within 20%	2020/5/27
Measurement	750 MHz	Head	-24.15		2021/5/26
Measurement	750 MHz	Head	-24.02		2022/5/25

	Frequency	Tissue	Return loss	Limit	Date
Calibration	2450 MHz	Head	-24.2	Within 20%	2021/2/10
Measurement	2450 MHz	Head	-24.69		2022/2/14

	Frequency	Tissue	Return loss	Limit	Date
Calibration	5250 MHz	Head	-26.9	Within 20%	2020/5/25
Measurement	5250 MHz	Head	-24.16		2021/5/18
Measurement	5250 MHz	Head	-25.46		2022/5/17

	Frequency	Tissue	Return loss	Limit	Date
Calibration	5600 MHz	Head	-24.4	Within 20%	2020/5/25
Measurement	5600 MHz	Head	-27.05		2021/5/18
Measurement	5600 MHz	Head	-24.46		2022/5/17

	Frequency	Tissue	Return loss	Limit	Date
Calibration	5800 MHz	Head	-26.8	Within 20%	2020/5/25
Measurement	5800 MHz	Head	-25.64		2021/5/18
Measurement	5800 MHz	Head	-24.88		2022/5/17

4. When the most recent measurement of the real or imaginary parts of the impedance, measured at least annually, deviates by more than 5 Ω from the previous measurement

	Frequency	Tissue	Impedance	Limit	Date
Calibration	750 MHz	Head	53.8	Within 5Ω	2020/5/27
Measurement	750 MHz	Head	50.62		2021/5/26
Measurement	750 MHz	Head	51.49		2022/5/25

	Frequency	Tissue	Impedance	Limit	Date
Calibration	2450 MHz	Head	52.7	Within 5Ω	2021/2/10
Measurement	2450 MHz	Head	53.26		2022/2/14

	Frequency	Tissue	Impedance	Limit	Date
Calibration	5250 MHz	Head	49.0	Within 5Ω	2020/5/25
Measurement	5250 MHz	Head	45.54		2021/5/18
Measurement	5250 MHz	Head	50.45		2022/5/17

	Frequency	Tissue	Impedance	Limit	Date
Calibration	5600 MHz	Head	56.3	Within 5Ω	2020/5/25
Measurement	5600 MHz	Head	52.24		2021/5/18
Measurement	5600 MHz	Head	55.41		2022/5/17

	Frequency	Tissue	Impedance	Limit	Date
Calibration	5800 MHz	Head	54.3	Within 5Ω	2020/5/25
Measurement	5800 MHz	Head	49.85		2021/5/18
Measurement	5800 MHz	Head	56.96		2022/5/17

7. Measurement Uncertainty

Measurement uncertainty for 30 MHz to 3 GHz								
Error Description	Uncert. value	Prob. Dist.	Div.	(ci) 1g	(ci) 10g	Std. Unc. (1g)	Std. Unc. (10g)	(Vi) Veff
Measurement System								
Probe Calibration	±6%	N	1	1	1	±6.0%	±6.0%	∞
Axial Isotropy	±4.7%	R	√3	0.7	0.7	±1.9%	±1.9%	∞
Hemispherical Isotropy	±9.6%	R	√3	0.7	0.7	±3.9%	±3.9%	∞
Boundary Effects	±1.0%	R	√3	1	1	±0.6%	±0.6%	∞
Linearity	±4.7%	R	√3	1	1	±2.7%	±2.7%	∞
System Detection Limits	±1.0%	R	√3	1	1	±0.6%	±0.6%	∞
Modulation Response	±2.4%	R	√3	1	1	±1.4%	±1.4%	∞
Readout Electronics	±0.3%	N	1	1	1	±0.3%	±0.3%	∞
Response Time	±0.8%	R	√3	1	1	±0.5%	±0.5%	∞
Integration Time	±2.6%	R	√3	1	1	±1.5%	±1.5%	∞
RF Ambient Noise	±3.0%	R	√3	1	1	±1.7%	±1.7%	∞
RF Ambient Reflections	±3.0%	R	√3	1	1	±1.7%	±1.7%	∞
Probe Positioner	±0.4%	R	√3	1	1	±0.2%	±0.2%	∞
Probe Positioning	±2.9%	R	√3	1	1	±1.7%	±1.7%	∞
Max. SAR Eval.	±4.0%	R	√3	1	1	±1.2%	±1.2%	∞
Test Sample Related								
Device Positioning	±2.9%	N	1	1	1	±2.9%	±2.9%	145
Device Holder	±3.6%	N	1	1	1	±3.6%	±3.6%	5
Power Drift	±5.0%	R	√3	1	1	±2.9%	±2.9%	∞
Power Scaling	±0%	R	√3	1	1	±0.0%	±0.0%	
Phantom and Setup								
Phantom Uncertainty	±6.1%	R	√3	1	1	±3.5%	±3.5%	∞
SAR correction	±1.9%	R	√3	1	0.84	±1.1%	±0.9%	∞
Liquid Conductivity (meas.)	±2.5%	R	√3	0.78	0.71	±1.1%	±1.0%	∞
Liquid Permittivity (meas.)	±2.5%	R	√3	0.26	0.26	±0.3%	±0.4%	∞
Temp. unc. - Conductivity	±3.4%	R	√3	0.78	0.71	±1.5%	±1.4%	∞
Temp. unc. - Permittivity	±0.4%	R	√3	0.23	0.26	±0.1%	±0.1%	∞
Combined Std. Uncertainty						±11.2%	±11.1%	361
Expanded STD Uncertainty						±22.3%	±22.2%	

Measurement uncertainty for 3GHz to 6 GHz								
Error Description	Uncert. value	Prob. Dist.	Div.	(ci) 1g	(ci) 10g	Std. Unc. (1g)	Std. Unc. (10g)	(Vi) Veff
Measurement System								
Probe Calibration	±6.55%	N	1	1	1	±6.55%	±6.55%	∞
Axial Isotropy	±4.7%	R	√3	0.7	0.7	±1.9%	±1.9%	∞
Hemispherical Isotropy	±9.6%	R	√3	0.7	0.7	±3.9%	±3.9%	∞
Boundary Effects	±2.0%	R	√3	1	1	±1.2%	±1.2%	∞
Linearity	±4.7%	R	√3	1	1	±2.7%	±2.7%	∞
System Detection Limits	±1.0%	R	√3	1	1	±0.6%	±0.6%	∞
Modulation Response	±2.4%	R	√3	1	1	±1.4%	±1.4%	∞
Readout Electronics	±0.3%	N	1	1	1	±0.3%	±0.3%	∞
Response Time	±0.8%	R	√3	1	1	±0.5%	±0.5%	∞
Integration Time	±2.6%	R	√3	1	1	±1.5%	±1.5%	∞
RF Ambient Noise	±3.0%	R	√3	1	1	±1.7%	±1.7%	∞
RF Ambient Reflections	±3.0%	R	√3	1	1	±1.7%	±1.7%	∞
Probe Positioner	±0.8%	R	√3	1	1	±0.5%	±0.5%	∞
Probe Positioning	±6.7%	R	√3	1	1	±3.9%	±3.9%	∞
Post-processing	±4.0%	R	√3	1	1	±2.3%	±2.3%	∞
Test Sample Related								
Device Positioning	±2.9%	N	1	1	1	±2.9%	±2.9%	145
Device Holder	±3.6%	N	1	1	1	±3.6%	±3.6%	5
Power Drift	±5.0%	R	√3	1	1	±2.9%	±2.9%	∞
Power Scaling	±0%	R	√3	1	1	±0.0%	±0.0%	
Phantom and Setup								
Phantom Uncertainty	±6.6%	R	√3	1	1	±3.8%	±3.8%	∞
SAR correction	±1.9%	R	√3	1	1	±1.1%	±0.9%	∞
Liquid Conductivity (meas.)	±2.5%	R	√3	1	0.84	±1.1%	±1.0%	∞
Liquid Permittivity (meas.)	±2.5%	R	√3	0.26	0.26	±0.3%	±0.4%	∞
Temp. unc. - Conductivity	±3.4%	R	√3	0.78	0.71	±1.5%	±1.4%	∞
Temp. unc. - Permittivity	±0.4%	R	√3	0.23	0.26	±0.1%	±0.1%	∞
Combined Std. Uncertainty						±12.3%	±12.2%	748
Expanded STD Uncertainty						±24.6%	±24.5%	

8. Conducted Power Measurement (Including tolerance allowed for production unit)

Mode		Maximum Output Power (dBm) (Including tolerance)
WLAN 2.4GHz	DTS	18
WLAN 5GHz	NII	14.5
Bluetooth	BR	8
GSM850	VOICE	34
	GPRS Class 8	34
	GPRS Class 10	32.5
	GPRS Class 11	31
	GPRS Class 12	30
PCS1900	VOICE	30.5
	GPRS Class 8	30.5
	GPRS Class 10	30
	GPRS Class 11	29
	GPRS Class 12	28
WCDMA B2	RMC	24
	HSDPA	22.5
	HSUPA	21.5
WCDMA B4	RMC	19
	HSDPA	19
	HSUPA	18.5
WCDMA B5	RMC	25
	HSDPA	23
	HSUPA	22.5
LTE Band 2	QPSK	23
LTE Band 4	QPSK	19
LTE Band 5	QPSK	24
LTE Band 7	QPSK	20
LTE Band 12	QPSK	24.5
LTE Band 13	QPSK	24.5
LTE Band 17	QPSK	24.5
LTE Band 25	QPSK	23
LTE Band 26	QPSK	24
LTE Band 38	QPSK	23
LTE Band 41	QPSK	23
LTE Band 66	QPSK	19

WLAN 2.4G 1TX SISO						
DSSS/OFDM mode specified maximum output power at an antenna port	Frequency	Mode	BW	SISO-Main(TX1)		
				CH	AV Power	AV Target
	WLAN 2.4GHz	b	20	1	17.88	18
6				17.92	18	
11				17.85	18	
g			20	1	17.85	18
				6	17.89	18
				11	17.82	18
n (HT)			20	1	17.83	18
				6	17.87	18
				11	17.79	18
		40	3	15.66	16	
			6	17.81	18	
			9	16.16	16.5	

WLAN 5G 1TX SISO													
OFDM mode specified maximum output power at an antenna port	Frequency	Mode	BW	SISO-Main(TX1)			Frequency	Mode	BW	SISO-Main(TX1)			
				CH	AV	AV				CH	AV	AV	
					Power	Target					Power	Target	
OFDM mode specified maximum output power at an antenna port	U-NII-1 (5150~5250MHz)	a	20	36	14.26	14.5	U-NII-2C (5470~5725MHz)	a	20	100	14.21	14.5	
				40	14.13	14.5				112	14.06	14.5	
				44	14.24	14.5				116	14.40	14.5	
				48	14.29	14.5				128	14.06	14.5	
		n (HT)	20	36	14.28	14.5		n	20	100	14.25	14.5	
				40	13.93	14.5				112	14.02	14.5	
				44	14.26	14.5				116	14.41	14.5	
				48	14.23	14.5				128	14.02	14.5	
		ac(VHT)	80	38	14.23	14.5		n (HT)	20	132	13.93	14.5	
				46	14.19	14.5				102	14.22	14.5	
				42	14.43	14.5				110	14.28	14.5	
				42	14.43	14.5				118	13.92	14.5	
	U-NII-2A (5250~5350MHz)	a	20	52	14.27	14.5	U-NII-2C (5470~5725MHz)	ac	40	126	14.03	14.5	
				56	14.06	14.5				134	14.22	14.5	
				60	14.26	14.5				144	14.07	14.5	
				64	14.24	14.5				40	142	14.03	14.5
		n (HT)	20	52	14.27	14.5		ac (VHT)	80	106	14.31	14.5	
				56	13.94	14.5				122	14.43	14.5	
				60	14.23	14.5				138	14.43	14.5	
				64	14.28	14.5							
		ac	80	54	14.16	14.5		U-NII-3 (5725~5850MHz)	a	20	149	14.27	14.5
				62	14.22	14.5					157	14.28	14.5
				58	14.44	14.5					165	14.27	14.5
				58	14.44	14.5					149	14.26	14.5
ac(VHT)	80	58	14.44	14.5	n (HT)	20	157		14.24	14.5			
		58	14.44	14.5			165		14.20	14.5			
		58	14.44	14.5			151		14.21	14.5			
		58	14.44	14.5			159		14.25	14.5			
		58	14.44	14.5			155		14.38	14.5			
		58	14.44	14.5			155		14.38	14.5			

BT						
Bluetooth mode maximum output power	Frequency	Mode	Modulation	SISO-Main(TX1)		
				CH	AV Power	AV Target
	BT 2.4GHz	BR	GFSK	0	7.51	8.0
				39	5.38	5.5
				78	7.44	8.0
		EDR	8DPSK	0	5.12	5.5
				39	2.63	3.0
				78	5.20	5.5
		BLE	GFSK	0	2.89	3.0
				19	0.78	1.0
				39	4.10	4.5

Band	GSM850			PCS1900		
CHANNEL	128	189	251	512	661	810
VOICE	32.77	32.79	32.75	30.47	30.50	30.32
GPRS Class 8	32.75	32.78	32.65	30.41	30.45	30.15
GPRS Class 10	31.01	31.21	31.02	29.77	29.84	29.78
GPRS Class 11	29.66	29.85	29.84	28.23	28.32	28.21
GPRS Class 12	29.59	29.61	29.55	27.37	27.38	27.17
EGPRS Class 8	25.17	25.58	25.39	23.94	23.95	23.82
EGPRS Class 10	22.64	23.23	23.01	23.9	23.91	23.78
EGPRS Class 11	19.94	20.59	20.27	22.05	22.1	22.04
EGPRS Class 12	18.17	18.73	18.51	20.61	20.63	20.14

Note: Unit : dBm

Band	WCDMA B2			WCDMA B4			WCDMA B5		
CHANNEL	9262	9400	9538	1312	1413	1513	4132	4183	4233
VOICE	22.31	22.52	22.41	18.44	18.77	18.61	22.57	22.63	22.58
RMC	22.37	22.65	22.46	18.54	18.83	18.72	23.03	23.12	23.01
HSDPA Set 1	20.59	21.22	20.9	18.19	18.62	18.5	21.54	21.6	21.55
HSDPA Set 2	20.6	21.05	20.89	18.2	18.52	18.4	21.5	21.61	21.56
HSDPA Set 3	20.61	21.05	20.89	18.21	18.51	18.39	21.48	21.61	21.55
HSDPA Set 4	20.66	21.04	20.83	18.25	18.54	18.42	21.48	21.64	21.43
HSUPA Set 1	20.22	20.76	20.25	17.93	18.30	18.05	21.01	21.14	20.99
HSUPA Set 2	20.05	20.56	20.31	17.73	18.18	18.04	20.83	21.12	20.93
HSUPA Set 3	20.28	20.45	20.34	17.86	18.4	17.99	20.9	21.02	21.02
HSUPA Set 4	19.96	20.69	20.31	17.77	18.22	18.1	20.87	20.99	20.94
HSUPA Set 5	20.21	20.52	20.3	17.87	18.3	18.08	20.64	21.09	20.75

Note: Unit : dBm

Channel	Modulation	LTE Band 2							
		RB	RB	Maximum Conducted Output Power					
		No.	Offset	1.4M	3M	5M	10M	15M	20M
Low	QPSK	1	#0	21.49	21.40	21.53	21.51	21.52	21.31
		1	#Mid	21.66	21.55	21.87	21.79	21.54	21.88
		1	#Max	21.46	21.45	21.49	21.48	21.48	21.33
		50%	#0	20.64	20.66	20.67	20.61	20.59	20.64
		50%	#Mid	20.62	20.67	20.68	20.60	20.57	20.58
		50%	#Max	20.57	20.62	20.63	20.57	20.49	20.47
		100%	--	20.63	20.59	20.64	20.62	20.52	20.52
	16QAM	1	#0	20.75	20.78	20.44	20.56	20.28	20.79
		1	#Mid	20.43	20.39	20.34	20.49	20.25	20.43
		1	#Max	20.28	20.68	20.20	20.43	20.12	20.48
		50%	#0	20.59	19.56	19.70	19.67	19.63	19.66
		50%	#Mid	20.72	19.75	19.68	19.85	19.59	19.69
		50%	#Max	20.69	19.91	19.57	19.93	19.53	19.49
		100%	--	19.55	19.64	19.70	19.65	19.68	19.53
	64QAM	1	#0	19.69	19.59	19.58	19.59	19.76	18.69
		1	#Mid	19.92	19.96	19.82	20.08	19.92	20.06
		1	#Max	19.85	19.53	19.40	19.56	19.15	19.59
		50%	#0	19.63	18.71	18.72	18.76	18.74	18.58
		50%	#Mid	19.51	18.62	18.72	18.74	18.62	18.55
		50%	#Max	19.52	18.57	18.69	18.63	18.71	18.61
		100%	--	18.42	18.69	18.76	18.66	18.48	18.63
Mid	QPSK	1	#0	21.76	21.64	21.84	21.56	21.79	21.48
		1	#Mid	22.09	21.88	22.26	22.14	22.05	22.28
		1	#Max	21.82	21.68	21.93	21.71	21.74	21.75
		50%	#0	20.87	20.82	21.07	20.87	20.82	20.87
		50%	#Mid	20.82	20.87	21.09	20.87	20.82	20.80
		50%	#Max	20.77	20.81	21.10	20.79	20.88	20.89
		100%	--	20.89	20.91	21.04	20.83	20.79	20.83
	16QAM	1	#0	20.91	20.95	20.93	20.79	20.70	20.69
		1	#Mid	20.59	20.61	20.66	20.76	20.50	20.56
		1	#Max	20.72	20.90	20.73	20.75	20.56	20.44
		50%	#0	20.75	19.51	19.78	20.09	19.85	19.86
		50%	#Mid	20.88	19.90	19.86	19.75	19.83	19.82

		50%	#Max	20.86	19.90	19.76	19.75	19.84	19.91	
		100%	--	19.73	19.64	19.97	19.88	19.83	19.84	
	64QAM	1	#0	19.96	19.37	19.66	19.79	19.80	19.68	
		1	#Mid	19.97	19.81	20.13	19.97	20.12	20.21	
		1	#Max	19.76	19.25	19.69	19.79	19.77	19.68	
		50%	#0	19.69	18.67	19.11	19.00	18.98	18.90	
		50%	#Mid	19.65	18.74	19.10	19.02	18.89	18.70	
		50%	#Max	19.68	18.58	18.89	18.94	18.95	18.91	
		100%	--	18.53	18.65	18.97	18.88	18.91	18.65	
	High	QPSK	1	#0	21.73	21.83	21.84	21.81	21.81	21.61
			1	#Mid	22.01	21.85	22.12	21.94	21.95	22.19
			1	#Max	21.78	21.62	21.86	21.68	21.89	21.54
			50%	#0	20.91	21.00	20.89	21.04	21.06	21.04
			50%	#Mid	20.94	20.98	20.93	21.08	21.01	20.98
50%			#Max	20.95	21.00	20.90	20.97	21.09	20.95	
100%			--	20.98	21.00	20.92	21.02	20.98	21.02	
16QAM		1	#0	21.17	20.91	20.88	21.05	20.78	20.97	
		1	#Mid	21.16	20.90	20.85	20.99	20.77	20.89	
		1	#Max	20.77	20.78	20.62	20.85	20.76	20.67	
		50%	#0	20.86	19.92	20.00	19.93	19.94	19.98	
		50%	#Mid	20.93	19.92	19.99	20.17	19.98	20.01	
		50%	#Max	21.07	19.86	19.99	19.87	19.88	19.88	
		100%	--	19.87	19.95	20.14	19.99	20.03	20.01	
64QAM		1	#0	20.26	19.96	19.82	19.95	19.95	19.86	
		1	#Mid	20.27	20.40	20.33	20.41	20.25	20.37	
		1	#Max	19.89	20.00	19.82	19.94	19.54	19.78	
		50%	#0	19.91	18.82	19.13	19.20	19.02	19.16	
		50%	#Mid	20.03	18.95	19.32	19.19	19.12	19.11	
		50%	#Max	19.99	18.74	19.10	19.09	19.11	19.08	
		100%	--	18.92	19.13	19.17	19.01	19.14	19.14	

Channel	Modulation	LTE Band 4							
		RB	RB	Maximum Conducted Output Power					
		No.	Offset	1.4M	3M	5M	10M	15M	20M
Low	QPSK	1	#0	17.97	17.61	18.02	17.69	17.74	17.72
		1	#Mid	18.10	17.90	18.26	18.01	17.98	18.15
		1	#Max	17.98	17.79	18.05	18.01	17.97	17.91
		50%	#0	16.96	16.97	16.92	16.90	17.79	16.97
		50%	#Mid	16.91	16.92	16.93	16.88	16.89	16.90
		50%	#Max	16.90	16.98	17.10	16.87	16.97	16.96
		100%	--	16.92	16.84	16.97	16.93	16.88	16.95
	16QAM	1	#0	16.33	16.70	16.13	16.39	16.43	16.86
		1	#Mid	16.85	16.80	16.34	16.97	16.50	17.10
		1	#Max	16.59	16.79	16.30	16.87	16.49	16.62
		50%	#0	16.79	15.77	15.75	15.98	15.91	15.89
		50%	#Mid	16.83	15.84	15.84	15.96	15.89	15.95
		50%	#Max	16.82	15.77	15.71	15.93	16.11	16.09
		100%	--	15.96	15.89	15.81	16.04	15.86	16.07
	64QAM	1	#0	16.09	15.95	16.51	16.09	16.28	16.16
		1	#Mid	16.25	16.02	16.61	16.59	16.43	16.66
		1	#Max	16.05	15.82	16.47	16.09	16.41	16.43
		50%	#0	16.08	14.85	15.83	15.07	14.88	15.00
		50%	#Mid	16.08	14.81	15.94	15.08	15.07	14.99
		50%	#Max	16.03	14.85	15.48	14.95	15.13	14.99
		100%	--	14.84	14.83	15.24	15.06	14.94	15.18
Mid	QPSK	1	#0	18.08	18.02	18.20	17.82	18.01	17.80
		1	#Mid	18.10	18.13	18.24	18.12	18.14	18.25
		1	#Max	17.99	17.98	18.21	17.66	18.03	17.71
		50%	#0	17.10	17.04	17.81	16.95	16.99	16.96
		50%	#Mid	17.15	17.03	17.26	16.94	17.02	16.90
		50%	#Max	17.01	16.98	17.14	16.88	16.92	16.88
		100%	--	17.00	17.06	17.07	16.91	17.00	16.98
	16QAM	1	#0	16.57	16.21	16.31	16.26	16.49	16.53
		1	#Mid	16.93	16.80	16.98	16.51	17.01	17.13
		1	#Max	16.90	16.45	16.92	16.41	16.59	16.85
		50%	#0	16.78	16.12	15.98	15.97	16.06	16.13
		50%	#Mid	16.38	16.10	15.99	16.16	16.03	16.13
		50%	#Max	16.32	16.07	15.93	16.12	15.93	16.06
		100%	--	16.21	16.10	16.06	15.87	16.04	16.01

	64QAM	1	#0	16.16	16.74	16.34	15.72	16.31	16.75
		1	#Mid	16.63	16.80	16.81	16.62	16.32	16.82
		1	#Max	16.04	16.64	16.25	15.77	15.58	15.86
		50%	#0	16.26	15.06	15.97	15.00	15.26	15.00
		50%	#Mid	16.22	15.11	15.94	15.16	15.23	15.13
		50%	#Max	16.16	15.21	15.90	15.11	15.16	14.94
		100%	--	14.93	14.96	15.08	14.96	15.07	14.93
High	QPSK	1	#0	17.83	17.85	18.12	17.75	18.11	18.10
		1	#Mid	17.93	17.86	18.22	18.11	18.12	18.23
		1	#Max	17.87	17.66	18.01	17.89	17.82	17.93
		50%	#0	17.84	17.09	17.91	17.00	16.94	17.08
		50%	#Mid	17.93	16.86	17.95	16.97	16.92	16.92
		50%	#Max	16.85	16.86	17.90	16.85	16.94	16.93
		100%	--	17.09	16.88	17.38	16.94	16.97	17.01
	16QAM	1	#0	16.63	16.23	16.31	16.99	16.80	16.92
		1	#Mid	16.97	16.86	17.16	17.09	16.85	17.17
		1	#Max	16.43	16.41	16.92	17.04	16.85	16.94
		50%	#0	16.81	16.24	15.98	16.00	16.11	16.23
		50%	#Mid	16.92	16.19	15.99	16.14	16.10	16.08
		50%	#Max	16.96	16.21	15.93	15.83	16.11	15.96
		100%	--	16.14	15.87	16.06	16.10	16.12	16.12
	64QAM	1	#0	16.40	15.75	16.34	15.70	15.78	16.79
		1	#Mid	16.41	16.13	16.81	16.52	16.13	16.89
		1	#Max	16.27	15.87	16.25	15.75	15.83	15.91
		50%	#0	15.96	14.93	15.97	15.29	15.08	15.24
		50%	#Mid	16.16	14.98	15.94	15.25	15.06	14.98
		50%	#Max	16.21	14.89	15.90	15.15	15.17	15.09
		100%	--	14.87	14.86	15.12	15.04	14.90	15.16

Channel	Modulation	LTE Band 5							
		RB	RB	Maximum Conducted Output Power					
		No.	Offset	1.4M	3M	5M	10M	15M	20M
Low	QPSK	1	#0	22.31	22.05	22.32	22.32	--	--
		1	#Mid	22.42	22.52	22.62	22.71	--	--
		1	#Max	22.31	22.01	22.33	22.41	--	--
		50%	#0	21.40	21.39	21.41	21.65	--	--
		50%	#Mid	21.28	21.35	21.46	21.60	--	--
		50%	#Max	21.29	21.29	21.30	21.59	--	--
		100%	--	21.28	21.24	21.31	21.58	--	--
	16QAM	1	#0	21.41	20.97	20.94	20.93	--	--
		1	#Mid	21.46	21.16	20.96	21.05	--	--
		1	#Max	21.32	21.10	20.84	21.02	--	--
		50%	#0	21.15	20.31	20.16	20.27	--	--
		50%	#Mid	21.40	20.42	20.26	20.22	--	--
		50%	#Max	21.36	20.58	20.22	20.57	--	--
		100%	--	20.30	20.38	20.49	20.30	--	--
	64QAM	1	#0	20.47	20.33	20.08	20.28	--	--
		1	#Mid	20.76	20.68	20.50	20.77	--	--
		1	#Max	20.69	20.25	19.66	20.20	--	--
		50%	#0	20.47	19.25	19.38	19.33	--	--
		50%	#Mid	20.36	19.19	19.46	19.38	--	--
		50%	#Max	20.40	19.14	19.23	19.27	--	--
		100%	--	19.22	19.33	19.34	19.17	--	--
Mid	QPSK	1	#0	22.16	22.21	22.37	22.36	--	--
		1	#Mid	22.51	22.61	22.66	22.75	--	--
		1	#Max	22.28	22.33	22.36	22.47	--	--
		50%	#0	21.26	21.36	21.42	21.66	--	--
		50%	#Mid	21.17	21.29	21.48	21.67	--	--
		50%	#Max	21.22	21.29	21.33	21.62	--	--
		100%	--	21.38	21.33	21.39	21.65	--	--
	16QAM	1	#0	21.38	21.25	20.98	21.14	--	--
		1	#Mid	21.43	21.49	21.11	21.56	--	--
		1	#Max	21.11	21.44	21.08	21.25	--	--
		50%	#0	21.35	20.44	20.27	20.34	--	--
		50%	#Mid	21.41	20.36	20.25	20.25	--	--
		50%	#Max	21.37	20.47	20.13	20.22	--	--
		100%	--	20.24	20.41	20.34	20.36	--	--

	64QAM	1	#0	20.34	20.07	20.21	20.31	--	--
		1	#Mid	20.52	20.39	20.78	20.71	--	--
		1	#Max	20.28	19.94	20.33	20.41	--	--
		50%	#0	20.38	19.29	19.41	19.46	--	--
		50%	#Mid	20.32	19.28	19.64	19.47	--	--
		50%	#Max	20.37	19.22	19.56	19.33	--	--
		100%	--	19.16	19.28	19.31	19.23	--	--
High	QPSK	1	#0	22.27	22.21	22.28	22.38	--	--
		1	#Mid	22.50	22.56	22.59	22.62	--	--
		1	#Max	22.20	22.04	22.21	22.22	--	--
		50%	#0	21.31	21.30	21.32	21.51	--	--
		50%	#Mid	21.32	21.26	21.35	21.50	--	--
		50%	#Max	21.24	21.25	21.30	21.41	--	--
		100%	--	21.30	21.33	21.34	21.51	--	--
	16QAM	1	#0	21.15	20.94	21.29	21.42	--	--
		1	#Mid	21.45	21.15	21.42	21.52	--	--
		1	#Max	21.32	20.95	21.40	21.40	--	--
		50%	#0	21.38	20.20	20.26	20.28	--	--
		50%	#Mid	21.44	20.47	20.28	20.22	--	--
		50%	#Max	21.41	20.45	20.37	20.13	--	--
		100%	--	20.09	20.44	20.40	20.25	--	--
	64QAM	1	#0	20.49	20.15	19.90	20.30	--	--
		1	#Mid	20.66	20.66	20.33	20.43	--	--
		1	#Max	20.40	20.27	19.97	20.38	--	--
		50%	#0	20.40	19.21	19.28	19.43	--	--
		50%	#Mid	20.42	19.17	19.52	19.25	--	--
		50%	#Max	20.35	19.24	19.41	19.20	--	--
		100%	--	19.20	19.52	19.32	19.24	--	--

Channel	Modulation	LTE Band 7							
		RB	RB	Maximum Conducted Output Power					
		No.	Offset	1.4M	3M	5M	10M	15M	20M
Low	QPSK	1	#0	--	--	18.01	18.16	18.15	18.19
		1	#Mid	--	--	18.63	18.65	18.65	19.35
		1	#Max	--	--	18.01	18.09	18.08	18.11
		50%	#0	--	--	17.49	17.50	17.49	17.57
		50%	#Mid	--	--	17.53	17.40	17.57	17.57
		50%	#Max	--	--	17.55	17.52	17.54	17.56
		100%	--	--	--	17.53	17.51	17.53	17.55
	16QAM	1	#0	--	--	17.19	17.08	17.01	17.01
		1	#Mid	--	--	17.31	17.60	17.11	17.67
		1	#Max	--	--	17.13	17.11	16.88	17.21
		50%	#0	--	--	16.38	16.53	16.45	16.15
		50%	#Mid	--	--	16.50	16.64	16.46	16.28
		50%	#Max	--	--	16.45	16.58	16.44	16.26
		100%	--	--	--	16.58	16.40	16.40	16.19
	64QAM	1	#0	--	--	16.66	16.28	16.79	17.20
		1	#Mid	--	--	16.86	16.89	16.86	17.54
		1	#Max	--	--	16.46	16.56	16.74	16.63
		50%	#0	--	--	15.59	15.70	15.62	16.34
		50%	#Mid	--	--	15.73	15.71	15.63	16.34
		50%	#Max	--	--	15.86	15.63	15.59	16.33
		100%	--	--	--	15.61	15.47	15.45	16.17
Mid	QPSK	1	#0	--	--	18.11	18.25	18.22	18.26
		1	#Mid	--	--	18.63	18.65	18.60	19.37
		1	#Max	--	--	18.04	18.39	18.33	18.54
		50%	#0	--	--	17.57	17.60	17.55	17.65
		50%	#Mid	--	--	17.50	17.60	17.45	17.61
		50%	#Max	--	--	17.51	17.50	17.58	17.61
		100%	--	--	--	17.59	17.55	17.55	17.60
	16QAM	1	#0	--	--	17.01	17.05	16.98	17.20
		1	#Mid	--	--	17.49	17.32	17.13	17.80
		1	#Max	--	--	16.50	16.36	17.09	16.86
		50%	#0	--	--	16.49	16.35	16.46	16.50
		50%	#Mid	--	--	16.32	16.29	16.26	16.38
		50%	#Max	--	--	16.26	16.30	16.24	16.35
		100%	--	--	--	16.27	16.26	16.41	16.42

	64QAM	1	#0	--	--	16.50	16.33	16.66	16.68
		1	#Mid	--	--	16.56	16.88	16.70	17.24
		1	#Max	--	--	15.99	16.60	16.69	16.83
		50%	#0	--	--	15.45	15.74	15.62	16.55
		50%	#Mid	--	--	15.74	15.81	15.61	16.50
		50%	#Max	--	--	15.53	15.63	15.65	16.46
		100%	--	--	--	15.74	15.61	15.78	16.48
High	QPSK	1	#0	--	--	18.01	18.16	18.15	18.22
		1	#Mid	--	--	18.50	18.45	18.37	19.11
		1	#Max	--	--	18.00	18.00	18.01	18.02
		50%	#0	--	--	17.46	17.51	17.39	17.59
		50%	#Mid	--	--	17.40	17.50	17.40	17.51
		50%	#Max	--	--	17.43	17.35	17.39	17.49
		100%	--	--	--	17.32	17.39	17.36	17.48
	16QAM	1	#0	--	--	17.08	17.27	17.37	17.50
		1	#Mid	--	--	17.34	17.40	17.39	17.53
		1	#Max	--	--	17.04	17.29	17.20	17.30
		50%	#0	--	--	16.44	16.36	16.34	16.48
		50%	#Mid	--	--	16.49	16.33	16.45	16.55
		50%	#Max	--	--	16.27	16.36	16.44	16.42
		100%	--	--	--	16.21	16.38	16.29	16.37
	64QAM	1	#0	--	--	16.11	16.59	16.64	16.79
		1	#Mid	--	--	16.69	16.61	16.75	16.80
		1	#Max	--	--	16.32	16.60	16.49	16.72
		50%	#0	--	--	15.59	15.63	15.63	16.31
		50%	#Mid	--	--	15.62	15.71	15.65	16.38
		50%	#Max	--	--	15.22	15.25	15.41	16.34
		100%	--	--	--	15.39	15.55	15.45	16.34

Channel	Modulation	LTE Band 12							
		RB	RB	Maximum Conducted Output Power					
		No.	Offset	1.4M	3M	5M	10M	15M	20M
Low	QPSK	1	#0	22.50	22.55	22.51	22.56	--	--
		1	#Mid	22.83	22.65	22.78	23.02	--	--
		1	#Max	22.58	22.62	22.53	22.63	--	--
		50%	#0	21.70	21.68	21.67	21.72	--	--
		50%	#Mid	21.65	21.72	21.81	21.84	--	--
		50%	#Max	21.66	21.75	21.79	21.79	--	--
		100%	--	21.68	21.66	21.78	21.80	--	--
	16QAM	1	#0	21.57	21.69	21.39	21.40	--	--
		1	#Mid	21.92	21.74	21.45	21.75	--	--
		1	#Max	21.86	21.61	21.44	21.71	--	--
		50%	#0	21.66	20.38	20.65	20.54	--	--
		50%	#Mid	21.75	20.54	20.90	20.66	--	--
		50%	#Max	21.72	20.54	20.68	20.67	--	--
		100%	--	20.57	20.75	20.61	20.59	--	--
	64QAM	1	#0	21.19	20.77	20.72	20.67	--	--
		1	#Mid	21.06	21.13	21.00	21.32	--	--
		1	#Max	20.79	20.83	20.79	20.90	--	--
		50%	#0	20.63	19.45	19.75	19.58	--	--
		50%	#Mid	20.73	19.55	19.96	19.89	--	--
		50%	#Max	20.70	19.75	19.83	19.95	--	--
		100%	--	19.56	19.66	19.93	19.79	--	--
Mid	QPSK	1	#0	22.58	22.63	22.55	22.64	--	--
		1	#Mid	22.91	22.89	23.09	23.13	--	--
		1	#Max	22.57	22.50	22.86	22.87	--	--
		50%	#0	21.73	21.79	21.73	21.81	--	--
		50%	#Mid	21.67	21.84	21.84	22.01	--	--
		50%	#Max	21.67	21.81	21.78	21.82	--	--
		100%	--	21.74	21.81	21.82	21.83	--	--
	16QAM	1	#0	21.81	21.73	21.76	21.62	--	--
		1	#Mid	22.17	21.88	21.74	22.04	--	--
		1	#Max	22.06	21.87	21.74	21.70	--	--
		50%	#0	21.62	20.78	20.62	20.72	--	--
		50%	#Mid	21.85	20.93	20.97	20.59	--	--
		50%	#Max	21.85	20.88	20.79	20.59	--	--

	64QAM	100%	--	20.58	20.47	20.89	20.70	--	--
		1	#0	21.21	20.44	20.48	20.53	--	--
		1	#Mid	21.16	20.96	20.90	20.83	--	--
		1	#Max	20.82	20.68	20.44	20.71	--	--
		50%	#0	20.65	19.62	19.98	19.97	--	--
		50%	#Mid	20.23	19.59	19.95	19.95	--	--
		50%	#Max	20.76	19.71	19.96	19.95	--	--
		100%	--	19.65	19.83	19.97	19.70	--	--
High	QPSK	1	#0	22.50	22.50	22.50	22.51	--	--
		1	#Mid	22.59	22.84	22.89	23.04	--	--
		1	#Max	22.58	22.51	22.56	22.60	--	--
		50%	#0	21.62	21.71	21.80	21.80	--	--
		50%	#Mid	21.69	21.86	21.86	21.87	--	--
		50%	#Max	21.76	21.78	21.75	21.78	--	--
		100%	--	21.81	21.77	21.72	21.81	--	--
	16QAM	1	#0	21.53	21.62	21.49	21.27	--	--
		1	#Mid	21.95	21.71	21.44	21.73	--	--
		1	#Max	21.67	21.66	21.49	21.47	--	--
		50%	#0	21.88	20.54	20.74	20.91	--	--
		50%	#Mid	21.93	20.66	20.66	20.82	--	--
		50%	#Max	21.86	20.50	20.85	21.00	--	--
		100%	--	20.56	20.76	20.68	20.84	--	--
	64QAM	1	#0	21.27	20.67	20.50	20.70	--	--
		1	#Mid	21.24	21.10	20.78	21.38	--	--
		1	#Max	21.23	20.76	20.16	21.22	--	--
		50%	#0	20.85	19.60	19.62	19.94	--	--
		50%	#Mid	20.90	19.66	19.72	19.69	--	--
		50%	#Max	20.81	19.60	19.67	19.99	--	--
		100%	--	19.76	19.71	19.81	19.77	--	--

Channel	Modulation	LTE Band 13							
		RB	RB	Maximum Conducted Output Power					
		No.	Offset	1.4M	3M	5M	10M	15M	20M
Low	QPSK	1	#0	--	--	22.50	--	--	--
		1	#Mid	--	--	22.55	--	--	--
		1	#Max	--	--	22.50	--	--	--
		50%	#0	--	--	21.70	--	--	--
		50%	#Mid	--	--	21.74	--	--	--
		50%	#Max	--	--	21.70	--	--	--
		100%	--	--	--	21.72	--	--	--
	16QAM	1	#0	--	--	21.32	--	--	--
		1	#Mid	--	--	21.50	--	--	--
		1	#Max	--	--	21.42	--	--	--
		50%	#0	--	--	20.24	--	--	--
		50%	#Mid	--	--	20.30	--	--	--
		50%	#Max	--	--	20.29	--	--	--
		100%	--	--	--	20.37	--	--	--
	64QAM	1	#0	--	--	20.57	--	--	--
		1	#Mid	--	--	20.88	--	--	--
		1	#Max	--	--	20.33	--	--	--
		50%	#0	--	--	19.41	--	--	--
		50%	#Mid	--	--	19.49	--	--	--
		50%	#Max	--	--	19.46	--	--	--
		100%	--	--	--	19.58	--	--	--
Mid	QPSK	1	#0	--	--	22.51	22.53	--	--
		1	#Mid	--	--	22.59	22.72	--	--
		1	#Max	--	--	22.53	22.60	--	--
		50%	#0	--	--	21.71	21.78	--	--
		50%	#Mid	--	--	21.75	21.82	--	--
		50%	#Max	--	--	21.63	21.76	--	--
		100%	--	--	--	21.69	21.77	--	--
	16QAM	1	#0	--	--	21.52	21.74	--	--
		1	#Mid	--	--	21.94	22.04	--	--
		1	#Max	--	--	21.43	21.69	--	--
		50%	#0	--	--	20.60	20.85	--	--
		50%	#Mid	--	--	20.59	20.88	--	--
		50%	#Max	--	--	20.66	20.72	--	--

		100%	--	--	--	20.87	20.68	--	--
	64QAM	1	#0	--	--	20.30	20.80	--	--
		1	#Mid	--	--	20.84	21.27	--	--
		1	#Max	--	--	20.15	20.96	--	--
		50%	#0	--	--	19.81	19.45	--	--
		50%	#Mid	--	--	19.76	19.82	--	--
		50%	#Max	--	--	19.74	19.59	--	--
		100%	--	--	--	19.89	19.76	--	--
High	QPSK	1	#0	--	--	22.54	--	--	--
		1	#Mid	--	--	22.58	--	--	--
		1	#Max	--	--	22.52	--	--	--
		50%	#0	--	--	21.65	--	--	--
		50%	#Mid	--	--	21.58	--	--	--
		50%	#Max	--	--	21.73	--	--	--
		100%	--	--	--	21.72	--	--	--
	16QAM	1	#0	--	--	21.52	--	--	--
		1	#Mid	--	--	21.87	--	--	--
		1	#Max	--	--	21.44	--	--	--
		50%	#0	--	--	20.68	--	--	--
		50%	#Mid	--	--	20.63	--	--	--
		50%	#Max	--	--	20.58	--	--	--
		100%	--	--	--	20.60	--	--	--
	64QAM	1	#0	--	--	20.47	--	--	--
		1	#Mid	--	--	20.90	--	--	--
		1	#Max	--	--	20.38	--	--	--
		50%	#0	--	--	19.70	--	--	--
		50%	#Mid	--	--	19.90	--	--	--
		50%	#Max	--	--	19.68	--	--	--
		100%	--	--	--	19.36	--	--	--

Channel	Modulation	LTE Band 17							
		RB	RB	Maximum Conducted Output Power					
		No.	Offset	1.4M	3M	5M	10M	15M	20M
Low	QPSK	1	#0	--	--	22.50	22.51	--	--
		1	#Mid	--	--	22.53	22.65	--	--
		1	#Max	--	--	22.52	22.50	--	--
		50%	#0	--	--	21.57	21.59	--	--
		50%	#Mid	--	--	21.53	21.66	--	--
		50%	#Max	--	--	21.55	21.62	--	--
		100%	--	--	--	21.51	21.58	--	--
	16QAM	1	#0	--	--	21.34	21.36	--	--
		1	#Mid	--	--	21.38	21.49	--	--
		1	#Max	--	--	21.18	21.32	--	--
		50%	#0	--	--	20.45	20.59	--	--
		50%	#Mid	--	--	20.56	20.60	--	--
		50%	#Max	--	--	20.51	20.45	--	--
		100%	--	--	--	20.53	20.54	--	--
	64QAM	1	#0	--	--	20.38	20.77	--	--
		1	#Mid	--	--	20.92	21.11	--	--
		1	#Max	--	--	20.29	20.58	--	--
		50%	#0	--	--	19.60	19.71	--	--
		50%	#Mid	--	--	19.60	19.78	--	--
		50%	#Max	--	--	19.57	19.77	--	--
		100%	--	--	--	19.73	19.57	--	--
Mid	QPSK	1	#0	--	--	22.51	22.54	--	--
		1	#Mid	--	--	22.74	22.83	--	--
		1	#Max	--	--	22.51	22.51	--	--
		50%	#0	--	--	21.57	21.70	--	--
		50%	#Mid	--	--	21.67	21.71	--	--
		50%	#Max	--	--	21.55	21.65	--	--
		100%	--	--	--	21.52	21.62	--	--
	16QAM	1	#0	--	--	21.25	21.42	--	--
		1	#Mid	--	--	21.48	21.85	--	--
		1	#Max	--	--	21.47	21.40	--	--
		50%	#0	--	--	20.47	20.47	--	--
		50%	#Mid	--	--	20.50	20.47	--	--
		50%	#Max	--	--	20.47	20.40	--	--
		50%	#Max	--	--	20.47	20.40	--	--

		100%	--	--	--	20.49	20.54	--	--
	64QAM	1	#0	--	--	20.57	20.63	--	--
		1	#Mid	--	--	21.03	21.09	--	--
		1	#Max	--	--	20.50	20.46	--	--
		50%	#0	--	--	19.60	19.71	--	--
		50%	#Mid	--	--	19.63	19.78	--	--
		50%	#Max	--	--	19.60	19.75	--	--
		100%	--	--	--	19.34	19.56	--	--
High	QPSK	1	#0	--	--	22.51	22.54	--	--
		1	#Mid	--	--	22.61	22.64	--	--
		1	#Max	--	--	22.52	22.52	--	--
		50%	#0	--	--	21.51	21.50	--	--
		50%	#Mid	--	--	21.51	21.57	--	--
		50%	#Max	--	--	21.50	21.56	--	--
		100%	--	--	--	21.53	21.58	--	--
	16QAM	1	#0	--	--	21.33	21.61	--	--
		1	#Mid	--	--	21.56	21.89	--	--
		1	#Max	--	--	21.41	21.51	--	--
		50%	#0	--	--	20.35	20.67	--	--
		50%	#Mid	--	--	20.51	20.73	--	--
		50%	#Max	--	--	20.35	20.44	--	--
		100%	--	--	--	20.49	20.46	--	--
	64QAM	1	#0	--	--	20.41	20.16	--	--
		1	#Mid	--	--	21.04	20.72	--	--
		1	#Max	--	--	20.43	20.11	--	--
		50%	#0	--	--	19.61	19.74	--	--
		50%	#Mid	--	--	19.69	19.73	--	--
		50%	#Max	--	--	19.67	19.78	--	--
		100%	--	--	--	19.24	19.77	--	--

Channel	Modulation	LTE Band 25							
		RB	RB	Maximum Conducted Output Power					
		No.	Offset	1.4M	3M	5M	10M	15M	20M
Low	QPSK	1	#0	22.04	22.07	21.85	21.95	22.20	22.23
		1	#Mid	22.24	22.21	21.94	21.96	22.27	22.36
		1	#Max	22.17	21.99	21.78	21.78	21.99	22.01
		50%	#0	21.21	21.34	21.21	21.16	21.09	21.35
		50%	#Mid	21.18	21.35	21.12	21.18	21.10	21.38
		50%	#Max	21.13	21.19	21.14	21.16	21.19	21.25
		100%	--	21.32	21.17	21.13	21.16	21.23	21.34
	16QAM	1	#0	21.49	20.92	21.01	21.08	21.03	20.85
		1	#Mid	21.50	20.96	20.82	21.10	20.90	21.15
		1	#Max	21.42	21.08	20.88	20.92	20.96	20.91
		50%	#0	21.33	20.20	20.12	20.23	20.15	20.09
		50%	#Mid	21.40	20.30	20.11	20.18	20.11	20.14
		50%	#Max	21.35	20.35	20.11	20.23	20.17	20.21
		100%	--	20.31	20.17	20.32	20.23	20.29	20.15
	64QAM	1	#0	20.32	20.12	20.12	20.18	20.26	20.26
		1	#Mid	20.30	20.53	20.42	20.21	20.54	20.31
		1	#Max	20.20	20.05	19.88	20.09	20.20	20.19
		50%	#0	20.23	19.23	19.36	19.26	19.19	19.20
		50%	#Mid	20.31	19.23	19.18	19.27	19.21	19.15
		50%	#Max	20.26	19.07	19.20	19.25	19.10	19.22
		100%	--	19.20	19.17	19.24	19.07	19.01	19.16
Mid	QPSK	1	#0	22.38	22.26	22.22	22.13	22.14	22.44
		1	#Mid	22.44	22.43	22.56	22.42	22.44	22.73
		1	#Max	22.12	22.32	22.28	22.41	22.16	22.45
		50%	#0	21.41	21.49	21.42	21.43	21.40	21.50
		50%	#Mid	21.33	21.46	21.48	21.44	21.42	21.55
		50%	#Max	21.39	21.45	21.45	21.43	21.38	21.51
		100%	--	21.44	21.37	21.39	21.42	21.43	21.46
	16QAM	1	#0	21.39	21.17	21.19	21.14	21.08	20.95
		1	#Mid	21.55	21.22	21.16	21.40	21.02	21.37
		1	#Max	21.28	21.27	21.15	21.14	20.95	20.97
		50%	#0	21.51	20.33	20.36	20.50	20.38	20.36
		50%	#Mid	21.52	20.39	20.35	20.31	20.30	20.37
		50%	#Max	21.42	20.40	20.31	20.29	20.33	20.34

	64QAM	100%	--	20.36	20.36	20.26	20.40	20.39	20.38
		1	#0	20.66	20.32	20.22	20.27	20.30	20.10
		1	#Mid	20.65	20.72	20.77	20.84	20.33	20.85
		1	#Max	20.42	20.27	20.17	20.38	20.25	20.51
		50%	#0	20.40	19.33	19.54	19.31	19.40	19.30
		50%	#Mid	20.39	19.40	19.51	19.61	19.52	19.49
		50%	#Max	20.35	19.44	19.48	19.20	19.47	19.44
		100%	--	19.32	19.41	19.28	19.31	19.39	19.48
High	QPSK	1	#0	21.55	22.40	22.10	22.21	22.31	22.43
		1	#Mid	21.70	22.65	22.51	22.62	22.47	22.69
		1	#Max	21.03	21.02	21.03	21.01	21.04	21.07
		50%	#0	21.41	21.35	21.33	21.39	21.30	21.49
		50%	#Mid	21.17	21.46	21.46	21.47	21.44	21.54
		50%	#Max	20.96	21.47	21.43	21.45	21.41	21.48
		100%	--	21.23	21.32	21.34	21.43	21.45	21.45
		16QAM	1	#0	21.02	21.51	21.37	21.33	21.19
	1		#Mid	21.12	21.44	21.37	21.58	21.18	21.42
	1		#Max	20.24	21.54	20.34	20.33	20.20	20.53
	50%		#0	20.88	20.74	20.66	20.39	20.39	20.37
	50%		#Mid	20.64	20.70	20.61	20.50	20.46	20.45
	50%		#Max	20.45	20.73	20.42	20.50	20.58	20.52
	100%		--	20.64	20.78	20.65	20.56	20.48	20.33
	64QAM		1	#0	20.32	20.69	20.42	20.44	20.44
		1	#Mid	20.19	20.72	20.94	21.01	20.70	20.79
		1	#Max	19.76	19.63	19.49	19.44	19.28	19.50
		50%	#0	20.21	19.71	20.02	19.68	19.64	19.34
		50%	#Mid	20.02	19.50	19.74	19.85	19.63	19.49
		50%	#Max	19.88	19.45	19.40	19.57	19.77	19.65
		100%	--	19.56	19.73	19.37	19.63	19.42	19.56

Channel	Modulation	LTE Band 26							
		RB	RB	Maximum Conducted Output Power					
		No.	Offset	1.4M	3M	5M	10M	15M	20M
Low	QPSK	1	#0	22.35	23.48	22.56	22.55	22.63	22.35
		1	#Mid	22.38	23.63	23.64	23.34	23.79	22.38
		1	#Max	22.34	22.58	22.54	22.55	22.59	22.34
		50%	#0	22.37	22.30	22.31	22.34	22.56	22.37
		50%	#Mid	22.33	22.45	22.40	22.39	22.58	22.33
		50%	#Max	22.30	22.37	22.28	22.26	22.54	22.30
		100%	--	21.29	22.30	22.39	22.25	22.45	21.29
	16QAM	1	#0	22.25	22.77	22.25	22.26	21.68	22.25
		1	#Mid	22.29	23.14	23.05	22.66	22.51	22.29
		1	#Max	22.29	22.82	21.79	21.87	21.53	22.29
		50%	#0	22.09	21.66	21.37	21.39	21.13	22.09
		50%	#Mid	22.16	21.71	21.67	21.45	21.29	22.16
		50%	#Max	22.10	21.65	21.33	21.31	21.22	22.10
		100%	--	21.01	21.55	21.44	21.29	21.13	21.01
	64QAM	1	#0	21.96	21.75	21.27	21.17	20.69	21.96
		1	#Mid	22.06	22.13	22.06	21.58	21.53	22.06
		1	#Max	22.00	21.82	20.84	20.78	20.50	22.00
		50%	#0	21.93	20.69	20.45	20.42	20.19	21.93
		50%	#Mid	22.00	20.73	20.74	20.48	20.34	22.00
		50%	#Max	21.96	20.65	20.42	20.34	20.26	21.96
		100%	--	20.69	20.61	20.47	20.32	20.15	20.69
Mid	QPSK	1	#0	22.01	22.43	22.63	22.59	23.05	22.01
		1	#Mid	22.45	23.37	23.34	23.68	23.91	22.45
		1	#Max	22.22	22.35	22.74	22.68	23.28	22.22
		50%	#0	22.00	22.26	22.14	22.21	22.65	22.00
		50%	#Mid	20.52	22.51	22.50	22.41	22.68	20.52
		50%	#Max	21.90	22.09	22.19	22.16	22.61	21.90
		100%	--	21.37	22.38	22.16	22.09	22.49	21.37
	16QAM	1	#0	22.30	22.34	21.88	21.87	21.45	22.30
		1	#Mid	22.42	22.70	22.65	22.97	22.64	22.42
		1	#Max	22.37	22.59	22.07	22.01	21.40	22.37
		50%	#0	22.10	21.47	21.21	21.26	21.18	22.10
		50%	#Mid	22.40	21.62	21.56	21.45	21.41	22.40
		50%	#Max	22.37	21.50	21.26	21.20	21.03	22.37

	64QAM	100%	--	21.51	21.48	21.21	21.13	21.11	21.51
		1	#0	21.61	21.32	20.92	20.85	20.60	21.61
		1	#Mid	21.86	21.69	21.64	21.99	21.66	21.86
		1	#Max	21.82	21.59	21.04	20.94	20.40	21.82
		50%	#0	21.55	20.48	20.26	20.29	20.22	21.55
		50%	#Mid	21.85	20.64	20.64	20.50	20.46	21.85
		50%	#Max	21.83	20.52	20.32	20.26	20.08	21.83
100%	--	20.46	20.54	20.24	20.16	20.13	20.46		
High	QPSK	1	#0	22.33	22.72	22.59	22.68	22.77	22.33
		1	#Mid	22.48	22.74	22.88	23.41	23.45	22.48
		1	#Max	22.17	22.08	22.05	22.05	22.24	22.17
		50%	#0	21.42	21.56	21.90	22.11	22.13	21.42
		50%	#Mid	21.41	21.44	21.81	22.20	22.21	21.41
		50%	#Max	21.33	21.25	21.22	21.67	21.74	21.33
		100%	--	21.25	21.40	21.57	21.82	21.87	21.25
	16QAM	1	#0	21.64	21.99	21.84	21.96	21.60	21.64
		1	#Mid	21.70	22.00	22.23	22.73	22.46	21.70
		1	#Max	21.51	21.41	20.93	20.94	20.47	21.51
		50%	#0	21.51	20.67	20.97	21.14	21.07	21.51
		50%	#Mid	21.54	20.55	20.88	21.24	21.22	21.54
		50%	#Max	21.45	20.36	20.29	20.71	20.89	21.45
		100%	--	20.38	20.47	20.63	20.87	20.91	20.38
	64QAM	1	#0	20.75	21.03	20.90	20.96	20.61	20.75
		1	#Mid	20.79	21.05	21.24	21.73	21.47	20.79
		1	#Max	20.65	20.45	19.95	19.94	19.46	20.65
		50%	#0	20.65	19.72	20.04	20.18	20.12	20.65
		50%	#Mid	20.67	19.59	19.98	20.29	20.28	20.67
		50%	#Max	20.59	19.37	19.38	19.76	19.94	20.59
		100%	--	19.34	19.52	19.67	19.91	20.81	19.34

Channel	Modulation	LTE Band 38							
		RB	RB	Maximum Conducted Output Power					
		No.	Offset	1.4M	3M	5M	10M	15M	20M
Low	QPSK	1	#0	--	--	21.02	21.15	21.25	21.36
		1	#Mid	--	--	21.31	21.15	21.11	21.32
		1	#Max	--	--	21.15	21.20	21.21	21.22
		50%	#0	--	--	20.24	20.30	20.26	20.33
		50%	#Mid	--	--	20.27	20.30	20.24	20.37
		50%	#Max	--	--	20.25	20.31	20.31	20.32
		100%	--	--	--	20.31	20.33	20.30	20.34
	16QAM	1	#0	--	--	19.66	19.84	19.91	19.75
		1	#Mid	--	--	19.89	19.89	19.58	19.90
		1	#Max	--	--	19.65	19.87	19.89	19.75
		50%	#0	--	--	19.12	19.16	19.36	19.15
		50%	#Mid	--	--	19.48	19.23	19.34	19.29
		50%	#Max	--	--	19.45	19.17	19.16	19.19
		100%	--	--	--	19.16	19.35	19.28	19.24
	64QAM	1	#0	--	--	18.71	18.89	18.87	18.68
		1	#Mid	--	--	19.40	18.93	18.72	18.88
		1	#Max	--	--	18.70	18.90	18.83	18.86
		50%	#0	--	--	18.22	18.27	18.44	18.26
		50%	#Mid	--	--	18.24	18.58	18.45	18.23
		50%	#Max	--	--	18.23	18.35	18.36	18.23
		100%	--	--	--	18.24	18.35	18.34	18.36
Mid	QPSK	1	#0	--	--	21.06	21.33	21.25	21.41
		1	#Mid	--	--	21.33	21.19	21.15	21.33
		1	#Max	--	--	21.01	21.34	21.11	21.35
		50%	#0	--	--	20.18	20.32	20.26	20.25
		50%	#Mid	--	--	20.20	20.34	20.22	20.27
		50%	#Max	--	--	20.24	20.32	20.28	20.23
		100%	--	--	--	20.26	20.26	20.20	20.26
	16QAM	1	#0	--	--	19.58	19.95	19.92	19.64
		1	#Mid	--	--	19.91	20.06	19.68	19.95
		1	#Max	--	--	19.58	19.75	19.66	19.69
		50%	#0	--	--	19.06	19.17	19.23	19.12
		50%	#Mid	--	--	19.39	19.59	19.32	19.30
		50%	#Max	--	--	19.09	19.22	19.15	19.13

	64QAM	100%	--	--	--	19.12	19.31	19.23	19.19
		1	#0	--	--	18.84	18.99	18.85	18.76
		1	#Mid	--	--	19.44	19.06	18.74	18.86
		1	#Max	--	--	18.75	18.89	18.81	18.75
		50%	#0	--	--	18.14	18.62	18.23	18.23
		50%	#Mid	--	--	18.17	18.32	18.21	18.19
		50%	#Max	--	--	18.10	18.63	18.19	18.21
100%	--	--	--	18.23	18.26	18.31	18.39		
High	QPSK	1	#0	--	--	21.01	21.01	21.14	21.15
		1	#Mid	--	--	21.07	21.02	21.05	21.09
		1	#Max	--	--	21.05	21.10	21.10	21.11
		50%	#0	--	--	20.02	20.18	20.22	20.24
		50%	#Mid	--	--	20.19	20.18	20.19	20.20
		50%	#Max	--	--	20.13	20.13	20.19	20.21
		100%	--	--	--	20.17	20.10	20.12	20.20
	16QAM	1	#0	--	--	19.40	19.68	19.75	19.61
		1	#Mid	--	--	19.67	19.69	19.64	19.73
		1	#Max	--	--	19.66	19.60	19.53	19.61
		50%	#0	--	--	19.15	19.06	19.01	19.07
		50%	#Mid	--	--	19.32	19.07	19.06	19.10
		50%	#Max	--	--	19.29	19.08	19.07	19.24
		100%	--	--	--	19.19	19.26	19.19	19.18
	64QAM	1	#0	--	--	18.59	18.72	18.81	18.68
		1	#Mid	--	--	19.26	18.84	18.69	18.78
		1	#Max	--	--	18.64	18.81	18.76	18.68
		50%	#0	--	--	17.92	18.21	18.25	18.15
		50%	#Mid	--	--	18.11	18.23	18.23	18.22
		50%	#Max	--	--	18.06	18.17	18.26	18.18
		100%	--	--	--	18.13	18.25	18.16	18.32

Channel	Modulation	LTE Band 41							
		RB	RB	Maximum Conducted Output Power					
		No.	Offset	1.4M	3M	5M	10M	15M	20M
Low	QPSK	1	#0	--	--	22.22	22.19	22.22	22.27
		1	#Mid	--	--	22.25	22.23	22.12	22.34
		1	#Max	--	--	21.88	22.14	22.09	22.21
		50%	#0	--	--	21.15	21.15	21.15	21.45
		50%	#Mid	--	--	21.20	21.11	21.13	21.45
		50%	#Max	--	--	21.10	21.14	21.11	21.39
		100%	--	--	--	21.08	21.16	21.10	21.41
	16QAM	1	#0	--	--	20.65	20.72	20.70	20.65
		1	#Mid	--	--	20.66	20.86	20.75	20.87
		1	#Max	--	--	20.61	20.59	20.55	20.45
		50%	#0	--	--	20.35	20.48	20.02	20.18
		50%	#Mid	--	--	20.39	20.47	20.02	20.25
		50%	#Max	--	--	20.32	20.45	20.09	20.32
		100%	--	--	--	20.50	20.11	20.20	20.24
	64QAM	1	#0	--	--	20.27	20.20	20.39	20.24
		1	#Mid	--	--	20.42	20.30	20.26	20.32
		1	#Max	--	--	19.94	20.20	20.22	20.17
		50%	#0	--	--	20.37	20.20	20.05	20.13
		50%	#Mid	--	--	20.34	20.18	20.17	20.19
		50%	#Max	--	--	20.30	20.27	20.16	20.15
		100%	--	--	--	20.40	20.23	20.18	20.20
Mid	QPSK	1	#0	--	--	21.76	21.92	21.99	22.30
		1	#Mid	--	--	22.01	22.04	21.96	22.60
		1	#Max	--	--	21.83	22.01	21.91	22.25
		50%	#0	--	--	20.99	21.08	21.01	21.46
		50%	#Mid	--	--	21.06	21.07	21.06	21.54
		50%	#Max	--	--	21.01	21.04	21.05	21.53
		100%	--	--	--	20.99	21.06	21.05	21.53
	16QAM	1	#0	--	--	20.34	20.52	20.30	20.48
		1	#Mid	--	--	20.63	20.77	20.51	20.76
		1	#Max	--	--	20.54	20.58	20.49	20.42
		50%	#0	--	--	20.19	20.40	20.08	19.90
		50%	#Mid	--	--	20.31	20.37	20.19	20.18
		50%	#Max	--	--	20.23	20.36	20.22	20.14

	64QAM	100%	--	--	--	20.19	20.02	20.11	20.06
		1	#0	--	--	19.82	20.05	20.35	19.75
		1	#Mid	--	--	20.30	20.18	20.20	20.11
		1	#Max	--	--	20.06	20.01	20.23	20.08
		50%	#0	--	--	20.23	20.10	20.24	20.05
		50%	#Mid	--	--	20.25	20.13	20.31	20.10
		50%	#Max	--	--	20.24	20.16	20.33	20.05
		100%	--	--	--	20.12	20.16	20.09	20.10
High	QPSK	1	#0	--	--	21.41	21.54	21.64	21.75
		1	#Mid	--	--	21.51	21.66	21.63	22.07
		1	#Max	--	--	21.37	21.61	21.64	21.83
		50%	#0	--	--	20.62	20.74	20.73	20.94
		50%	#Mid	--	--	20.70	20.73	20.73	20.95
		50%	#Max	--	--	20.65	20.73	20.71	21.02
		100%	--	--	--	20.63	20.71	20.70	20.96
	16QAM	1	#0	--	--	20.10	20.18	20.18	20.10
		1	#Mid	--	--	20.12	20.44	20.29	20.31
		1	#Max	--	--	20.11	20.27	20.22	20.13
		50%	#0	--	--	19.82	20.06	19.63	19.61
		50%	#Mid	--	--	19.81	19.86	19.80	19.83
		50%	#Max	--	--	19.86	20.06	19.87	19.81
		100%	--	--	--	20.00	19.65	19.73	19.75
	64QAM	1	#0	--	--	19.75	19.74	19.95	19.56
		1	#Mid	--	--	19.96	19.81	19.60	19.88
		1	#Max	--	--	19.60	19.57	19.89	19.84
		50%	#0	--	--	19.57	19.79	19.93	19.76
		50%	#Mid	--	--	19.67	19.79	19.91	19.76
		50%	#Max	--	--	19.82	19.78	19.69	19.73
		100%	--	--	--	19.77	19.77	19.72	19.79

Channel	Modulation	LTE Band 66							
		RB	RB	Maximum Conducted Output Power					
		No.	Offset	1.4M	3M	5M	10M	15M	20M
Low	QPSK	1	#0	17.50	17.29	17.41	17.48	17.54	17.59
		1	#Mid	17.60	17.54	17.60	17.61	17.59	17.94
		1	#Max	17.52	17.27	17.44	17.29	17.45	17.54
		50%	#0	16.67	16.54	16.70	16.65	16.55	16.77
		50%	#Mid	16.53	16.51	16.69	16.63	16.57	16.73
		50%	#Max	16.62	16.55	16.57	16.63	16.47	16.68
		100%	--	16.62	16.64	16.47	16.61	16.53	16.72
	16QAM	1	#0	16.48	16.62	16.42	16.46	16.41	16.73
		1	#Mid	16.50	16.65	16.50	16.64	16.62	16.74
		1	#Max	16.45	16.57	16.41	16.45	16.34	16.60
		50%	#0	15.78	15.44	15.47	15.77	15.46	15.89
		50%	#Mid	15.75	15.35	15.43	15.75	15.44	15.83
		50%	#Max	15.68	15.31	15.51	15.60	15.47	15.71
		100%	--	15.55	15.47	15.65	15.46	15.44	15.74
	64QAM	1	#0	16.63	16.52	16.46	16.59	16.41	16.82
		1	#Mid	16.66	16.54	16.54	16.62	16.49	16.86
		1	#Max	16.49	16.42	16.53	16.40	16.42	16.61
		50%	#0	15.64	15.47	15.40	15.71	15.62	15.84
		50%	#Mid	15.63	15.57	15.49	15.70	15.54	15.73
		50%	#Max	15.61	15.46	15.40	15.63	15.46	15.72
		100%	--	15.39	15.51	15.66	15.66	15.52	15.73
Mid	QPSK	1	#0	17.74	17.80	17.80	17.76	17.75	17.93
		1	#Mid	17.85	17.89	17.86	17.84	17.81	18.01
		1	#Max	17.76	17.78	17.76	17.68	17.70	17.87
		50%	#0	16.60	16.86	16.69	16.72	16.59	16.89
		50%	#Mid	16.65	16.75	16.72	16.77	16.62	16.79
		50%	#Max	16.74	16.80	16.67	16.69	16.52	16.81
		100%	--	16.76	16.67	16.69	16.68	16.50	16.80
	16QAM	1	#0	16.82	16.85	16.81	16.80	16.70	16.94
		1	#Mid	16.86	16.99	16.95	16.87	16.88	17.02
		1	#Max	16.81	16.86	16.82	16.79	16.68	16.86
		50%	#0	15.75	15.67	15.70	15.60	15.53	15.87
		50%	#Mid	15.70	15.73	15.75	15.64	15.54	15.85
		50%	#Max	15.62	15.77	15.63	15.59	15.55	15.88

		100%	--	15.61	15.45	15.62	15.63	15.53	15.67
	64QAM	1	#0	16.46	16.42	16.83	16.88	16.76	16.93
		1	#Mid	16.58	16.57	16.90	16.90	16.85	16.99
		1	#Max	16.40	16.44	16.79	16.81	16.74	16.89
		50%	#0	15.70	15.60	15.57	15.71	15.72	15.73
		50%	#Mid	15.77	15.53	15.48	15.71	15.71	15.78
		50%	#Max	15.64	15.54	15.51	15.68	15.65	15.74
		100%	--	15.51	15.71	15.69	15.71	15.63	15.75
High	QPSK	1	#0	17.66	17.79	17.57	17.61	17.67	17.83
		1	#Mid	17.84	17.82	17.63	17.67	17.75	17.96
		1	#Max	17.64	17.74	17.54	17.54	17.43	17.86
		50%	#0	16.69	16.73	16.69	16.69	16.64	16.87
		50%	#Mid	16.67	16.68	16.67	16.68	16.57	16.78
		50%	#Max	16.70	16.68	16.64	16.62	16.54	16.73
		100%	--	16.73	16.73	16.62	16.64	16.57	16.78
	16QAM	1	#0	16.60	16.63	16.41	16.63	16.58	16.68
		1	#Mid	16.64	16.66	16.42	16.65	16.69	16.96
		1	#Max	16.49	16.48	16.40	16.54	16.66	16.73
		50%	#0	15.86	15.48	15.41	15.59	15.65	15.89
		50%	#Mid	15.70	15.49	15.47	15.60	15.61	15.76
		50%	#Max	15.63	15.47	15.48	15.50	15.50	15.70
		100%	--	15.56	15.70	15.53	15.66	15.59	15.77
	64QAM	1	#0	16.40	16.52	16.40	16.38	16.49	16.62
		1	#Mid	16.58	16.60	16.55	16.52	16.69	16.76
		1	#Max	16.48	16.50	16.49	16.43	16.48	16.71
		50%	#0	15.72	15.64	15.50	15.78	15.58	15.91
		50%	#Mid	15.70	15.62	15.49	15.77	15.62	15.88
		50%	#Max	15.69	15.60	15.51	15.70	15.71	15.83
		100%	--	15.62	15.63	15.68	15.74	15.64	15.90

9. Test Results

9.1 SAR Test Results Summary

WLAN 2.4G Head SAR								
SAR MEASUREMENT								
Liquid Temperature (°C) : 21.9 ±2					Relative Humidity (%) : 51%			
Ambient Temperature (°C) : 22.7 ±2					Depth of Liquid (cm) : >15			
Test Position	Dist (mm)	Frequency		Conducted Power (dBm)		SAR 1g (W/kg)		Plot No.
		Channel	MHz	Measurement	Tune-up Limit	Measurement	Tune-up Scaled	
Test Mode : 802.11b_Main								
Left-Cheek	0	1	2412	17.88	18	0.810	0.833	1
Left-Cheek	0	6	2437	17.92	18	0.669	0.681	
Left-Cheek	0	11	2462	17.85	18	0.731	0.757	
Left-Tilt	0	6	2437	17.92	18	0.490	0.499	
Right-Cheek	0	6	2437	17.92	18	0.342	0.348	
Right-Tilt	0	6	2437	17.92	18	0.240	0.244	
Test Mode : BT-1M_Main								
Left-Cheek	0	0	2402	7.51	8	0.046	0.052	2
Left-Tilt	0	0	2402	7.51	8	0.024	0.027	
Right-Cheek	0	0	2402	7.51	8	0.030	0.033	
Right-Tilt	0	0	2402	7.51	8	0.011	0.012	
Note: 1. When the highest reported SAR for DSSS is adjusted by the ratio of OFDM to DSSS specified maximum output power and the adjusted SAR is ≤ 1.2 W/kg, SAR is not required. 2. When the reported SAR of the highest measured maximum output power channel for the exposure configuration is ≤ 0.8 W/kg, no further SAR testing is required for 802.11b DSSS in that exposure configuration.								

WLAN 2.4G Body SAR								
SAR MEASUREMENT								
Liquid Temperature (°C) : 21.9 ±2					Relative Humidity (%) : 51%			
Ambient Temperature (°C) : 22.7 ±2					Depth of Liquid (cm) : >15			
Test Position	Dist (mm)	Frequency		Conducted Power (dBm)		SAR 1g (W/kg)		Plot No.
		Channel	MHz	Measurement	Tune-up Limit	Measurement	Tune-up Scaled	
Test Mode : 802.11b_Main_10mm								
Front	10	6	2437	17.92	18	0.102	0.104	
Back	10	1	2412	17.88	18	0.188	0.193	
Back	10	6	2437	17.92	18	0.171	0.174	
Back	10	11	2462	17.85	18	0.204	0.211	3
Right-side	10	6	2437	17.92	18	0.120	0.122	
Top	10	6	2437	17.92	18	0.114	0.116	
Test Mode : BT-1M_Main_10mm								
Front	10	0	2402	7.51	8	0.011	0.012	
Back	10	0	2402	7.51	8	0.013	0.015	4
Right-side	10	0	2402	7.51	8	0.00699	0.008	
Top	10	0	2402	7.51	8	0.00616	0.007	
Note: 1. When the highest reported SAR for DSSS is adjusted by the ratio of OFDM to DSSS specified maximum output power and the adjusted SAR is ≤ 1.2 W/kg, SAR is not required. 2. When the reported SAR of the highest measured maximum output power channel for the exposure configuration is ≤ 0.8 W/kg, no further SAR testing is required for 802.11b DSSS in that exposure configuration.								

WLAN 2.4G Product Specific 10g(Extremity)SAR								
SAR MEASUREMENT								
Liquid Temperature (°C) : 21.9 ±2					Relative Humidity (%) : 51%			
Ambient Temperature (°C) : 22.7 ±2					Depth of Liquid (cm) : >15			
Test Position	Dist (mm)	Frequency		Conducted Power (dBm)		SAR 10g (W/kg)		Plot No.
		Channel	MHz	Measurement	Tune-up Limit	Measurement	Tune-up Scaled	
Test Mode : 802.11b_Main_0mm								
Front	0	6	2437	17.92	18	0.501	0.510	
Back	0	1	2412	17.88	18	0.508	0.522	
Back	0	6	2437	17.92	18	0.525	0.535	5
Back	0	11	2462	17.85	18	0.515	0.533	
Right-side	0	6	2437	17.92	18	0.288	0.293	
Top	0	6	2437	17.92	18	0.242	0.246	
Test Mode : BT-1M_Main_0mm								
Front	0	0	2402	7.51	8	0.048	0.054	
Back	0	0	2402	7.51	8	0.051	0.057	6
Right-side	0	0	2402	7.51	8	0.028	0.031	
Top	0	0	2402	7.51	8	0.018	0.020	
Note: 1. When the highest reported SAR for DSSS is adjusted by the ratio of OFDM to DSSS specified maximum output power and the adjusted SAR is ≤ 1.2 W/kg, SAR is not required. 2. When the reported SAR of the highest measured maximum output power channel for the exposure configuration is ≤ 0.8 W/kg, no further SAR testing is required for 802.11b DSSS in that exposure configuration.								

WLAN 5G Head SAR								
SAR MEASUREMENT								
Liquid Temperature (°C) : 21.8 ±2					Relative Humidity (%) : 52%			
Ambient Temperature (°C) : 22.8 ±2					Depth of Liquid (cm) : >15			
Test Position	Dist (mm)	Frequency		Conducted Power (dBm)		SAR 1g (W/kg)		Plot No.
		Channel	MHz	Measurement	Tune-up Limit	Measurement	Tune-up Scaled	
Test Mode :802.11ac80M_Main								
Left-Cheek	0	42	5210	14.43	14.5	0.852	0.866	
Left-Cheek	0	58	5290	14.44	14.5	0.844	0.856	
Left-Cheek	0	106	5530	14.31	14.5	0.803	0.839	
Left-Cheek	0	122	5610	14.43	14.5	0.854	0.868	
Left-Cheek	0	138	5690	14.43	14.5	1.070	1.087	7
Left-Cheek	0	155	5775	14.38	14.5	0.962	0.989	
Left-Tilt	0	58	5290	14.44	14.5	0.784	0.795	
Left-Tilt	0	106	5530	14.31	14.5	0.815	0.851	
Left-Tilt	0	122	5610	14.43	14.5	0.798	0.811	
Left-Tilt	0	138	5690	14.43	14.5	0.961	0.977	
Left-Tilt	0	155	5775	14.38	14.5	0.937	0.963	
Right-Cheek	0	58	5290	14.44	14.5	0.635	0.644	
Right-Cheek	0	122	5610	14.43	14.5	0.732	0.744	
Right-Cheek	0	155	5775	14.38	14.5	0.706	0.726	
Right-Tilt	0	58	5290	14.44	14.5	0.755	0.766	
Right-Tilt	0	122	5610	14.43	14.5	0.745	0.757	
Right-Tilt	0	155	5775	14.38	14.5	0.846	0.870	
Note : 1. When multiple transmission modes have the same specified maximum output power, largest channel bandwidth, lowest order modulation and lowest data rate, the lowest order 802.11 mode is selected 2. When the reported SAR of the highest measured maximum output power channel for the exposure configuration is ≤ 0.8 W/kg, no further SAR testing is required in that exposure configuration. 3. When the reported SAR of the highest measured maximum U-NII-2A for the exposure configuration is ≤ 1.2 W/kg, SAR is not required for U-NII-1 band.								

WLAN 5G Body SAR								
SAR MEASUREMENT								
Liquid Temperature (°C) : 21.8 ±2					Relative Humidity (%) : 52%			
Ambient Temperature (°C) : 22.8 ±2					Depth of Liquid (cm) : >15			
Test Position	Dist (mm)	Frequency		Conducted Power (dBm)		SAR 1g (W/kg)		Plot No.
		Channel	MHz	Measurement	Tune-up Limit	Measurement	Tune-up Scaled	
Test Mode :802.11ac80M_Main_10mm								
Front	10	42	5210	14.43	14.5	0.165	0.168	
Front	10	58	5290	14.44	14.5	0.173	0.175	
Front	10	122	5610	14.43	14.5	0.233	0.237	
Front	10	155	5775	14.38	14.5	0.262	0.269	
Back	10	42	5210	14.43	14.5	0.151	0.153	
Back	10	58	5290	14.44	14.5	0.182	0.185	
Back	10	106	5530	14.31	14.5	0.257	0.268	
Back	10	122	5610	14.43	14.5	0.269	0.273	
Back	10	138	5690	14.43	14.5	0.333	0.338	8
Back	10	155	5775	14.38	14.5	0.322	0.331	
Right-side	10	42	5210	14.43	14.5	0.058	0.059	
Right-side	10	155	5775	14.38	14.5	0.105	0.108	
Top	10	42	5210	14.43	14.5	0.253	0.257	
Top	10	155	5775	14.38	14.5	0.265	0.272	
Note : 1. When multiple transmission modes have the same specified maximum output power, largest channel bandwidth, lowest order modulation and lowest data rate, the lowest order 802.11 mode is selected 2. When the reported SAR of the highest measured maximum output power channel for the exposure configuration is ≤ 0.8 W/kg, no further SAR testing is required in that exposure configuration. 3. When the reported SAR of the highest measured maximum U-NII-2A for the exposure configuration is ≤ 1.2 W/kg, SAR is not required for U-NII-1 band.								

WLAN 5G Product Specific 10g (Extremity) SAR								
SAR MEASUREMENT								
Liquid Temperature (°C) : 21.8 ±2					Relative Humidity (%) : 52%			
Ambient Temperature (°C) : 22.8 ±2					Depth of Liquid (cm) : >15			
Test Position	Dist (mm)	Frequency		Conducted Power (dBm)		SAR 10g (W/kg)		Plot No.
		Channel	MHz	Measurement	Tune-up Limit	Measurement	Tune-up Scaled	
Test Mode : 802.11ac80M_Main_0mm								
Front	0	58	5290	14.44	14.5	0.263	0.267	
Front	0	122	5610	14.43	14.5	0.299	0.304	
Front	0	155	5775	14.38	14.5	0.324	0.333	
Back	0	58	5290	14.44	14.5	0.294	0.298	
Back	0	122	5610	14.43	14.5	0.380	0.386	
Back	0	155	5775	14.38	14.5	0.389	0.400	
Right-side	0	58	5290	14.44	14.5	0.083	0.084	
Right-side	0	122	5610	14.43	14.5	0.100	0.102	
Right-side	0	155	5775	14.38	14.5	0.111	0.114	
Top	0	58	5290	14.44	14.5	0.539	0.546	
Top	0	106	5530	14.31	14.5	0.586	0.612	
Top	0	122	5610	14.43	14.5	0.671	0.682	9
Top	0	138	5690	14.43	14.5	0.643	0.653	
Top	0	155	5775	14.38	14.5	0.630	0.648	
Note : 1. When multiple transmission modes have the same specified maximum output power, largest channel bandwidth, lowest order modulation and lowest data rate, the lowest order 802.11 mode is selected 2. When the reported SAR of the highest measured maximum output power channel for the exposure configuration is ≤ 0.8 W/kg, no further SAR testing is required in that exposure configuration. 3. When the reported SAR of the highest measured maximum U-NII-2A for the exposure configuration is ≤ 1.2 W/kg, SAR is not required for U-NII-1 band.								

GSM850 Head SAR								
SAR MEASUREMENT								
Liquid Temperature (°C) : 22.2 ±2					Relative Humidity (%) : 51%			
Ambient Temperature (°C) : 23.1 ±2					Depth of Liquid (cm) : >15			
Test Position	Dist (mm)	Frequency		Conducted Power (dBm)		SAR 1g (W/kg)		Plot No.
		Channel	MHz	Measurement	Tune-up Limit	Measurement	Tune-up Scaled	
Test Mode : GSM850 GPRS 4UP								
Left-Cheek	0	189	836.4	29.61	30	0.618	0.676	
Left-Tilt	0	189	836.4	29.61	30	0.485	0.531	
Right-Cheek	0	128	824.2	29.59	30	0.819	0.900	10
Right-Cheek	0	189	836.4	29.61	30	0.669	0.732	
Right-Cheek	0	251	848.8	29.55	30	0.625	0.693	
Right-Tilt	0	189	836.4	29.61	30	0.513	0.561	
Note: 1. When the reported SAR of the Mid channel for the exposure configuration is ≤ 0.8 W/kg, no further SAR testing is required in other channel.								

GSM850 Body SAR								
SAR MEASUREMENT								
Liquid Temperature (°C) : 22.2 ±2					Relative Humidity (%) : 51%			
Ambient Temperature (°C) : 23.1 ±2					Depth of Liquid (cm) : >15			
Test Position	Dist (mm)	Frequency		Conducted Power (dBm)		SAR 1g (W/kg)		Plot No.
		Channel	MHz	Measurement	Tune-up Limit	Measurement	Tune-up Scaled	
Test Mode : GSM850 GPRS 4UP_10mm								
Front	10	128	824.2	29.59	30	0.836	0.919	11
Front	10	189	836.4	29.61	30	0.674	0.737	
Front	10	251	848.8	29.55	30	0.660	0.732	
Back	10	189	836.4	29.61	30	0.623	0.682	
Left-side	10	189	836.4	29.61	30	0.480	0.525	
Right-side	10	189	836.4	29.61	30	0.474	0.519	
Bottom	10	189	836.4	29.61	30	0.113	0.124	
Note: 1. When the reported SAR of the Mid channel for the exposure configuration is ≤ 0.8 W/kg, no further SAR testing is required in other channel.								

PCS1900 Head SAR								
SAR MEASUREMENT								
Liquid Temperature (°C) : 22.2 ±2					Relative Humidity (%) : 51%			
Ambient Temperature (°C) : 23.1 ±2					Depth of Liquid (cm) : >15			
Test Position	Dist (mm)	Frequency		Conducted Power (dBm)		SAR 1g (W/kg)		Plot No.
		Channel	MHz	Measurement	Tune-up Limit	Measurement	Tune-up Scaled	
Test Mode : PCS1900 GPRS 4UP								
Left-Cheek	0	512	1850.2	27.37	28	0.317	0.366	
Left-Cheek	0	661	1880	27.38	28	0.610	0.704	
Left-Cheek	0	810	1909.8	27.17	28	0.594	0.719	12
Left-Tilt	0	661	1880	27.38	28	0.309	0.356	
Right-Cheek	0	661	1880	27.38	28	0.470	0.542	
Right-Tilt	0	661	1880	27.38	28	0.269	0.310	
Note: 1. When the reported SAR of the Mid channel for the exposure configuration is ≤ 0.8 W/kg, no further SAR testing is required in other channel.								

PCS1900 Body SAR								
SAR MEASUREMENT								
Liquid Temperature (°C) : 22.2 ±2					Relative Humidity (%) : 51%			
Ambient Temperature (°C) : 23.1 ±2					Depth of Liquid (cm) : >15			
Test Position	Dist (mm)	Frequency		Conducted Power (dBm)		SAR 1g (W/kg)		Plot No.
		Channel	MHz	Measurement	Tune-up Limit	Measurement	Tune-up Scaled	
Test Mode : PCS1900 GPRS 4UP_10mm								
Front	10	661	1880	27.38	28	0.397	0.458	
Back	10	512	1850.2	27.37	28	1.000	1.156	13
Back	10	661	1880	27.38	28	0.852	0.983	
Back	10	810	1909.8	27.17	28	0.800	0.968	
Left-side	10	661	1880	27.38	28	0.282	0.325	
Right-side	10	661	1880	27.38	28	0.091	0.105	
Bottom	10	512	1850.2	27.37	28	0.572	0.661	
Bottom	10	661	1880	27.38	28	0.891	1.028	
Bottom	10	810	1909.8	27.17	28	0.928	1.123	
Note: 1. When the reported SAR of the Mid channel for the exposure configuration is ≤ 0.8 W/kg, no further SAR testing is required in other channel.								

WCDMA B2 Head SAR								
SAR MEASUREMENT								
Liquid Temperature (°C) : 21.7 ±2					Relative Humidity (%) : 50%			
Ambient Temperature (°C) : 22.8 ±2					Depth of Liquid (cm) : >15			
Test Position	Dist (mm)	Frequency		Conducted Power (dBm)		SAR 1g (W/kg)		Plot No.
		Channel	MHz	Measurement	Tune-up Limit	Measurement	Tune-up Scaled	
Test Mode : WCDMA B2 RMC								
Left-Cheek	0	9262	1852.4	22.37	24	0.226	0.329	
Left-Cheek	0	9400	1880	22.65	24	0.337	0.460	
Left-Cheek	0	9538	1907.6	22.46	24	0.449	0.640	14
Left-Tilt	0	9400	1880	22.65	24	0.240	0.327	
Right-Cheek	0	9400	1880	22.65	24	0.270	0.368	
Right-Tilt	0	9400	1880	22.65	24	0.211	0.288	
Note: 1. When the reported SAR of the Mid channel for the exposure configuration is ≤ 0.8 W/kg, no further SAR testing is required in other channel.								

WCDMA B2 Body SAR								
SAR MEASUREMENT								
Liquid Temperature (°C) : 21.7 ±2					Relative Humidity (%) : 50%			
Ambient Temperature (°C) : 22.8 ±2					Depth of Liquid (cm) : >15			
Test Position	Dist (mm)	Frequency		Conducted Power (dBm)		SAR 1g (W/kg)		Plot No.
		Channel	MHz	Measurement	Tune-up Limit	Measurement	Tune-up Scaled	
Test Mode : WCDMA B2 RMC_10mm								
Front	10	9400	1880	22.65	24	0.312	0.426	
Back	10	9400	1880	22.65	24	0.596	0.813	15
Left-side	10	9400	1880	22.65	24	0.198	0.270	
Right-side	10	9400	1880	22.65	24	0.067	0.091	
Bottom	10	9262	1852.4	22.37	24	0.722	1.051	
Bottom	10	9400	1880	22.65	24	0.879	1.199	16
Bottom	10	9538	1907.6	22.46	24	0.746	1.064	
Note: 1. When the reported SAR of the Mid channel for the exposure configuration is ≤ 0.8 W/kg, no further SAR testing is required in other channel.								

WCDMA B4 Head SAR								
SAR MEASUREMENT								
Liquid Temperature (°C) : 22.2 ±2					Relative Humidity (%) : 51%			
Ambient Temperature (°C) : 23.1 ±2					Depth of Liquid (cm) : >15			
Test Position	Dist (mm)	Frequency		Conducted Power (dBm)		SAR 1g (W/kg)		Plot No.
		Channel	MHz	Measurement	Tune-up Limit	Measurement	Tune-up Scaled	
Test Mode : WCDMA B4 RMC								
Left-Cheek	0	1312	1712.4	18.54	19	0.128	0.142	
Left-Cheek	0	1413	1732.6	18.83	19	0.165	0.172	
Left-Cheek	0	1513	1752.6	18.72	19	0.225	0.240	17
Left-Tilt	0	1413	1732.6	18.83	19	0.102	0.106	
Right-Cheek	0	1413	1732.6	18.83	19	0.100	0.104	
Right-Tilt	0	1413	1732.6	18.83	19	0.143	0.149	
Note: 1. When the reported SAR of the Mid channel for the exposure configuration is ≤ 0.8 W/kg, no further SAR testing is required in other channel.								

WCDMA B4 Body SAR								
SAR MEASUREMENT								
Liquid Temperature (°C) : 22.2 ±2					Relative Humidity (%) : 51%			
Ambient Temperature (°C) : 23.1 ±2					Depth of Liquid (cm) : >15			
Test Position	Dist (mm)	Frequency		Conducted Power (dBm)		SAR 1g (W/kg)		Plot No.
		Channel	MHz	Measurement	Tune-up Limit	Measurement	Tune-up Scaled	
Test Mode : WCDMA B4 RMC 10mm								
Front	10	1413	1732.6	18.83	19	0.266	0.277	
Back	10	1312	1712.4	18.54	19	0.987	1.097	18
Back	10	1413	1732.6	18.83	19	0.936	0.973	
Back	10	1513	1752.6	18.72	19	0.740	0.789	
Left-side	10	1413	1732.6	18.83	19	0.089	0.093	
Right-side	10	1413	1732.6	18.83	19	0.040	0.042	
Bottom	10	1312	1712.4	18.54	19	1.060	1.178	19
Bottom	10	1413	1732.6	18.83	19	0.962	1.000	
Bottom	10	1513	1752.6	18.72	19	0.796	0.849	
Note: 1. When the reported SAR of the Mid channel for the exposure configuration is ≤ 0.8 W/kg, no further SAR testing is required in other channel.								

WCDMA B5 Head SAR								
SAR MEASUREMENT								
Liquid Temperature (°C) : 22.1 ±2					Relative Humidity (%) : 52%			
Ambient Temperature (°C) : 23.2 ±2					Depth of Liquid (cm) : >15			
Test Position	Dist (mm)	Frequency		Conducted Power (dBm)		SAR 1g (W/kg)		Plot No.
		Channel	MHz	Measurement	Tune-up Limit	Measurement	Tune-up Scaled	
Test Mode : WCDMA B5 RMC								
Left-Cheek	0	4183	836.6	23.12	25	0.283	0.436	
Left-Tilt	0	4183	836.6	23.12	25	0.163	0.251	
Right-Cheek	0	4132	826.4	23.03	25	0.287	0.452	
Right-Cheek	0	4183	836.6	23.12	25	0.295	0.455	
Right-Cheek	0	4233	846.6	23.01	25	0.311	0.492	20
Right-Tilt	0	4183	836.6	23.12	25	0.134	0.207	
Note: 1. When the reported SAR of the Mid channel for the exposure configuration is ≤ 0.8 W/kg, no further SAR testing is required in other channel.								

WCDMA B5 Body SAR								
SAR MEASUREMENT								
Liquid Temperature (°C) : 22.1 ±2					Relative Humidity (%) : 51%			
Ambient Temperature (°C) : 23.2 ±2					Depth of Liquid (cm) : >15			
Test Position	Dist (mm)	Frequency		Conducted Power (dBm)		SAR 1g (W/kg)		Plot No.
		Channel	MHz	Measurement	Tune-up Limit	Measurement	Tune-up Scaled	
Test Mode : WCDMA B5 RMC_10mm								
Front	10	4132	826.4	23.03	25	0.248	0.390	
Front	10	4183	836.6	23.12	25	0.253	0.390	21
Front	10	4233	846.6	23.01	25	0.242	0.383	
Back	10	4183	836.6	23.12	25	0.242	0.373	
Left-side	10	4183	836.6	23.12	25	0.139	0.214	
Right-side	10	4183	836.6	23.12	25	0.150	0.231	
Bottom	10	4183	836.6	23.12	25	0.043	0.067	
Note: 1. When the reported SAR of the Mid channel for the exposure configuration is ≤ 0.8 W/kg, no further SAR testing is required in other channel.								

LTE Band 7 Head SAR										
SAR MEASUREMENT										
Liquid Temperature (°C): 21.7 ±2							Relative Humidity (%): 50			
Ambient Temperature (°C): 22.8 ±2							Depth of Liquid (cm): >15			
Test Position	Dist (mm)	RB	RB offset	Frequency		Conducted Power (dBm)		SAR 1g (W/kg)		Plot No.
				Channel	MHz	Measurement	Tune-up Limit	Measurement	Tune-up Scaled	
Test Mode : LTE Band 7 QPSK 20M										
Left-Cheek	0	1	50	20850	2510	19.35	20	0.070	0.081	22
Left-Cheek	0	1	50	21100	2535	19.37	20	0.053	0.062	
Left-Cheek	0	1	50	21350	2560	19.11	20	0.031	0.038	
Left-Cheek	0	50	0	21100	2535	17.65	19	0.041	0.056	
Left-Tilt	0	1	50	21100	2535	19.37	20	0.046	0.053	
Right-Cheek	0	1	50	21100	2535	19.37	20	0.024	0.028	
Right-Tilt	0	1	50	21100	2535	19.37	20	0.029	0.033	
Note: 1. When the reported SAR of the Mid channel for the exposure configuration is ≤ 0.8 W/kg, no further SAR testing is required in other channel.										

LTE Band 7 Body SAR										
SAR MEASUREMENT										
Liquid Temperature (°C): 21.7 ±2							Relative Humidity (%): 50			
Ambient Temperature (°C): 22.8 ±2							Depth of Liquid (cm): >15			
Test Position	Dist (mm)	RB	RB offset	Frequency		Conducted Power (dBm)		SAR 1g (W/kg)		Plot No.
				Channel	MHz	Measurement	Tune-up Limit	Measurement	Tune-up Scaled	
Test Mode : LTE Band 7 QPSK 20M_10mm										
Front	10	1	50	21100	2510	19.37	20	0.205	0.237	
Back	10	1	50	21100	2535	19.37	20	0.621	0.718	23
Left-side	10	1	50	21100	2560	19.37	20	0.051	0.058	
Right-side	10	1	50	21100	2510	19.37	20	0.116	0.134	
Bottom	10	1	50	20850	2510	19.35	20	0.900	1.045	24
Bottom	10	1	50	21100	2535	19.37	20	0.772	0.893	
Bottom	10	1	50	21350	2560	19.11	20	0.734	0.901	
Bottom	10	50	0	20850	2510	17.57	19	0.722	1.004	
Bottom	10	50	0	21100	2535	17.65	19	0.687	0.937	
Bottom	10	50	0	21350	2560	17.59	19	0.597	0.826	
Bottom	10	100	0	21100	2510	17.60	19	0.669	0.923	
Note: 1. When the reported SAR of the Mid channel for the exposure configuration is ≤ 0.8 W/kg, no further SAR testing is required in other channel.										

LTE Band 12 Head SAR										
SAR MEASUREMENT										
Liquid Temperature (°C): 22.1 ±2							Relative Humidity (%): 52			
Ambient Temperature (°C): 23.2 ±2							Depth of Liquid (cm): >15			
Test Position	Dist (mm)	RB	RB offset	Frequency		Conducted Power (dBm)		SAR 1g (W/kg)		Plot No.
				Channel	MHz	Measurement	Tune-up Limit	Measurement	Tune-up Scaled	
Test Mode : LTE Band 12 QPSK 10M										
Left-Cheek	0	1	25	23060	704	23.02	24.5	0.352	0.495	
Left-Cheek	0	1	25	23095	707.5	23.13	24.5	0.345	0.473	
Left-Cheek	0	1	25	23130	711	23.04	24.5	0.359	0.502	25
Left-Cheek	0	25	12	23095	707.5	22.01	23.5	0.257	0.362	
Left-Tilt	0	1	25	23095	707.5	23.13	24.5	0.173	0.237	
Right-Cheek	0	1	25	23095	707.5	23.13	24.5	0.344	0.472	
Right-Tilt	0	1	25	23095	707.5	23.13	24.5	0.163	0.223	
Note: 1. When the reported SAR of the Mid channel for the exposure configuration is ≤ 0.8 W/kg, no further SAR testing is required in other channel. 2. LTE Band 17 (704-716MHz) is covered by LTE Band 12 (699-716MHz)										

LTE Band 12 Body SAR										
SAR MEASUREMENT										
Liquid Temperature (°C): 22.1 ±2							Relative Humidity (%): 52			
Ambient Temperature (°C): 23.2 ±2							Depth of Liquid (cm): >15			
Test Position	Dist (mm)	RB	RB offset	Frequency		Conducted Power (dBm)		SAR 1g (W/kg)		Plot No.
				Channel	MHz	Measurement	Tune-up Limit	Measurement	Tune-up Scaled	
Test Mode : LTE Band 12 QPSK 10M_10mm										
Front	10	1	25	23060	704	23.02	24.5	0.317	0.446	
Front	10	1	25	23095	707.5	23.13	24.5	0.294	0.403	
Front	10	1	25	23130	711	23.04	24.5	0.349	0.488	26
Front	10	25	12	23095	707.5	22.01	23.5	0.257	0.362	
Back	10	1	25	23095	707.5	23.13	24.5	0.215	0.295	
Left-side	10	1	25	23095	707.5	23.13	24.5	0.211	0.289	
Right-side	10	1	25	23095	707.5	23.13	24.5	0.262	0.359	
Bottom	10	1	25	23095	707.5	23.13	24.5	0.041	0.057	
Note: 1. When the reported SAR of the Mid channel for the exposure configuration is ≤ 0.8 W/kg, no further SAR testing is required in other channel. 2. LTE Band 17 (704-716MHz) is covered by LTE Band 12 (699-716MHz)										

LTE Band 13 Head SAR										
SAR MEASUREMENT										
Liquid Temperature (°C): 22.1 ±2							Relative Humidity (%): 52			
Ambient Temperature (°C): 23.2 ±2							Depth of Liquid (cm): >15			
Test Position	Dist (mm)	RB	RB offset	Frequency		Conducted Power (dBm)		SAR 1g (W/kg)		Plot No.
				Channel	MHz	Measurement	Tune-up Limit	Measurement	Tune-up Scaled	
Test Mode : LTE Band 13 QPSK 10M										
Left-Cheek	0	1	25	23230	782	22.72	24.5	0.336	0.506	27
Left-Cheek	0	25	12	23230	782	21.82	23.5	0.240	0.353	
Left-Tilt	0	1	25	23230	782	22.72	24.5	0.172	0.259	
Right-Cheek	0	1	25	23230	782	22.72	24.5	0.323	0.487	
Right-Tilt	0	1	25	23230	782	22.72	24.5	0.156	0.235	
Note: 1. When the reported SAR of the Mid channel for the exposure configuration is ≤ 0.8 W/kg, no further SAR testing is required in other channel.										

LTE Band 13 Body SAR										
SAR MEASUREMENT										
Liquid Temperature (°C): 22.1 ±2							Relative Humidity (%): 52			
Ambient Temperature (°C): 23.2 ±2							Depth of Liquid (cm): >15			
Test Position	Dist (mm)	RB	RB offset	Frequency		Conducted Power (dBm)		SAR 1g (W/kg)		Plot No.
				Channel	MHz	Measurement	Tune-up Limit	Measurement	Tune-up Scaled	
Test Mode : LTE Band 13 QPSK 10M_10mm										
Front	10	1	25	23230	782	22.72	24.5	0.331	0.499	28
Front	10	25	12	23230	782	21.82	23.5	0.270	0.398	
Back	10	1	25	23230	782	22.72	24.5	0.306	0.461	
Left-side	10	1	25	23230	782	22.72	24.5	0.250	0.377	
Right-side	10	1	25	23230	782	22.72	24.5	0.284	0.428	
Bottom	10	1	25	23230	782	22.72	24.5	0.032	0.049	
Note: 1. When the reported SAR of the Mid channel for the exposure configuration is ≤ 0.8 W/kg, no further SAR testing is required in other channel.										

LTE Band 25 Head SAR										
SAR MEASUREMENT										
Liquid Temperature (°C): 21.7 ±2							Relative Humidity (%): 50			
Ambient Temperature (°C): 22.8 ±2							Depth of Liquid (cm): >15			
Test Position	Dist (mm)	RB	RB offset	Frequency		Conducted Power (dBm)		SAR 1g (W/kg)		Plot No.
				Channel	MHz	Measurement	Tune-up Limit	Measurement	Tune-up Scaled	
Test Mode : LTE Band 25 QPSK 20M										
Left-Cheek	0	1	50	26140	1860	22.36	23	0.356	0.413	
Left-Cheek	0	1	50	26365	1882.5	22.73	23	0.460	0.490	
Left-Cheek	0	1	50	26590	1905	22.69	23	0.522	0.561	29
Left-Cheek	0	50	25	26365	1882.5	21.55	22	0.363	0.403	
Left-Tilt	0	1	50	26365	1882.5	22.73	23	0.245	0.261	
Right-Cheek	0	1	50	26365	1882.5	22.73	23	0.294	0.313	
Right-Tilt	0	1	50	26365	1882.5	22.73	23	0.232	0.247	
Note: 1. When the reported SAR of the Mid channel for the exposure configuration is ≤ 0.8 W/kg, no further SAR testing is required in other channel. 2. LTE Band 2 (1850-1910MHz) is covered by LTE Band 25 (1850-1915MHz)										

LTE Band 25 Body SAR										
SAR MEASUREMENT										
Liquid Temperature (°C): 21.7 ±2							Relative Humidity (%): 50			
Ambient Temperature (°C): 22.8 ±2							Depth of Liquid (cm): >15			
Test Position	Dist (mm)	RB	RB offset	Frequency		Conducted Power (dBm)		SAR 1g (W/kg)		Plot No.
				Channel	MHz	Measurement	Tune-up Limit	Measurement	Tune-up Scaled	
Test Mode : LTE Band 25 QPSK 20M_10mm										
Front	10	1	50	26365	1882.5	22.73	23	0.325	0.346	
Back	10	1	50	26365	1882.5	22.73	23	0.669	0.712	30
Left-side	10	1	50	26365	1882.5	22.73	23	0.203	0.216	
Right-side	10	1	50	26365	1882.5	22.73	23	0.055	0.058	
Bottom	10	1	50	26140	1860	22.36	23	0.728	0.844	
Bottom	10	1	50	26365	1882.5	22.73	23	0.769	0.818	
Bottom	10	1	50	26590	1905	22.69	23	0.920	0.988	31
Bottom	10	50	25	26365	1882.5	21.55	22	0.675	0.749	
Bottom	10	100	0	26365	1882.5	21.46	22	0.667	0.755	
Note: 1. When the reported SAR of the Mid channel for the exposure configuration is ≤ 0.8 W/kg, no further SAR testing is required in other channel. 2. LTE Band 2 (1850-1910MHz) is covered by LTE Band 25 (1850-1915MHz)										

LTE Band 26 Head SAR										
SAR MEASUREMENT										
Liquid Temperature (°C): 22.1 ±2							Relative Humidity (%): 52			
Ambient Temperature (°C): 23.2 ±2							Depth of Liquid (cm): >15			
Test Position	Dist (mm)	RB	RB offset	Frequency		Conducted Power (dBm)		SAR 1g (W/kg)		Plot No.
				Channel	MHz	Measurement	Tune-up Limit	Measurement	Tune-up Scaled	
Test Mode : LTE Band 26 QPSK 15M										
Left-Cheek	0	1	36	26865	831.5	23.79	24	0.362	0.380	
Left-Cheek	0	1	36	26915	836.5	23.91	24	0.411	0.420	32
Left-Cheek	0	1	36	26965	841.5	23.45	24	0.366	0.415	
Left-Cheek	0	36	18	26915	836.5	22.68	23	0.314	0.338	
Left-Tilt	0	1	36	26915	836.5	23.91	24	0.222	0.227	
Right-Cheek	0	1	36	26915	836.5	23.91	24	0.408	0.417	
Right-Tilt	0	1	36	26915	836.5	23.91	24	0.213	0.217	
Note: 1. When the reported SAR of the Mid channel for the exposure configuration is ≤ 0.8 W/kg, no further SAR testing is required in other channel. 2. LTE Band 5 (824-849MHz) is covered by LTE Band 26 (814-849MHz)										

LTE Band 26 Body SAR										
SAR MEASUREMENT										
Liquid Temperature (°C): 22.1 ±2							Relative Humidity (%): 52			
Ambient Temperature (°C): 23.2 ±2							Depth of Liquid (cm): >15			
Test Position	Dist (mm)	RB	RB offset	Frequency		Conducted Power (dBm)		SAR 1g (W/kg)		Plot No.
				Channel	MHz	Measurement	Tune-up Limit	Measurement	Tune-up Scaled	
Test Mode : LTE Band 26 QPSK 15M_10mm										
Front	10	1	36	26865	831.5	23.79	24	0.316	0.332	
Front	10	1	36	26915	836.5	23.91	24	0.355	0.362	33
Front	10	1	36	26965	841.5	23.45	24	0.307	0.348	
Front	10	36	18	26915	836.5	22.68	23	0.277	0.298	
Back	10	1	36	26915	836.5	23.91	24	0.281	0.287	
Left-side	10	1	36	26915	836.5	23.91	24	0.235	0.240	
Right-side	10	1	36	26915	836.5	23.91	24	0.249	0.254	
Bottom	10	1	36	26915	836.5	23.91	24	0.068	0.069	
Note: 1. When the reported SAR of the Mid channel for the exposure configuration is ≤ 0.8 W/kg, no further SAR testing is required in other channel. 2. LTE Band 5 (824-849MHz) is covered by LTE Band 26 (814-849MHz)										

LTE Band 41 Head SAR										
SAR MEASUREMENT										
Liquid Temperature (°C): 21.7 ±2							Relative Humidity (%): 50			
Ambient Temperature (°C): 22.8 ±2							Depth of Liquid (cm): >15			
Test Position	Dist (mm)	RB	RB offset	Frequency		Conducted Power (dBm)		SAR 1g (W/kg)		Plot No.
				Channel	MHz	Measurement	Tune-up Limit	Measurement	Tune-up Scaled	
Test Mode : LTE Band 41 QPSK 20M										
Left-Cheek	0	1	50	40240	2555	22.34	23	0.010	0.012	
Left-Cheek	0	1	50	40620	2593	22.60	23	0.017	0.019	34
Left-Cheek	0	1	50	41140	2645	22.07	23	0.011	0.014	
Left-Cheek	0	50	25	40620	2593	21.54	22	0.011	0.012	
Left-Tilt	0	1	50	40620	2593	22.60	23	0.012	0.013	
Right-Cheek	0	1	50	40620	2593	22.60	23	0.00634	0.007	
Right-Tilt	0	1	50	40620	2593	22.60	23	0.00647	0.007	
Note: 1. When the reported SAR of the Mid channel for the exposure configuration is ≤ 0.8 W/kg, no further SAR testing is required in other channel. 2. LTE Band 38 (2570-2620 MHz) is covered by LTE Band 41 (2496-2690MHz)										

LTE Band 41 Body SAR										
SAR MEASUREMENT										
Liquid Temperature (°C): 21.7 ±2							Relative Humidity (%): 50			
Ambient Temperature (°C): 22.8 ±2							Depth of Liquid (cm): >15			
Test Position	Dist (mm)	RB	RB offset	Frequency		Conducted Power (dBm)		SAR 1g (W/kg)		Plot No.
				Channel	MHz	Measurement	Tune-up Limit	Measurement	Tune-up Scaled	
Test Mode : LTE Band 41 QPSK 20M_10mm										
Front	10	1	50	40620	2593	22.60	23	0.166	0.182	
Back	10	1	50	40240	2555	22.34	23	0.656	0.764	35
Back	10	1	50	40620	2593	22.60	23	0.671	0.736	
Back	10	1	50	41140	2645	22.07	23	0.450	0.557	
Back	10	50	25	40620	2593	21.54	22	0.454	0.505	
Left-side	10	1	50	40620	2593	22.60	23	0.041	0.045	
Right-side	10	1	50	40620	2593	22.60	23	0.082	0.090	
Bottom	10	1	50	40620	2593	22.60	23	0.517	0.567	
Note: 1. When the reported SAR of the Mid channel for the exposure configuration is ≤ 0.8 W/kg, no further SAR testing is required in other channel. 2. LTE Band 38 (2570-2620 MHz) is covered by LTE Band 41 (2496-2690MHz)										

LTE Band 66 Head SAR										
SAR MEASUREMENT										
Liquid Temperature (°C): 22.2 ±2							Relative Humidity (%): 51			
Ambient Temperature (°C): 23.1 ±2							Depth of Liquid (cm): >15			
Test Position Head	Dist (mm)	RB	RB offset	Frequency		Conducted Power (dBm)		SAR 1g (W/kg)		Plot No.
				Channel	MHz	Measurement	Tune-up Limit	Measurement	Tune-up Scaled	
Test Mode : LTE Band 66 QPSK 20M										
Left-Cheek	0	1	50	132072	1720	17.94	19	0.132	0.168	
Left-Cheek	0	1	50	132322	1745	18.01	19	0.139	0.175	
Left-Cheek	0	1	50	132572	1770	17.96	19	0.144	0.183	36
Left-Cheek	0	50	0	132322	1745	16.89	18	0.116	0.150	
Left-Tilt	0	1	50	132322	1745	18.01	19	0.068	0.086	
Right-Cheek	0	1	50	132322	1745	18.01	19	0.100	0.126	
Right-Tilt	0	1	50	132322	1745	18.01	19	0.104	0.131	
Note: 1. When the reported SAR of the Mid channel for the exposure configuration is ≤ 0.8 W/kg, no further SAR testing is required in other channel. 2. LTE Band 4 (1710-1755 MHz) is covered by LTE Band 66 (1710-1780 MHz)										

LTE Band 66 Hotspot & Body-worn SAR										
SAR MEASUREMENT										
Liquid Temperature (°C): 22.2 ±2							Relative Humidity (%): 51			
Ambient Temperature (°C): 23.1 ±2							Depth of Liquid (cm): >15			
Test Position Body	Dist (mm)	RB	RB offset	Frequency		Conducted Power (dBm)		SAR 1g (W/kg)		Plot No.
				Channel	MHz	Measurement	Tune-up Limit	Measurement	Tune-up Scaled	
Test Mode : LTE Band 66 QPSK 20M_10mm										
Front	10	1	50	132322	1745	18.01	19	0.176	0.221	
Back	10	1	50	132322	1745	18.01	19	0.536	0.673	37
Left-side	10	1	50	132322	1745	18.01	19	0.068	0.085	
Right-side	10	1	50	132322	1745	18.01	19	0.033	0.042	
Bottom	10	1	50	132072	1720	17.94	19	0.734	0.937	38
Bottom	10	1	50	132322	1745	18.01	19	0.578	0.726	
Bottom	10	1	50	132572	1770	17.96	19	0.454	0.577	
Bottom	10	50	0	132322	1745	16.89	18	0.560	0.723	
Bottom	10	100	0	132322	1745	16.80	18	0.464	0.612	
Note: 1. When the reported SAR of the Mid channel for the exposure configuration is ≤ 0.8 W/kg, no further SAR testing is required in other channel. 2. LTE Band 4 (1710-1755 MHz) is covered by LTE Band 66 (1710-1780 MHz)										

9.2 Simultaneous Transmission

Simultaneous Transmission Configurations	
1	WWAN + WLAN 2.4GHz + BT
2	WWAN + WLAN 5GHz + BT

Worst Case SAR_Head Exposure Conditions

WWAN BAND	Left-Cheek	Left-Tilt	Right-Cheek	Right-Tilt
GSM850	0.676	0.531	0.900	0.561
PCS1900	0.719	0.356	0.542	0.310
WCDMA B2	0.640	0.327	0.368	0.288
WCDMA B4	0.240	0.106	0.104	0.149
WCDMA B5	0.436	0.251	0.492	0.207
LTE Band 7	0.081	0.053	0.028	0.033
LTE Band 12(17)	0.502	0.237	0.472	0.223
LTE Band 13	0.506	0.259	0.487	0.235
LTE Band 25(2)	0.561	0.261	0.313	0.247
LTE Band 26(5)	0.420	0.227	0.417	0.217
LTE Band 41(38)	0.019	0.013	0.007	0.007
LTE Band 66(4)	0.183	0.086	0.126	0.131
WLAN BAND	Left-Cheek	Left-Tilt	Right-Cheek	Right-Tilt
WLAN 2.4G	0.833	0.499	0.348	0.244
WLAN 5G	1.087	0.977	0.744	0.870
BT	0.052	0.027	0.033	0.012

Worst Case SAR_Hotspot & Body-worn Exposure Conditions

WWAN Band	Front	Back	Left-side	Right-side	Top	Bottom
GSM850	0.919	0.682	0.525	0.519	--	0.124
PCS1900	0.458	1.156	0.325	0.105	--	1.123
WCDMA B2	0.426	0.813	0.270	0.091	--	1.199
WCDMA B4	0.277	1.097	0.093	0.042	--	1.178
WCDMA B5	0.390	0.373	0.214	0.231	--	0.067
LTE Band 7	0.237	0.718	0.058	0.134	--	1.045
LTE Band 12(17)	0.488	0.295	0.289	0.359	--	0.057
LTE Band 13	0.499	0.461	0.377	0.428	--	0.049
LTE Band 25(2)	0.346	0.712	0.216	0.058	--	0.988
LTE Band 26(5)	0.362	0.287	0.240	0.254	--	0.069
LTE Band 41(38)	0.182	0.764	0.045	0.090	--	0.567
LTE Band 66(4)	0.221	0.673	0.085	0.042	--	0.937
WLAN Band	Front	Back	Left-side	Right-side	Top	Bottom
WLAN 2.4G	0.104	0.211	--	0.122	0.116	--
WLAN 5G	0.269	0.338	--	0.108	0.272	--
BT	0.012	0.015	--	0.008	0.007	--

Worst Case SAR_Product Specific 10g (Extremity) Exposure Conditions

WLAN Band	Front	Back	Left-side	Right-side	Top	Bottom
WLAN 2.4G	0.510	0.535	--	0.293	0.246	--
WLAN 5G	0.333	0.400	--	0.114	0.682	--
BT	0.054	0.057	--	0.031	0.020	--

9.2.1 Simultaneous transmission of Wi-Fi and other wireless technologies

Head Exposure Conditions

Simultaneous Transmission Summation Scenario

Test Position	Worst Case WWAN Band	1	2	3	4	1+2+4	1+3+4
		WWAN (W/kg)	DTS (W/kg)	UNII (W/kg)	BT (W/kg)	Σ 1-g SAR	Σ 1-g SAR
Left-Cheek	PCS1900	0.719	0.833	1.087	0.052	1.604	1.858
Left-Tilt	GSM850	0.531	0.499	0.977	0.027	1.057	1.535
Right-Cheek	GSM850	0.900	0.348	0.744	0.033	1.281	1.677
Right-Tilt	GSM850	0.561	0.244	0.870	0.012	0.817	1.443

Note: The sum of value is less than 1.6 W/kg, thus simultaneous SAR testing is not needed.

Test Position	Configurations	Simultaneous Transmission (W/kg)	Antenna pair in mm	Peak location separation ratio
Left-Cheek	1+2+4	1.604	73.55	0.028
Left-Cheek	1+3+4	1.858	77.71	0.033
Right-Cheek	1+3+4	1.677	60.67	0.036

Note: The ratio of value is less than 0.04, thus simultaneous SAR testing is not needed.

Hotspot & Body-worn Exposure Conditions

Simultaneous Transmission Summation Scenario

Test Position	Worst Case WWAN Band	1	2	3	4	1+2+4	1+3+4
		WWAN (W/kg)	DTS (W/kg)	UNII (W/kg)	BT (W/kg)	Σ 1-g SAR	Σ 1-g SAR
Front	GSM850	0.919	0.104	0.269	0.012	1.035	1.200
Back	PCS1900	1.156	0.211	0.338	0.015	1.382	1.509
Left-side	GSM850	0.525	--	--	--	0.525	0.525
Right-side	GSM 850	0.519	0.122	0.108	0.008	0.649	0.635
Top	--	--	0.116	0.272	0.007	0.123	0.279
Bottom	WCDMA B2	1.199	--	--	--	1.199	1.199

Note: The sum of value is less than 1.6 W/kg, thus simultaneous SAR testing is not needed.

Product Specific 10g (Extremity) Exposure Conditions

Simultaneous Transmission Summation Scenario

Test Position	1	2	3	1+3	2+3
	DTS (W/kg)	UNII (W/kg)	BT (W/kg)		
				Σ 10-g SAR	Σ 10-g SAR
Front	0.510	0.333	0.054	0.564	0.387
Back	0.535	0.400	0.057	0.592	0.457
Right-side	0.293	0.114	0.031	0.324	0.145
Top	0.246	0.682	0.020	0.266	0.702

Note: The sum of value is less than 4 W/kg, thus simultaneous SAR testing is not needed.

10. SAR measurement variability

- 1) Repeated measurement is not required when the original highest measured SAR is < 0.80 W/kg; steps 2) through 4) do not apply.
- 2) When the original highest measured SAR is ≥ 0.80 W/kg, repeat that measurement once.
- 3) Perform a second repeated measurement only if the ratio of largest to smallest SAR for the original and first repeated measurements is > 1.20 or when the original or repeated measurement is ≥ 1.45 W/kg ($\sim 10\%$ from the 1-g SAR limit).
- 4) Perform a third repeated measurement only if the original, first or second repeated measurement is ≥ 1.5 W/kg and the ratio of largest to smallest SAR for the original, first and second repeated measurements is > 1.20 .

Frequency				SAR 1g (W/kg)							
Mode	Band	Channel	MHz	Original	First Repeated		Second Repeated		Third Repeated		
					Value	Ratio	Value	Ratio	Value	Ratio	
WLAN	2.4G	1	2412	0.810	0.778	1.041	N/A	N/A	N/A	N/A	
WLAN	5G	138	5690	1.070	1.040	1.029	N/A	N/A	N/A	N/A	
GSM	850	128	824.2	0.836	0.832	1.005	N/A	N/A	N/A	N/A	
PCS	1900	10	512	1.000	0.973	1.028	N/A	N/A	N/A	N/A	
WCDMA	B2	9400	1880	0.879	0.806	1.091	N/A	N/A	N/A	N/A	
WCDMA	B4	1312	1712.4	1.060	1.020	1.039	N/A	N/A	N/A	N/A	
LTE	B7	20850	2510	0.900	0.865	1.040	N/A	N/A	N/A	N/A	
LTE	B25	26590	1905	0.920	0.892	1.031	N/A	N/A	N/A	N/A	

Appendix

Appendix A. SAR System Check Data

Appendix B. SAR measurement Data

Appendix C. Test Setup Photographs

Appendix D. Probe Calibration Data

Appendix E. Dipole Calibration Data

Appendix F. Product Photos-Please refer to the file: 22A0299R-Product Photos

Appendix A. SAR System Check Data

Test Laboratory: DEKRA

Date: 2022/12/18

System Performance Check_750MHz-Head

DUT: Dipole 750 MHz; Type: D750V3

Communication System: UID 0, CW; Frequency: 750 MHz;

Communication System PAR: 0 dB

Medium parameters used: $f = 750 \text{ MHz}$; $\sigma = 0.88 \text{ S/m}$; $\epsilon_r = 41.86$; $\rho = 1000 \text{ kg/m}^3$

Phantom section: Flat Section

Ambient Temperature ($^{\circ}\text{C}$) : 23.2, Liquid Temperature ($^{\circ}\text{C}$) : 22.1

Measurement Standard: DASYS5 (IEEE/IEC/ANSI C63.19-2011)

DASY5 Configuration:

- Probe: EX3DV4 - SN3979; ConvF(10.47, 10.47, 10.47); Calibrated: 2022/11/23;
- Sensor-Surface: 1.4mm (Mechanical Surface Detection)
- Electronics: DAE4 Sn1425; Calibrated: 2022/11/23
- Phantom: SAM with right table; Type: SAM;
- Measurement SW: DASYS52, Version 52.10 (0); SEMCAD X Version 14.6.10 (7417)

Configuration/750MHz-Head/Area Scan (8x13x1): Measurement grid: $dx=15\text{mm}$, $dy=15\text{mm}$

Maximum value of SAR (measured) = 2.42 W/kg

Configuration/750MHz-Head/Zoom Scan (5x5x7)/Cube 0: Measurement grid: $dx=8\text{mm}$, $dy=8\text{mm}$, $dz=5\text{mm}$

Reference Value = 58.57 V/m; Power Drift = 0.03 dB

Peak SAR (extrapolated) = 3.05 W/kg

SAR(1 g) = 2.04 W/kg; SAR(10 g) = 1.33 W/kg

Maximum value of SAR (measured) = 2.76 W/kg

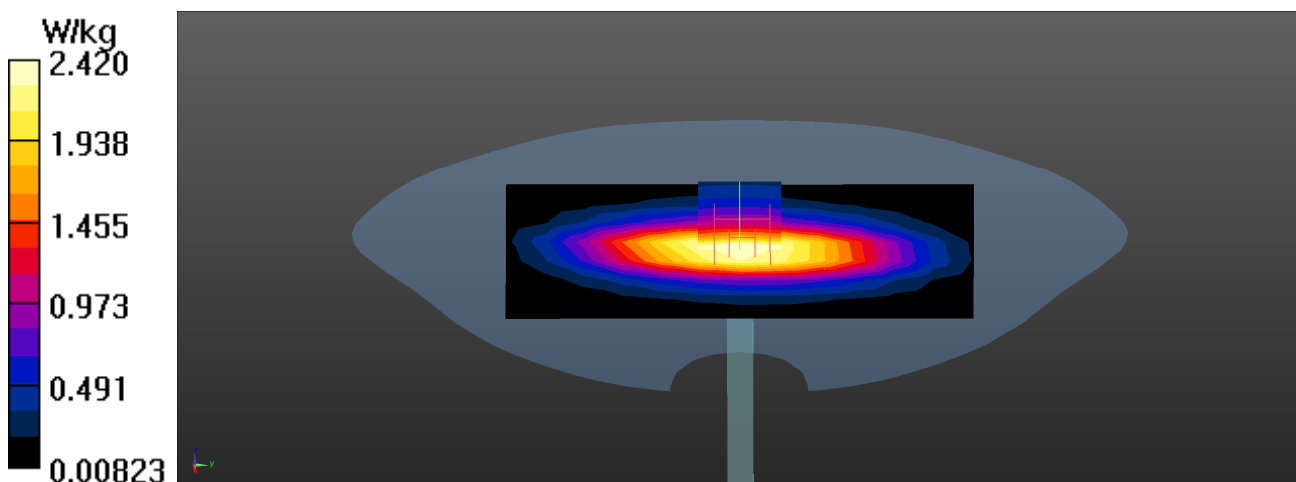

Test Laboratory: DEKRA

Date: 2022/12/27

System Performance Check_750MHz-Head**DUT: Dipole 750 MHz; Type: D750V3**

Communication System: UID 0, CW; Frequency: 750 MHz;

Communication System PAR: 0 dB

Medium parameters used: $f = 750$ MHz; $\sigma = 0.87$ S/m; $\epsilon_r = 41.88$; $\rho = 1000$ kg/m³

Phantom section: Flat Section

Ambient Temperature (°C) : 23.1, Liquid Temperature (°C) : 22.2

Measurement Standard: DASYS5 (IEEE/IEC/ANSI C63.19-2011)

DASY5 Configuration:

- Probe: EX3DV4 - SN3979; ConvF(10.47, 10.47, 10.47); Calibrated: 2022/11/23;
- Sensor-Surface: 1.4mm (Mechanical Surface Detection)
- Electronics: DAE4 Sn1425; Calibrated: 2022/11/23
- Phantom: SAM with right table; Type: SAM;
- Measurement SW: DASYS52, Version 52.10 (0); SEMCAD X Version 14.6.10 (7417)

Configuration/750MHz-Head/Area Scan (8x13x1): Measurement grid: dx=15mm, dy=15mm

Maximum value of SAR (measured) = 2.48 W/kg

Configuration/750MHz-Head/Zoom Scan (5x5x7)/Cube 0: Measurement grid: dx=8mm, dy=8mm, dz=5mm

Reference Value = 59.08 V/m; Power Drift = 0.06 dB

Peak SAR (extrapolated) = 3.21 W/kg

SAR(1 g) = 2.09 W/kg; SAR(10 g) = 1.29 W/kg

Maximum value of SAR (measured) = 2.83 W/kg

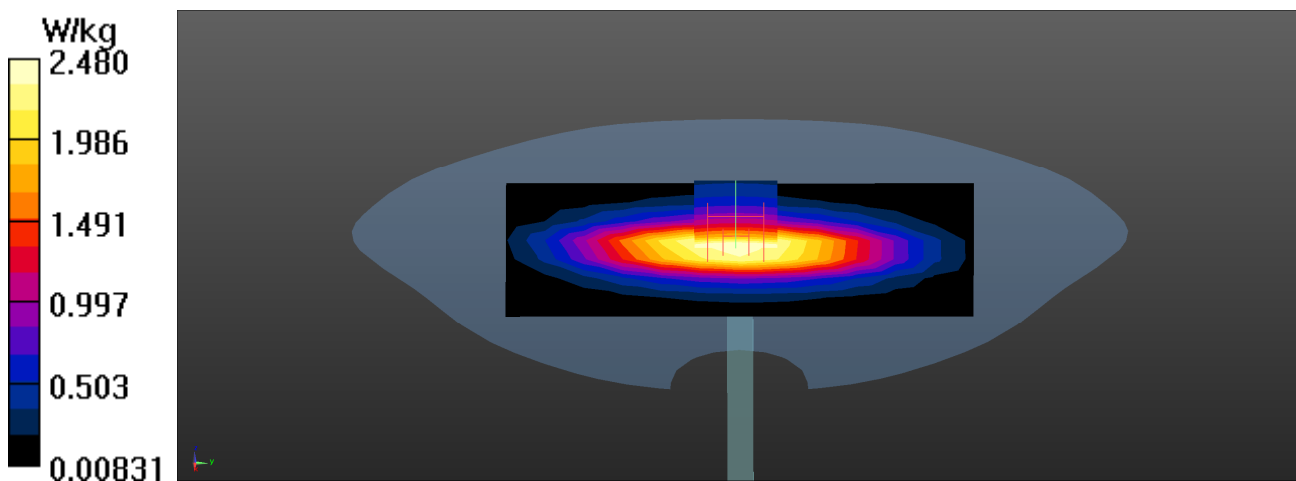

Test Laboratory: DEKRA

Date: 2022/12/27

System Performance Check_1750MHz-Head**DUT: Dipole 1750 MHz; Type: D1750V2**

Communication System: UID 0, CW; Frequency: 1750 MHz;

Communication System PAR: 0 dB

Medium parameters used: $f = 1750$ MHz; $\sigma = 1.37$ S/m; $\epsilon_r = 39.59$; $\rho = 1000$ kg/m³

Phantom section: Flat Section

Ambient Temperature (°C) : 23.1, Liquid Temperature (°C) : 22.2

Measurement Standard: DASY5 (IEEE/IEC/ANSI C63.19-2011)

DASY5 Configuration:

- Probe: EX3DV4 - SN3979; ConvF(8.34, 8.34, 8.34); Calibrated: 2022/11/23;
- Sensor-Surface: 1.4mm (Mechanical Surface Detection)
- Electronics: DAE4 Sn1425; Calibrated: 2022/11/23
- Phantom: SAM with right table; Type: SAM;
- Measurement SW: DASY52, Version 52.10 (0); SEMCAD X Version 14.6.10 (7417)

Configuration/1750MHz-Head/Area Scan (8x8x1): Measurement grid: dx=15mm, dy=15mm

Maximum value of SAR (measured) = 9.51 W/kg

Configuration/1750MHz-Head/Zoom Scan (5x5x7)/Cube 0: Measurement grid: dx=8mm, dy=8mm, dz=5mm

Reference Value = 102.0 V/m; Power Drift = 0.01 dB

Peak SAR (extrapolated) = 16.5 W/kg

SAR(1 g) = 8.69 W/kg; SAR(10 g) = 4.57 W/kg

Maximum value of SAR (measured) = 13.7 W/kg

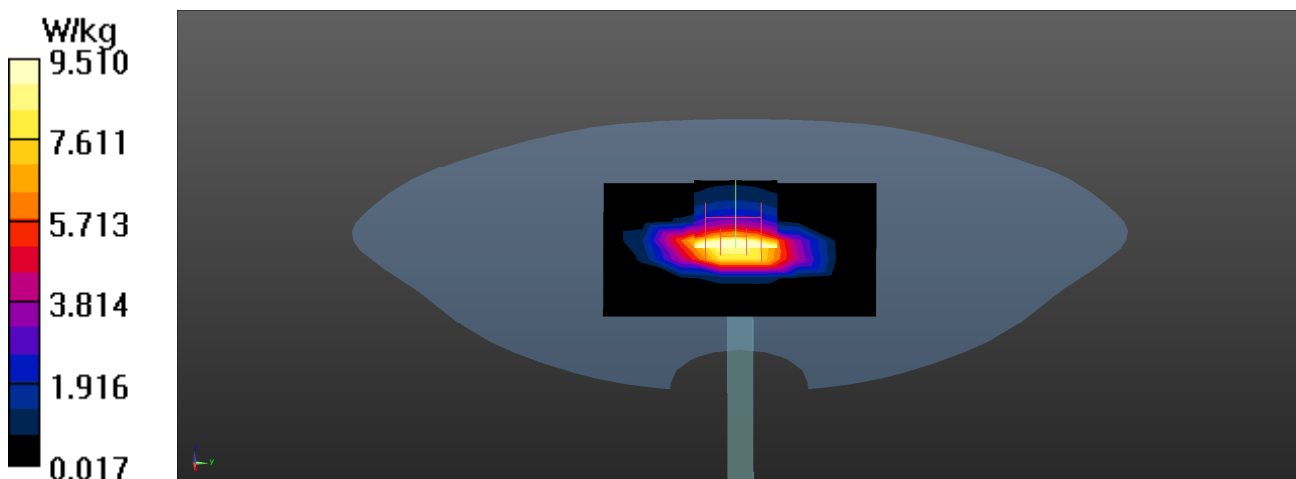

Test Laboratory: DEKRA

Date: 2022/12/17

System Performance Check_1950MHz-Head**DUT: Dipole 1950 MHz; Type: D1950V3**

Communication System: UID 0, CW ; Frequency: 1950 MHz;

Communication System PAR: 0 dB

Medium parameters used: $f = 1950$ MHz; $\sigma = 1.39$ S/m; $\epsilon_r = 39.54$; $\rho = 1000$ kg/m³

Phantom section: Flat Section

Ambient Temperature (°C) : 22.8, Liquid Temperature (°C) : 21.7

Measurement Standard: DASY5 (IEEE/IEC/ANSI C63.19-2011)

DASY5 Configuration:

- Probe: EX3DV4 - SN3979; ConvF(8.12, 8.12, 8.12); Calibrated: 2022/11/23;
- Sensor-Surface: 1.4mm (Mechanical Surface Detection)
- Electronics: DAE4 Sn1425; Calibrated: 2022/11/23
- Phantom: SAM with right table; Type: SAM;
- Measurement SW: DASY52, Version 52.10 (0); SEMCAD X Version 14.6.10 (7417)

Configuration/1950MHz-Head/Area Scan (8x8x1): Measurement grid: dx=15mm, dy=15mm

Maximum value of SAR (measured) = 11.4 W/kg

Configuration/1950MHz-Head/Zoom Scan (5x5x7)/Cube 0: Measurement grid: dx=8mm, dy=8mm, dz=5mm

Reference Value = 115.4 V/m; Power Drift = 0.06 dB

Peak SAR (extrapolated) = 20.7 W/kg

SAR(1 g) = 10.5 W/kg; SAR(10 g) = 5.44 W/kg

Maximum value of SAR (measured) = 17.3 W/kg

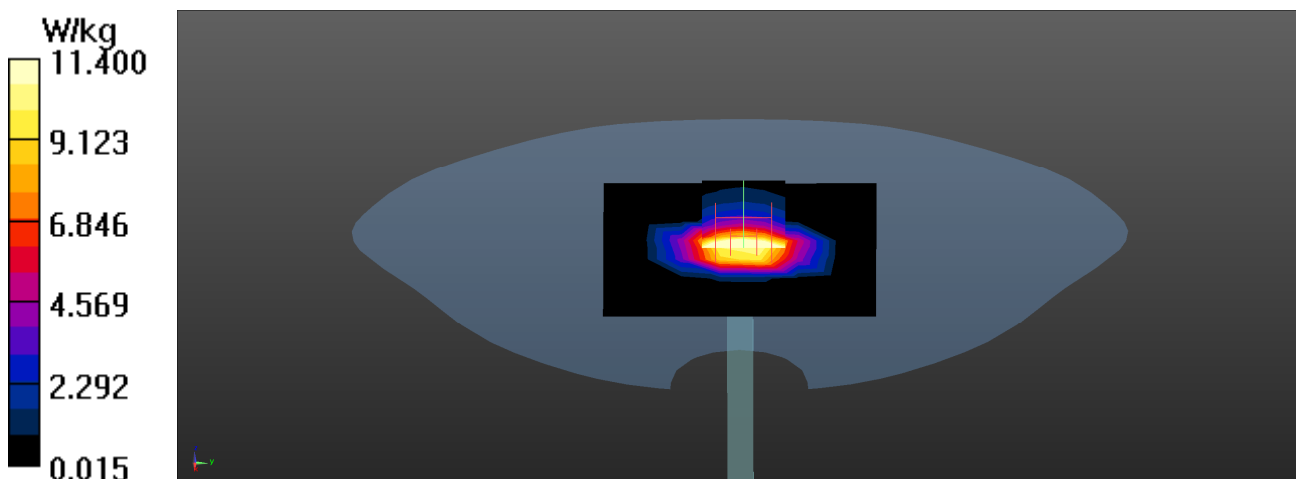

Test Laboratory: DEKRA

Date: 2022/12/27

System Performance Check_1950MHz-Head**DUT: Dipole 1950 MHz; Type: D1950V3**

Communication System: UID 0, CW ; Frequency: 1950 MHz;

Communication System PAR: 0 dB

Medium parameters used: $f = 1950$ MHz; $\sigma = 1.42$ S/m; $\epsilon_r = 38.81$; $\rho = 1000$ kg/m³

Phantom section: Flat Section

Ambient Temperature (°C) : 23.1, Liquid Temperature (°C) : 22.2

Measurement Standard: DASYS5 (IEEE/IEC/ANSI C63.19-2011)

DASY5 Configuration:

- Probe: EX3DV4 - SN3979; ConvF(8.12, 8.12, 8.12); Calibrated: 2022/11/23;
- Sensor-Surface: 1.4mm (Mechanical Surface Detection)
- Electronics: DAE4 Sn1425; Calibrated: 2022/11/23
- Phantom: SAM with right table; Type: SAM;
- Measurement SW: DASYS52, Version 52.10 (0); SEMCAD X Version 14.6.10 (7417)

Configuration/1950MHz-Head/Area Scan (8x8x1): Measurement grid: dx=15mm, dy=15mm

Maximum value of SAR (measured) = 11.0 W/kg

Configuration/1950MHz-Head/Zoom Scan (5x5x7)/Cube 0: Measurement grid: dx=8mm, dy=8mm, dz=5mm

Reference Value = 114.2 V/m; Power Drift = 0.06 dB

Peak SAR (extrapolated) = 19.5 W/kg

SAR(1 g) = 10.1 W/kg; SAR(10 g) = 5.31 W/kg

Maximum value of SAR (measured) = 16.9 W/kg

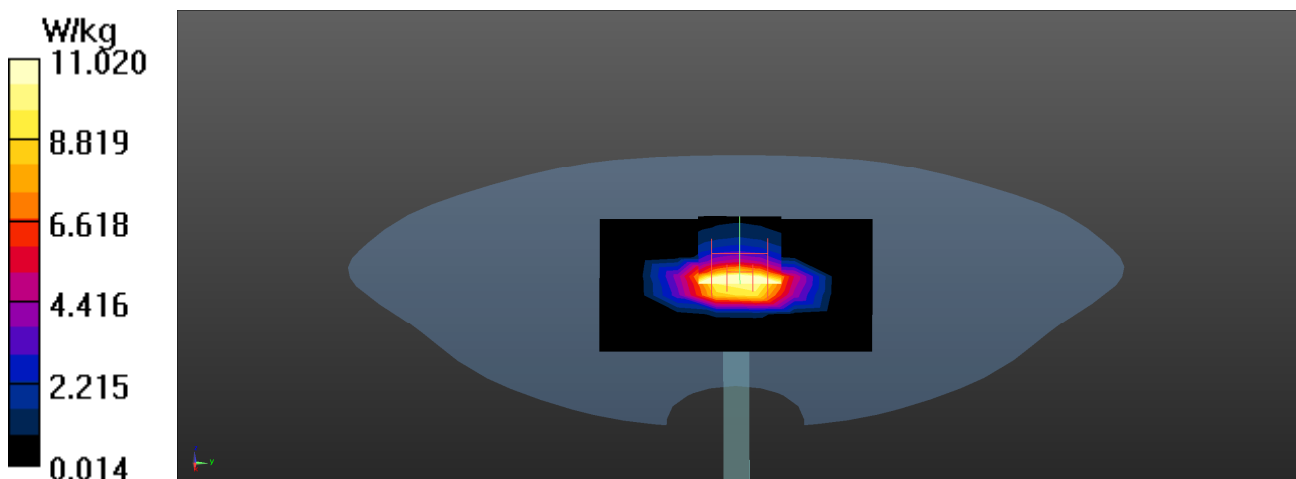

Test Laboratory: DEKRA

Date: 2022/12/12

System Performance Check_2450MHz-Head**DUT: Dipole 2450 MHz; Type: D2450V2**

Communication System: UID 0, CW; Frequency: 2450 MHz;

Communication System PAR: 0 dB

Medium parameters used: $f = 2450$ MHz; $\sigma = 1.79$ S/m; $\epsilon_r = 39.98$; $\rho = 1000$ kg/m³

Phantom section: Flat Section

Ambient Temperature (°C) : 22.7, Liquid Temperature (°C) : 21.9

Measurement Standard: DASYS (IEEE/IEC/ANSI C63.19-2011)

DASY5 Configuration:

- Probe: EX3DV4 - SN3979; ConvF(7.58, 7.58, 7.58); Calibrated: 2022/11/23;
- Sensor-Surface: 1.4mm (Mechanical Surface Detection)
- Electronics: DAE4 Sn1425; Calibrated: 2022/11/23
- Phantom: SAM with right table; Type: SAM;
- Measurement SW: DASYS2, Version 52.10 (0); SEMCAD X Version 14.6.10 (7417)

Configuration/2450MHz-Head/Area Scan (8x9x1): Measurement grid: dx=12mm, dy=12mm

Maximum value of SAR (measured) = 19.7 W/kg

Configuration/2450MHz-Head/Zoom Scan (7x7x7)/Cube 0: Measurement grid: dx=5mm, dy=5mm, dz=5mm

Reference Value = 115.8 V/m; Power Drift = 0.05 dB

Peak SAR (extrapolated) = 26.2 W/kg

SAR(1 g) = 13.3 W/kg; SAR(10 g) = 6.08 W/kg

Maximum value of SAR (measured) = 22.5 W/kg

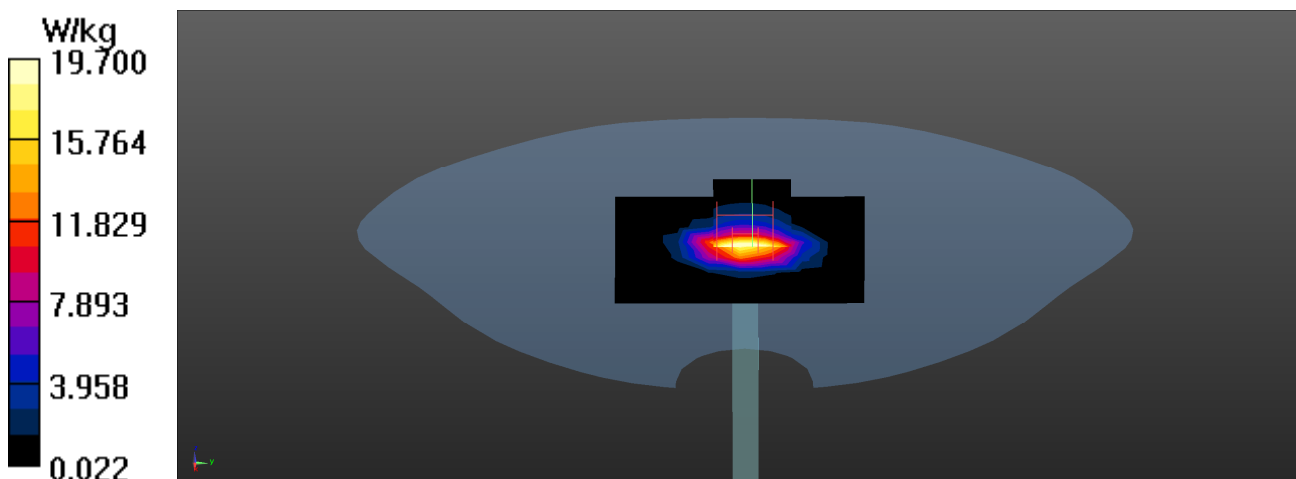

Test Laboratory: DEKRA

Date: 2022/12/17

System Performance Check_2600MHz-Head**DUT: Dipole_2600MHz; Type: ALS-D-2600-S-2**

Communication System: UID 0, CW; Frequency: 2600 MHz;

Communication System PAR: 0 dB

Medium parameters used: $f = 2600$ MHz; $\sigma = 1.95$ S/m; $\epsilon_r = 38.01$; $\rho = 1000$ kg/m³

Phantom section: Flat Section

Ambient Temperature (°C) : 22.8, Liquid Temperature (°C) : 21.7

Measurement Standard: DASYS5 (IEEE/IEC/ANSI C63.19-2011)

DASY5 Configuration:

- Probe: EX3DV4 - SN3979; ConvF(7.38, 7.38, 7.38); Calibrated: 2022/11/23;
- Sensor-Surface: 1.4mm (Mechanical Surface Detection)
- Electronics: DAE4 Sn1425; Calibrated: 2022/11/23
- Phantom: SAM with right table; Type: SAM;
- Measurement SW: DASYS52, Version 52.10 (0); SEMCAD X Version 14.6.10 (7417)

Configuration/2600MHz-Head/Area Scan (9x9x1): Measurement grid: dx=12mm, dy=12mm

Maximum value of SAR (measured) = 16.5 W/kg

Configuration/2600MHz-Head/Zoom Scan (7x7x7)/Cube 0: Measurement grid: dx=5mm, dy=5mm, dz=5mm

Reference Value = 120.2 V/m; Power Drift = -0.01 dB

Peak SAR (extrapolated) = 30.7 W/kg

SAR(1 g) = 14.6 W/kg; SAR(10 g) = 6.48 W/kg

Maximum value of SAR (measured) = 25.9 W/kg

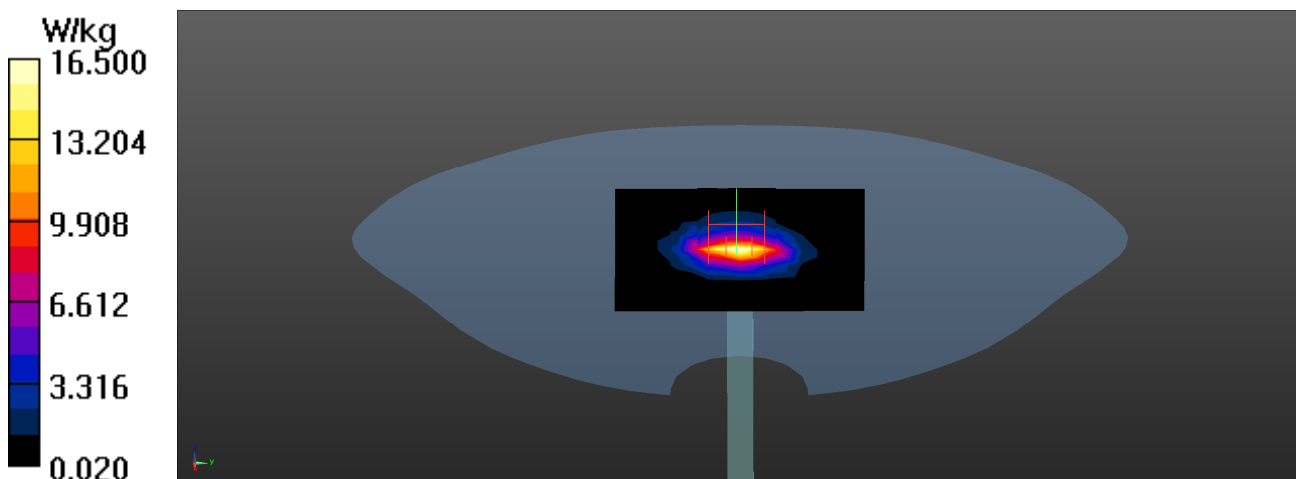

Test Laboratory: DEKRA

Date: 2022/12/10

System Performance Check_5250MHz-Head**DUT: Dipole 5GHz; Type: D5GHzV2**

Communication System: UID 0, CW; Frequency: 5250 MHz;

Communication System PAR: 0 dB

Medium parameters used: $f = 5250$ MHz; $\sigma = 4.58$ S/m; $\epsilon_r = 35.96$; $\rho = 1000$ kg/m³

Phantom section: Flat Section

Ambient Temperature (°C) : 22.8, Liquid Temperature (°C) : 21.8

Measurement Standard: DASYS5 (IEEE/IEC/ANSI C63.19-2011)

DASY5 Configuration:

- Probe: EX3DV4 - SN3979; ConvF(4.8, 4.8, 4.8); Calibrated: 2022/11/23;
- Sensor-Surface: 1.4mm (Mechanical Surface Detection)
- Electronics: DAE4 Sn1425; Calibrated: 2022/11/23
- Phantom: SAM with right table; Type: SAM;
- Measurement SW: DASYS52, Version 52.10 (0); SEMCAD X Version 14.6.10 (7417)

Configuration/5250MHz-Head/Area Scan (8x8x1): Measurement grid: dx=10mm, dy=10mm

Maximum value of SAR (measured) = 16.0 W/kg

Configuration/5250MHz-Head/Zoom Scan (7x7x7)/Cube 0: Measurement grid: dx=4mm, dy=4mm, dz=1.4mm

Reference Value = 63.30 V/m; Power Drift = 0.11 dB

Peak SAR (extrapolated) = 30.9 W/kg

SAR(1 g) = 8.42 W/kg; SAR(10 g) = 2.39 W/kg

Maximum value of SAR (measured) = 21.6 W/kg

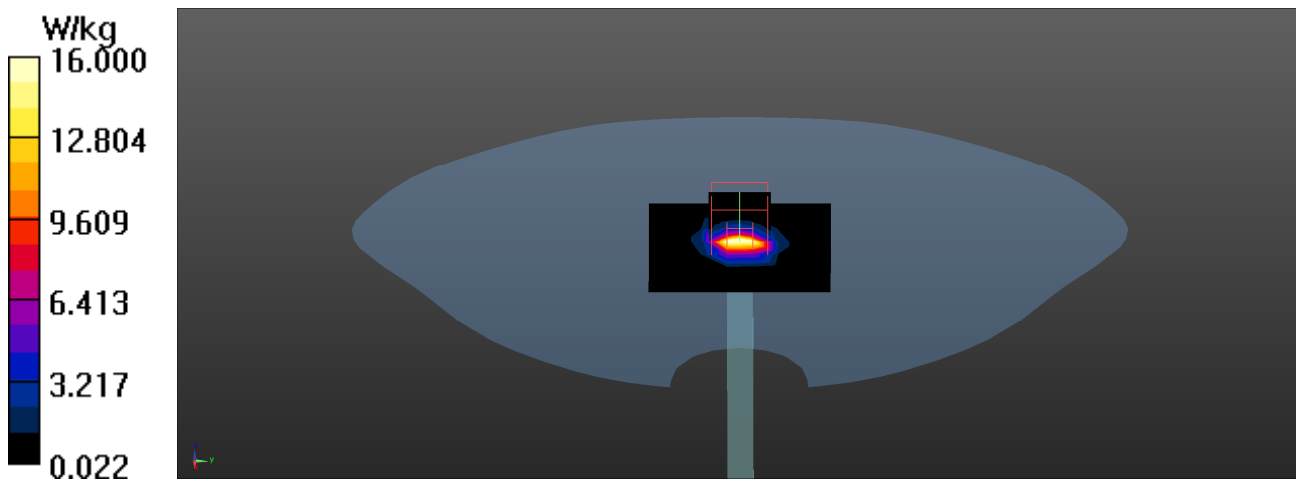

Test Laboratory: DEKRA

Date: 2022/12/10

System Performance Check_5600MHz-Head**DUT: Dipole 5GHz; Type: D5GHzV2**

Communication System: UID 0, CW; Frequency: 5600 MHz;

Communication System PAR: 0 dB

Medium parameters used: $f = 5600$ MHz; $\sigma = 5.06$ S/m; $\epsilon_r = 34.99$; $\rho = 1000$ kg/m³

Phantom section: Flat Section

Ambient Temperature (°C) : 22.8, Liquid Temperature (°C) : 21.8

Measurement Standard: DASYS5 (IEEE/IEC/ANSI C63.19-2011)

DASY5 Configuration:

- Probe: EX3DV4 - SN3979; ConvF(4.42, 4.42, 4.42); Calibrated: 2022/11/23;
- Sensor-Surface: 1.4mm (Mechanical Surface Detection)
- Electronics: DAE4 Sn1425; Calibrated: 2022/11/23
- Phantom: SAM with right table; Type: SAM;
- Measurement SW: DASYS52, Version 52.10 (0); SEMCAD X Version 14.6.10 (7417)

Configuration/5600MHz-Head/Area Scan (8x8x1): Measurement grid: dx=10mm, dy=10mm

Maximum value of SAR (measured) = 14.0 W/kg

Configuration/5600MHz-Head/Zoom Scan (7x7x7)/Cube 0: Measurement grid:

dx=4mm, dy=4mm, dz=1.4mm

Reference Value = 74.44 V/m; Power Drift = -0.05 dB

Peak SAR (extrapolated) = 34.4 W/kg

SAR(1 g) = 8.98 W/kg; SAR(10 g) = 2.53 W/kg

Maximum value of SAR (measured) = 23.5 W/kg

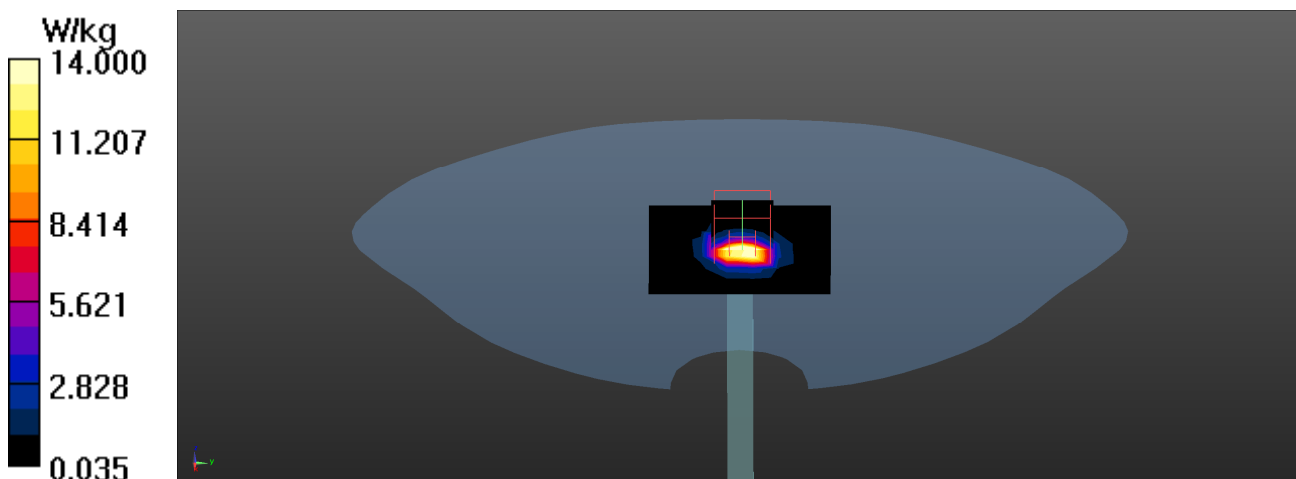

Test Laboratory: DEKRA

Date: 2022/12/10

System Performance Check_5800MHz-Head**DUT: Dipole 5GHz; Type: D5GHzV2**

Communication System: UID 0, CW; Frequency: 5800 MHz;

Communication System PAR: 0 dB

Medium parameters used: $f = 5800$ MHz; $\sigma = 5.32$ S/m; $\epsilon_r = 34.44$; $\rho = 1000$ kg/m³

Phantom section: Flat Section

Ambient Temperature (°C) : 22.8, Liquid Temperature (°C) : 21.8

Measurement Standard: DASY5 (IEEE/IEC/ANSI C63.19-2011)

DASY5 Configuration:

- Probe: EX3DV4 - SN3979; ConvF(4.4, 4.4, 4.4); Calibrated: 2022/11/23;
- Sensor-Surface: 1.4mm (Mechanical Surface Detection)
- Electronics: DAE4 Sn1425; Calibrated: 2022/11/23
- Phantom: SAM with right table; Type: SAM;
- Measurement SW: DASY52, Version 52.10 (0); SEMCAD X Version 14.6.10 (7417)

Configuration/5800MHz-Head/Area Scan (8x8x1): Measurement grid: dx=10mm, dy=10mm

Maximum value of SAR (measured) = 13.9 W/kg

Configuration/5800MHz-Head/Zoom Scan (7x7x7)/Cube 0: Measurement grid:

dx=4mm, dy=4mm, dz=1.4mm

Reference Value = 72.65 V/m; Power Drift = -0.01 dB

Peak SAR (extrapolated) = 36.4 W/kg

SAR(1 g) = 8.68 W/kg; SAR(10 g) = 2.45 W/kg

Maximum value of SAR (measured) = 23.4 W/kg

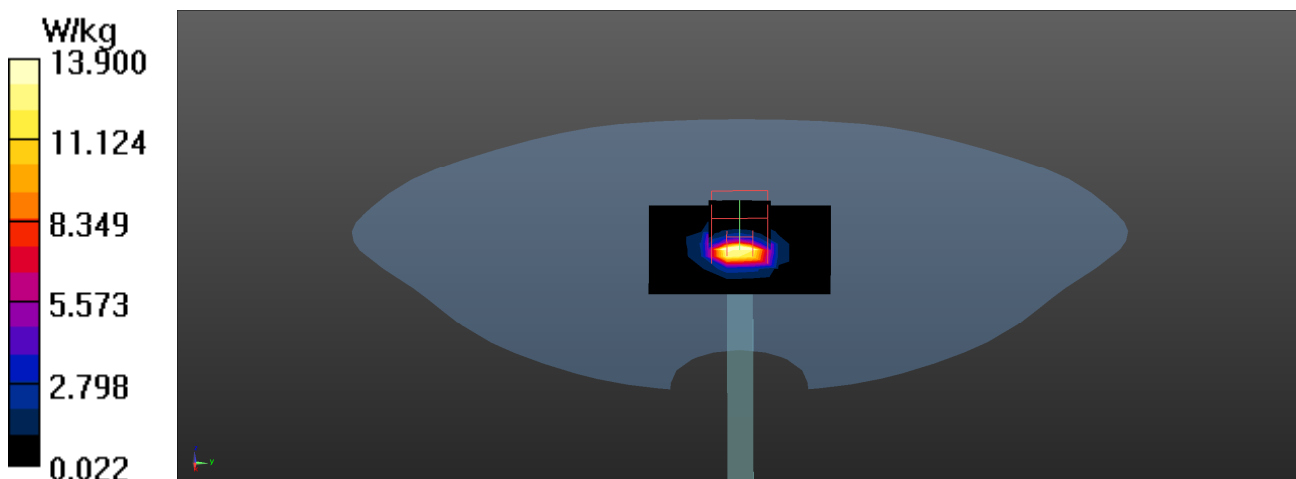

Appendix B. SAR measurement Data

Test Laboratory: DEKRA

Date: 2022/12/12

01_802.11b_1_Left-Cheek Main

DUT: Mobile Computer; Type: RS36

Communication System: UID 0, WLAN 2.4G; Frequency: 2412 MHz;

Communication System PAR: 0 dB

Medium parameters used: $f = 2412$ MHz; $\sigma = 1.74$ S/m; $\epsilon_r = 40.13$; $\rho = 1000$ kg/m³

Phantom section: Flat Section

Ambient Temperature (°C) : 22.7, Liquid Temperature (°C) : 21.9

Measurement Standard: DASYS (IEEE/IEC/ANSI C63.19-2011)

DASY5 Configuration:

- Probe: EX3DV4 - SN3979; ConvF(7.58, 7.58, 7.58); Calibrated: 2022/11/23;
- Sensor-Surface: 1.4mm (Mechanical Surface Detection)
- Electronics: DAE4 Sn1425; Calibrated: 2022/11/23
- Phantom: SAM with right table; Type: SAM;
- Measurement SW: DASYS2, Version 52.10 (0); SEMCAD X Version 14.6.10 (7417)

Configuration/Head/Area Scan (9x18x1): Measurement grid: dx=12mm, dy=12mm
Maximum value of SAR (measured) = 1.20 W/kg

Configuration/Head/Zoom Scan (7x7x7)/Cube 0: Measurement grid: dx=5mm, dy=5mm, dz=5mm

Reference Value = 26.41 V/m; Power Drift = 0.00 dB

Peak SAR (extrapolated) = 1.58 W/kg

SAR(1 g) = 0.810 W/kg; SAR(10 g) = 0.393 W/kg

Maximum value of SAR (measured) = 1.25 W/kg

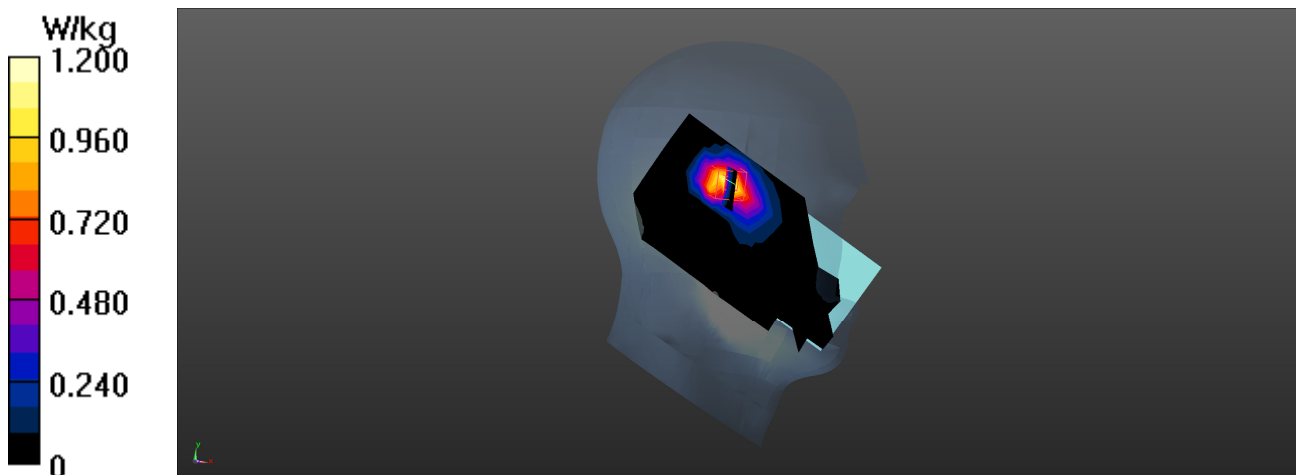

Test Laboratory: DEKRA

Date: 2022/12/12

02_BT-1M_0_Left-Check Main**DUT: Mobile Computer; Type: RS36**

Communication System: UID 0, BT 1M&3M&BLE; Frequency: 2402 MHz;

Communication System PAR: 0 dB

Medium parameters used: $f = 2402$ MHz; $\sigma = 1.73$ S/m; $\epsilon_r = 40.16$; $\rho = 1000$ kg/m³

Phantom section: Flat Section

Ambient Temperature (°C) : 22.7, Liquid Temperature (°C) : 21.9

Measurement Standard: DASY5 (IEEE/IEC/ANSI C63.19-2011)

DASY5 Configuration:

- Probe: EX3DV4 - SN3979; ConvF(7.58, 7.58, 7.58); Calibrated: 2022/11/23;
- Sensor-Surface: 1.4mm (Mechanical Surface Detection)
- Electronics: DAE4 Sn1425; Calibrated: 2022/11/23
- Phantom: SAM with right table; Type: SAM;
- Measurement SW: DASY52, Version 52.10 (0); SEMCAD X Version 14.6.10 (7417)

Configuration/Head/Area Scan (9x18x1): Measurement grid: dx=12mm, dy=12mm

Maximum value of SAR (measured) = 0.0732 W/kg

Configuration/Head/Zoom Scan (7x7x7)/Cube 0: Measurement grid: dx=5mm, dy=5mm, dz=5mm

Reference Value = 0.6610 V/m; Power Drift = 0.11 dB

Peak SAR (extrapolated) = 0.101 W/kg

SAR(1 g) = 0.046 W/kg; SAR(10 g) = 0.019 W/kg

Maximum value of SAR (measured) = 0.0806 W/kg

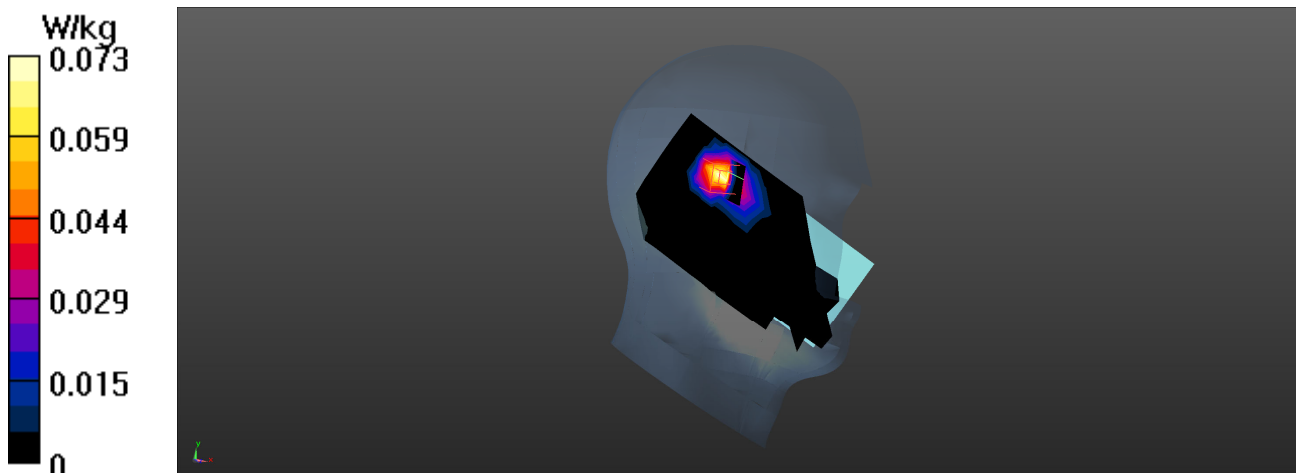

802.11b EUT Left-Cheek_0mm_Head (Main Antenna), Z-Axis plot

Channel: 1

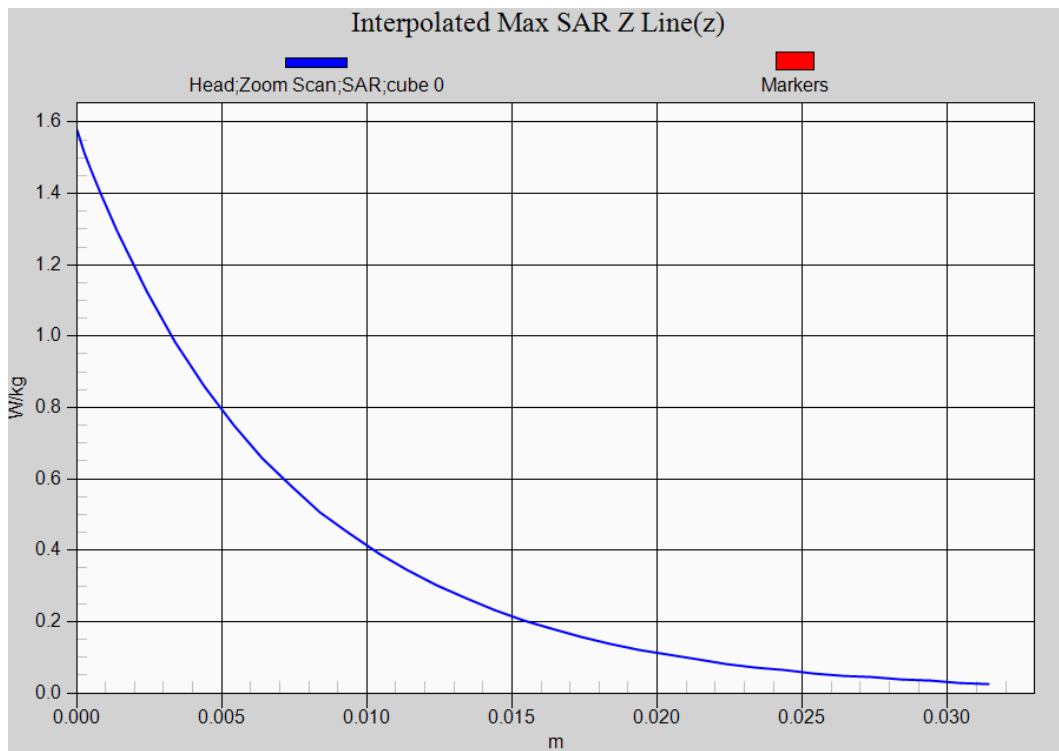

Test Laboratory: DEKRA

Date: 2022/12/12

03_802.11b_11-Back Main 10mm**DUT: Mobile Computer; Type: RS36**

Communication System: UID 0, WLAN 2.4G; Frequency: 2462 MHz;

Communication System PAR: 0 dB

Medium parameters used: $f = 2462$ MHz; $\sigma = 1.81$ S/m; $\epsilon_r = 39.94$; $\rho = 1000$ kg/m³

Phantom section: Flat Section

Ambient Temperature (°C) : 22.7, Liquid Temperature (°C) : 21.9

Measurement Standard: DASYS5 (IEEE/IEC/ANSI C63.19-2011)

DASY5 Configuration:

- Probe: EX3DV4 - SN3979; ConvF(7.58, 7.58, 7.58); Calibrated: 2022/11/23;
- Sensor-Surface: 1.4mm (Mechanical Surface Detection)
- Electronics: DAE4 Sn1425; Calibrated: 2022/11/23
- Phantom: SAM with right table; Type: SAM;
- Measurement SW: DASYS52, Version 52.10 (0); SEMCAD X Version 14.6.10 (7417)

Configuration/Flat/Area Scan (10x17x1): Measurement grid: dx=12mm, dy=12mm

Maximum value of SAR (measured) = 0.291 W/kg

Configuration/Flat/Zoom Scan (7x7x7)/Cube 0: Measurement grid: dx=5mm, dy=5mm, dz=5mm

Reference Value = 13.54 V/m; Power Drift = -0.07 dB

Peak SAR (extrapolated) = 0.376 W/kg

SAR(1 g) = 0.204 W/kg; SAR(10 g) = 0.112 W/kg

Maximum value of SAR (measured) = 0.310 W/kg

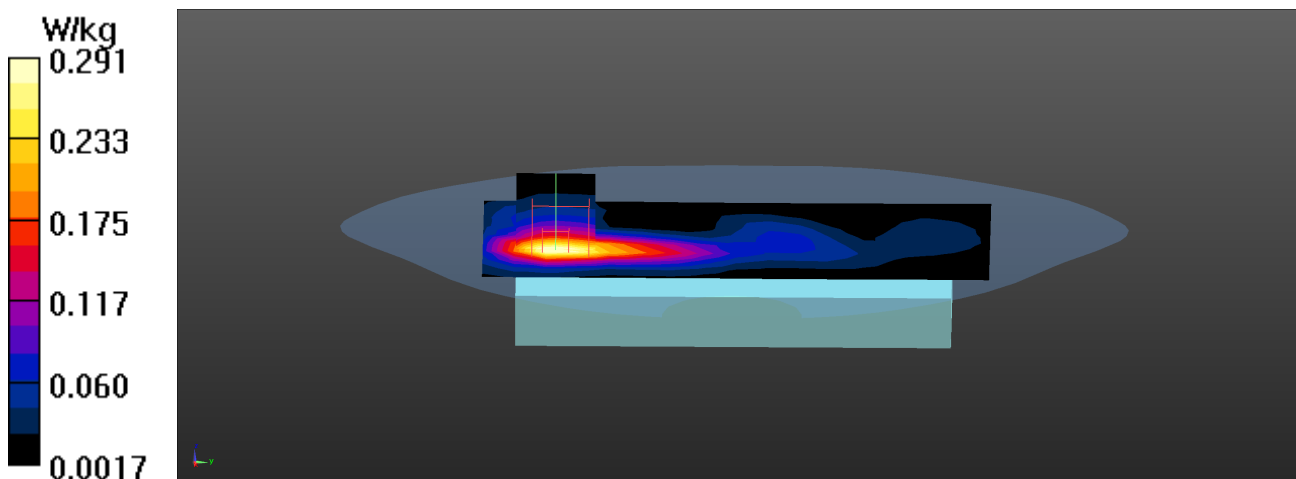

Test Laboratory: DEKRA

Date: 2022/12/12

04_BT-1M_0-Back Main 10mm**DUT: Mobile Computer; Type: RS36**

Communication System: UID 0, BT 1M&3M&BLE; Frequency: 2402 MHz;

Communication System PAR: 0 dB

Medium parameters used: $f = 2402$ MHz; $\sigma = 1.73$ S/m; $\epsilon_r = 40.16$; $\rho = 1000$ kg/m³

Phantom section: Flat Section

Ambient Temperature (°C) : 22.7, Liquid Temperature (°C) : 21.9

Measurement Standard: DASYS5 (IEEE/IEC/ANSI C63.19-2011)

DASY5 Configuration:

- Probe: EX3DV4 - SN3979; ConvF(7.58, 7.58, 7.58); Calibrated: 2022/11/23;
- Sensor-Surface: 1.4mm (Mechanical Surface Detection)
- Electronics: DAE4 Sn1425; Calibrated: 2022/11/23
- Phantom: SAM with right table; Type: SAM;
- Measurement SW: DASYS52, Version 52.10 (0); SEMCAD X Version 14.6.10 (7417)

Configuration/Flat/Area Scan (10x17x1): Measurement grid: dx=12mm, dy=12mm

Maximum value of SAR (measured) = 0.0201 W/kg

Configuration/Flat/Zoom Scan (7x7x7)/Cube 0: Measurement grid: dx=5mm, dy=5mm, dz=5mm

Reference Value = 1.675 V/m; Power Drift = -0.17 dB

Peak SAR (extrapolated) = 0.0260 W/kg

SAR(1 g) = 0.013 W/kg; SAR(10 g) = 0.00683 W/kg

Maximum value of SAR (measured) = 0.0208 W/kg

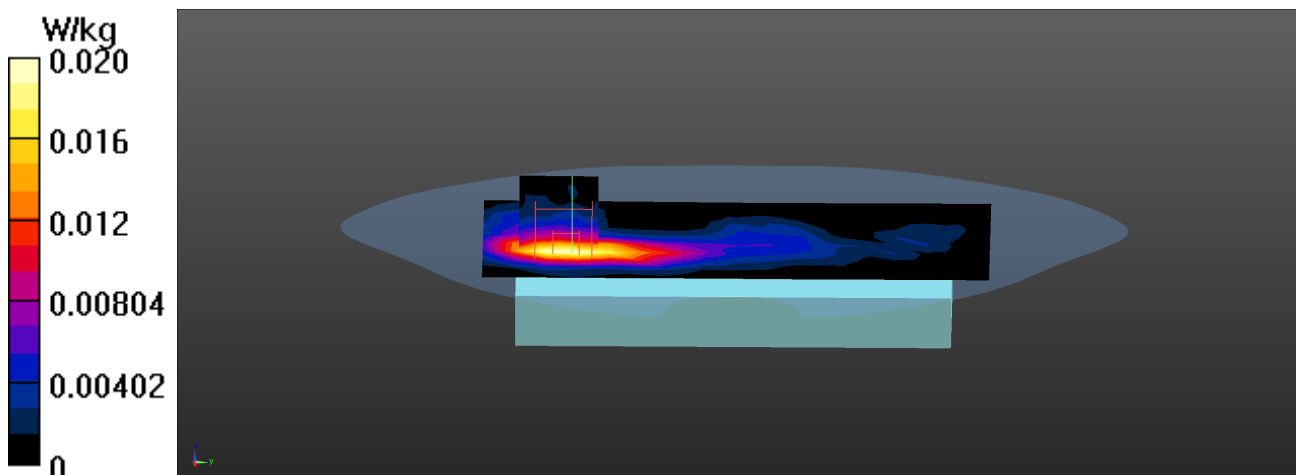

802.11b EUT Back_10mm_Body (Main Antenna), Z-Axis plot

Channel: 11

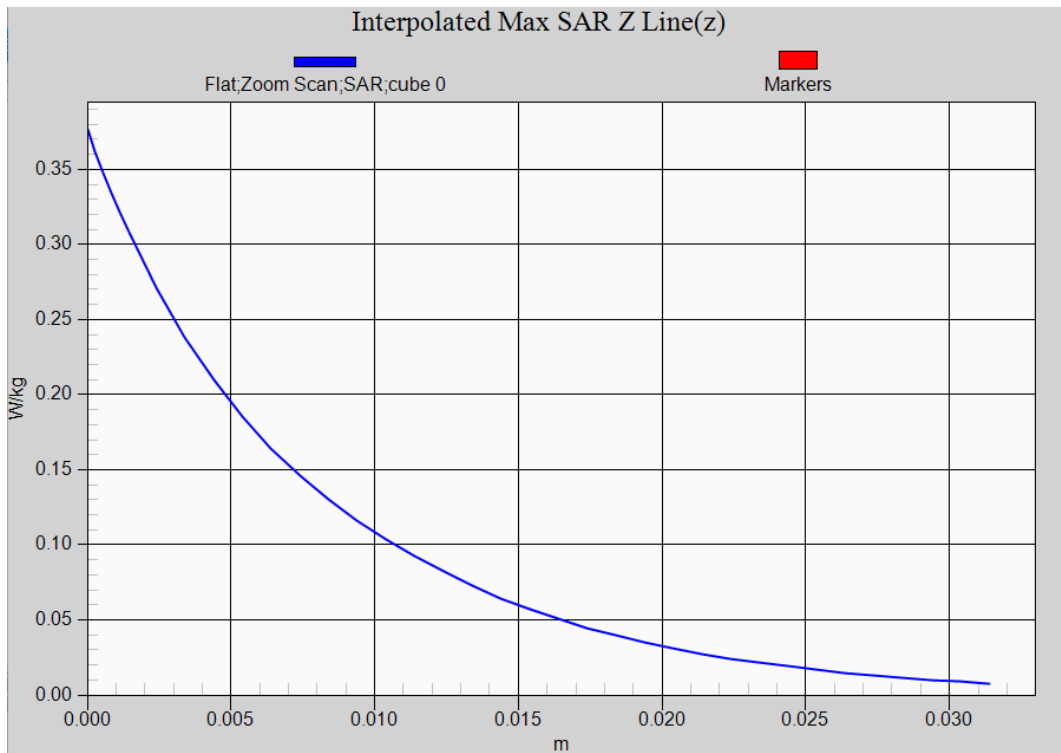

Test Laboratory: DEKRA

Date: 2022/12/12

05_802.11b_6-Back Main 0mm**DUT: Mobile Computer; Type: RS36**

Communication System: UID 0, WLAN 2.4G; Frequency: 2437 MHz;

Communication System PAR: 0 dB

Medium parameters used: $f = 2437$ MHz; $\sigma = 1.77$ S/m; $\epsilon_r = 40.03$; $\rho = 1000$ kg/m³

Phantom section: Flat Section

Ambient Temperature (°C) : 22.7, Liquid Temperature (°C) : 21.9

Measurement Standard: DASYS5 (IEEE/IEC/ANSI C63.19-2011)

DASY5 Configuration:

- Probe: EX3DV4 - SN3979; ConvF(7.58, 7.58, 7.58); Calibrated: 2022/11/23;
- Sensor-Surface: 1.4mm (Mechanical Surface Detection)
- Electronics: DAE4 Sn1425; Calibrated: 2022/11/23
- Phantom: SAM with right table; Type: SAM;
- Measurement SW: DASYS52, Version 52.10 (0); SEMCAD X Version 14.6.10 (7417)

Configuration/Flat/Area Scan (10x17x1): Measurement grid: dx=12mm, dy=12mm

Maximum value of SAR (measured) = 1.63 W/kg

Configuration/Flat/Zoom Scan (7x7x7)/Cube 0: Measurement grid: dx=5mm, dy=5mm, dz=5mm

Reference Value = 5.978 V/m; Power Drift = -0.09 dB

Peak SAR (extrapolated) = 2.32 W/kg

SAR(1 g) = 1.13 W/kg; SAR(10 g) = 0.525 W/kg

Maximum value of SAR (measured) = 1.83 W/kg

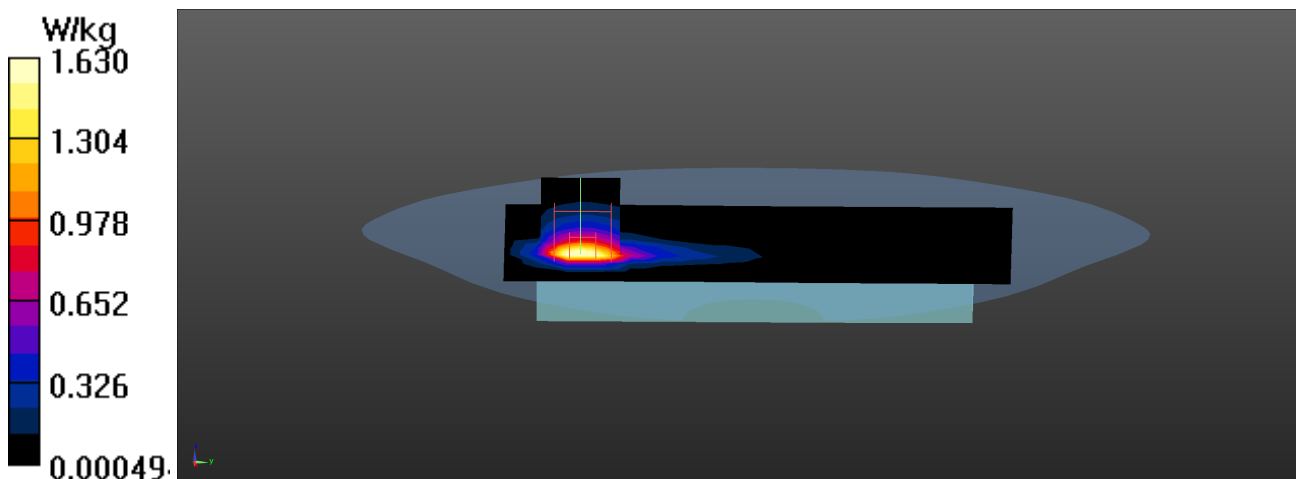

Test Laboratory: DEKRA

Date: 2022/12/12

06_BT-1M_0-Back Main 0mm**DUT: Mobile Computer; Type: RS36**

Communication System: UID 0, BT 1M&3M&BLE; Frequency: 2402 MHz;

Communication System PAR: 0 dB

Medium parameters used: $f = 2402$ MHz; $\sigma = 1.73$ S/m; $\epsilon_r = 40.16$; $\rho = 1000$ kg/m³

Phantom section: Flat Section

Ambient Temperature (°C) : 22.7, Liquid Temperature (°C) : 21.9

Measurement Standard: DASYS5 (IEEE/IEC/ANSI C63.19-2011)

DASY5 Configuration:

- Probe: EX3DV4 - SN3979; ConvF(7.58, 7.58, 7.58); Calibrated: 2022/11/23;
- Sensor-Surface: 1.4mm (Mechanical Surface Detection)
- Electronics: DAE4 Sn1425; Calibrated: 2022/11/23
- Phantom: SAM with right table; Type: SAM;
- Measurement SW: DASYS52, Version 52.10 (0); SEMCAD X Version 14.6.10 (7417)

Configuration/Flat/Area Scan (10x17x1): Measurement grid: dx=12mm, dy=12mm

Maximum value of SAR (measured) = 0.156 W/kg

Configuration/Flat/Zoom Scan (7x7x7)/Cube 0: Measurement grid: dx=5mm, dy=5mm, dz=5mm

Reference Value = 10.34 V/m; Power Drift = 0.02 dB

Peak SAR (extrapolated) = 0.215 W/kg

SAR(1 g) = 0.107 W/kg; SAR(10 g) = 0.051 W/kg

Maximum value of SAR (measured) = 0.173 W/kg

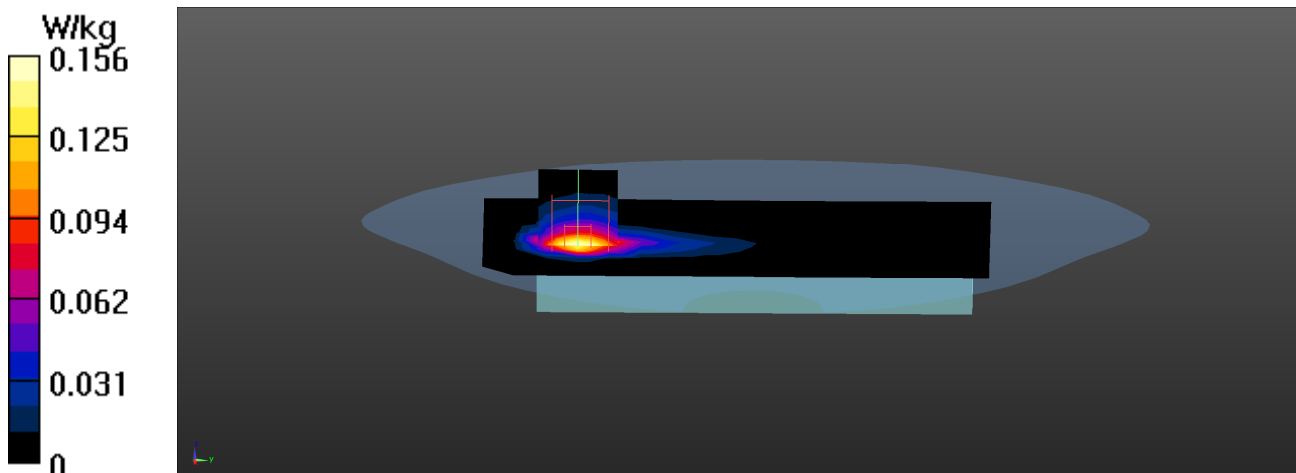

802.11b EUT Back_0mm_Body (Main Antenna), Z-Axis plot

Channel: 6

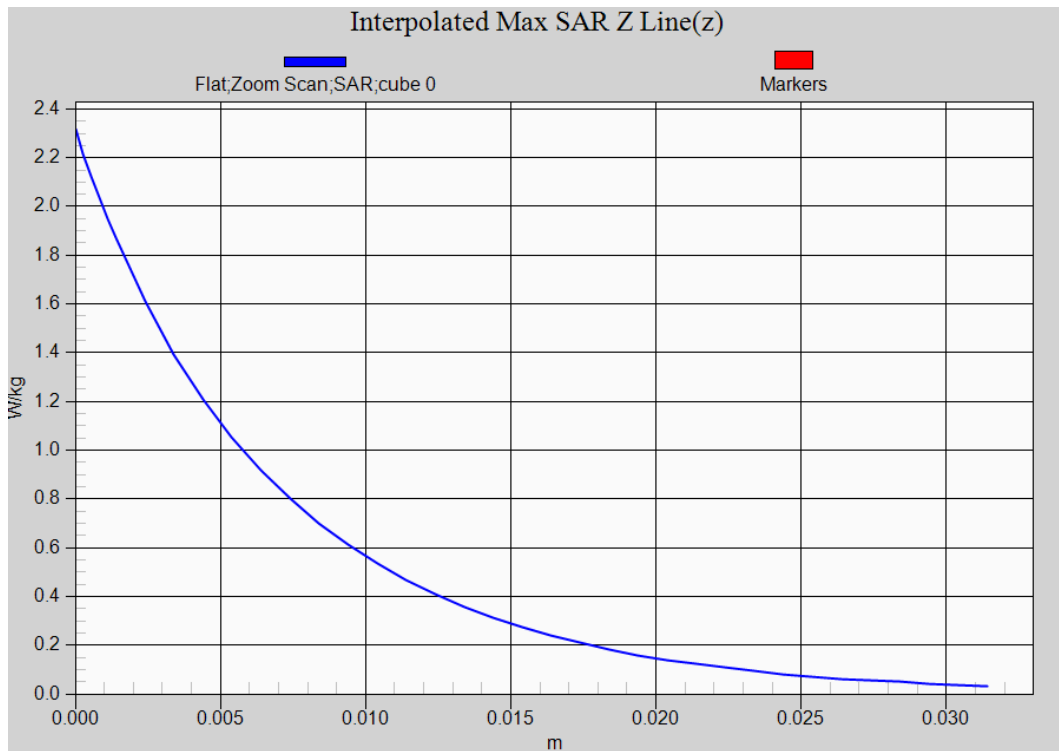

Test Laboratory: DEKRA

Date: 2022/12/10

07_802.11ac80M_138_Left-Check Main**DUT: Mobile Computer; Type: RS36**

Communication System: UID 0, WLAN 5G; Frequency: 5690 MHz;

Communication System PAR: 0 dB

Medium parameters used: $f = 5690$ MHz; $\sigma = 5.17$ S/m; $\epsilon_r = 34.75$; $\rho = 1000$ kg/m³

Phantom section: Flat Section

Ambient Temperature (°C) : 22.8, Liquid Temperature (°C) : 21.8

Measurement Standard: DASYS5 (IEEE/IEC/ANSI C63.19-2011)

DASY5 Configuration:

- Probe: EX3DV4 - SN3979; ConvF(4.42, 4.42, 4.42); Calibrated: 2022/11/23;
- Sensor-Surface: 1.4mm (Mechanical Surface Detection)
- Electronics: DAE4 Sn1425; Calibrated: 2022/11/23
- Phantom: SAM with right table; Type: SAM;
- Measurement SW: DASYS52, Version 52.10 (0); SEMCAD X Version 14.6.10 (7417)

Configuration/Head/Area Scan (11x21x1): Measurement grid: dx=10mm, dy=10mm
Maximum value of SAR (measured) = 1.86 W/kg**Configuration/Head/Zoom Scan (7x7x7)/Cube 0:** Measurement grid: dx=4mm, dy=4mm, dz=1.4mm

Reference Value = 23.81 V/m; Power Drift = -0.01 dB

Peak SAR (extrapolated) = 4.32 W/kg

SAR(1 g) = 1.07 W/kg; SAR(10 g) = 0.354 W/kg

Maximum value of SAR (measured) = 2.56 W/kg

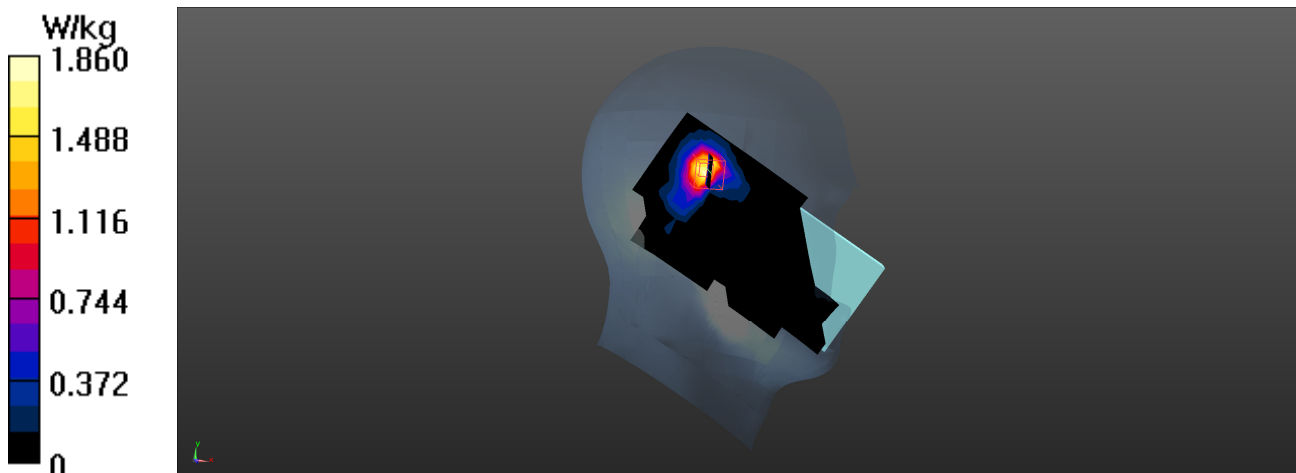

802.11ac80M EUT Left-Cheek_0mm_Head (Main Antenna), Z-Axis plot

Channel: 138

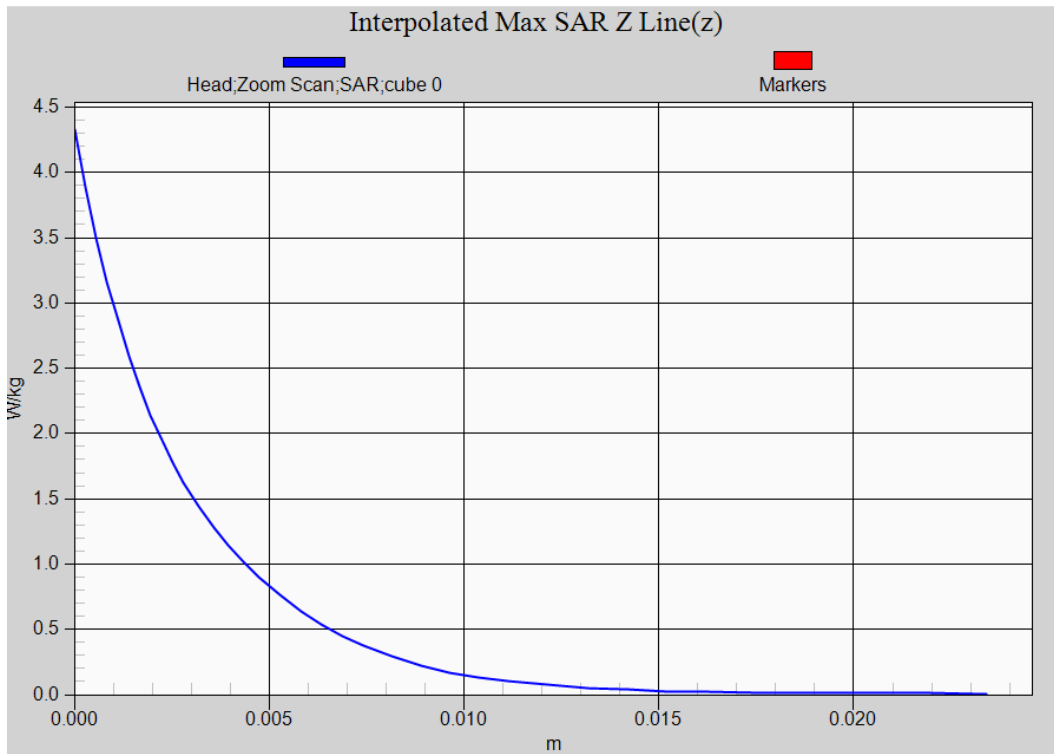

Test Laboratory: DEKRA

Date: 2022/12/10

08_802.11ac80M_138_Back Main_10mm**DUT: Mobile Computer; Type: RS36**

Communication System: UID 0, WLAN 5G; Frequency: 5690 MHz;

Communication System PAR: 0 dB

Medium parameters used: $f = 5690$ MHz; $\sigma = 5.17$ S/m; $\epsilon_r = 34.75$; $\rho = 1000$ kg/m³

Phantom section: Flat Section

Ambient Temperature (°C) : 22.8, Liquid Temperature (°C) : 21.8

Measurement Standard: DASYS (IEEE/IEC/ANSI C63.19-2011)

DASY5 Configuration:

- Probe: EX3DV4 - SN3979; ConvF(4.42, 4.42, 4.42); Calibrated: 2022/11/23;
- Sensor-Surface: 1.4mm (Mechanical Surface Detection)
- Electronics: DAE4 Sn1425; Calibrated: 2022/11/23
- Phantom: SAM with right table; Type: SAM;
- Measurement SW: DASYS2, Version 52.10 (0); SEMCAD X Version 14.6.10 (7417)

Configuration/Flat/Area Scan (12x20x1): Measurement grid: dx=10mm, dy=10mm

Maximum value of SAR (measured) = 0.768 W/kg

Configuration/Flat/Zoom Scan (7x7x7)/Cube 0: Measurement grid: dx=4mm, dy=4mm, dz=1.4mm

Reference Value = 12.95 V/m; Power Drift = -0.14 dB

Peak SAR (extrapolated) = 1.30 W/kg

SAR(1 g) = 0.333 W/kg; SAR(10 g) = 0.130 W/kg

Maximum value of SAR (measured) = 0.767 W/kg

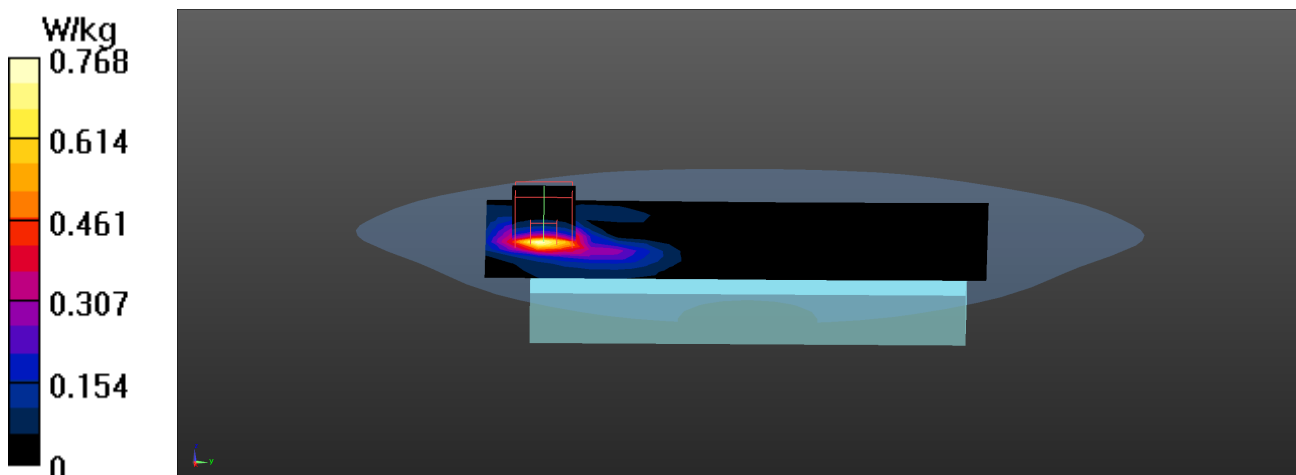

802.11ac80M EUT Back_10mm_Body (Main Antenna), Z-Axis plot

Channel: 138

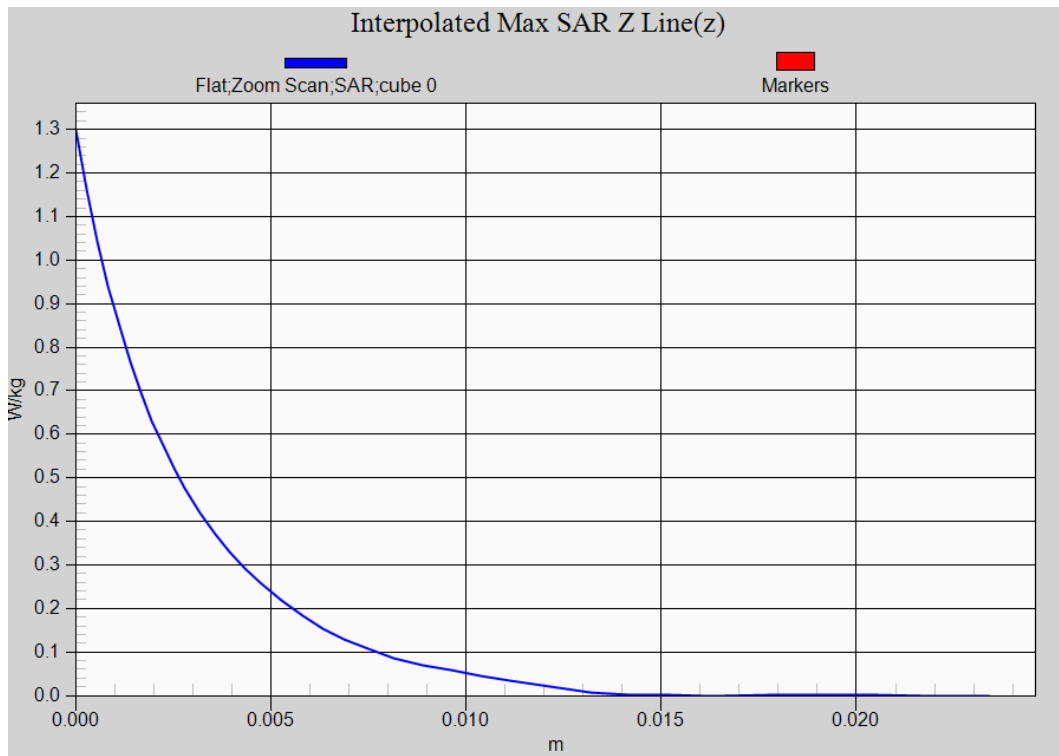

Test Laboratory: DEKRA

Date: 2022/12/10

09_802.11ac80M_122_Top Main 0mm**DUT: Mobile Computer; Type: RS36**

Communication System: UID 0, WLAN 5G; Frequency: 5610 MHz;

Communication System PAR: 0 dB

Medium parameters used: $f = 5610$ MHz; $\sigma = 5.07$ S/m; $\epsilon_r = 34.96$; $\rho = 1000$ kg/m³

Phantom section: Flat Section

Ambient Temperature (°C) : 22.8, Liquid Temperature (°C) : 21.8

Measurement Standard: DASYS5 (IEEE/IEC/ANSI C63.19-2011)

DASY5 Configuration:

- Probe: EX3DV4 - SN3979; ConvF(4.42, 4.42, 4.42); Calibrated: 2022/11/23;
- Sensor-Surface: 1.4mm (Mechanical Surface Detection)
- Electronics: DAE4 Sn1425; Calibrated: 2022/11/23
- Phantom: SAM with right table; Type: SAM;
- Measurement SW: DASYS52, Version 52.10 (0); SEMCAD X Version 14.6.10 (7417)

Configuration/Flat/Area Scan (7x13x1): Measurement grid: dx=10mm, dy=10mm

Maximum value of SAR (measured) = 5.45 W/kg

Configuration/Flat/Zoom Scan (7x7x7)/Cube 0: Measurement grid: dx=4mm, dy=4mm, dz=1.4mm

Reference Value = 42.05 V/m; Power Drift = 0.04 dB

Peak SAR (extrapolated) = 13.9 W/kg

SAR(1 g) = 2.61 W/kg; SAR(10 g) = 0.671 W/kg

Maximum value of SAR (measured) = 7.45 W/kg

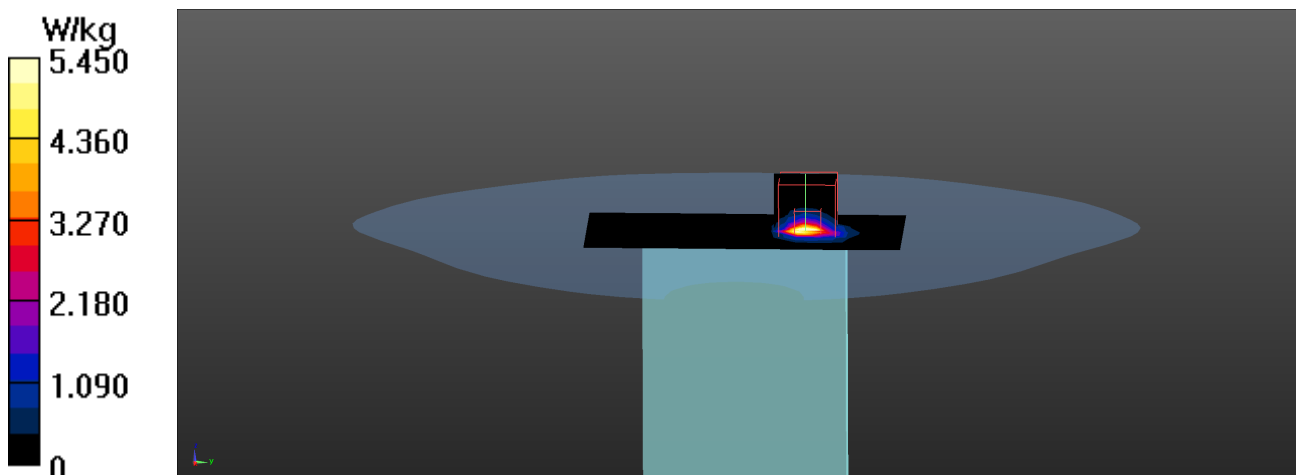

802.11ac80M EUT Top_0mm_Body (Main Antenna), Z-Axis plot

Channel: 122

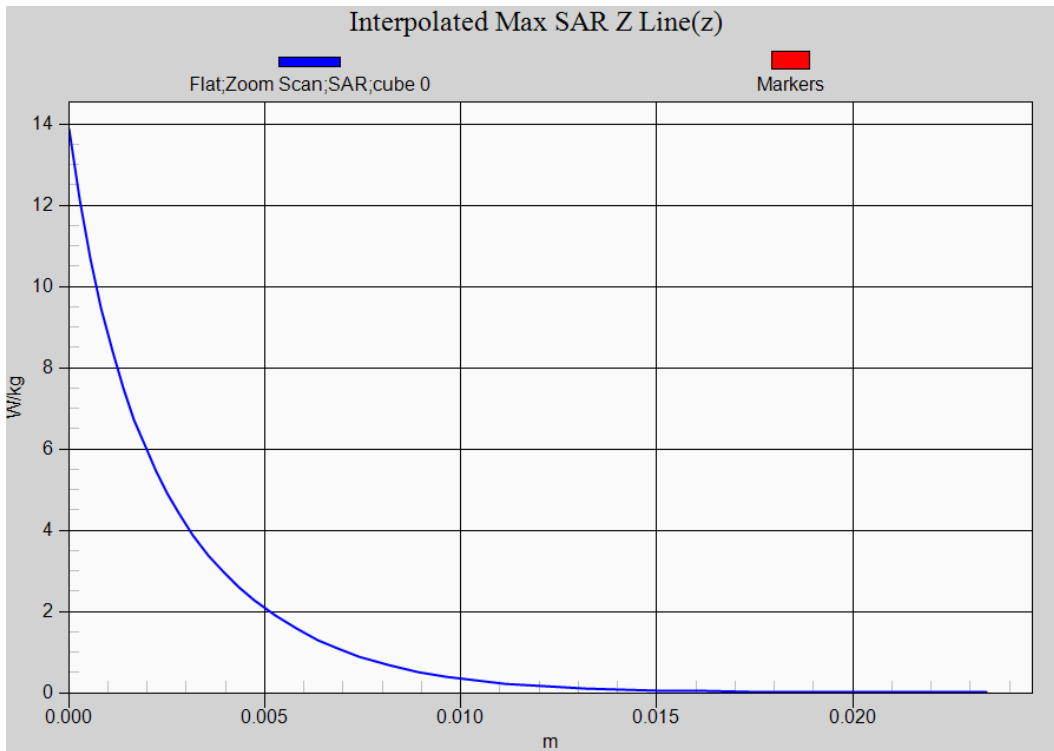

Test Laboratory: DEKRA

Date: 2022/12/27

10_GSM 850_4UP_Right-Cheek_128**DUT: Mobile Computer; Type: RS36**

Communication System: UID 0, FCC GSM_850MHz_GPRS&EGPRS-4 Slot;

Frequency: 824.2 MHz; Communication System PAR: 3.01 dB

Medium parameters used: $f = 824.2$ MHz; $\sigma = 0.89$ S/m; $\epsilon_r = 40.95$; $\rho = 1000$ kg/m³

Phantom section: Right Section

Ambient Temperature (°C) : 23.1, Liquid Temperature (°C) : 22.2

Measurement Standard: DASYS5 (IEEE/IEC/ANSI C63.19-2011)

DASY5 Configuration:

- Probe: EX3DV4 - SN3979; ConvF(10.05, 10.05, 10.05); Calibrated: 2022/11/23;
- Sensor-Surface: 1.4mm (Mechanical Surface Detection)
- Electronics: DAE4 Sn1425; Calibrated: 2022/11/23
- Phantom: SAM with right table; Type: SAM;
- Measurement SW: DASYS52, Version 52.10 (0); SEMCAD X Version 14.6.10 (7417)

Configuration/Head/Area Scan (8x14x1): Measurement grid: dx=15mm, dy=15mm

Maximum value of SAR (measured) = 0.956 W/kg

Configuration/Head/Zoom Scan (5x5x7)/Cube 0: Measurement grid: dx=8mm, dy=8mm, dz=5mm

Reference Value = 13.98 V/m; Power Drift = -0.13 dB

Peak SAR (extrapolated) = 1.04 W/kg

SAR(1 g) = 0.819 W/kg; SAR(10 g) = 0.626 W/kg

Maximum value of SAR (measured) = 0.966 W/kg

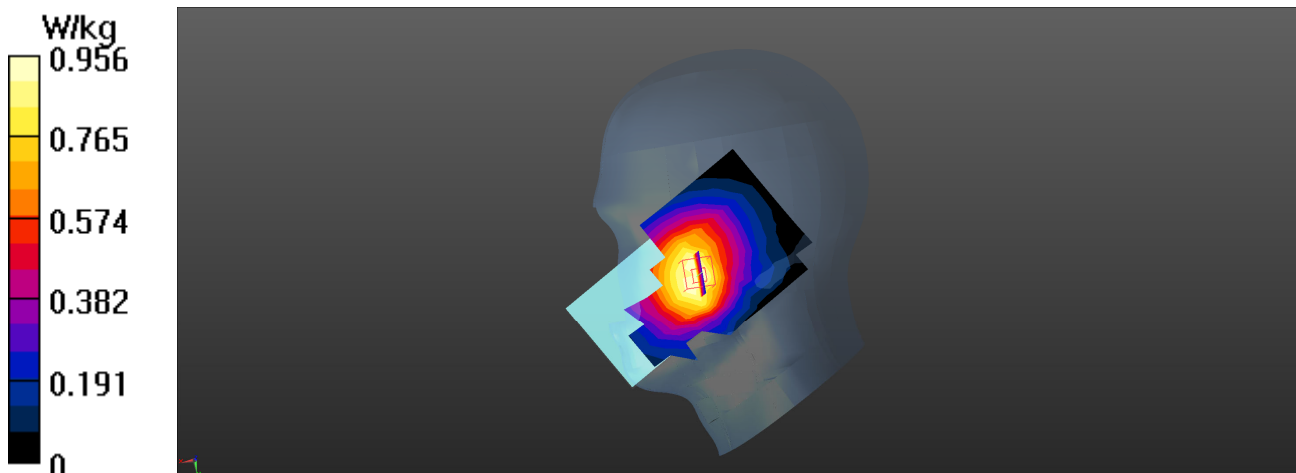

GSM 850 GPRS 4UP EUT Right-Cheek_0mm_Head, Z-Axis plot

Channel: 128

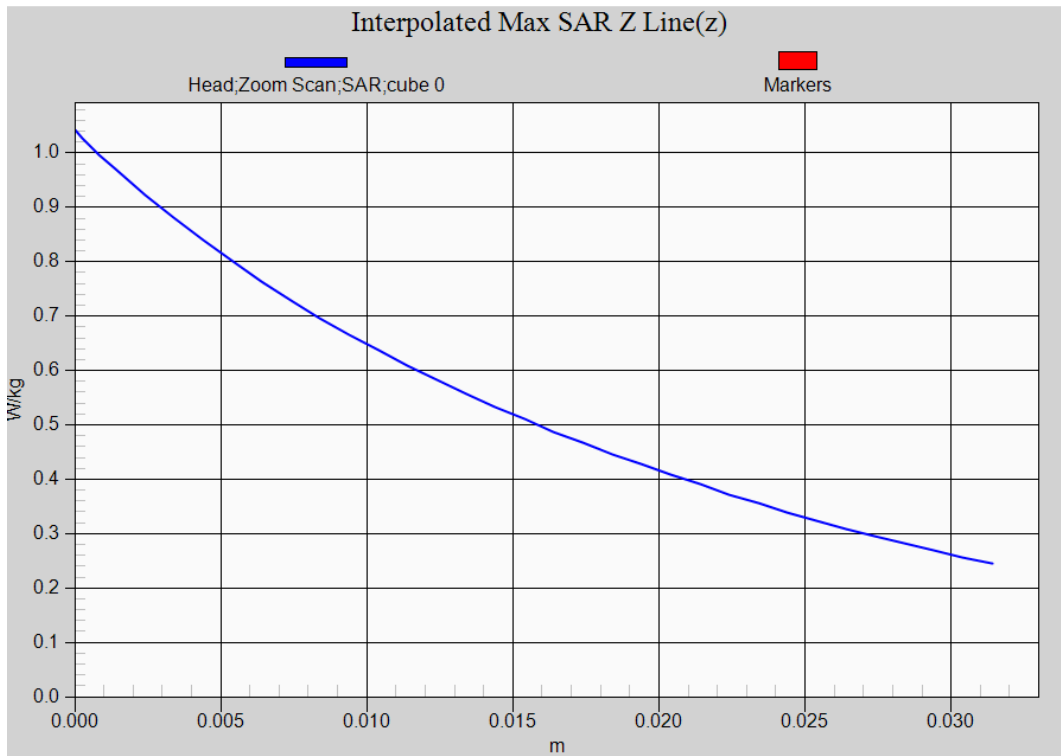

Test Laboratory: DEKRA

Date: 2022/12/27

11_GSM 850_4UP_Front_128_10mm**DUT: Mobile Computer; Type: RS36**

Communication System: UID 0, FCC GSM_850MHz_GPRS&EGPRS-4 Slot;

Frequency: 824.2 MHz; Communication System PAR: 3.01 dB

Medium parameters used: $f = 824.2$ MHz; $\sigma = 0.89$ S/m; $\epsilon_r = 40.95$; $\rho = 1000$ kg/m³

Phantom section: Flat Section

Ambient Temperature (°C) : 23.1, Liquid Temperature (°C) : 22.2

Measurement Standard: DASYS5 (IEEE/IEC/ANSI C63.19-2011)

DASY5 Configuration:

- Probe: EX3DV4 - SN3979; ConvF(10.05, 10.05, 10.05); Calibrated: 2022/11/23;
- Sensor-Surface: 1.4mm (Mechanical Surface Detection)
- Electronics: DAE4 Sn1425; Calibrated: 2022/11/23
- Phantom: SAM with right table; Type: SAM;
- Measurement SW: DASYS52, Version 52.10 (0); SEMCAD X Version 14.6.10 (7417)

Configuration/Flat/Area Scan (8x14x1): Measurement grid: dx=15mm, dy=15mm

Maximum value of SAR (measured) = 0.979 W/kg

Configuration/Flat/Zoom Scan (5x5x7)/Cube 0: Measurement grid: dx=8mm, dy=8mm, dz=5mm

Reference Value = 34.92 V/m; Power Drift = -0.07 dB

Peak SAR (extrapolated) = 1.09 W/kg

SAR(1 g) = 0.836 W/kg; SAR(10 g) = 0.633 W/kg

Maximum value of SAR (measured) = 1.00 W/kg

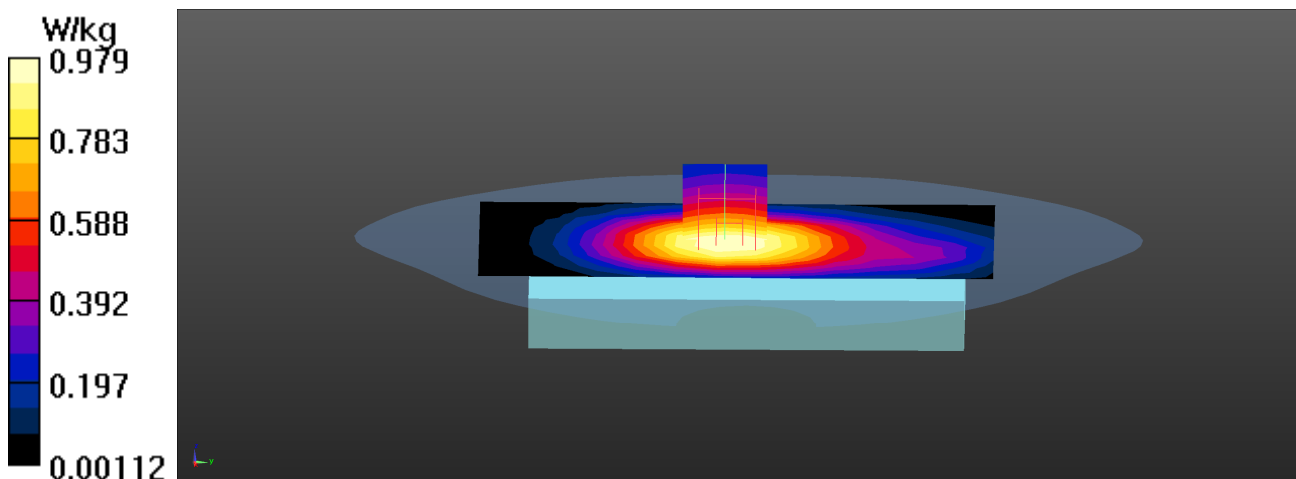

GSM 850 GPRS 4UP EUT Front_10mm_Body, Z-Axis plot

Channel: 128

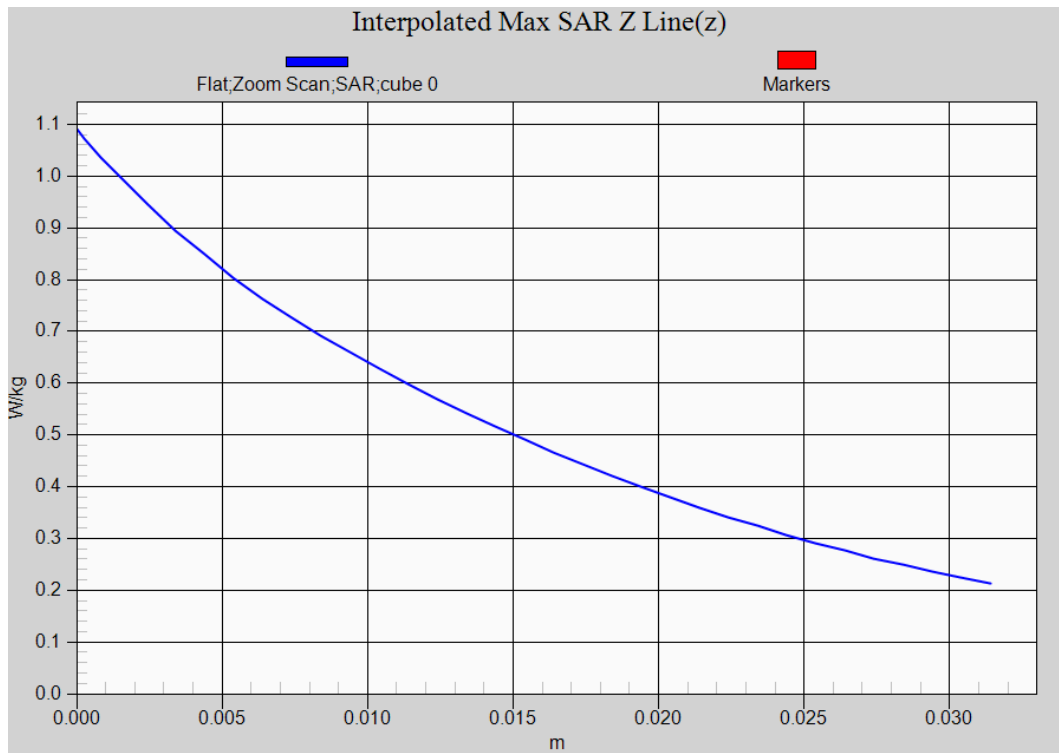

Test Laboratory: DEKRA

Date: 2022/12/27

12_PCS 1900_4UP_Left-Cheek_810**DUT: Mobile Computer; Type: RS36**

Communication System: UID 0, FCC PCS_1900MHz_GPRS&EGPRS-4 Slot;

Frequency: 1909.8 MHz; Communication System PAR: 3.01 dB

Medium parameters used: $f = 1909.8$ MHz; $\sigma = 1.41$ S/m; $\epsilon_r = 38.96$; $\rho = 1000$ kg/m³

Phantom section: Left Section

Ambient Temperature (°C) : 23.1, Liquid Temperature (°C) : 22.2

Measurement Standard: DASYS (IEEE/IEC/ANSI C63.19-2011)

DASY5 Configuration:

- Probe: EX3DV4 - SN3979; ConvF(8.12, 8.12, 8.12); Calibrated: 2022/11/23;
- Sensor-Surface: 1.4mm (Mechanical Surface Detection)
- Electronics: DAE4 Sn1425; Calibrated: 2022/11/23
- Phantom: SAM with right table; Type: SAM;
- Measurement SW: DASY52, Version 52.10 (0); SEMCAD X Version 14.6.10 (7417)

Configuration/Head/Area Scan (8x14x1): Measurement grid: dx=15mm, dy=15mm

Maximum value of SAR (measured) = 0.866 W/kg

Configuration/Head/Zoom Scan (5x5x7)/Cube 0: Measurement grid: dx=8mm, dy=8mm, dz=5mm

Reference Value = 4.269 V/m; Power Drift = 0.18 dB

Peak SAR (extrapolated) = 0.918 W/kg

SAR(1 g) = 0.594 W/kg; SAR(10 g) = 0.367 W/kg

Maximum value of SAR (measured) = 0.808 W/kg

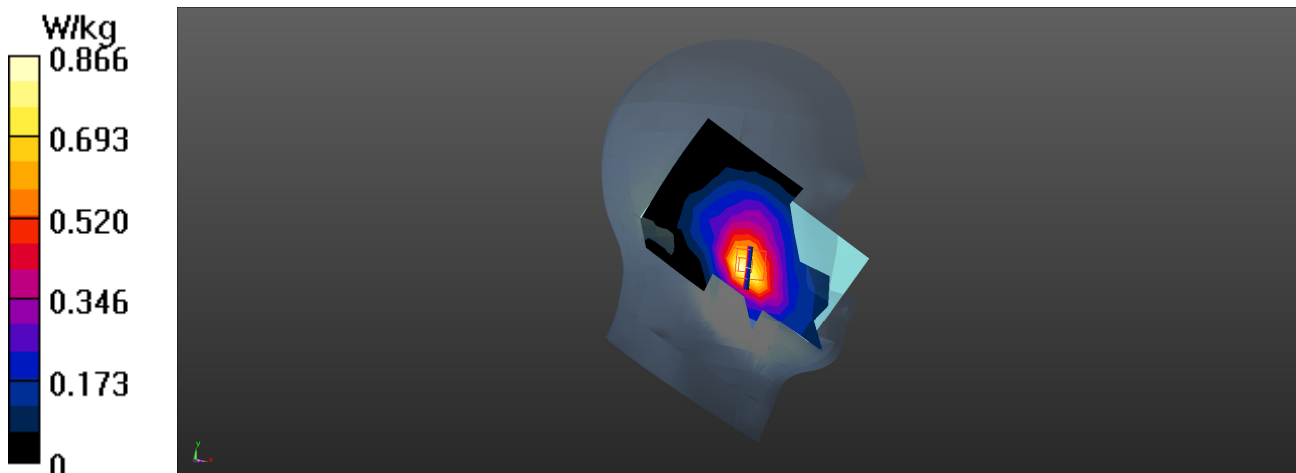

PCS 1900 GPRS 4UP EUT Left-Cheek_0mm_Head, Z-Axis plot

Channel: 661

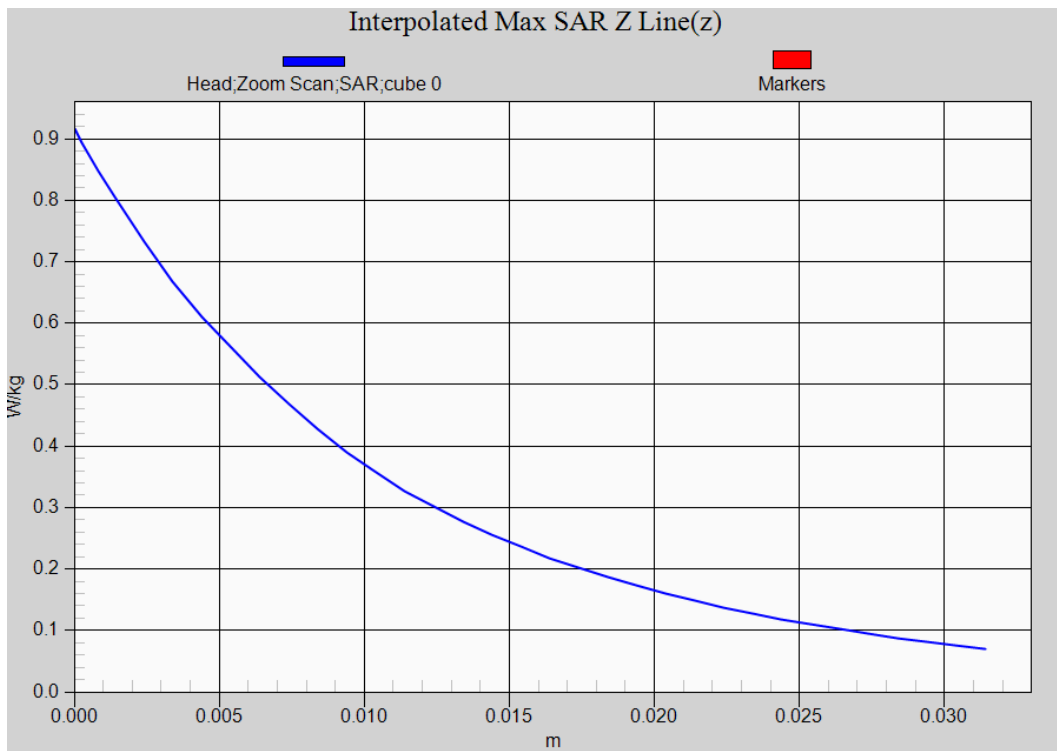

Test Laboratory: DEKRA

Date: 2022/12/27

13_PCS 1900_4UP_Back_512_10mm**DUT: Mobile Computer; Type: RS36**

Communication System: UID 0, FCC PCS_1900MHz_GPRS&EGPRS-4 Slot;

Frequency: 1850.2 MHz; Communication System PAR: 3.01 dB

Medium parameters used: $f = 1850.2$ MHz; $\sigma = 1.4$ S/m; $\epsilon_r = 39.11$; $\rho = 1000$ kg/m³

Phantom section: Flat Section

Ambient Temperature (°C) : 23.1, Liquid Temperature (°C) : 22.2

Measurement Standard: DASY5 (IEEE/IEC/ANSI C63.19-2011)

DASY5 Configuration:

- Probe: EX3DV4 - SN3979; ConvF(8.12, 8.12, 8.12); Calibrated: 2022/11/23;
- Sensor-Surface: 1.4mm (Mechanical Surface Detection)
- Electronics: DAE4 Sn1425; Calibrated: 2022/11/23
- Phantom: SAM with right table; Type: SAM;
- Measurement SW: DASY52, Version 52.10 (0); SEMCAD X Version 14.6.10 (7417)

Configuration/Flat/Area Scan (8x14x1): Measurement grid: dx=15mm, dy=15mm

Maximum value of SAR (measured) = 1.00 W/kg

Configuration/Flat/Zoom Scan (5x5x7)/Cube 0: Measurement grid: dx=8mm, dy=8mm, dz=5mm

Reference Value = 30.99 V/m; Power Drift = -0.14 dB

Peak SAR (extrapolated) = 1.78 W/kg

SAR(1 g) = 1.000 W/kg; SAR(10 g) = 0.496 W/kg

Maximum value of SAR (measured) = 1.36 W/kg

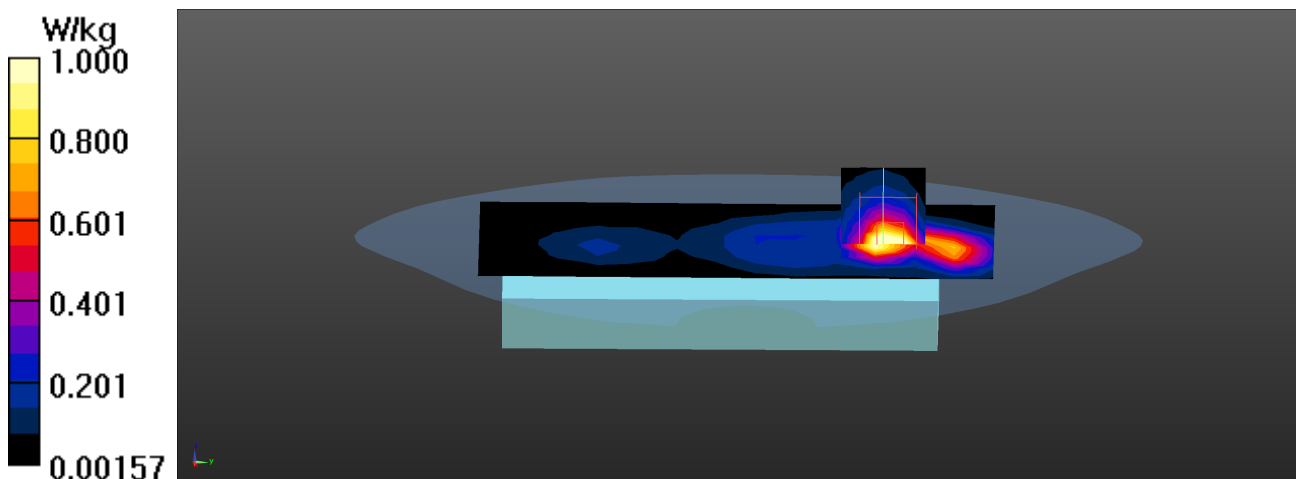

PCS 1900 GPRS 4UP EUT Back_10mm_Body, Z-Axis plot

Channel: 512

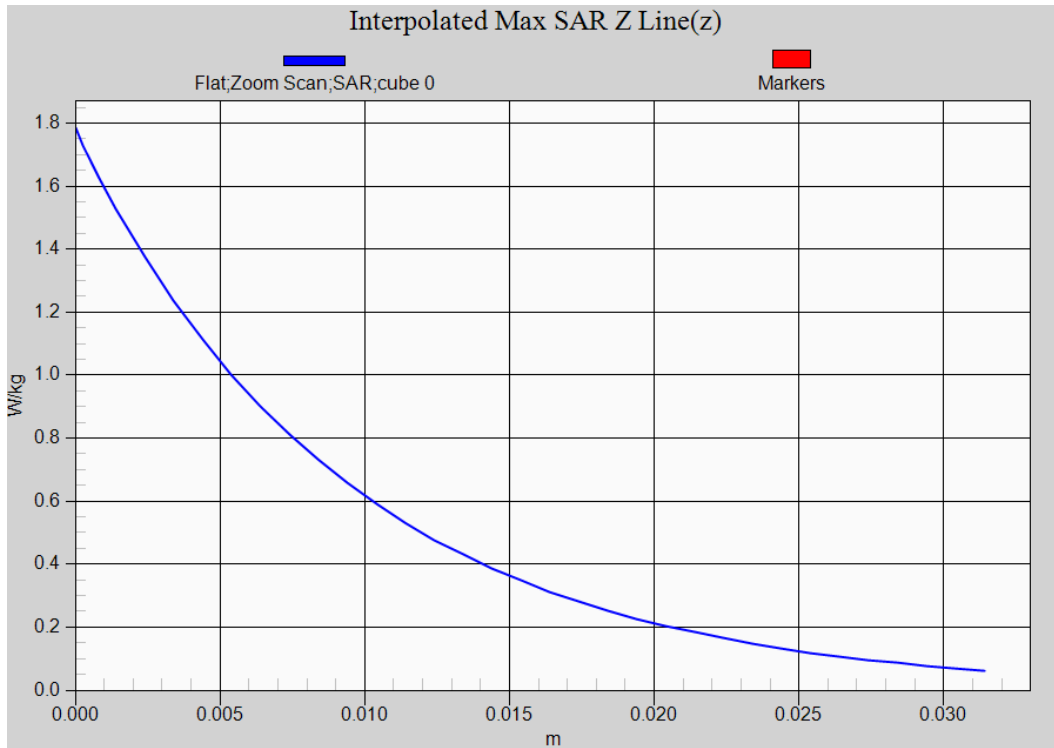

Test Laboratory: DEKRA

Date: 2022/12/17

14_WCDMA_BAND 2_RMC_9538_Left-Check**DUT: Mobile Computer; Type: RS36**

Communication System: UID 0, FCC WCDMA_Band-2; Frequency: 1907.6 MHz;

Communication System PAR: 0 dB

Medium parameters used: $f = 1907.6$ MHz; $\sigma = 1.38$ S/m; $\epsilon_r = 39.94$; $\rho = 1000$ kg/m³

Phantom section: Left Section

Ambient Temperature (°C) : 23.1, Liquid Temperature (°C) : 22.2

Measurement Standard: DASYS5 (IEEE/IEC/ANSI C63.19-2011)

DASY5 Configuration:

- Probe: EX3DV4 - SN3979; ConvF(8.12, 8.12, 8.12); Calibrated: 2022/11/23;
- Sensor-Surface: 1.4mm (Mechanical Surface Detection)
- Electronics: DAE4 Sn1425; Calibrated: 2022/11/23
- Phantom: SAM with right table; Type: SAM;
- Measurement SW: DASYS52, Version 52.10 (0); SEMCAD X Version 14.6.10 (7417)

Configuration/Head/Area Scan (8x14x1): Measurement grid: dx=15mm, dy=15mm

Maximum value of SAR (measured) = 0.653 W/kg

Configuration/Head/Zoom Scan (5x5x7)/Cube 0: Measurement grid: dx=8mm, dy=8mm, dz=5mm

Reference Value = 6.294 V/m; Power Drift = -0.03 dB

Peak SAR (extrapolated) = 0.705 W/kg

SAR(1 g) = 0.449 W/kg; SAR(10 g) = 0.276 W/kg

Maximum value of SAR (measured) = 0.610 W/kg

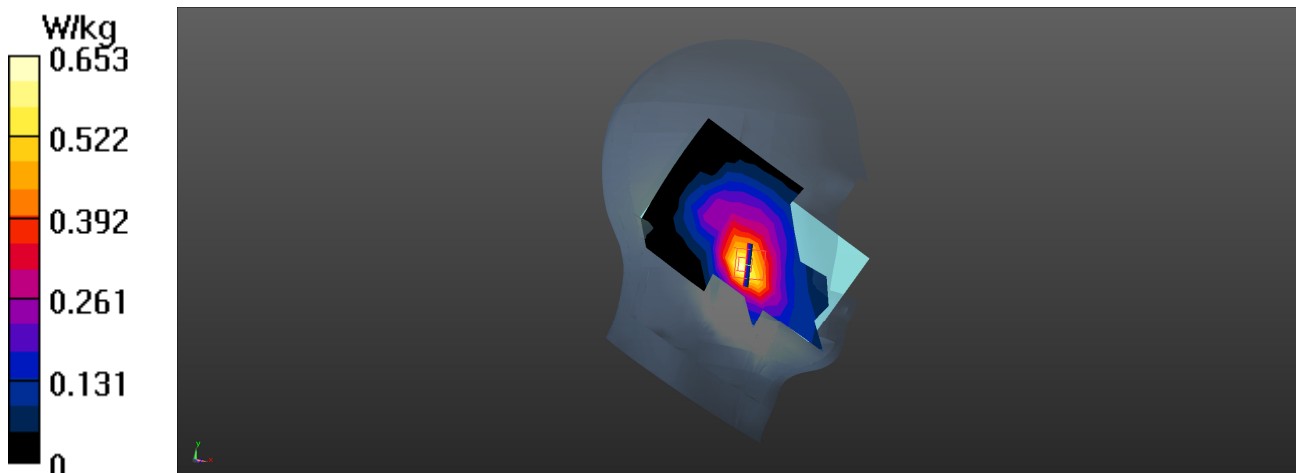

WCDMA_Band 2_RMC EUT Left-Check_0mm_Head, Z-Axis plot

Channel: 9538

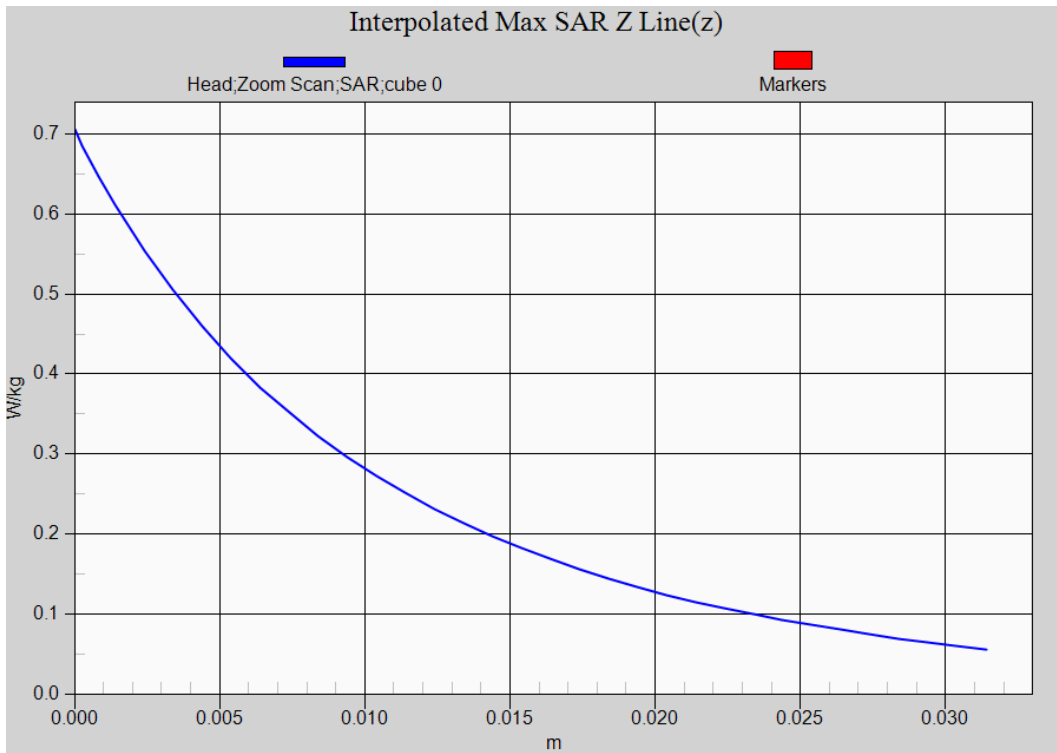

Test Laboratory: DEKRA

Date: 2022/12/17

15_WCDMA_BAND 2_RMC_9400_Back_10mm**DUT: Mobile Computer; Type: RS36**

Communication System: UID 0, FCC WCDMA_Band-2; Frequency: 1880 MHz;

Communication System PAR: 0 dB

Medium parameters used: $f = 1880$ MHz; $\sigma = 1.37$ S/m; $\epsilon_r = 40.21$; $\rho = 1000$ kg/m³

Phantom section: Flat Section

Ambient Temperature (°C) : 23.1, Liquid Temperature (°C) : 22.2

Measurement Standard: DASY5 (IEEE/IEC/ANSI C63.19-2011)

DASY5 Configuration:

- Probe: EX3DV4 - SN3979; ConvF(8.12, 8.12, 8.12); Calibrated: 2022/11/23;
- Sensor-Surface: 1.4mm (Mechanical Surface Detection)
- Electronics: DAE4 Sn1425; Calibrated: 2022/11/23
- Phantom: SAM with right table; Type: SAM;
- Measurement SW: DASY52, Version 52.10 (0); SEMCAD X Version 14.6.10 (7417)

Configuration/Flat/Area Scan (8x14x1): Measurement grid: dx=15mm, dy=15mm

Maximum value of SAR (measured) = 0.855 W/kg

Configuration/Flat/Zoom Scan (5x5x7)/Cube 0: Measurement grid: dx=8mm, dy=8mm, dz=5mm

Reference Value = 11.07 V/m; Power Drift = 0.06 dB

Peak SAR (extrapolated) = 1.02 W/kg

SAR(1 g) = 0.596 W/kg; SAR(10 g) = 0.318 W/kg

Maximum value of SAR (measured) = 0.853 W/kg

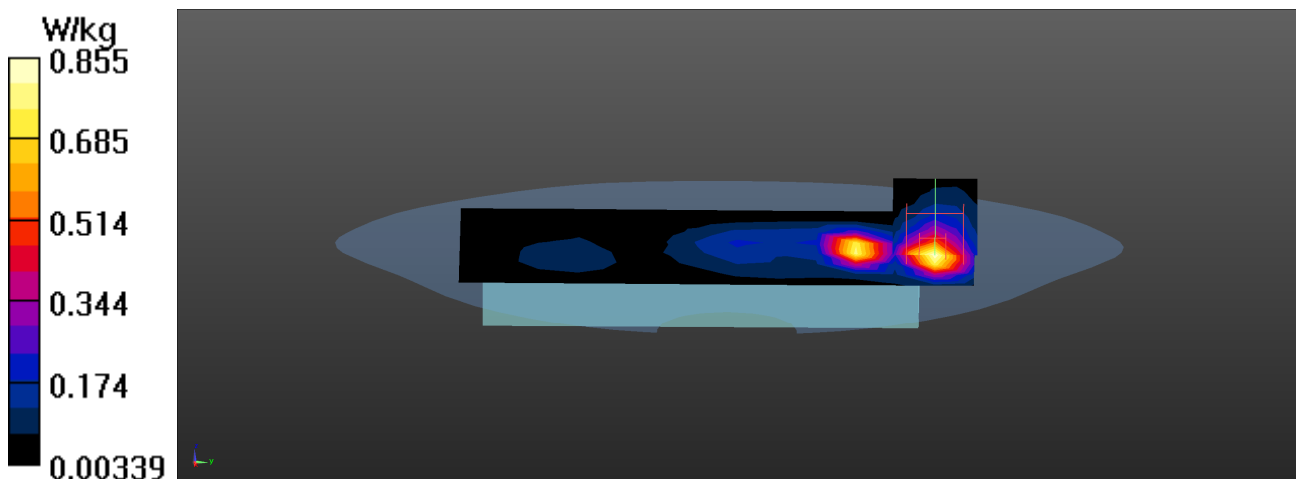

Test Laboratory: DEKRA

Date: 2022/12/17

16_WCDMA_BAND 2_RMC_9400_Bottom_10mm**DUT: Mobile Computer; Type: RS36**

Communication System: UID 0, FCC WCDMA_Band-2; Frequency: 1880 MHz;

Communication System PAR: 0 dB

Medium parameters used: $f = 1880$ MHz; $\sigma = 1.37$ S/m; $\epsilon_r = 40.21$; $\rho = 1000$ kg/m³

Phantom section: Flat Section

Ambient Temperature (°C) : 23.1, Liquid Temperature (°C) : 22.2

Measurement Standard: DASYS5 (IEEE/IEC/ANSI C63.19-2011)

DASY5 Configuration:

- Probe: EX3DV4 - SN3979; ConvF(8.12, 8.12, 8.12); Calibrated: 2022/11/23;
- Sensor-Surface: 1.4mm (Mechanical Surface Detection)
- Electronics: DAE4 Sn1425; Calibrated: 2022/11/23
- Phantom: SAM with right table; Type: SAM;
- Measurement SW: DASYS52, Version 52.10 (0); SEMCAD X Version 14.6.10 (7417)

Configuration/Flat/Area Scan (7x9x1): Measurement grid: dx=15mm, dy=15mm

Maximum value of SAR (measured) = 1.13 W/kg

Configuration/Flat/Zoom Scan (5x5x7)/Cube 0: Measurement grid: dx=8mm, dy=8mm, dz=5mm

Reference Value = 26.16 V/m; Power Drift = -0.02 dB

Peak SAR (extrapolated) = 1.49 W/kg

SAR(1 g) = 0.879 W/kg; SAR(10 g) = 0.485 W/kg

Maximum value of SAR (measured) = 1.28 W/kg

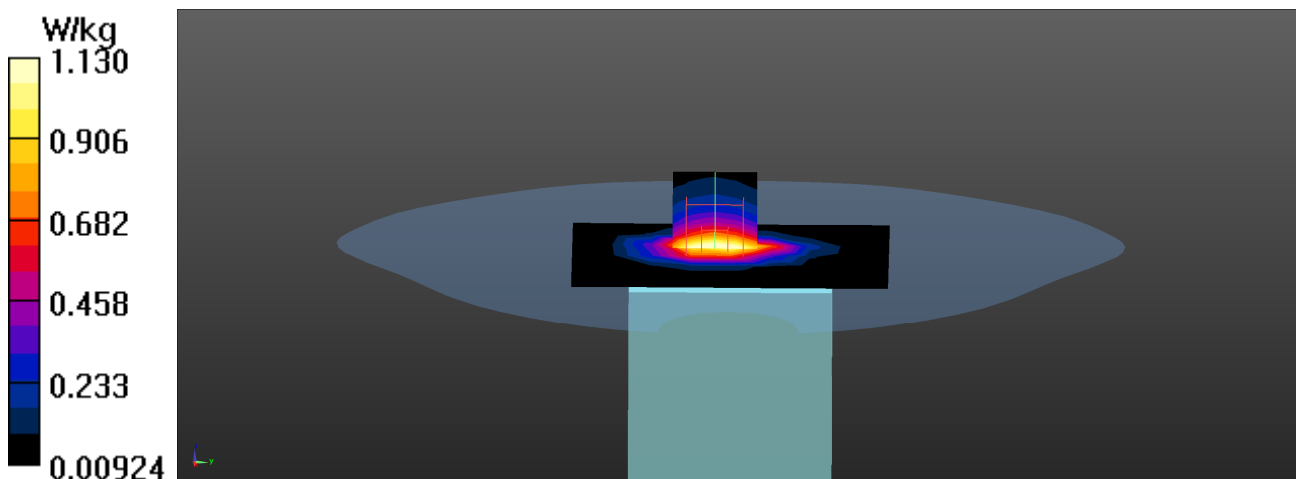

WCDMA_Band 2_RMC EUT Bottom_10mm_Body, Z-Axis plot

Channel: 9400

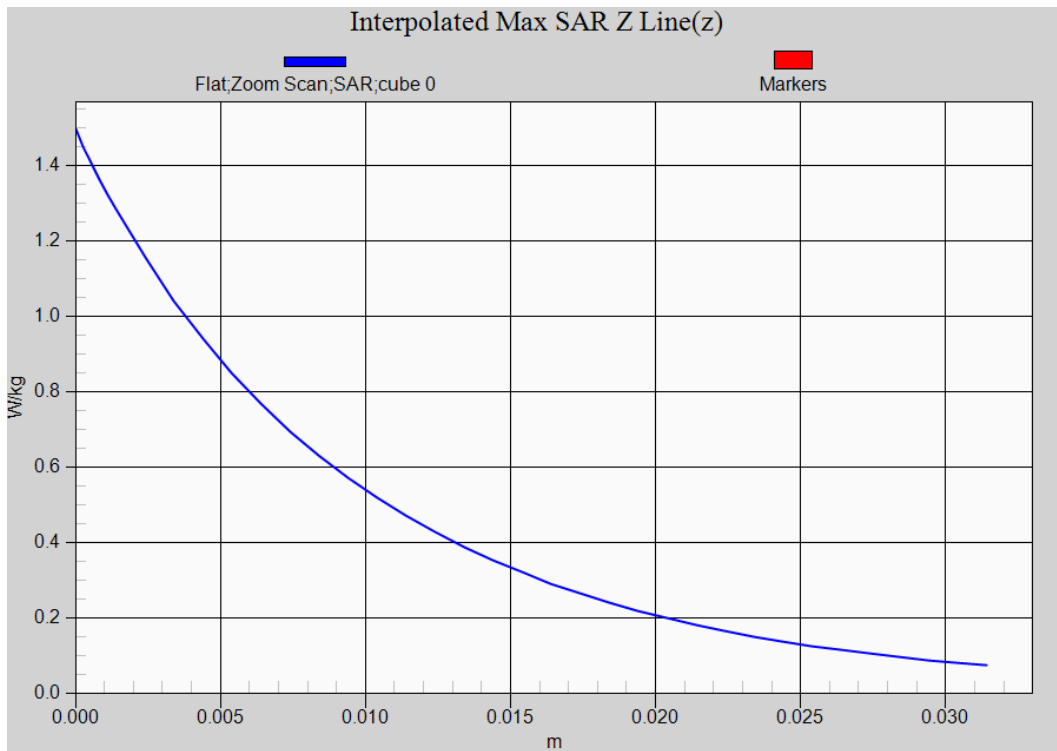

Test Laboratory: DEKRA

Date: 2022/12/27

17_WCDMA_BAND 4_RMC_1513_Left-Check**DUT: Mobile Computer; Type: RS36**

Communication System: UID 0, FCC WCDMA_Band 4; Frequency: 1752.6 MHz;

Communication System PAR: 0 dB

Medium parameters used: $f = 1752.6$ MHz; $\sigma = 1.38$ S/m; $\epsilon_r = 39.56$; $\rho = 1000$ kg/m³

Phantom section: Left Section

Ambient Temperature (°C) : 23.1, Liquid Temperature (°C) : 22.2

Measurement Standard: DASYS5 (IEEE/IEC/ANSI C63.19-2011)

DASY5 Configuration:

- Probe: EX3DV4 - SN3979; ConvF(8.34, 8.34, 8.34); Calibrated: 2022/11/23;
- Sensor-Surface: 1.4mm (Mechanical Surface Detection)
- Electronics: DAE4 Sn1425; Calibrated: 2022/11/23
- Phantom: SAM with right table; Type: SAM;
- Measurement SW: DASYS52, Version 52.10 (0); SEMCAD X Version 14.6.10 (7417)

Configuration/Head/Area Scan (8x14x1): Measurement grid: dx=15mm, dy=15mm

Maximum value of SAR (measured) = 0.317 W/kg

Configuration/Head/Zoom Scan (5x5x7)/Cube 0: Measurement grid: dx=8mm, dy=8mm, dz=5mm

Reference Value = 4.172 V/m; Power Drift = 0.01 dB

Peak SAR (extrapolated) = 0.359 W/kg

SAR(1 g) = 0.225 W/kg; SAR(10 g) = 0.135 W/kg

Maximum value of SAR (measured) = 0.305 W/kg

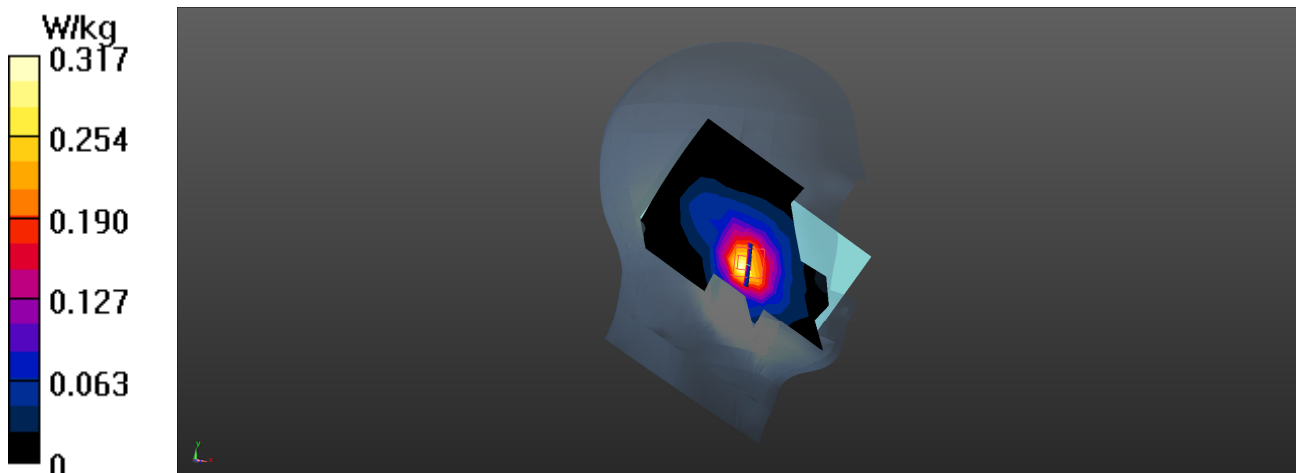

WCDMA_Band 4_RMC EUT Left-Check_0mm_Head, Z-Axis plot

Channel: 1513

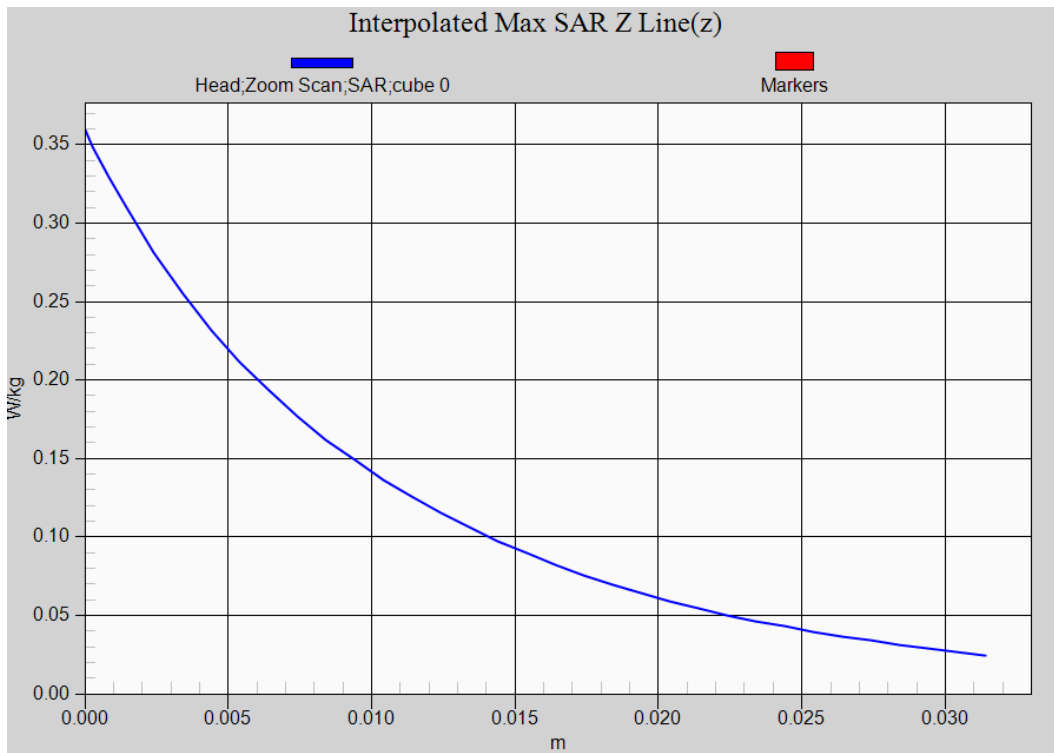

Test Laboratory: DEKRA

Date: 2022/12/27

18_WCDMA_BAND 4_RMC_1312_Back_10mm**DUT: Mobile Computer; Type: RS36**

Communication System: UID 0, FCC WCDMA_Band 4; Frequency: 1712.4 MHz;

Communication System PAR: 0 dB

Medium parameters used: $f = 1712.4$ MHz; $\sigma = 1.36$ S/m; $\epsilon_r = 39.93$; $\rho = 1000$ kg/m³

Phantom section: Flat Section

Ambient Temperature (°C) : 23.1, Liquid Temperature (°C) : 22.2

Measurement Standard: DASYS5 (IEEE/IEC/ANSI C63.19-2011)

DASY5 Configuration:

- Probe: EX3DV4 - SN3979; ConvF(8.34, 8.34, 8.34); Calibrated: 2022/11/23;
- Sensor-Surface: 1.4mm (Mechanical Surface Detection)
- Electronics: DAE4 Sn1425; Calibrated: 2022/11/23
- Phantom: SAM with right table; Type: SAM;
- Measurement SW: DASYS52, Version 52.10 (0); SEMCAD X Version 14.6.10 (7417)

Configuration/Head/Area Scan (8x15x1): Measurement grid: dx=15mm, dy=15mm

Maximum value of SAR (measured) = 1.42 W/kg

Configuration/Head/Zoom Scan (5x5x7)/Cube 0: Measurement grid: dx=8mm, dy=8mm, dz=5mm

Reference Value = 33.39 V/m; Power Drift = 0.01 dB

Peak SAR (extrapolated) = 1.68 W/kg

SAR(1 g) = 0.987 W/kg; SAR(10 g) = 0.562 W/kg

Maximum value of SAR (measured) = 1.57 W/kg

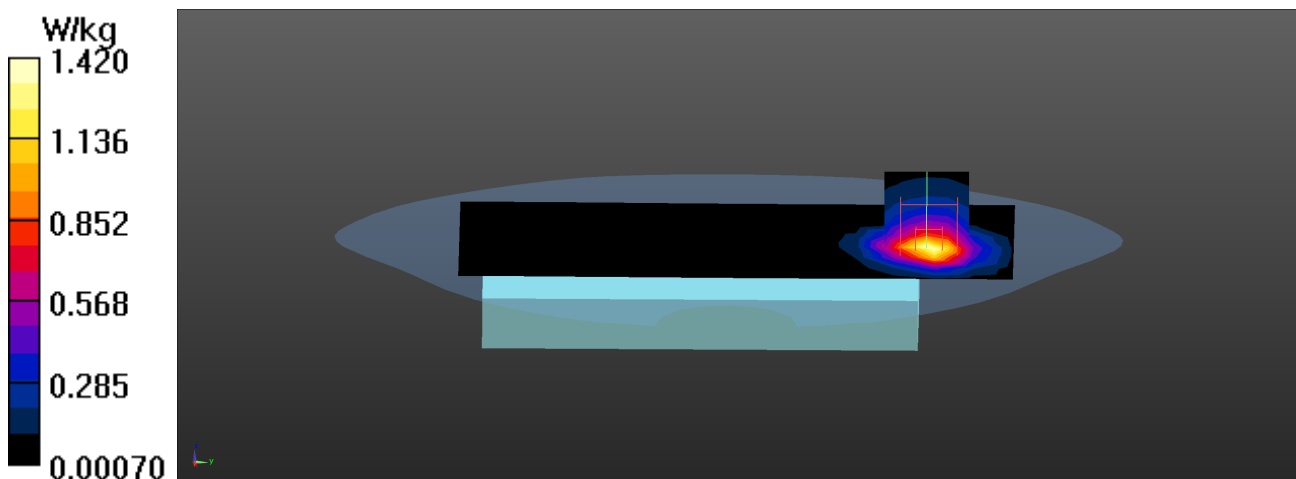

Test Laboratory: DEKRA

Date: 2022/12/27

19_WCDMA_BAND 4_RMC_1312_Bottom_10mm**DUT: Mobile Computer; Type: RS36**

Communication System: UID 0, FCC WCDMA_Band 4; Frequency: 1712.4 MHz;

Communication System PAR: 0 dB

Medium parameters used: $f = 1712.4$ MHz; $\sigma = 1.36$ S/m; $\epsilon_r = 39.93$; $\rho = 1000$ kg/m³

Phantom section: Flat Section

Ambient Temperature (°C) : 23.1, Liquid Temperature (°C) : 22.2

Measurement Standard: DASYS5 (IEEE/IEC/ANSI C63.19-2011)

DASY5 Configuration:

- Probe: EX3DV4 - SN3979; ConvF(8.34, 8.34, 8.34); Calibrated: 2022/11/23;
- Sensor-Surface: 1.4mm (Mechanical Surface Detection)
- Electronics: DAE4 Sn1425; Calibrated: 2022/11/23
- Phantom: SAM with right table; Type: SAM;
- Measurement SW: DASYS52, Version 52.10 (0); SEMCAD X Version 14.6.10 (7417)

Configuration/Head/Area Scan (8x11x1): Measurement grid: dx=15mm, dy=15mm

Maximum value of SAR (measured) = 1.24 W/kg

Configuration/Head/Zoom Scan (5x5x7)/Cube 0: Measurement grid: dx=8mm, dy=8mm, dz=5mm

Reference Value = 33.34 V/m; Power Drift = -0.05 dB

Peak SAR (extrapolated) = 1.81 W/kg

SAR(1 g) = 1.06 W/kg; SAR(10 g) = 0.597 W/kg

Maximum value of SAR (measured) = 1.54 W/kg

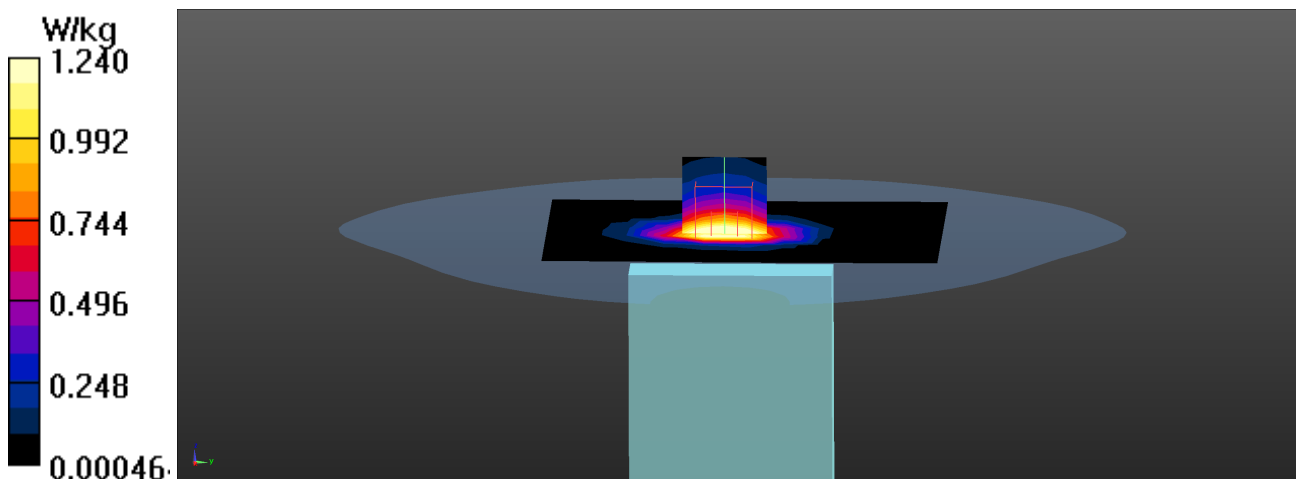

WCDMA_Band 4_RMC EUT Bottom_10mm_Body, Z-Axis plot

Channel: 1312

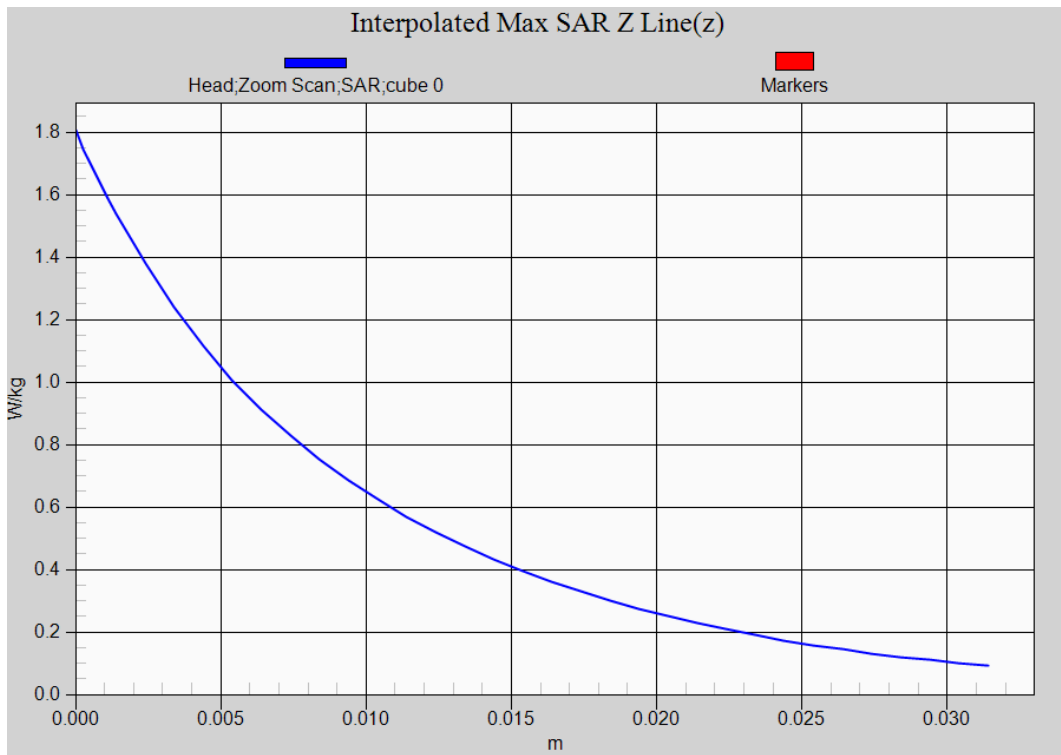

Test Laboratory: DEKRA

Date: 2022/12/18

20_WCDMA_BAND 5_RMC_4233_Right-Check**DUT: Mobile Computer; Type: RS36**

Communication System: UID 0, FCC WCDMA_Band-5; Frequency: 846.6 MHz;

Communication System PAR: 0 dB

Medium parameters used: $f = 846.6$ MHz; $\sigma = 0.92$ S/m; $\epsilon_r = 40.49$; $\rho = 1000$ kg/m³

Phantom section: Right Section

Ambient Temperature (°C) : 23.2, Liquid Temperature (°C) : 22.1

Measurement Standard: DASY5 (IEEE/IEC/ANSI C63.19-2011)

DASY5 Configuration:

- Probe: EX3DV4 - SN3979; ConvF(10.05, 10.05, 10.05); Calibrated: 2022/11/23;
- Sensor-Surface: 1.4mm (Mechanical Surface Detection)
- Electronics: DAE4 Sn1425; Calibrated: 2022/11/23
- Phantom: SAM with right table; Type: SAM;
- Measurement SW: DASY52, Version 52.10 (0); SEMCAD X Version 14.6.10 (7417)

Configuration/Head/Area Scan (8x14x1): Measurement grid: dx=15mm, dy=15mm

Maximum value of SAR (measured) = 0.348 W/kg

Configuration/Head/Zoom Scan (5x5x7)/Cube 0: Measurement grid: dx=8mm, dy=8mm, dz=5mm

Reference Value = 6.629 V/m; Power Drift = 0.06 dB

Peak SAR (extrapolated) = 0.402 W/kg

SAR(1 g) = 0.311 W/kg; SAR(10 g) = 0.235 W/kg

Maximum value of SAR (measured) = 0.367 W/kg

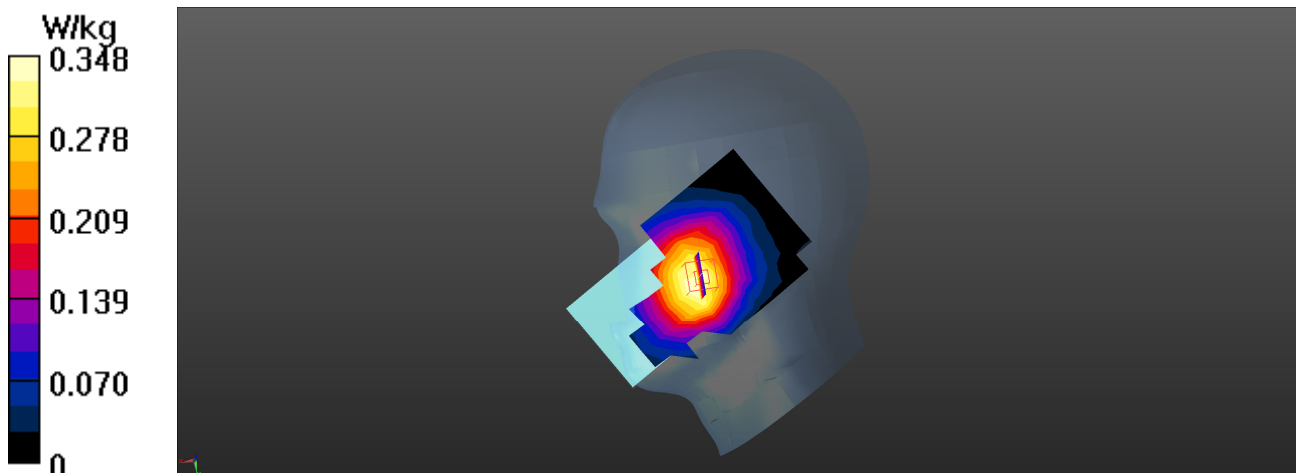

WCDMA_Band 5_RMC EUT Right-Check_0mm_Head, Z-Axis plot

Channel: 4233

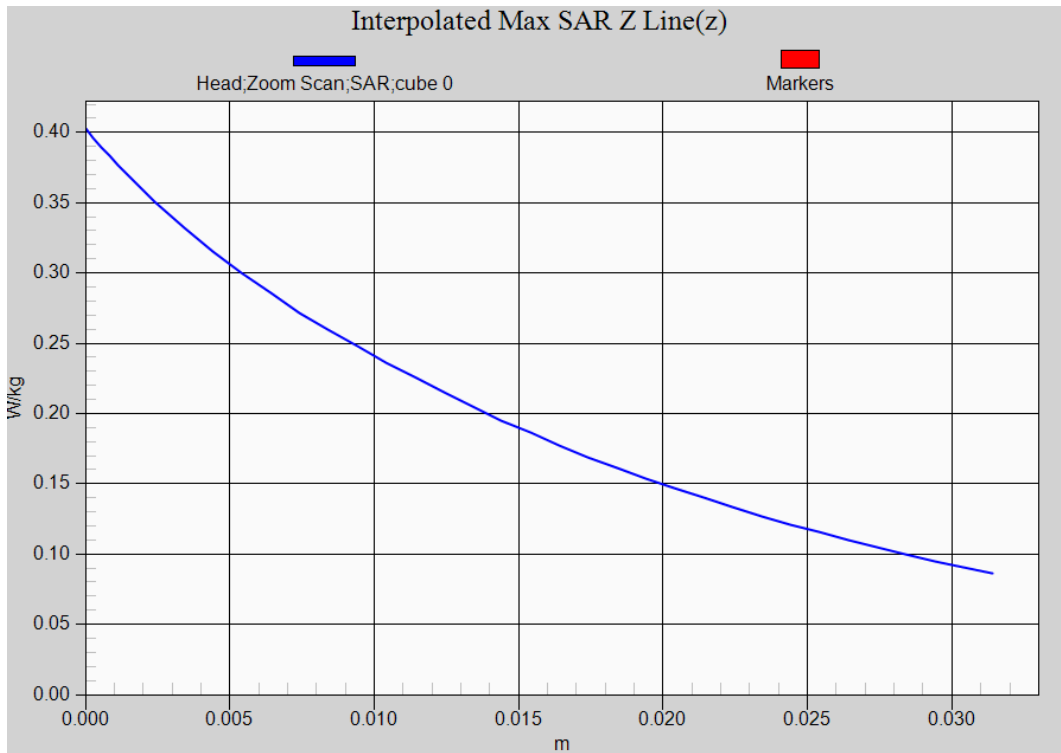

Test Laboratory: DEKRA

Date: 2022/12/18

21_WCDMA_BAND 5_RMC_4183_Front_10mm**DUT: Mobile Computer; Type: RS36**

Communication System: UID 0, FCC WCDMA_Band-5; Frequency: 836.6 MHz;

Communication System PAR: 0 dB

Medium parameters used: $f = 836.6$ MHz; $\sigma = 0.91$ S/m; $\epsilon_r = 40.62$; $\rho = 1000$ kg/m³

Phantom section: Flat Section

Ambient Temperature (°C) : 23.2, Liquid Temperature (°C) : 22.1

Measurement Standard: DASYS5 (IEEE/IEC/ANSI C63.19-2011)

DASY5 Configuration:

- Probe: EX3DV4 - SN3979; ConvF(10.05, 10.05, 10.05); Calibrated: 2022/11/23;
- Sensor-Surface: 1.4mm (Mechanical Surface Detection)
- Electronics: DAE4 Sn1425; Calibrated: 2022/11/23
- Phantom: SAM with right table; Type: SAM;
- Measurement SW: DASYS52, Version 52.10 (0); SEMCAD X Version 14.6.10 (7417)

Configuration/Flat/Area Scan (8x14x1): Measurement grid: dx=15mm, dy=15mm

Maximum value of SAR (measured) = 0.308 W/kg

Configuration/Flat/Zoom Scan (5x5x7)/Cube 0: Measurement grid: dx=8mm, dy=8mm, dz=5mm

Reference Value = 19.15 V/m; Power Drift = -0.01 dB

Peak SAR (extrapolated) = 0.332 W/kg

SAR(1 g) = 0.253 W/kg; SAR(10 g) = 0.190 W/kg

Maximum value of SAR (measured) = 0.305 W/kg

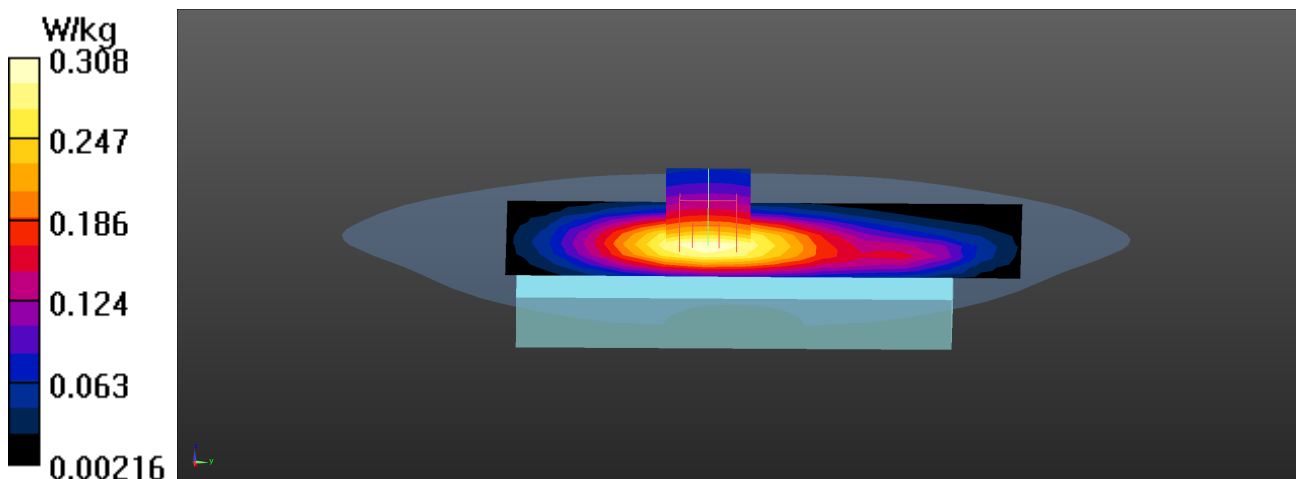

WCDMA_Band 5_RMC EUT Front_10mm_Body, Z-Axis plot

Channel: 4138

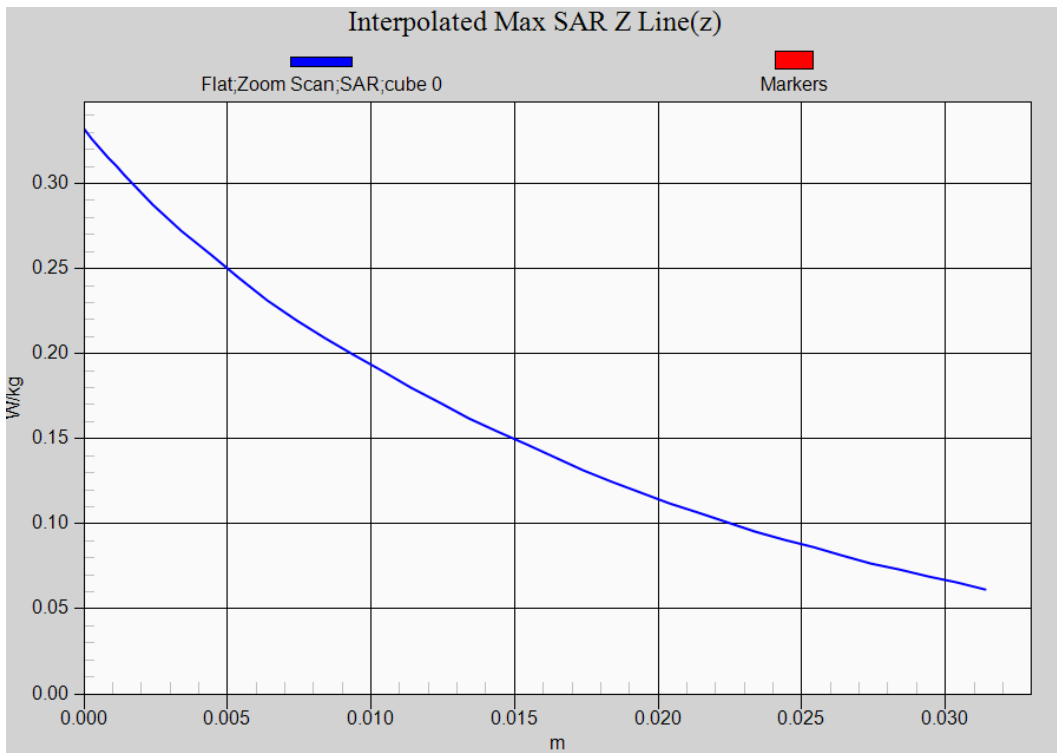

Test Laboratory: DEKRA

Date: 2022/12/17

22_LTE_Band7_QPSK_20M_20850_1RB-50_Left-Check**DUT: Mobile Computer; Type: RS36**

Communication System: UID 0, LTE Band7; Frequency: 2510 MHz;

Communication System PAR: 0 dB

Medium parameters used: $f = 2510$ MHz; $\sigma = 1.91$ S/m; $\epsilon_r = 38.97$; $\rho = 1000$ kg/m³

Phantom section: Left Section

Ambient Temperature (°C) : 22.8, Liquid Temperature (°C) : 21.7

Measurement Standard: DASYS (IEEE/IEC/ANSI C63.19-2011)

DASY5 Configuration:

- Probe: EX3DV4 - SN3979; ConvF(7.38, 7.38, 7.38); Calibrated: 2022/11/23;
- Sensor-Surface: 1.4mm (Mechanical Surface Detection)
- Electronics: DAE4 Sn1425; Calibrated: 2022/11/23
- Phantom: SAM with right table; Type: SAM;
- Measurement SW: DASYS2, Version 52.10 (0); SEMCAD X Version 14.6.10 (7417)

Configuration/Head/Area Scan (10x17x1): Measurement grid: dx=12mm, dy=12mm

Maximum value of SAR (measured) = 0.105 W/kg

Configuration/Head/Zoom Scan (7x7x7)/Cube 0: Measurement grid: dx=5mm, dy=5mm, dz=5mm

Reference Value = 4.250 V/m; Power Drift = -0.06 dB

Peak SAR (extrapolated) = 0.136 W/kg

SAR(1 g) = 0.070 W/kg; SAR(10 g) = 0.040 W/kg

Maximum value of SAR (measured) = 0.111 W/kg

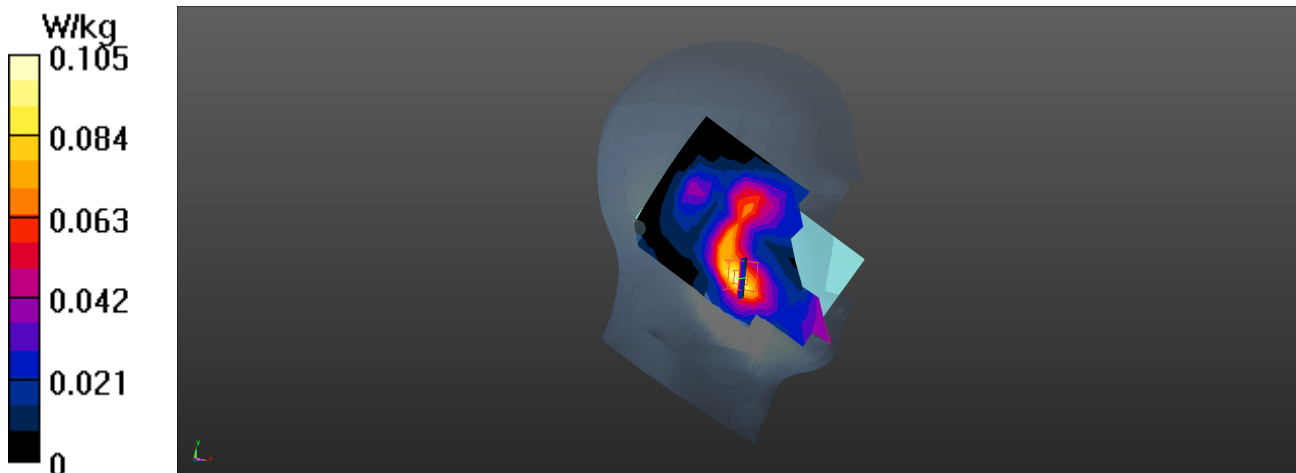

LTE Band 7 QPSK 20M EUT 1RB-50_Left-Check_0mm_Head, Z-Axis plot

Channel: 20850

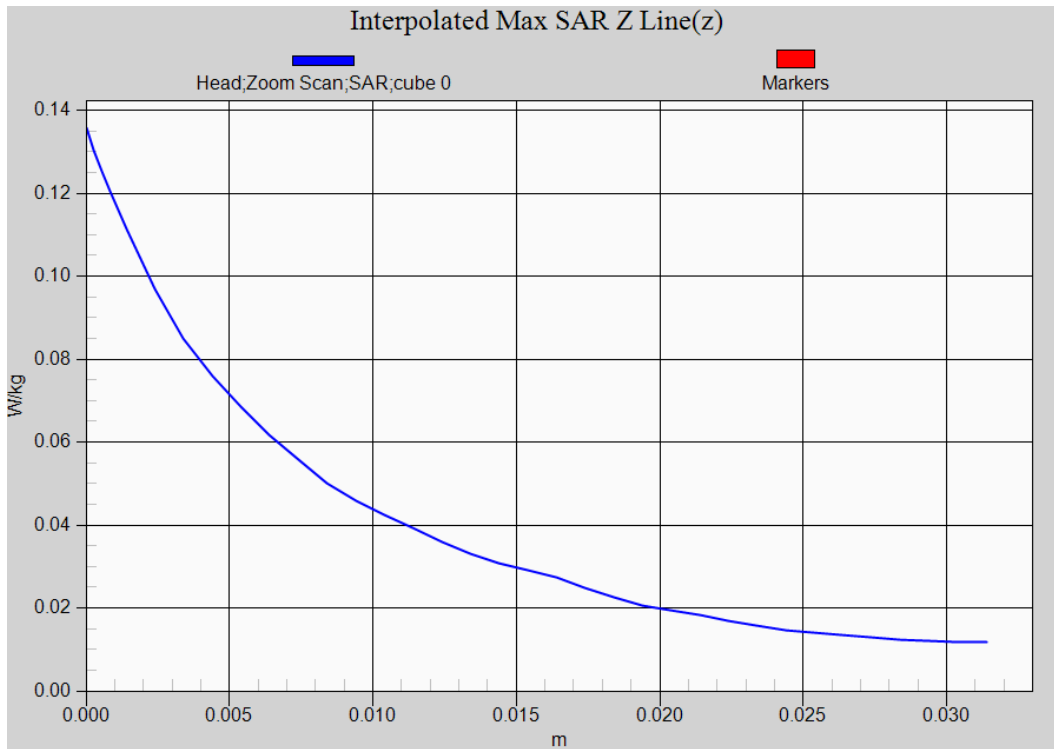

Test Laboratory: DEKRA

Date: 2022/12/17

23_LTE_Band7_QPSK_20M_21100_1RB-50_Back_10mm

DUT: Mobile Computer; Type: RS36

Communication System: UID 0, LTE Band7; Frequency: 2535 MHz;

Communication System PAR: 0 dB

Medium parameters used: $f = 2535$ MHz; $\sigma = 1.92$ S/m; $\epsilon_r = 38.67$; $\rho = 1000$ kg/m³

Phantom section: Flat Section

Ambient Temperature (°C) : 22.8, Liquid Temperature (°C) : 21.7

Measurement Standard: DASYS (IEEE/IEC/ANSI C63.19-2011)

DASY5 Configuration:

- Probe: EX3DV4 - SN3979; ConvF(7.38, 7.38, 7.38); Calibrated: 2022/11/23;
- Sensor-Surface: 1.4mm (Mechanical Surface Detection)
- Electronics: DAE4 Sn1425; Calibrated: 2022/11/23
- Phantom: SAM with right table; Type: SAM;
- Measurement SW: DASYS2, Version 52.10 (0); SEMCAD X Version 14.6.10 (7417)

Configuration/Flat/Area Scan (10x17x1): Measurement grid: dx=12mm, dy=12mm

Maximum value of SAR (measured) = 0.868 W/kg

Configuration/Flat/Zoom Scan (7x7x7)/Cube 0: Measurement grid: dx=5mm, dy=5mm, dz=5mm

Reference Value = 24.41 V/m; Power Drift = -0.08 dB

Peak SAR (extrapolated) = 1.18 W/kg

SAR(1 g) = 0.621 W/kg; SAR(10 g) = 0.314 W/kg

Maximum value of SAR (measured) = 0.974 W/kg

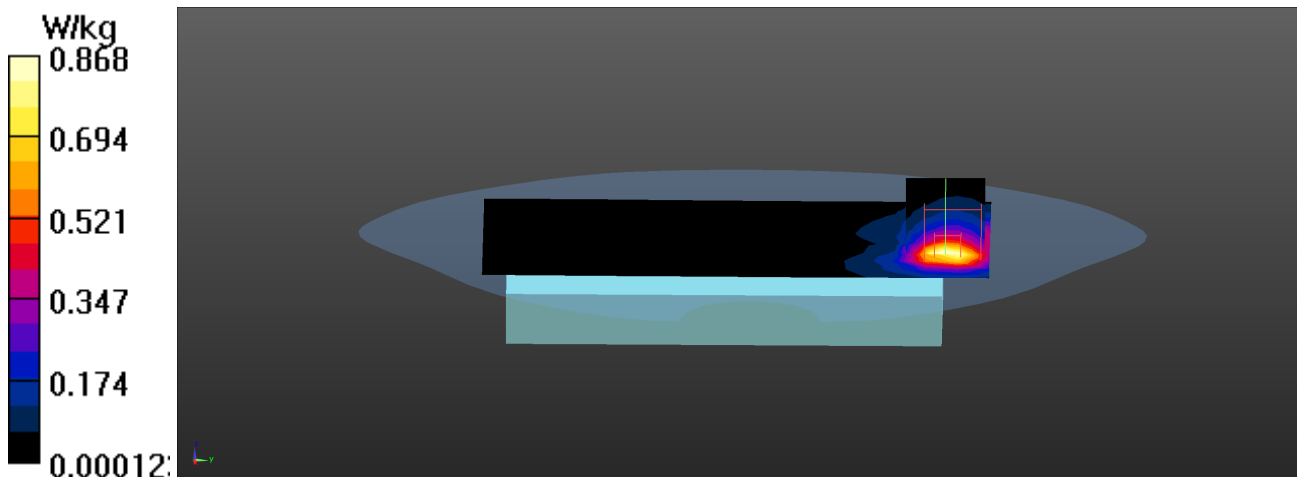

Test Laboratory: DEKRA

Date: 2022/12/17

24_LTE_Band7_QPSK_20M_20850_1RB-50_Bottom_10mm

DUT: Mobile Computer; Type: RS36

Communication System: UID 0, LTE Band7; Frequency: 2510 MHz;

Communication System PAR: 0 dB

Medium parameters used: $f = 2510$ MHz; $\sigma = 1.91$ S/m; $\epsilon_r = 38.97$; $\rho = 1000$ kg/m³

Phantom section: Flat Section

Ambient Temperature (°C) : 22.8, Liquid Temperature (°C) : 21.7

Measurement Standard: DASYS (IEEE/IEC/ANSI C63.19-2011)

DASY5 Configuration:

- Probe: EX3DV4 - SN3979; ConvF(7.38, 7.38, 7.38); Calibrated: 2022/11/23;
- Sensor-Surface: 1.4mm (Mechanical Surface Detection)
- Electronics: DAE4 Sn1425; Calibrated: 2022/11/23
- Phantom: SAM with right table; Type: SAM;
- Measurement SW: DASYS2, Version 52.10 (0); SEMCAD X Version 14.6.10 (7417)

Configuration/Flat/Area Scan (7x10x1): Measurement grid: dx=12mm, dy=12mm

Maximum value of SAR (measured) = 1.13 W/kg

Configuration/Flat/Zoom Scan (7x7x7)/Cube 0: Measurement grid: dx=5mm, dy=5mm, dz=5mm

Reference Value = 27.19 V/m; Power Drift = 0.04 dB

Peak SAR (extrapolated) = 1.71 W/kg

SAR(1 g) = 0.900 W/kg; SAR(10 g) = 0.463 W/kg

Maximum value of SAR (measured) = 1.40 W/kg

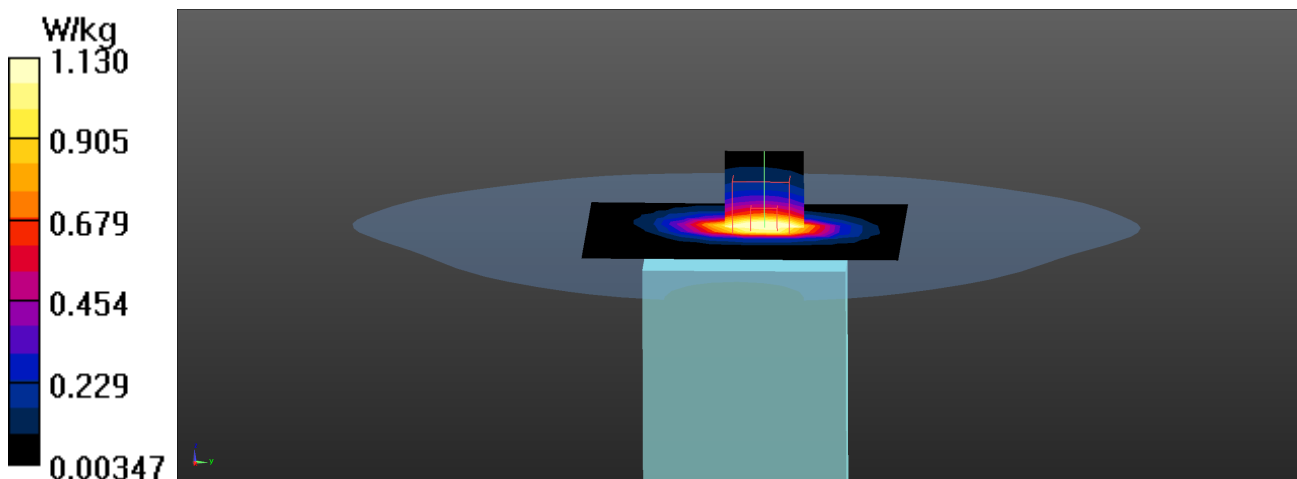

LTE Band 7 QPSK 20M EUT 1RB-50_Bottom_10mm_Body, Z-Axis plot

Channel: 20850

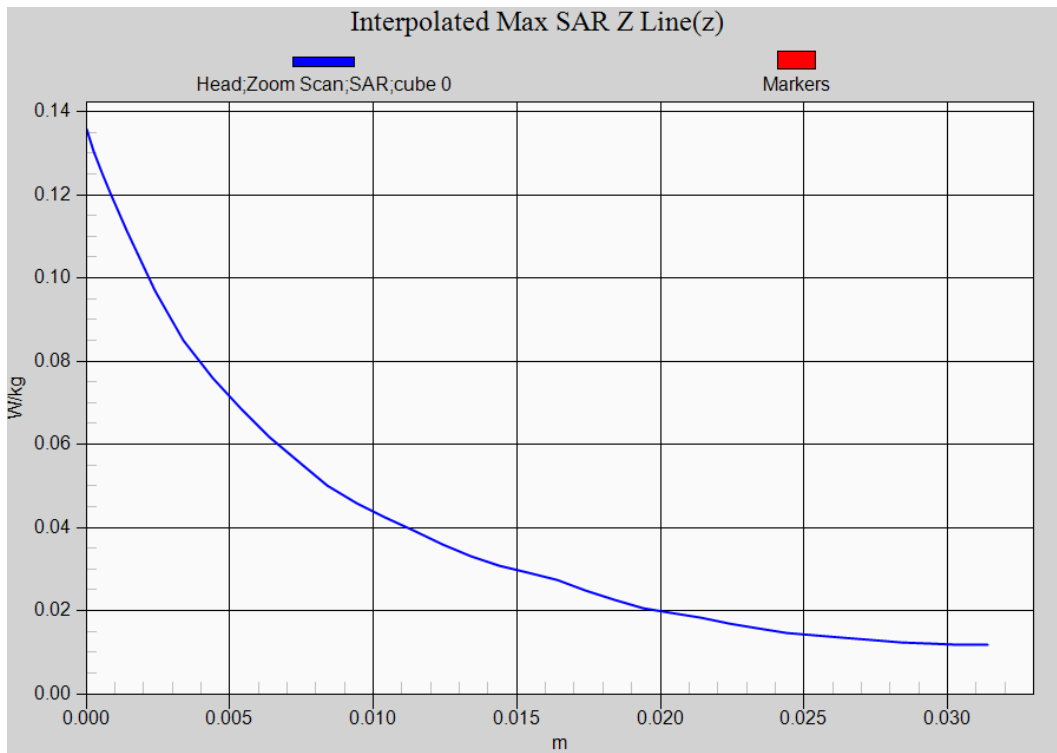

Test Laboratory: DEKRA

Date: 2022/12/18

25_LTE_Band12_QPSK_10M_23130_1RB-25_Left-Check**DUT: Mobile Computer; Type: RS36**

Communication System: UID 0, LTE Band12; Frequency: 711 MHz;

Communication System PAR: 0 dB

Medium parameters used: $f = 711$ MHz; $\sigma = 0.88$ S/m; $\epsilon_r = 42.24$; $\rho = 1000$ kg/m³

Phantom section: Left Section

Ambient Temperature (°C) : 23.2, Liquid Temperature (°C) : 22.1

Measurement Standard: DASYS5 (IEEE/IEC/ANSI C63.19-2011)

DASY5 Configuration:

- Probe: EX3DV4 - SN3979; ConvF(10.47, 10.47, 10.47); Calibrated: 2022/11/23;
- Sensor-Surface: 1.4mm (Mechanical Surface Detection)
- Electronics: DAE4 Sn1425; Calibrated: 2022/11/23
- Phantom: SAM with right table; Type: SAM;
- Measurement SW: DASYS52, Version 52.10 (0); SEMCAD X Version 14.6.10 (7417)

Configuration/Head/Area Scan (8x14x1): Measurement grid: dx=15mm, dy=15mm

Maximum value of SAR (measured) = 0.452 W/kg

Configuration/Head/Zoom Scan (5x5x7)/Cube 0: Measurement grid: dx=8mm, dy=8mm, dz=5mm

Reference Value = 6.141 V/m; Power Drift = 0.04 dB

Peak SAR (extrapolated) = 0.480 W/kg

SAR(1 g) = 0.359 W/kg; SAR(10 g) = 0.271 W/kg

Maximum value of SAR (measured) = 0.433 W/kg

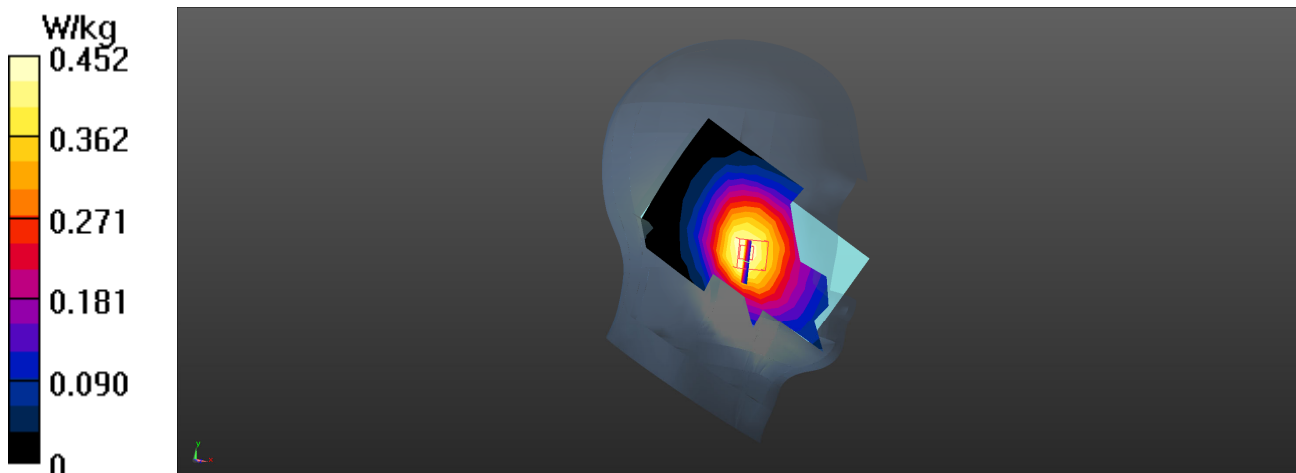

LTE Band 12 QPSK 10M EUT 1RB-25_Left-Check_0mm_Head, Z-Axis plot

Channel: 23130

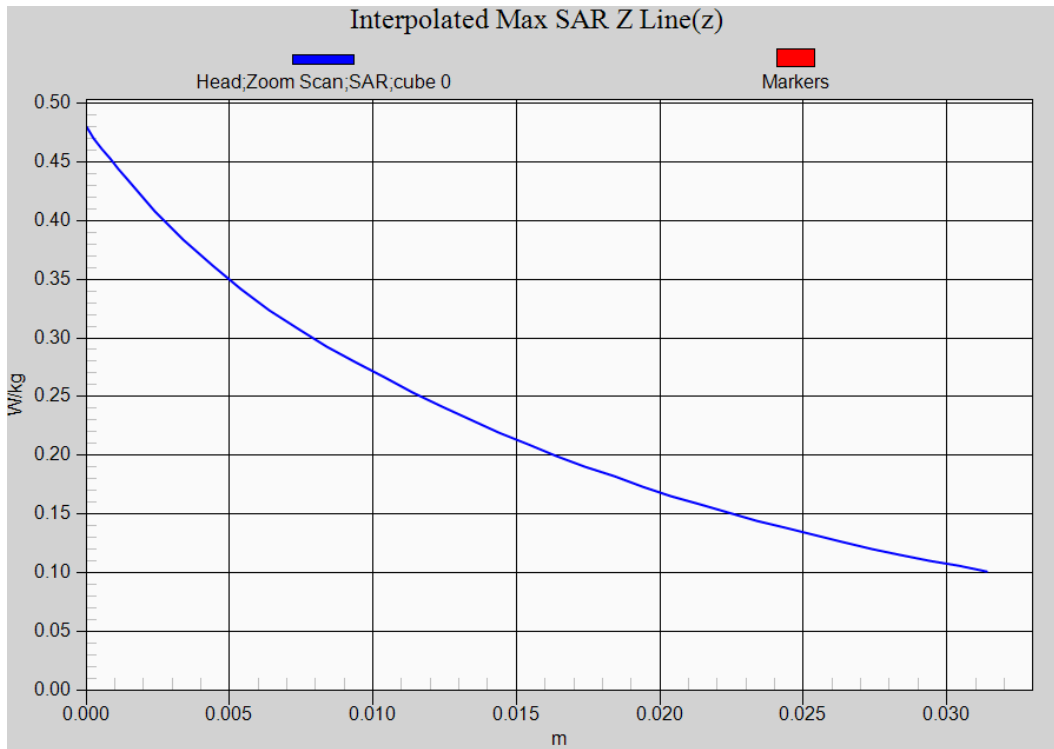

Test Laboratory: DEKRA

Date: 2022/12/18

26_LTE_Band12_QPSK_10M_23130_1RB-25_Front_10mm**DUT: Mobile Computer; Type: RS36**

Communication System: UID 0, LTE Band12; Frequency: 711 MHz;

Communication System PAR: 0 dB

Medium parameters used: $f = 711 \text{ MHz}$; $\sigma = 0.88 \text{ S/m}$; $\epsilon_r = 42.24$; $\rho = 1000 \text{ kg/m}^3$

Phantom section: Flat Section

Ambient Temperature ($^{\circ}\text{C}$) : 23.2, Liquid Temperature ($^{\circ}\text{C}$) : 22.1

Measurement Standard: DASYS5 (IEEE/IEC/ANSI C63.19-2011)

DASY5 Configuration:

- Probe: EX3DV4 - SN3979; ConvF(10.47, 10.47, 10.47); Calibrated: 2022/11/23;
- Sensor-Surface: 1.4mm (Mechanical Surface Detection)
- Electronics: DAE4 Sn1425; Calibrated: 2022/11/23
- Phantom: SAM with right table; Type: SAM;
- Measurement SW: DASYS52, Version 52.10 (0); SEMCAD X Version 14.6.10 (7417)

Configuration/Flat/Area Scan (8x14x1): Measurement grid: $dx=15\text{mm}$, $dy=15\text{mm}$

Maximum value of SAR (measured) = 0.414 W/kg

Configuration/Flat/Zoom Scan (5x5x7)/Cube 0: Measurement grid: $dx=8\text{mm}$, $dy=8\text{mm}$, $dz=5\text{mm}$

Reference Value = 22.88 V/m; Power Drift = -0.07 dB

Peak SAR (extrapolated) = 0.450 W/kg

SAR(1 g) = 0.349 W/kg; SAR(10 g) = 0.268 W/kg

Maximum value of SAR (measured) = 0.416 W/kg

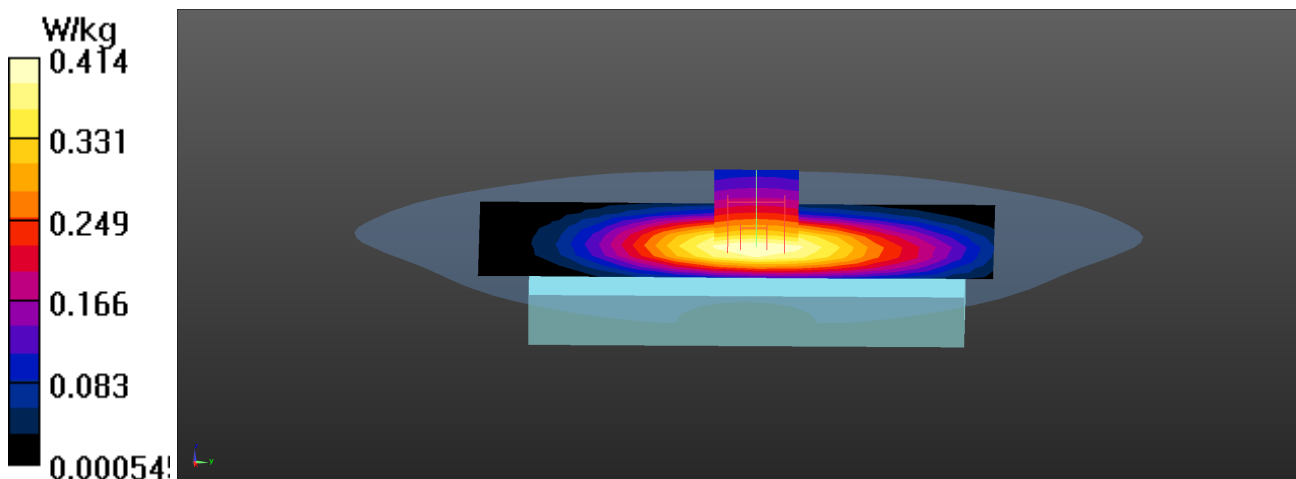

LTE Band 12 QPSK 10M EUT 1RB-25_ Front_10mm _Body, Z-Axis plot

Channel: 23130

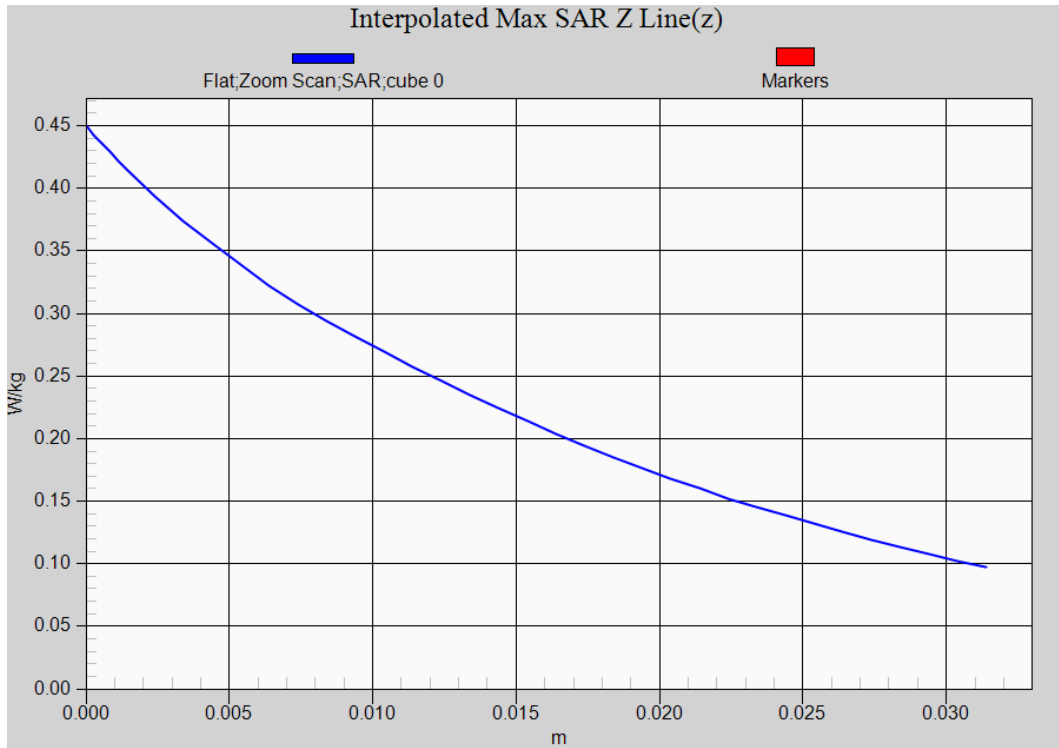

Test Laboratory: DEKRA

Date: 2022/12/18

27_LTE_Band13_QPSK_10M_23230_1RB-25_Left-Check**DUT: Mobile Computer; Type: RS36**

Communication System: UID 0, LTE Band13; Frequency: 782 MHz;

Communication System PAR: 0 dB

Medium parameters used: $f = 782$ MHz; $\sigma = 0.89$ S/m; $\epsilon_r = 41.32$; $\rho = 1000$ kg/m³

Phantom section: Left Section

Ambient Temperature (°C) : 23.2, Liquid Temperature (°C) : 22.1

Measurement Standard: DASYS5 (IEEE/IEC/ANSI C63.19-2011)

DASY5 Configuration:

- Probe: EX3DV4 - SN3979; ConvF(10.47, 10.47, 10.47); Calibrated: 2022/11/23;
- Sensor-Surface: 1.4mm (Mechanical Surface Detection)
- Electronics: DAE4 Sn1425; Calibrated: 2022/11/23
- Phantom: SAM with right table; Type: SAM;
- Measurement SW: DASYS52, Version 52.10 (0); SEMCAD X Version 14.6.10 (7417)

Configuration/Head/Area Scan (8x14x1): Measurement grid: dx=15mm, dy=15mm

Maximum value of SAR (measured) = 0.410 W/kg

Configuration/Head/Zoom Scan (5x5x7)/Cube 0: Measurement grid: dx=8mm, dy=8mm, dz=5mm

Reference Value = 5.680 V/m; Power Drift = 0.01 dB

Peak SAR (extrapolated) = 0.448 W/kg

SAR(1 g) = 0.336 W/kg; SAR(10 g) = 0.243 W/kg

Maximum value of SAR (measured) = 0.407 W/kg

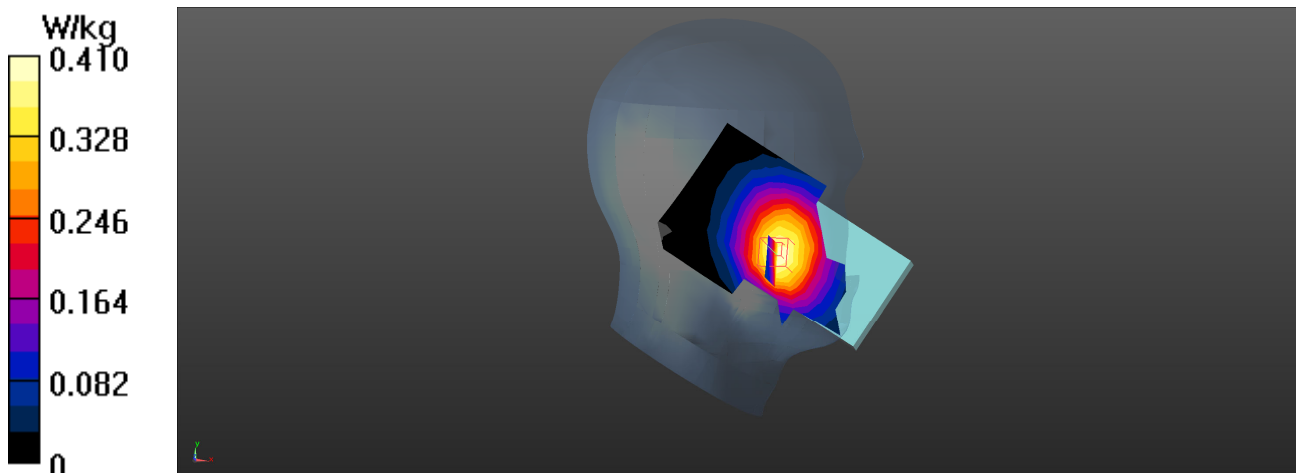

LTE Band 13 QPSK 10M EUT 1RB-25_Left-Check_0mm_Head, Z-Axis plot

Channel: 23230

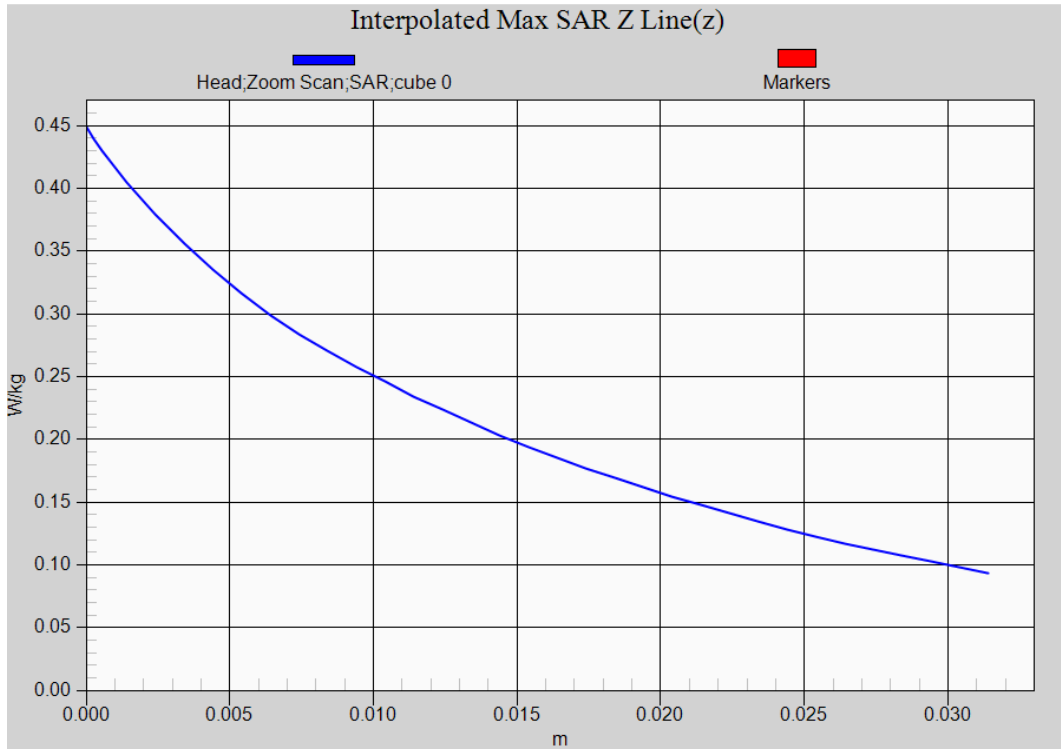

Test Laboratory: DEKRA

Date: 2022/12/18

28_LTE_Band13_QPSK_10M_23230_1RB-25_Front_10mm**DUT: Mobile Computer; Type: RS36**

Communication System: UID 0, LTE Band13; Frequency: 782 MHz;

Communication System PAR: 0 dB

Medium parameters used: $f = 782$ MHz; $\sigma = 0.89$ S/m; $\epsilon_r = 41.32$; $\rho = 1000$ kg/m³

Phantom section: Flat Section

Ambient Temperature (°C) : 23.2, Liquid Temperature (°C) : 22.1

Measurement Standard: DASYS5 (IEEE/IEC/ANSI C63.19-2011)

DASY5 Configuration:

- Probe: EX3DV4 - SN3979; ConvF(10.47, 10.47, 10.47); Calibrated: 2022/11/23;
- Sensor-Surface: 1.4mm (Mechanical Surface Detection)
- Electronics: DAE4 Sn1425; Calibrated: 2022/11/23
- Phantom: SAM with right table; Type: SAM;
- Measurement SW: DASYS52, Version 52.10 (0); SEMCAD X Version 14.6.10 (7417)

Configuration/Flat/Area Scan (8x14x1): Measurement grid: dx=15mm, dy=15mm

Maximum value of SAR (measured) = 0.367 W/kg

Configuration/Flat/Zoom Scan (5x5x7)/Cube 0: Measurement grid: dx=8mm, dy=8mm, dz=5mm

Reference Value = 21.44 V/m; Power Drift = 0.12 dB

Peak SAR (extrapolated) = 0.424 W/kg

SAR(1 g) = 0.331 W/kg; SAR(10 g) = 0.250 W/kg

Maximum value of SAR (measured) = 0.394 W/kg

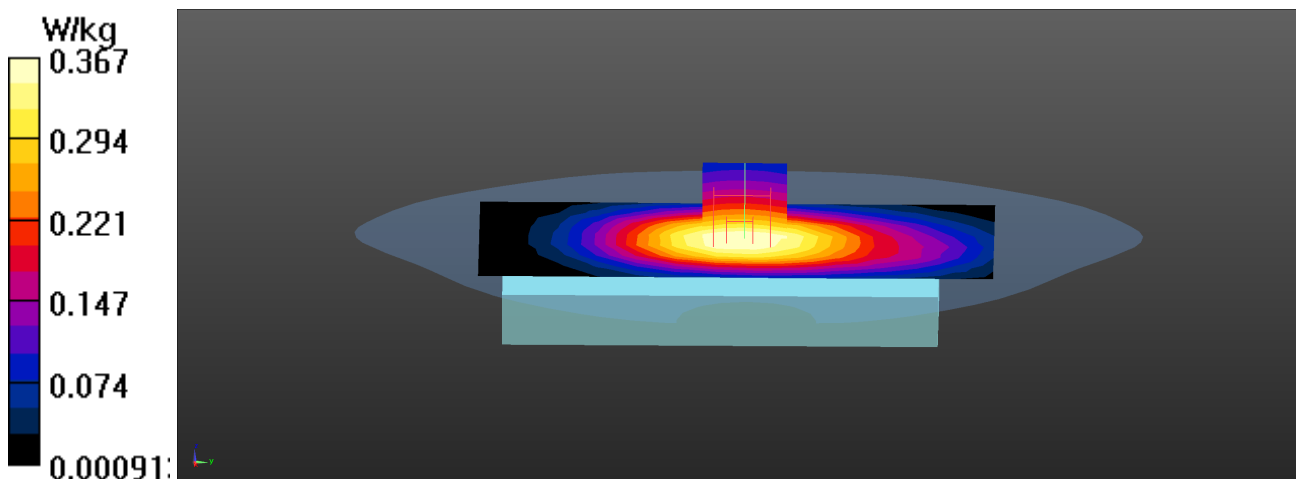

LTE Band 13 QPSK 10M EUT 1RB-25_Front_10mm_Body, Z-Axis plot

Channel: 23230

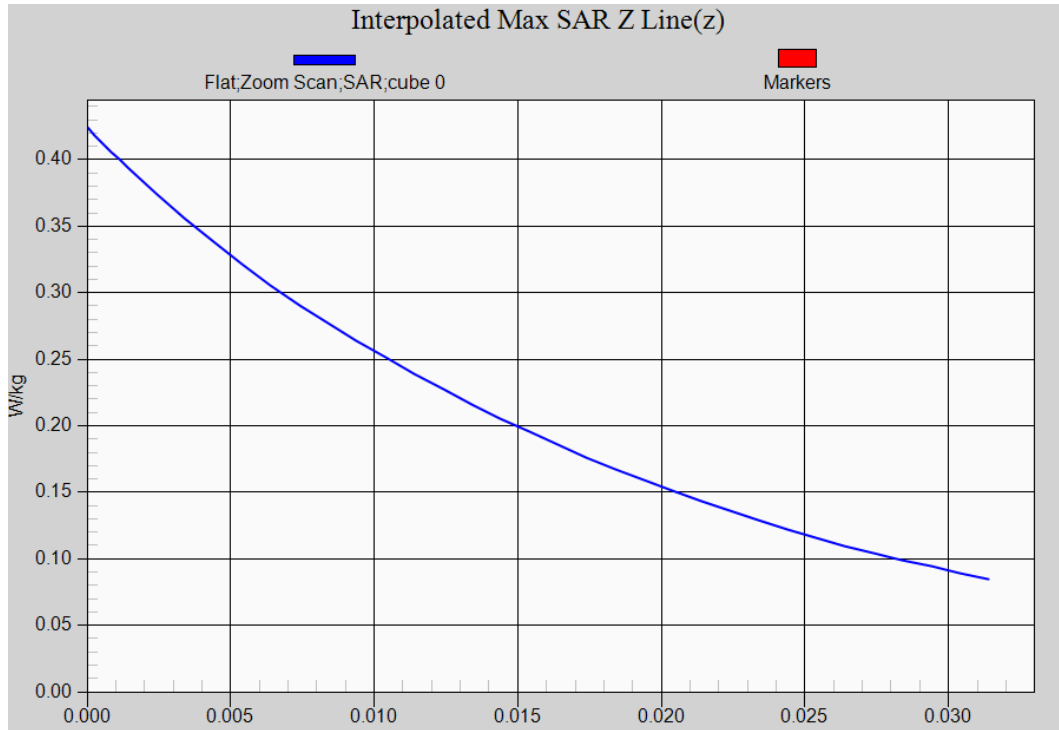

Test Laboratory: DEKRA

Date: 2022/12/17

29_LTE_Band25_QPSK_20M_26590_1RB-50_Left-Check**DUT: Mobile Computer; Type: RS36**

Communication System: UID 0, LTE Band25; Frequency: 1905 MHz;

Communication System PAR: 0 dB

Medium parameters used: $f = 1905$ MHz; $\sigma = 1.38$ S/m; $\epsilon_r = 39.54$; $\rho = 1000$ kg/m³

Phantom section: Left Section

Ambient Temperature (°C) : 22.8, Liquid Temperature (°C) : 21.7

Measurement Standard: DASYS (IEEE/IEC/ANSI C63.19-2011)

DASY5 Configuration:

- Probe: EX3DV4 - SN3979; ConvF(8.12, 8.12, 8.12); Calibrated: 2022/11/23;
- Sensor-Surface: 1.4mm (Mechanical Surface Detection)
- Electronics: DAE4 Sn1425; Calibrated: 2022/11/23
- Phantom: SAM with right table; Type: SAM;
- Measurement SW: DASYS2, Version 52.10 (0); SEMCAD X Version 14.6.10 (7417)

Configuration/Head/Area Scan (8x14x1): Measurement grid: dx=15mm, dy=15mm

Maximum value of SAR (measured) = 0.697 W/kg

Configuration/Head/Zoom Scan (5x5x7)/Cube 0: Measurement grid: dx=8mm, dy=8mm, dz=5mm

Reference Value = 6.121 V/m; Power Drift = 0.04 dB

Peak SAR (extrapolated) = 0.818 W/kg

SAR(1 g) = 0.522 W/kg; SAR(10 g) = 0.324 W/kg

Maximum value of SAR (measured) = 0.711 W/kg

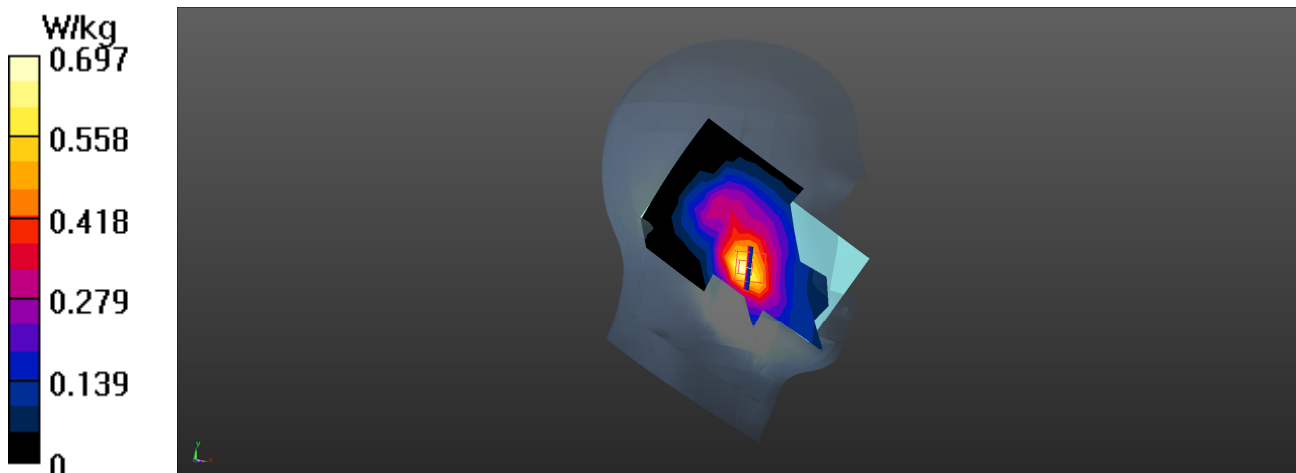

LTE Band 25 QPSK 20M EUT 1RB-50_Left-Check_0mm_Head, Z-Axis plot

Channel: 26590

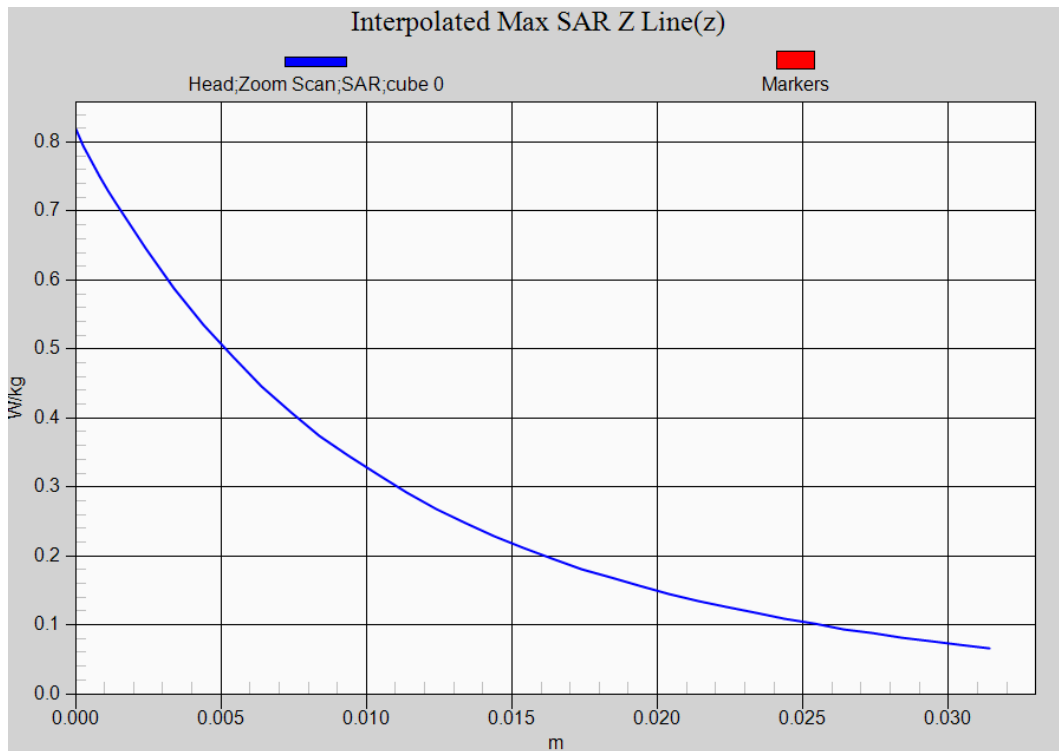

Test Laboratory: DEKRA

Date: 2022/12/17

30_LTE_Band25_QPSK_20M_26365_1RB-50_Back_10mm**DUT: Mobile Computer; Type: RS36**

Communication System: UID 0, LTE Band25; Frequency: 1882.5 MHz;

Communication System PAR: 0 dB

Medium parameters used: $f = 1882.5$ MHz; $\sigma = 1.37$ S/m; $\epsilon_r = 40.18$; $\rho = 1000$ kg/m³

Phantom section: Flat Section

Ambient Temperature (°C) : 22.8, Liquid Temperature (°C) : 21.7

Measurement Standard: DASYS5 (IEEE/IEC/ANSI C63.19-2011)

DASY5 Configuration:

- Probe: EX3DV4 - SN3979; ConvF(8.12, 8.12, 8.12); Calibrated: 2022/11/23;
- Sensor-Surface: 1.4mm (Mechanical Surface Detection)
- Electronics: DAE4 Sn1425; Calibrated: 2022/11/23
- Phantom: SAM with right table; Type: SAM;
- Measurement SW: DASYS52, Version 52.10 (0); SEMCAD X Version 14.6.10 (7417)

Configuration/Flat/Area Scan (8x15x1): Measurement grid: dx=15mm, dy=15mm

Maximum value of SAR (measured) = 0.881 W/kg

Configuration/Flat/Zoom Scan (5x5x7)/Cube 0: Measurement grid: dx=8mm, dy=8mm, dz=5mm

Reference Value = 26.61 V/m; Power Drift = 0.09 dB

Peak SAR (extrapolated) = 1.13 W/kg

SAR(1 g) = 0.669 W/kg; SAR(10 g) = 0.356 W/kg

Maximum value of SAR (measured) = 0.971 W/kg

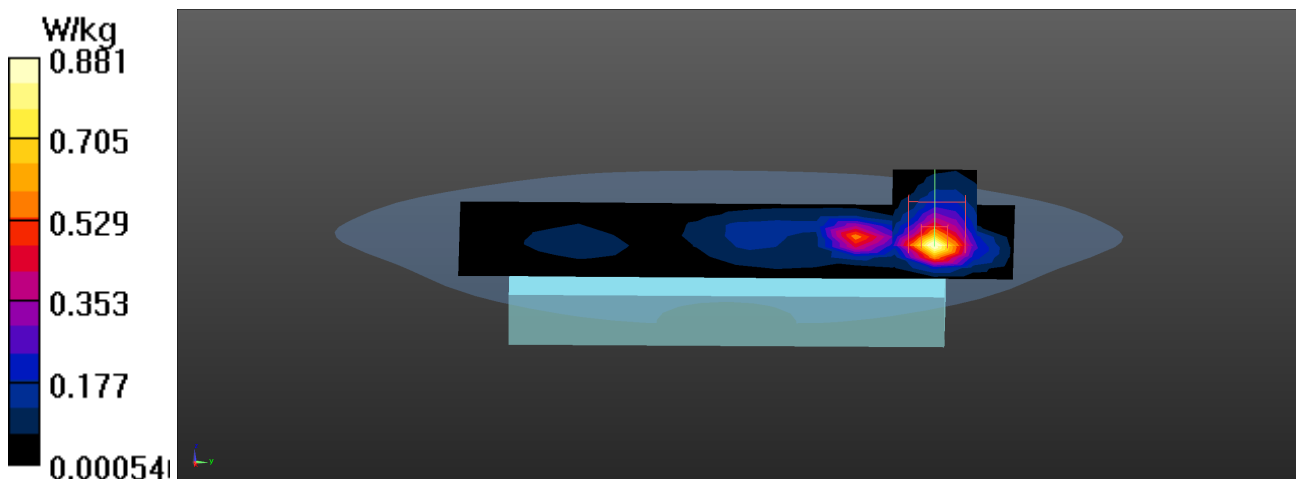

Test Laboratory: DEKRA

Date: 2022/12/17

31_LTE_Band25_QPSK_20M_26590_1RB-50_Bottom_10mm**DUT: Mobile Computer; Type: RS36**

Communication System: UID 0, LTE Band25; Frequency: 1905 MHz;

Communication System PAR: 0 dB

Medium parameters used: $f = 1905$ MHz; $\sigma = 1.38$ S/m; $\epsilon_r = 39.54$; $\rho = 1000$ kg/m³

Phantom section: Flat Section

Ambient Temperature (°C) : 22.8, Liquid Temperature (°C) : 21.7

Measurement Standard: DASYS5 (IEEE/IEC/ANSI C63.19-2011)

DASY5 Configuration:

- Probe: EX3DV4 - SN3979; ConvF(8.12, 8.12, 8.12); Calibrated: 2022/11/23;
- Sensor-Surface: 1.4mm (Mechanical Surface Detection)
- Electronics: DAE4 Sn1425; Calibrated: 2022/11/23
- Phantom: SAM with right table; Type: SAM;
- Measurement SW: DASYS52, Version 52.10 (0); SEMCAD X Version 14.6.10 (7417)

Configuration/Flat/Area Scan (8x9x1): Measurement grid: dx=15mm, dy=15mm

Maximum value of SAR (measured) = 1.09 W/kg

Configuration/Flat/Zoom Scan (5x5x7)/Cube 0: Measurement grid: dx=8mm, dy=8mm, dz=5mm

Reference Value = 32.08 V/m; Power Drift = 0.03 dB

Peak SAR (extrapolated) = 1.58 W/kg

SAR(1 g) = 0.920 W/kg; SAR(10 g) = 0.512 W/kg

Maximum value of SAR (measured) = 1.35 W/kg

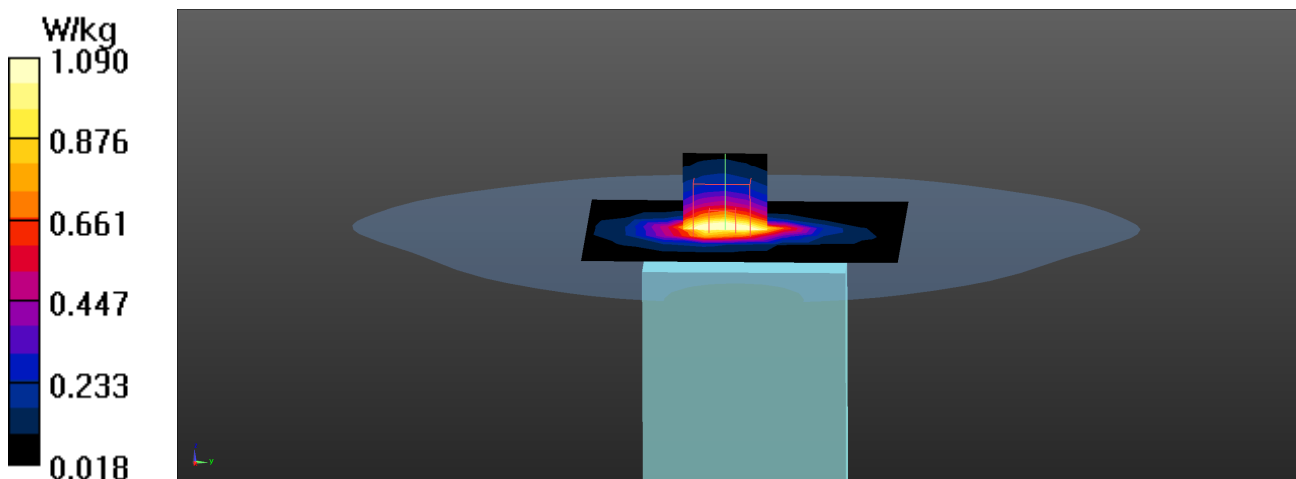

LTE Band 25 QPSK 20M EUT 1RB-50_Bottom_10mm _Body, Z-Axis plot

Channel: 26590

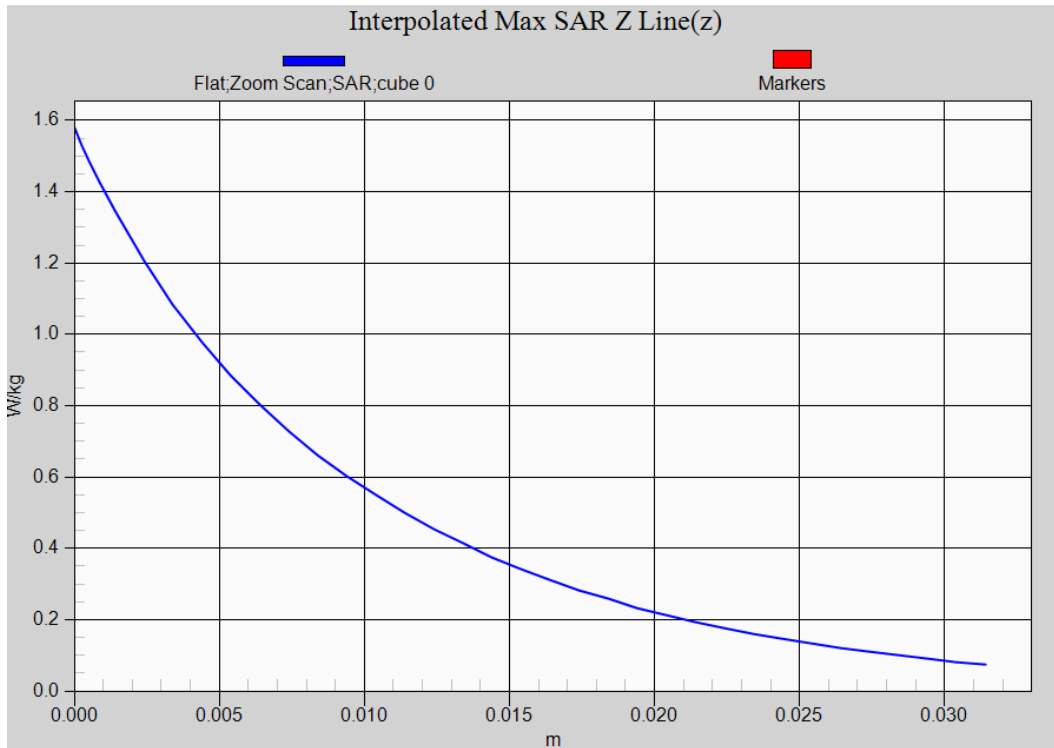

Test Laboratory: DEKRA

Date: 2022/12/18

32_LTE_Band26_QPSK_15M_26915_1RB-36_Left-Check**DUT: Mobile Computer; Type: RS36**

Communication System: UID 0, LTE Band26; Frequency: 836.5 MHz;

Communication System PAR: 0 dB

Medium parameters used: $f = 836.5$ MHz; $\sigma = 0.91$ S/m; $\epsilon_r = 40.62$; $\rho = 1000$ kg/m³

Phantom section: Left Section

Ambient Temperature (°C) : 23.2, Liquid Temperature (°C) : 22.1

Measurement Standard: DASYS5 (IEEE/IEC/ANSI C63.19-2011)

DASY5 Configuration:

- Probe: EX3DV4 - SN3979; ConvF(10.05, 10.05, 10.05); Calibrated: 2022/11/23;
- Sensor-Surface: 1.4mm (Mechanical Surface Detection)
- Electronics: DAE4 Sn1425; Calibrated: 2022/11/23
- Phantom: SAM with right table; Type: SAM;
- Measurement SW: DASYS52, Version 52.10 (0); SEMCAD X Version 14.6.10 (7417)

Configuration/Head/Area Scan (8x14x1): Measurement grid: dx=15mm, dy=15mm

Maximum value of SAR (measured) = 0.520 W/kg

Configuration/Head/Zoom Scan (5x5x7)/Cube 0: Measurement grid: dx=8mm, dy=8mm, dz=5mm

Reference Value = 7.124 V/m; Power Drift = 0.01 dB

Peak SAR (extrapolated) = 0.546 W/kg

SAR(1 g) = 0.411 W/kg; SAR(10 g) = 0.309 W/kg

Maximum value of SAR (measured) = 0.499 W/kg

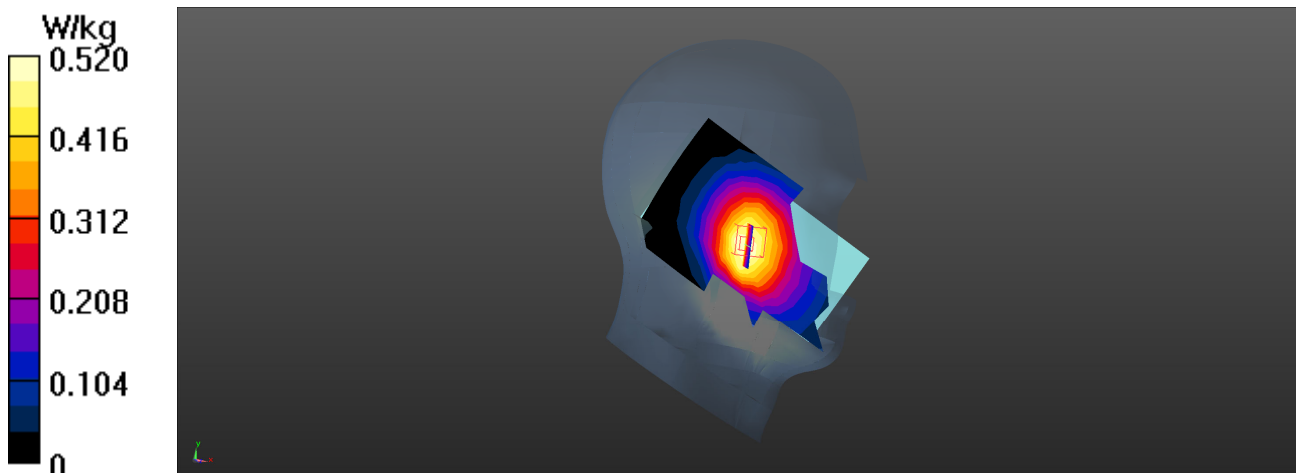

LTE Band 26 QPSK 15M EUT 1RB-36_Left-Check_0mm_Head, Z-Axis plot

Channel: 26915

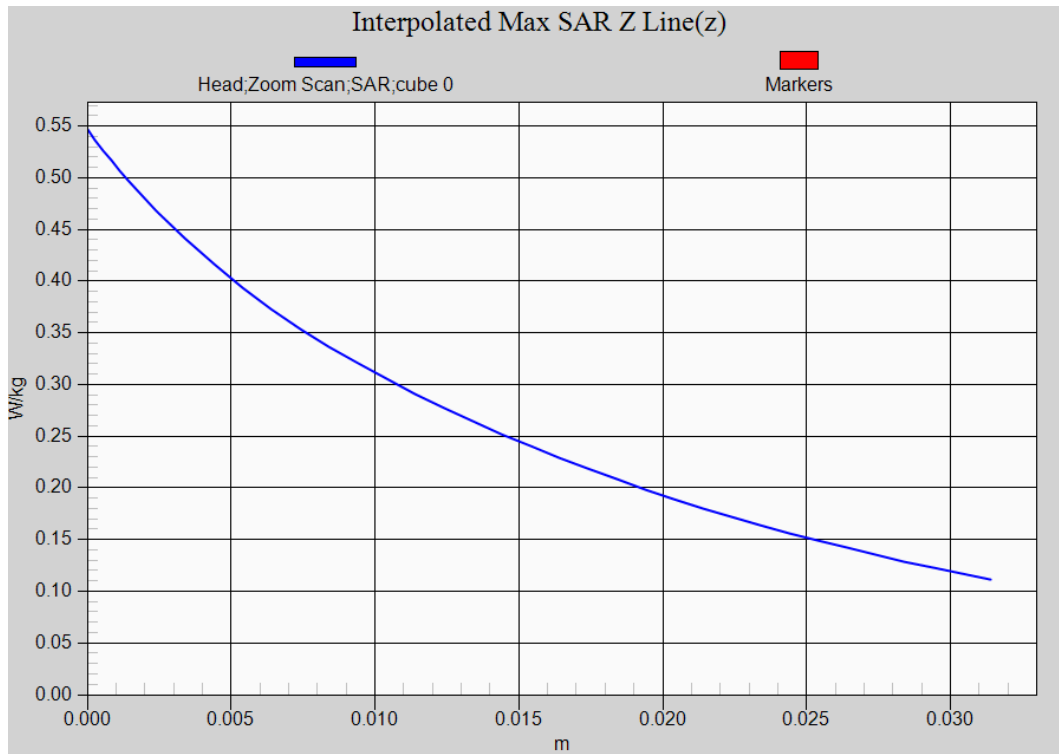

Test Laboratory: DEKRA

Date: 2022/12/18

33_LTE_Band26_QPSK_15M_26915_1RB-36_Front_10mm**DUT: Mobile Computer; Type: RS36**

Communication System: UID 0, LTE Band26; Frequency: 836.5 MHz;

Communication System PAR: 0 dB

Medium parameters used: $f = 836.5$ MHz; $\sigma = 0.91$ S/m; $\epsilon_r = 40.62$; $\rho = 1000$ kg/m³

Phantom section: Flat Section

Ambient Temperature (°C) : 23.2, Liquid Temperature (°C) : 22.1

Measurement Standard: DASYS (IEEE/IEC/ANSI C63.19-2011)

DASY5 Configuration:

- Probe: EX3DV4 - SN3979; ConvF(10.05, 10.05, 10.05); Calibrated: 2022/11/23;
- Sensor-Surface: 1.4mm (Mechanical Surface Detection)
- Electronics: DAE4 Sn1425; Calibrated: 2022/11/23
- Phantom: SAM with right table; Type: SAM;
- Measurement SW: DASYS2, Version 52.10 (0); SEMCAD X Version 14.6.10 (7417)

Configuration/Head/Area Scan (8x14x1): Measurement grid: dx=15mm, dy=15mm

Maximum value of SAR (measured) = 0.420 W/kg

Configuration/Head/Zoom Scan (5x5x7)/Cube 0: Measurement grid: dx=8mm, dy=8mm, dz=5mm

Reference Value = 21.93 V/m; Power Drift = -0.02 dB

Peak SAR (extrapolated) = 0.464 W/kg

SAR(1 g) = 0.355 W/kg; SAR(10 g) = 0.270 W/kg

Maximum value of SAR (measured) = 0.427 W/kg

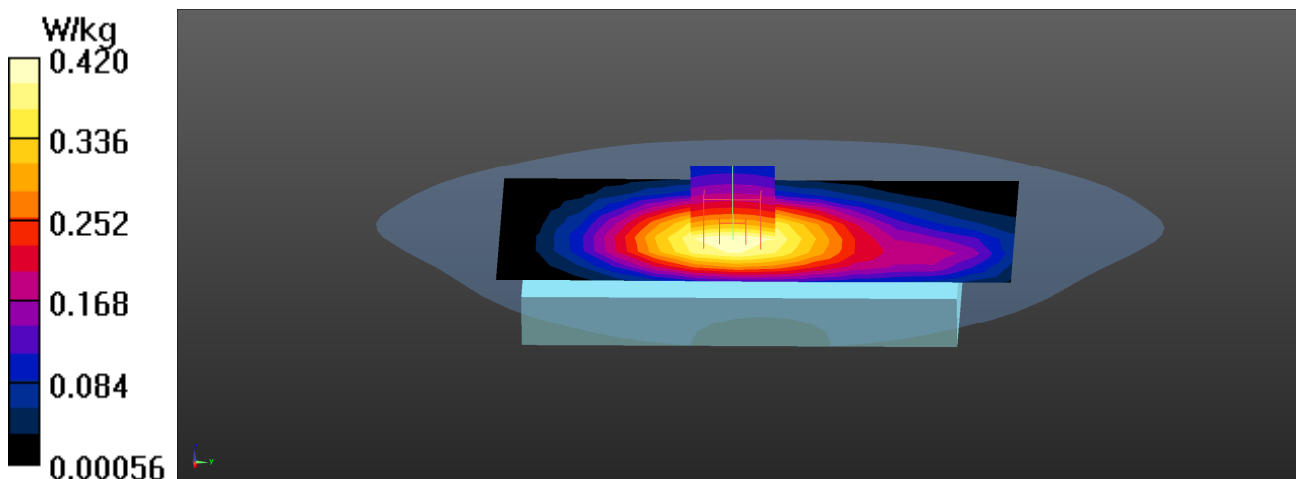

LTE Band 26 QPSK 15M EUT 1RB-36_Front_10mm_Body, Z-Axis plot

Channel: 26915

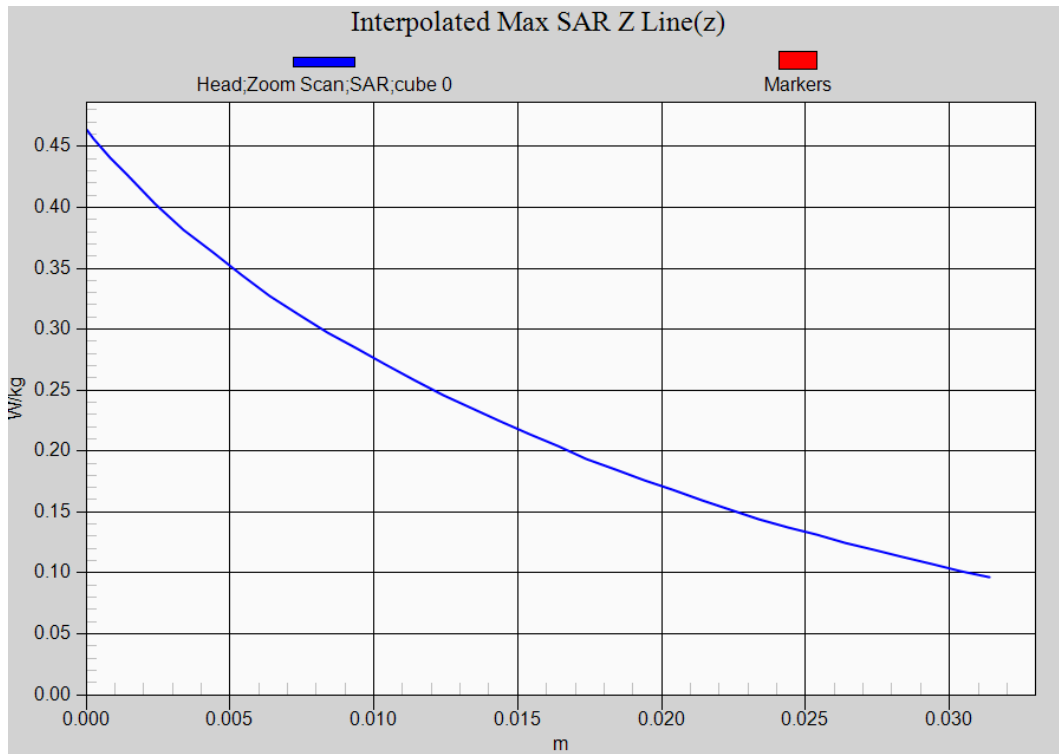

Test Laboratory: DEKRA

Date: 2022/12/17

34_LTE_Band41_QPSK_20M_40620_1RB-50_Left-Check**DUT: Mobile Computer; Type: RS36**

Communication System: UID 0, FCC LTE-TDD Band41; Frequency: 2593 MHz;

Communication System PAR: 2.014 dB

Medium parameters used: $f = 2593$ MHz; $\sigma = 1.95$ S/m; $\epsilon_r = 38.09$; $\rho = 1000$ kg/m³

Phantom section: Left Section

Ambient Temperature (°C) : 22.8, Liquid Temperature (°C) : 21.7

Measurement Standard: DASYS5 (IEEE/IEC/ANSI C63.19-2011)

DASY5 Configuration:

- Probe: EX3DV4 - SN3979; ConvF(7.38, 7.38, 7.38); Calibrated: 2022/11/23;
- Sensor-Surface: 1.4mm (Mechanical Surface Detection)
- Electronics: DAE4 Sn1425; Calibrated: 2022/11/23
- Phantom: SAM with right table; Type: SAM;
- Measurement SW: DASYS52, Version 52.10 (0); SEMCAD X Version 14.6.10 (7417)

Configuration/Head/Area Scan (10x17x1): Measurement grid: dx=12mm, dy=12mm
Maximum value of SAR (measured) = 0.0178 W/kg**Configuration/Head/Zoom Scan (7x7x7)/Cube 0:** Measurement grid: dx=5mm, dy=5mm, dz=5mm

Reference Value = 3.655 V/m; Power Drift = -0.01 dB

Peak SAR (extrapolated) = 0.0320 W/kg

SAR(1 g) = 0.017 W/kg; SAR(10 g) = 0.012 W/kg

Maximum value of SAR (measured) = 0.0272 W/kg

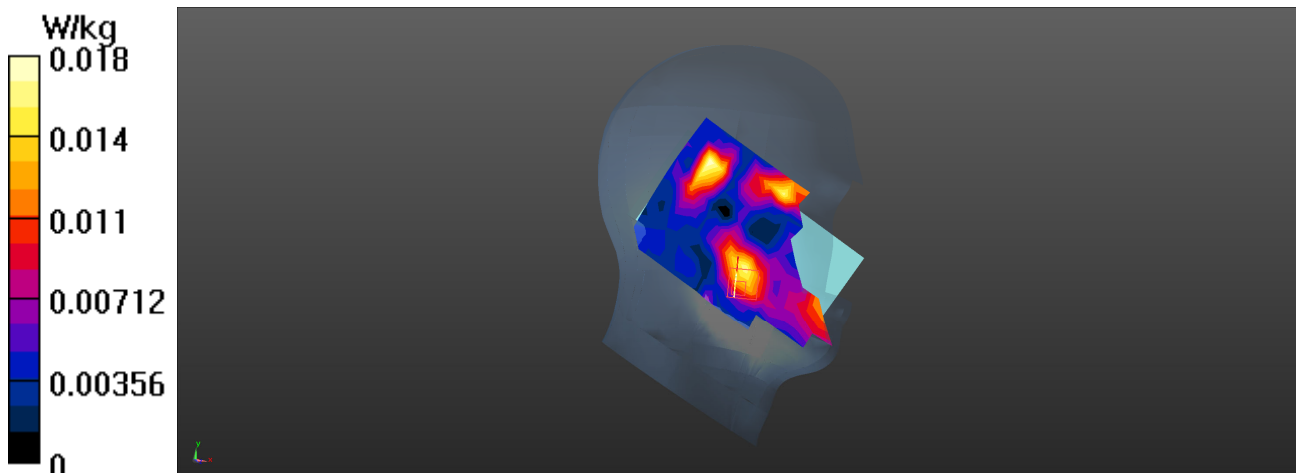

LTE Band 41 QPSK 20M EUT 1RB-50_Left-Check_0mm_Head, Z-Axis plot

Channel: 40620

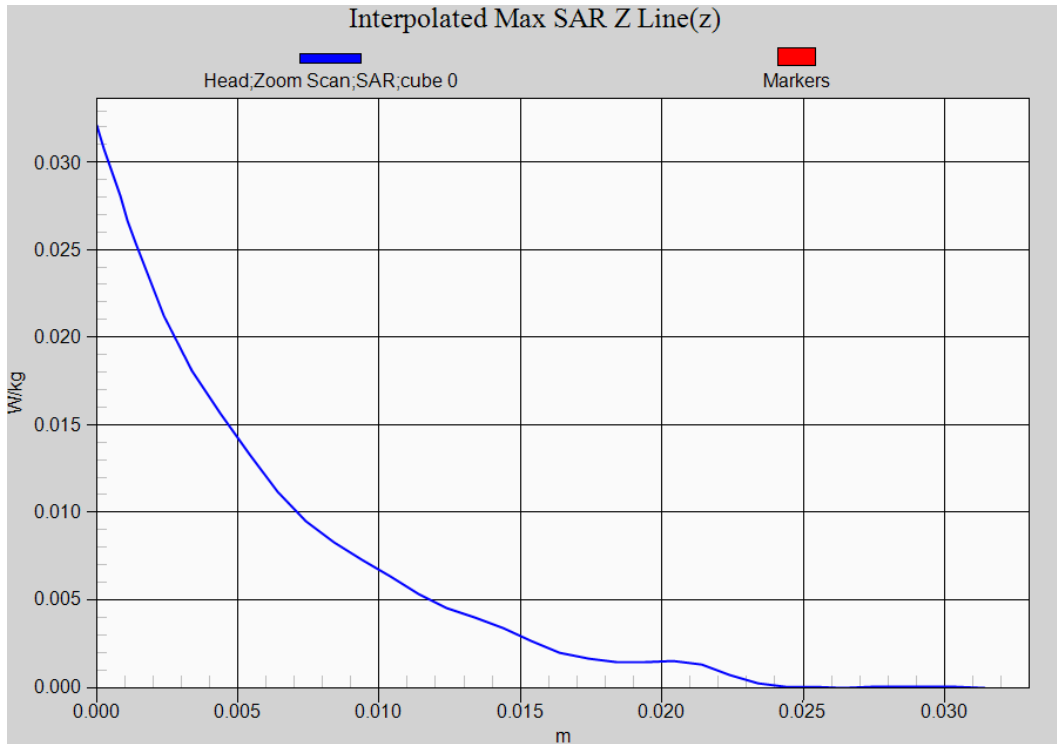

Test Laboratory: DEKRA

Date: 2022/12/17

35_LTE_Band41_QPSK_20M_40240_1RB-50_Back_10mm**DUT: Mobile Computer; Type: RS36**

Communication System: UID 0, FCC LTE-TDD Band41; Frequency: 2555 MHz;

Communication System PAR: 2.014 dB

Medium parameters used: $f = 2555$ MHz; $\sigma = 1.93$ S/m; $\epsilon_r = 38.44$; $\rho = 1000$ kg/m³

Phantom section: Flat Section

Ambient Temperature (°C) : 22.8, Liquid Temperature (°C) : 21.7

Measurement Standard: DASYS5 (IEEE/IEC/ANSI C63.19-2011)

DASY5 Configuration:

- Probe: EX3DV4 - SN3979; ConvF(7.38, 7.38, 7.38); Calibrated: 2022/11/23;
- Sensor-Surface: 1.4mm (Mechanical Surface Detection)
- Electronics: DAE4 Sn1425; Calibrated: 2022/11/23
- Phantom: SAM with right table; Type: SAM;
- Measurement SW: DASYS52, Version 52.10 (0); SEMCAD X Version 14.6.10 (7417)

Configuration/Flat/Area Scan (10x17x1): Measurement grid: dx=12mm, dy=12mm

Maximum value of SAR (measured) = 0.865 W/kg

Configuration/Flat/Zoom Scan (7x7x7)/Cube 0: Measurement grid: dx=5mm, dy=5mm, dz=5mm

Reference Value = 24.73 V/m; Power Drift = -0.04 dB

Peak SAR (extrapolated) = 1.31 W/kg

SAR(1 g) = 0.656 W/kg; SAR(10 g) = 0.321 W/kg

Maximum value of SAR (measured) = 1.06 W/kg

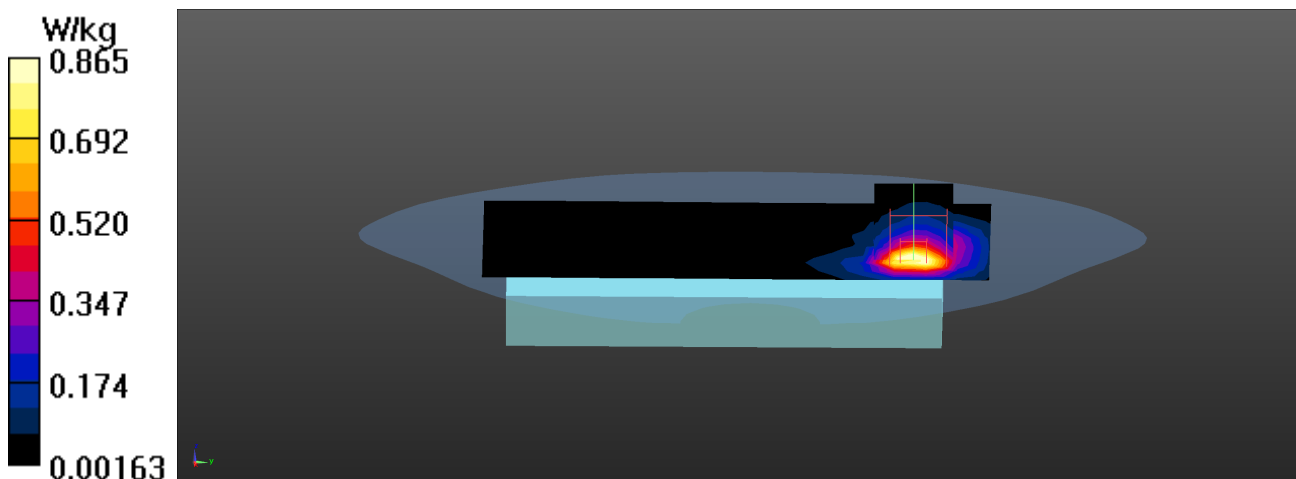

LTE Band 41 QPSK 20M EUT 1RB-50_Back_10mm_Body, Z-Axis plot

Channel: 40620

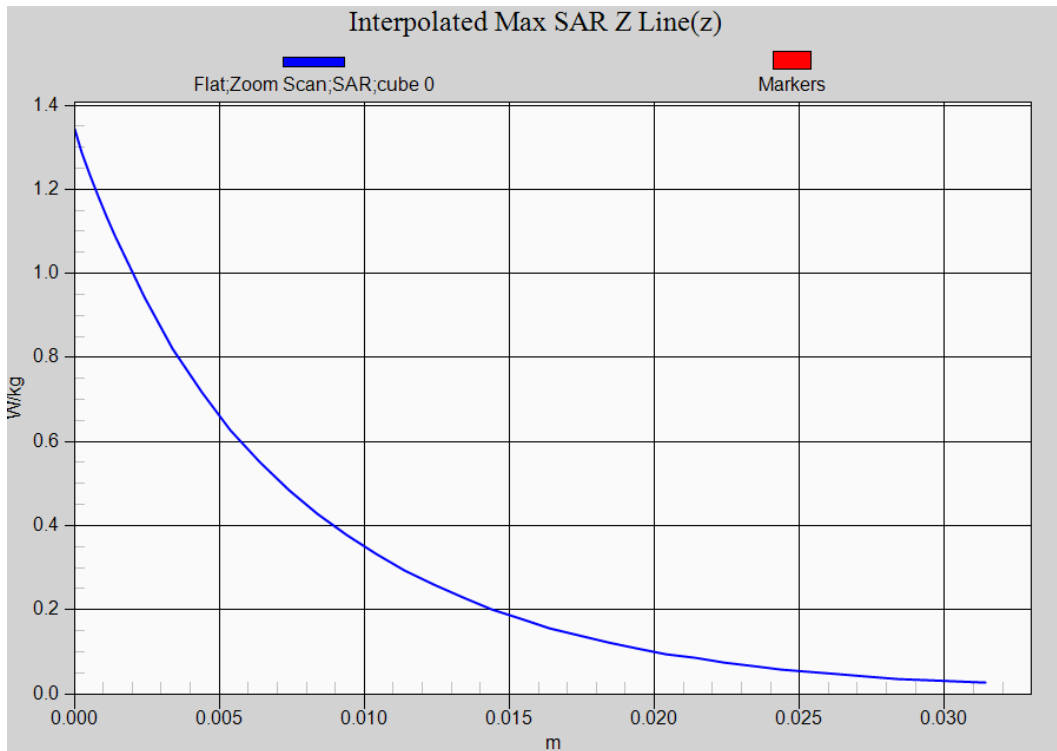

Test Laboratory: DEKRA

Date: 2022/12/27

36_LTE_Band66_QPSK_20M_132572_1RB-50_Left-Cheek**DUT: Mobile Computer; Type: RS36**

Communication System: UID 0, FCC LTE Band66; Frequency: 1770 MHz;

Communication System PAR: 0 dB

Medium parameters used: $f = 1770$ MHz; $\sigma = 1.38$ S/m; $\epsilon_r = 39.41$; $\rho = 1000$ kg/m³

Phantom section: Left Section

Ambient Temperature (°C) : 23.1, Liquid Temperature (°C) : 22.2

Measurement Standard: DASYS5 (IEEE/IEC/ANSI C63.19-2011)

DASY5 Configuration:

- Probe: EX3DV4 - SN3979; ConvF(8.34, 8.34, 8.34); Calibrated: 2022/11/23;
- Sensor-Surface: 1.4mm (Mechanical Surface Detection)
- Electronics: DAE4 Sn1425; Calibrated: 2022/11/23
- Phantom: SAM with right table; Type: SAM;
- Measurement SW: DASYS52, Version 52.10 (0); SEMCAD X Version 14.6.10 (7417)

Configuration/Head/Area Scan (8x14x1): Measurement grid: dx=15mm, dy=15mm

Maximum value of SAR (measured) = 0.219 W/kg

Configuration/Head/Zoom Scan (5x5x7)/Cube 0: Measurement grid: dx=8mm, dy=8mm, dz=5mm

Reference Value = 12.93 V/m; Power Drift = -0.08 dB

Peak SAR (extrapolated) = 0.232 W/kg

SAR(1 g) = 0.144 W/kg; SAR(10 g) = 0.086 W/kg

Maximum value of SAR (measured) = 0.189 W/kg

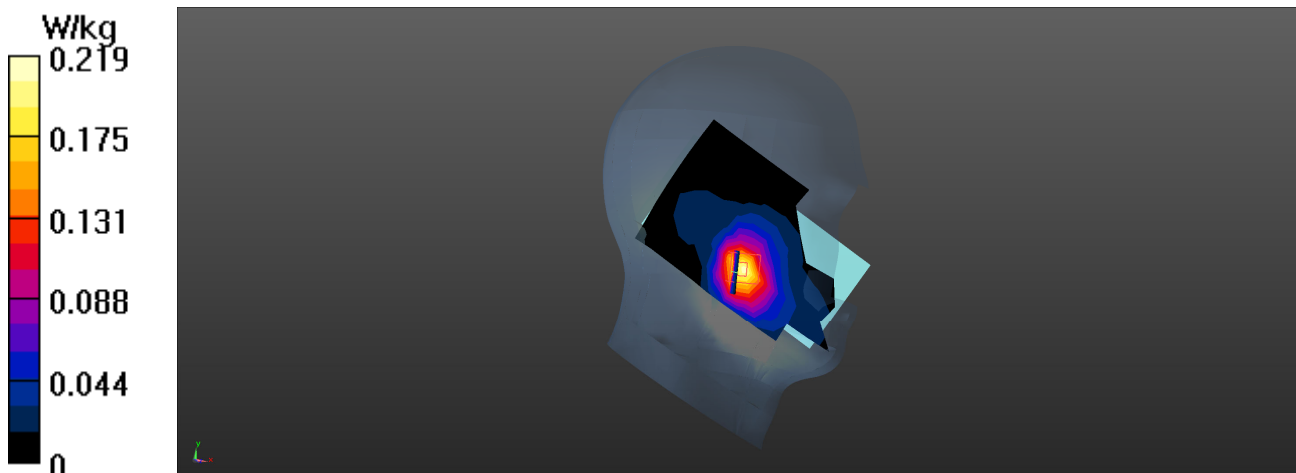

LTE Band 66 QPSK 20M EUT 1RB-50_Left-Cheek_0mm_Head, Z-Axis plot

Channel: 132572

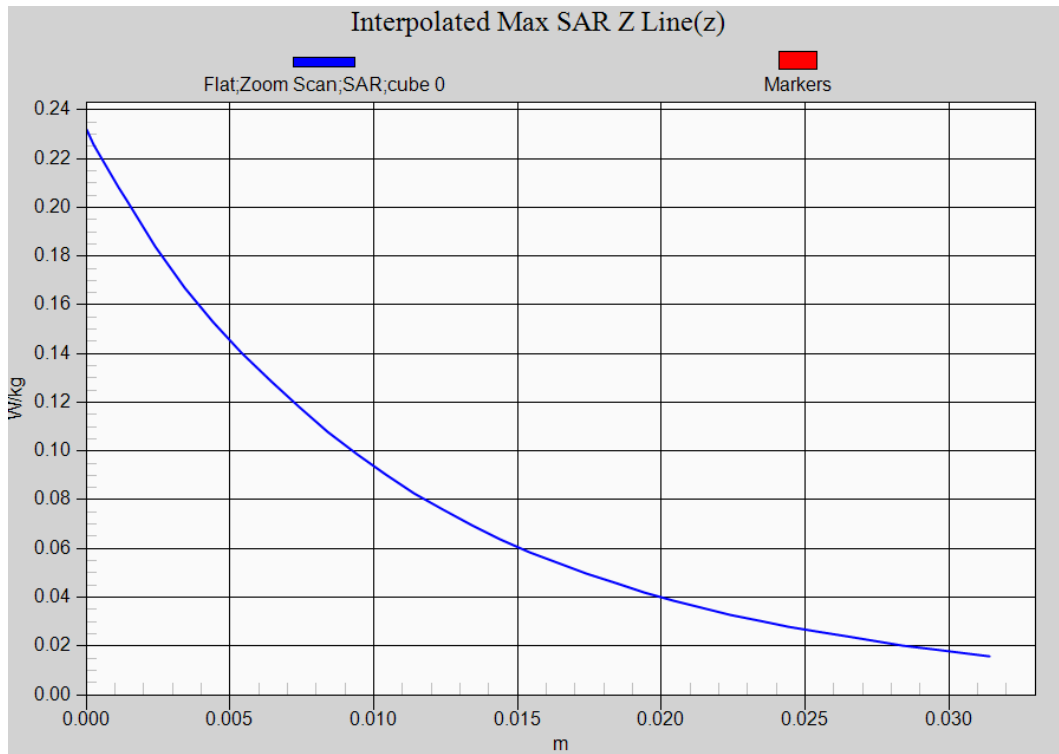

Test Laboratory: DEKRA

Date: 2022/12/27

37_LTE_Band66_QPSK_20M_132322_1RB-50_Back_10mm**DUT: Mobile Computer; Type: RS36**

Communication System: UID 0, FCC LTE Band66; Frequency: 1745 MHz;

Communication System PAR: 0 dB

Medium parameters used: $f = 1745$ MHz; $\sigma = 1.37$ S/m; $\epsilon_r = 39.63$; $\rho = 1000$ kg/m³

Phantom section: Flat Section

Ambient Temperature (°C) : 23.1, Liquid Temperature (°C) : 22.2

Measurement Standard: DASYS5 (IEEE/IEC/ANSI C63.19-2011)

DASY5 Configuration:

- Probe: EX3DV4 - SN3979; ConvF(8.34, 8.34, 8.34); Calibrated: 2022/11/23;
- Sensor-Surface: 1.4mm (Mechanical Surface Detection)
- Electronics: DAE4 Sn1425; Calibrated: 2022/11/23
- Phantom: SAM with right table; Type: SAM;
- Measurement SW: DASYS52, Version 52.10 (0); SEMCAD X Version 14.6.10 (7417)

Configuration/Flat/Area Scan (8x14x1): Measurement grid: dx=15mm, dy=15mm

Maximum value of SAR (measured) = 0.723 W/kg

Configuration/Flat/Zoom Scan (5x5x7)/Cube 0: Measurement grid: dx=8mm, dy=8mm, dz=5mm

Reference Value = 24.56 V/m; Power Drift = -0.07 dB

Peak SAR (extrapolated) = 0.913 W/kg

SAR(1 g) = 0.536 W/kg; SAR(10 g) = 0.310 W/kg

Maximum value of SAR (measured) = 0.775 W/kg

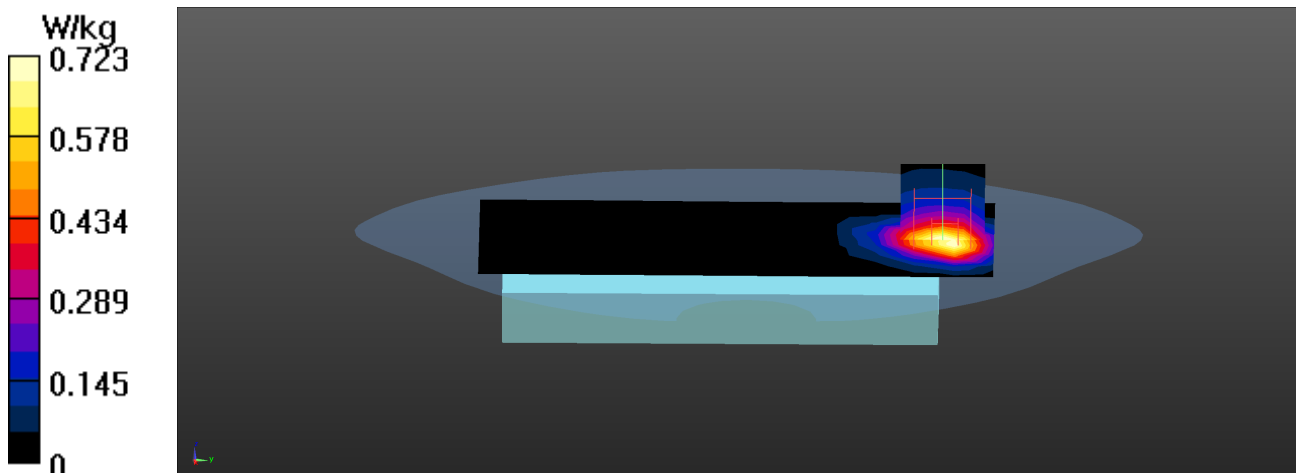

Test Laboratory: DEKRA

Date: 2022/12/27

38_LTE_Band66_QPSK_20M_132072_1RB-50_Bottom_10mm**DUT: Mobile Computer; Type: RS36**

Communication System: UID 0, FCC LTE Band66; Frequency: 1720 MHz;

Communication System PAR: 0 dB

Medium parameters used: $f = 1720$ MHz; $\sigma = 1.37$ S/m; $\epsilon_r = 39.86$; $\rho = 1000$ kg/m³

Phantom section: Flat Section

Ambient Temperature (°C) : 23.1, Liquid Temperature (°C) : 22.2

Measurement Standard: DASYS5 (IEEE/IEC/ANSI C63.19-2011)

DASY5 Configuration:

- Probe: EX3DV4 - SN3979; ConvF(8.34, 8.34, 8.34); Calibrated: 2022/11/23;
- Sensor-Surface: 1.4mm (Mechanical Surface Detection)
- Electronics: DAE4 Sn1425; Calibrated: 2022/11/23
- Phantom: SAM with right table; Type: SAM;
- Measurement SW: DASYS52, Version 52.10 (0); SEMCAD X Version 14.6.10 (7417)

Configuration/Flat/Area Scan (8x9x1): Measurement grid: dx=15mm, dy=15mm

Maximum value of SAR (measured) = 1.06 W/kg

Configuration/Flat/Zoom Scan (5x5x7)/Cube 0: Measurement grid: dx=8mm, dy=8mm, dz=5mm

Reference Value = 27.75 V/m; Power Drift = 0.05 dB

Peak SAR (extrapolated) = 1.25 W/kg

SAR(1 g) = 0.734 W/kg; SAR(10 g) = 0.412 W/kg

Maximum value of SAR (measured) = 1.05 W/kg

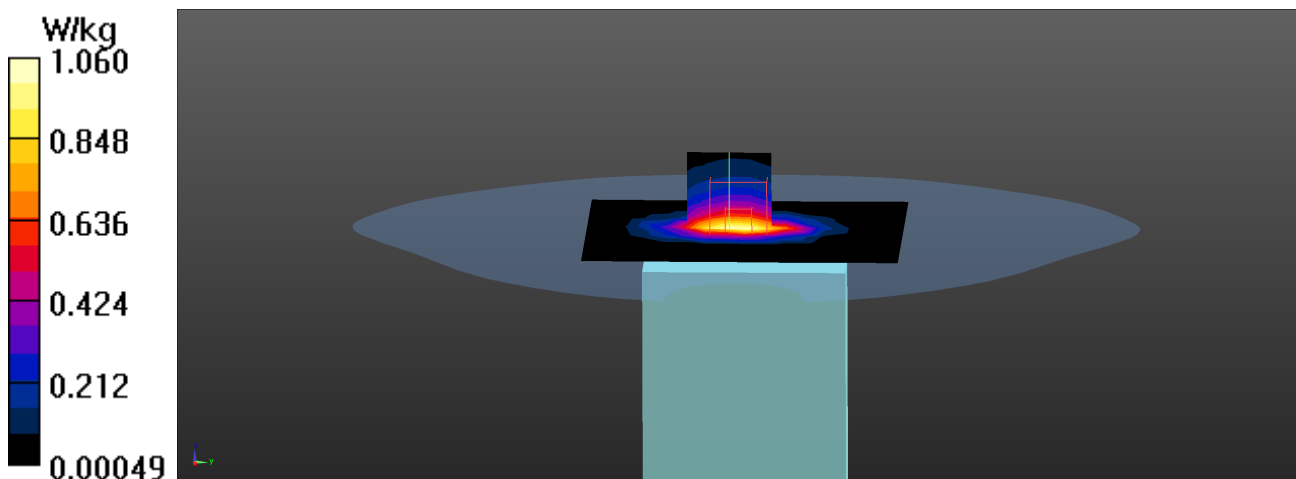

LTE Band 66 QPSK 20M EUT 1RB-50_Bottom_10mm_Body, Z-Axis plot

Channel: 132072

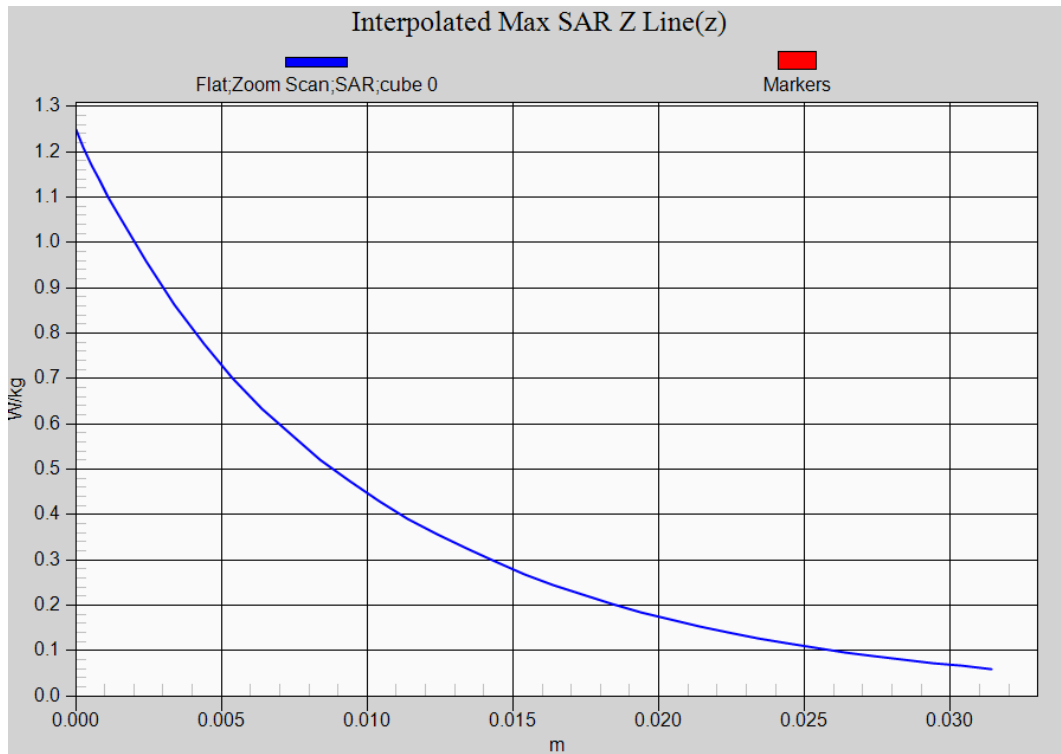

SAR measurement variability

Test Laboratory: DEKRA

Date: 2022/12/12

802.11b_1_Left-Cheek Main-Verify

DUT: Mobile Computer; Type: RS36

Communication System: UID 0, WLAN 2.4G; Frequency: 2412 MHz;

Communication System PAR: 0 dB

Medium parameters used: $f = 2412$ MHz; $\sigma = 1.74$ S/m; $\epsilon_r = 40.13$; $\rho = 1000$ kg/m³

Phantom section: Left Section

Ambient Temperature (°C) : 22.7, Liquid Temperature (°C) : 21.9

Measurement Standard: DASY5 (IEEE/IEC/ANSI C63.19-2011)

DASY5 Configuration:

- Probe: EX3DV4 - SN3979; ConvF(7.58, 7.58, 7.58); Calibrated: 2022/11/23;
- Sensor-Surface: 1.4mm (Mechanical Surface Detection)
- Electronics: DAE4 Sn1425; Calibrated: 2022/11/23
- Phantom: SAM with right table; Type: SAM;
- Measurement SW: DASY52, Version 52.10 (0); SEMCAD X Version 14.6.10 (7417)

Configuration/Head/Area Scan (9x18x1): Measurement grid: dx=12mm, dy=12mm

Maximum value of SAR (measured) = 1.14 W/kg

Configuration/Head/Zoom Scan (7x7x7)/Cube 0: Measurement grid: dx=5mm, dy=5mm, dz=5mm

Reference Value = 26.10 V/m; Power Drift = 0.02 dB

Peak SAR (extrapolated) = 1.52 W/kg

SAR(1 g) = 0.778 W/kg; SAR(10 g) = 0.379 W/kg

Maximum value of SAR (measured) = 1.21 W/kg

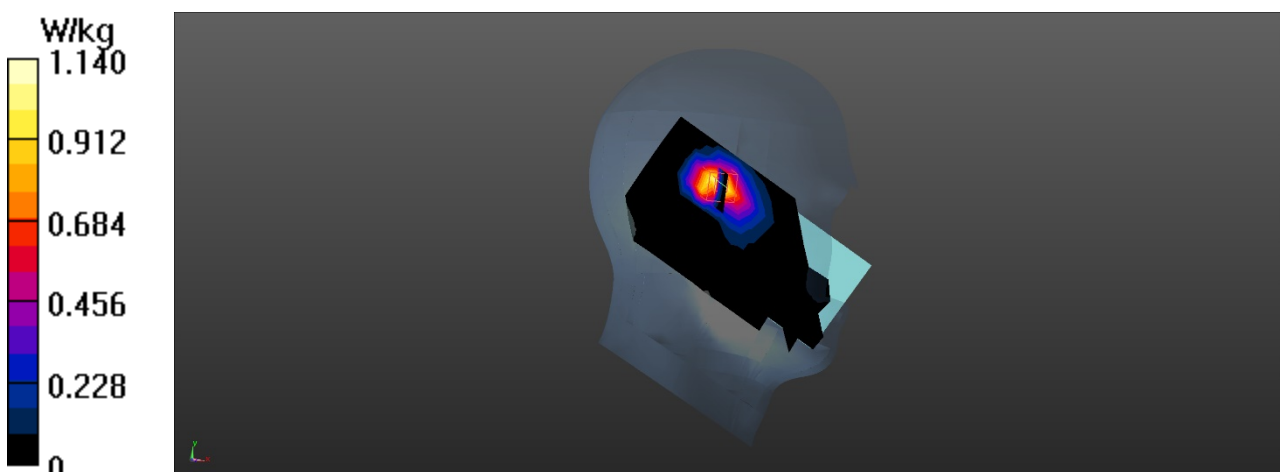

Test Laboratory: DEKRA

Date: 2022/12/10

802.11ac80M_138_Left-Check Main-Verify**DUT: Mobile Computer; Type: RS36**

Communication System: UID 0, WLAN 5G; Frequency: 5690 MHz;

Communication System PAR: 0 dB

Medium parameters used: $f = 5690$ MHz; $\sigma = 5.17$ S/m; $\epsilon_r = 34.75$; $\rho = 1000$ kg/m³

Phantom section: Left Section

Ambient Temperature (°C) : 22.8, Liquid Temperature (°C) : 21.8

Measurement Standard: DASYS (IEEE/IEC/ANSI C63.19-2011)

DASY5 Configuration:

- Probe: EX3DV4 - SN3979; ConvF(4.42, 4.42, 4.42); Calibrated: 2022/11/23;
- Sensor-Surface: 1.4mm (Mechanical Surface Detection)
- Electronics: DAE4 Sn1425; Calibrated: 2022/11/23
- Phantom: SAM with right table; Type: SAM;
- Measurement SW: DASY52, Version 52.10 (0); SEMCAD X Version 14.6.10 (7417)

Configuration/Head/Area Scan (11x21x1): Measurement grid: dx=10mm, dy=10mm

Maximum value of SAR (measured) = 2.45 W/kg

Configuration/Head/Zoom Scan (7x7x7)/Cube 0: Measurement grid: dx=4mm, dy=4mm, dz=1.4mm

Reference Value = 21.07 V/m; Power Drift = 0.01 dB

Peak SAR (extrapolated) = 4.38 W/kg

SAR(1 g) = 1.04 W/kg; SAR(10 g) = 0.336 W/kg

Maximum value of SAR (measured) = 2.59 W/kg

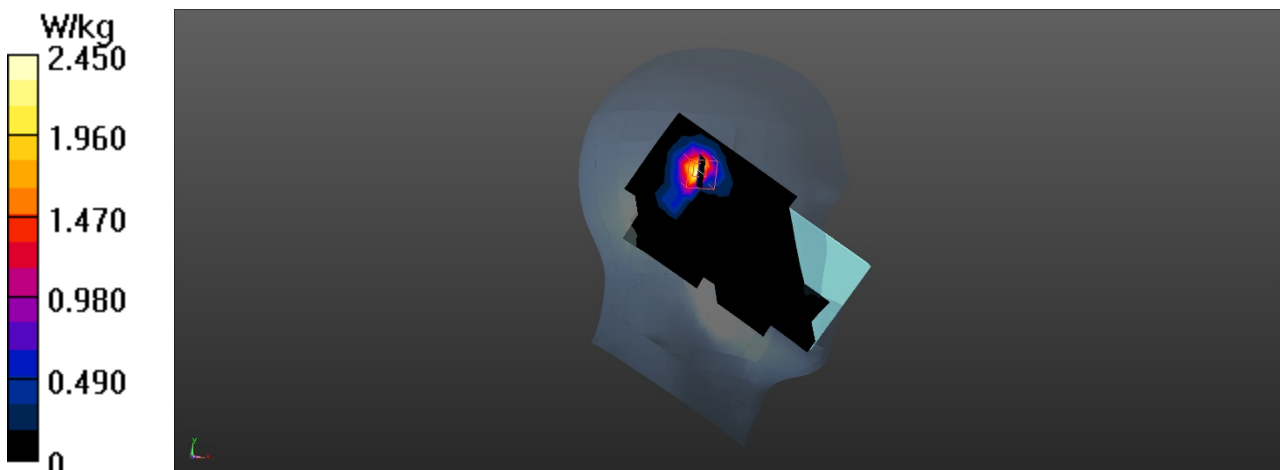

Test Laboratory: DEKRA

Date: 2022/12/27

GSM 850_4UP_Front_128_10mm-Verify**DUT: Mobile Computer; Type: RS36**

Communication System: UID 0, FCC GSM_850MHz_GPRS&EGPRS-4 Slot;

Frequency: 824.2 MHz; Communication System PAR: 3.01 dB

Medium parameters used: $f = 824.2$ MHz; $\sigma = 0.89$ S/m; $\epsilon_r = 40.95$; $\rho = 1000$ kg/m³

Phantom section: Flat Section

Ambient Temperature (°C) : 23.1, Liquid Temperature (°C) : 22.2

Measurement Standard: DASYS (IEEE/IEC/ANSI C63.19-2011)

DASY5 Configuration:

- Probe: EX3DV4 - SN3979; ConvF(10.05, 10.05, 10.05); Calibrated: 2022/11/23;
- Sensor-Surface: 1.4mm (Mechanical Surface Detection)
- Electronics: DAE4 Sn1425; Calibrated: 2022/11/23
- Phantom: SAM with right table; Type: SAM;
- Measurement SW: DASYS2, Version 52.10 (0); SEMCAD X Version 14.6.10 (7417)

Configuration/Flat/Area Scan (8x14x1): Measurement grid: dx=15mm, dy=15mm

Maximum value of SAR (measured) = 0.978 W/kg

Configuration/Flat/Zoom Scan (5x5x7)/Cube 0: Measurement grid: dx=8mm, dy=8mm, dz=5mm

Reference Value = 34.48 V/m; Power Drift = -0.00 dB

Peak SAR (extrapolated) = 1.08 W/kg

SAR(1 g) = 0.832 W/kg; SAR(10 g) = 0.631 W/kg

Maximum value of SAR (measured) = 0.995 W/kg

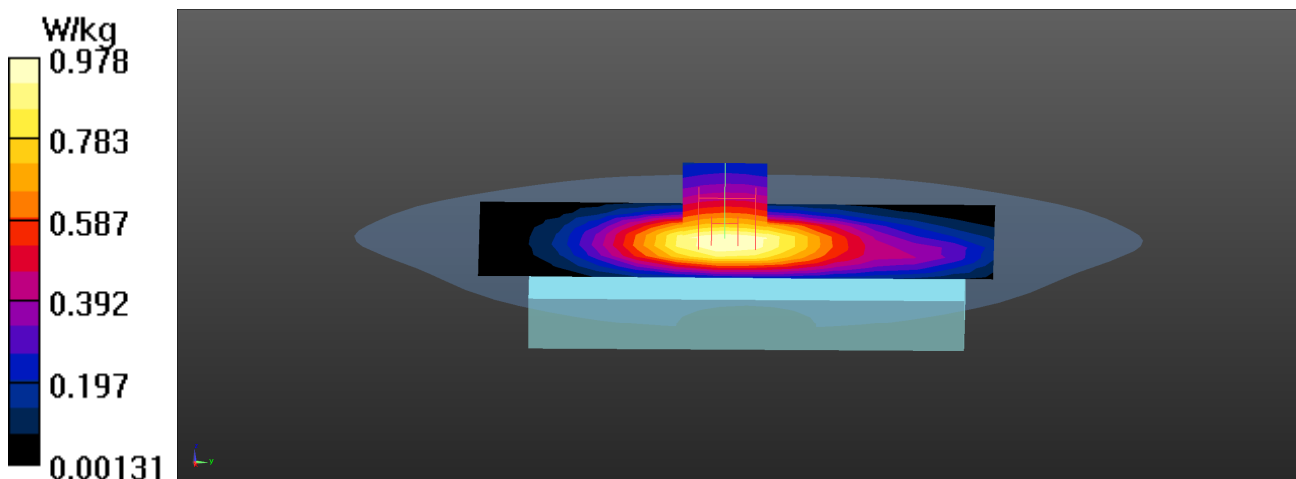

Test Laboratory: DEKRA

Date: 2022/12/27

PCS 1900_4UP_Back_512_10mm-Verify

DUT: Mobile Computer; Type: RS36

Communication System: UID 0, FCC PCS_1900MHz_GPRS&EGPRS-4 Slot;

Frequency: 1850.2 MHz; Communication System PAR: 3.01 dB

Medium parameters used: $f = 1850.2 \text{ MHz}$; $\sigma = 1.4 \text{ S/m}$; $\epsilon_r = 39.11$; $\rho = 1000 \text{ kg/m}^3$

Phantom section: Flat Section

Ambient Temperature ($^{\circ}\text{C}$) : 23.1, Liquid Temperature ($^{\circ}\text{C}$) : 22.2

Measurement Standard: DASY5 (IEEE/IEC/ANSI C63.19-2011)

DASY5 Configuration:

- Probe: EX3DV4 - SN3979; ConvF(8.12, 8.12, 8.12); Calibrated: 2022/11/23;
- Sensor-Surface: 1.4mm (Mechanical Surface Detection)
- Electronics: DAE4 Sn1425; Calibrated: 2022/11/23
- Phantom: SAM with right table; Type: SAM;
- Measurement SW: DASY52, Version 52.10 (0); SEMCAD X Version 14.6.10 (7417)

Configuration/Flat/Area Scan (8x14x1): Measurement grid: dx=15mm, dy=15mm
 Maximum value of SAR (measured) = 0.999 W/kg

Configuration/Flat/Zoom Scan (5x5x7)/Cube 0: Measurement grid: dx=8mm, dy=8mm, dz=5mm

Reference Value = 30.98 V/m; Power Drift = -0.08 dB

Peak SAR (extrapolated) = 1.70 W/kg

SAR(1 g) = 0.973 W/kg; SAR(10 g) = 0.499 W/kg

Maximum value of SAR (measured) = 1.42 W/kg

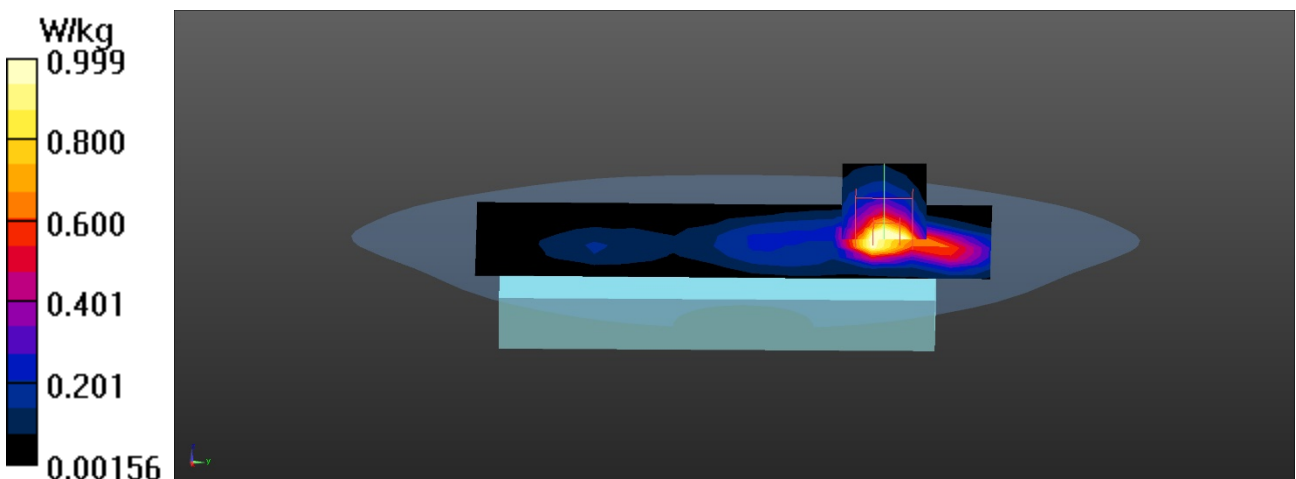

Test Laboratory: DEKRA

Date: 2022/12/17

WCDMA_BAND 2_RMC_9400_Bottom_10mm-Verify**DUT: Mobile Computer; Type: RS36**

Communication System: UID 0, FCC WCDMA_Band-2; Frequency: 1880 MHz;

Communication System PAR: 0 dB

Medium parameters used: $f = 1880$ MHz; $\sigma = 1.37$ S/m; $\epsilon_r = 40.21$; $\rho = 1000$ kg/m³

Phantom section: Flat Section

Ambient Temperature (°C) : 22.8, Liquid Temperature (°C) : 21.7

Measurement Standard: DASY5 (IEEE/IEC/ANSI C63.19-2011)

DASY5 Configuration:

- Probe: EX3DV4 - SN3979; ConvF(8.12, 8.12, 8.12); Calibrated: 2022/11/23;
- Sensor-Surface: 1.4mm (Mechanical Surface Detection)
- Electronics: DAE4 Sn1425; Calibrated: 2022/11/23
- Phantom: SAM with right table; Type: SAM;
- Measurement SW: DASY52, Version 52.10 (0); SEMCAD X Version 14.6.10 (7417)

Configuration/Flat/Area Scan (7x9x1): Measurement grid: dx=15mm, dy=15mm
Maximum value of SAR (measured) = 1.10 W/kg**Configuration/Flat/Zoom Scan (5x5x7)/Cube 0:** Measurement grid: dx=8mm, dy=8mm, dz=5mm

Reference Value = 23.16 V/m; Power Drift = 0.07 dB

Peak SAR (extrapolated) = 1.37 W/kg

SAR(1 g) = 0.806 W/kg; SAR(10 g) = 0.449 W/kg

Maximum value of SAR (measured) = 1.17 W/kg

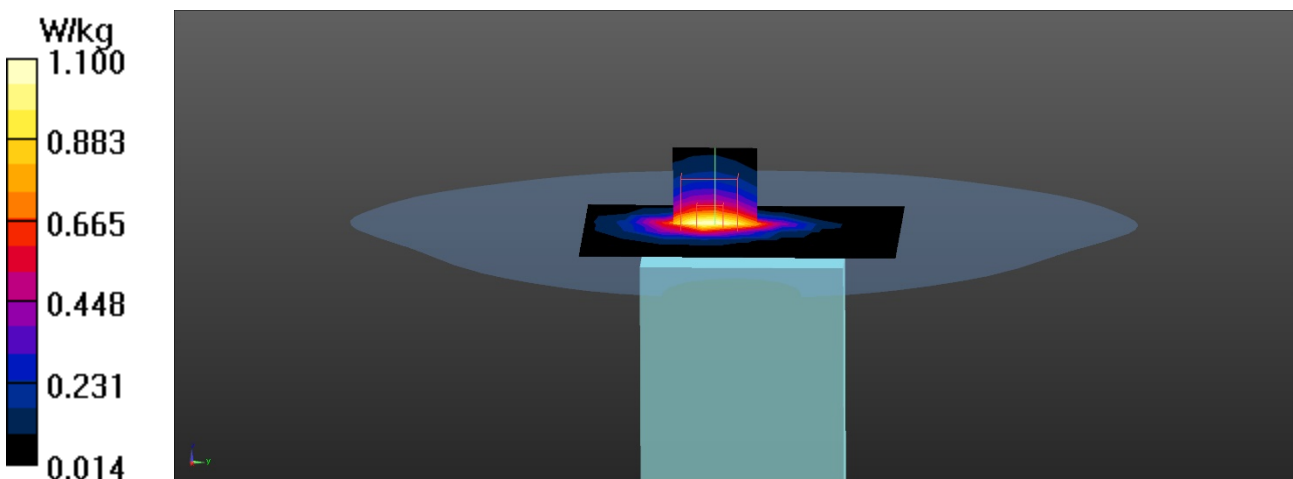

Test Laboratory: DEKRA

Date: 2022/12/27

WCDMA_BAND 4_RMC_1312_Bottom_10mm-Verify**DUT: Mobile Computer; Type: RS36**

Communication System: UID 0, FCC WCDMA_Band 4; Frequency: 1712.4 MHz;

Communication System PAR: 0 dB

Medium parameters used: $f = 1712.4$ MHz; $\sigma = 1.36$ S/m; $\epsilon_r = 39.93$; $\rho = 1000$ kg/m³

Phantom section: Flat Section

Ambient Temperature (°C) : 23.1, Liquid Temperature (°C) : 22.2

Measurement Standard: DASY5 (IEEE/IEC/ANSI C63.19-2011)

DASY5 Configuration:

- Probe: EX3DV4 - SN3979; ConvF(8.34, 8.34, 8.34); Calibrated: 2022/11/23;
- Sensor-Surface: 1.4mm (Mechanical Surface Detection)
- Electronics: DAE4 Sn1425; Calibrated: 2022/11/23
- Phantom: SAM with right table; Type: SAM;
- Measurement SW: DASY52, Version 52.10 (0); SEMCAD X Version 14.6.10 (7417)

Configuration/Head/Area Scan (8x11x1): Measurement grid: dx=15mm, dy=15mm

Maximum value of SAR (measured) = 1.22 W/kg

Configuration/Head/Zoom Scan (5x5x7)/Cube 0: Measurement grid: dx=8mm, dy=8mm, dz=5mm

Reference Value = 26.84 V/m; Power Drift = 0.08 dB

Peak SAR (extrapolated) = 1.73 W/kg

SAR(1 g) = 1.02 W/kg; SAR(10 g) = 0.582 W/kg

Maximum value of SAR (measured) = 1.48 W/kg

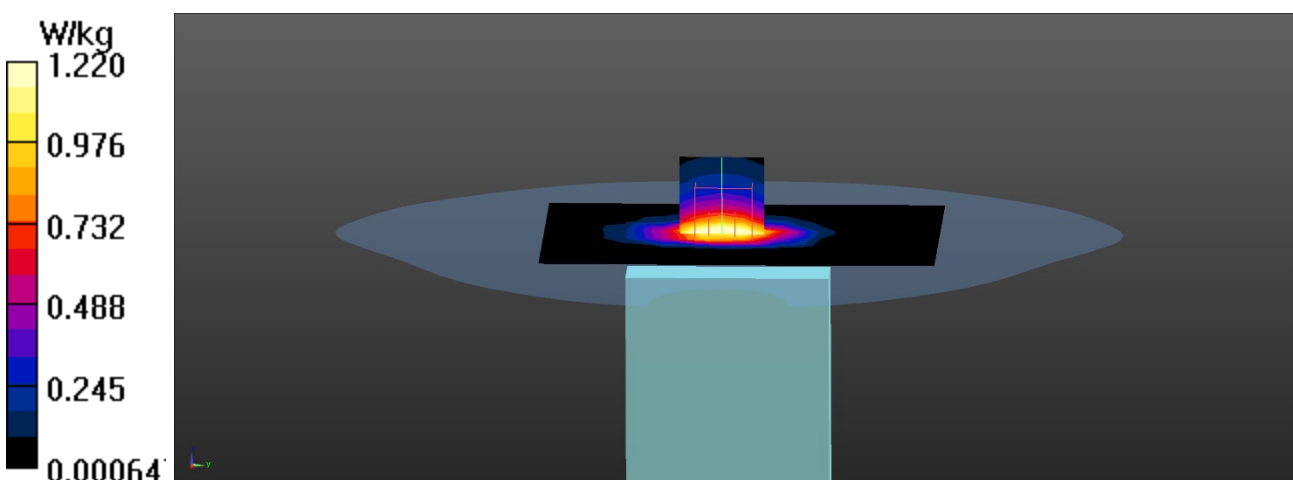

Test Laboratory: DEKRA

Date: 2022/12/17

LTE_Band7_QPSK_20M_20850_1RB-50_Bottom_10mm-Verify

DUT: Mobile Computer; Type: RS36

Communication System: UID 0, LTE Band7; Frequency: 2510 MHz;

Communication System PAR: 0 dB

Medium parameters used: $f = 2510$ MHz; $\sigma = 1.91$ S/m; $\epsilon_r = 38.97$; $\rho = 1000$ kg/m³

Phantom section: Flat Section

Ambient Temperature (°C) : 22.8, Liquid Temperature (°C) : 21.7

Measurement Standard: DASY5 (IEEE/IEC/ANSI C63.19-2011)

DASY5 Configuration:

- Probe: EX3DV4 - SN3979; ConvF(7.38, 7.38, 7.38); Calibrated: 2022/11/23;
- Sensor-Surface: 1.4mm (Mechanical Surface Detection)
- Electronics: DAE4 Sn1425; Calibrated: 2022/11/23
- Phantom: SAM with right table; Type: SAM;
- Measurement SW: DASY52, Version 52.10 (0); SEMCAD X Version 14.6.10 (7417)

Configuration/Flat/Area Scan (9x11x1): Measurement grid: dx=12mm, dy=12mm
 Maximum value of SAR (measured) = 1.11 W/kg

Configuration/Flat/Zoom Scan (7x7x7)/Cube 0: Measurement grid: dx=5mm, dy=5mm, dz=5mm

Reference Value = 27.50 V/m; Power Drift = -0.06 dB

Peak SAR (extrapolated) = 1.63 W/kg

SAR(1 g) = 0.865 W/kg; SAR(10 g) = 0.449 W/kg

Maximum value of SAR (measured) = 1.34 W/kg

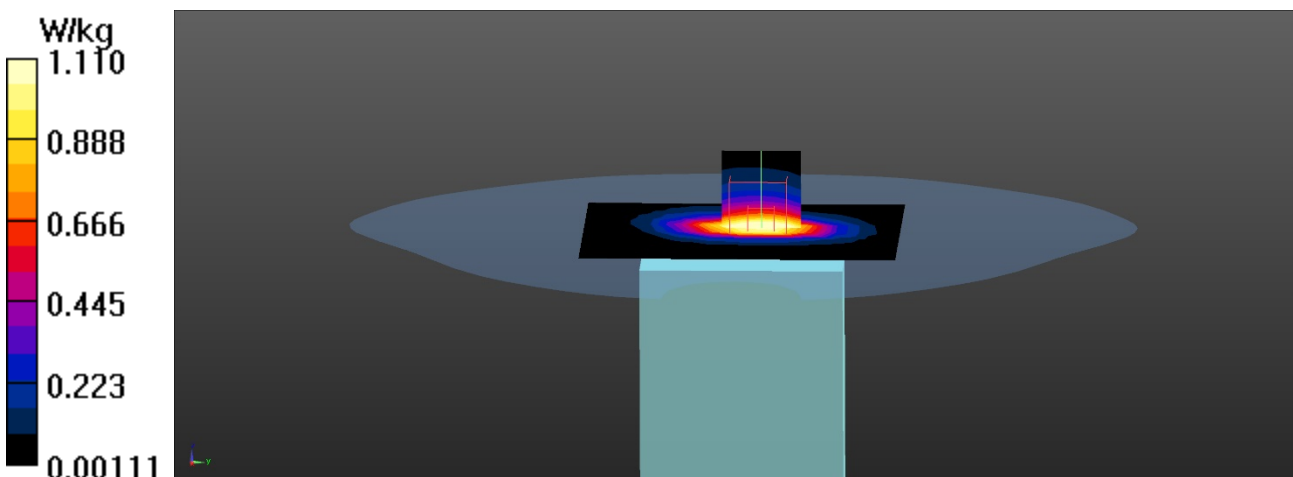

Test Laboratory: DEKRA

Date: 2022/12/17

LTE_Band25_QPSK_20M_26590_1RB-50_Bottom_10mm-Verify**DUT: Mobile Computer; Type: RS36**

Communication System: UID 0, LTE Band25; Frequency: 1905 MHz;

Communication System PAR: 0 dB

Medium parameters used: $f = 1905$ MHz; $\sigma = 1.38$ S/m; $\epsilon_r = 39.54$; $\rho = 1000$ kg/m³

Phantom section: Flat Section

Ambient Temperature (°C) : 22.8, Liquid Temperature (°C) : 21.7

Measurement Standard: DASYS (IEEE/IEC/ANSI C63.19-2011)

DASY5 Configuration:

- Probe: EX3DV4 - SN3979; ConvF(8.12, 8.12, 8.12); Calibrated: 2022/11/23;
- Sensor-Surface: 1.4mm (Mechanical Surface Detection)
- Electronics: DAE4 Sn1425; Calibrated: 2022/11/23
- Phantom: SAM with right table; Type: SAM;
- Measurement SW: DASY52, Version 52.10 (0); SEMCAD X Version 14.6.10 (7417)

Configuration/Flat/Area Scan (8x9x1): Measurement grid: dx=15mm, dy=15mm

Maximum value of SAR (measured) = 1.07 W/kg

Configuration/Flat/Zoom Scan (5x5x7)/Cube 0: Measurement grid: dx=8mm, dy=8mm, dz=5mm

Reference Value = 32.52 V/m; Power Drift = -0.07 dB

Peak SAR (extrapolated) = 1.53 W/kg

SAR(1 g) = 0.892 W/kg; SAR(10 g) = 0.497 W/kg

Maximum value of SAR (measured) = 1.31 W/kg

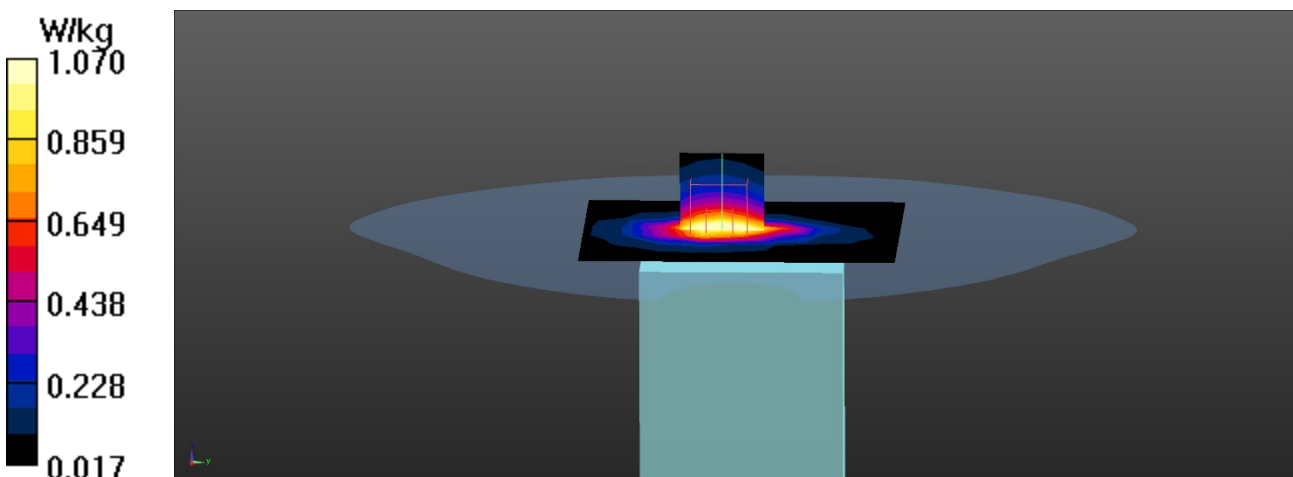



Appendix D. Probe Calibration



Accredited by the Swiss Accreditation Service (SAS)
The Swiss Accreditation Service is one of the signatories to the EA Multilateral Agreement for the recognition of calibration certificates

Accreditation No.: **SCS 0108**

Client **DEKRA (Auden)**

Certificate No **EX-3979_Nov22**

CALIBRATION CERTIFICATE

Object **EX3DV4 - SN:3979**

Calibration procedure(s) **QA CAL-01.v9, QA CAL-12.v9, QA CAL-14.v6, QA CAL-23.v5, QA CAL-25.v7
 Calibration procedure for dosimetric E-field probes**

Calibration date **November 23, 2022**

This calibration certificate documents the traceability to national standards, which realize the physical units of measurements (SI). The measurements and the uncertainties with confidence probability are given on the following pages and are part of the certificate.

All calibrations have been conducted in the closed laboratory facility: environment temperature (22 ± 3) °C and humidity < 70%.

Calibration Equipment used (M&TE critical for calibration)

Primary Standards	ID	Cal Date (Certificate No.)	Scheduled Calibration
Power meter NRP	SN: 104778	04-Apr-22 (No. 217-03525/03524)	Apr-23
Power sensor NRP-Z91	SN: 103244	04-Apr-22 (No. 217-03524)	Apr-23
OCP DAK-3.5 (weighted)	SN: 1249	20-Oct-22 (OCP-DAK3.5-1249_Oct22)	Oct-23
OCP DAK-12	SN: 1016	20-Oct-22 (OCP-DAK12-1016_Oct22)	Oct-23
Reference 20 dB Attenuator	SN: CC2552 (20x)	04-Apr-22 (No. 217-03527)	Apr-23
DAE4	SN: 660	10-Oct-22 (No. DAE4-660_Oct22)	Oct-23
Reference Probe ES3DV2	SN: 3013	27-Dec-21 (No. ES3-3013_Dec21)	Dec-22

Secondary Standards	ID	Check Date (in house)	Scheduled Check
Power meter E4419B	SN: GB41293874	06-Apr-16 (in house check Jun-22)	In house check: Jun-24
Power sensor E4412A	SN: MY41498087	06-Apr-16 (in house check Jun-22)	In house check: Jun-24
Power sensor E4412A	SN: 000110210	06-Apr-16 (in house check Jun-22)	In house check: Jun-24
RF generator HP 8648C	SN: US3642U01700	04-Aug-99 (in house check Jun-22)	In house check: Jun-24
Network Analyzer E8358A	SN: US41080477	31-Mar-14 (in house check Oct-22)	In house check: Oct-24

	Name	Function	Signature
Calibrated by	Jeffrey Katzman	Laboratory Technician	
Approved by	Sven Kühn	Technical Manager	

Issued: November 23, 2022

This calibration certificate shall not be reproduced except in full without written approval of the laboratory.

Calibration Laboratory of

Schmid & Partner
Engineering AG

Zeughausstrasse 43, 8004 Zurich, Switzerland



S Schweizerischer Kalibrierdienst
C Service suisse d'étalonnage
S Servizio svizzero di taratura
S Swiss Calibration Service

Accredited by the Swiss Accreditation Service (SAS)

The Swiss Accreditation Service is one of the signatories to the EA
Multilateral Agreement for the recognition of calibration certificates

Accreditation No.: **SCS 0108**

Glossary

TSL	tissue simulating liquid
NORM _{x,y,z}	sensitivity in free space
ConvF	sensitivity in TSL / NORM _{x,y,z}
DCP	diode compression point
CF	crest factor (1/duty_cycle) of the RF signal
A, B, C, D	modulation dependent linearization parameters
Polarization φ	φ rotation around probe axis
Polarization ϑ	ϑ rotation around an axis that is in the plane normal to probe axis (at measurement center), i.e., $\vartheta = 0$ is normal to probe axis
Connector Angle	information used in DASY system to align probe sensor X to the robot coordinate system

Calibration is Performed According to the Following Standards:

- IEC/IEEE 62209-1528, "Measurement Procedure For The Assessment Of Specific Absorption Rate Of Human Exposure To Radio Frequency Fields From Hand-Held And Body-Worn Wireless Communication Devices – Part 1528: Human Models, Instrumentation And Procedures (Frequency Range of 4 MHz to 10 GHz)", October 2020.
- KDB 865664, "SAR Measurement Requirements for 100 MHz to 6 GHz"

Methods Applied and Interpretation of Parameters:

- NORM_{x,y,z}**: Assessed for E-field polarization $\vartheta = 0$ ($f \leq 900$ MHz in TEM-cell; $f > 1800$ MHz: R22 waveguide). NORM_{x,y,z} are only intermediate values, i.e., the uncertainties of NORM_{x,y,z} does not affect the E²-field uncertainty inside TSL (see below ConvF).
- NORM(f)_{x,y,z} = NORM_{x,y,z} * frequency_response** (see Frequency Response Chart). This linearization is implemented in DASY4 software versions later than 4.2. The uncertainty of the frequency response is included in the stated uncertainty of ConvF.
- DCP_{x,y,z}**: DCP are numerical linearization parameters assessed based on the data of power sweep with CW signal. DCP does not depend on frequency nor media.
- PAR**: PAR is the Peak to Average Ratio that is not calibrated but determined based on the signal characteristics
- A_{x,y,z}; B_{x,y,z}; C_{x,y,z}; D_{x,y,z}; VR_{x,y,z}**: A, B, C, D are numerical linearization parameters assessed based on the data of power sweep for specific modulation signal. The parameters do not depend on frequency nor media. VR is the maximum calibration range expressed in RMS voltage across the diode.
- ConvF and Boundary Effect Parameters**: Assessed in flat phantom using E-field (or Temperature Transfer Standard for $f \leq 800$ MHz) and inside waveguide using analytical field distributions based on power measurements for $f > 800$ MHz. The same setups are used for assessment of the parameters applied for boundary compensation (alpha, depth) of which typical uncertainty values are given. These parameters are used in DASY4 software to improve probe accuracy close to the boundary. The sensitivity in TSL corresponds to NORM_{x,y,z} * ConvF whereby the uncertainty corresponds to that given for ConvF. A frequency dependent ConvF is used in DASY version 4.4 and higher which allows extending the validity from ± 50 MHz to ± 100 MHz.
- Spherical isotropy (3D deviation from isotropy)**: in a field of low gradients realized using a flat phantom exposed by a patch antenna.
- Sensor Offset**: The sensor offset corresponds to the offset of virtual measurement center from the probe tip (on probe axis). No tolerance required.
- Connector Angle**: The angle is assessed using the information gained by determining the NORM_x (no uncertainty required).

Parameters of Probe: EX3DV4 - SN:3979

Basic Calibration Parameters

	Sensor X	Sensor Y	Sensor Z	Unc (k = 2)
Norm ($\mu\text{V}/(\text{V}/\text{m})^2$) ^A	0.46	0.49	0.47	$\pm 10.1\%$
DCP (mV) ^B	103.0	101.0	103.4	$\pm 4.7\%$

Calibration Results for Modulation Response

UID	Communication System Name		A dB	B dB $\sqrt{\mu\text{V}}$	C	D dB	VR mV	Max dev.	Max Unc ^E k = 2
0	CW	X	0.00	0.00	1.00	0.00	163.8	$\pm 1.7\%$	$\pm 4.7\%$
		Y	0.00	0.00	1.00		165.4		
		Z	0.00	0.00	1.00		158.1		

The reported uncertainty of measurement is stated as the standard uncertainty of measurement multiplied by the coverage factor k=2, which for a normal distribution corresponds to a coverage probability of approximately 95%.

^A The uncertainties of Norm X,Y,Z do not affect the E²-field uncertainty inside TSL (see Page 5).

^B Linearization parameter uncertainty for maximum specified field strength.

^E Uncertainty is determined using the max. deviation from linear response applying rectangular distribution and is expressed for the square of the field value.

Parameters of Probe: EX3DV4 - SN:3979**Other Probe Parameters**

Sensor Arrangement	Triangular
Connector Angle	136.0°
Mechanical Surface Detection Mode	enabled
Optical Surface Detection Mode	disabled
Probe Overall Length	337 mm
Probe Body Diameter	10 mm
Tip Length	9 mm
Tip Diameter	2.5 mm
Probe Tip to Sensor X Calibration Point	1 mm
Probe Tip to Sensor Y Calibration Point	1 mm
Probe Tip to Sensor Z Calibration Point	1 mm
Recommended Measurement Distance from Surface	1.4 mm

Note: Measurement distance from surface can be increased to 3–4 mm for an *Area Scan* job.

Parameters of Probe: EX3DV4 - SN:3979

Calibration Parameter Determined in Head Tissue Simulating Media

f (MHz) ^C	Relative Permittivity ^F	Conductivity ^F (S/m)	ConvF X	ConvF Y	ConvF Z	Alpha ^G	Depth ^G (mm)	Unc (k = 2)
450	43.5	0.87	10.79	10.79	10.79	0.16	1.30	±13.3%
750	41.9	0.89	10.47	10.47	10.47	0.54	0.80	±12.0%
835	41.5	0.90	10.05	10.05	10.05	0.53	0.80	±12.0%
900	41.5	0.97	9.73	9.73	9.73	0.49	0.80	±12.0%
1450	40.5	1.20	8.47	8.47	8.47	0.54	0.80	±12.0%
1640	40.2	1.31	8.48	8.48	8.48	0.38	0.86	±12.0%
1750	40.1	1.37	8.34	8.34	8.34	0.35	0.86	±12.0%
1950	40.0	1.40	8.12	8.12	8.12	0.39	0.86	±12.0%
2300	39.5	1.67	7.87	7.87	7.87	0.31	0.90	±12.0%
2450	39.2	1.80	7.58	7.58	7.58	0.34	0.90	±12.0%
2600	39.0	1.96	7.38	7.38	7.38	0.41	0.90	±12.0%
3300	38.2	2.71	6.92	6.92	6.92	0.40	1.30	±13.1%
3500	37.9	2.91	6.85	6.85	6.85	0.40	1.30	±13.1%
3700	37.7	3.12	6.82	6.82	6.82	0.35	1.30	±13.1%
5250	35.9	4.71	4.80	4.80	4.80	0.40	1.80	±13.1%
5600	35.5	5.07	4.42	4.42	4.42	0.40	1.80	±13.1%
5800	35.3	5.27	4.40	4.40	4.40	0.40	1.80	±13.1%

^C Frequency validity above 300 MHz of ±100 MHz only applies for DASY v4.4 and higher (see Page 2), else it is restricted to ±50 MHz. The uncertainty is the RSS of the ConvF uncertainty at calibration frequency and the uncertainty for the indicated frequency band. Frequency validity below 300 MHz is ±10, 25, 40, 50 and 70 MHz for ConvF assessments at 30, 64, 128, 150 and 220 MHz respectively. Validity of ConvF assessed at 6 MHz is 4–9 MHz, and ConvF assessed at 13 MHz is 9–19 MHz. Above 5 GHz frequency validity can be extended to ±110 MHz.

^F At frequencies below 3 GHz, the validity of tissue parameters (ϵ and σ) can be relaxed to ±10% if liquid compensation formula is applied to measured SAR values. At frequencies above 3 GHz, the validity of tissue parameters (ϵ and σ) is restricted to ±5%. The uncertainty is the RSS of the ConvF uncertainty for indicated target tissue parameters.

^G Alpha/Depth are determined during calibration. SPEAG warrants that the remaining deviation due to the boundary effect after compensation is always less than ±1% for frequencies below 3 GHz and below ±2% for frequencies between 3–6 GHz at any distance larger than half the probe tip diameter from the boundary.

Frequency Response of E-Field (TEM-Cell:ifi110 EXX, Waveguide:R22)

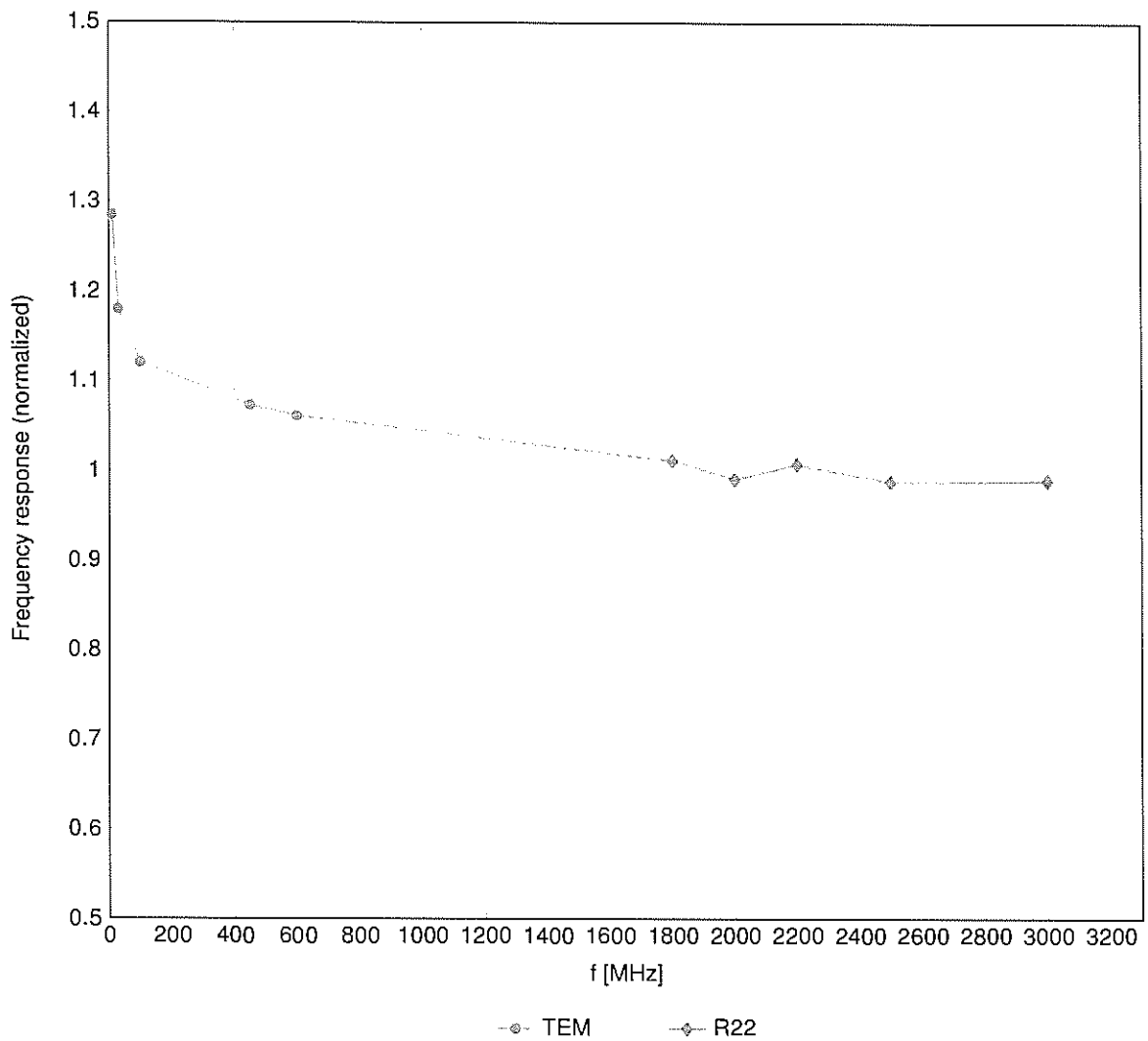

Uncertainty of Frequency Response of E-field: $\pm 6.3\%$ (k=2)

Receiving Pattern (ϕ), $\vartheta = 0^\circ$

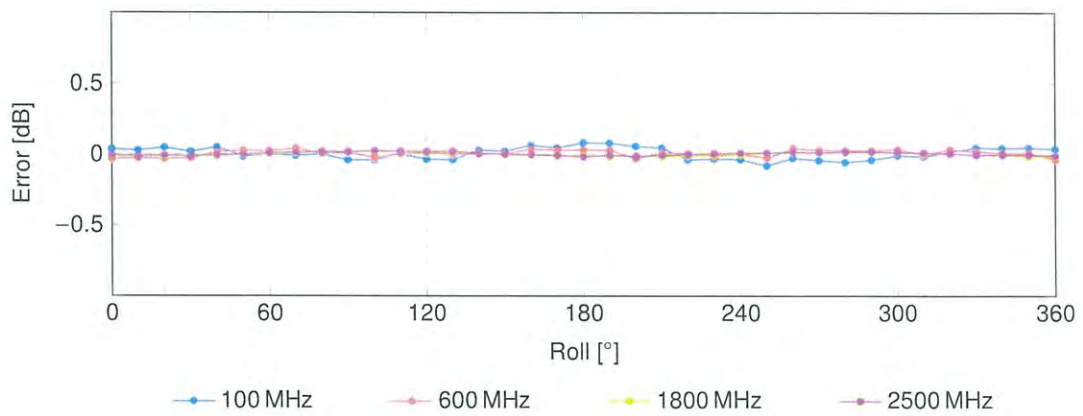
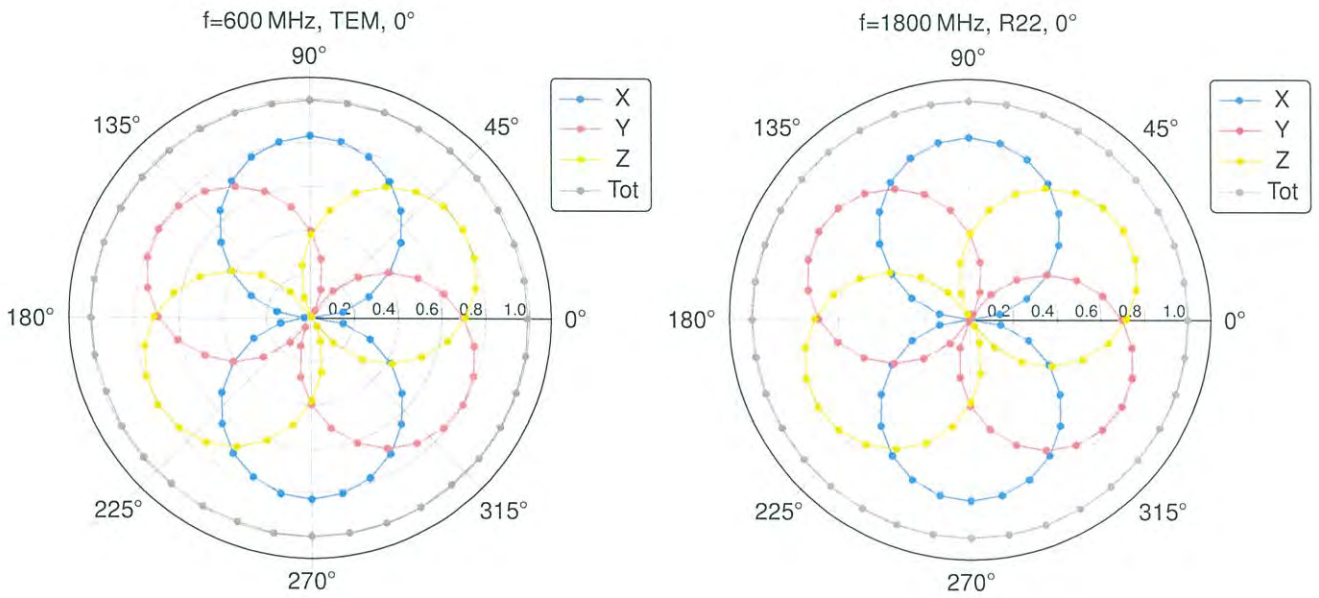

Uncertainty of Axial Isotropy Assessment: $\pm 0.5\%$ ($k=2$)

Dynamic Range f(SAR_{head})

(TEM cell, f_{eval} = 1900 MHz)

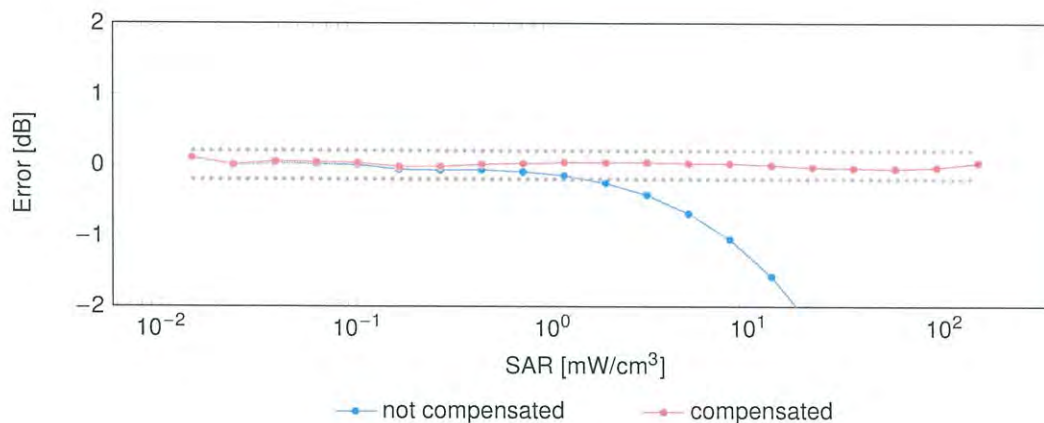
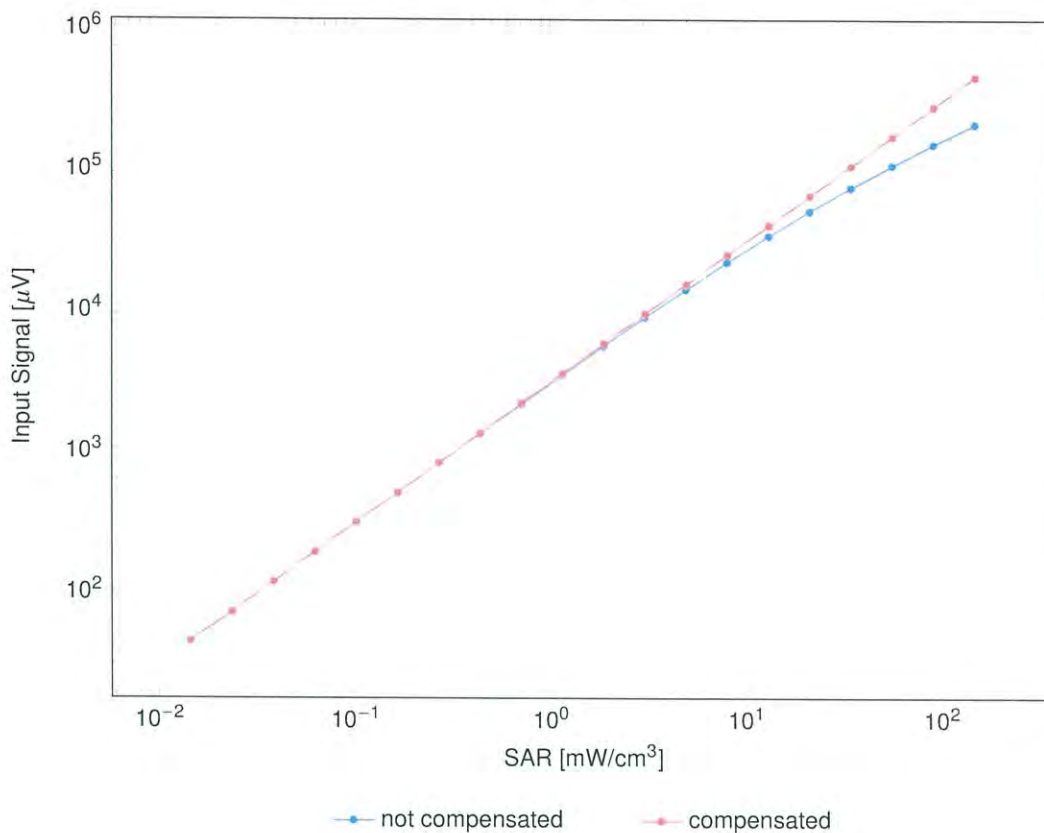

Uncertainty of Linearity Assessment: ±0.6% (k=2)

Conversion Factor Assessment

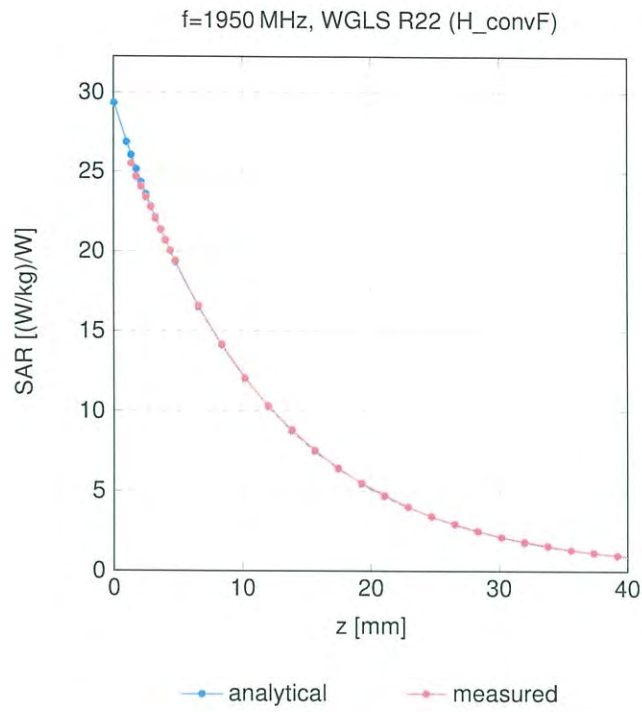

Deviation from Isotropy in Liquid

Error (ϕ, θ), f = 900 MHz

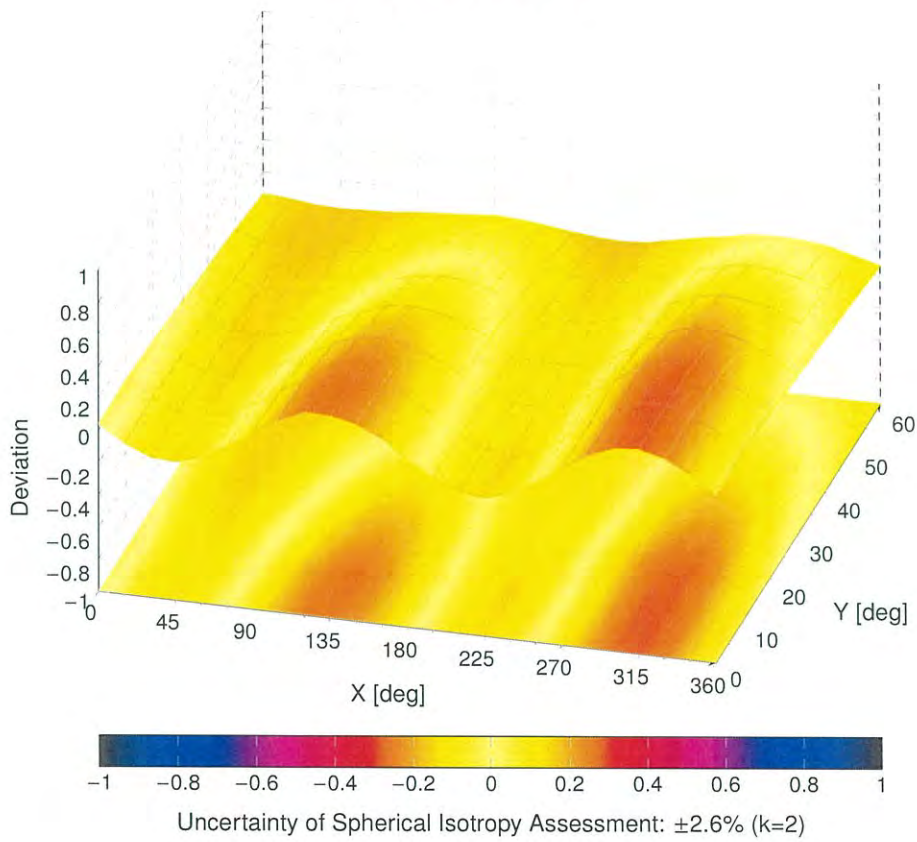



Accredited by the Swiss Accreditation Service (SAS)
The Swiss Accreditation Service is one of the signatories to the EA
Multilateral Agreement for the recognition of calibration certificates

Accreditation No.: **SCS 0108**

Client **DEKRA (Auden)**

Certificate No: **D750V3-1031_May20**

CALIBRATION CERTIFICATE

Object **D750V3 - SN:1031**

Calibration procedure(s) **QA CAL-05.v11
Calibration Procedure for SAR Validation Sources between 0.7-3 GHz**

Calibration date: **May 27, 2020**

This calibration certificate documents the traceability to national standards, which realize the physical units of measurements (SI).
The measurements and the uncertainties with confidence probability are given on the following pages and are part of the certificate.

All calibrations have been conducted in the closed laboratory facility: environment temperature (22 ± 3)°C and humidity < 70%.

Calibration Equipment used (M&TE critical for calibration)

Primary Standards	ID #	Cal Date (Certificate No.)	Scheduled Calibration
Power meter NRP	SN: 104778	01-Apr-20 (No. 217-03100/03101)	Apr-21
Power sensor NRP-Z91	SN: 103244	01-Apr-20 (No. 217-03100)	Apr-21
Power sensor NRP-Z91	SN: 103245	01-Apr-20 (No. 217-03101)	Apr-21
Reference 20 dB Attenuator	SN: BH9394 (20k)	31-Mar-20 (No. 217-03106)	Apr-21
Type-N mismatch combination	SN: 310982 / 06327	31-Mar-20 (No. 217-03104)	Apr-21
Reference Probe EX3DV4	SN: 7349	31-Dec-19 (No. EX3-7349_Dec19)	Dec-20
DAE4	SN: 601	27-Dec-19 (No. DAE4-601_Dec19)	Dec-20
Secondary Standards	ID #	Check Date (in house)	Scheduled Check
Power meter E4419B	SN: GB39512475	30-Oct-14 (in house check Feb-19)	In house check: Oct-20
Power sensor HP 8481A	SN: US37292783	07-Oct-15 (in house check Oct-18)	In house check: Oct-20
Power sensor HP 8481A	SN: MY41092317	07-Oct-15 (in house check Oct-18)	In house check: Oct-20
RF generator R&S SMT-06	SN: 100972	15-Jun-15 (in house check Oct-18)	In house check: Oct-20
Network Analyzer Agilent E8358A	SN: US41080477	31-Mar-14 (in house check Oct-19)	In house check: Oct-20

	Name	Function	Signature
Calibrated by:	Jeffrey Katzman	Laboratory Technician	
Approved by:	Katja Pokovic	Technical Manager	

Issued: May 27, 2020

This calibration certificate shall not be reproduced except in full without written approval of the laboratory.



Accredited by the Swiss Accreditation Service (SAS)

The Swiss Accreditation Service is one of the signatories to the EA
Multilateral Agreement for the recognition of calibration certificates

Accreditation No.: **SCS 0108**

Glossary:

TSL	tissue simulating liquid
ConvF	sensitivity in TSL / NORM x,y,z
N/A	not applicable or not measured

Calibration is Performed According to the Following Standards:

- IEEE Std 1528-2013, "IEEE Recommended Practice for Determining the Peak Spatial-Averaged Specific Absorption Rate (SAR) in the Human Head from Wireless Communications Devices: Measurement Techniques", June 2013
- IEC 62209-1, "Measurement procedure for the assessment of Specific Absorption Rate (SAR) from hand-held and body-mounted devices used next to the ear (frequency range of 300 MHz to 6 GHz)", July 2016
- IEC 62209-2, "Procedure to determine the Specific Absorption Rate (SAR) for wireless communication devices used in close proximity to the human body (frequency range of 30 MHz to 6 GHz)", March 2010
- KDB 865664, "SAR Measurement Requirements for 100 MHz to 6 GHz"

Additional Documentation:

- DASY4/5 System Handbook

Methods Applied and Interpretation of Parameters:

- Measurement Conditions:** Further details are available from the Validation Report at the end of the certificate. All figures stated in the certificate are valid at the frequency indicated.
- Antenna Parameters with TSL:** The dipole is mounted with the spacer to position its feed point exactly below the center marking of the flat phantom section, with the arms oriented parallel to the body axis.
- Feed Point Impedance and Return Loss:** These parameters are measured with the dipole positioned under the liquid filled phantom. The impedance stated is transformed from the measurement at the SMA connector to the feed point. The Return Loss ensures low reflected power. No uncertainty required.
- Electrical Delay:** One-way delay between the SMA connector and the antenna feed point. No uncertainty required.
- SAR measured:** SAR measured at the stated antenna input power.
- SAR normalized:** SAR as measured, normalized to an input power of 1 W at the antenna connector.
- SAR for nominal TSL parameters:** The measured TSL parameters are used to calculate the nominal SAR result.

The reported uncertainty of measurement is stated as the standard uncertainty of measurement multiplied by the coverage factor $k=2$, which for a normal distribution corresponds to a coverage probability of approximately 95%.