

OCC B66 20M CH132322 QPSK

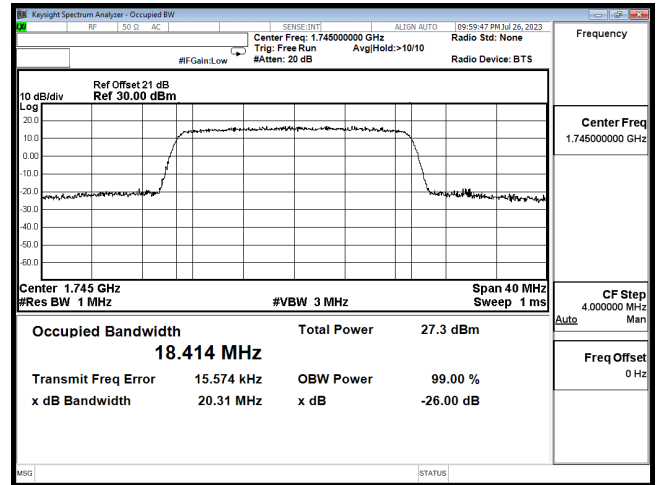

OCC B66 20M CH132322 16QAM

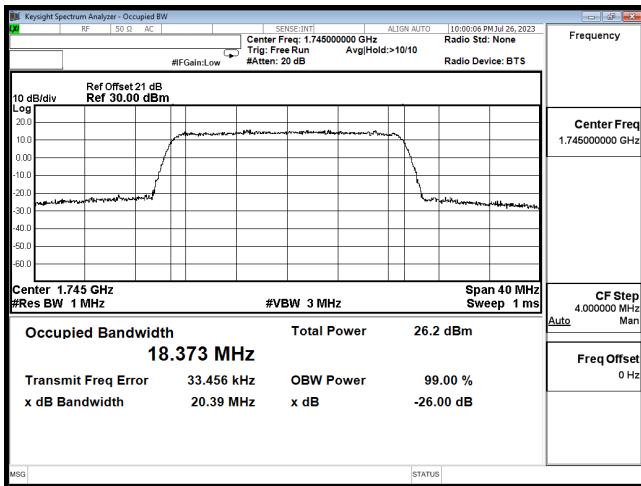

OCC B66 20M CH132322 64QAM

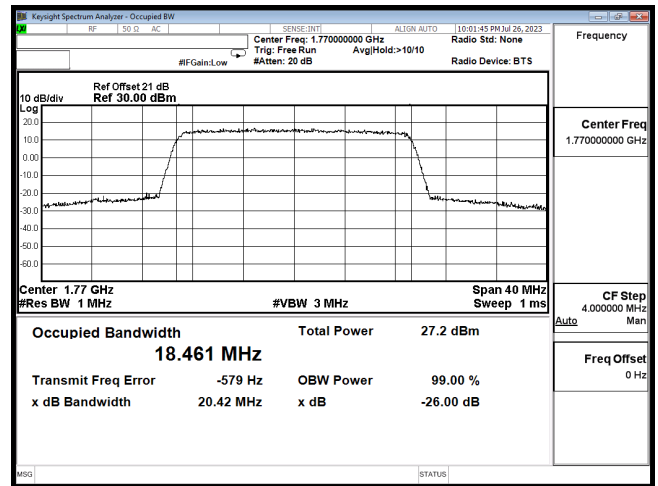

OCC B66 20M CH132572 QPSK

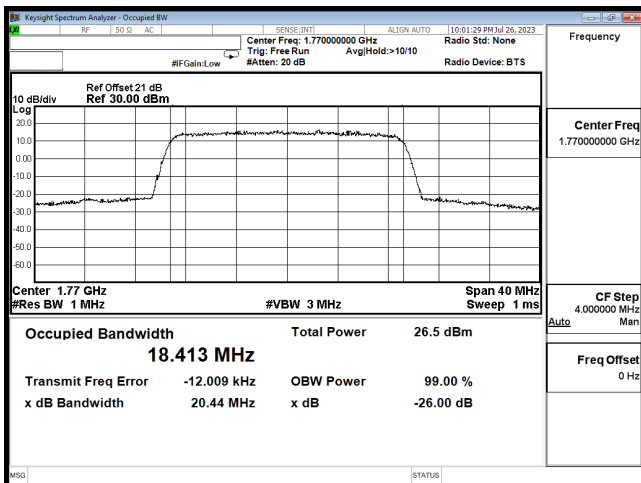

OCC B66 20M CH132572 16QAM

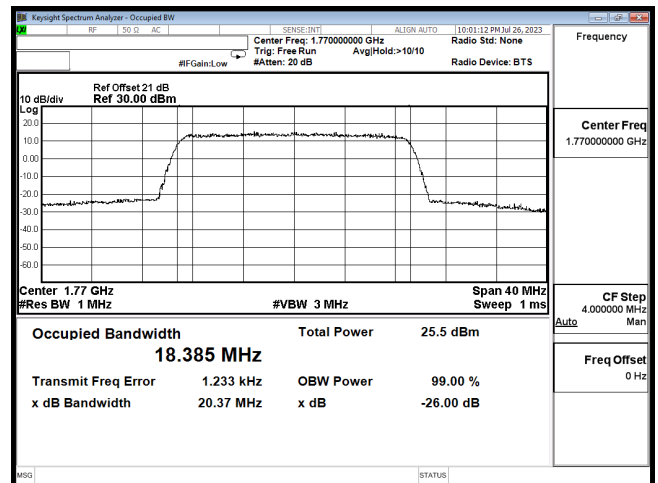

OCC B66 20M CH132572 64QAM

## 5. Spurious Emission At Antenna Terminals (+/-1MHz)

### 5.1 Test Specification

According to Part 2.1051, 22.917, 24.238, 27.53, RSS-GEN, RSS-130, RSS-132, RSS-133, RSS-139, RSS-199.

### 5.2 Setup

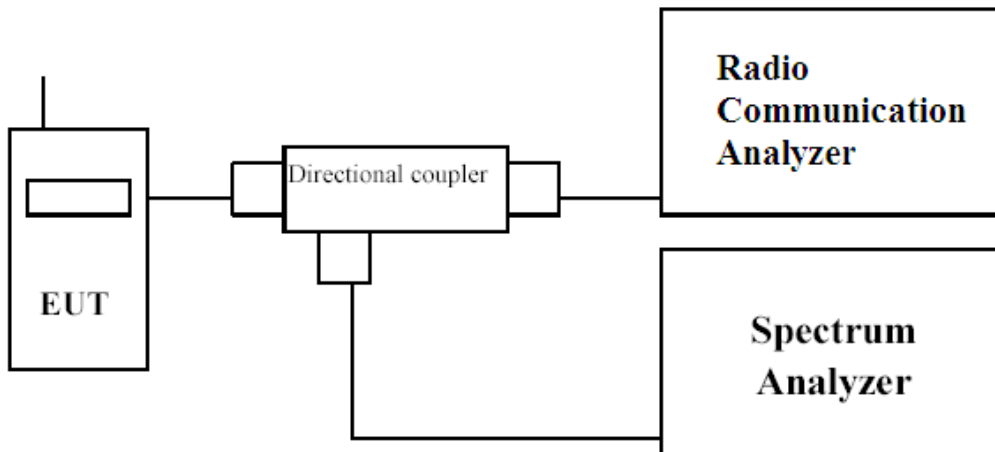

### 5.3 Limits

The spurious (unwanted) emission limits specified in the individual FCC rule parts applicable to licensed digital transmitters (typically referred to under the heading ‘emission limits’) normally apply to any and all emissions that are present outside of the authorized frequency band/block and apply to emissions in both the out-of-band and spurious domains. unwanted emissions are required by the licensed rule parts to be attenuated below the transmitter power by a factor of at least  $43 + 10 \log (P)$  dB, where P represents the transmitter power expressed in watts

For LTE Band 13:

On all frequencies between 763-775 MHz and 793-805 MHz, by a factor not less than  $65 + 10 \log (P)$  dB in a 6.25 kHz band segment, for mobile and portable stations

For LTE Band 7/38/41:

27.53(m) For mobile digital stations, the attenuation factor shall be not less than  $40 + 10 \log (P)$  dB on all frequencies between the channel edge and 5 megahertz from the channel edge,  $43 + 10 \log (P)$  dB on all frequencies between 5 megahertz and X megahertz from the channel edge, and  $55 + 10 \log (P)$  dB on all frequencies more than X megahertz from the channel edge, where X is the greater of 6 megahertz or the actual emission bandwidth as defined in paragraph (m)(6) of this section. In addition, the attenuation factor shall not be less than  $43 + 10 \log (P)$  dB on all frequencies between 2490.5 MHz and 2496 MHz and  $55 + 10 \log (P)$  dB at or below 2490.5 MHz. Mobile Satellite Service licensees operating on frequencies below 2495 MHz may also submit a documented interference complaint against BRS licensees operating on channel BRS Channel 1 on the same terms and conditions as adjacent channel BRS or EBS licensees.

#### 5.4 Test Procedure

In accordance with Part 22.917, 24.238, 27.53 at least 1 % of the emission bandwidth was used for the resolution and video bandwidths up to 1 MHz away from the Block Edge. At greater than 1 MHz, the resolution and video bandwidth were increased to 1 MHz / 3 MHz.

The reference power and path losses of all channels used for testing in each frequency block were measured.

### 5.5 Test Result of Spurious Emission At Antenna Terminals (+/-1MHz)

#### LTE Band 7

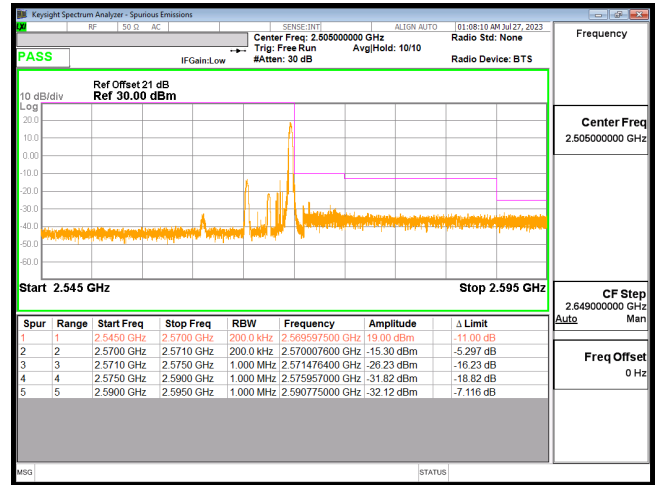
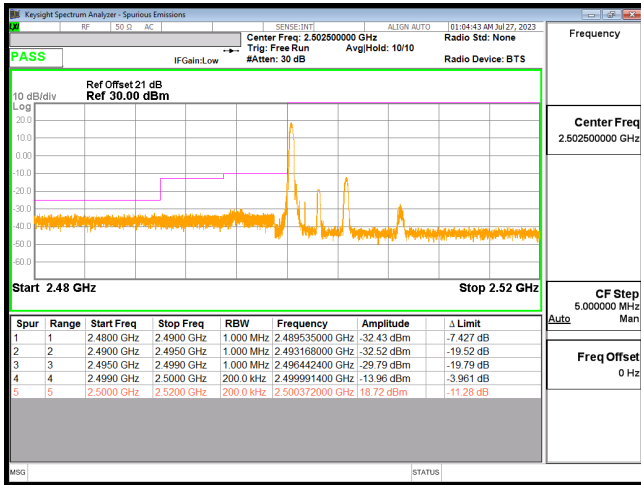

Bandedge B7 5M CH20775 QPSK(1,0)

Bandedge B7 5M CH21425 QPSK(1,24)

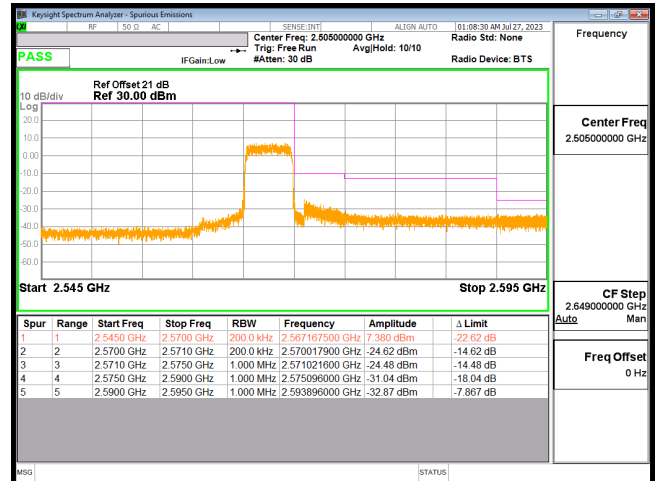
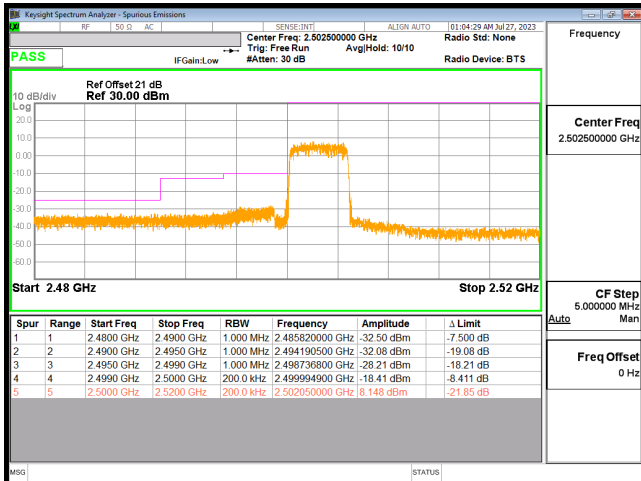

Bandedge B7 5M CH20775 QPSK(25,0)

Bandedge B7 5M CH21425 QPSK(25,0)

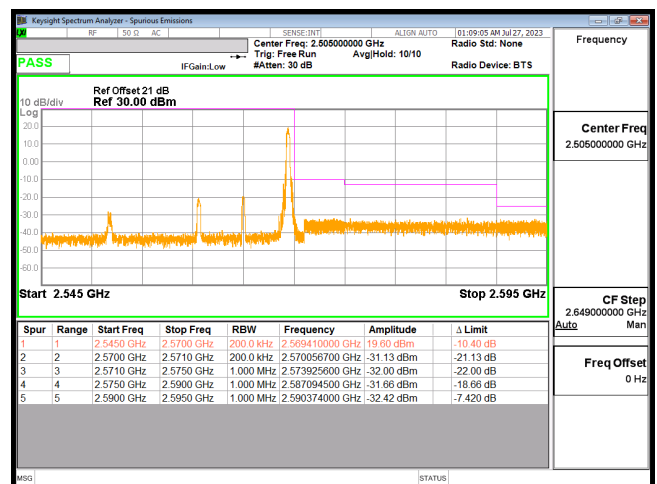
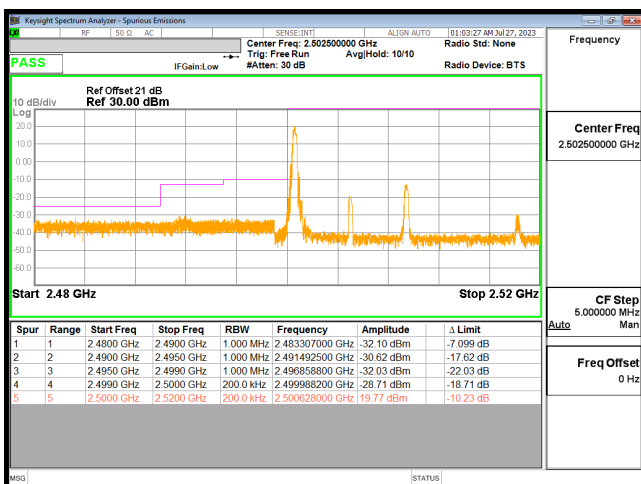

Bandedge B7 10M CH20800 QPSK(1,0)

Bandedge B7 10M CH21400 QPSK(1,49)

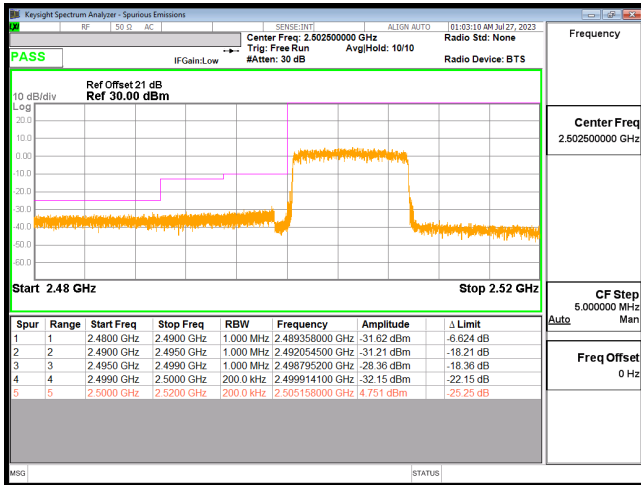

Bandedge B7 10M CH20800 QPSK(50,0)

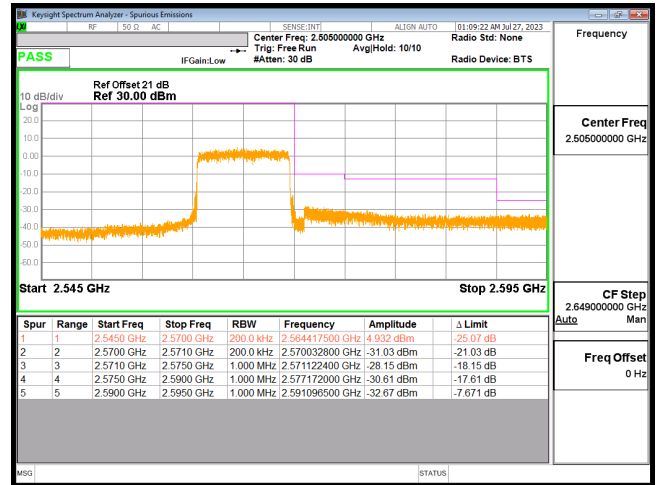

Bandedge B7 10M CH21400 QPSK(50,0)

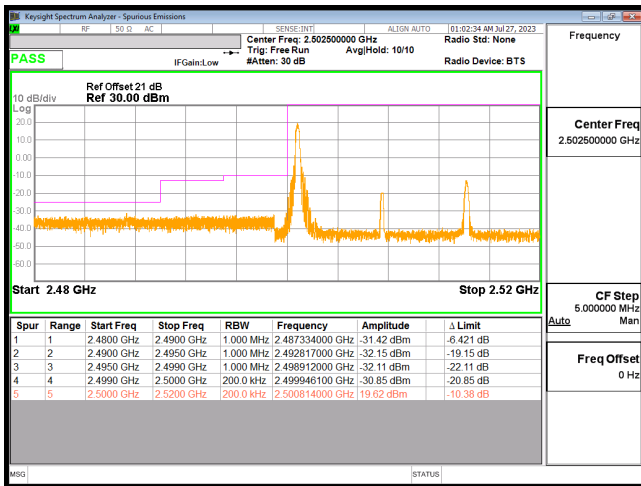

Bandedge B7 15M CH20825 QPSK(1,0)

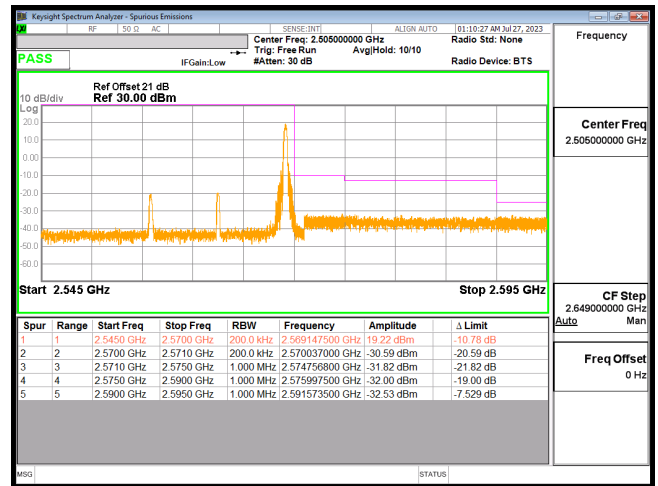

Bandedge B7 15M CH21375 QPSK(1,74)



Bandedge B7 15M CH20825 QPSK(75,0)



Bandedge B7 15M CH21375 QPSK(75,0)

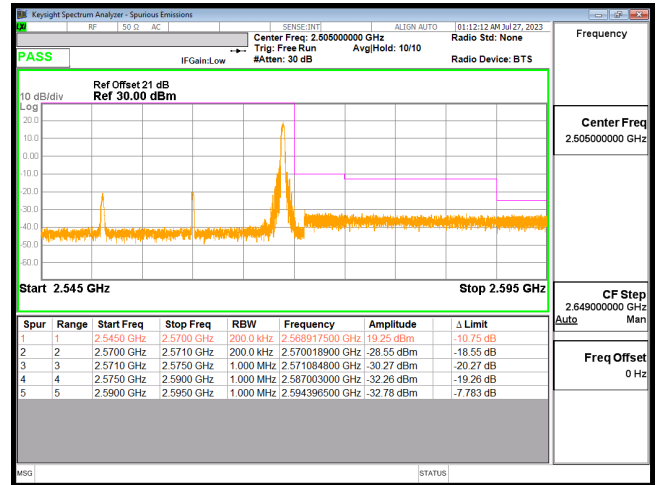
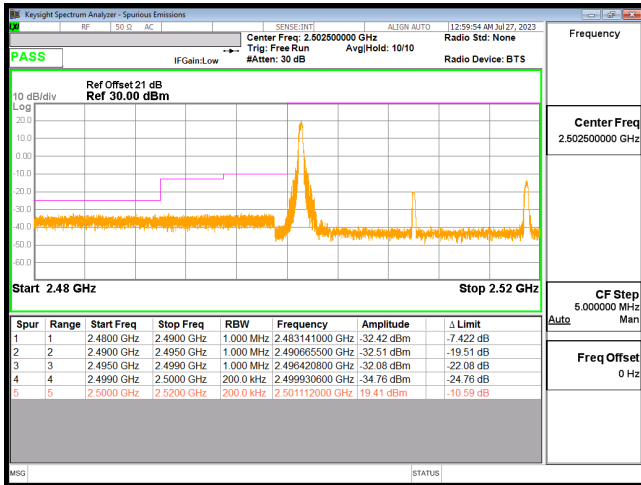

Bandedge B7 20M CH20850 QPSK(1,0)

Bandedge B7 20M CH21350 QPSK(1,99)

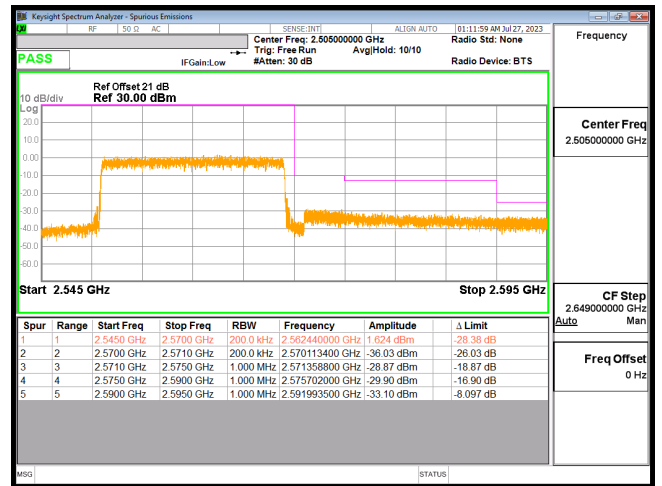
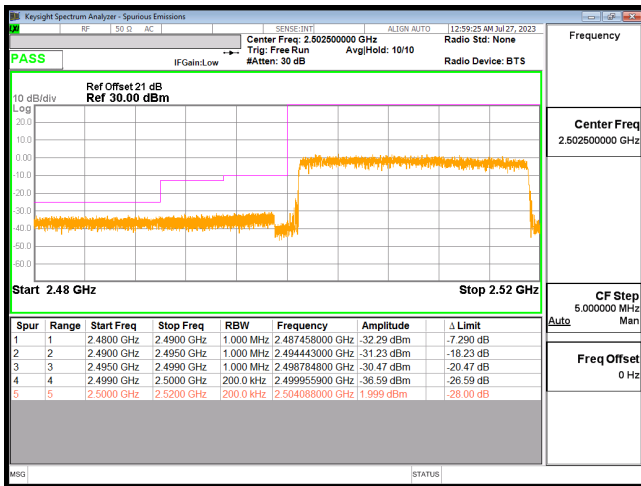

Bandedge B7 20M CH20850 QPSK(100,0)

Bandedge B7 20M CH21350 QPSK(100,0)

LTE Band 12

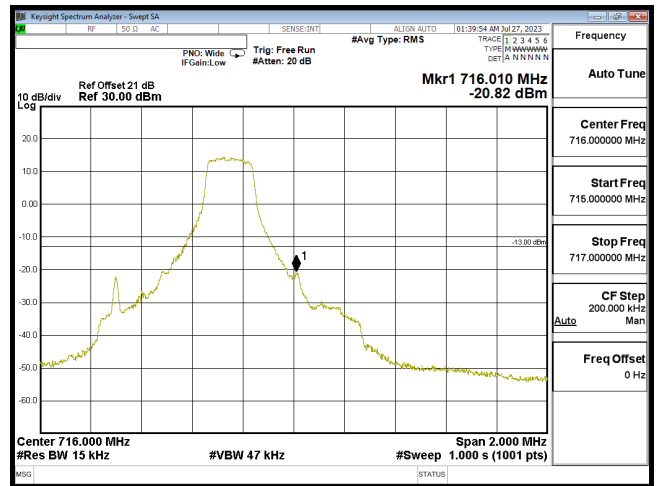
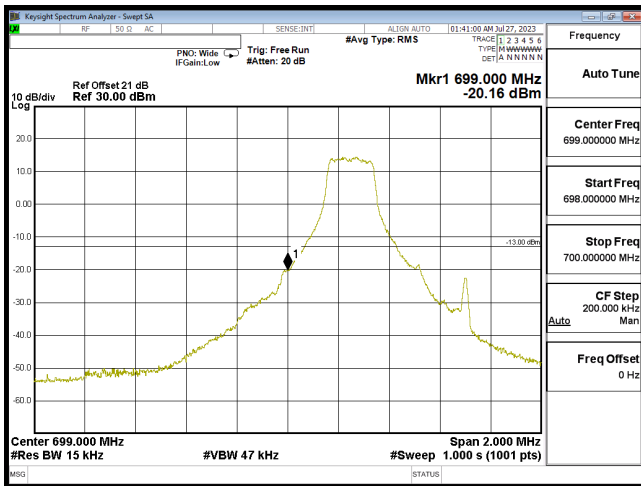

Bandedge B12 1.4M CH23017 QPSK(1,0)

Bandedge B12 1.4M CH23173 QPSK(1,5)

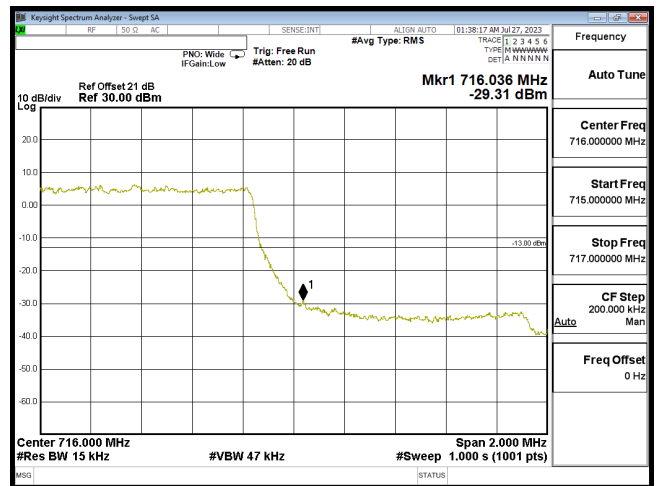
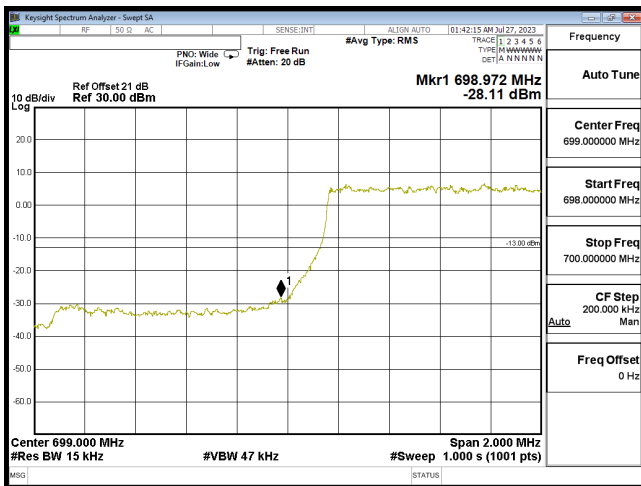

Bandedge B12 1.4M CH23017 QPSK(6,0)

Bandedge B12 1.4M CH23173 QPSK(6,0)

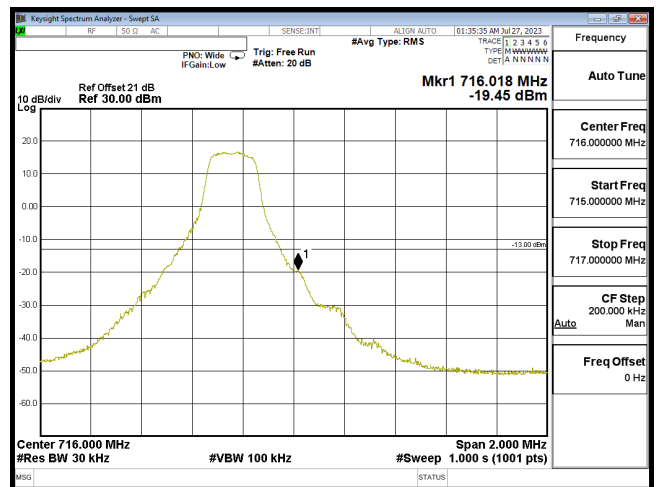
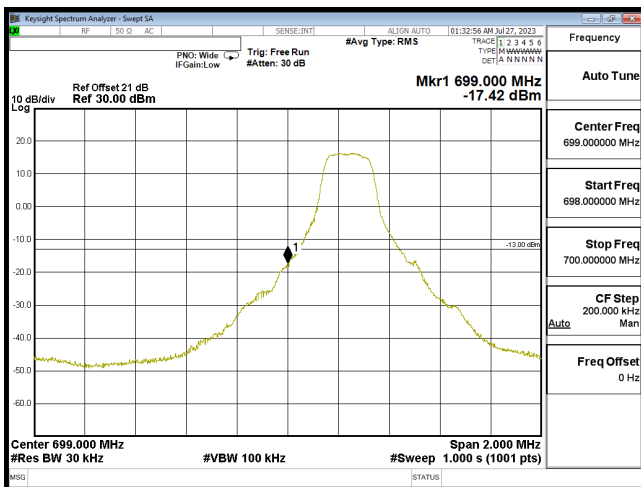

Bandedge B12 3M CH23025 QPSK(1,0)

Bandedge B12 3M CH23165 QPSK(1,14)

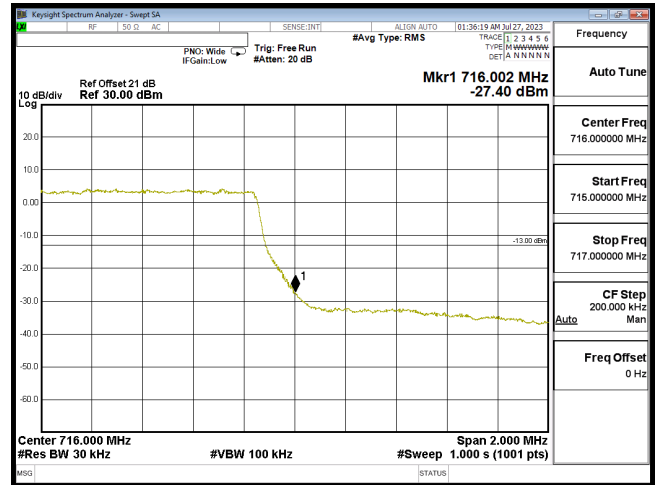
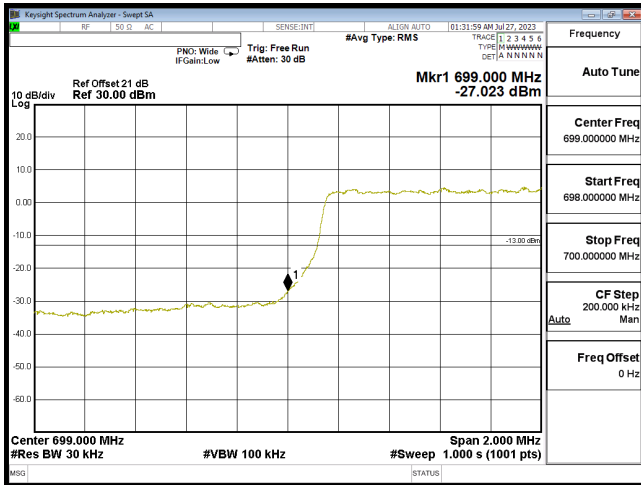

Bandedge B12 3M CH23025 QPSK(15,0)

Bandedge B12 3M CH23165 QPSK(15,0)

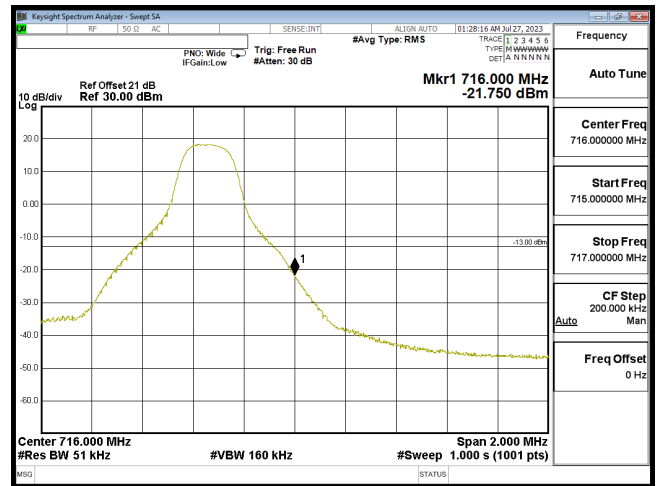
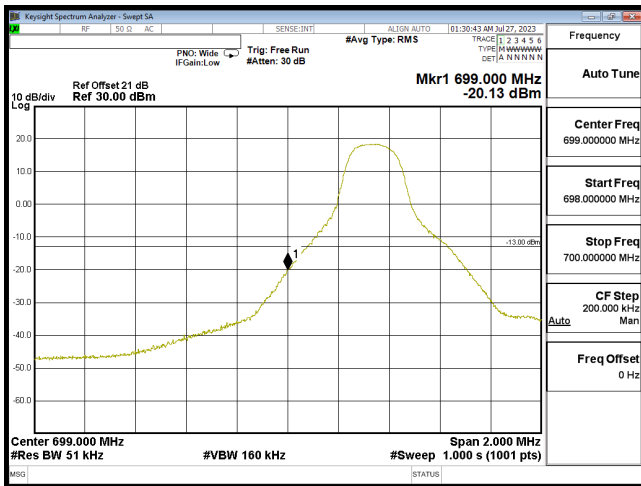

Bandedge B12 5M CH23035 QPSK(1,0)

Bandedge B12 5M CH23165 QPSK(1,24)

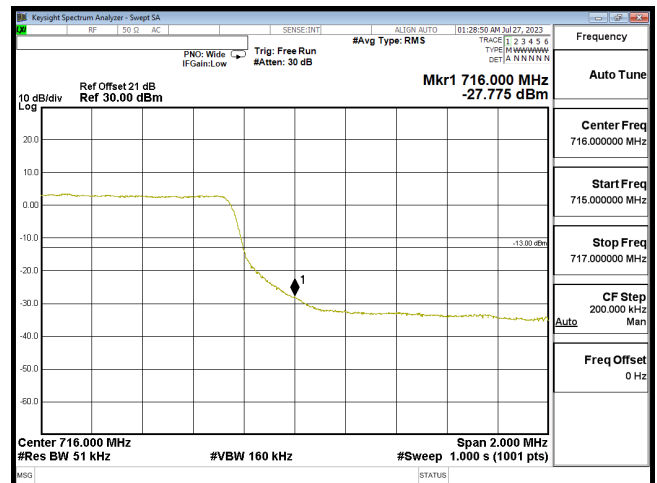
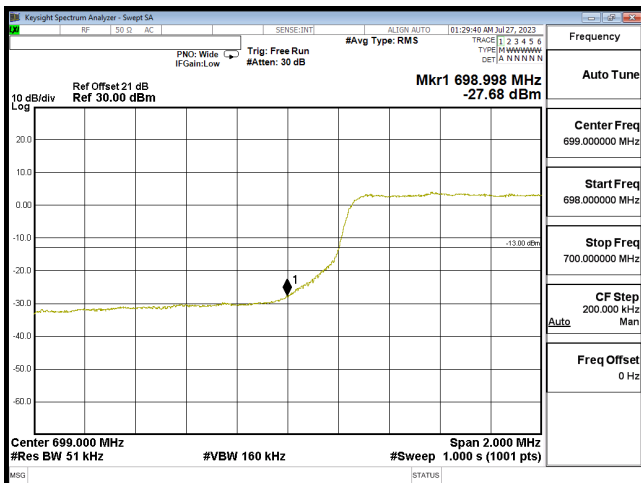

Bandedge B12 5M CH23035 QPSK(25,0)

Bandedge B12 5M CH23165 QPSK(25,0)



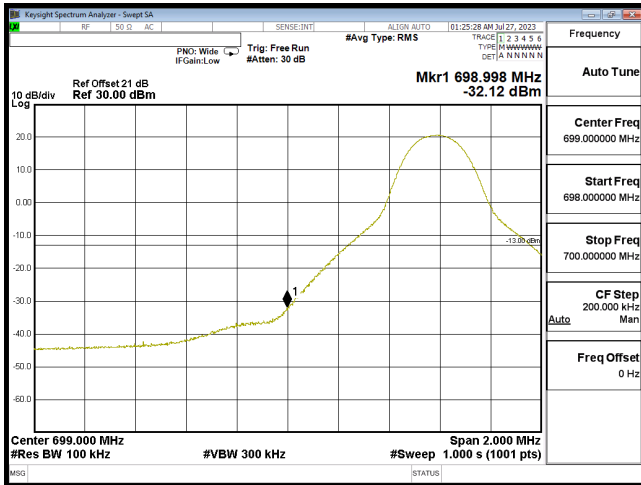

Bandedge B12 10M CH23060 QPSK(1,0)

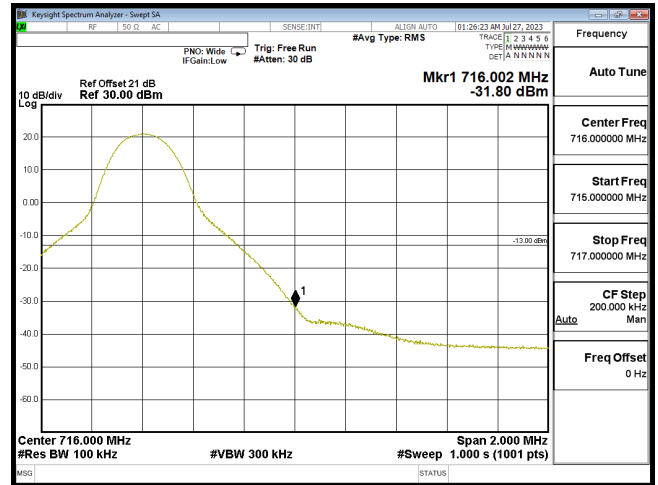

Bandedge B12 10M CH23130 QPSK(1,49)

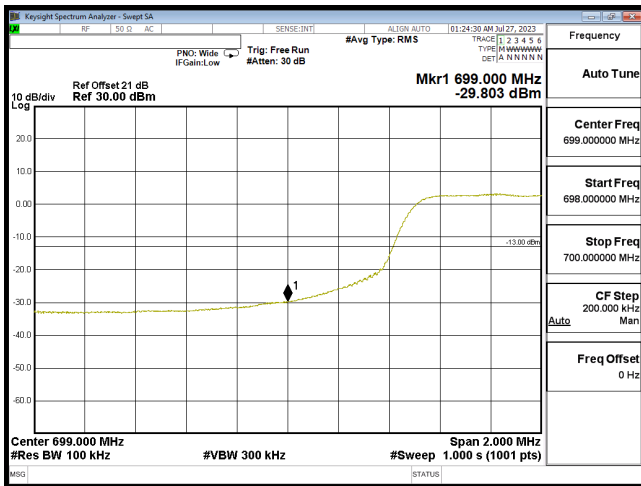

Bandedge B12 10M CH23060 QPSK(50,0)

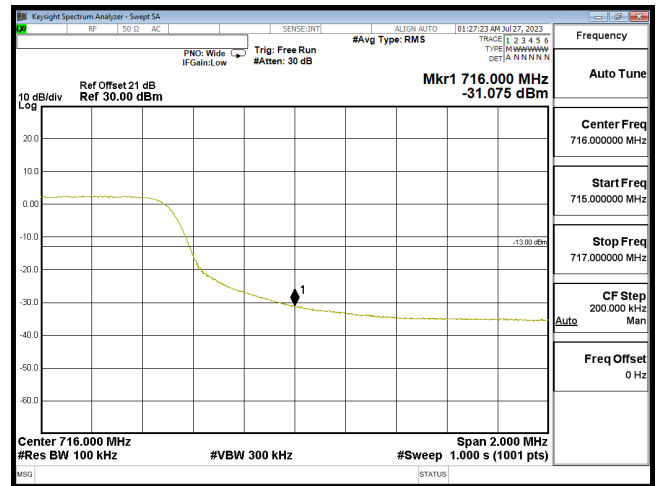

Bandedge B12 10M CH23130 QPSK(50,0)

LTE Band 13

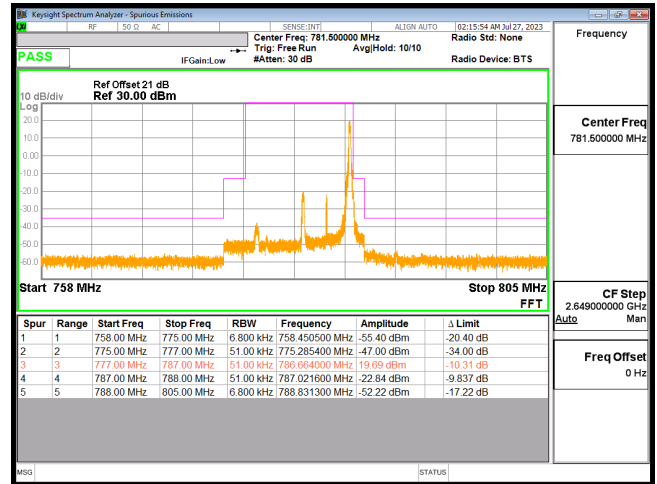
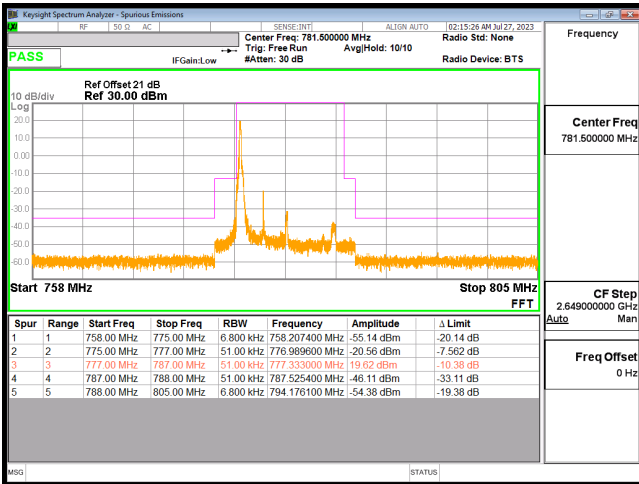

Bandedge B13 5M CH23205 QPSK(1,0)

Bandedge B13 5M CH23255 QPSK(1,24)

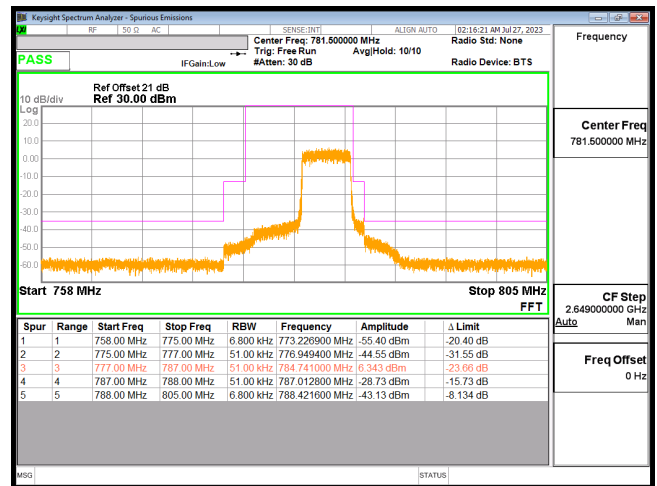
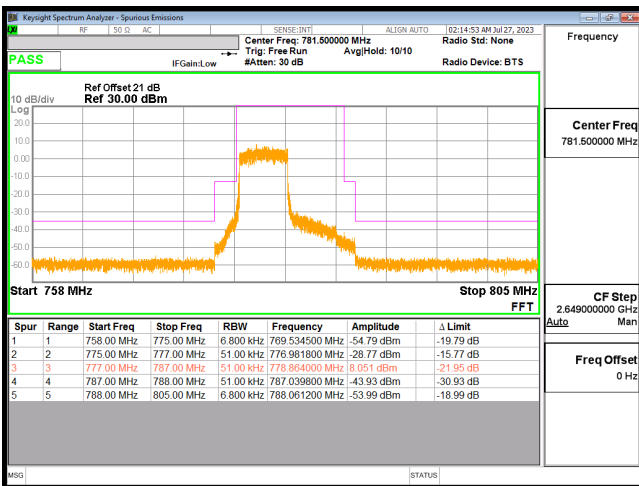

Bandedge B13 5M CH23205 QPSK(25,0)

Bandedge B13 5M CH23255 QPSK(25,0)

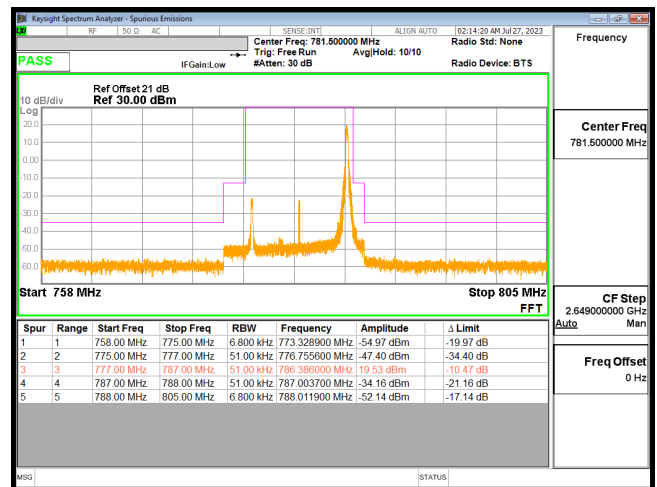
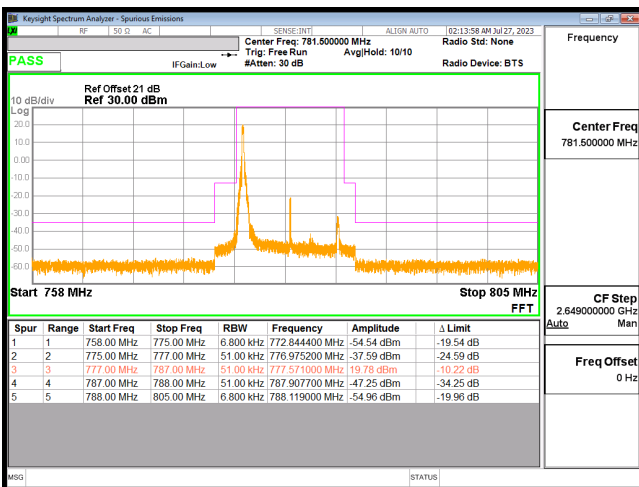

Bandedge B13 10M CH23230 QPSK(1,0)

Bandedge B13 10M CH23230 QPSK(1,49)

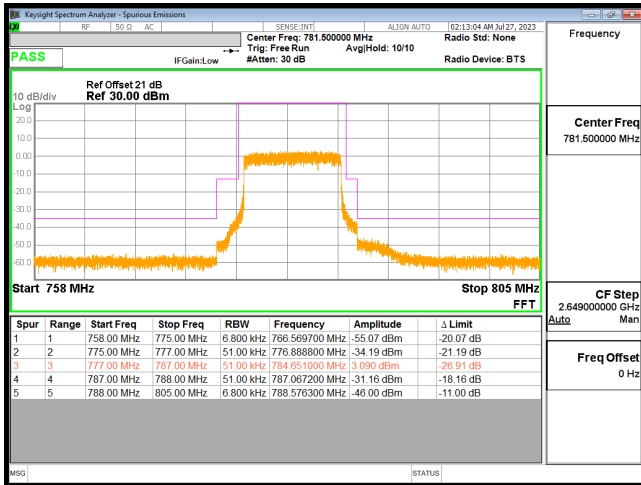

Bandedge B13 10M CH23230 QPSK(50,0)

LTE Band 25

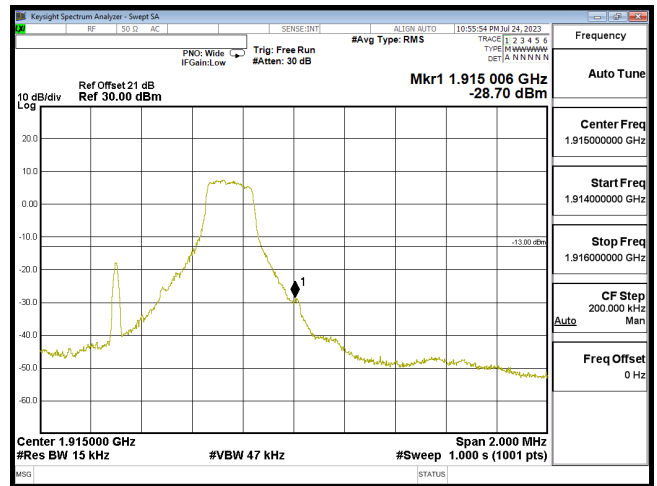
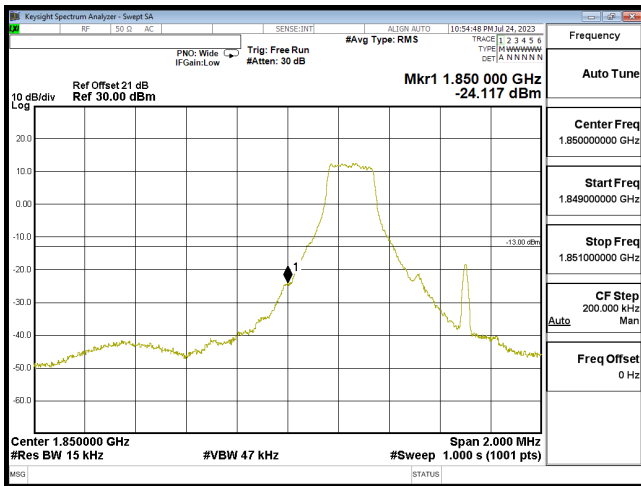

Bandedge B25 1.4M CH26047 QPSK(1,0)

Bandedge B25 1.4M CH26683 QPSK(1,5)

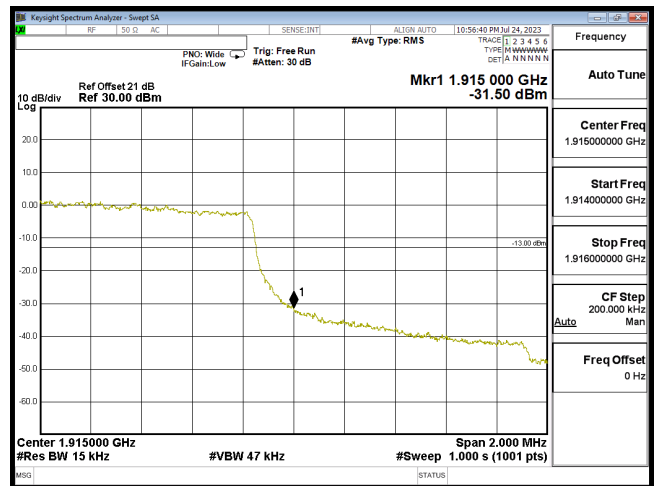
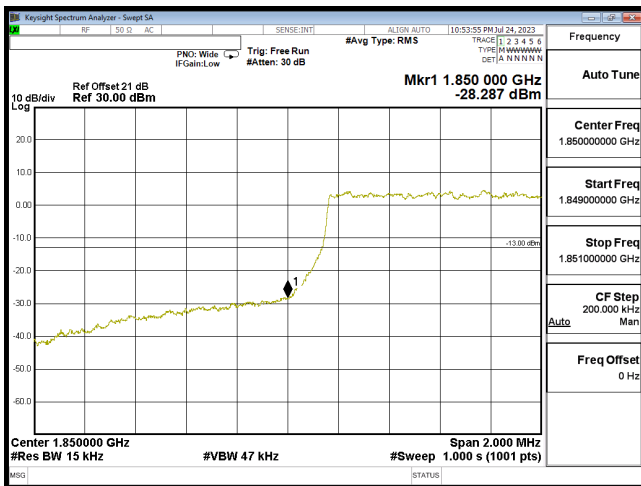

Bandedge B25 1.4M CH26047 QPSK(6,0)

Bandedge B25 1.4M CH26683 QPSK(6,0)

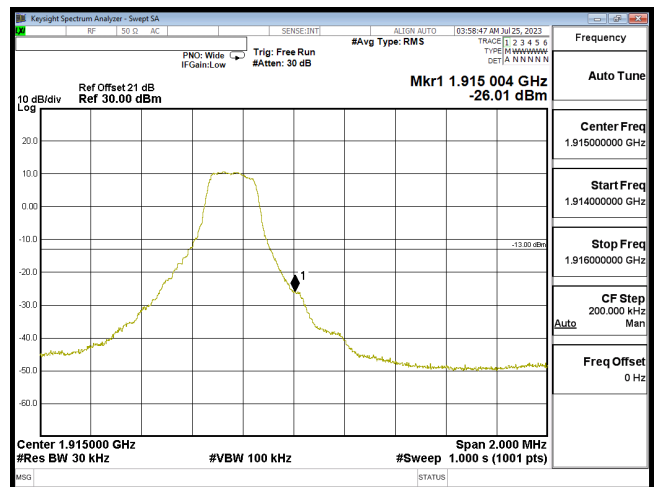
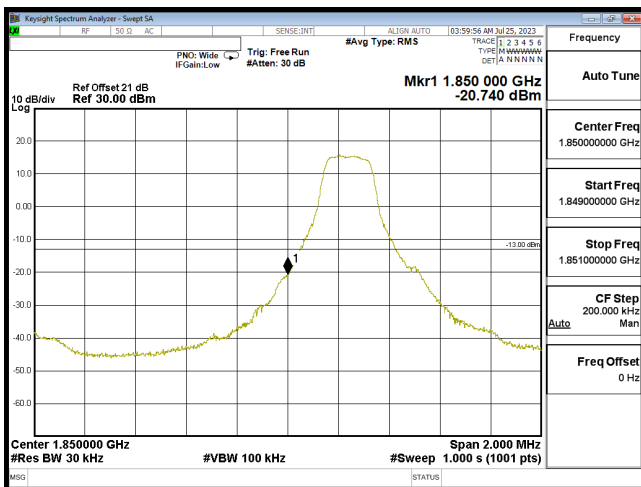

Bandedge B25 3M CH26055 QPSK(1,0)

Bandedge B25 3M CH26675 QPSK(1,14)

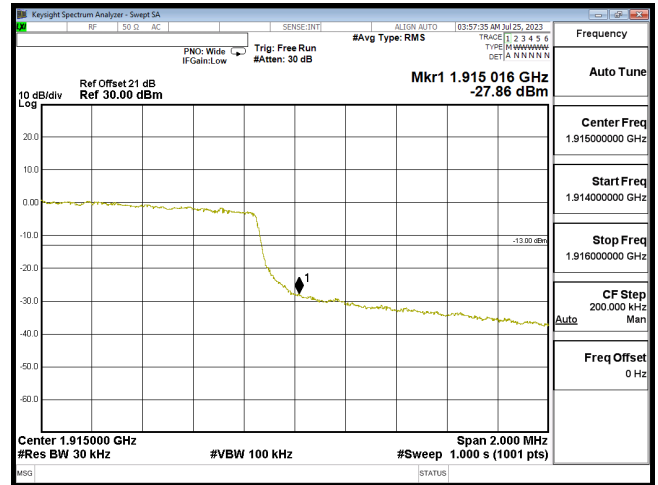
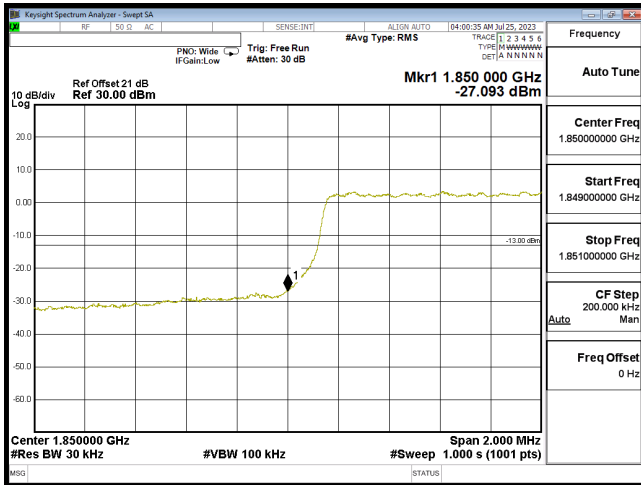

Bandedge B25 3M CH26055 QPSK(15,0)

Bandedge B25 3M CH26675 QPSK(15,0)

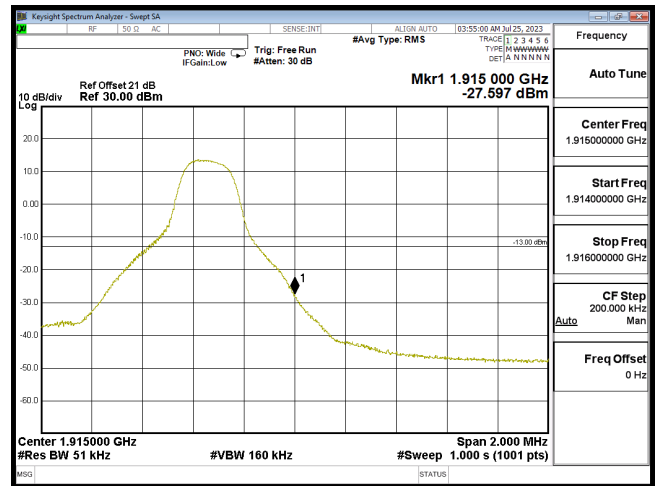
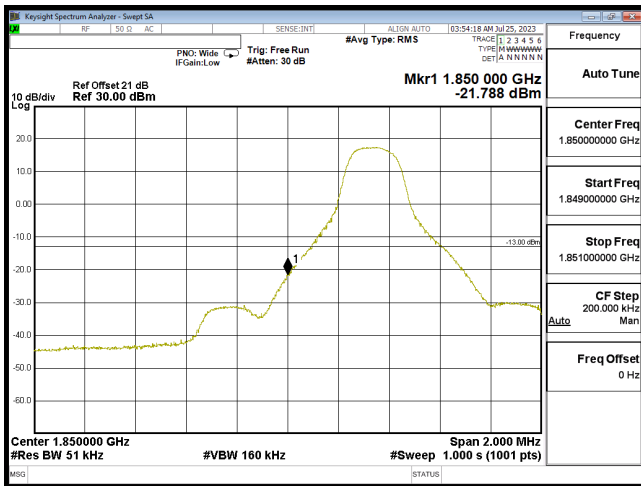

Bandedge B25 5M CH26065 QPSK(1,0)

Bandedge B25 5M CH26665 QPSK(1,24)

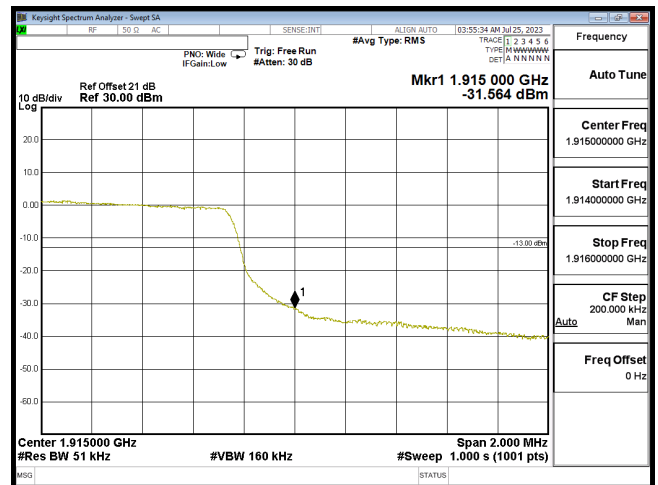
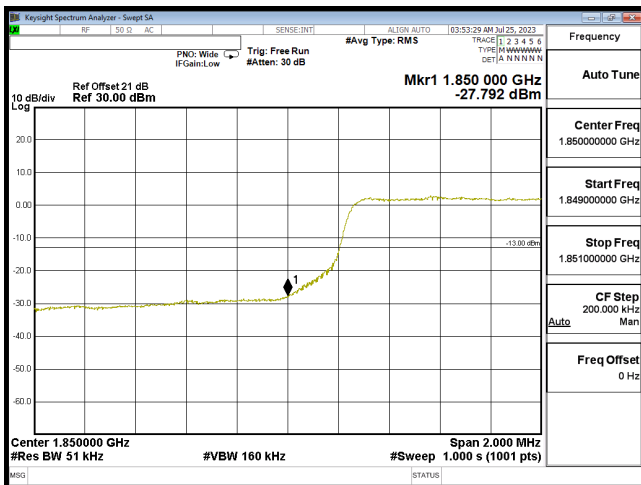

Bandedge B25 5M CH26065 QPSK(25,0)

Bandedge B25 5M CH26665 QPSK(25,0)

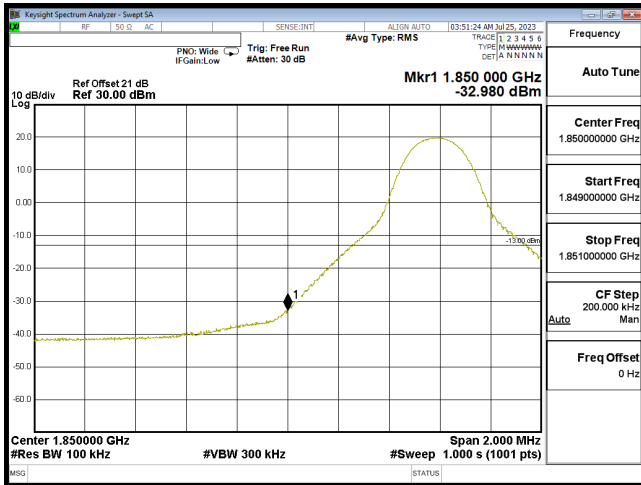

Bandedge B25 10M CH26090 QPSK(1,0)

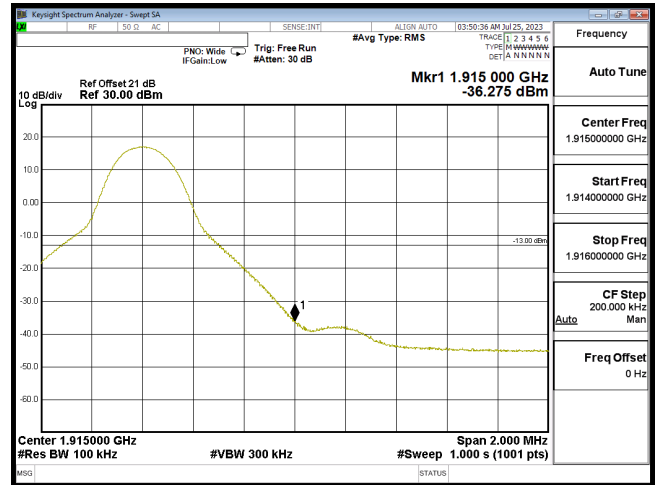

Bandedge B25 10M CH26640 QPSK(1,49)

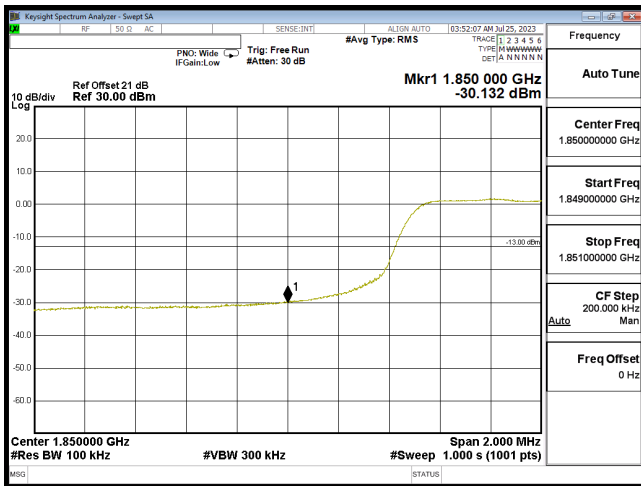

Bandedge B25 10M CH26090 QPSK(50,0)

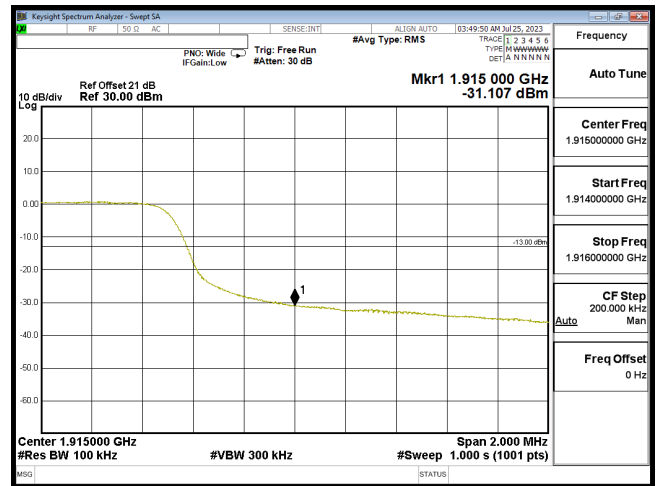

Bandedge B25 10M CH26640 QPSK(50,0)

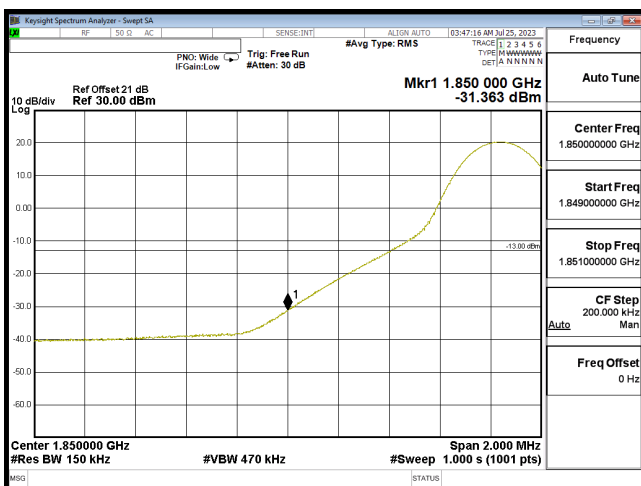

Bandedge B25 15M CH26115 QPSK(1,0)

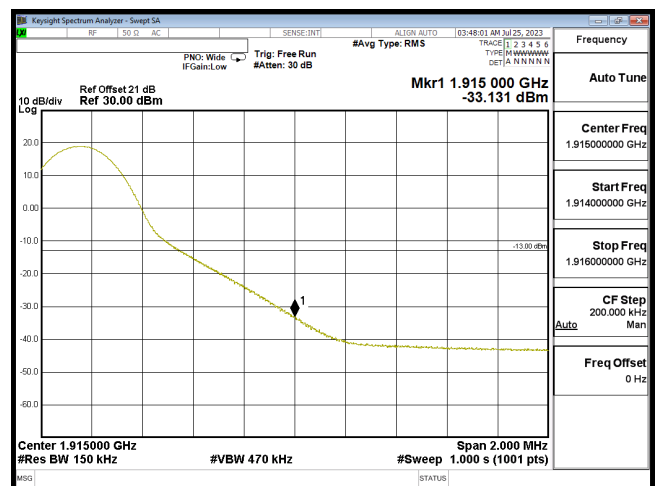

Bandedge B25 15M CH26615 QPSK(1,74)

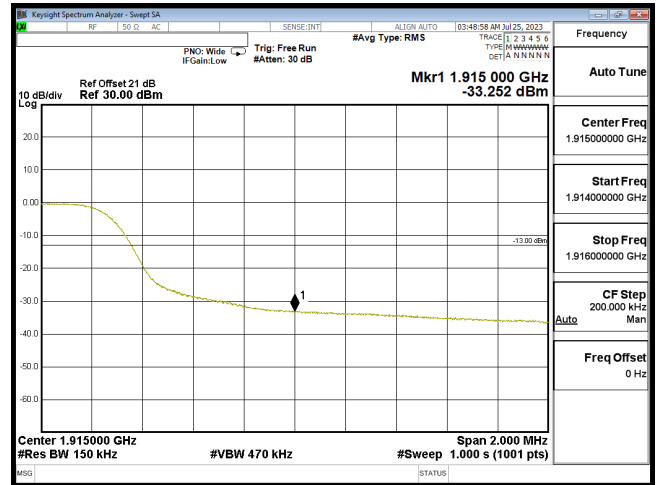
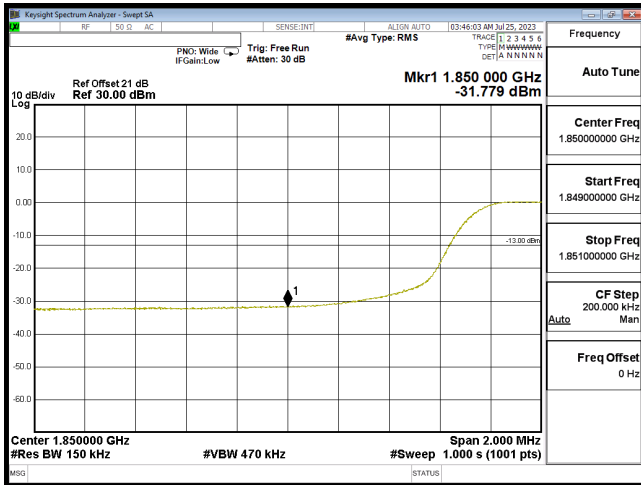

Bandedge B25 15M CH26115 QPSK(75,0)

Bandedge B25 15M CH26615 QPSK(75,0)

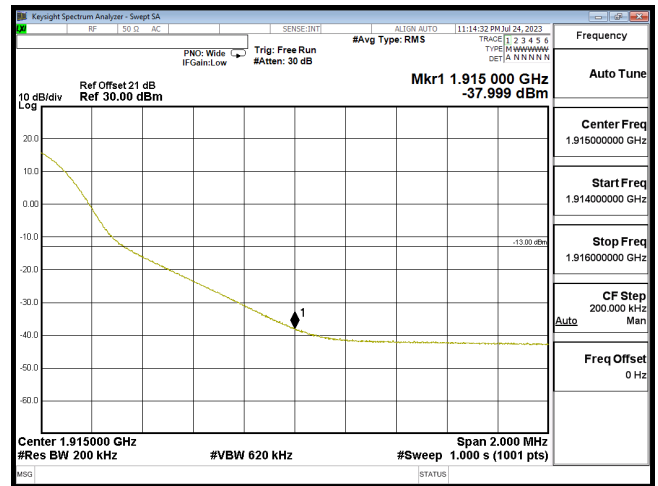
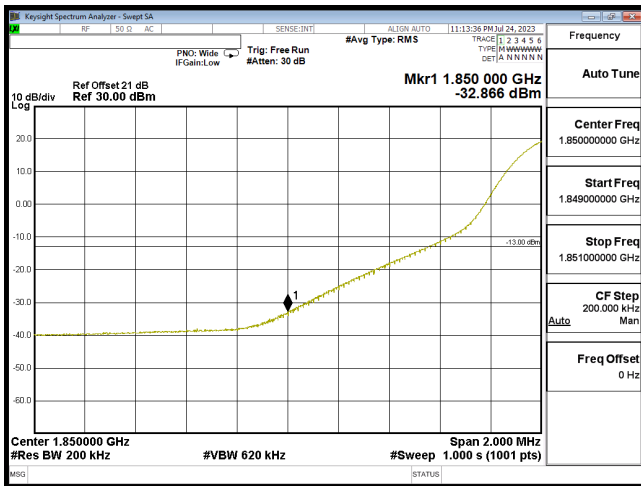

Bandedge B25 20M CH26140 QPSK(1,0)

Bandedge B25 20M CH26590 QPSK(1,99)

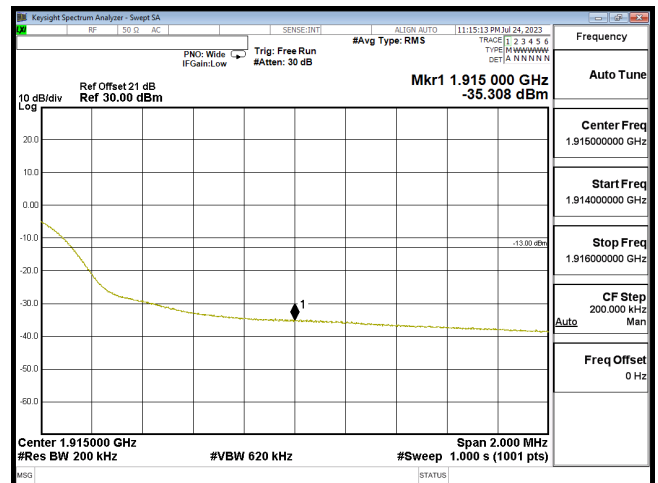
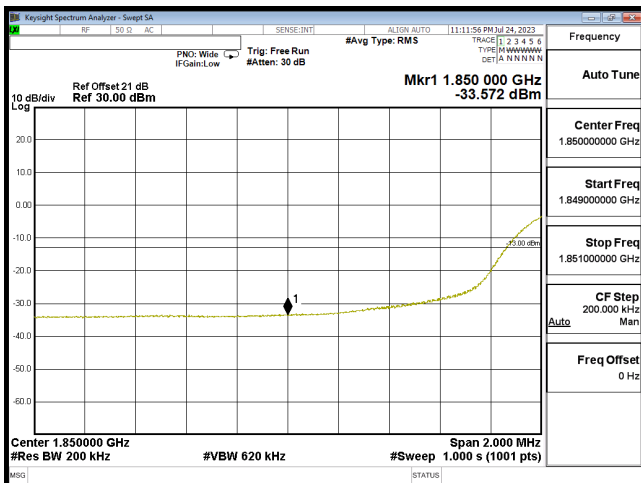

Bandedge B25 20M CH26140 QPSK(100,0)

Bandedge B25 20M CH26590 QPSK(100,0)

### LTE Band 26

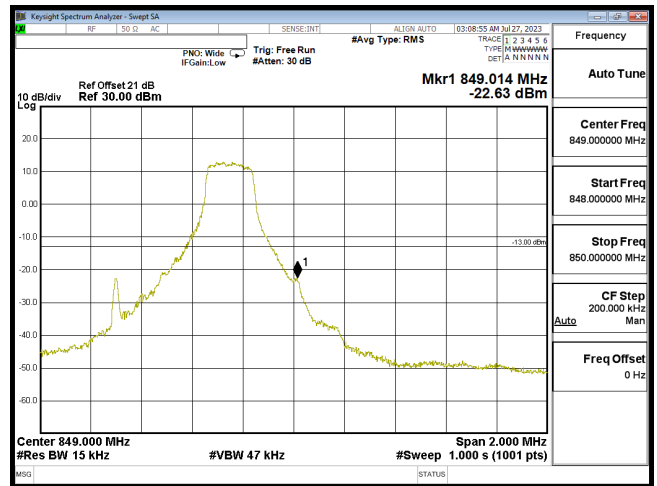
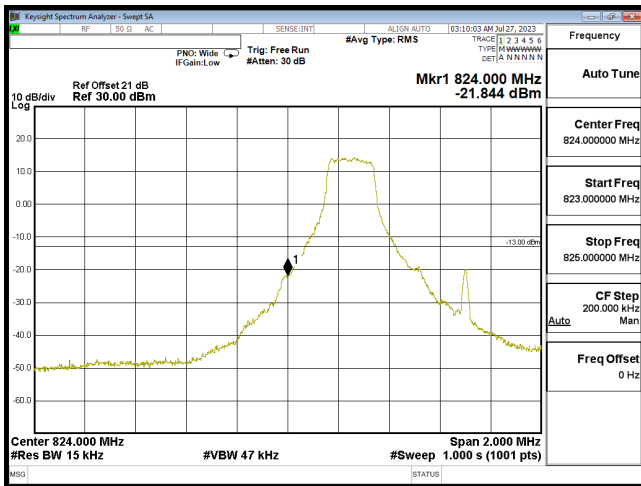

Bandedge B26 1.4M CH26797 QPSK(1,0)

Bandedge B26 1.4M CH27033 QPSK(1,5)

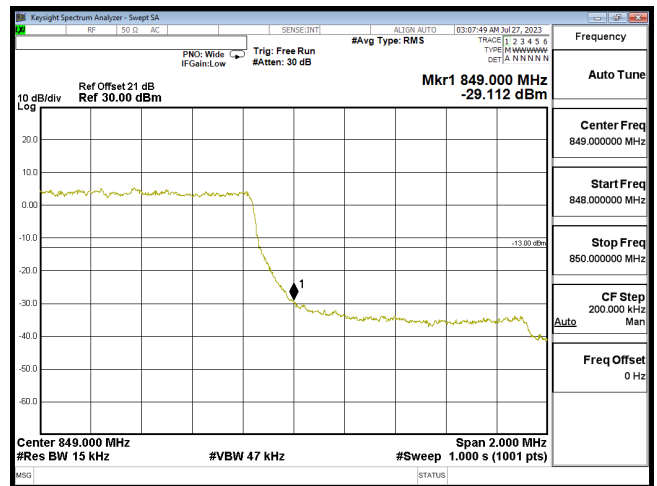
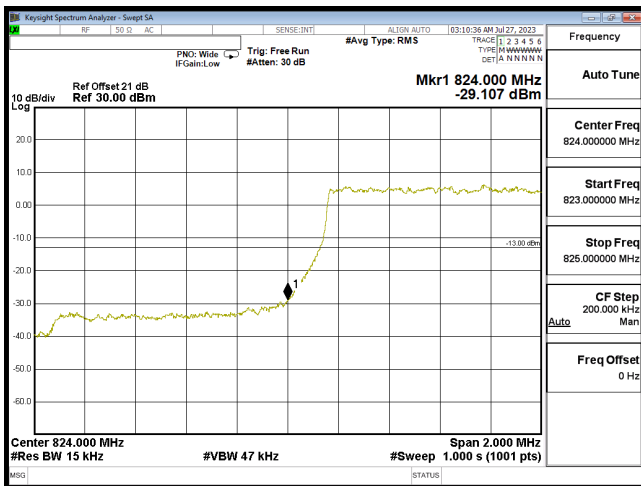

Bandedge B26 1.4M CH26797 QPSK(6,0)

Bandedge B26 1.4M CH27033 QPSK(6,0)

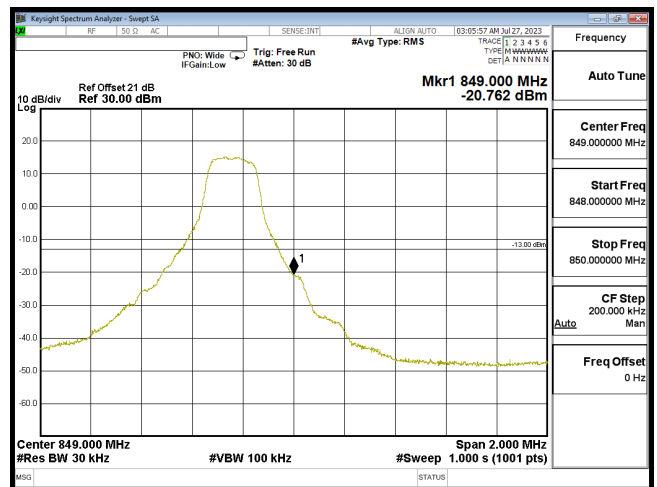
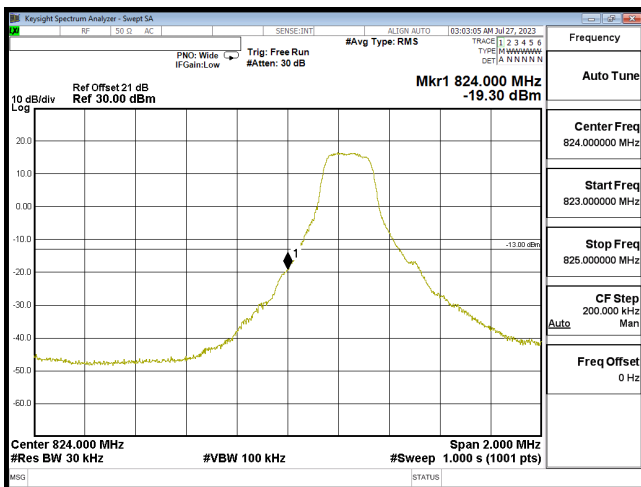

Bandedge B26 3M CH26805 QPSK(1,0)

Bandedge B26 3M CH27025 QPSK(1,14)



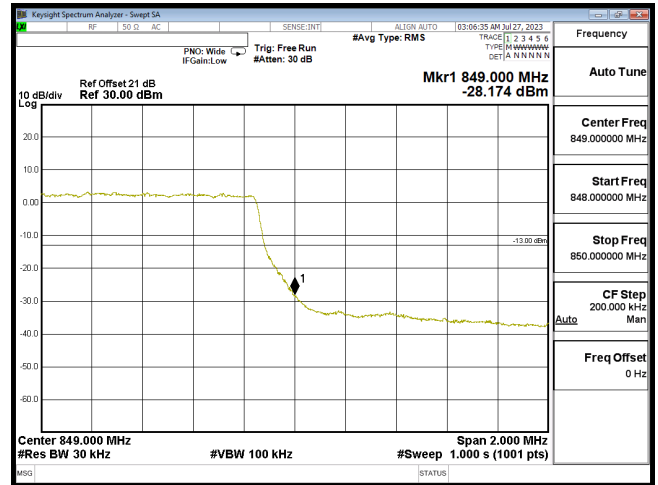
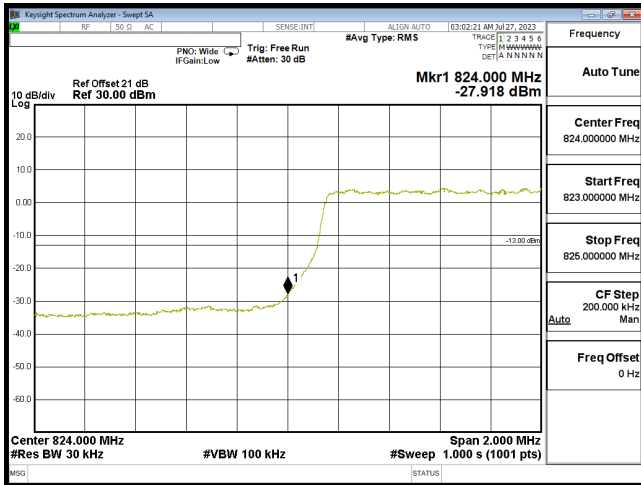

Bandedge B26 3M CH26805 QPSK(15,0)

Bandedge B26 3M CH27025 QPSK(15,0)

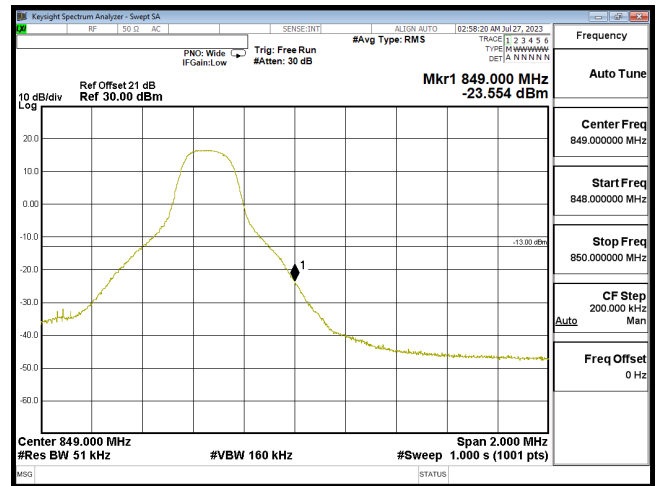
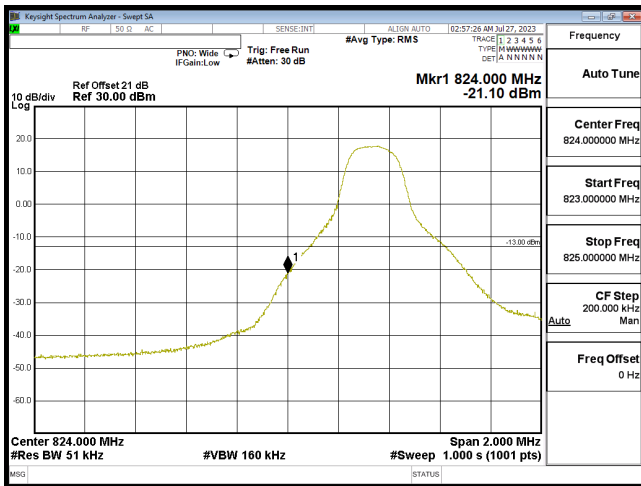

Bandedge B26 5M CH26815 QPSK(1,0)

Bandedge B26 5M CH27015 QPSK(1,24)

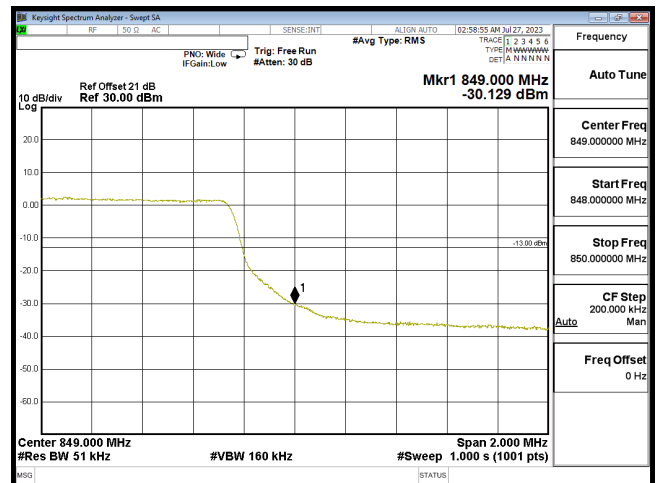
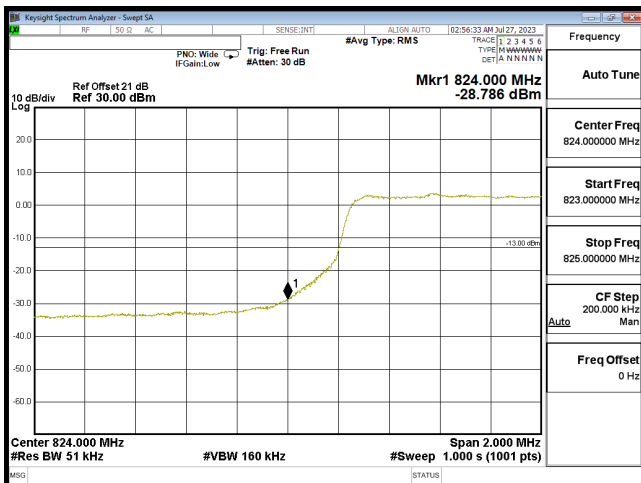

Bandedge B26 5M CH26815 QPSK(25,0)

Bandedge B26 5M CH27015 QPSK(25,0)

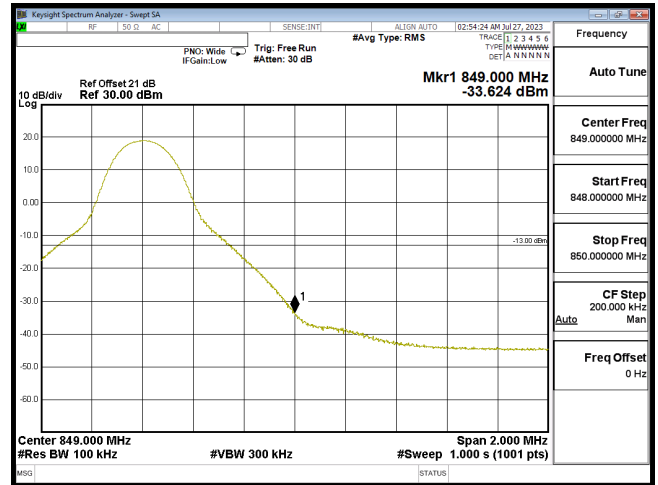
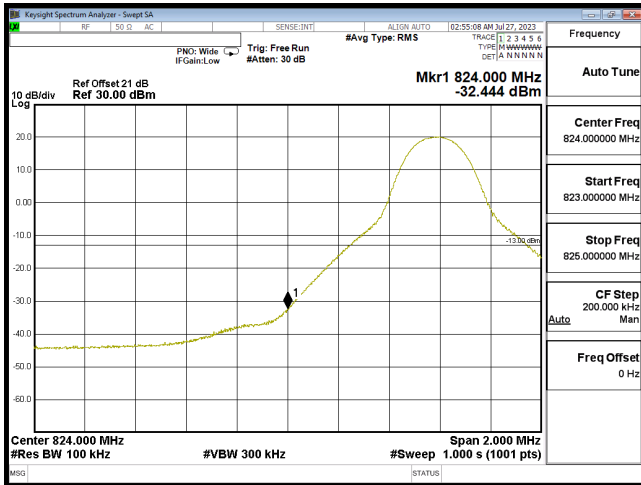

Bandedge B26 10M CH26840 QPSK(1,0)

Bandedge B26 10M CH26990 QPSK(1,49)

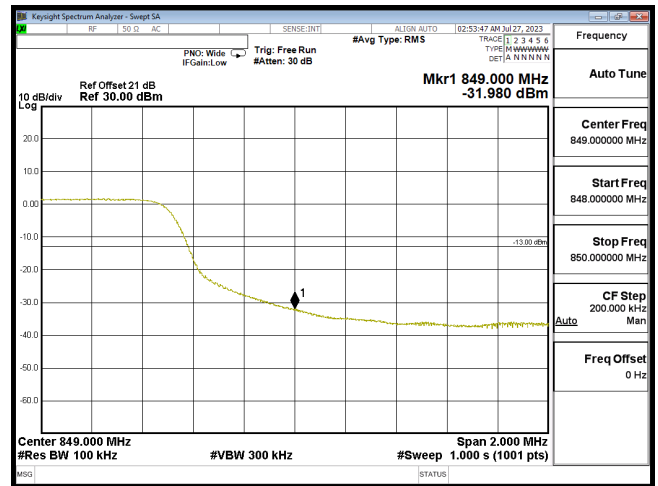
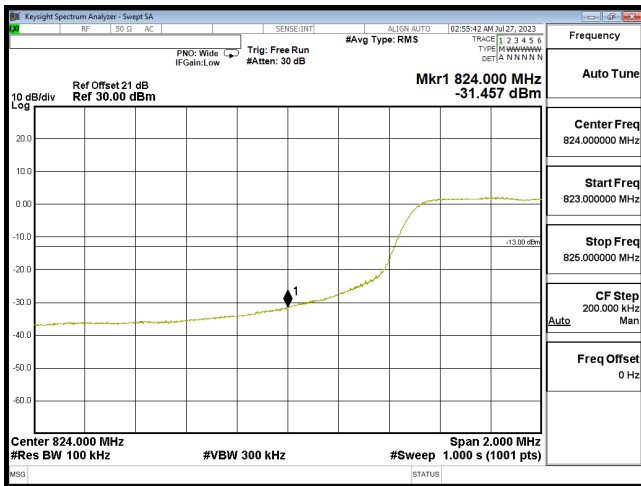

Bandedge B26 10M CH26840 QPSK(50,0)

Bandedge B26 10M CH26990 QPSK(50,0)

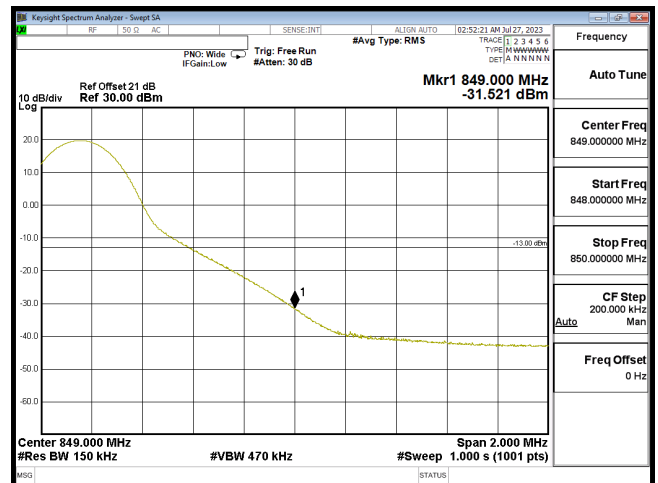
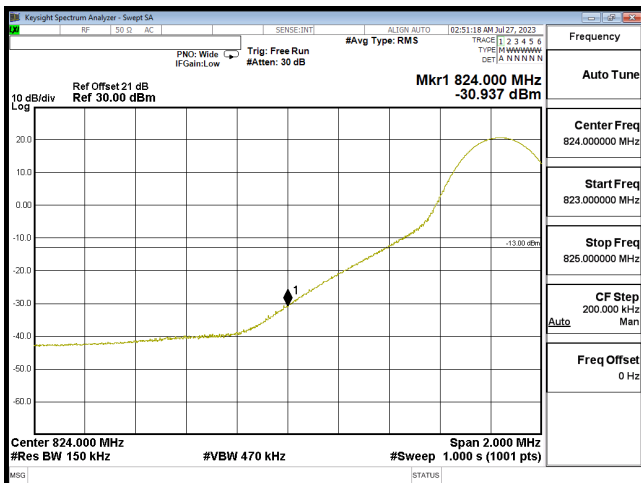

Bandedge B26 15M CH26865 QPSK(1,0)

Bandedge B26 15M CH26965 QPSK(1,74)

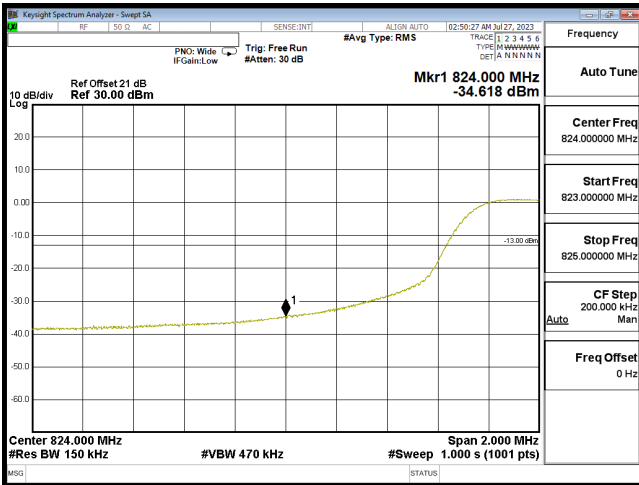

Bandedge B26 15M CH26865 QPSK(75,0)

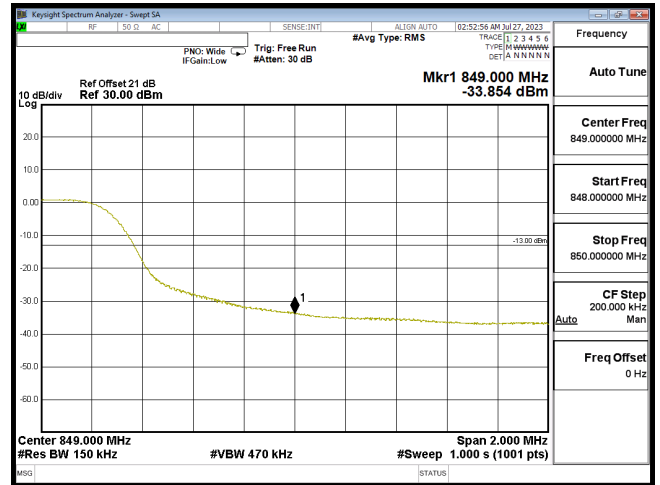

Bandedge B26 15M CH26965 QPSK(75,0)

### LTE Band 41

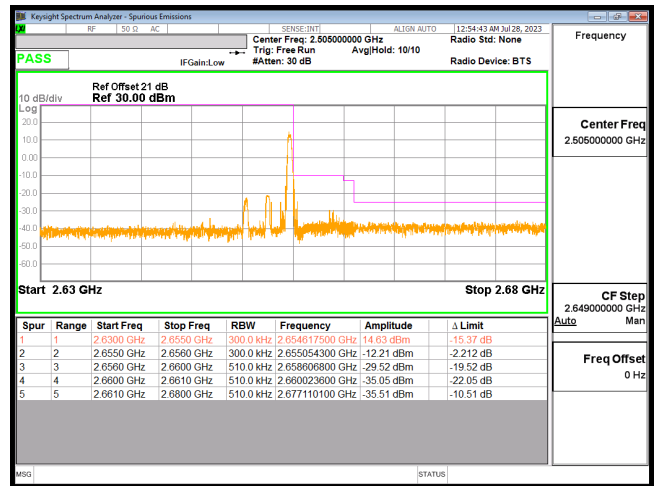
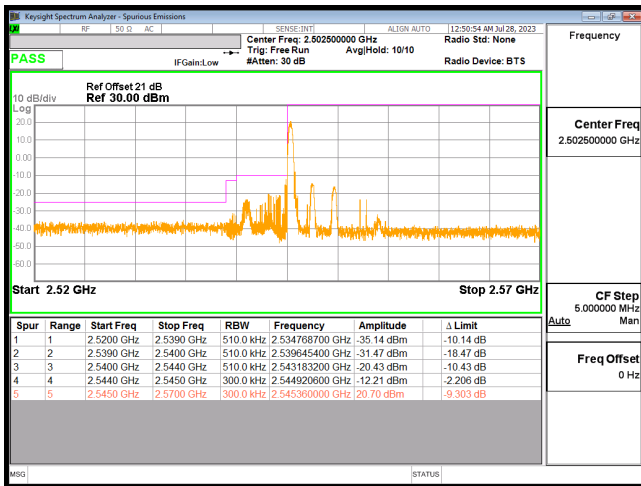

### Bandedge B41 5M CH40165 QPSK(1,0)

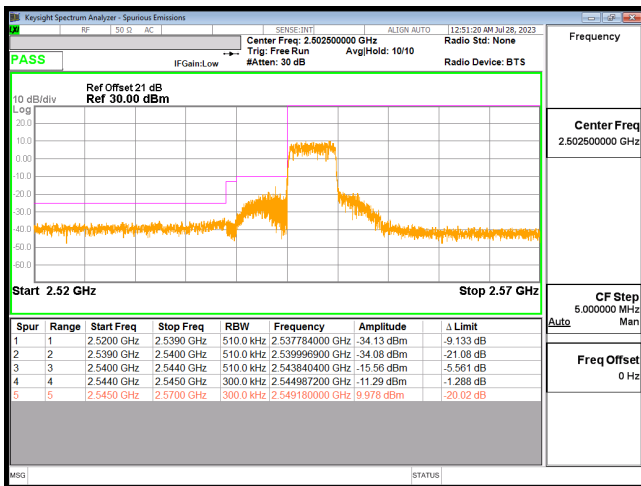

### Bandedge B41 5M CH41215 QPSK(1,24)



### Bandedge B41 5M CH40165 QPSK(25,0)

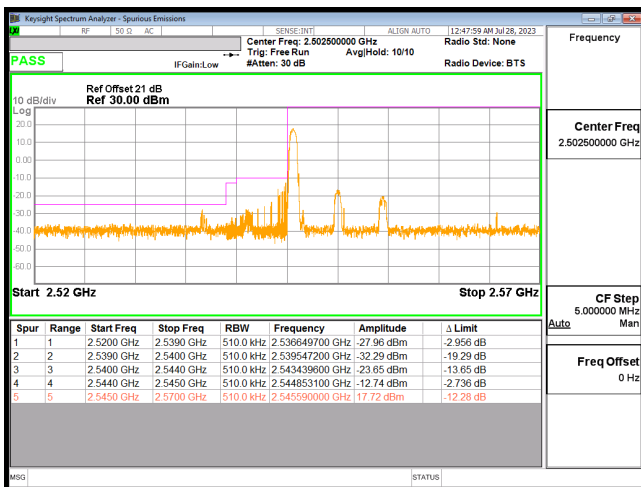

### Bandedge B41 5M CH41215 QPSK(25,0)

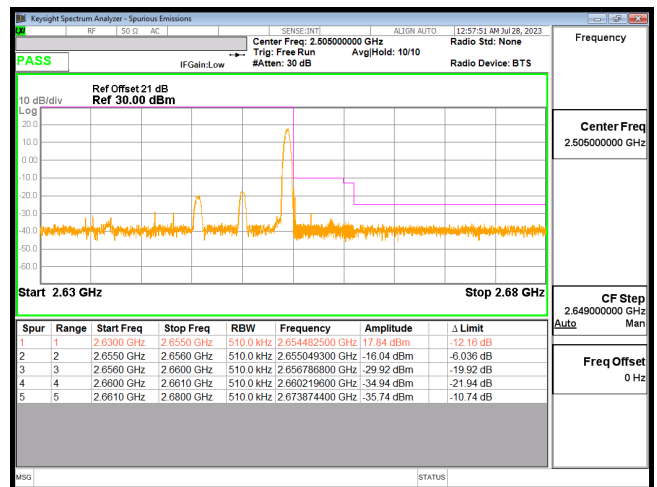

### Bandedge B41 10M CH40190 QPSK(1,0)



### Bandedge B41 10M CH41190 QPSK(1,49)



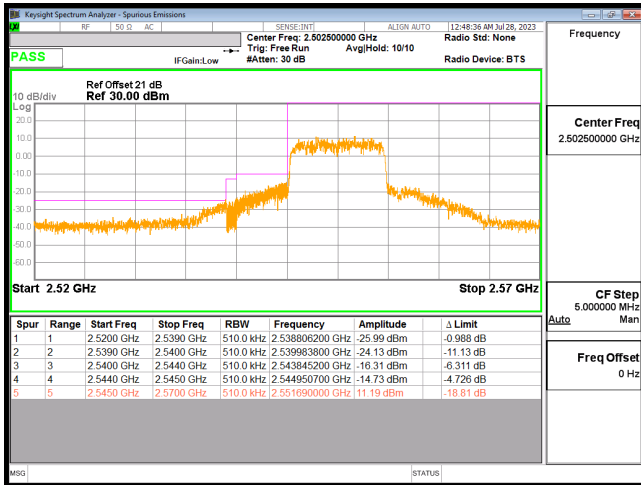

Bandedge B41 10M CH40190 QPSK(50,0)



Bandedge B41 10M CH41190 QPSK(50,0)

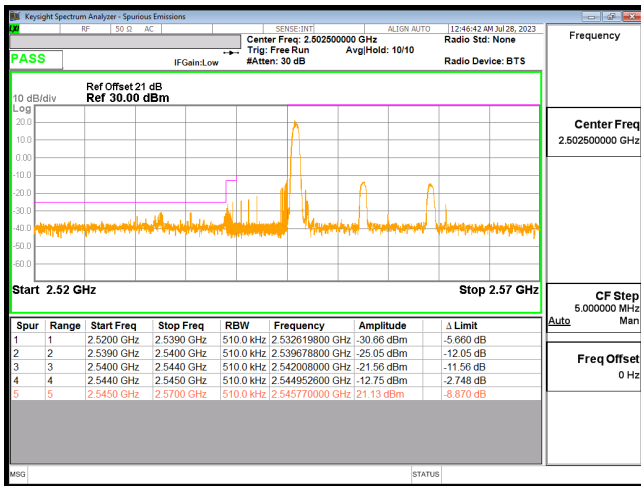

Bandedge B41 15M CH40215 QPSK(1,0)



Bandedge B41 15M CH41165 QPSK(1,74)

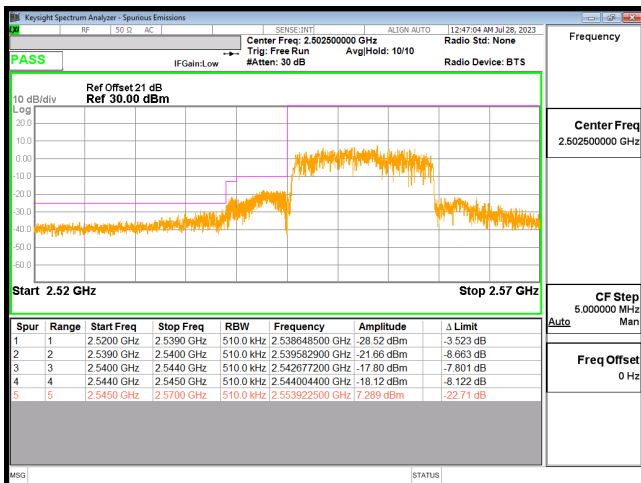

Bandedge B41 15M CH40215 QPSK(75,0)



Bandedge B41 15M CH41165 QPSK(75,0)

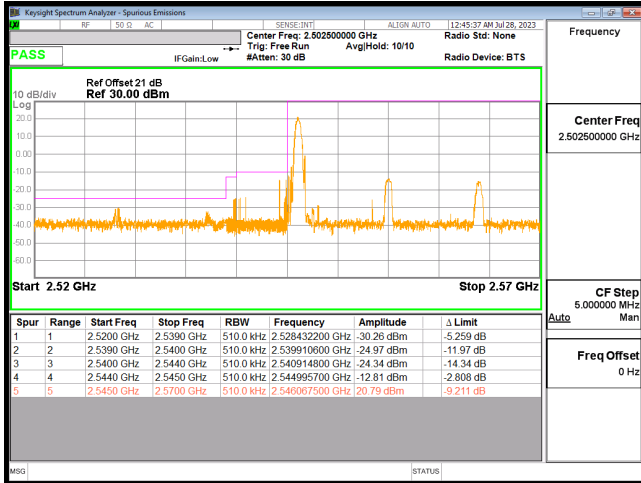

Bandedge B41 20M CH40240 QPSK(1,0)

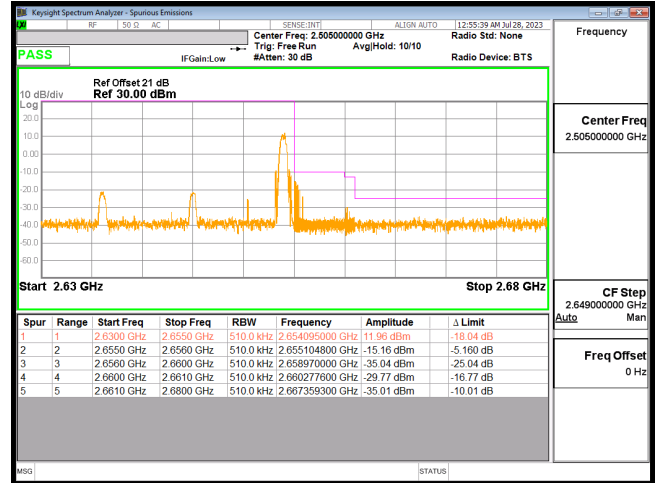

Bandedge B41 20M CH41140 QPSK(1,99)

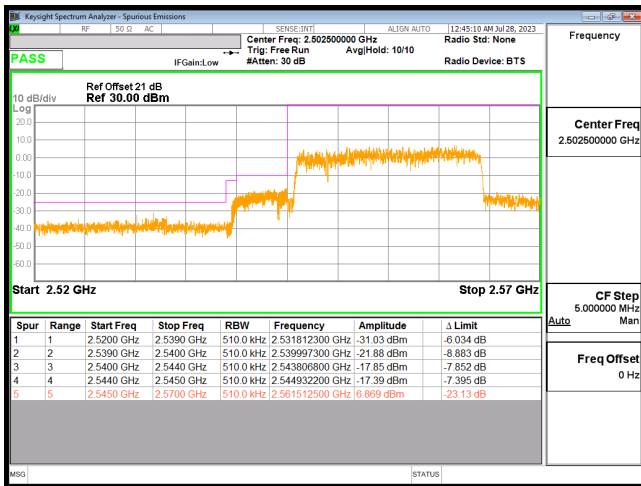

Bandedge B41 20M CH40240 QPSK(100,0)



Bandedge B41 20M CH41140 QPSK(100,0)

### LTE Band 66

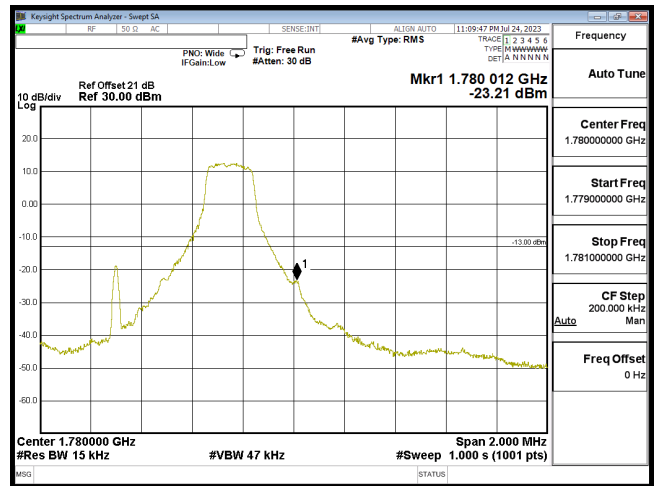
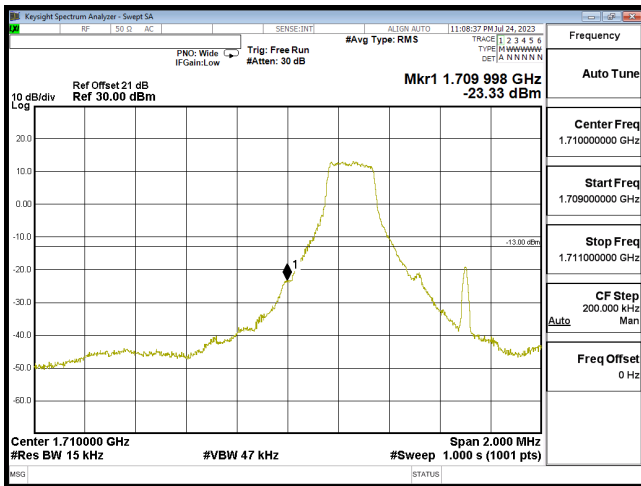

Bandedge B66 1.4M CH132665 QPSK(1,0)

Bandedge B66 1.4M CH132979 QPSK(1,5)

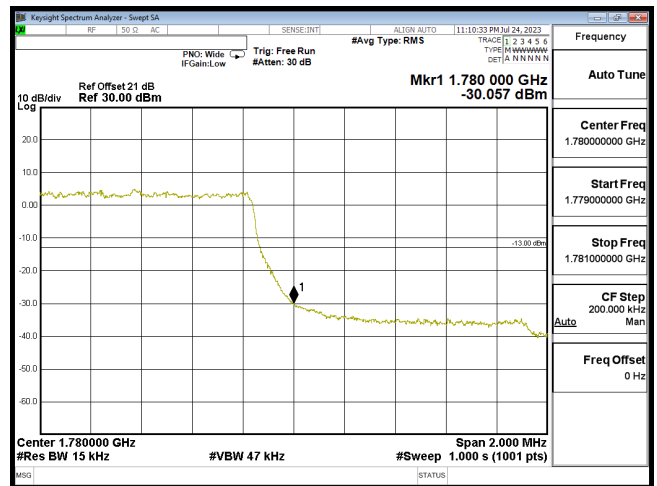
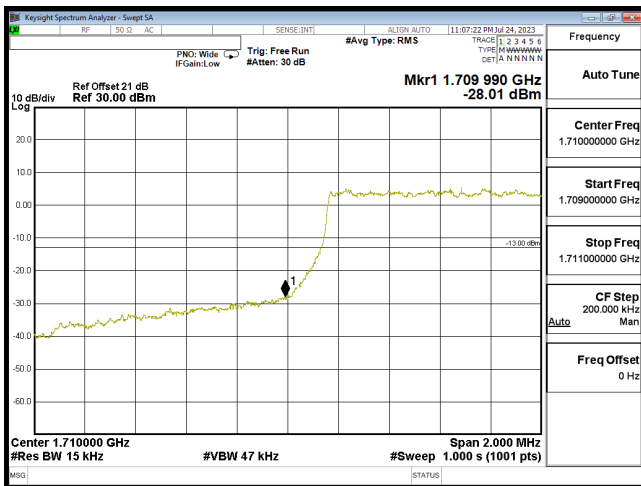

Bandedge B66 1.4M CH132665 QPSK(6,0)

Bandedge B66 1.4M CH132979 QPSK(6,0)

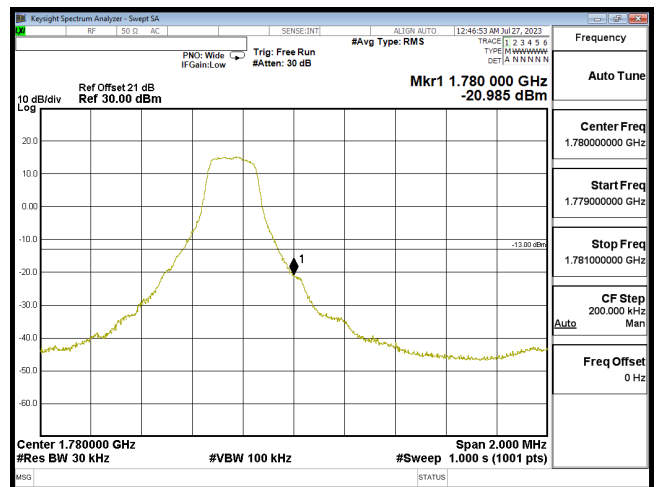
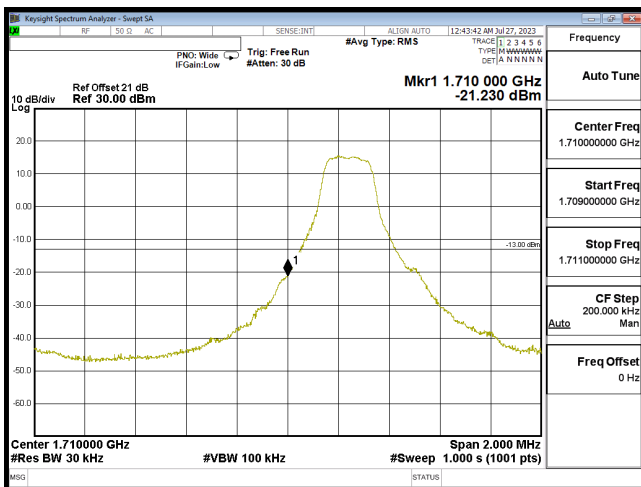

Bandedge B66 3M CH131987 QPSK(1,0)

Bandedge B66 3M CH132657 QPSK(1,14)

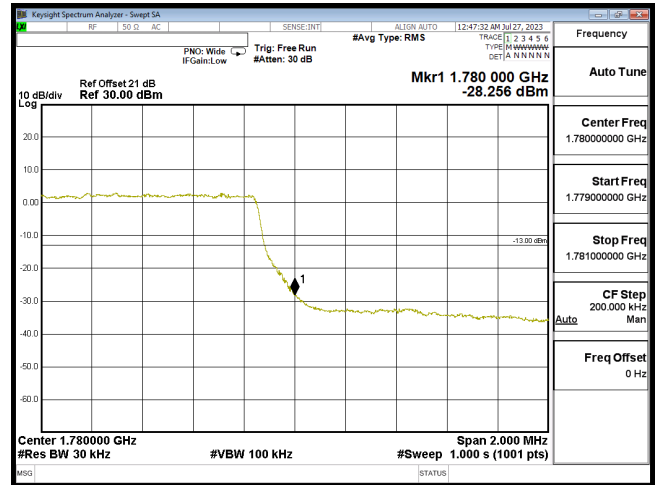
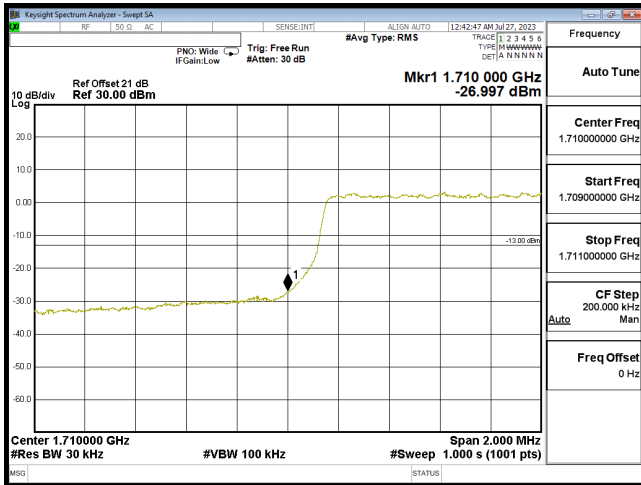

Bandedge B66 3M CH131987 QPSK(15,0)

Bandedge B66 3M CH132657 QPSK(15,0)

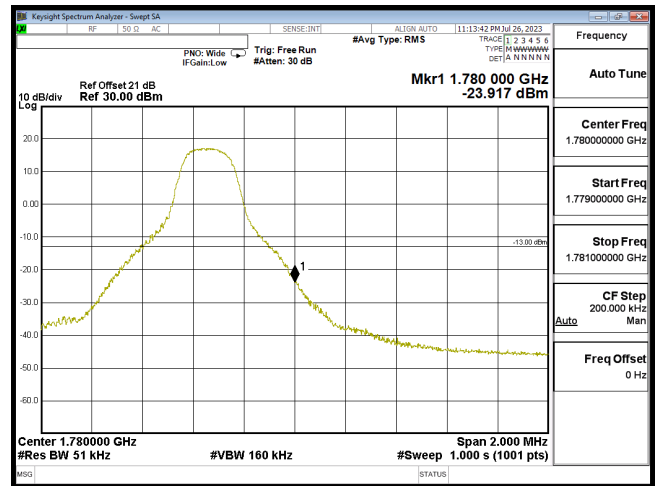
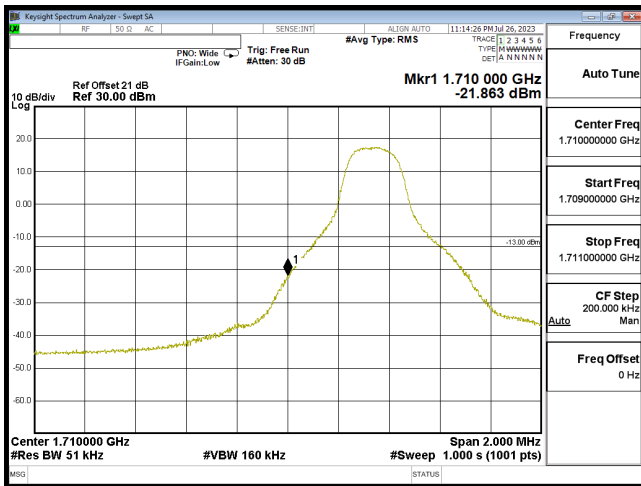

Bandedge B66 5M CH131997 QPSK(1,0)

Bandedge B66 5M CH132647 QPSK(1,24)

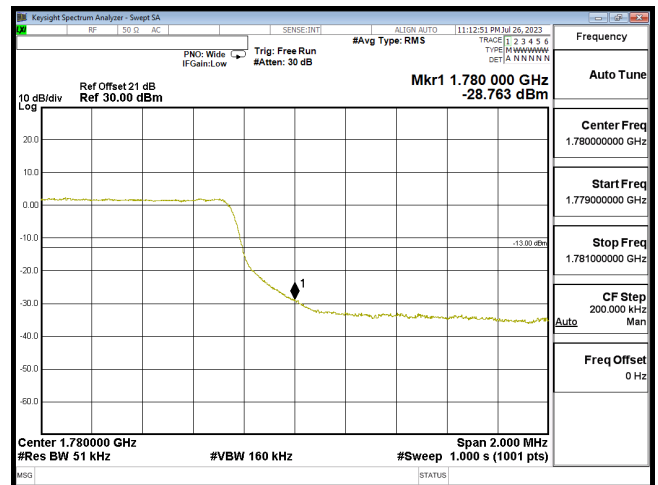
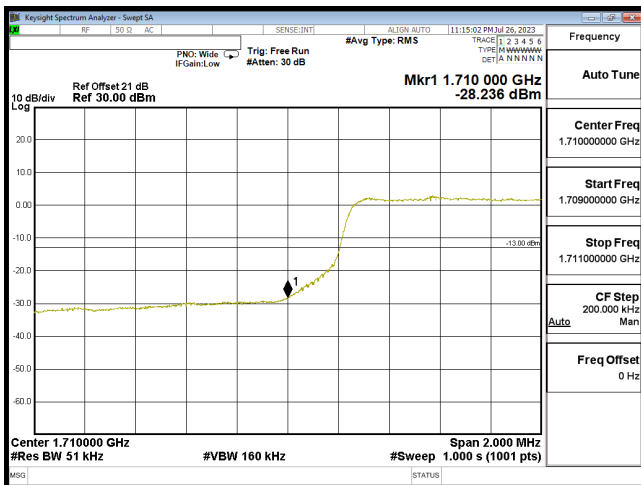

Bandedge B66 5M CH131997 QPSK(25,0)

Bandedge B66 5M CH132647 QPSK(25,0)



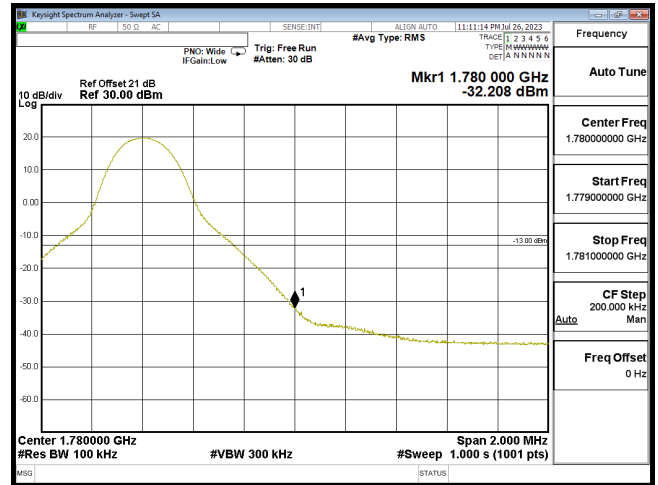
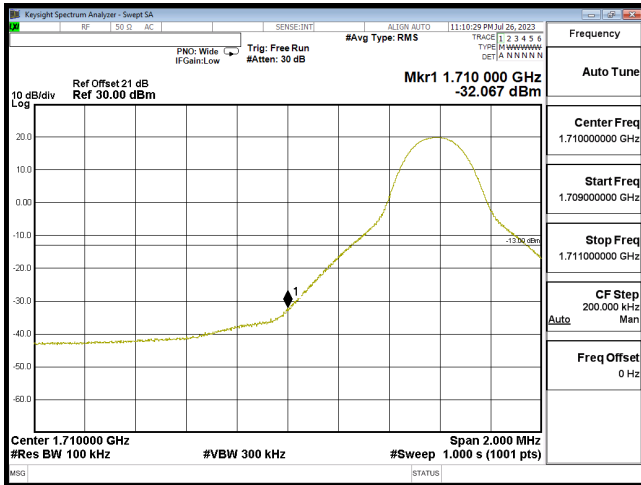

Bandedge B66 10M CH132022 QPSK(1,0)

Bandedge B66 10M CH132622 QPSK(1,49)

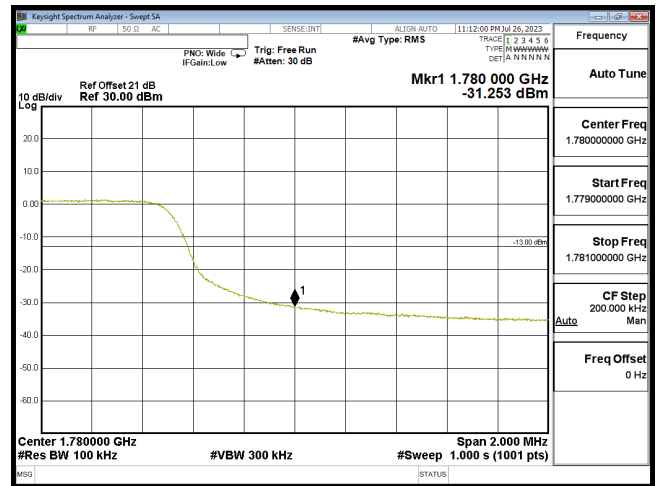
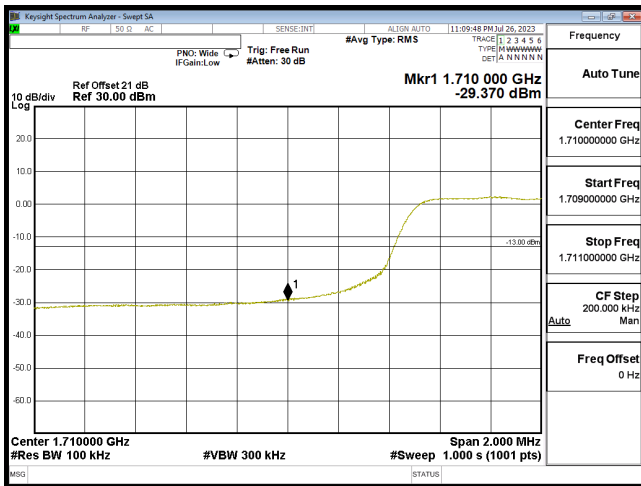

Bandedge B66 10M CH132022 QPSK(50,0)

Bandedge B66 10M CH132622 QPSK(50,0)

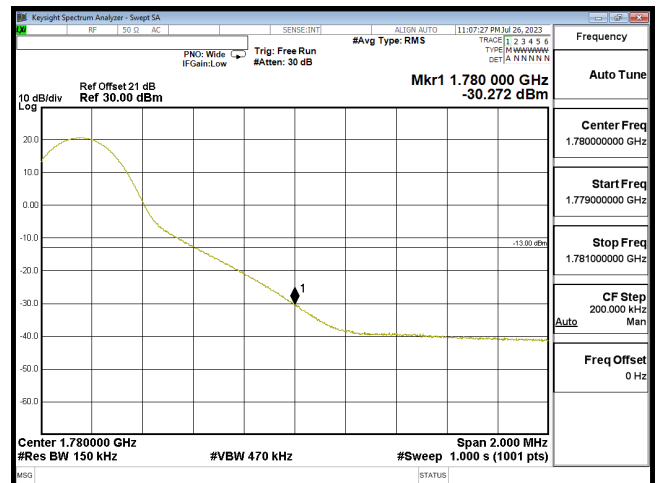
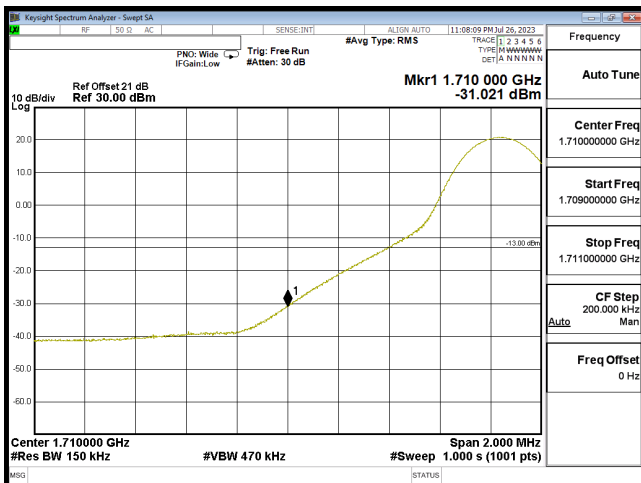

Bandedge B66 15M CH132047 QPSK(1,0)

Bandedge B66 15M CH132597 QPSK(1,74)

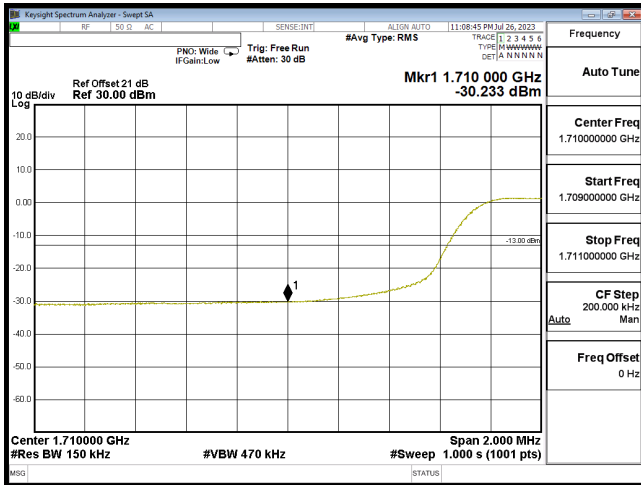

Bandedge B66 15M CH132047 QPSK(75,0)

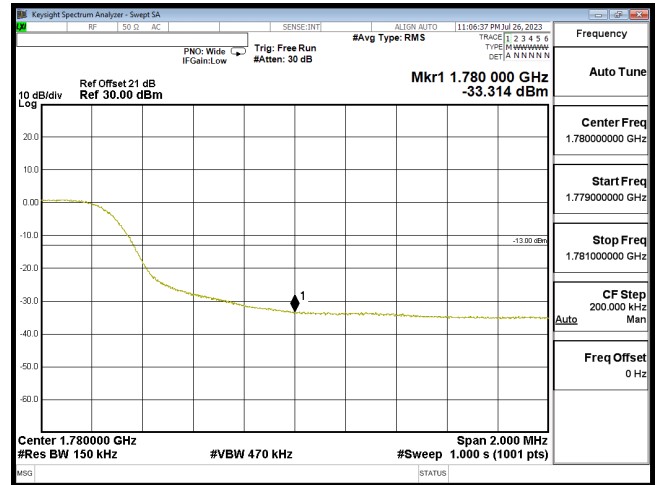

Bandedge B66 15M CH132597 QPSK(75,0)

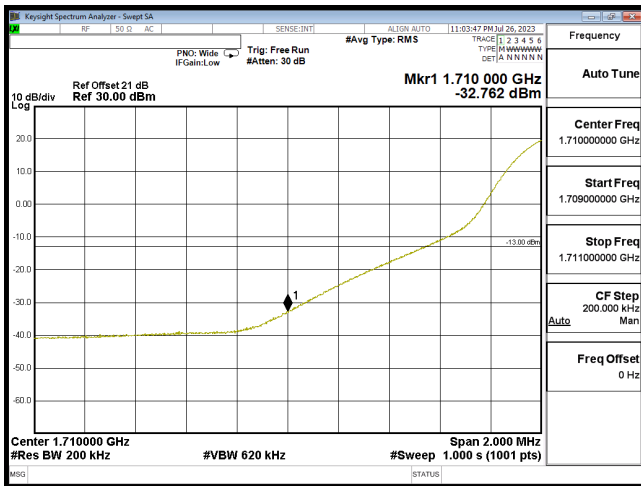

Bandedge B66 20M CH132072 QPSK(1,0)

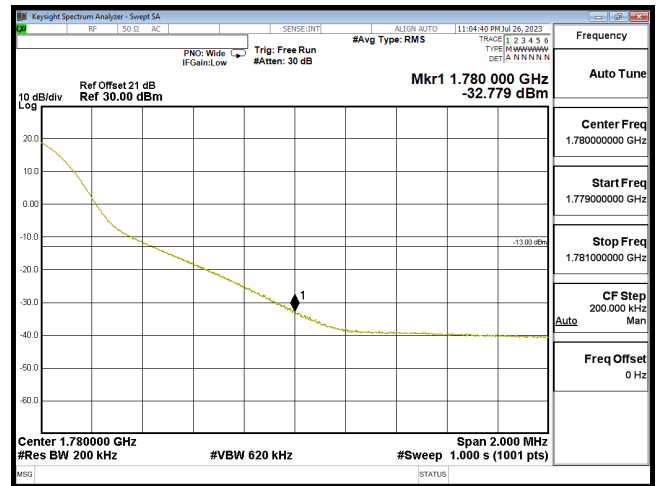

Bandedge B66 20M CH132572 QPSK(1,99)

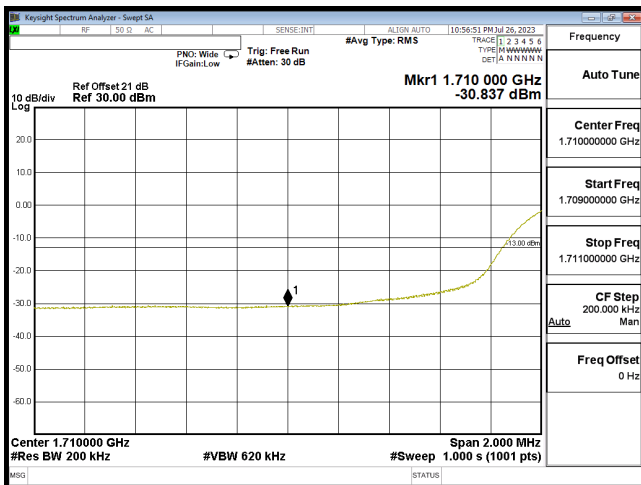

Bandedge B66 20M CH132072 QPSK(100,0)

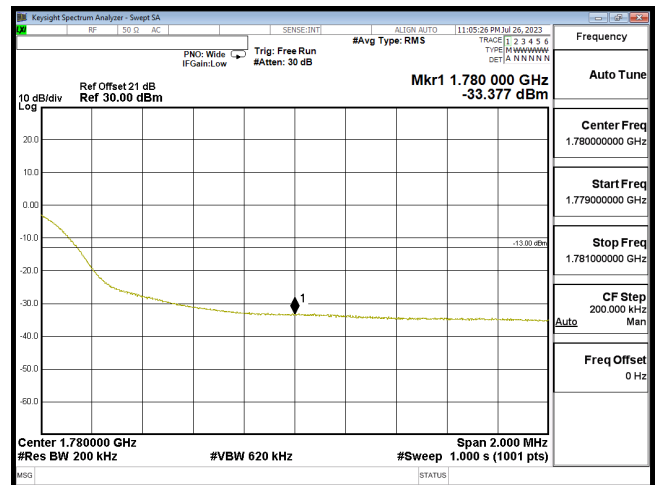

Bandedge B66 20M CH132572 QPSK(100,0)

## 6. Spurious Emission

### 6.1 Test Specification

According to Part 2.1051, 2.1053, 22.917, 24.238, 27.53, RSS-GEN, RSS-130, RSS-132, RSS-133, RSS-139, RSS-199.

### 6.2 Test Setup

#### 6.2.1 Spurious emissions at antenna terminals.

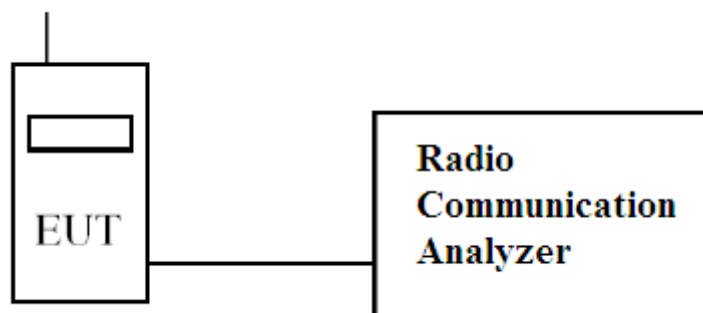

#### 6.2.2 Field strength of spurious radiation.

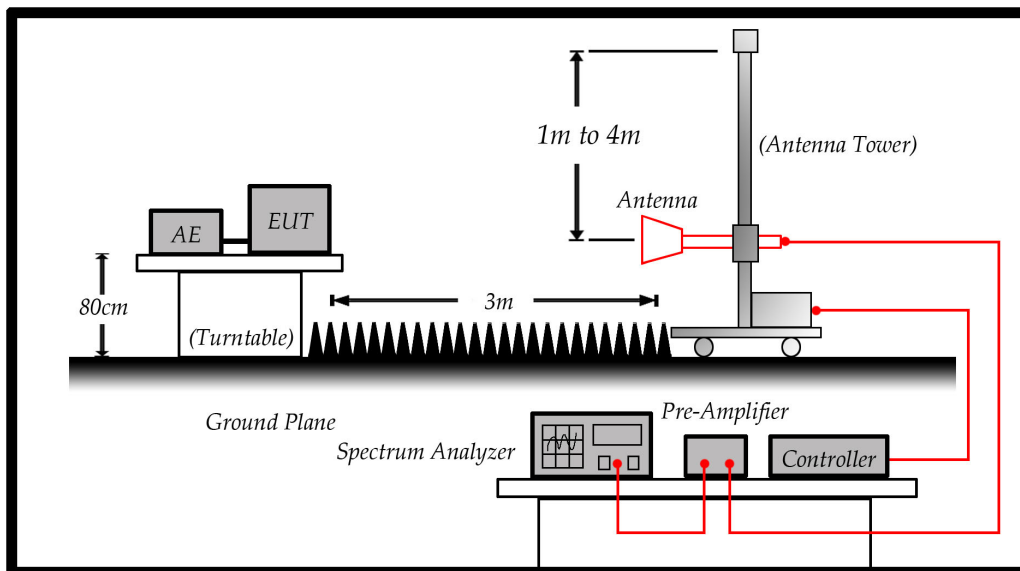

6.3 Limits

<b>Limit</b>	<b>&lt; -13 dBm</b>
--------------	---------------------

43 + 10Log(P) down on the carrier where P is the power in Watts.

For LTE Band 7/38/41:

<b>Limit</b>	<b>&lt; -25 dBm</b>
--------------	---------------------

55 + 10Log(P) down on the carrier where P is the power in Watts.

For LTE Band 13:

<b>Limit</b>	<b>&lt; -13 dBm</b> <b>&lt; -40 dBm</b>
--------------	--

For operations in the 746-758 MHz, 775-788 MHz, and 805-806 MHz bands, emissions in the band 1559-1610 MHz shall be limited to -70 dBW/MHz equivalent isotropically radiated power (EIRP) for wideband signals.

6.4 Test Procedure

In accordance with Part 2.1051, 2.1053, 22.917, 24.238, 27.53, the spurious emissions from the antenna terminal were measured. The transmitter output power was attenuated using a combination of filters and attenuators and the frequency spectrum investigated from 30 MHz to 20 GHz. The EUT was set to transmit on full power. The EUT was tested on Low, middle and High channels for both power levels. The resolution and video bandwidth was set to 1 MHz/3 MHz in accordance with Part 2.1051, 2.1053, 22.917, 24.238, 27.53. The spectrum analyzer detector was set to Max Hold. In addition, measurements were made up to the 10th harmonic of the fundamental. The device was then replaced with a substitution antenna, which input signal was adjusted until the received level matched that of the previously detected emission.

- (1) The EUT is tested with maximum rated TX power via the Base Station simulator.
- (2) The EUT is tested in three orthogonal planes, The worst case was showing in this report.

The EUT is placed on a turn table which is 1.5 meter above ground. The turn table can rotate 360 degrees to determine the position of the maximum emission level. The EUT was positioned such that the distance from antenna to the EUT was 3 meters.

The antenna can move up and down between 1 meter and 4 meters to find out the maximum emission level.

Both horizontal and vertical polarization of the antenna are set on measurement. In order to find the maximum emission, all of the interface cables must be manipulated according to TIA/EIA 603-E on radiated measurement.