



FCC 47 CFR PART 15 SUBPART C

TEST REPORT

For

Cradle

Model: A1010

Trade Name: CIPHERLAB

Issued to

Cipherlab Co., Ltd.

12F, 333 Dunhua S. Rd., Sec.2, Taipei, Taiwan R.O.C.

Issued by

Compliance Certification Services Inc.

No. 81-1, Lane 210, Pa-De 2nd Rd., Luchu Hsiang,

Taoyuan Shien, (338) Taiwan, R.O.C.

<http://www.ccsemc.com.tw>

service@tw.ccsemc.com



Note: This report shall not be reproduced except in full, without the written approval of Compliance Certification Services Inc. This document may be altered or revised by Compliance Certification Services Inc. personnel only, and shall be noted in the revision section of the document.



TABLE OF CONTENTS

- 1. TEST RESULT CERTIFICATION..... 3**
- 2. EUT DESCRIPTION..... 4**
- 3. TEST METHODOLOGY 5**
 - 3.1 EUT CONFIGURATION.....5
 - 3.2 EUT EXERCISE5
 - 3.3 GENERAL TEST PROCEDURES5
 - 3.4 FCC PART 15.205 RESTRICTED BANDS OF OPERATIONS.....6
 - 3.5 DESCRIPTION OF TEST MODES7
- 4. INSTRUMENT CALIBRATION..... 8**
 - 4.1 MEASURING INSTRUMENT CALIBRATION.....8
 - 4.2 MEASUREMENT EQUIPMENT USED.....8
- 5. FACILITIES AND ACCREDITATIONS..... 10**
 - 5.1 FACILITIES 10
 - 5.2 EQUIPMENT 10
 - 5.3 TABLE OF ACCREDITATIONS AND LISTINGS..... 11
- 6. SETUP OF EQUIPMENT UNDER TEST..... 12**
 - 6.1 SETUP CONFIGURATION OF EUT..... 12
 - 6.2 SUPPORT EQUIPMENT..... 12
- 7. FCC PART 15.247 REQUIREMENTS 13**
 - 7.1 PEAK POWER 13
 - 7.2 BAND EDGES MEASUREMENT 14
 - 7.3 FREQUENCY SEPARATION..... 19
 - 7.4 NUMBER OF HOPPING FREQUENCY 22
 - 7.5 TIME OF OCCUPANCY (DWELL TIME)..... 24
 - 7.6 SPURIOUS EMISSIONS..... 31
 - 7.7 POWERLINE CONDUCTED EMISSIONS 42
- APPENDIX I RADIO FREQUENCY EXPOSURE..... 45**
- APPENDIX II PHOTOGRAPHS OF TEST SETUP..... 47**



1. TEST RESULT CERTIFICATION

Applicant: Cipherlab Co., Ltd.
 12F, 333 Dunhua S. Rd., Sec.2, Taipei, Taiwan R.O.C.

Equipment Under Test: Cradle

Trade Name: CIPHERLAB

Model: A1010

Date of Test: September 13 ~ 15, 2007

APPLICABLE STANDARDS	
STANDARD	TEST RESULT
FCC 47 CFR Part 15 Subpart C	No non-compliance noted

We hereby certify that:

The above equipment was tested by Compliance Certification Services Inc. The test data, data evaluation, test procedures, and equipment configurations shown in this report were made in accordance with the procedures given in ANSI C63.4: 2003 and the energy emitted by the sample EUT tested as described in this report is in compliance with the requirements of FCC Rules Part 15.207, 15.209, 15.247.

The test results of this report relate only to the tested sample EUT identified in this report.

Approved by:

Reviewed by:

S.C. Wang
 Executive Vice President
 Compliance Certification Services Inc.

Miller Lee
 Deputy Manager
 Compliance Certification Services Inc.



2. EUT DESCRIPTION

Product	Cradle		
Trade Name	CIPHERLAB		
Model Number	A1010		
Model Discrepancy	N/A		
Power Supply	VDC From Power Adapter		
AC Power Adapter	BALANCE	Model	GPSA-0500255
Power Adapter Power Rating	I/P: 100-240VAC, 50-60Hz, 0.5A O/P: 5VDC, 1A		
RF Module Manufacturer	J-THREE	Model	BM-1023
Frequency Range	2402 ~ 2480 MHz		
Transmit Power	-0.04 dBm		
Modulation Technique	Bluetooth: FHSS (GFSK)		
Transmit Data Rate	1Mbps		
Number of Channels	79 Channels		
Antenna Specification	Chip Antenna / Gain: 3.0dBi		

Remark:

1. The sample selected for test was engineering sample that approximated to production product and was provided by manufacturer.
2. This submittal(s) (test report) is intended for FCC ID: Q3N-A1010 filing to comply with Section 15.207, 15.209 and 15.247 of the FCC Part 15, Subpart C Rules.



3. TEST METHODOLOGY

The tests documented in this report were performed in accordance with ANSI C63.4 and FCC CFR 47 2.1046, 2.1047, 2.1049, 2.1051, 2.1053, 2.1055, 2.1057, 15.207, 15.209 and 15.247.

3.1 EUT CONFIGURATION

The EUT configuration for testing is installed on RF field strength measurement to meet the Commissions requirement and operating in a manner that intends to maximize its emission characteristics in a continuous normal application.

3.2 EUT EXERCISE

The EUT was operated in the engineering mode to fix the TX frequency that was for the purpose of the measurements.

According to its specifications, the EUT must comply with the requirements of the Section 15.207, 15.209 and 15.247 under the FCC Rules Part 15 Subpart C.

3.3 GENERAL TEST PROCEDURES

Conducted Emissions

The EUT is placed on the turntable, which is 0.8 m above ground plane. According to the requirements in Section 13.1.4.1 of ANSI C63.4 Conducted emissions from the EUT measured in the frequency range between 0.15 MHz and 30MHz using CISPR Quasi-peak and average detector modes.

Radiated Emissions

The EUT is placed on a turn table, which is 0.8 m above ground plane. The turntable shall rotate 360 degrees to determine the position of maximum emission level. EUT is set 3m away from the receiving antenna, which varied from 1m to 4m to find out the highest emission. And also, each emission was to be maximized by changing the polarization of receiving antenna both horizontal and vertical. In order to find out the maximum emissions, exploratory radiated emission measurements were made according to the requirements in Section 13.1.4.1 of ANSI C63.4.



3.4 FCC PART 15.205 RESTRICTED BANDS OF OPERATIONS

(a) Except as shown in paragraph (d) of this section, only spurious emissions are permitted in any of the frequency bands listed below:

MHz	MHz	MHz	GHz
0.090 - 0.110	16.42 - 16.423	399.9 - 410	4.5 - 5.15
¹ 0.495 - 0.505	16.69475 - 16.69525	608 - 614	5.35 - 5.46
2.1735 - 2.1905	16.80425 - 16.80475	960 - 1240	7.25 - 7.75
4.125 - 4.128	25.5 - 25.67	1300 - 1427	8.025 - 8.5
4.17725 - 4.17775	37.5 - 38.25	1435 - 1626.5	9.0 - 9.2
4.20725 - 4.20775	73 - 74.6	1645.5 - 1646.5	9.3 - 9.5
6.215 - 6.218	74.8 - 75.2	1660 - 1710	10.6 - 12.7
6.26775 - 6.26825	108 - 121.94	1718.8 - 1722.2	13.25 - 13.4
6.31175 - 6.31225	123 - 138	2200 - 2300	14.47 - 14.5
8.291 - 8.294	149.9 - 150.05	2310 - 2390	15.35 - 16.2
8.362 - 8.366	156.52475 -	2483.5 - 2500	17.7 - 21.4
8.37625 - 8.38675	156.52525	2655 - 2900	22.01 - 23.12
8.41425 - 8.41475	156.7 - 156.9	3260 - 3267	23.6 - 24.0
12.29 - 12.293	162.0125 - 167.17	3332 - 3339	31.2 - 31.8
12.51975 - 12.52025	167.72 - 173.2	3345.8 - 3358	36.43 - 36.5
12.57675 - 12.57725	240 - 285	3600 - 4400	(²)
13.36 - 13.41	322 - 335.4		

¹ Until February 1, 1999, this restricted band shall be 0.490-0.510 MHz.

² Above 38.6

(b) Except as provided in paragraphs (d) and (e), the field strength of emissions appearing within these frequency bands shall not exceed the limits shown in Section 15.209. At frequencies equal to or less than 1000 MHz, compliance with the limits in Section 15.209 shall be demonstrated using measurement instrumentation employing a CISPR quasi-peak detector. Above 1000 MHz, compliance with the emission limits in Section 15.209 shall be demonstrated based on the average value of the measured emissions. The provisions in Section 15.35 apply to these measurements.



3.5 DESCRIPTION OF TEST MODES

The EUT (model: A1010) had been tested under operating condition.

Test program used to control the EUT for staying in continuous transmitting mode was programmed.

After verification, all tests were carried out with the worst case test modes as shown below except radiated spurious emission below 1GHz, which worst case was in normal link mode only.

Channel Low (2402MHz), Mid (2441MHz) and High (2480MHz) were chosen for full testing.



4. INSTRUMENT CALIBRATION

4.1 MEASURING INSTRUMENT CALIBRATION

The measuring equipment, which was utilized in performing the tests documented herein, has been calibrated in accordance with the manufacturer's recommendations for utilizing calibration equipment, which is traceable to recognized national standards.

4.2 MEASUREMENT EQUIPMENT USED

Equipment Used for Emissions Measurement

Remark: Each piece of equipment is scheduled for calibration once a year.

Conducted Emissions Test Site				
Name of Equipment	Manufacturer	Model	Serial Number	Calibration Due
Spectrum Analyzer	R&S	FSP30	100112	10/10/2007

Open Area Test Site # 3				
Name of Equipment	Manufacturer	Model	Serial Number	Calibration Due
Spectrum Analyzer	Agilent	E4411B	MY41440314	N.C.R
Spectrum Analyzer	R&S	FSP30	100112	10/10/2007
EMI Test Receiver	R&S	ESVS30	828488/004	03/12/2008
Pre-Amplifier	Anritsu	MH648A	M18767	09/09/2008
Pre-Amplifier	Agilent	8449B	3008A01738	04/11/2008
Bilog Antenna	SCHWAZBECK	VULB9163	144	03/30/2008
Horn Antenna	EMCO	3115	00022250	05/03/2008
Loop Antenna	EMCO	6502	2356	06/02/2008
Turn Table	Chance Most	CM-T003-1	T807-6	N.C.R
Antenna Tower	Chance Most	CM-A003-1	A807-6	N.C.R
Controller	CCS	CC-C-1F	N/A	N.C.R
RF Switch	ANRITSU	MP59B	M53867	N.C.R
Site NSA	CCS	N/A	N/A	05/18/2008
Test S/W	LabVIEW 6.1 (CCS OATS EMI SW V2.6)			

Remark: The measurement uncertainty is less than +/-2.0065dB (30MHz ~ 1GHz), +/-4.5248dB (Above 1GHz) which is evaluated as per the NAMAS NIS 81 and CISPR/A/291/CDV.



Powerline Conducted Emissions Test Site				
Name of Equipment	Manufacturer	Model	Serial Number	Calibration Due
EMI Test Receiver	SCHAFFNER	SCR 3501	410	12/12/2007
LISN	FCC	FCC-LISN-50/25 0-16-2-07	06013	10/08/2007
LISN	FCC	FCC-LISN-50/25 0-16-2-07	06012	10/08/2007
ISN	FCC	FCC-TLISN-T4	20065	05/07/2007
Test S/W	LabVIEW 6.1 (CCS Conduction Test SW Version_01)			

Remark: The measurement uncertainty is less than +/- 2.81dB, which is evaluated as per the NAMAS NIS 81 and CISPR/A/291/CDV.



5. FACILITIES AND ACCREDITATIONS

5.1 FACILITIES

All measurement facilities used to collect the measurement data are located at

No.199, Chunghsen Road, Hsintien City, Taipei Hsien, Taiwan, R.O.C.

Tel: 886-2-2217-0894 / Fax: 886-2-2217-1029

No.11, Wugong 6th Rd., Wugu Industrial Park, Taipei Hsien 248, Taiwan

Tel: 886-2-2299-9720 / Fax: 886-2-2298-4045

No.81-1, Lane 210, Pa-De 2nd Rd., Luchu Hsiang, Taoyuan Shien 338, Taiwan

Tel: 886-3-324-0332 / Fax: 886-3-324-5235

The sites are constructed in conformance with the requirements of ANSI C63.7, ANSI C63.4 and CISPR Publication 22.

5.2 EQUIPMENT







Radiated emissions are measured with one or more of the following types of linearly polarized antennas: tuned dipole, biconical, log periodic, bi-log, and/or ridged waveguide, horn. Spectrum analyzers with pre-selectors and quasi-peak detectors are used to perform radiated measurements.

Conducted emissions are measured with Line Impedance Stabilization Networks and EMI Test Receivers.

Calibrated wideband preamplifiers, coaxial cables, and coaxial attenuators are also used for making measurements.

All receiving equipment conforms to CISPR Publication 16-1, "Radio Interference Measuring Apparatus and Measurement Methods."

5.3 TABLE OF ACCREDITATIONS AND LISTINGS

Country	Agency	Scope of Accreditation	Logo
USA	A2LA	EN 55011, EN 55014-1/2, CISPR 11, CISPR 14-1/2, EN 55022, EN 55015, CISPR 22, CISPR 15, AS/NZS 3548, VCCI V3 (2001), CFR 47, FCC Part 15/18, CNS 13783-1, CNS 13439, CNS 13438, CNS 13803, CNS 14115, EN 55024, IEC 801-2, IEC 801-3, IEC 801-4, IEC/EN 61000-3-2, IEC/EN 61000-3-3, IEC/EN 61000-4-2/3/4/5/6/8/11, EN 50081-1/EN 61000-6-3, EN 50081-2/EN 61000-6-4, EN 50081-2/EN 61000-6-1: 2001	 ACCREDITED No. 0824-01
USA	FCC	3/10 meter Open Area Test Sites to perform FCC Part 15/18 measurements	 93105, 90471
Japan	VCCI	3/10 meter Open Area Test Sites and conducted test sites to perform radiated/conducted measurements	 R-2451/2316/725/1868 C-402/747/912
Norway	NEMKO	EN 50081-1/2, EN 50082-1/2, IEC 61000-6-1/2, EN 50091-2, EN 50130-4, EN 55011, EN 55013, EN 55014-1/2, EN 55015, EN 55022, EN 55024, EN 61000-3-2/3, EN 61326-1, IEC 61000-4-2/3/4/5/6/8/11, EN 60601-1-2, EN 300 328-2, EN 300 422-2, EN 301 419-1, EN 301 489-01/03/07/08/09/17, EN 301 419-2/3, EN 300 454-2, EN 301 357-2	 ELA 124a ELA 124b ELA 124c
Taiwan	TAF	EN 300 328-1, EN 300 328-2, EN 300 220-1, EN 300 220-2, EN 300 220-3, 47 CFR FCC Part 15 Subpart C, EN 61000-3-2, EN 61000-3-3, CNS 13439, CNS 13783-1, CNS 14115, CNS 13438, AS/NZS CISPR 22, CNS 13022-1, IEC 61000-4-2/3/4/5/6/8/11, CNS 13022-2/3	 Testing Laboratory 8363
Taiwan	BSMI	CNS 13438, CNS 13783-1, CNS 13439, CNS 14115	 SL2-IS-E-0014 / IN-E-0014 /A1-E-0014 /R1-E-0014 /R2-E-0014 /L1-E-0014
Canada	Industry Canada	RSS212, Issue 1	 IC 2324C-3 IC 2324C-5

* No part of this report may be used to claim or imply product endorsement by A2LA or any agency of the US Government.



6. SETUP OF EQUIPMENT UNDER TEST

6.1 SETUP CONFIGURATION OF EUT

See test photographs attached in Appendix II for the actual connections between EUT and support equipment.

6.2 SUPPORT EQUIPMENT

No.	Device Type	Brand	Model	Series No.	FCC ID	Data Cable	Power Cord
1.	Notebook PC	IBM	1706-A78	V-L1870 06/09	FCC DoC	N/A	AC I/P: Unshielded, 1.8m DC O/P: Unshielded, 1.8m
2.	USB Mouse	HP	MO19UCA	20509310	FCC DoC	Unshielded, 1.8m	N/A

Remark: Grounding was established in accordance with the manufacturer's requirements and conditions for the intended use.

7. FCC PART 15.247 REQUIREMENTS

7.1 PEAK POWER

LIMIT

The maximum peak output power of the intentional radiator shall not exceed the following:

1. According to §15.247(a)(1), Frequency hopping systems shall have hopping channel carrier frequencies separated by a minimum of 25 kHz or the 20 dB bandwidth of the hopping channel, whichever is greater. Alternatively, frequency hopping systems operating in the 2400-2483.5 MHz band may have hopping channel carrier frequencies that are separated by 25 kHz or two-thirds of the 20 dB bandwidth of the hopping channel, whichever is greater, provided the systems operate with an output power no greater than 125 mW.
2. According to §15.247(b)(3), for systems using digital modulation in the bands of 902-928 MHz, 2400-2483.5 MHz, and 5725-5850 MHz: 1 Watt.
3. According to §15.247(b)(4), the conducted output power limit specified in paragraph (b) of this section is based on the use of antennas with directional gains that do not exceed 6 dBi. Except as shown in paragraph (c) of this section, if transmitting antennas of directional gain greater than 6 dBi are used, the conducted output power from the intentional radiator shall be reduced below the stated values in paragraphs (b)(1), (b)(2), and (b)(3) of this section, as appropriate, by the amount in dB that the directional gain of the antenna exceeds 6 dBi.

Test Configuration

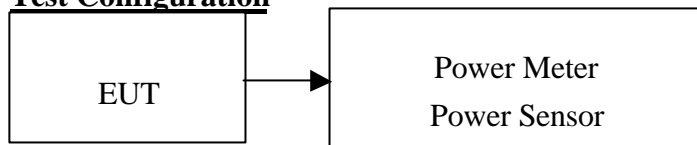

TEST PROCEDURE

The transmitter output is connected to the Power Meter. The Power Meter is set to the peak power detection.

TEST RESULTS

No non-compliance noted

Test Data

Channel	Frequency (MHz)	Output Power (dBm)	Output Power (W)	Limit (W)	Result
Low	2402	-2.86	0.000518	1	PASS
Mid	2441	-1.37	0.000729		PASS
High	2480	-0.04	0.000991		PASS

7.2 BAND EDGES MEASUREMENT

LIMIT

According to §15.247(d), in any 100 kHz bandwidth outside the frequency bands in which the spread spectrum intentional radiator is operating, the radio frequency power that is produced by the intentional radiator shall be at least 20 dB below that in the 100 kHz bandwidth within the band that contains the highest level of the desired power, based on either an RF conducted or a radiated measurement, provided the transmitter demonstrates compliance with the peak conducted power limits. In addition, radiated emissions which fall in the restricted bands, as defined in §15.205(a), must also comply with the radiated emission limits specified in 15.209(a) (see Section 15.205(c)).

Test Configuration

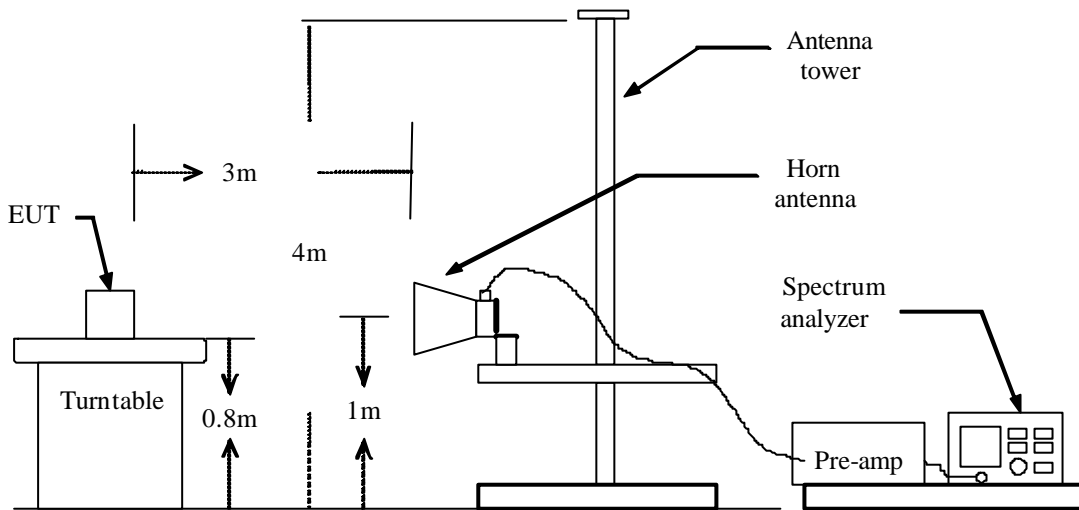

TEST PROCEDURE

1. The EUT is placed on a turntable, which is 0.8m above the ground plane.
2. The turntable shall be rotated for 360 degrees to determine the position of maximum emission level.
3. EUT is set 3m away from the receiving antenna, which is varied from 1m to 4m to find out the highest emission.
4. Set the spectrum analyzer in the following setting in order to capture the lower and upper band-edges of the emission:
 - (a) PEAK: RBW=VBW=1MHz / Sweep=AUTO
 - (b) AVERAGE: RBW=1MHz / VBW=10Hz / Sweep=AUTO
5. Repeat the procedures until all the PEAK and AVERAGE versus POLARIZATION are measured.

TEST RESULTS

Refer to attach spectrum analyzer data chart.



Band Edges (CH Low)

Detector mode: Peak

Polarity: Vertical

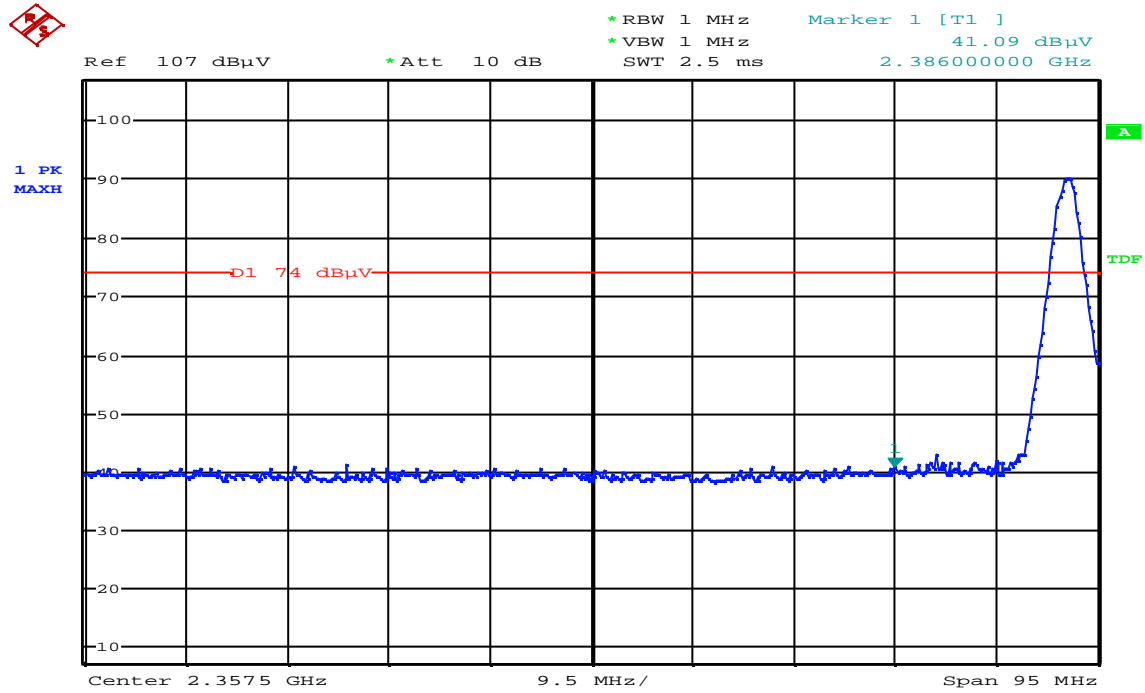

Date: 13.SEP.2007 13:55:25

Detector mode: Average

Polarity: Vertical

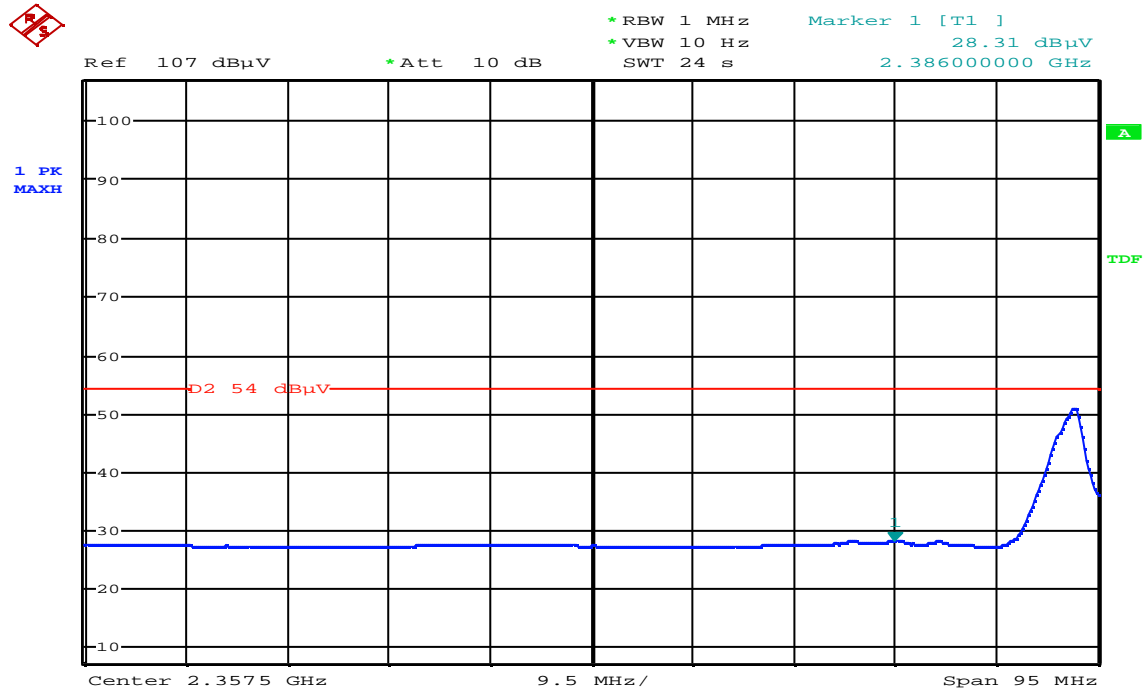

Date: 13.SEP.2007 13:56:21



Detector mode: Peak

Polarity: Horizontal

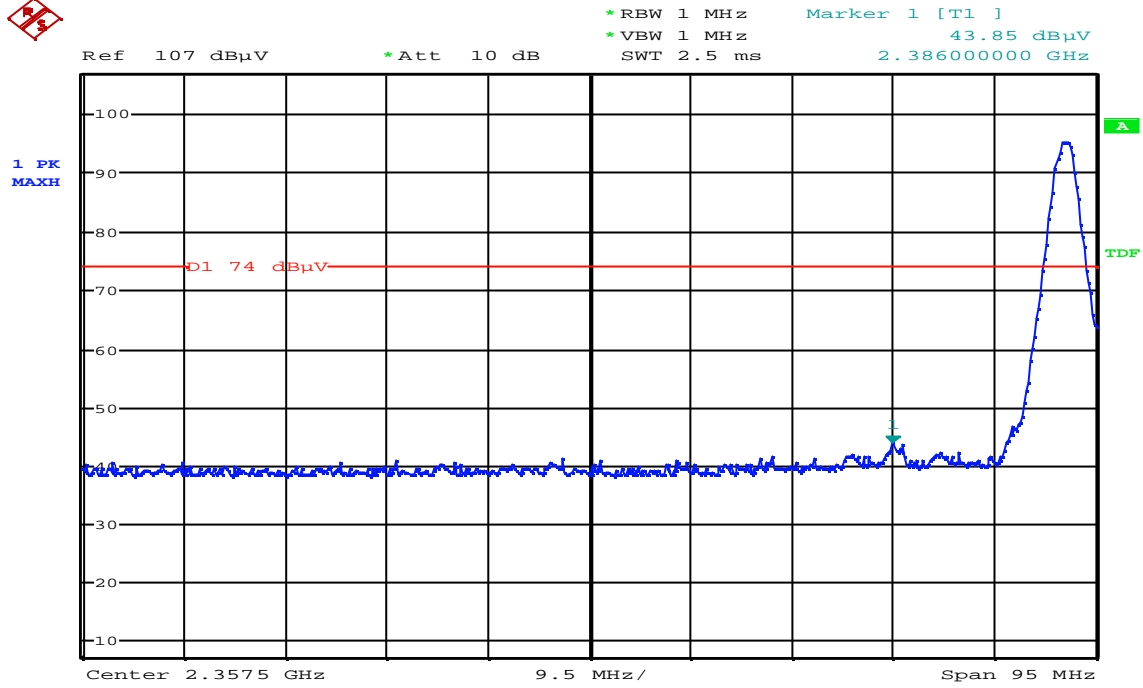

Date: 13.SEP.2007 13:51:46

Detector mode: Average

Polarity: Horizontal

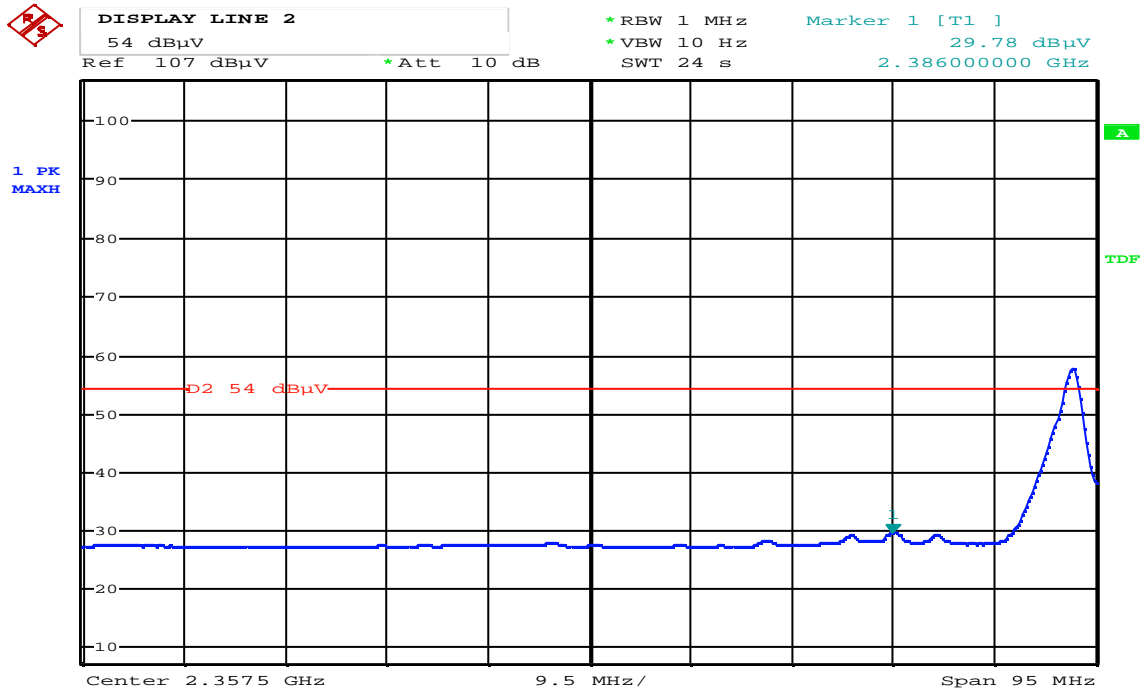

Date: 13.SEP.2007 13:52:41



Band Edges (CH High)

Detector mode: Peak

Polarity: Vertical

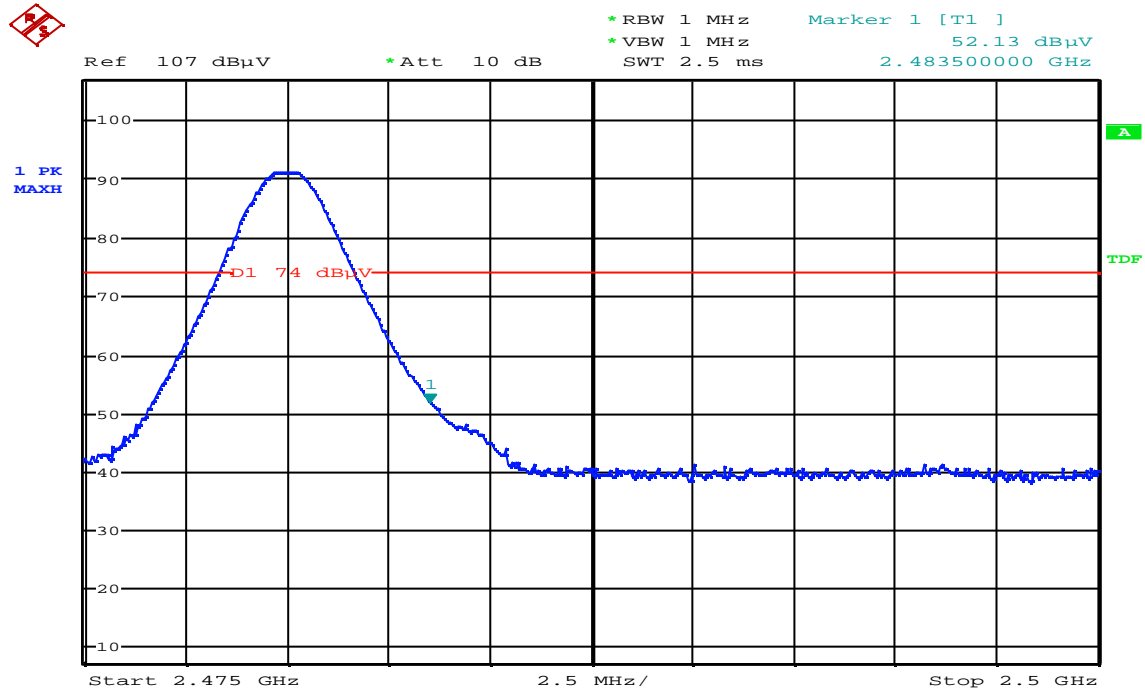

Date: 13.SEP.2007 14:11:28

Detector mode: Average

Polarity: Vertical

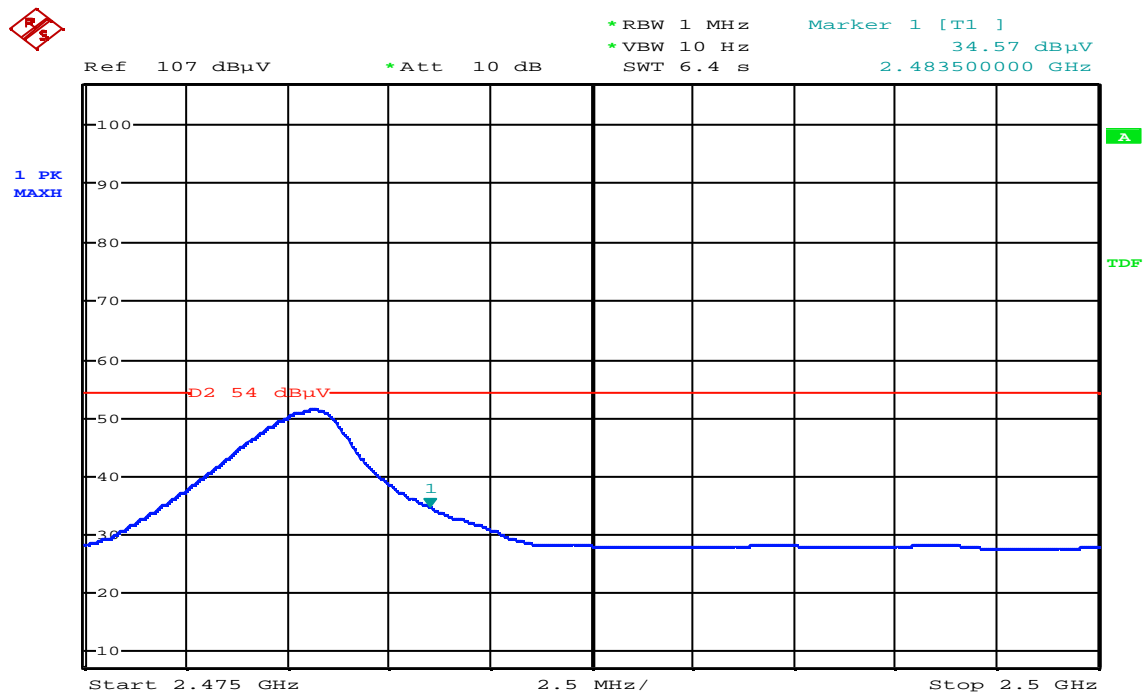

Date: 13.SEP.2007 14:12:19



Detector mode: Peak

Polarity: Horizontal

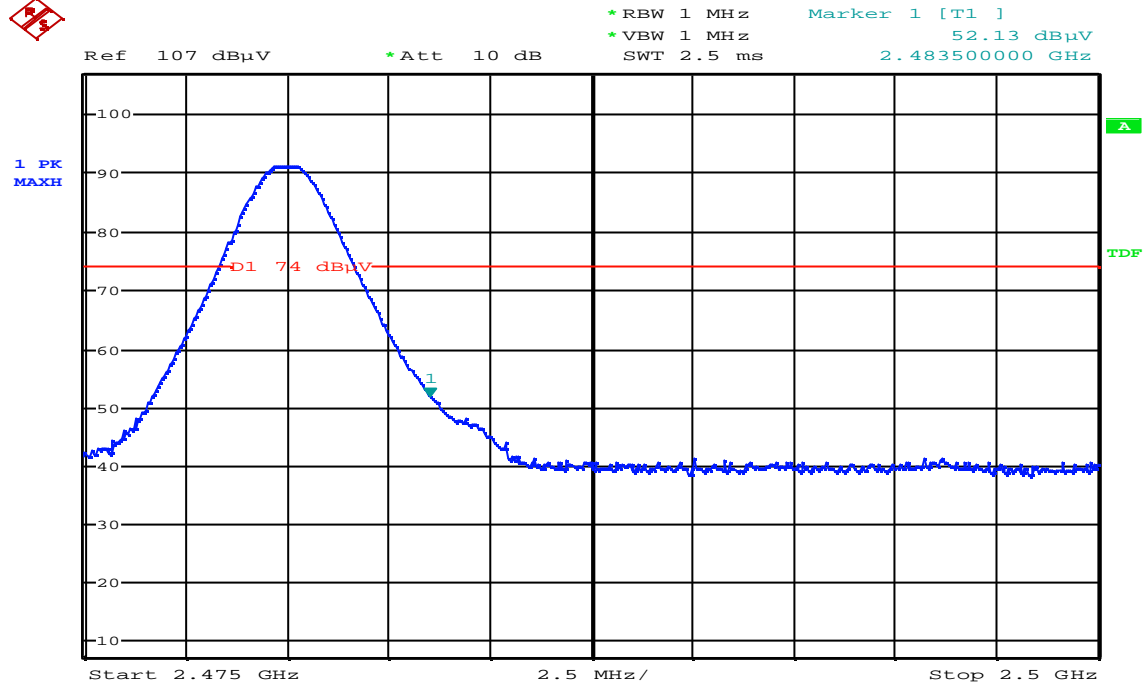

Date: 13.SEP.2007 14:11:28

Detector mode: Average

Polarity: Horizontal

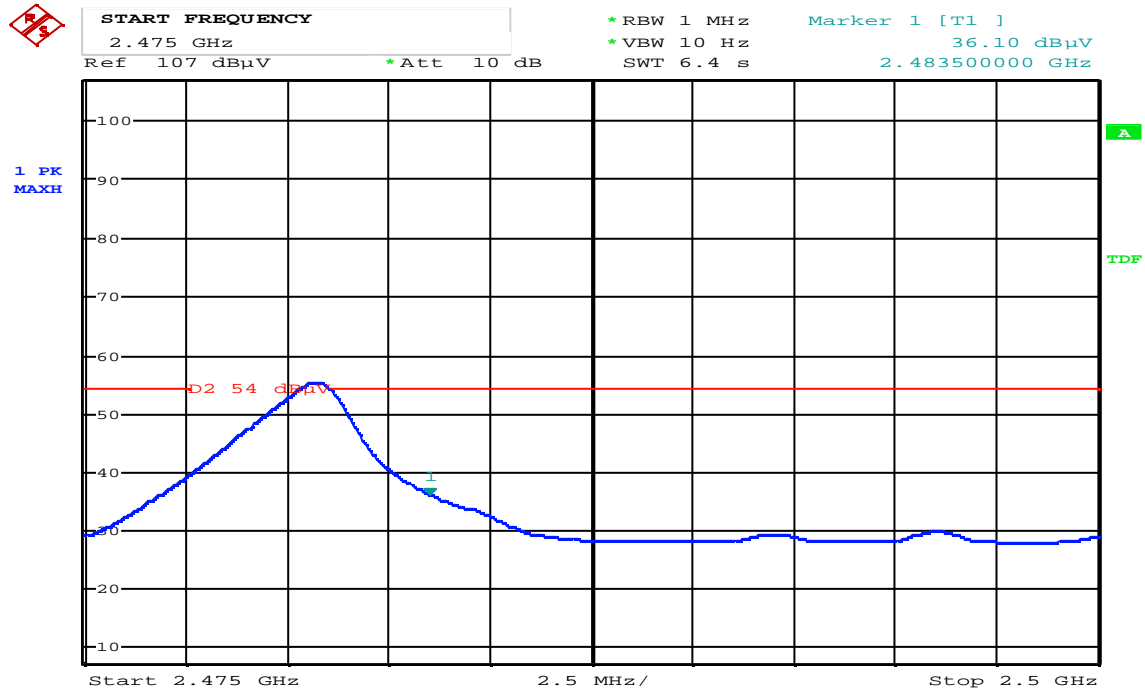

Date: 13.SEP.2007 14:20:32

7.3 FREQUENCY SEPARATION

LIMIT

According to §5.247(a)(1), Frequency hopping systems shall have hopping channel carrier frequencies separated by a minimum of 25 kHz or the 20 dB bandwidth of the hopping channel, whichever is greater. Alternatively, frequency hopping systems operating in the 2400-2483.5 MHz band may have hopping channel carrier frequencies that are separated by 25 kHz or two-thirds of the 20 dB bandwidth of the hopping channel, whichever is greater, provided the systems operate with an output power no greater than 125 mW.

Test Configuration

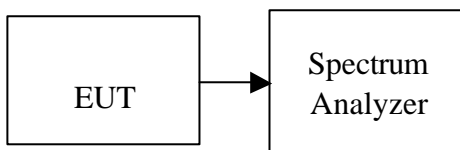

TEST PROCEDURE

1. Place the EUT on the table and set it in transmitting mode.
2. Remove the antenna from the EUT and then connect a low loss RF cable from the antenna port to the spectrum analyzer.
3. Set center frequency of spectrum analyzer = middle of hopping channel.
4. Set the spectrum analyzer as RBW = 30kHz, VBW = 100kHz, Span = 3MHz, Sweep = auto.
5. Max hold, mark 3 peaks of hopping channel and record the 3 peaks frequency.

TEST RESULTS

No non-compliance noted

Test Data

Channel Separation (MHz)	20dB Bandwidth (kHz)	Channel Separation Limit	Result
1.00	949	> 20dB Bandwidth	Pass



Test Plot

Measurement of Channel Separation

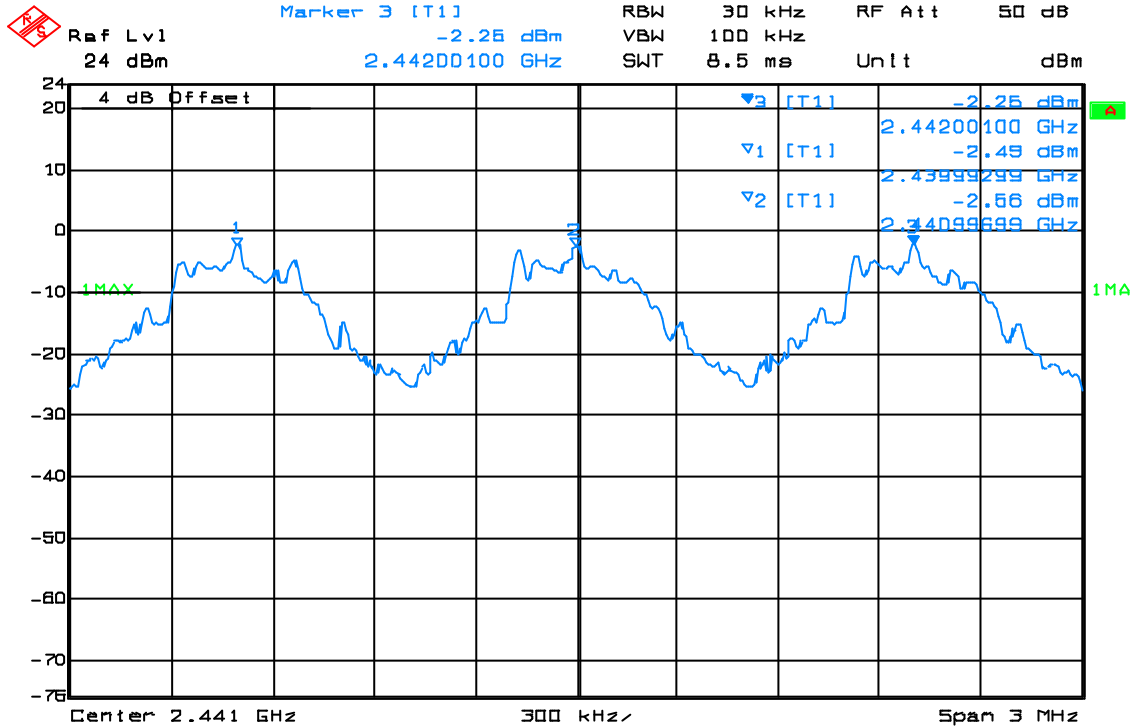

Date: 14.SEP.2007 02:53:11

Measurement of 20dB Bandwidth

CH Low

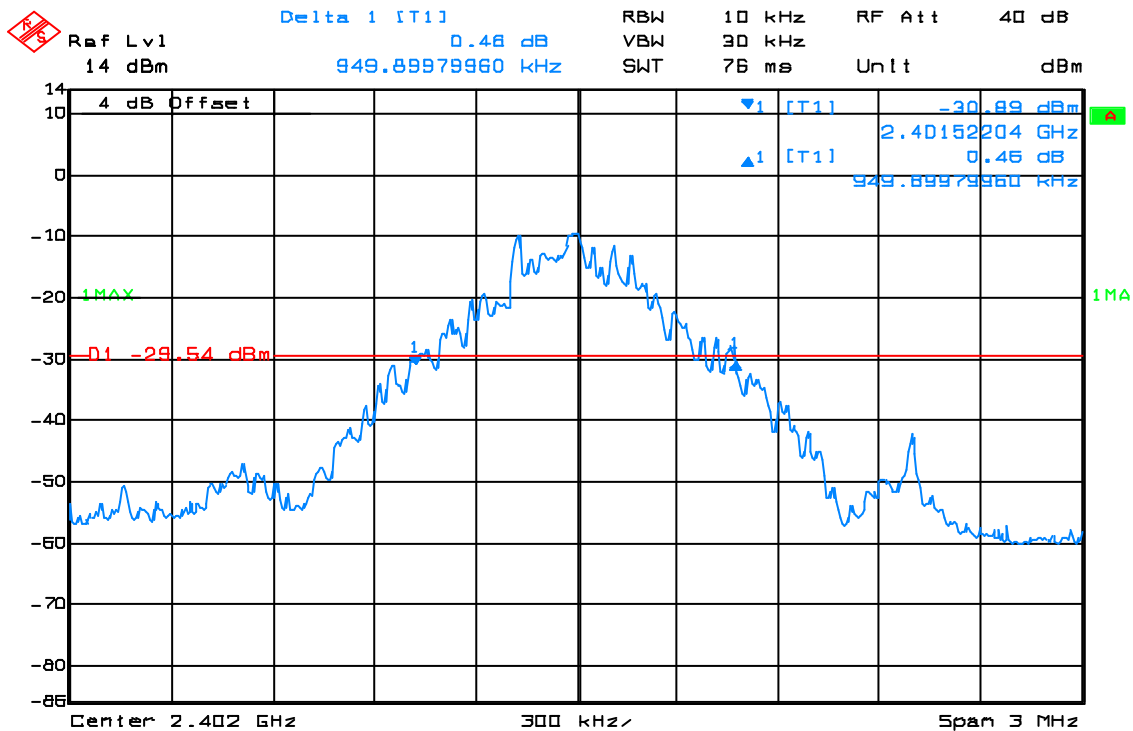

Date: 14.SEP.2007 02:29:46



CH Mid

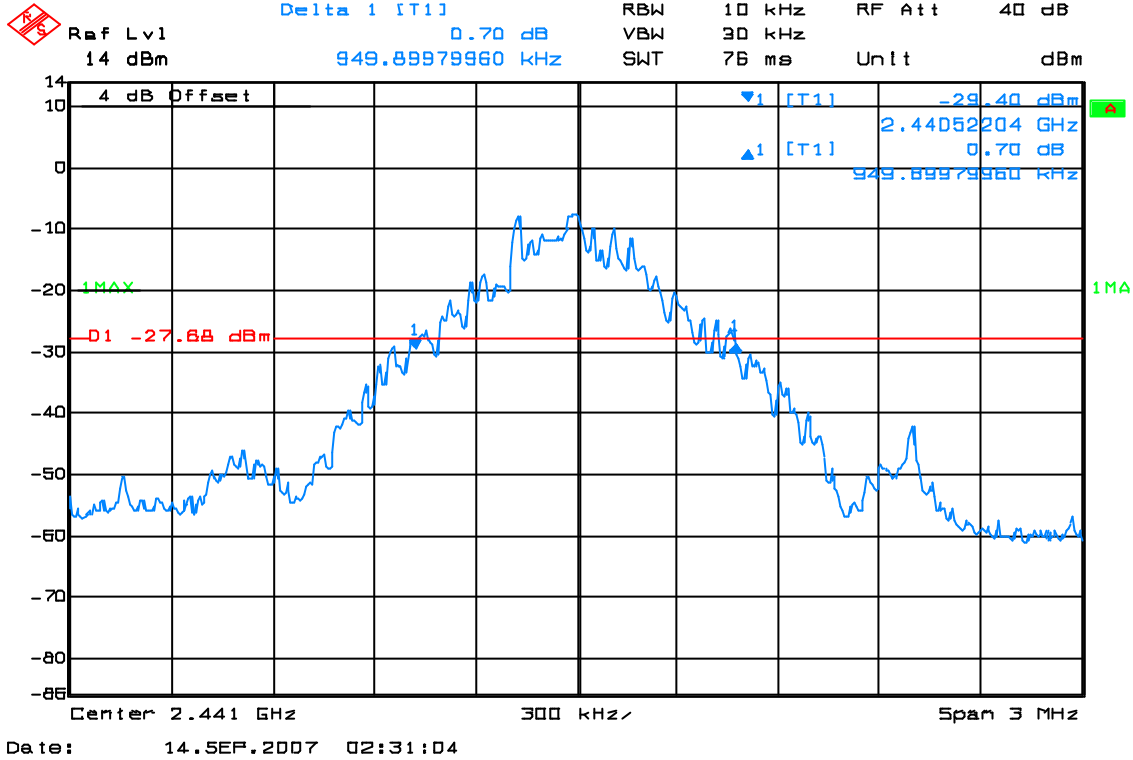

CH High

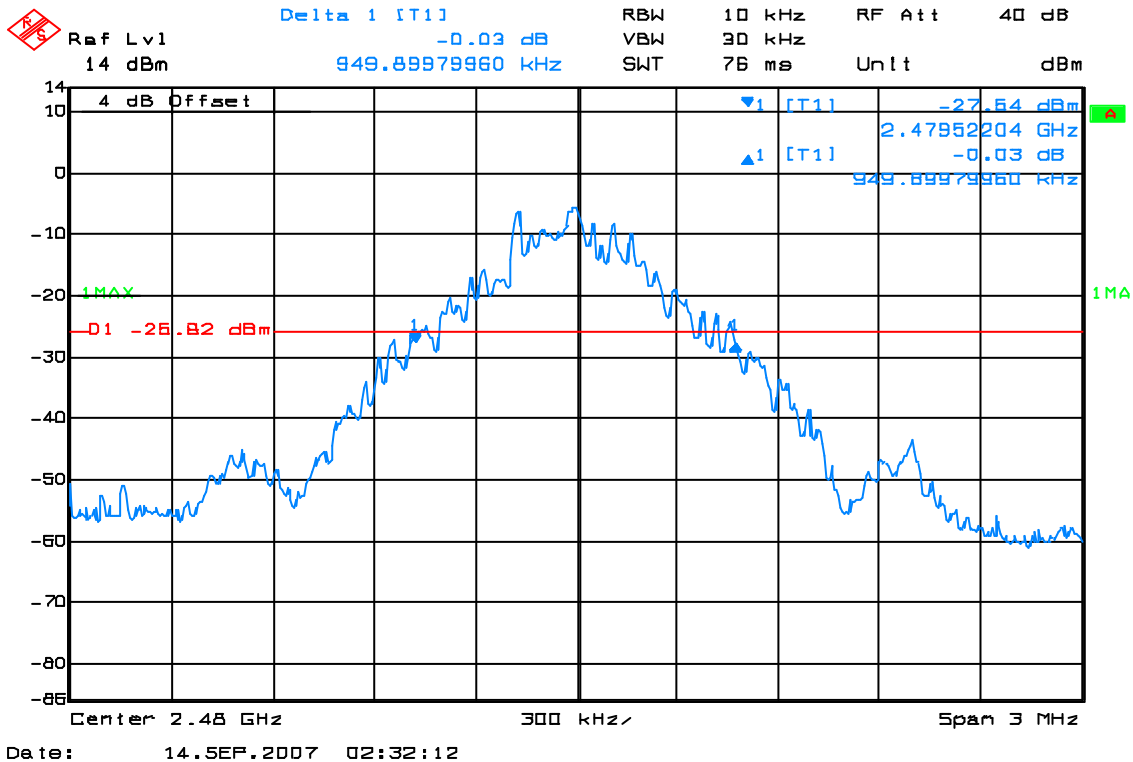

7.4 NUMBER OF HOPPING FREQUENCY

LIMIT

According to §15.247 (1)(iii), Frequency hopping systems operating in the 2400MHz-2483.5 MHz bands shall use at least 15 hopping.

Test Configuration

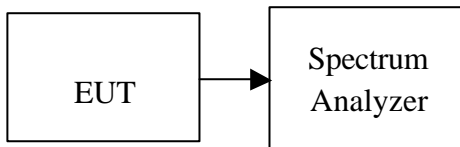

TEST PROCEDURE

1. Place the EUT on the table and set it in transmitting mode.
2. Remove the antenna from the EUT and then connect a low loss RF cable from the antenna port to the spectrum analyzer.
3. Set spectrum analyzer Start=2400MHz, Stop = 2441.5MHz, Sweep = auto and Start=2441.5MHz, Stop = 2483.5MHz, Sweep = auto.
4. Set the spectrum analyzer as RBW, VBW=300kHz.
5. Max hold, view and count how many channel in the band.

TEST RESULTS

No non-compliance noted

Test Data

Result (No. of CH)	Limit (No. of CH)	Result
79	>75	PASS



Test Plot

Channel Number

2.4 GHz – 2.4415 GHz

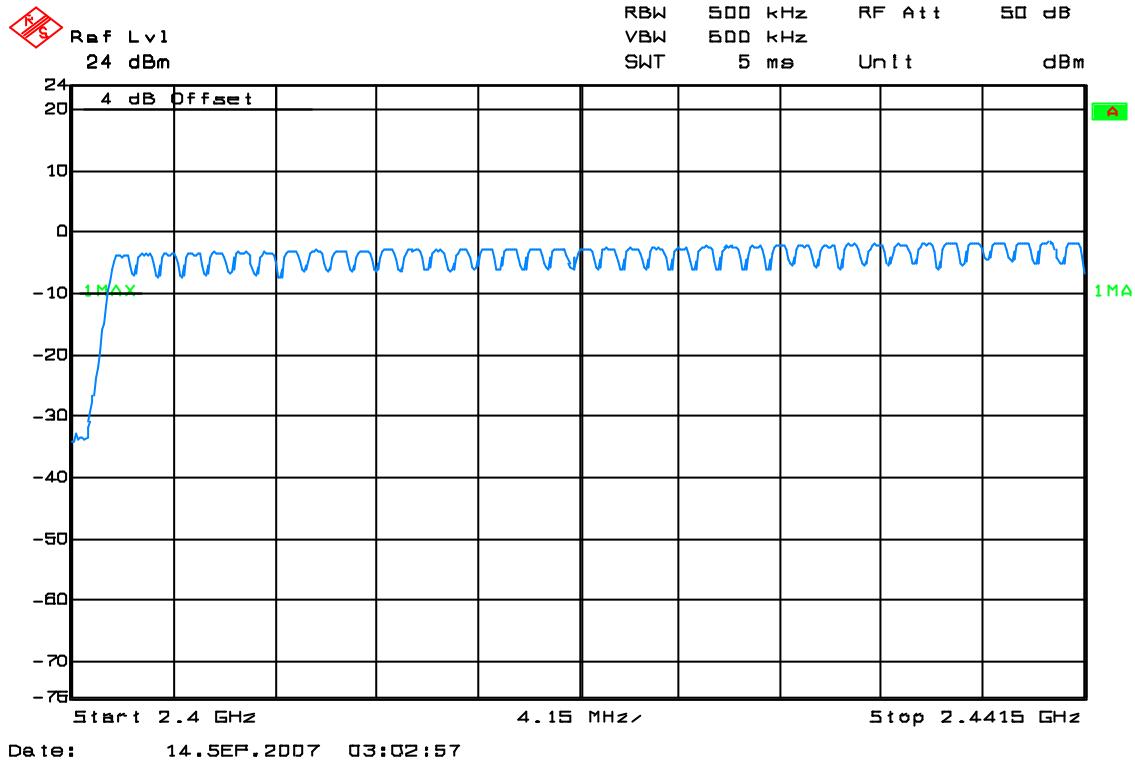

2.4415 GHz – 2.4835 GHz

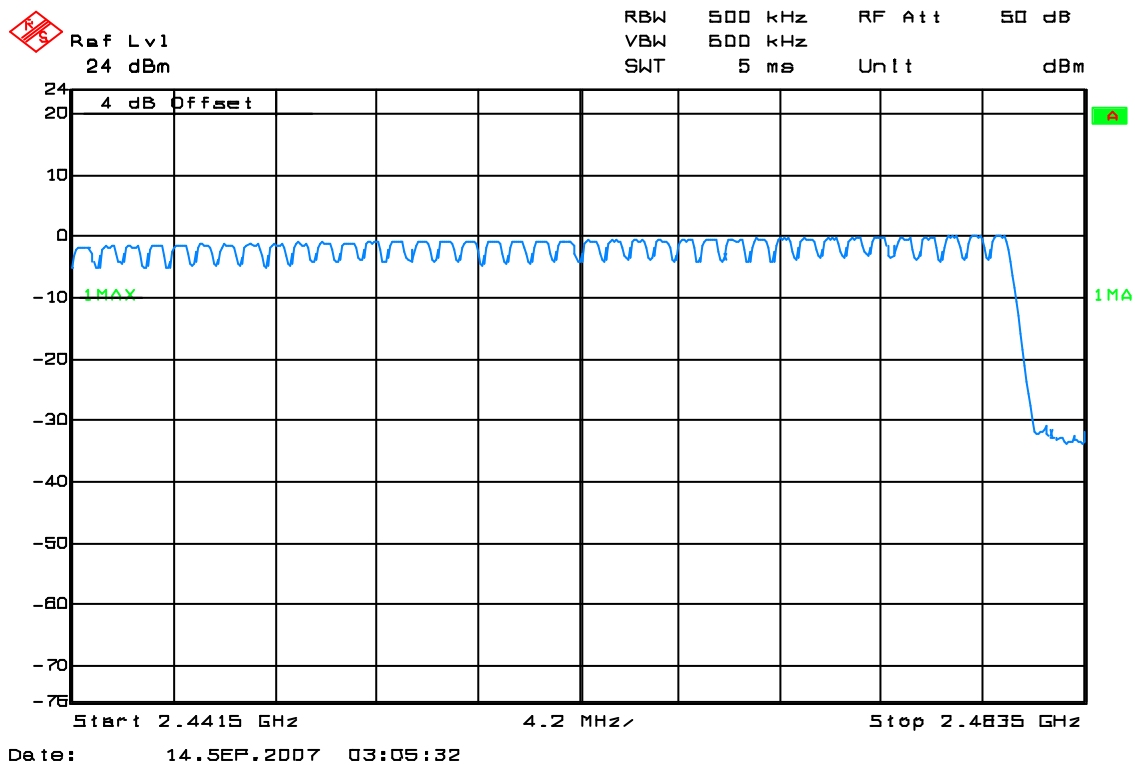

7.5 TIME OF OCCUPANCY (DWELL TIME)

LIMIT

According to §5.247(a)(1)(iii), Frequency hopping systems operating in the 2400MHz-2483.5 MHz bands. The average time of occupancy on any channels shall not greater than 0.4 s within a period 0.4 s multiplied by the number of hopping channels employed.

Test Configuration

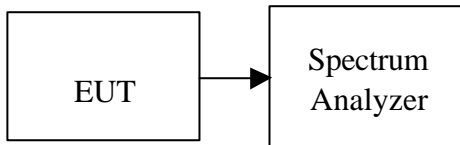

TEST PROCEDURE

1. Place the EUT on the table and set it in transmitting mode.
2. Remove the antenna from the EUT and then connect a low loss RF cable from the antenna port to the spectrum analyzer.
3. Set center frequency of spectrum analyzer = operating frequency.
4. Set the spectrum analyzer as RBW, VBW=1 MHz, Span = 0Hz, Sweep = auto.
5. Repeat above procedures until all frequency measured were complete.



TEST RESULTS

No non-compliance noted

Test Data

DH 1

CH Low: $0.3872 * (1600/2)/79 * 31.6 = 123.90$ (ms)

CH Mid: $0.3780 * (1600/2)/79 * 31.6 = 120.93$ (ms)

CH High: $0.3919 * (1600/2)/79 * 31.6 = 125.41$ (ms)

CH	Pulse Time (ms)	Total of Dwell (ms)	Period Time (s)	Limit (ms)	Result
Low	0.3872	123.904	31.60	400.00	PASS
Mid	0.3780	120.960	31.60		PASS
High	0.3919	125.408	31.60		PASS

DH 3

CH Low: $1.6543 * (1600/4)/79 * 31.6 = 264.69$ (ms)

CH Mid: $1.6442 * (1600/4)/79 * 31.6 = 263.07$ (ms)

CH High: $1.6543 * (1600/4)/79 * 31.6 = 264.69$ (ms)

CH	Pulse Time (ms)	Total of Dwell (ms)	Period Time (s)	Limit (ms)	Result
Low	1.6543	264.688	31.60	400.00	PASS
Mid	1.6442	263.072	31.60		PASS
High	1.6543	264.688	31.60		PASS

DH 5

CH Low: $2.8976 * (1600/6)/79 * 31.6 = 309.08$ (ms)

CH Mid: $2.9164 * (1600/6)/79 * 31.6 = 311.08$ (ms)

CH High: $2.9164 * (1600/6)/79 * 31.6 = 311.08$ (ms)

CH	Pulse Time (ms)	Total of Dwell (ms)	Period Time (s)	Limit (ms)	Result
Low	2.8976	309.077	31.60	400.00	PASS
Mid	2.9164	311.083	31.60		PASS
High	2.9164	311.083	31.60		PASS



Test Plot

DH 1

(CH Low)

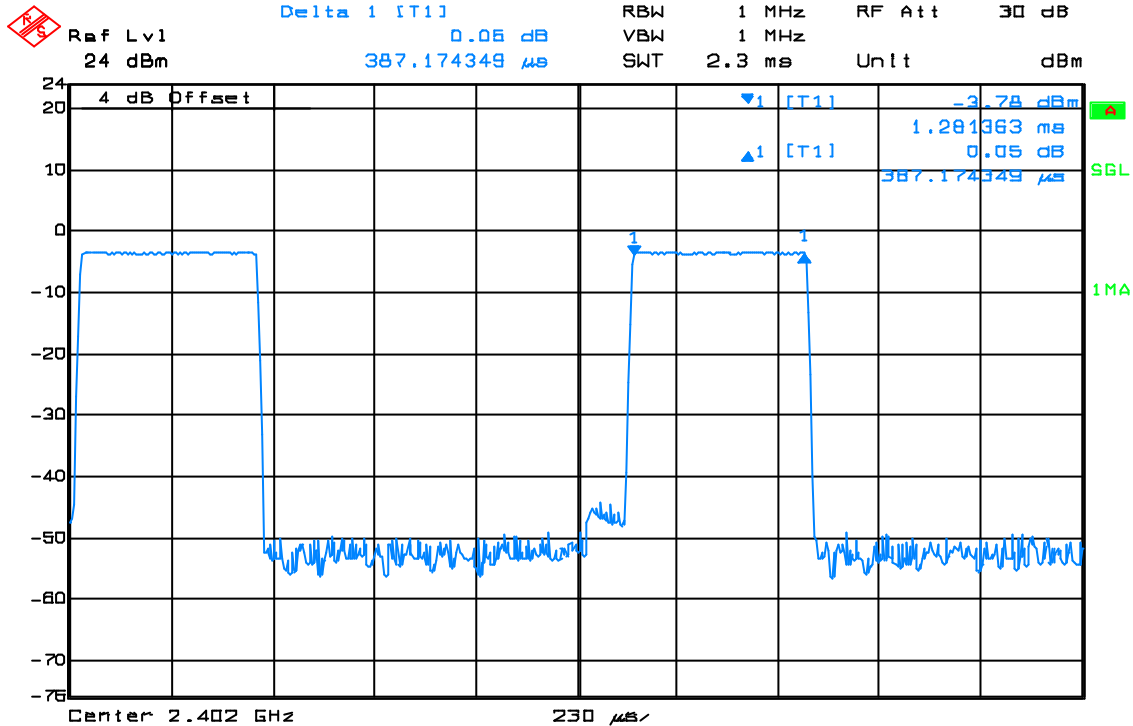

Date: 14.SEP.2007 04:09:43

(CH Mid)

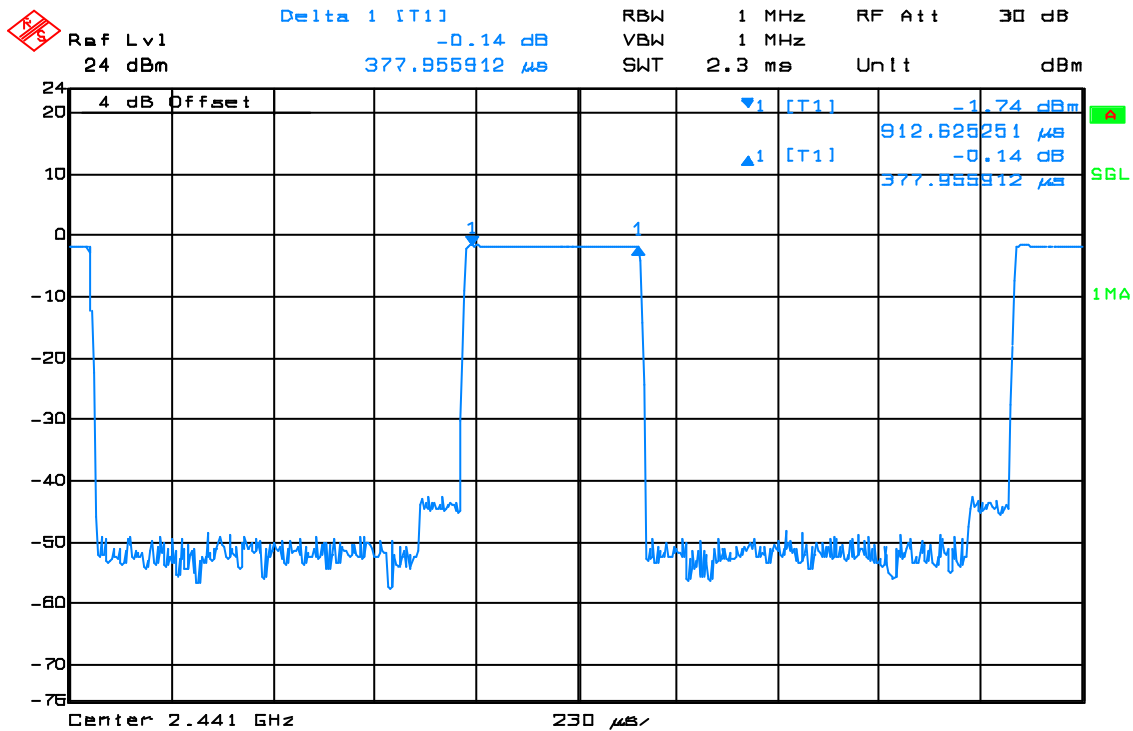

Date: 14.SEP.2007 04:11:24



(CH High)

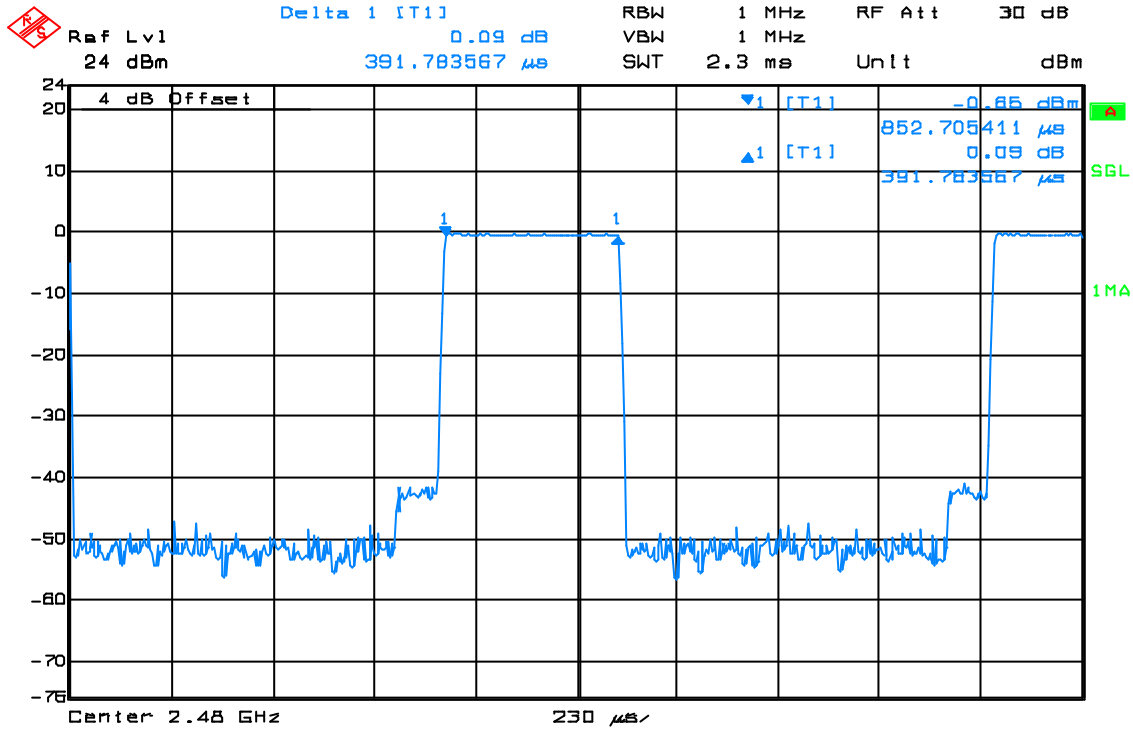

Date: 14.SEP.2007 04:12:42

DH 3

(CH Low)

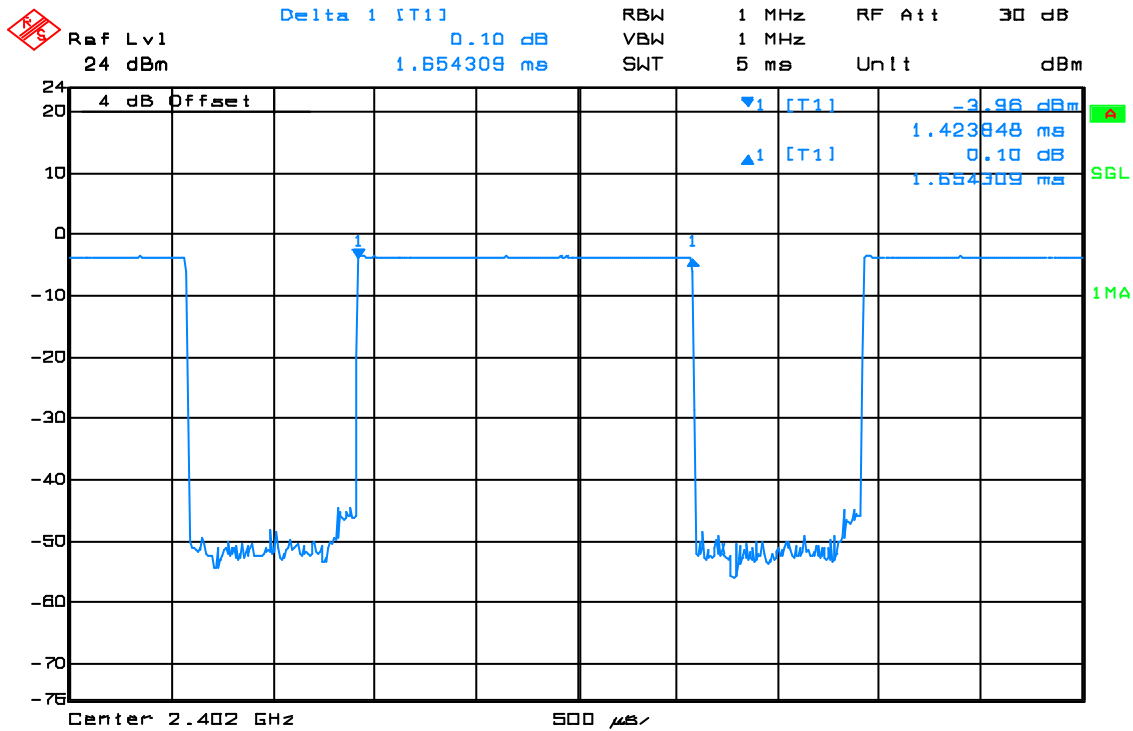

Date: 14.SEP.2007 04:17:20



(CH Mid)

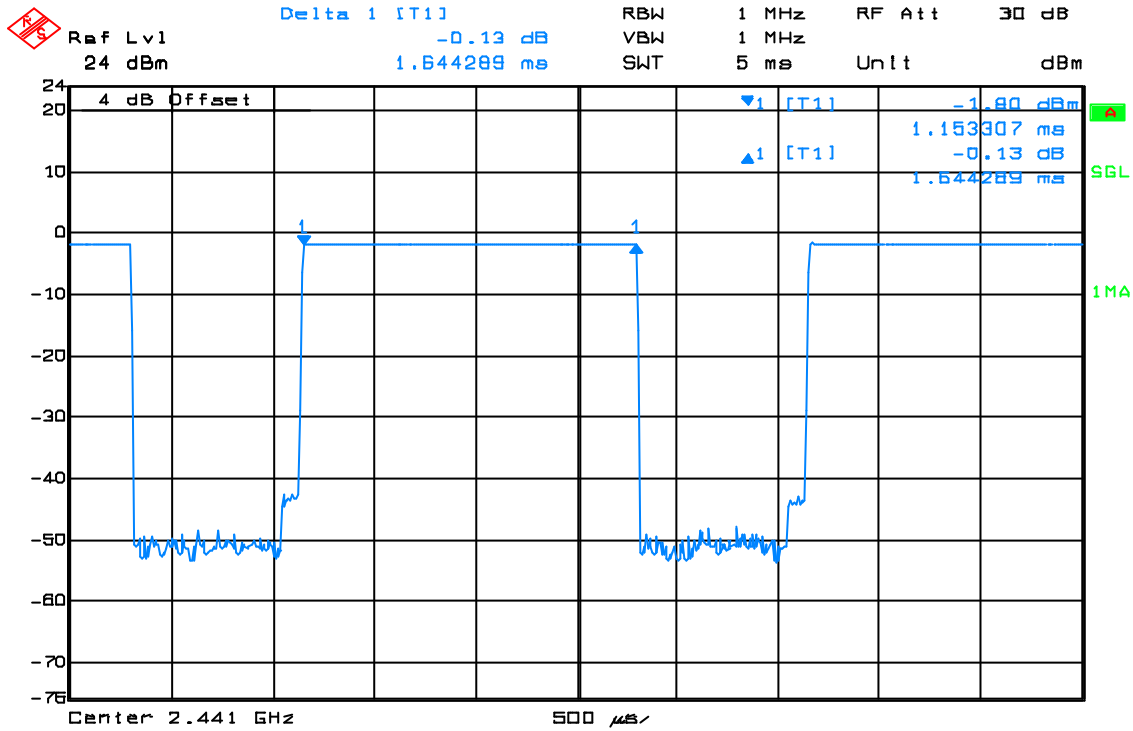

Date: 14.SEP.2007 04:16:22

(CH High)

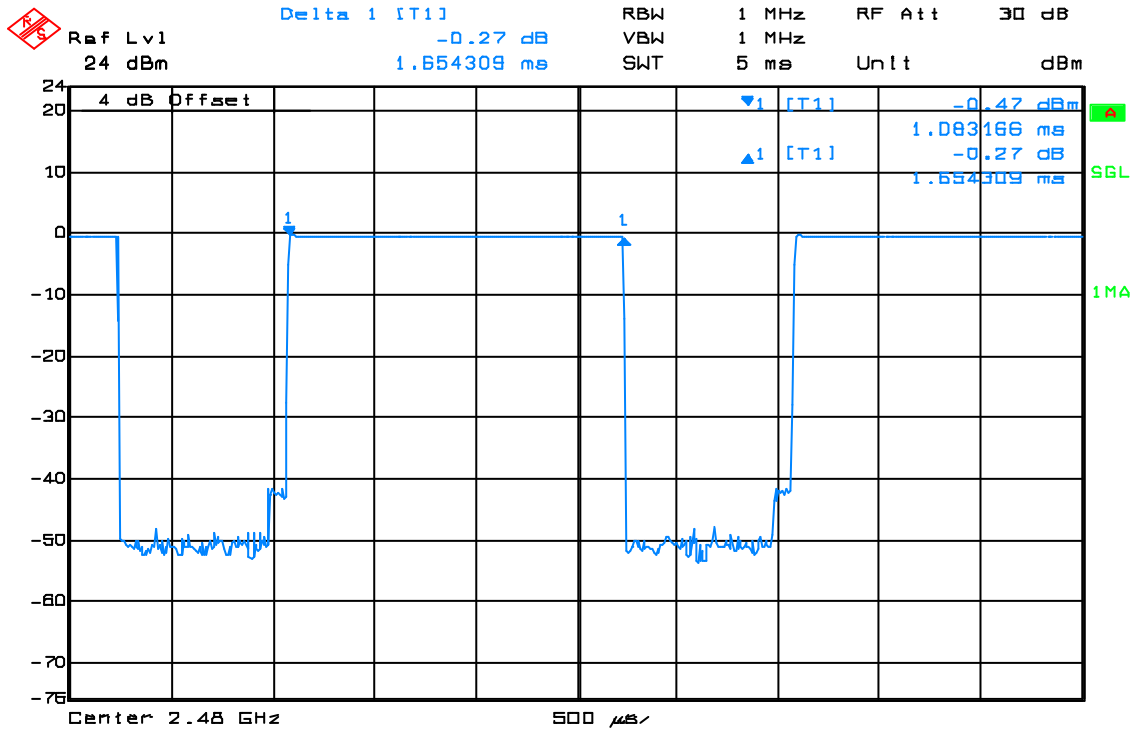

Date: 14.SEP.2007 04:15:28



DH 5

(CH Low)

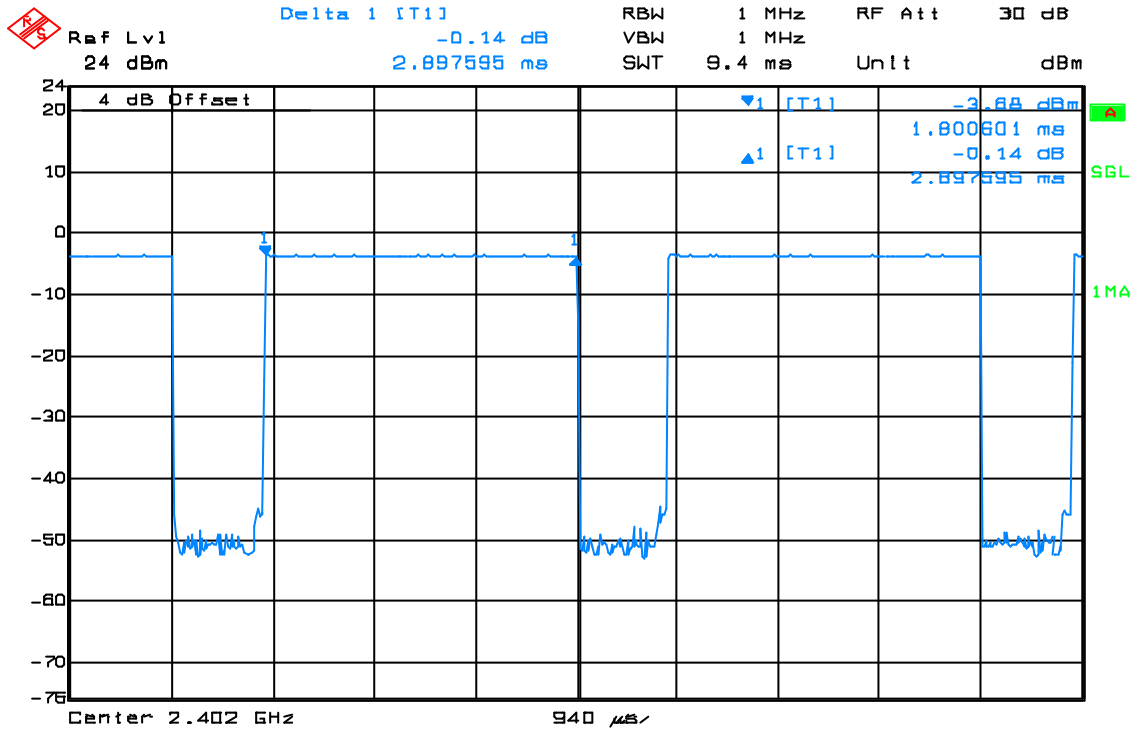

(CH Mid)

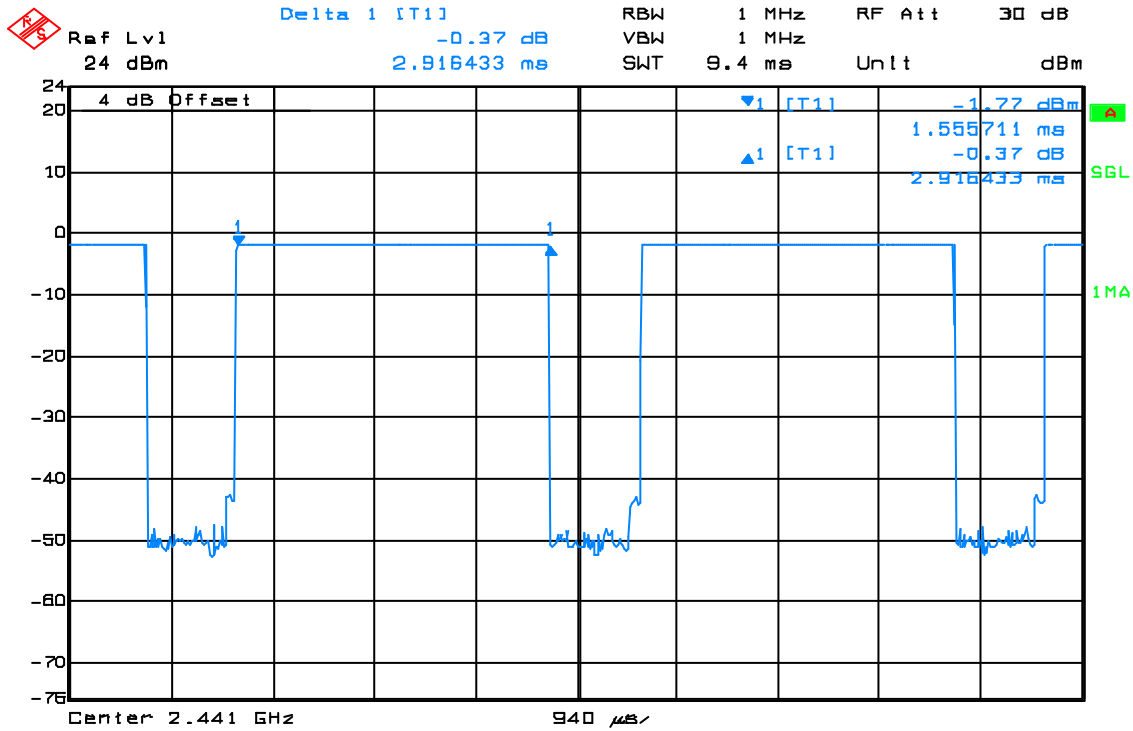



(CH High)

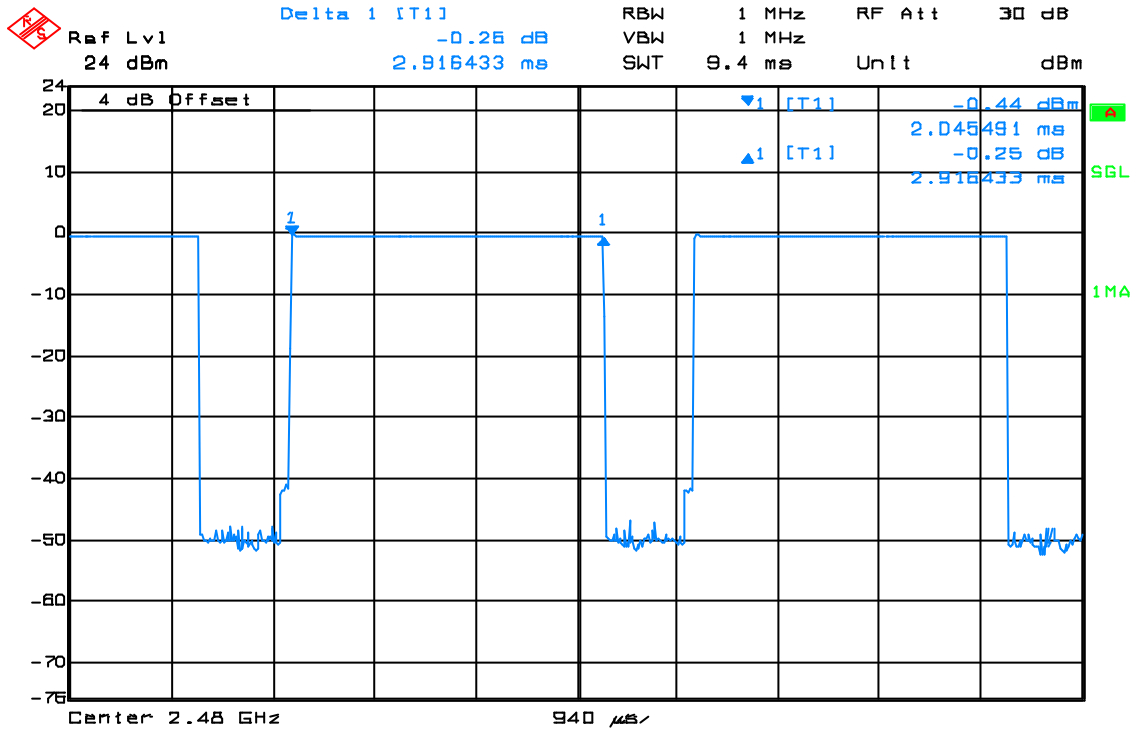

7.6 SPURIOUS EMISSIONS

7.6.1 Conducted Measurement

LIMIT

According to §15.247(d), in any 100 kHz bandwidth outside the frequency bands in which the spread spectrum intentional radiator is operating, the radio frequency power that is produced by the intentional radiator shall be at least 20 dB below that in the 100 kHz bandwidth within the band that contains the highest level of the desired power, based on either an RF conducted or a radiated measurement, provided the transmitter demonstrates compliance with the peak conducted power limits. In addition, radiated emissions which fall in the restricted bands, as defined in §15.205(a), must also comply with the radiated emission limits specified in 15.209(a) (see Section 15.205(c)).

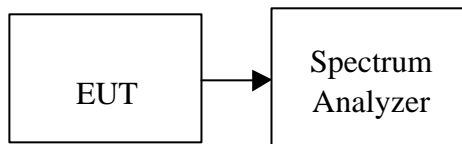

Test Configuration

TEST PROCEDURE

Conducted RF measurements of the transmitter output were made to confirm that the EUT antenna port conducted emissions meet the specified limit and to identify any spurious signals that require further investigation or measurements on the radiated emissions site.

The transmitter output is connected to the spectrum analyzer. The resolution bandwidth is set to 100 kHz. The video bandwidth is set to 100 kHz.

Measurements are made over the 30MHz to 25GHz range with the transmitter set to the lowest, middle, and highest channels.

TEST RESULTS

No non-compliance noted



Test Plot

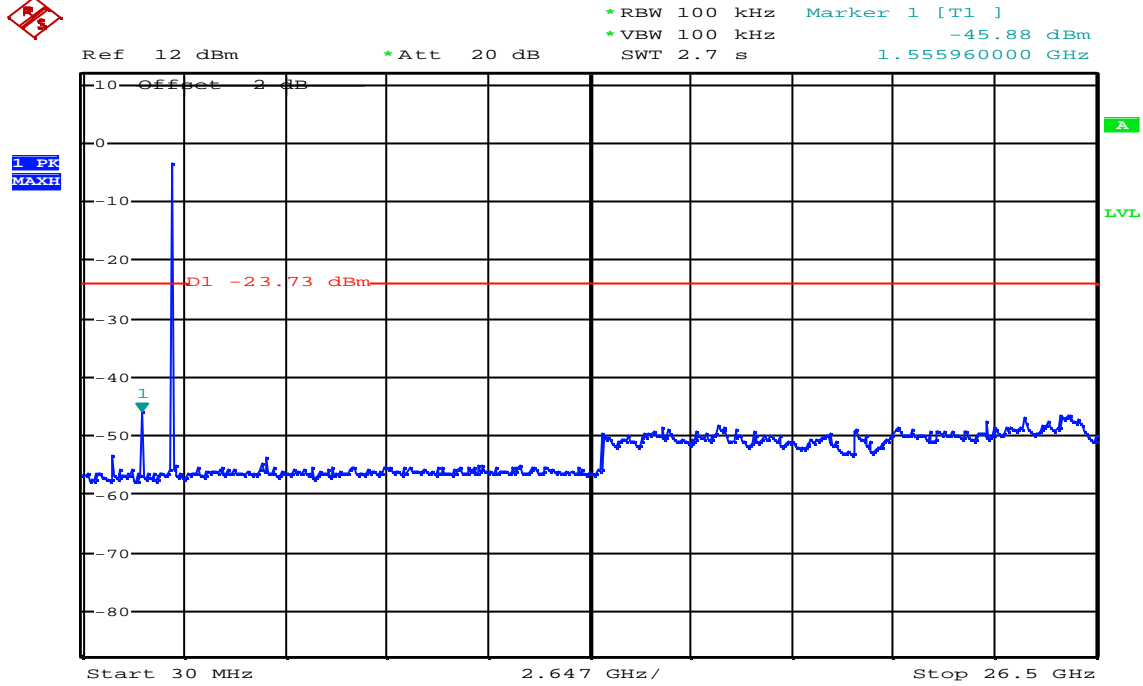

Date: 13.SEP.2007 17:20:03

CH Mid

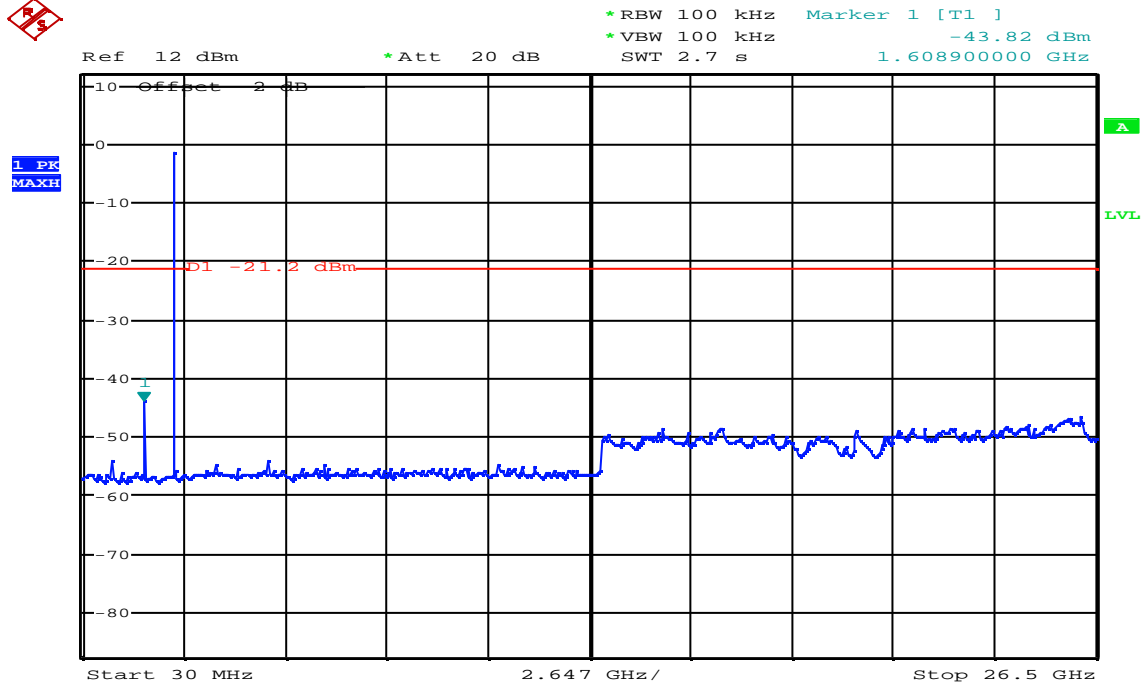

Date: 13.SEP.2007 17:23:16



CH High

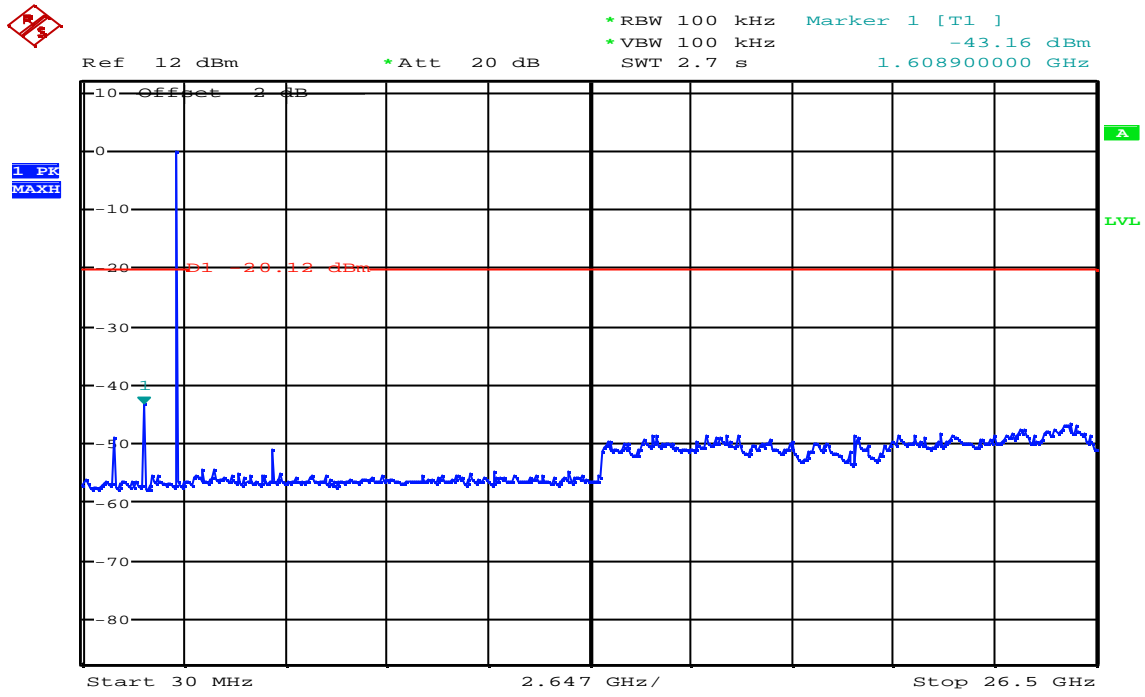

Date: 13.SEP.2007 17:25:40



7.6.2 Radiated Emissions

LIMIT

1. According to §15.209(a), except as provided elsewhere in this Subpart, the emissions from an intentional radiator shall not exceed the field strength levels specified in the following table:

Frequency (MHz)	Field Strength ($\mu\text{V/m}$)	Measurement Distance (m)
30-88	100*	3
88-216	150*	3
216-960	200*	3
Above 960	500	3

Remark: Except as provided in paragraph (g), fundamental emissions from intentional radiators operating under this Section shall not be located in the frequency bands 54-72 MHz, 76-88 MHz, 174-216 MHz or 470-806 MHz. However, operation within these frequency bands is permitted under other sections of this Part, e.g., Sections 15.231 and 15.241.

2. In the emission table above, the tighter limit applies at the band edges.

Frequency (MHz)	Field Strength ($\mu\text{V/m}$ at 3-meter)	Field Strength (dB $\mu\text{V/m}$ at 3-meter)
30-88	100	40
88-216	150	43.5
216-960	200	46
Above 960	500	54

Test Configuration

Below 1 GHz

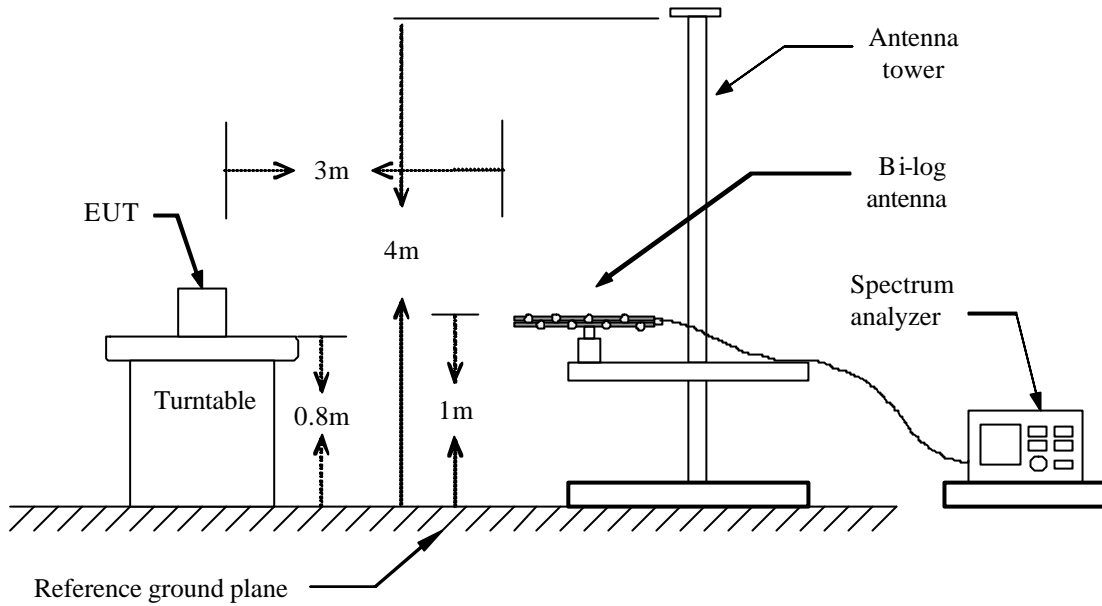

Above 1 GHz

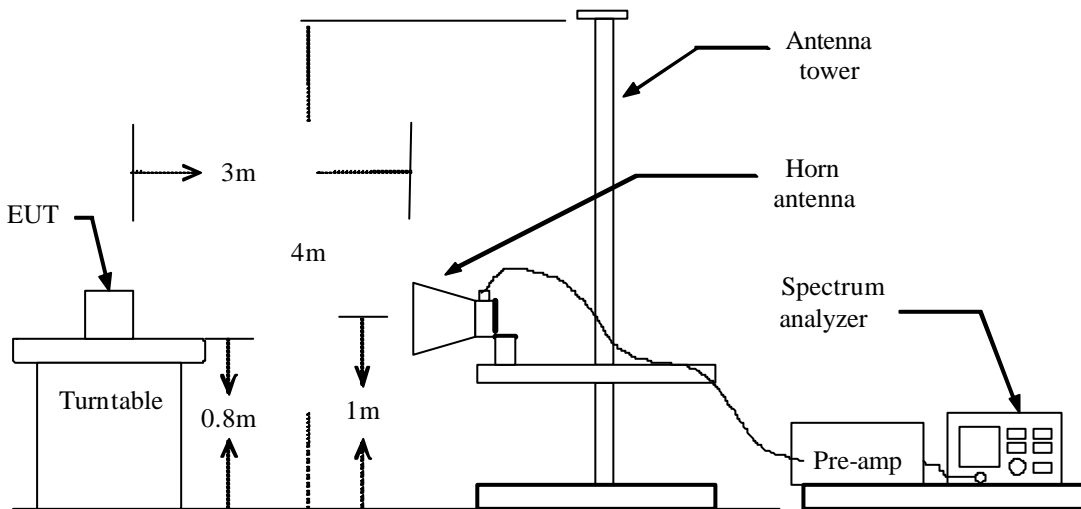



TEST PROCEDURE

1. The EUT is placed on a turntable, which is 0.8m above ground plane.
2. The turntable shall be rotated for 360 degrees to determine the position of maximum emission level.
3. EUT is set 3m away from the receiving antenna, which is varied from 1m to 4m to find out the highest emissions.
4. Maximum procedure was performed on the six highest emissions to ensure EUT compliance.
5. And also, each emission was to be maximized by changing the polarization of receiving antenna both horizontal and vertical.
6. Set the spectrum analyzer in the following setting as:

Below 1GHz:

RBW=100kHz / VBW=300kHz / Sweep=AUTO

Above 1GHz:

(a) PEAK: RBW=VBW=1MHz / Sweep=AUTO

(b) AVERAGE: RBW=1MHz / VBW=10Hz / Sweep=AUTO

7. Repeat above procedures until the measurements for all frequencies are complete.

**TEST RESULTS****Below 1 GHz****Operation Mode:** Normal Link**Test Date:** September 15, 2007**Temperature:** 26°C**Tested by:** ArnoHsieh**Humidity:** 55 % RH**Polarity:** Ver. / Hor.

Freq. (MHz)	Ant.Pol. H/V	Detector Mode (PK/QP)	Reading (dBuV)	Factor (dB)	Actual FS (dBuV/m)	Limit 3m (dBuV/m)	Safe Margin (dB)
59.60	V	Peak	6.14	13.81	19.96	40.00	-20.04
162.70	V	Peak	10.69	10.61	21.30	43.50	-22.20
237.60	V	Peak	12.72	13.80	26.52	46.00	-19.48
440.00	V	Peak	7.78	18.26	26.04	46.00	-19.96
617.00	V	Peak	4.86	21.81	26.68	46.00	-19.32
774.00	V	Peak	4.46	23.28	27.74	46.00	-18.26
57.40	H	Peak	3.92	13.94	17.85	40.00	-22.15
150.90	H	Peak	16.71	10.21	26.91	43.50	-16.59
216.40	H	Peak	13.47	13.03	26.50	46.00	-19.50
368.00	H	Peak	7.79	17.13	24.92	46.00	-21.08
505.00	H	Peak	3.79	19.68	23.47	46.00	-22.53
613.00	H	Peak	4.33	21.77	26.11	46.00	-19.89
750.00	H	Peak	4.10	22.84	26.94	46.00	-19.06

Remark:

1. Measuring frequencies from 30 MHz to the 1GHz.
2. Radiated emissions measured in frequency range from 30 MHz to 1000MHz were made with an instrument using Peak detector mode.
3. Data of measurement within this frequency range shown " --- " in the table above means the reading of emissions are attenuated more than 20dB below the permissible limits or the field strength is too small to be measured.
4. The IF bandwidth of SPA between 30MHz to 1GHz was 100kHz.

**Above 1 GHz****Operation Mode:** TX / CH Low**Test Date:** September 13, 2007**Temperature:** 23°C**Tested by:** Arno Hsien**Humidity:** 55 % RH**Polarity:** Ver. / Hor.

Freq. (MHz)	Ant. Pol H/V	Peak Reading (dBuV)	AV Reading (dBuV)	Ant. / CL CF (dB)	Actual Fs		Peak Limit (dBuV/m)	AV Limit (dBuV/m)	Margin (dB)	Remark
					Peak (dBuV/m)	AV (dBuV/m)				
1060.00	V	47.30	---	-10.42	36.88	---	74.00	54.00	-17.12	Peak
1596.00	V	46.88	---	-7.84	39.04	---	74.00	54.00	-14.96	Peak
2868.00	V	42.69	---	-2.71	39.98	---	74.00	54.00	-14.02	Peak
7550.00	V	32.55	---	7.12	39.67	---	74.00	54.00	-14.33	Peak
N/A										
1384.00	H	44.65	---	-8.93	35.72	---	74.00	54.00	-18.28	Peak
1604.00	H	53.68	---	-7.80	45.88	---	74.00	54.00	-8.12	Peak
2712.00	H	42.82	---	-3.42	39.40	---	74.00	54.00	-14.60	Peak
7550.00	H	33.05	---	7.12	40.17	---	74.00	54.00	-13.83	Peak
N/A										

Remark:

1. Measuring frequencies from 1 GHz to the 10th harmonic of highest fundamental frequency.
2. Measurements above show only up to 6 maximum emissions noted, or would be lesser if no specific emissions from the EUT are recorded (ie: margin > 20dB from the applicable limit) and considered that's already beyond the background noise floor.
3. Radiated emissions measured in frequency above 1000MHz were made with an instrument using Peak detector mode and average detector mode of the emission shown in Actual FS column.
4. Spectrum setting:
 - a. Peak Setting 1GHz to 10th harmonics of fundamental, RBW = 1MHz, VBW = 1MHz, Sweep time = Auto.
 - b. AV Setting 1GHz to 10th harmonics of fundamental, RBW = 1MHz, VBW = 10Hz, Sweep time = Auto.

**Operation Mode:** TX / CH Mid**Test Date:** September 13, 2007**Temperature:** 23°C**Tested by:** Arno Hsien**Humidity:** 55 % RH**Polarity:** Ver. / Hor.

Freq. (MHz)	Ant. Pol H/V	Peak Reading (dBuV)	AV Reading (dBuV)	Ant. / CL CF (dB)	ACTUAL FS		Peak Limit (dBuV/m)	AV Limit (dBuV/m)	Margin (dB)	Remark
					Peak (dBuV/m)	AV (dBuV/m)				
1064.00	V	48.94	---	-10.40	38.53	---	74.00	54.00	-15.47	Peak
1384.00	V	48.47	---	-8.93	39.55	---	74.00	54.00	-14.45	Peak
1632.00		51.52	---	-7.63	43.88	---	74.00	54.00	-10.12	Peak
1828.00		47.68	---	-6.51	41.17	---	74.00	54.00	-12.83	Peak
2956.00		42.31	---	-2.30	40.01	---	74.00	54.00	-13.99	Peak
7570.00		32.96	---	7.12	40.08	---	74.00	54.00	-13.92	Peak
1176.00	H	45.35	---	-9.89	35.46	---	74.00	54.00	-18.54	Peak
1632.00	H	54.88	---	-7.63	47.24	---	74.00	54.00	-6.76	Peak
1832.00	H	49.12	---	-6.49	42.63	---	74.00	54.00	-11.37	Peak
2740.00	H	42.57	---	-3.30	39.27	---	74.00	54.00	-14.73	Peak
7570.00	H	33.64	---	7.12	40.75	---	74.00	54.00	-13.25	Peak
N/A										

Remark:

1. Measuring frequencies from 1 GHz to the 10th harmonic of highest fundamental frequency.
2. Measurements above show only up to 6 maximum emissions noted, or would be lesser if no specific emissions from the EUT are recorded (ie: margin > 20dB from the applicable limit) and considered that's already beyond the background noise floor.
3. Radiated emissions measured in frequency above 1000MHz were made with an instrument using Peak detector mode and average detector mode of the emission shown in Actual FS column.
4. Spectrum setting:
 - a. Peak Setting 1GHz to 10th harmonics of fundamental, RBW = 1MHz, VBW = 1MHz, Sweep time = Auto.
 - b. AV Setting 1GHz to 10th harmonics of fundamental, RBW = 1MHz, VBW = 10Hz, Sweep time = Auto.

**Operation Mode:** TX / CH High**Test Date:** September 13, 2007**Temperature:** 23°C**Tested by:** Arno Hsien**Humidity:** 55 % RH**Polarity:** Ver. / Hor.

Freq. (MHz)	Ant. Pol H/V	Peak Reading (dBuV)	AV Reading (dBuV)	Ant. / CL CF (dB)	Actual Fs		Peak Limit (dBuV/m)	AV Limit (dBuV/m)	Margin (dB)	Remark
					Peak (dBuV/m)	AV (dBuV/m)				
1332.00	V	46.98	---	-9.17	37.81	---	74.00	54.00	-16.19	Peak
1656.00	V	52.89	---	-7.50	45.40	---	74.00	54.00	-8.60	Peak
1828.00	V	50.63	---	-6.51	44.12	---	74.00	54.00	-9.88	Peak
1992.00	V	47.04	---	-5.58	41.47	---	74.00	54.00	-12.53	Peak
2908.00	V	41.97	---	-2.52	39.44	---	74.00	54.00	-14.56	Peak
7540.00	V	33.02	---	7.12	40.14	---	74.00	54.00	-13.86	Peak
1656.00	H	55.11	---	-7.50	47.62	---	74.00	54.00	-6.38	Peak
1828.00	H	44.32	---	-6.51	37.81	---	74.00	54.00	-16.19	Peak
2768.00	H	42.78	---	-3.17	39.62	---	74.00	54.00	-14.38	Peak
7600.00	H	33.94	---	7.11	41.05	---	74.00	54.00	-12.95	Peak
N/A										

Remark:

1. Measuring frequencies from 1 GHz to the 10th harmonic of highest fundamental frequency.
2. Measurements above show only up to 6 maximum emissions noted, or would be lesser if no specific emissions from the EUT are recorded (ie: margin > 20dB from the applicable limit) and considered that's already beyond the background noise floor.
3. Radiated emissions measured in frequency above 1000MHz were made with an instrument using Peak detector mode and average detector mode of the emission shown in Actual FS column.
4. Spectrum setting:
 - a. Peak Setting 1GHz to 10th harmonics of fundamental, RBW = 1MHz, VBW = 1MHz, Sweep time = Auto.
 - b. AV Setting 1GHz to 10th harmonics of fundamental, RBW = 1MHz, VBW = 10Hz, Sweep time = Auto.

**Operation Mode:** RX / CH Mid**Test Date:** September 13, 2007**Temperature:** 23°C**Tested by:** Arno Hsien**Humidity:** 55 % RH**Polarity:** Ver. / Hor.

Freq. (MHz)	Ant. Pol H/V	Peak Reading (dBuV)	AV Reading (dBuV)	Ant. / CL CF (dB)	Actual Fs		Peak Limit (dBuV/m)	AV Limit (dBuV/m)	Margin (dB)	Remark
					Peak (dBuV/m)	AV (dBuV/m)				
1384.00	V	47.76	---	-8.93	38.83	---	74.00	54.00	-15.17	Peak
1584.00	V	47.84	---	-7.91	39.93	---	74.00	54.00	-14.07	Peak
1864.00	V	46.56	---	-6.31	40.25	---	74.00	54.00	-13.75	Peak
2380.00	V	44.39	---	-4.67	39.72	---	74.00	54.00	-14.28	Peak
N/A										
1628.00	H	46.70	---	-7.66	39.04	---	74.00	54.00	-14.96	Peak
1832.00	H	49.22	---	-6.49	42.73	---	74.00	54.00	-11.27	Peak
1996.00	H	46.41	---	-5.55	40.85	---	74.00	54.00	-13.15	Peak
2440.00	H	46.71	---	-4.54	42.18	---	74.00	54.00	-11.82	Peak
N/A										

Remark:

1. Measuring frequencies from 1 GHz to the 10th harmonic of highest fundamental frequency.
2. Measurements above show only up to 6 maximum emissions noted, or would be lesser if no specific emissions from the EUT are recorded (ie: margin > 20dB from the applicable limit) and considered that's already beyond the background noise floor.
3. Radiated emissions measured in frequency above 1000MHz were made with an instrument using Peak detector mode and average detector mode of the emission shown in Actual FS column.
4. Spectrum setting:
 - a. Peak Setting 1GHz to 10th harmonics of fundamental, RBW = 1MHz, VBW = 1MHz, Sweep time = Auto.
 - b. AV Setting 1GHz to 10th harmonics of fundamental, RBW = 1MHz, VBW = 10Hz, Sweep time = Auto.



7.7 POWERLINE CONDUCTED EMISSIONS

LIMIT

According to §15.207(a), except as shown in paragraphs (b) and (c) of this section, for an intentional radiator that is designed to be connected to the public utility (AC) power line, the radio frequency voltage that is conducted back onto the AC power line on any frequency or frequencies within the band 150 kHz to 30 MHz shall not exceed the limits in the following table, as measured using a 50 μ H/50 ohms line impedance stabilization network (LISN). Compliance with the provisions of this paragraph shall be based on the measurement of the radio frequency voltage between each power line and ground at the power terminal. The lower limit applies at the boundary between the frequency ranges.

Frequency Range (MHz)	Limits (dB μ V)	
	Quasi-peak	Average
0.15 to 0.50	66 to 56*	56 to 46*
0.50 to 5	56	46
5 to 30	60	50

* Decreases with the logarithm of the frequency.

Test Configuration

See test photographs attached in Appendix 1 for the actual connections between EUT and support equipment.

TEST PROCEDURE

1. The EUT was placed on a table, which is 0.8m above ground plane.
2. Maximum procedure was performed on the six highest emissions to ensure EUT compliance.
3. Repeat above procedures until all frequency measured were complete.

**TEST RESULTS**

The initial step in collecting conducted data is a spectrum analyzer peak scan of the measurement range. Significant peaks are then marked as shown on the following data page, and these signals are then quasi-peaked.

Operation Mode: Charging **Test Date:** May 3, 2007
Temperature: 22°C **Tested by:** Arno Hsieh
Humidity: 55% RH

Freq. (MHz)	QP Reading	AV Reading	Corr. factor	QP Result	AV Result	QP Limit	AV Limit	QP Margin	AV Margin	Note
0.21	44.21	41.21	0.20	44.41	41.41	63.21	53.21	-18.80	-11.80	L1
0.35	40.71	40.14	0.20	40.91	40.34	58.96	48.96	-18.05	-8.62	L1
0.56	39.57	38.57	0.10	39.67	38.67	56.00	46.00	-16.33	-7.33	L1
0.91	33.14	32.00	0.10	33.24	32.10	56.00	46.00	-22.76	-13.90	L1
7.27	31.40	26.87	0.54	31.94	27.41	60.00	50.00	-28.06	-22.59	L1
20.05	32.74	28.57	1.50	34.24	30.07	60.00	50.00	-25.76	-19.93	L1
30.00	31.91	25.15	1.90	33.81	27.05	60.00	50.00	-26.19	-22.95	L1
0.21	41.51	37.68	0.20	41.71	37.88	63.21	53.21	-21.50	-15.33	L2
0.49	32.60	31.44	0.11	32.71	31.55	56.17	46.17	-23.46	-14.62	L2
1.82	17.46	13.90	0.18	17.64	14.08	56.00	46.00	-38.36	-31.92	L2
7.20	34.21	30.72	0.43	34.64	31.15	60.00	50.00	-25.36	-18.85	L2
8.46	26.58	21.67	0.59	27.17	22.26	60.00	50.00	-32.83	-27.74	L2
20.83	32.63	27.33	1.35	33.98	28.68	60.00	50.00	-26.02	-21.32	L2
30.00	31.85	24.97	0.00	31.85	24.97	60.00	50.00	-28.15	-25.03	L2

Remark:

1. Measuring frequencies from 0.15 MHz to 30MHz.
2. The emissions measured in frequency range from 0.15 MHz to 30MHz were made with an instrument using Quasi-peak detector and average detector.
3. "---" denotes the emission level was or more than 2dB below the Average limit
4. The IF bandwidth of SPA between 0.15MHz to 30MHz was 10kHz; the IF bandwidth of Test Receiver between 0.15MHz to 30MHz was 9kHz;
5. L1 = Line One (Live Line) / L2 = Line Two (Neutral Line)



Test Plots

Conducted emissions (Line 1)

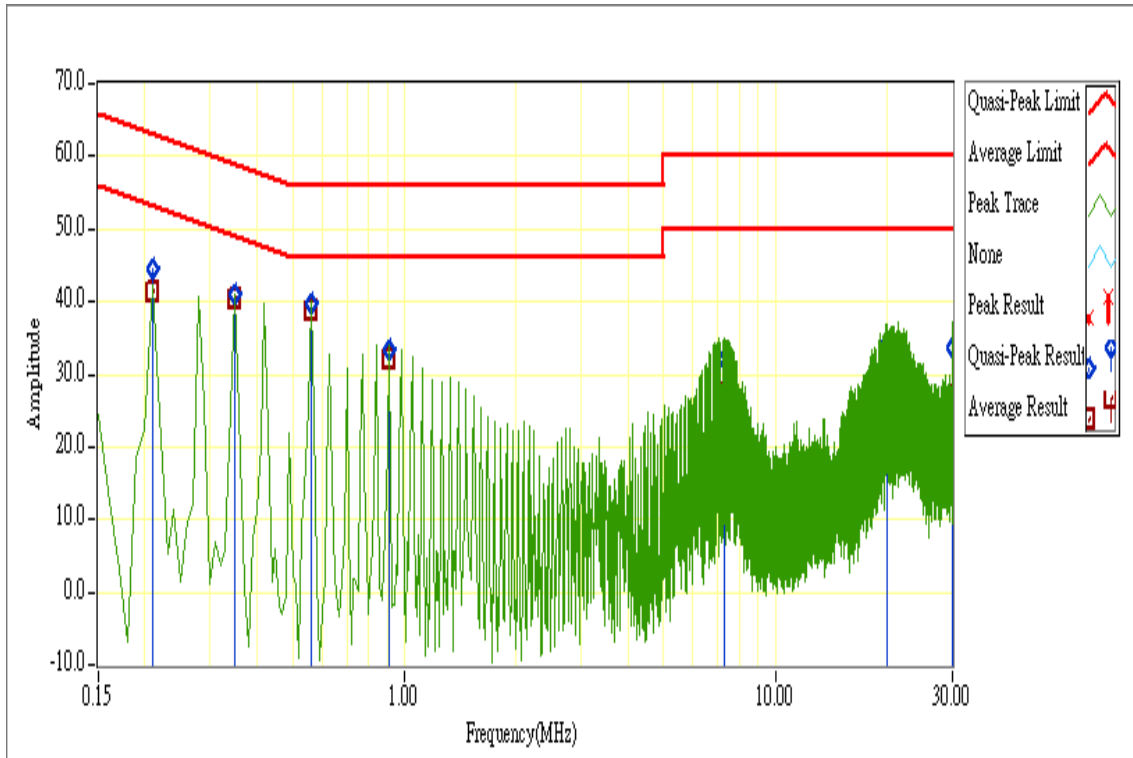

Conducted emissions (Line 2)

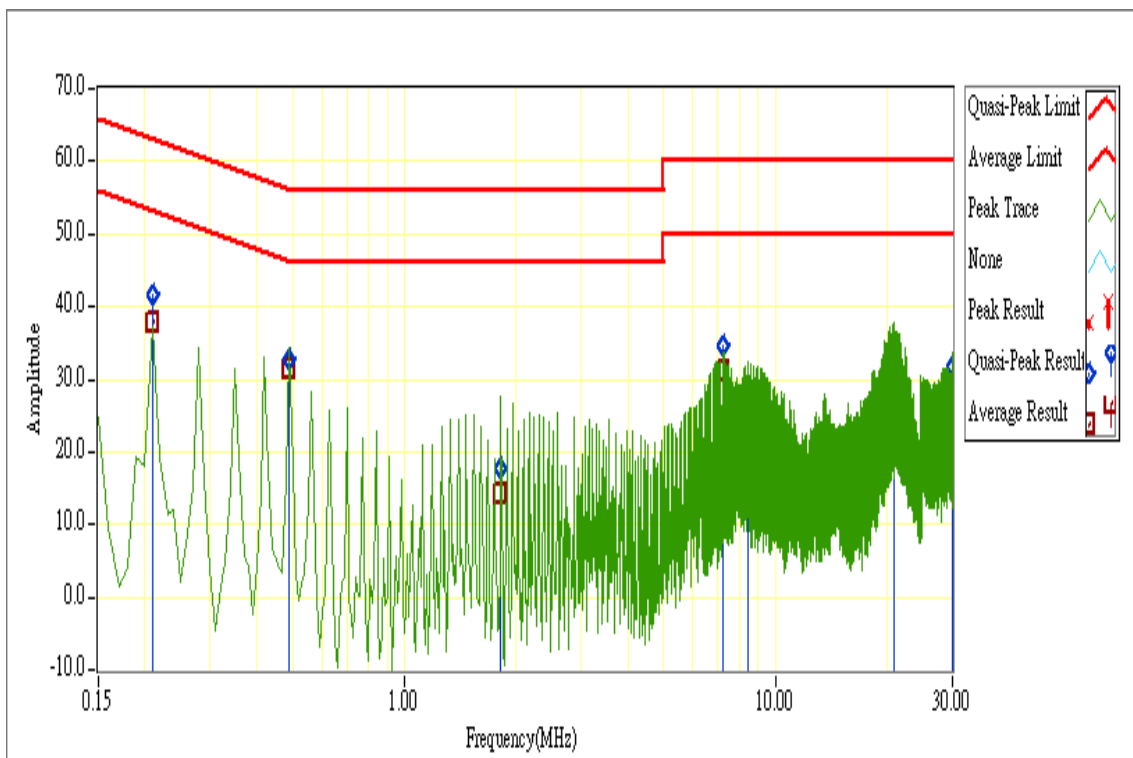



APPENDIX I RADIO FREQUENCY EXPOSURE

LIMIT

According to §15.247(i), systems operating under the provisions of this section shall be operated in a manner that ensures that the public is not exposed to radio frequency energy levels in excess of the Commission's guidelines. See § 1.1307(b)(1) of this chapter.

EUT Specification

EUT	Cradle
Frequency band (Operating)	<input type="checkbox"/> WLAN: 2.412GHz ~ 2.462GHz <input type="checkbox"/> WLAN: 5.18GHz ~ 5.32GHz / 5.50GHz ~ 5.70GHz <input type="checkbox"/> WLAN: 5.745GHz ~ 5.825GHz <input checked="" type="checkbox"/> Others: <u>Bluetooth: 2.402GHz ~ 2.480GHz</u>
Device category	<input type="checkbox"/> Portable (<20cm separation) <input checked="" type="checkbox"/> Mobile (>20cm separation) <input type="checkbox"/> Others _____
Exposure classification	<input type="checkbox"/> Occupational/Controlled exposure ($S = 5mW/cm^2$) <input checked="" type="checkbox"/> General Population/Uncontrolled exposure ($S=1mW/cm^2$)
Antenna diversity	<input checked="" type="checkbox"/> Single antenna <input type="checkbox"/> Multiple antennas <input type="checkbox"/> Tx diversity <input type="checkbox"/> Rx diversity <input type="checkbox"/> Tx/Rx diversity
Max. output power	-0.04 dBm (0.9908 mW)
Antenna gain (Max)	3.0 dBi (Numeric gain: 1.996)
Evaluation applied	<input type="checkbox"/> MPE Evaluation <input type="checkbox"/> SAR Evaluation <input checked="" type="checkbox"/> N/A*
Remark:	
1. The maximum output power is <u>-0.04dBm (0.9908mW) at 2480MHz (with 1.996 numeric antenna gain.)</u> 2. DTS device is not subject to routine RF evaluation; MPE estimate is used to justify the compliance. 3. For mobile or fixed location transmitters, no SAR consideration applied. The maximum power density is 1.0 mW/cm ² even if the calculation indicates that the power density would be larger.	

TEST RESULTS

No non-compliance noted.



MPE evaluation

Calculation

Given $E = \frac{\sqrt{30 \times P \times G}}{d}$ & $S = \frac{E^2}{3770}$

Where $E =$ Field strength in Volts / meter

$P =$ Power in Watts

$G =$ Numeric antenna gain

$d =$ Distance in meters

$S =$ Power density in milliwatts / square centimeter

Combining equations and re-arranging the terms to express the distance as a function of the remaining variables yields:

$$S = \frac{30 \times P \times G}{3770d^2}$$

Changing to units of mW and cm, using:

$$P (mW) = P (W) / 1000 \text{ and}$$

$$d (cm) = d(m) / 100$$

Yields

$$S = \frac{30 \times (P / 1000) \times G}{3770 \times (d / 100)^2} = 0.0796 \times \frac{P \times G}{d^2} \quad \text{Equation 1}$$

Where $d =$ Distance in cm

$P =$ Power in mW

$G =$ Numeric antenna gain

$S =$ Power density in mW / cm²

Maximum Permissible Exposure

EUT output power = 0.9908mW

Numeric Antenna gain = 1.996

Substituting the MPE safe distance using d = 20 cm into Equation 1:

Yields

$$S = 0.000199 \times P \times G$$

Where $P =$ Power in mW

$G =$ Numeric antenna gain

$S =$ Power density in mW / cm²

→ Power density = 0.000393mW / cm²

(For mobile or fixed location transmitters, the maximum power density is 1.0 mW/cm² even if the calculation indicates that the power density would be larger.)