Reference Manual

9500CE

Version 1.03



Copyright Notice

Copyright © 2006 CIPHERLAB CO., LTD.

All rights reserved

The software contains proprietary information of CIPHERLAB CO., LTD.; it is provided under a license agreement containing restrictions on use and disclosure and is also protected by copyright law. Reverse engineering of the software is prohibited.

Due to continued product development this information may change without notice. The information and intellectual property contained herein is confidential between CIPHERLAB and the client and remains the exclusive property of CIPHERLAB CO., LTD. If you find any problems in the documentation, please report them to us in writing. CIPHERLAB does not warrant that this document is error-free.

No part of this publication may be reproduced, stored in a retrieval system, or transmitted in any form or by any means, electronic, mechanical, photocopying, recording or otherwise without the prior written permission of CIPHERLAB CO., LTD.

For product consultancy and technical support, please contact your local sales representative. Also, you may visit our web site for more information.

The CipherLab logo is a registered trademark of CIPHERLAB CO., LTD.

Microsoft, Windows, and the Windows logo are registered trademarks of Microsoft Corporation in the United States and/or other countries.

Bluetooth is a trademark of Bluetooth SIG, Inc., U.S.A.

Other product names mentioned in this manual may be trademarks or registered trademarks of their respective companies and are hereby acknowledged.

The editorial use of these names is for identification as well as to the benefit of the owners, with no intention of infringement.

CIPHERLAB CO., LTD.
Website: <http://www.cipherlab.com>

FCC Regulations

This equipment has been tested and found to comply with the limits for a Class B digital device, pursuant to Part 15 of the FCC Rules. These limits are designed to provide reasonable protection against harmful interference in a residential installation. This equipment generates, uses and can radiate radio frequency energy and, if not installed and used in accordance with the instructions, may cause harmful interference to radio communications. However, there is no guarantee that interference will not occur in a particular installation. If this equipment does cause harmful interference to radio or television reception, which can be determined by turning the equipment off and on, the user is encouraged to try to correct the interference by one or more of the following measures:

- Reorient or relocate the receiving antenna.
- Increase the separation between the equipment and receiver.
- Connect the equipment into an outlet on a circuit different from that to which the receiver is connected.
- Consult the dealer or an experienced radio/TV technician for help.

Important Safety Precautions

- RISK OF EXPLOSION IF BATTERY IS REPLACED BY AN INCORRECT TYPE
- DISPOSE OF USED BATTERIES ACCORDING TO THE INSTRUCTIONS
- The use of any batteries or charging devices, which are not originally sold or manufactured by CipherLab, will void your warranty and may cause damage to human body or the product itself.
- The charging and communication cradle uses an AC power adaptor. A socket outlet shall be installed near the equipment and shall be easily accessible. The power adaptor should comply with L.P.S test. Make sure there is stable power supply for the terminal or its peripherals to operate properly.
- DO NOT disassemble, incinerate or short circuit the battery pack.
- DO NOT expose the terminal or the battery pack to any flammable sources.
- Under no circumstances, internal components are self-serviceable.
- Per FDA and IEC standards, the scan engines described in this manual are not given a laser classification. However, the following precautions should be observed:

CAUTION

This laser component emits FDA/IEC Class 2 laser light at the exit port. Do not stare into beam.

Care & Maintenance

- This terminal is intended for industrial use. The terminal is rated IP 64, however, it may do damage to the terminal when being exposed to extreme temperatures or soaked wet.
- When the body of the terminal gets dirty, use a clean and wet cloth to wipe off the dust. DO NOT use/mix any bleach or cleaner. Always keep the LCD dry.
- For a liquid crystal display (LCD) or touch screen, use a clean, non-abrasive, lint-free cloth to wipe dust off the screen. DO NOT use any pointed or sharp object to move against the surface.
- Battery disposal – For green-environment issue, it is important that batteries should be recycled in a proper way.
- If you want to put away the terminal for a period of time, download the collected data to a host computer, and then take out the battery pack. Store the terminal and battery pack separately.
- When the terminal resumes its work, the main and backup batteries will take a certain time to become fully charged.
- If you shall find the terminal malfunctioning, write down the specific scenario and consult your local sales representative.

Power Management

For any portable device, power management is a critical issue especially when you are on the road. Below are some tips to help you save battery power.

- To speed up charging the terminal, turn off the terminal and seat it in the cradle.
- Bring a second battery pack on the road.
- Stop wireless connectivity, Bluetooth, 802.11b that is not in use.

The power to the wireless modules, 802.11b, is controlled by **PwrMg.exe** (the Wireless Power Manager), which can be found on the taskbar ().

- To save power, go to **Start > Settings > Control Panel** for related settings:



Display

Double-tap the Display icon

1. Tap the Backlight tab.
2. Select one or both of the check boxes to automatically turn off the LCD backlight when using batteries or external power. From the appropriate list, select the amount of time the device should be idle before the backlight is turned off.
3. Then, tap the [Advanced] button to view more backlight options.
4. In the Settings tab, you can dim the LCD backlight when in a well-lit working area for AC and battery powered respectively.



Power

Double-tap the Power icon

1. Tap the Schemes tab.
2. Select the desired power scheme and options for suspending operation when not in use.

Contents

Copyright Notice	II
FCC Regulations	III
Important Safety Precautions	III
Care & Maintenance	IV
Power Management	V
Preface	1
Revision History	錯誤! 尚未定義書籤。
CHAPTER 1 - Introduction	3
1.1 Unpacking the package	3
1.2 Options	3
1.3 Product Highlights	4
1.4 Nomenclature	5
1.4.1 9500CE	5
1.4.2 Accessories & Peripherals	6
1.4.3 Dimensions	7
1.5 Features	8
1.5.1 Battery	8
1.5.2 CPU	11
1.5.3 Memory & Calendar	11
1.5.4 Keypad	13
1.5.5 LCD	16
1.5.6 Status LED	19
1.5.7 Speaker	19
1.5.8 Vibrator	19
1.5.9 Reader	20
1.5.10 Wireless Support	22
1.5.11 Resistance	22

CHAPTER 2 - Installation	23
2.1 Main & Backup Batteries	24
2.2 Hand Strap	26
2.3 Pistol Grip.....	27
2.4 Cradle.....	28
2.4.1 Status Indicators	28
2.4.2 Communication Ports	29
CHAPTER 3 - Windows CE Basics	31
3.1 General.....	32
3.1.1 Device Configuration	33
3.1.2 Turn On/Off.....	34
3.1.3 Desktop Window	34
3.1.4 Input Methods.....	38
3.2 System Reset.....	39
3.2.1 Soft Reset.....	39
3.2.2 Hard Reset	39
3.3 Firmware Update	40
3.4 ActiveSync with a Computer	41
3.5 Quick Launch a Program	42
3.5.1 Add a Program.....	42
3.5.2 Add a Subfolder.....	45
3.5.3 Exit a Program.....	46
3.5.4 Switch between Programs.....	46
3.6 Install a New Program	47
3.6.1 Add/Remove Programs.....	47
3.6.2 Copy & Paste.....	47
3.7 Uninstall a Program	48
3.7.1 ActiveSync: Add/Remove Programs	48
3.7.2 Control Panel > Remove Programs	48
3.8 Backup & Restore Programs.....	50
CHAPTER 4 - Configuration	51
4.1 General Settings.....	51
4.2 Connections	54
4.2.1 USB Connection.....	56
4.2.2 AX88772 (Ethernet)	57
4.2.3 WLAN	58
4.2.4 BTPAN.....	62
CHAPTER 5 - Applications	63
5.1 Wireless Power Manager	64
5.2 Bluetooth Manager	65
5.2.1 Start Bluetooth Services	65
5.2.2 Inquiry	70
5.2.3 Pair.....	71
5.2.4 Connect.....	73
5.2.5 Stop Bluetooth Services.....	77

- 5.3 ReaderConfig.....78
 - 5.3.1 Configure Reader Settings.....79
 - 5.3.2 1D Reader - CCD / Laser.....80
 - 5.3.3 1D Reader - (Extra) Long Range Laser.....89
 - 5.3.4 2D Reader.....96
 - 5.3.5 RFID Reader.....106
- 5.4 Inbox.....107
 - 5.4.1 Create an E-mail Box107
 - 5.4.2 Synchronize Inbox.....110

Specifications 111

APPENDIX I - Comparison of Scan Modes 113

Table of Figures

Figure 1: Nomenclature (front & back)	5
Figure 2: Nomenclature of accessories	6
Figure 3: Dimensions	7
Figure 4: 27-key layout	13
Figure 5: DIP switch for backup battery pack	24
Figure 6: Installing battery pack	25
Figure 7: Installing hand strap	26
Figure 8: Installing pistol grip	27
Figure 9: Cradle LEDs	28

Preface

Delivered in the same form factor of the 9500PPC Series running Windows Mobile 2003SE, the 9500CE Series is the newest member to the Mobile Computer family. As suggested by its model designation, it is designed to run Windows CE 5.0, and therefore, allows more flexibility in customization of applications.

CipherLab has integrated powerful utilities for data collection, processing, and transmission. Its large color transfective TFT display guarantees ease in reading in all lighting conditions. Built-in with Bluetooth and 802.11b technologies, delivers a total wireless solution.

The 9500CE Series is robust in construction to meet industry grade requirements, and has been found durable and resistant to shock, water, and dust. It is specifically designed for all-day, everyday use as well as for data-intensive applications in harsh environments.

This manual serves to guide you through how to install, configure, and operate the terminal. The Care & Maintenance section is specifically prepared for those who are in charge of taking care of the terminal.

We recommend you to keep one copy of the manual at hand for quick reference or maintenance purposes. To avoid any improper disposal or operation, please read the manual thoroughly before use.

Thank you for choosing CipherLab products!

CHAPTER 1

Introduction

This chapter explains the hardware parts and features of the 9500CE terminal.

1.1 Unpacking the package

The following items are included in the package. Save the box and packaging material for future use in case you need to store or ship the terminal.

- 9500CE terminal
- Rechargeable Li-ion battery pack
- Stylus
- Hand strap
- Software CD (this Reference Manual is included)

Note: For battery charging, you will need to purchase a charging cradle separately.

1.2 Options

There are a number of optional accessories to enhance the total performance of the terminal. Refer to related sections for details on installation.

Accessories	Features...
Reader	One scan engine: <ul style="list-style-type: none">◆ 1D - CCD, Laser, Long Range Laser, Extra Long Range Laser◆ 2D And/or the RFID reader
Rechargeable Battery Pack	Rechargeable Li battery for non-stop operation
Pistol Grip, Detachable	Facilitating scanning with one hand
Charging & Communication Cradle	Charging of the terminal and one spare battery at the same time while transmitting/receiving data.

1.3 Product Highlights

- Microsoft Windows CE 5.0 software for operating system
- 520 MHz Intel PXA270 processor
- A color transfective TFT display delivers excellent visibility in all lighting conditions
- 128 MB non-volatile NAND flash memory to store OS and software programs (part of the free space is used as a storage card called DiskOnChip)
- 128 MB SDRAM to store and run programs, as well as store program data
- Ergonomic design, ruggedized yet streamlined, with hand strap for secure hold
- Built tough to survive harsh environments - splash, dust & drop resistant
- Dual mode support - One scan engine (integrated barcode scanner/imager) plus one RFID reader
- Wireless connectivity includes Bluetooth and 802.11b
- Programmable feedback includes speaker and vibrator
- Accessories and peripherals include pistol grip, international AC charging cradle, etc.

1.4 Nomenclature

1.4.1 9500CE

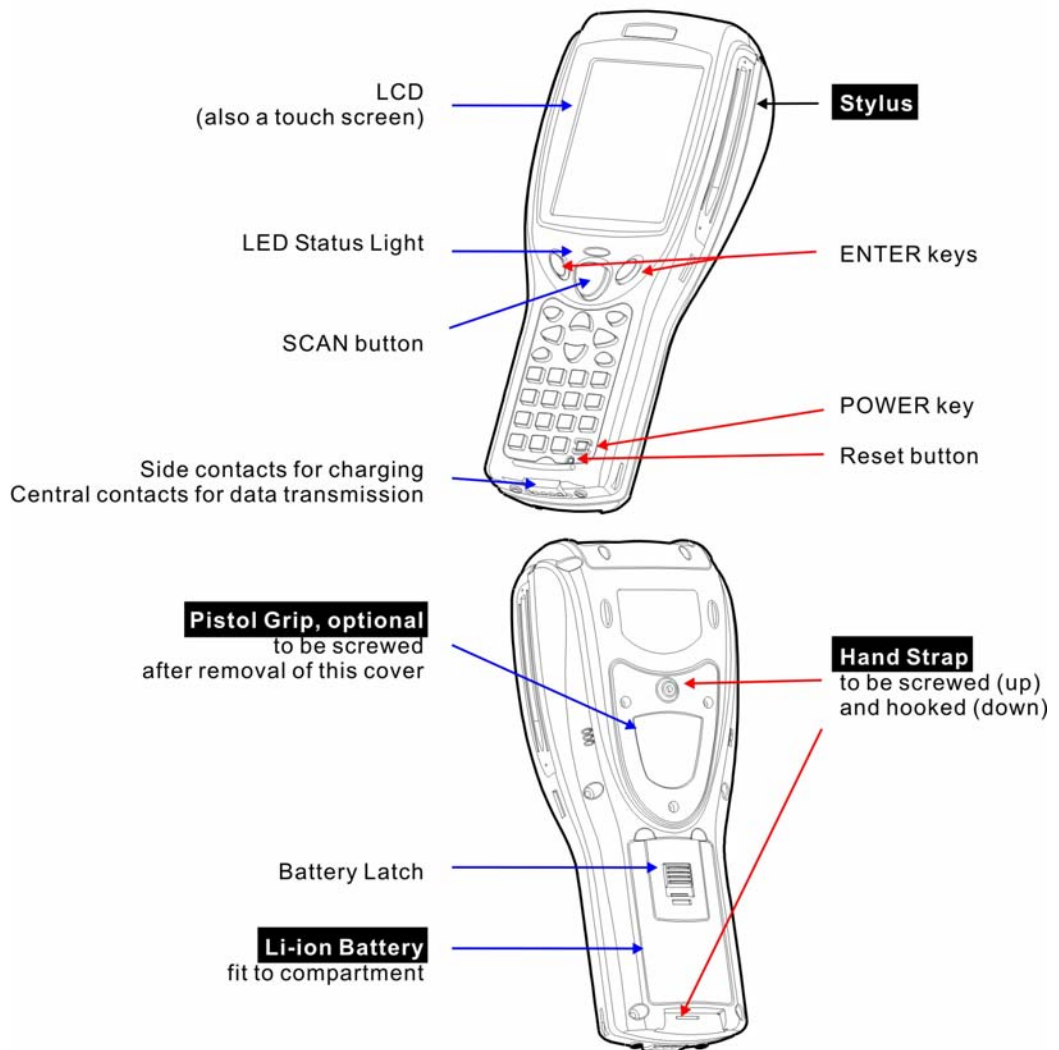

Figure 1: Nomenclature (front & back)

1.4.2 Accessories & Peripherals

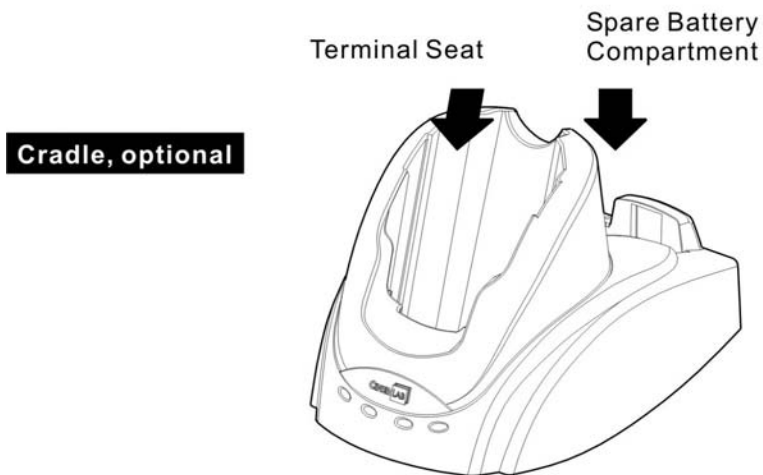
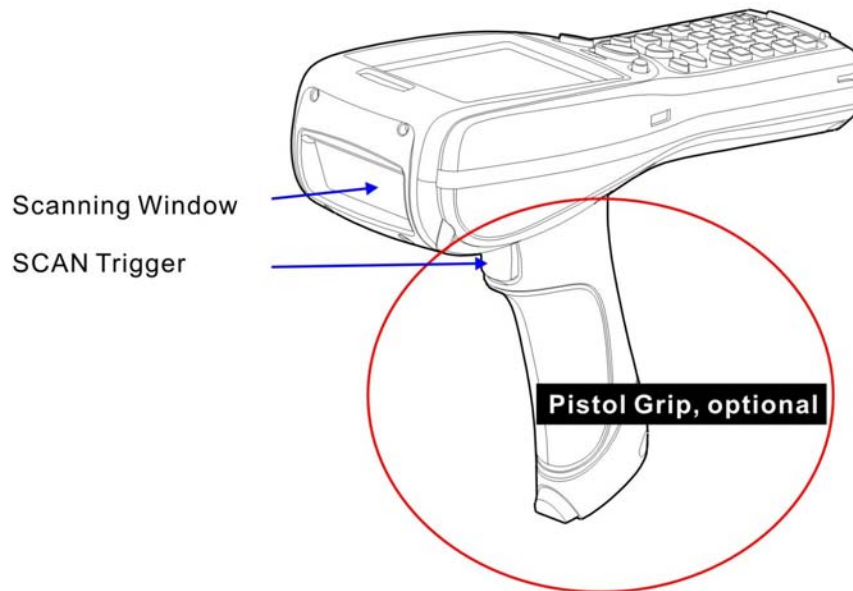

Figure 2: Nomenclature of accessories

1.4.3 Dimensions

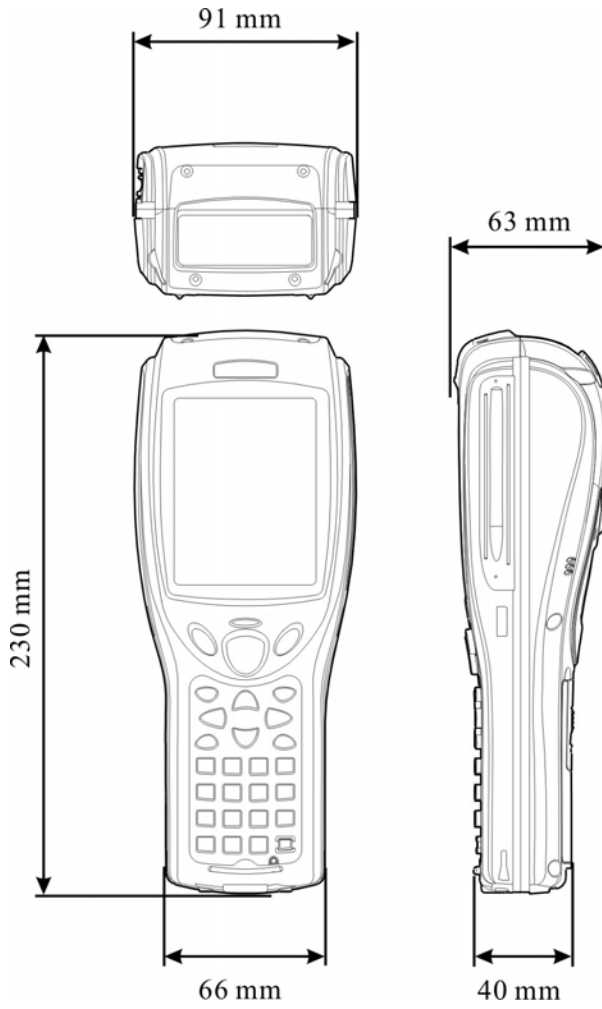

Figure 3: Dimensions

1.5 Features

1.5.1 Battery

Main Battery

- This rechargeable 3.7 V/4000 mAh Li-ion battery pack serves as the main power.
- Normally, it takes approximately four hours to fully charge the battery. The charging time may vary by working condition.
- During normal operation, the terminal can work for up to 16 hours.

Warning: Using backlight, wireless connectivity, and peripherals while on battery power will substantially reduce battery life.

Backup Battery

- The backup battery takes charge when the main battery is removed or drained out.
- If fully charged, it will help retain data in SDRAM and maintain the system running in suspend mode for at least 30 minutes without the main battery. In the meantime, you have to replace the main battery as soon as possible.

Battery Charge

- Initial Charging

The main and backup batteries may not be charged to full for shipment. When you first receive the package, you will need to charge batteries to full before using the terminal.

Note: To charge the batteries for the first time, it requires approximately 8 hours. After the initial charging, it takes only 4 hours to charge the batteries to full.

Because the internal backup battery is constantly charged from the main battery, the initial charging requires installing the battery pack to the terminal and then seating the terminal in the cradle for charging. This will have both the main and backup batteries charged at the same time.





Note: To charge the backup battery, make sure that you slide the DIP switch inside the battery compartment to the ON position.

- Caution of Low Battery Charge

The battery pack is the only power source for the terminal to work. It also charges the backup battery so that the data stored in SDRAM can be retained properly. Therefore, when the main battery charge goes low, replace the battery pack with a charged one or seat it in the cradle for charging as soon as possible. Always save data before it is too late.

Warning: Data loss may occur with SDRAM during low battery condition. Always save data before running out of power or keep a fresh battery for replacement.

- Battery Status Icons

Status Icons	Description
	Main battery is low.
	Main battery is very low.
	Backup battery is low.
	Backup battery is very low.
	Main battery is charging.

Power Properties

The system can be set to three different states to conserve power:

- User Idle state
- System Idle state
- Suspend state



Power

Start > Settings > Control Panel and double-tap the Power icon

1. In the Battery tab, you can always monitor the charging status.
2. Tap the Schemes tab.
3. Select the desired power scheme and options for suspending operation when not in use. The time choices represent the amount of time that must pass before the system will switch to the next power conservation state.

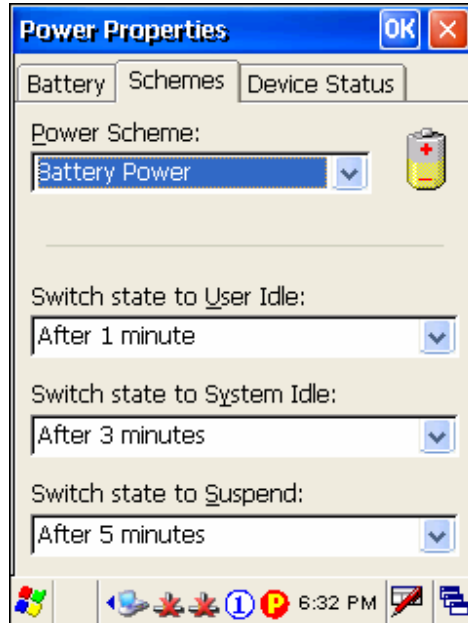
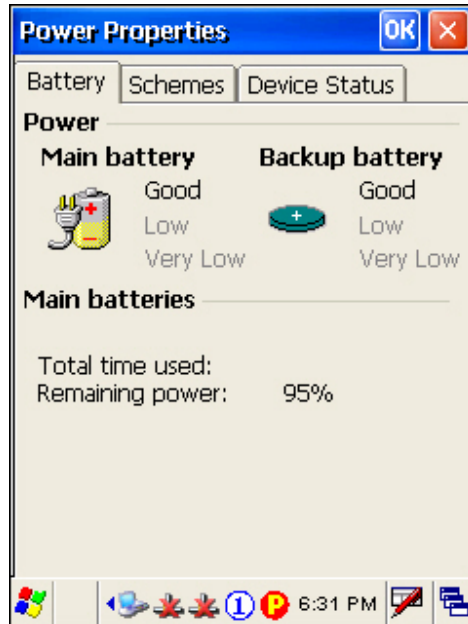

To conserve more power, you may go to **Start > Settings > Control Panel** and double-tap the Display icon to configure the backlight setting.

1.5.2 CPU

Built to run Windows CE 5.0, the 9500CE terminal is equipped with an Intel X-Scale 520 MHz RISC microprocessor.

1.5.3 Memory & Calendar

Read-only Memory (ROM)

- ◆ A total of 128 megabytes flash memory.
- ◆ Mostly, it is for storing OS (Windows CE 5.0) and custom application programs.
- ◆ Yet a small portion of the memory is referred to as DiskOnChip, which can store data and programs that you wish to retain even after a hard reset.

Random-access Memory (RAM)

- ◆ A total of 128 megabytes SDRAM.
- ◆ It is used for storing and running programs, as well as storing program data.
- ◆ Its contents will be retained by the backup battery.

Calendar

- ◆ Equipped with a calendar chip for accurate time/date logging.
- ◆ Non-stop operation is provided through the backup battery.

Caution of Data Loss

When the main battery is removed or drained out, the backup battery is to retain the contents of SDRAM and maintain the OS in suspend mode for at least 30 minutes, on condition that the backup battery has already been fully charged.

If the terminal is to be put away for a couple of days, you should be aware that data loss occurs when both the main and backup batteries discharge completely. It is necessary to backup data and files before putting away the terminal.

System Properties - Memory tab



System

Start > Settings > Control Panel and double-tap the System icon

1. In the Memory tab, it displays the current capacity and usage of the 128 MB onboard SDRAM. (Left below)
2. You may tap, hold, and drag the slider to re-allocate the memory.

SDRAM	Storage memory (left)	Program memory (right)
128 MB onboard	It refers to the memory allocated for file and data storage.	It refers to the memory allocated for running programs.

DiskOnChip Properties

(Desktop) My Device > DiskOnChip

- Tap and hold the DiskOnChip icon and select Properties from the pop-up menu.
- In the Properties tab, it displays the current capacity and usage of DiskOnChip. (Right below)
- The DiskOnChip is part of the onboard 128 MB flash memory. Because the flash memory is non-volatile, data or programs stored in DiskOnChip will not be erased after a hard reset.

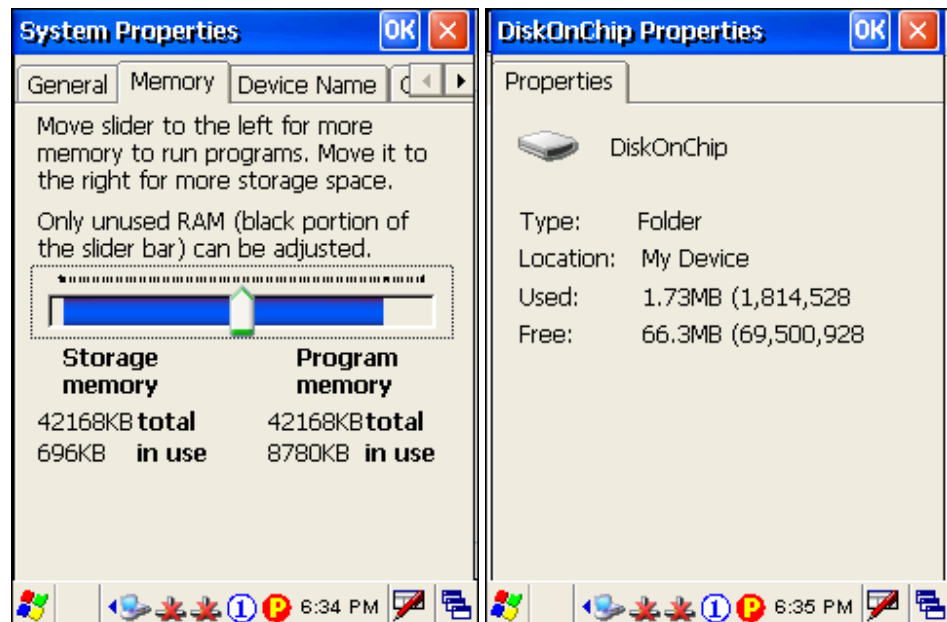

1.5.4 Keypad

The terminal is equipped with a physical keypad that consists of 27 keys. Silicon rubber has been chosen for their durability and prompt feedback.

The layout of the 27-key keypad includes alphanumeric, assorted characters, etc. This keypad is set to numeric mode by default.

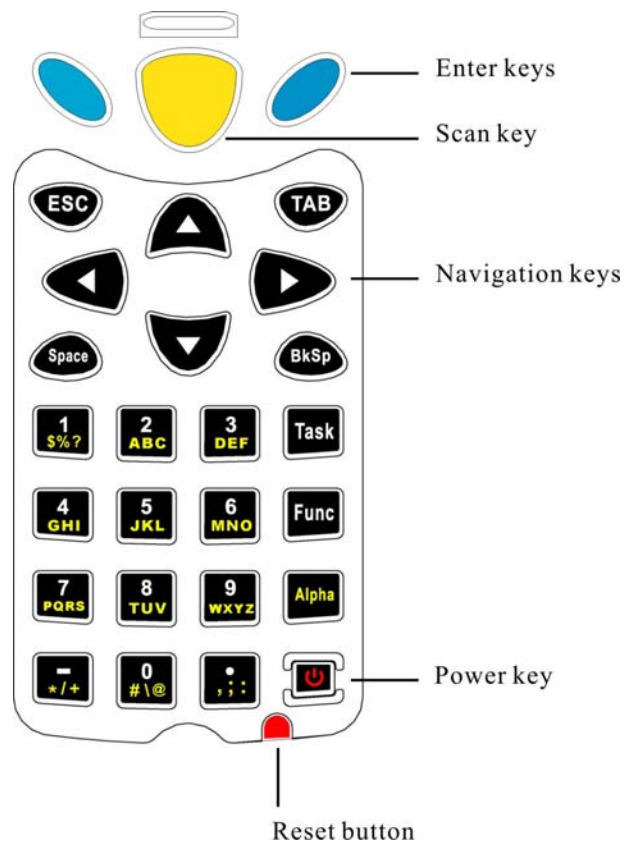
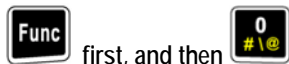

Figure 4: 27-key layout

Note: Functionality of keys is application-dependent.

Keypad Settings



first, and then

- The LED backlight of keypad is turned off by default. It can be toggled ON/OFF by the key combination: [Func] + [0].



Keyboard

Start > Settings > Control Panel and double-tap the Keyboard icon

- The Character Repeat functionality is enabled by default. You may cancel the check box to disable it. When enabled, tap, hold, and drag the slider for a desired Repeat Delay and Repeat Rate.

Warning: Using backlight while on battery power will substantially reduce battery life. It is suggested to turn on the keypad backlight while working in a dark area.

Task Key

The [Task] key on the keypad is set to trigger Windows Explorer.





To launch Windows Explorer, press  on the keypad.

Alpha Key

This alphanumeric keypad is set to numeric mode by default. The Alpha key serves as a toggle among numeric, alpha (lower-case alphabetic), and ALPHA (upper-case alphabetic) modes.

Note: It is not necessary to hold down the [Alpha] key.

The alpha icon will appear on the status bar in a sequence as shown below.

Status Icon	Alpha Key	Input Mode
	N/A	Numbers
	Press  one time	Small letters
	Press  two times	Capital letters

Note: If you are using the software keypad via SIP, tap CAP (Caps Lock) to toggle between upper case and lower case alphabetic modes.

Func Key

The [Func] (function) key serves as a modifier key.

1. To enable this modifier key, press  on the keypad.

A circular icon of the letter "F" will appear on the status bar. This modifier key is hold down as long as the icon is displayed.









2. Now press another key to get the value of key combination (say, press [1] to get the value of F1). The icon will go off now.
3. To get the value of another key combination modified by the [Func] key, repeat the above steps.
4. To abort the key modification, press  again, and the icon will go off.

Note: It is not necessary to hold down the [Func] key.

The functionality of each key combination is application-dependent. Below is a list of the factory setting for a variety of key combinations.

Press  first, and then press one of the following keys for a specific function:

Key Combination	Action
	PgUp (red-coded): move text up one screenful
	PgDn (red-coded): move text down one screenful
	Home (red-coded): move to the beginning of screen or document
	End (red-coded): move to the end of screen or document
	Toggle ON/OFF the backlight of keypad only
	Turn ON the backlight of LCD and decrease its luminosity
	Turn ON the backlight of LCD and increase its luminosity

1.5.5 LCD

The terminal comes with a 3.5" TFT graphic LCD, 240 by 320 pixels resolutions. The LED backlight of screen, which helps ease reading under dim environments, can be controlled manually and automatically.

Warning: Using backlight while on battery power will substantially reduce battery life. It is suggested to dim the backlight while working in a well-lit area or automatically turn off the terminal when not in use.

LCD Settings

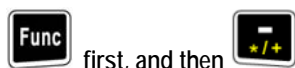

first, and then

- ◆ The LED backlight of the screen can be turned on and adjusted decreasingly by the key combination: [Func] + [—].
- ◆ It is not necessary to hold down the [Func] key; keep pressing the [—] key until the luminosity is decreased to a desired level.

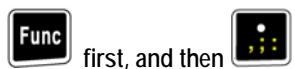

first, and then

- ◆ The LED backlight of the screen can be turned on and adjusted increasingly by the key combination: [Func] + [•].
- ◆ It is not necessary to hold down the [Func] key; keep pressing the [•] key until the luminosity is increased to a desired level.

Display Properties



Display

Start > Settings > Control Panel and double-tap the Display icon

1. Tap the Backlight tab. (Left below)
2. Select one or both of the check boxes to automatically turn off the LCD backlight when using batteries or external power. From the appropriate list, select the amount of time the device should be idle before the backlight is turned off.
3. Then, tap the [Advanced] button. (Right below)
4. In the Settings tab, you can select the luminosity of backlight when it is set to be automatically turned on by pressing any key or tapping the screen. Tap, hold, and drag the slider for AC and battery powered respectively. For more luminosity, move the slider to the right.

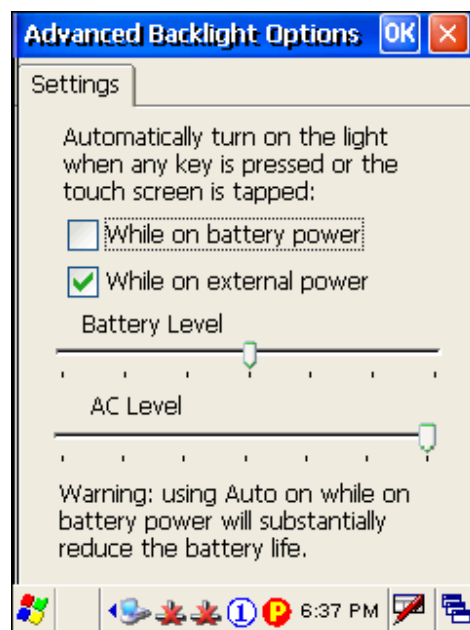
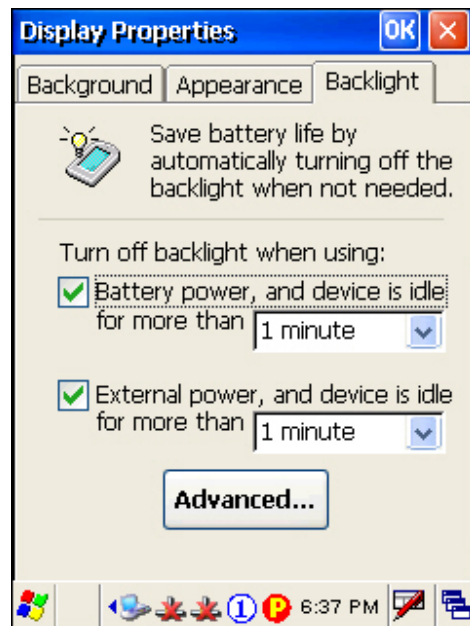

Power

To conserve more power, you may go to **Start > Settings > Control Panel** and double-tap the Power icon to configure the power-saving setting.

Stylus Properties

This LCD is also a touch screen that can be calibrated through screen alignment.

Warning: DO NOT use any pointed or sharp objects to move against the surface of the screen.



Stylus

Start > Settings > Control Panel and double-tap the Stylus icon

1. Tap the Calibration tab.
2. Tap the [Recalibrate] button.



1.5.6 Status LED

The tri-color LED on top of the [Scan] button is used to provide information on status of battery charging or Bluetooth connection.

Tasks	Green LED	Red LED	Green & Red	Blue
Low battery	---	Flashing	---	---
Terminal charging	---	On	---	---
Charging done	On	---	---	---
Charging error	---	---	Flashing	---
Bluetooth connection enabled	---	---	---	On

1.5.7 Speaker

The speaker, a low power transducer type, can be used for playing sounds applied to events in Windows and programs, as well as playing audio files such as .WAV files. In addition, it can be programmed for status feedback.

1.5.8 Vibrator

The terminal is integrated with a vibrator, which is software programmable for feedback. This can be helpful when working in noisy environments.

1.5.9 Reader

A wide variety of scan engines is available for delivering flexibility to meet different requirements.

Types of Reader	Scan Engine										
1D Barcode Reader	<ul style="list-style-type: none"> ◆ CCD (Long Range Imager) ◆ Laser scan engine ◆ Long Range Laser scan engine ◆ Extra Long Range Laser scan engine (with aiming beam) 										
2D Barcode Reader	2D scan engine										
RFID	Tags supported include: <table border="1" style="width: 100%; border-collapse: collapse;"> <thead> <tr> <th style="width: 50%;">Standard</th> <th style="width: 50%;">Labels</th> </tr> </thead> <tbody> <tr> <td>ISO 14443A</td> <td> <ul style="list-style-type: none"> ◆ Mifare Standard 1K ◆ Mifare Standard 4K ◆ Mifare Ultralight ◆ Mifare DESFire ◆ Mifare S50 ◆ SLE44R35 ◆ SLE66R35 </td> </tr> <tr> <td>ISO 14443B</td> <td> <ul style="list-style-type: none"> ◆ SRIX 4K </td> </tr> <tr> <td>ISO 15693</td> <td> <ul style="list-style-type: none"> ◆ ICODE SLI ◆ SRF55V02P ◆ SRF55V02S ◆ SRF55V10P ◆ TI Tag-it HF-I </td> </tr> <tr> <td>ICODE® (Phillips)</td> <td> <ul style="list-style-type: none"> ◆ ICODE </td> </tr> </tbody> </table>	Standard	Labels	ISO 14443A	<ul style="list-style-type: none"> ◆ Mifare Standard 1K ◆ Mifare Standard 4K ◆ Mifare Ultralight ◆ Mifare DESFire ◆ Mifare S50 ◆ SLE44R35 ◆ SLE66R35 	ISO 14443B	<ul style="list-style-type: none"> ◆ SRIX 4K 	ISO 15693	<ul style="list-style-type: none"> ◆ ICODE SLI ◆ SRF55V02P ◆ SRF55V02S ◆ SRF55V10P ◆ TI Tag-it HF-I 	ICODE® (Phillips)	<ul style="list-style-type: none"> ◆ ICODE
Standard	Labels										
ISO 14443A	<ul style="list-style-type: none"> ◆ Mifare Standard 1K ◆ Mifare Standard 4K ◆ Mifare Ultralight ◆ Mifare DESFire ◆ Mifare S50 ◆ SLE44R35 ◆ SLE66R35 										
ISO 14443B	<ul style="list-style-type: none"> ◆ SRIX 4K 										
ISO 15693	<ul style="list-style-type: none"> ◆ ICODE SLI ◆ SRF55V02P ◆ SRF55V02S ◆ SRF55V10P ◆ TI Tag-it HF-I 										
ICODE® (Phillips)	<ul style="list-style-type: none"> ◆ ICODE 										

Dual Mode Support

The terminal allows the co-existence of one integrated scan engine and the RFID reader.

Symbologies Enabled

Depending on the scan engine integrated (check the “Active Device” setting in [ReaderConfig](#)), the terminal is capable of scanning barcodes of a number of symbologies as shown below. If you need to scan barcodes that are encoded in a different symbology, use the ReaderConfig tool to enable the symbology first.

Active Device	Symbologies Enabled
1D Reader	<p>The scan engine can be CCD or Laser.</p> <ul style="list-style-type: none"> ◆ Code 39 ◆ Industrial 25 ◆ Interleaved 25 ◆ Codabar ◆ UPC / EAN ◆ Code 93 ◆ Code 128
1D Long Range Laser	<p>The scan engine can be Long Range Laser or Extra Long Range Laser.</p> <ul style="list-style-type: none"> ◆ Code 39 ◆ Interleaved 25 ◆ UPC / EAN ◆ Code 128 ◆ RSS-14
2D Reader	<p>The scan engine can read linear and 2D barcodes.</p> <ul style="list-style-type: none"> ◆ Code 39 ◆ Interleaved 25 ◆ UPC / EAN ◆ Code 128 ◆ RSS-14 ◆ Postal Codes ◆ PDF417 ◆ Data Matrix ◆ MaxiCode ◆ QR Code

1.5.10 Wireless Support

The 9500CE terminal supports state-of-the-art wireless technologies, Bluetooth and 802.11b, so that it is able to send/receive data in real time in an efficient way.

1.5.11 Resistance

Shock

The terminal is designed for harsh industrial environments, and is proved to survive drop test by the following criteria:

- Surface type: concrete
- Distance to surface: 1.5 meters
- Drop times: multiple

Splash & Dust

The terminal is sealed against moisture and dust to industry standard IP 64.

- 6 = Totally protected against dust
- 4 = Protection against water sprayed from all directions. That is, limited ingress is permitted.

Warning: If additional memory card or peripheral is not factory-installed, the Ingress Protection rating of enclosures may not be the same as claimed.

CHAPTER 2

Installation

The terminal is designed for portable use, and it almost requires no installation except installing the battery pack and necessary auxiliary parts.

Here are some tips and suggestions that ensure safe and comfortable experience with the terminal.

Warning: Read [Important Safety Precautions](#) before installation.

- **Battery Pack**
 - Prepare at least one spare battery pack, especially when on the road.
 - Be cautious of low battery conditions.
 - Turn off the backlight in a bright work area to save battery power.
 - Always use proprietary CipherLab batteries for safety concern.

- **Hand Strap**
 - The hand strap is ideal for one-handed operation, which requires safe and convenient hold of the portable terminal.
 - Always make sure the hand strap is well hooked and screwed to the back of the terminal.

- **Pistol Grip**
 - This contoured pistol grip enables intuitive trigger-and-scan operation, which is very helpful in scan intensive applications.

- **Cradle**
 - Capable of charging and communications at the same time.
 - One terminal seat for terminal with battery pack installed.
 - One spare battery compartment for a spare battery pack.

- **Communications**
 - Wired, making use of ActiveSync via the USB cradle or directly connecting to Ethernet networks.
 - Wireless, making use of wireless technologies, embedded Bluetooth or 802.11b.

2.1 Main & Backup Batteries

When you first receive the package, the rechargeable functionality of the backup battery is turned off. It is controlled by a DIP switch inside the battery compartment as shown below.

For shipping and storage purposes, save the terminal and the main battery in separate packages, and slide the DIP switch to the OFF position (to your right). This will keep both batteries in good condition for future use.

Note: Any improper handling may reduce the battery life.

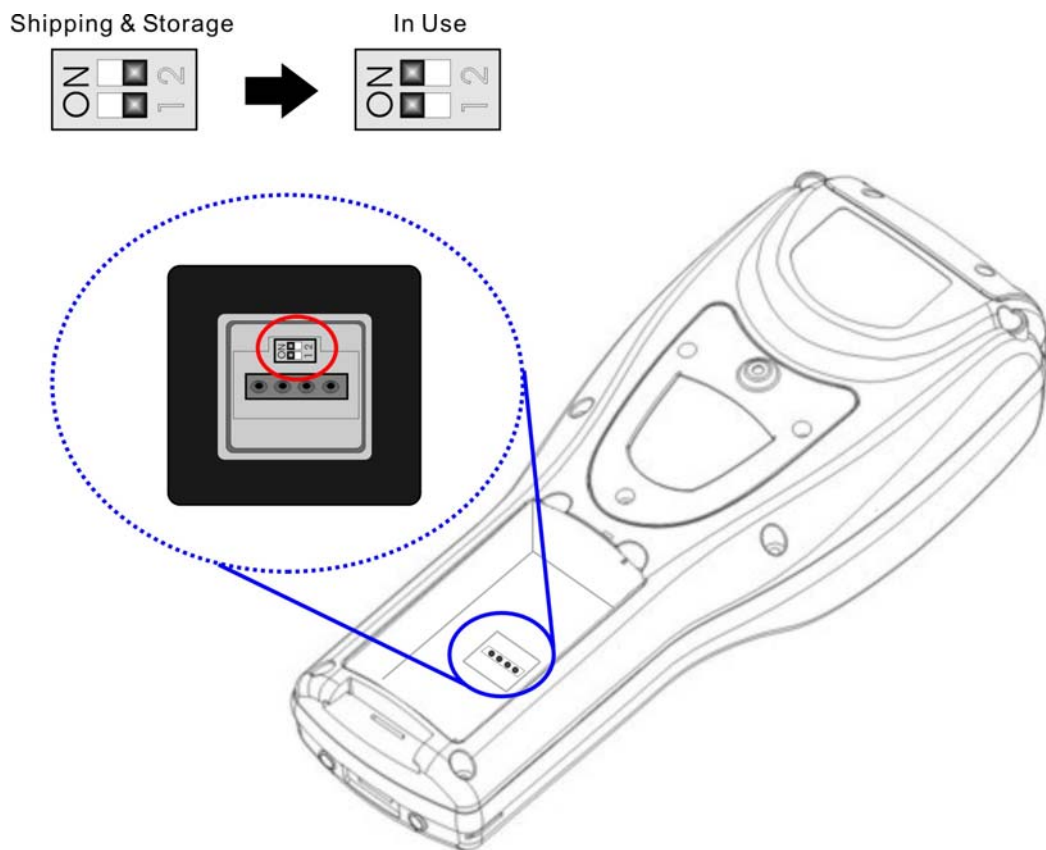

Figure 5: DIP switch for backup battery pack

1. Use the stylus (or a sharp-pointed object, such as a pencil) to slide the DIP switch to the ON position (to your left). Now the internal backup battery can be charged by the main battery.

2. Slide the battery pack into the battery compartment at a proper angle ($30^{\circ}\sim 45^{\circ}$) so that the tabs on the bottom of the battery are hooked in the grooves of the compartment. Make sure that the battery is snugly fit into the compartment.
3. Hold the terminal still and slide the battery latch to lock the battery in the compartment.

Note: For a new battery, make sure it is fully charged before use.

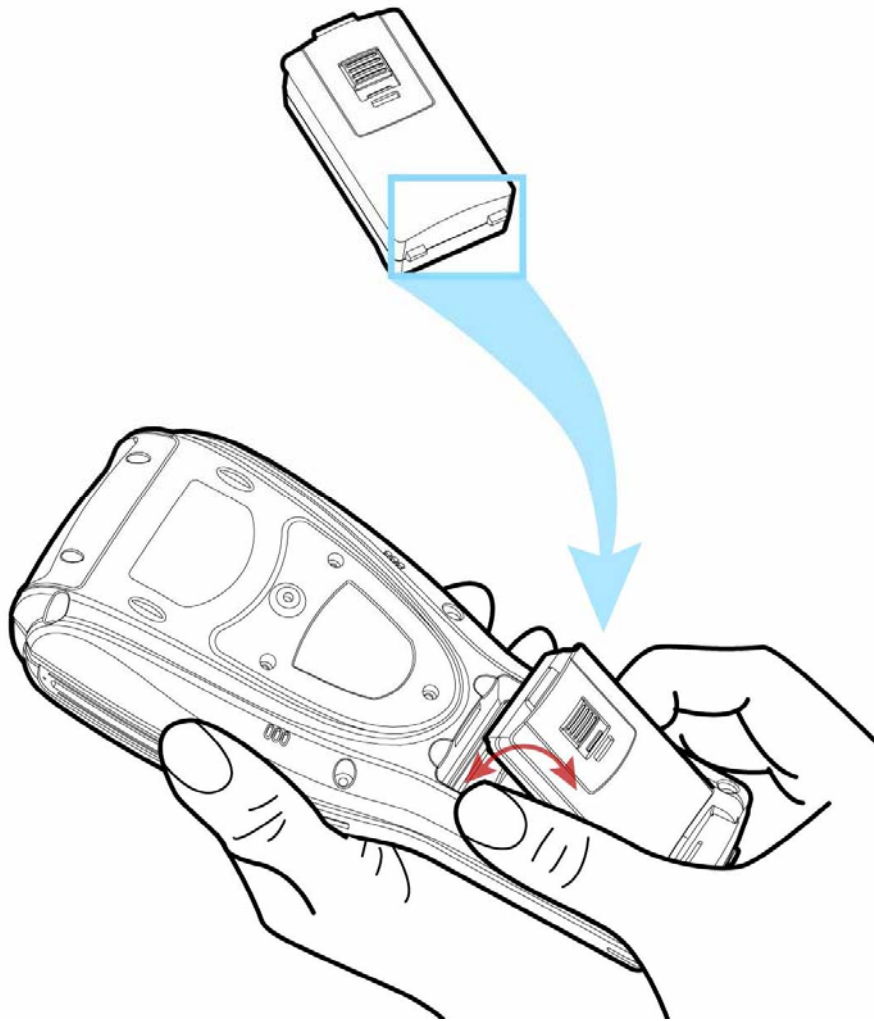

Figure 6: Installing battery pack

2.2 Hand Strap

When a hand strap is necessary, install it to the terminal by following the steps:

1. Place the terminal face down on a flat and clean surface.
2. Screw one end of the hand strap to the shield-like cover on the back of the terminal.
3. Insert and hook the other end of the hand strap to the bottom of the terminal.
4. Make sure the hand strap is securely attached to the terminal.
5. Adjust the length of the hand strap to suit your handbreadth.

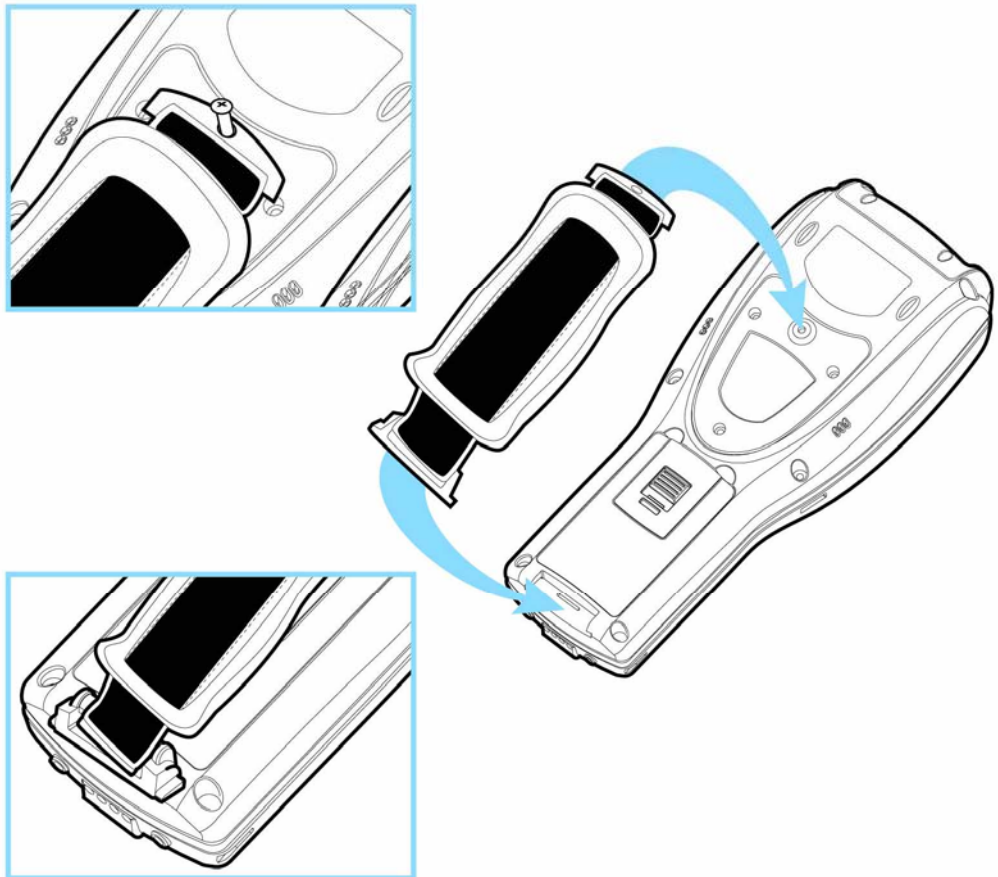

Figure 7: Installing hand strap

2.3 Pistol Grip

When a pistol grip is necessary, install it to the terminal by following the steps:

1. Place the terminal face down on a flat and clean surface.
2. Remove the shield-like cover on the back of the terminal by unscrewing.
If there is a hand strap installed, remove it first. Keep the cover and screws for future use when the pistol grip is not desired.
3. Connect the power connector from the pistol grip to the receptacle on the terminal.
4. Screw the pistol grip to the shield-like cover.
5. Make sure all screws are tightened up but not over-tightened to damage the threads.
6. Turn on the terminal and test the trigger.

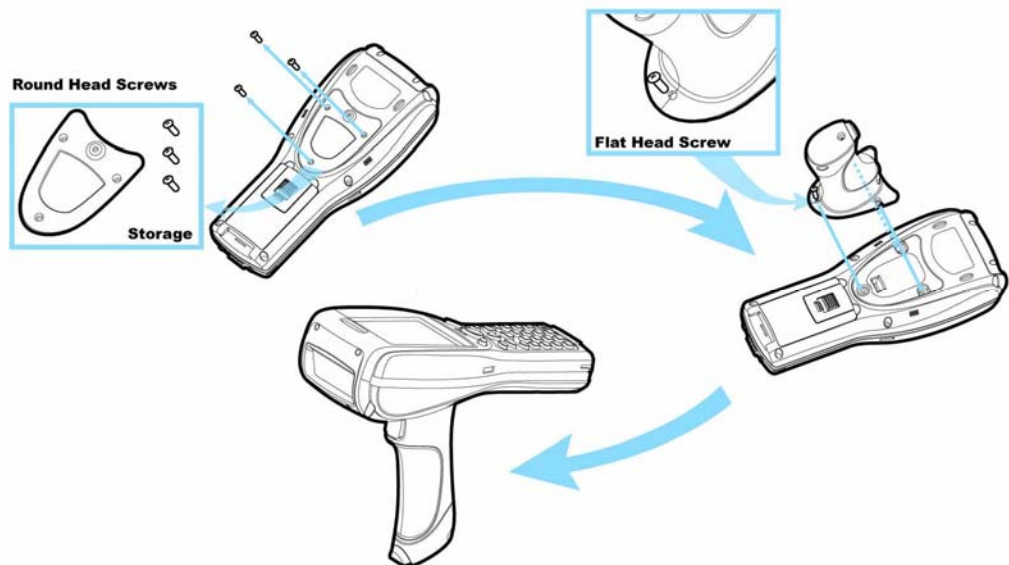



Figure 8: Installing pistol grip

2.4 Cradle

The cradle is designed for charging and communications at the same time.

1. Place the cradle on a flat and clean surface.
2. Connect the line of the power adaptor to the power jack on the back of the cradle.
3. Connect the power adaptor to a suitable power outlet.
4. The cradle is ready for charging the terminal (loaded with main battery) and one spare battery pack.

Seat the terminal and/or the spare battery pack then.

5. If data communications are desired at the same time, a USB connection must be established as well. Make sure that you have Microsoft ActiveSync installed on your computer before you connect the USB cable from the cradle's USB Client port () to your computer. Refer to [ActiveSync with a Computer](#).

2.4.1 Status Indicators

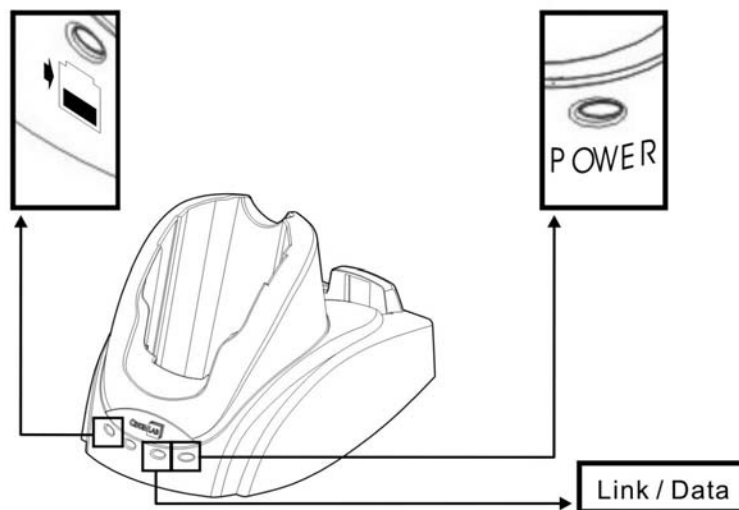

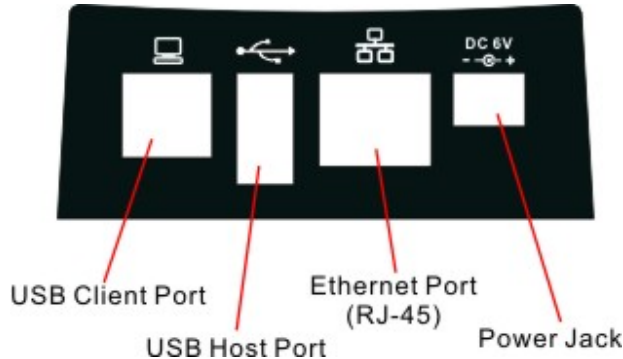

Figure 9: Cradle LEDs

Front Panel LEDs	Tasks	Indication of connection status	
 :	Spare battery charging status	Solid red	Charging
		Solid green	Charging done
		Flashing (red/green)	Error occurs
		Off	Battery not ready
Link / Data:	Network status over Ethernet	Solid green	Ethernet connected
		Flashing	Transmitting / Receiving data
POWER:	Cradle power	Solid green	Power on
		Off	Power off

Warning: Charging error may occur due to a power failure or defected battery contacts.

2.4.2 Communication Ports



Ports (from left to right)	Purpose
USB Client port	This port is provided for connecting to your computer for the use of ActiveSync application.
USB Host port	This port is provided for connecting a USB device: <ul style="list-style-type: none"> ◆ Keyboard ◆ Mouse ◆ Card reader ◆ Storage device, such as a memory stick
Ethernet port	This port is provided for connecting to a legacy network. When connected, the third LED (next to POWER) will become solid green. During data transmission, the LED will be flashing.



CHAPTER 3

Windows CE Basics

This chapter mainly describes the basic skills to work with the 9500CE terminal. The add-on utilities for applications regarding data collection, processing, and transmission, are introduced in the following chapters.

The 9500CE terminal is specifically designed for real-time data collection in the Windows CE 5.0 environment. It won't take long for any Windows user to get familiarized with it. Keep these two basic skills in mind and explore this Windows CE device at ease.

- Double-tap an item to select it.
- Tap and hold an item to see a menu that enables tasks, such as cut, copy, rename, delete, etc.
- Tap and drag to select multiple items.

To close an active window, a dialog box, or a running application, tap  or  when it is available on the toolbar. If the Close button is not displayed, press [ESC] on the physical keypad to exit.

To save current settings and exit, tap  when it is available on the toolbar.

3.1 General

When the 9500CE terminal is fully charged, you may remove it from the cradle. Then turn on the terminal and wait for the Windows CE desktop to come up.

If you are using the terminal for the first time, there are a couple of things to do after the desktop comes up.



- To select your time zone and set the local time: **Start > Settings > Control Panel**, and double-tap the Date/Time icon.



- To align the touch screen: **Start > Settings > Control Panel**, and double-tap the Stylus icon.



- To obtain essential system information, go to **Start > Settings > Control Panel**, and double-tap the System icon. Select the Device Name tab to change the identification for the terminal.

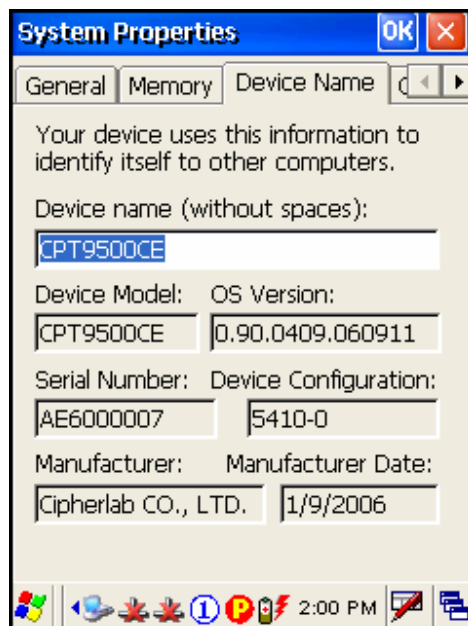

3.1.1 Device Configuration

The device configuration of 9500CE is displayed in 5 digits: xxxx-x

Take the screenshot of System Properties above for example. Its device configuration is “5410-0”, which means the 27-key terminal has equipped with the following parts:

- A scan engine that employs extra long range laser
- An integrated Bluetooth module and an optional Wi-Fi module
- An RFID reader

Device Code	Modular Component	Types
1st digit	Reader module	0= none 1= CCD scan engine 2= Laser scan engine 3= 2D scan engine 4= Long Range Laser scan engine 5= Extra Long Range Laser scan engine
2nd digit	Wireless module	4= Bluetooth + 802.11b 5= Bluetooth only
3rd digit	RFID module	0= none 1= RFID reader
4th digit	Reserved	---
5th digit	Keypad module	0= 27-key

3.1.2 Turn On/Off

Like your PDA, Pocket PC and most handheld devices, the 9500CE terminal functions when it is turned on. This is because the Windows CE operating system eliminates the booting process and runs continuously.

Turn On (= Resume from Suspend)

To turn on the terminal, simply press the [Power] key.

Turn Off (= Suspend)

To turn off the terminal, press the [Power] key again, or select **Suspend** from the Start Menu.

The system is now ready for use but not in use. This is referred to as Suspend mode or Standby mode. It means the system is in power-saving status and waiting for user interference.

Warning: To save battery power, it is suggested that the terminal is set to be automatically turned off when not in use. Refer to the [Power Management](#) section for more information about saving power.

3.1.3 Desktop Window

The desktop appears when the terminal is turned on (left below). Tap and hold on the blank area to manage or configure the desktop (right below).







Alternatively, you may tap  to the right of the taskbar, and then select Desktop.



Note: To customize the desktop, tap on the blank area of desktop and select Properties.

When you turn on the terminal and seat it in the cradle for the first time, you will find the following icons displayed on the taskbar:

-  : This icon shows that your cradle is directly connected to a computer via USB port. Make sure you have Microsoft ActiveSync installed on your computer.
-  : There will be two of this icon, one is for BTPAN1 disabled, the other for AX88772 (Ethernet) disabled.
-  : This icon is a shortcut to the Wireless Power Manager that controls the power to 802.11b modules.
-  : This icon shows that the charging progress is ongoing.
-  : This icon shows that numeric mode is in use for data input via keypad.

Start Menu

Tap the Start button on the taskbar to open the Start Menu.

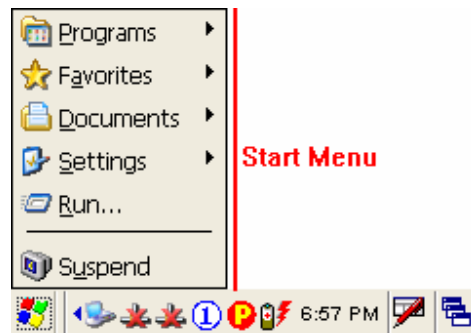

Options	Description
Programs	Provides access to available programs in the directory:

	\Windows\Programs
Favorites	Provides access to your favorites in the directory: \Windows\Favorites
Documents	Provides access to recent opened documents in the directory: \Windows\Recent
Settings	Provides access to <ul style="list-style-type: none"> ◆ Control Panel ◆ Network and Dial-up Connections ◆ Taskbar and Start Menu
Run...	Runs a program or application.
Suspend	Enters the Suspend mode.





Note: To configure the Start menu and taskbar, go to **Start > Settings** and select **Taskbar and Start Menu**.

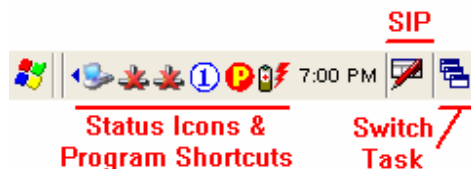









Taskbar

The taskbar is at the bottom of the screen for displaying the **Start** button, up to 6 status icons for various connections or programs, SIP button, Switch Task button, etc.



Note: To configure different connections, go to **Start > Settings** and select **Network and Dial-up Connections**.

Icons	Description
 Connected via USB	The USB connection for ActiveSync operation is successfully established. <ul style="list-style-type: none"> ◆ Double-tap it to view status. Tap [Disconnect] if necessary.
 BTPAN1	The Bluetooth PAN connection fails. (= disconnected)
	The Bluetooth PAN connection is successfully established through the Bluetooth Manager utility. <ul style="list-style-type: none"> ◆ Double-tap it to view or renew IP Information.
 Ethernet via	The Ethernet connection via AX88772 fails. (= disconnected)

	cradle	<p>The Ethernet connection via AX88772 is successfully established once the Cat. 5 cable is connected.</p> <ul style="list-style-type: none"> ◆ Double-tap it to view or renew IP Information.
	Wireless Power Manager	<p>It provides control of the power to the 802.11b.</p> <ul style="list-style-type: none"> ◆ Double-tap any of these icons to configure the power setting.
		<p>It indicates the Wi-Fi module (802.11b) is enabled. See WLAN1 status icons below.</p>
	WLAN1	<p>The Wi-Fi connection fails. (= disconnected)</p> <ul style="list-style-type: none"> ◆ Double-tap it to access the Wireless Information tab for establishing a new connection.
		<p>The Wi-Fi connection is successfully established.</p> <ul style="list-style-type: none"> ◆ Double-tap it to view or renew IP & Wireless Information.
	Bluetooth Manager	<p>It provides access to the Bluetooth services.</p> <ul style="list-style-type: none"> ◆ Initially, you need to double-tap the Bluetooth Manager shortcut on the desktop so that this icon will appear on the taskbar. 
	ReaderConfig	<p>It provides access to the reader configuration utility.</p> <ul style="list-style-type: none"> ◆ Initially, you need to double-tap the ReaderConfig shortcut on the desktop so that this icon will appear on the taskbar. 
	Software Input Panel (SIP)	<p>Tap it to change input method.</p>
	Switch Task	<p>Tap it to switch to desktop or any task, such as a running program or window.</p>

3.1.4 Input Methods

Data entry can be performed by the following methods:

- Type with the 27-key physical keypad
- Scan barcode or RFID tag in applications, e.g. WordPad, CipherLab's Application Generator, etc.
- Tap or write using SIP (Soft Input Panel)

Soft Input Panel (SIP)

Tap the SIP button on the taskbar to select a SIP mode or hide the input panel.



In each mode, the characters appear as typed text on the screen.

SIP Options	Action
Keyboard	To type using the virtual keyboard.
Transcriber	To write freely on the screen in applications, such as WordPad, Inbox, etc.

3.2 System Reset

Reset the 9500CE terminal when it stops responding to input.

- Soft reset: Simply press the [Reset] button.
- Hard reset: Press the [Reset] button and the [Power] key at the same time.

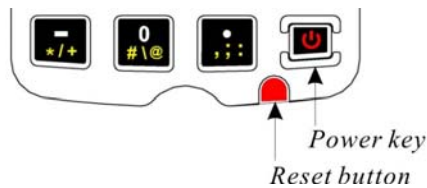

Warning: Never perform a hard reset unless a soft reset cannot solve your problems.

3.2.1 Soft Reset

A soft reset, also known as a warm boot, will restart the terminal and keep all the saved files. To perform a soft reset, use the stylus to press the [Reset] button.

During operation, the removal of battery pack will start a soft reset too.

Warning: Data loss may occur when files are not properly closed before a soft reset.

3.2.2 Hard Reset

A hard reset, also known as a cold boot, will restart the terminal too. However, it performs a full restore of the terminal to its factory settings and initializes SDRAM. To perform a hard reset, press the [Power] key and [Reset] button at the same time.

Data and program files stored in SDRAM will be erased after a hard reset. But you can restore data that is previously synchronized with your computer by performing an ActiveSync operation.

Warning: Only the files stored in the Flash File System are retained during a hard reset.

3.3 Firmware Update

Firmware update should be performed with great caution because everything on the terminal will be erased. Backup user-installed applications and files to your computer first.

The firmware update utility is available on the CD-ROM. To re-install or upgrade the operating system (image file) on your terminal, run the installer “AP.exe” from the CD-ROM. It will create a shortcut of the program “DLDR.exe” on the desktop of your computer.

1. Install Microsoft ActiveSync on your computer. Refer to section 3.4 for initial ActiveSync operation. Then, disable the ActiveSync operation as shown below.

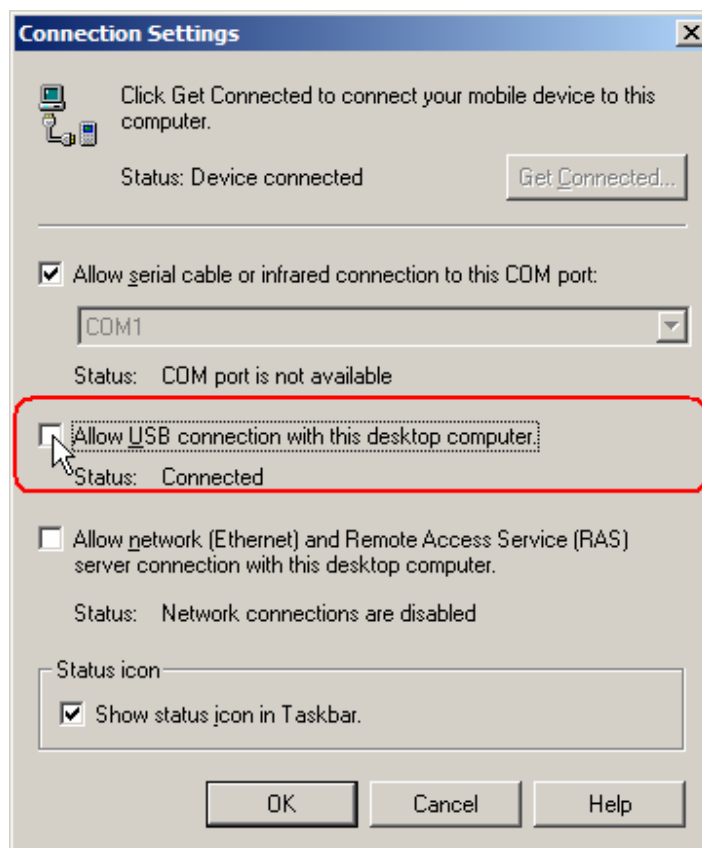

2. Run the installer “AP.exe” from the CD-ROM.
3. Perform a hardware reset on the 9500CE terminal.
4. For the terminal to enter the “Download” mode, press [Space] + [8] + [Power] simultaneously in three seconds.
5. Seat the terminal in the cradle.
6. Run the Image Download program (DLDR.exe) on your computer.

7. Press [Enter] on the terminal to start image update.

It will take approximately 5 minutes to update the image. A message will be displayed on the terminal to indicate the firmware update is completed successfully.

8. Perform a hardware reset on the terminal again.

Warning: Do not press any key on the terminal while updating OS image. Once firmware update is completed, you cannot reload any older image.

3.4 ActiveSync with a Computer

ActiveSync is used to synchronize information between the terminal and PC, to install programs on the terminal, and to backup and restore the terminal.

The Microsoft ActiveSync program has to be installed on your desktop computer first.

- To download the up-to-date version of the program, you may need to go to Microsoft's official web site for Windows Mobile devices as shown below.

<http://www.microsoft.com/windowsmobile/default.mspx>

- After downloading and installation, run the program.

For detailed information on the program, you may click the Help menu, and then select the Microsoft ActiveSync Help.

Note: We recommend that you have ActiveSync 3.7.1 installed on your computer because ActiveSync 4.x does not officially support Windows CE 5.0 devices.

1. Follow these instructions for initial ActiveSync operation:

- Connect the USB cable from the cradle's USB Client port () to your computer.
- Connect the power cable from the cradle to a nearby power outlet.
- Turn on the 9500CE terminal and seat it in the cradle.

2. Your computer will automatically detect the USB device. Click [OK] when the connection is established.

3. Select which partnership to set up.

If you want to synchronize data between 9500CE and your computer, select Standard Partnership; otherwise, select Guest Partnership.

4. Wait a few seconds for 9500CE to get connected (and synchronized if a Standard Partnership is selected).

3.5 Quick Launch a Program

Tap the **Start** button to view the **Start Menu**. To quick launch a program, tap it from the **Programs** folder.



Note: Alternatively, you may tap **Start** and select **Run** to run a specific program or open a document.

To add a new program or subfolder to the **Programs** folder, you can either use **Windows Explorer** or **ActiveSync**.

- **Windows Explorer:** to move the program by [Copy] and [Paste Shortcut].
- **ActiveSync on the desktop computer:** to create a shortcut to the program, and place the shortcut in the **Programs** folder.

Warning: To avoid making any changes to the program configurations by accident, we recommend you to use [Copy] and [Paste Shortcut] rather than [Cut] and [Paste].

3.5.1 Add a Program

If you wish to quick launch a new program, add it to the **Programs** folder: `My Device\Windows\Programs`

Using Windows Explorer

1. Go to **Start > Programs**, and select **Windows Explorer**. Alternatively, you can press the [Task] key on the keypad to launch **Windows Explorer**.
2. Navigate through file folders to find the program you desire.

3. Tap and hold the program, and then tap [Copy] on the pop-up menu.

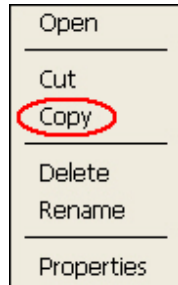

4. Navigate to the Programs folder (My Device\Windows\Programs).

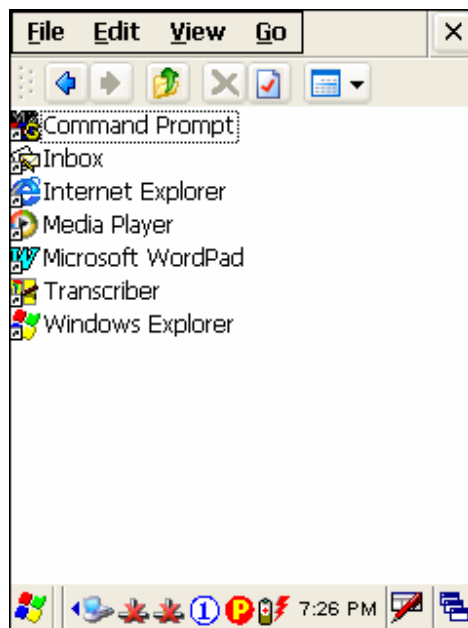

5. Tap and hold anywhere blank on the screen. Then tap [Paste Shortcut] on the pop-up menu. The new program will be added to the Programs folder.



6. Go to Start > Programs and the new program will appear now.

Using ActiveSync on PC

1. When connected, open the Microsoft ActiveSync window on your desktop computer.
2. Click the Explorer button from the toolbar.

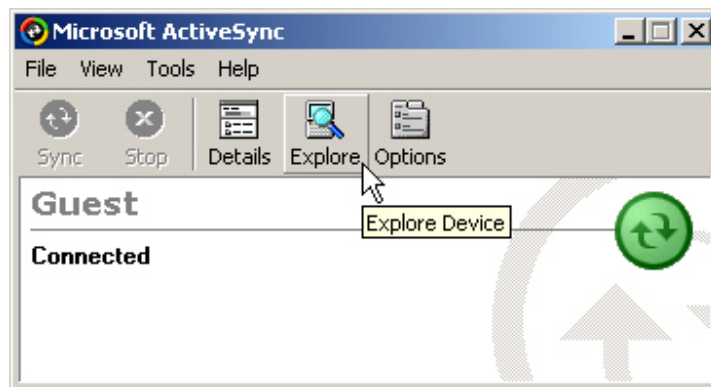

3. Navigate through file folders to find the program you desire.

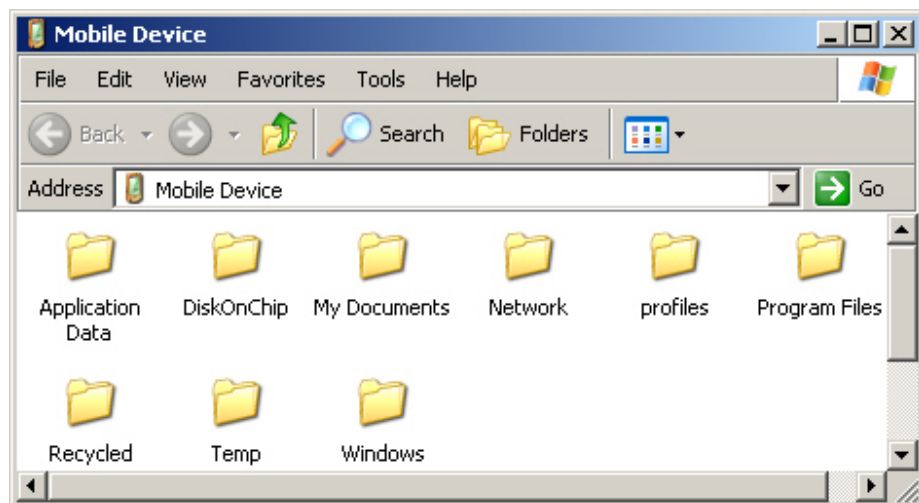

4. Right-click the program, and then select [Create Shortcut] on the pop-up menu.
5. Right-click the shortcut, and then select [Cut] on the pop-up menu.
6. Navigate to the Programs folder (My Device\Windows\Programs).
7. Right-click anywhere blank on the window. Then select [Paste] on the pop-up menu. The new program will be added to the Programs folder.
8. On the terminal, go to Start > Programs and the new program will appear now.

Note: [Create Shortcut], [Cut], and [Paste]: The same result can be performed by [Copy] and [Paste Shortcut].

3.5.2 Add a Subfolder

Using Windows Explorer

1. Go to Start > Programs, and select Windows Explorer. Alternatively, you can press the [Task] key on the keypad to launch Windows Explorer.
2. Navigate through file folders to find where you wish to create a new folder.
3. Right-click anywhere blank on the window, and select [New Folder] from the pop-up menu. A subfolder will be created.

Using ActiveSync on PC



1. When connected, open the Microsoft ActiveSync window on your desktop computer.
2. Click the Explorer button from the toolbar.
3. Navigate to the target folder where you wish to create a new folder.
4. Right-click anywhere blank on the window, and select [New Folder] from the pop-up menu. A subfolder will be created.

3.5.3 Exit a Program

In general, the system manages memory automatically, and there is no need to exit a program in order to open another or to conserve memory. However, random access memory (SDRAM) may be used up when running too many programs. As a result, it will slow down the operation or cause program errors. In that case, you should stop one or more running programs to free memory.

In order to use memory in a more efficient way, you are recommended to exit a program when it is not desired any longer.

Warning: Always remember to save data or settings before you exit a program.

To close an active window, a dialog box, or a running application, tap  or  when it is available on the toolbar. If the Close button is not displayed, press [ESC] on the physical keypad to exit.

Note: Some programs, such as the Bluetooth Manager, may create an associated icon on the taskbar. You may tap the icon and select [Exit] from the pop-up menu.

To save current settings and exit, tap  when it is available on the toolbar.

3.5.4 Switch between Programs

Tap  to the right of the taskbar, and then select a running program.

3.6 Install a New Program

3.6.1 Add/Remove Programs

To install a program that is designed to be used on a mobile device running Windows CE, you may click [Add/Remove Programs] from the Tools Menu.

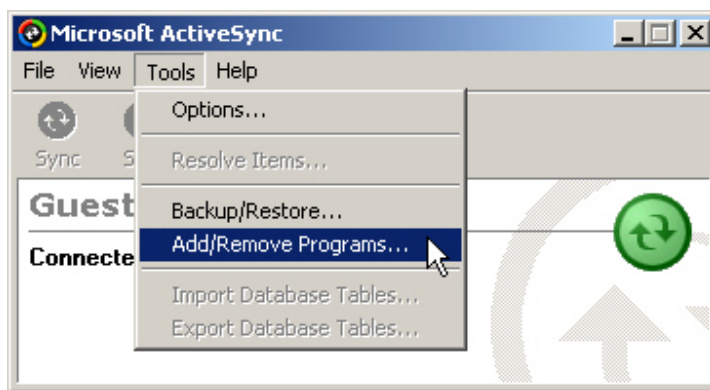

3.6.2 Copy & Paste

Alternatively, you may install a new program manually.

1. When connected, open the Microsoft ActiveSync window on your desktop computer.
2. Click the Explorer button from the toolbar.
3. Navigate to the target folder, e.g. the Programs folder, depending on where you wish to access the program.
4. Navigate through file folders on your computer to find the new program.
5. Right-click the program and select [copy] on the pop-up menu.
6. Back to the target folder in step 3. Right-click anywhere blank and select [Paste] on the pop-up menu.
7. On the terminal, go to **Start > Programs** and the new program will appear.

3.7 Uninstall a Program

If a user program is no longer desired, you may remove it from the system.

3.7.1 ActiveSync: Add/Remove Programs

To uninstall a program that is designed to be used on a mobile device running Windows CE, you may click [Add/Remove Programs] from the Tools Menu.

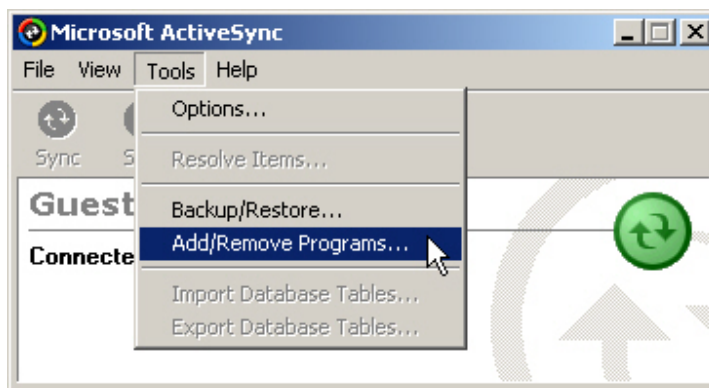

3.7.2 Control Panel > Remove Programs

Alternatively, you may uninstall a new program manually.



1. Go to Start > Settings > Control Panel, and double-tap the Remove Programs icon.
2. Tap the name of the program that you want to delete.
3. Tap [Remove].
4. Tap [Yes] to uninstall the program.

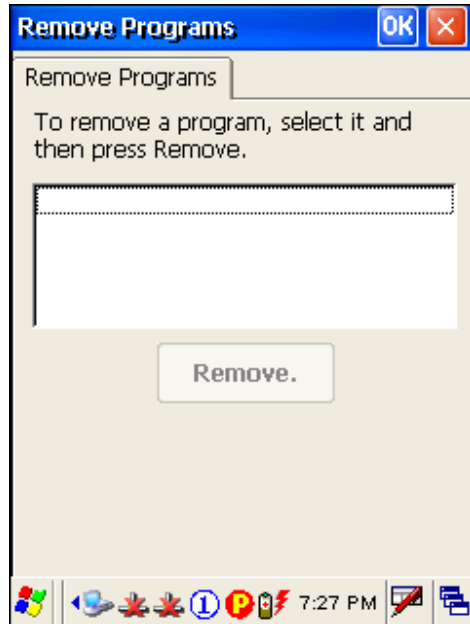

Note: If the program does not appear in the list of installed programs, you may use Windows Explorer to locate it. Tap and hold the program, and select [Delete].

3.8 Backup & Restore Programs

To best protect your work, you should regularly back up information on your terminal. You can perform a backup by during the ActiveSync operation. The backup file is stored on your desktop computer.

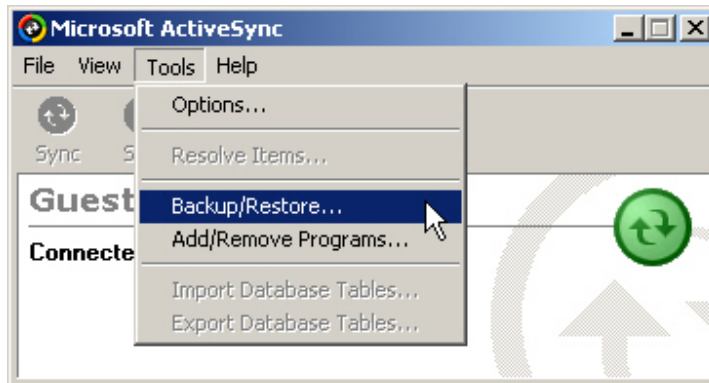

CHAPTER 4

Configuration







In this chapter, a brief on the system settings is provided for your reference.









Note: User settings are stored in SDRAM and will be overwritten by the system defaults after a hard reset.



4.1 General Settings

Go to Start > Settings > Control Panel.



Items	Description
 Accessibility	<p>In the [Accessibility] dialog box, you may use these options to customize the way an external keyboard, display, or mouse functions. Many of these features are useful to people without disabilities</p> <ul style="list-style-type: none"> ◆ Keyboard tab: Select StickyKeys to enable simultaneous keystrokes while pressing one key at a time; select ToggleKeys to emit sounds when certain locking keys are pressed. ◆ Sound tab: Select SoundSentry to provide visual warnings for system sounds. ◆ Display tab: Select High Contrast to improve screen contrast with alternative colors. ◆ Mouse tab: Select MouseKeys to enable the keyboard to perform mouse functions ◆ General tab: Select Automatic Reset if you wish to turn off accessibility features after a specific period of time; select Notification if you wish to hear a sound when turning a feature on or off.
 Certificates	<p>In the [Certificates] dialog box, you may view or modify digital certificates that some application use to establish trust for secure connections.</p>
 Date/Time	<p>In the [Date/Time] dialog box, you may change date, time, and time zone settings.</p>
 Display	<p>In the [Display Properties] dialog box,</p> <ul style="list-style-type: none"> ◆ Background tab: Select an image for the background. ◆ Appearance tab: Select a desired color scheme for windows, dialog boxes, and items. ◆ Backlight tab: Specify for how long the terminal is idle and then the backlight will be automatically turned off while on battery power and external power (in the charging cradle) respectively. Tap the [Advanced] button to move the slider and adjust the brightness of the LCD backlight when it is set to be automatically turned on once a key is pressed or you tap the touch screen.
 Input Panel	<p>In the [Input Panel Properties] dialog box, you may configure how the Soft Input Panel (SIP) works.</p>
 Internet Options	<p>In the [Internet Options] dialog box, you may configure how the terminal connects to the Internet.</p>
 Keyboard	<p>Connect an external keyboard to the cradle via the USB Host port.</p> <p>In the [Keyboard Properties] dialog box, you may configure settings for character repeat.</p>

 Mouse	<p>Connect a mouse to the cradle via the USB Host port.</p> <p>In the [Mouse Properties] dialog box, you may configure and test your double-click settings.</p>
 Network and Dial-up Co...	<p>In the [Network and Dial-up Connections] window, you may configure settings for the terminal connects to a network directly or through a modem. Alternatively, you may tap Start > Settings > Network and Dial-up Connections.</p> <ul style="list-style-type: none"> ◆ USB Connection (via USB client port on the cradle) ◆ AX88772 (via Ethernet port on the cradle) ◆ WLAN (via 802.11b) ◆ BTPAN (via Bluetooth)
 Owner	<p>In the [Owner Properties] dialog box,</p> <ul style="list-style-type: none"> ◆ Identification/Notes tab: Enter your contact information or notes. ◆ Network ID tab: Enter the user name, password, and domain name used to log on to the remote network.
 Password	<p>In the [Password Properties] dialog box, you may apply password protection to limit access to the terminal.</p>
 PC Connection	<p>In the [PC Connection Properties] dialog box, you may disable the direct connection between the terminal and a computer.</p> <p>By default, the terminal is enabled to directly connect to a computer via the cradle's USB port. Alternatively, you may tap Start > Settings > Network and Dial-up Connections and select USB Connection.</p>
 Power	<p>In the [Power Properties] dialog box,</p> <ul style="list-style-type: none"> ◆ Battery tab: You may view the current status of main and backup batteries. ◆ Schemes tab: You may configure the power scheme and switching. ◆ Device Status tab: You may view the devices that are consuming power.
 Regional Settings	<p>In the [Regional and Language Settings] dialog box,</p> <ul style="list-style-type: none"> ◆ Region tab: You may customize the appearance and formatting to your geographic region. ◆ Language tab: By default, it is set to English (United States). ◆ Input tab: By default, it is set to English (United States)-US.
 Remove Programs	<p>In the [Remove Programs] dialog box, you may remove any program that is installed earlier.</p>
 Stylus	<p>In the [Stylus Properties] dialog box,</p> <ul style="list-style-type: none"> ◆ Double-Tap tab: You may configure and test your double-tap settings. ◆ Calibration tab: You may need to re-calibrate the touch screen if it is not responding properly to your taps.

 System	In the [System Properties] dialog box, <ul style="list-style-type: none"> ◆ General tab: You may view the system information. ◆ Memory tab: You may move the slider and adjust the SDRAM allocation. ◆ Device Name tab: You may enter a name and description for identifying the terminal. ◆ Copyrights tab: You may view the important statements on copyrights.
 Volume & Sounds	In the [Volume & Sounds Properties] dialog box, <ul style="list-style-type: none"> ◆ Volume tab: You may move the slider and adjust the volume and select to play sounds for Events, Applications or Notifications. ◆ Sounds tab: You may configure sounds for different Windows events.









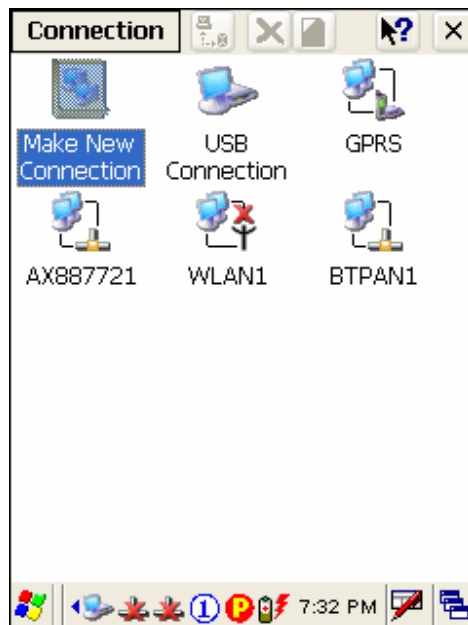



4.2 Connections



There are two ways to access the connections settings:

- Go to **Start > Settings > Control Panel** and double-tap the Network and Dial-up Connections icon.
- Go to **Start > Settings > Network and Dial-up Connections**.



Type of Connections	Description	See Also
 USB Connection	This is a shortcut to USB Connection, and the selected interface is USB for factory setting. This connection is reflected in the control panel for direct PC connection.	Start > Settings > Control Panel > 
 AX887721	This is the control of Ethernet module AX88772, which is enabled by default.	
 WLAN1	This is the control of 802.11b module for wireless local area networking (WLAN) connection, which is disabled by default.	
 BTPAN1	This is the control of Bluetooth module for wireless personal area networking (WPAN) connection, which is enabled by default.	
Toolbar	Description	See Also
	Tap this button to open the Connection menu. The available options depend on the connection you select.	Tap and hold the icon of a desired connection type. Then, select from its associated menu.
	Tap this button to toggle on/off the connection you select. The toggle is used for Enable/Disable or Connect/Disconnect.	
	Tap this button to delete the connection you select.	
	Tap this button to view the properties of the connection you select.	

4.2.1 USB Connection

Tap and hold on “USB Connection”.

- Most options can be found in the Connection menu on the toolbar as well.

When you select [Set as Default], the USB Connection will become the default connection used for browsing the Internet.

Note: Please ignore [Properties] as the associated settings will not take effect.

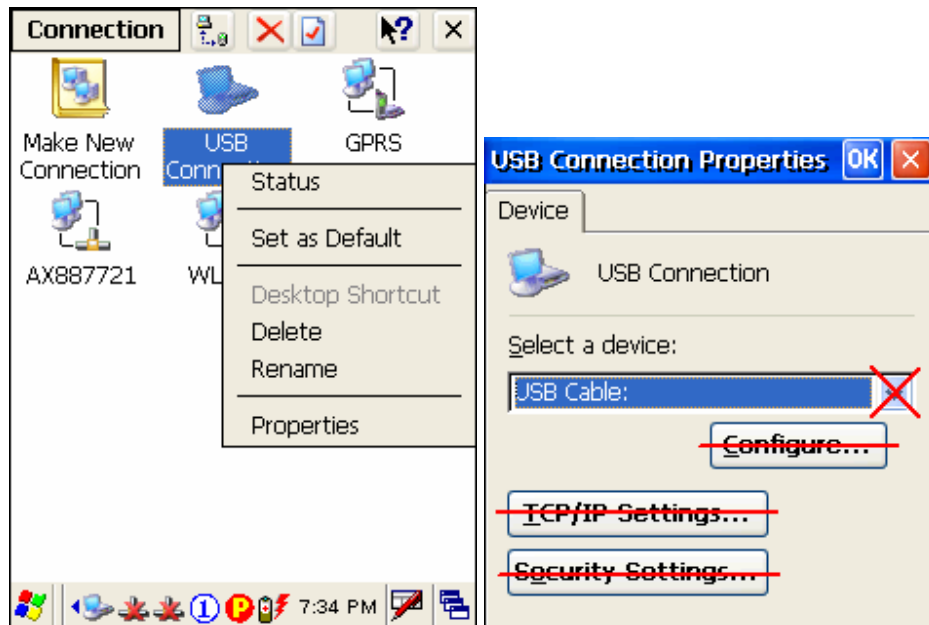

Connect / Disconnect

The USB connection is specifically for performing the ActiveSync operation. Generally, it will automatically establish the connection and start the ActiveSync operation when you seat the terminal in the cradle. To stop the ActiveSync operation, simply remove the terminal.

If you want to stop the ActiveSync operation without removing the terminal from the cradle, tap and hold on “USB Connection”, and select [Status]. Then, tap [Disconnect] in the dialog box.



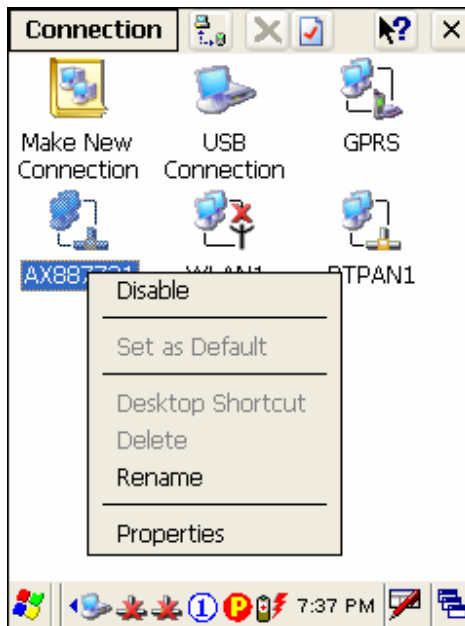

- When connected, the status icon  will appear on the taskbar.
- When disconnected, this icon will disappear.

4.2.3 AX88772 (Ethernet)

Tap and hold on “AX887721”.



Enable / Disable

Icons	Description
 AX887721	By default, the Ethernet module is enabled. When a Cat. 5 cable is connected, the status icon  will become  .
 AX887721	Tap and hold on “AX887721”, and select [Disable]. The status icon will disappear.

Properties

By default, DHCP is enabled, and therefore, there is no need to configure the IP settings. If you want to assign a static IP address to the terminal, tap and hold on “AX887721”, and then select [Properties].



Note: Only change these settings according to your network administrator’s instructions.

4.2.4 WLAN

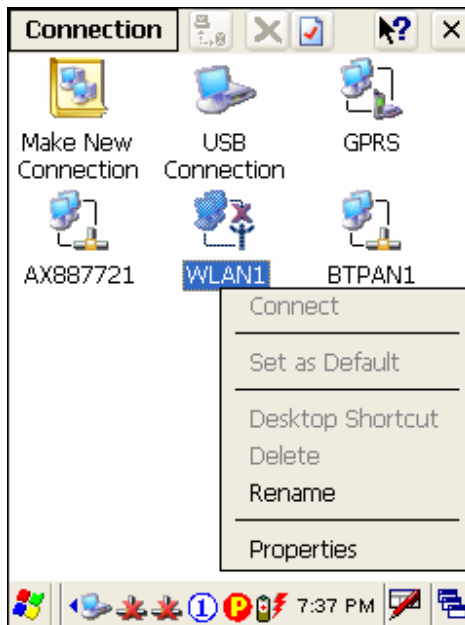
Tap and hold on “WLAN1”.



Connect / Disconnect

1. Turn on the power to the 802.11b module through the Wireless Power Manager. Its associated icon  on the taskbar will become . The WLAN1 dialog box appears for establishing a connection.

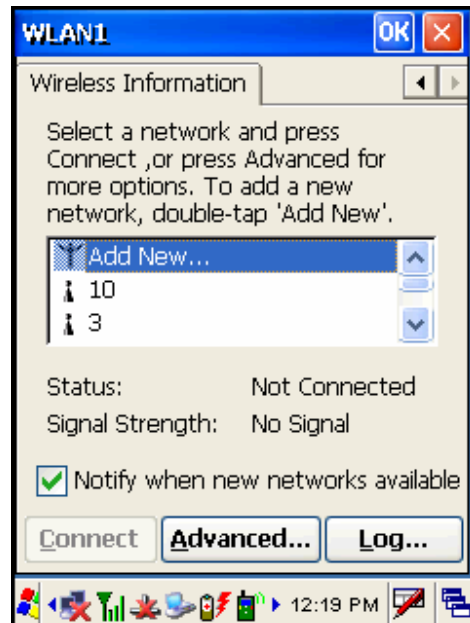

2. Select an access point or Wi-Fi enabled device, and tap the [Connect] button.

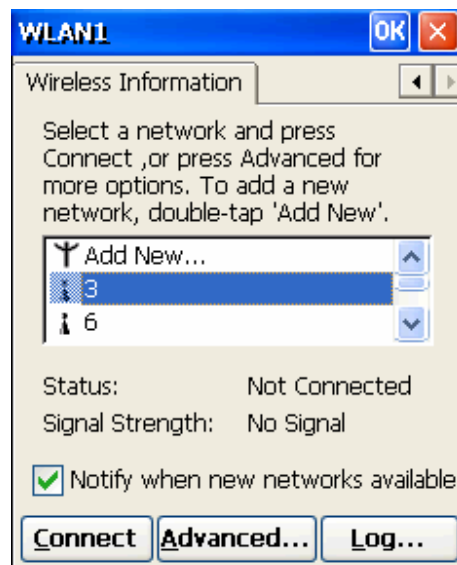

For initial connection, the Wireless Properties dialog box will appear first. Tap [OK] after configuration.

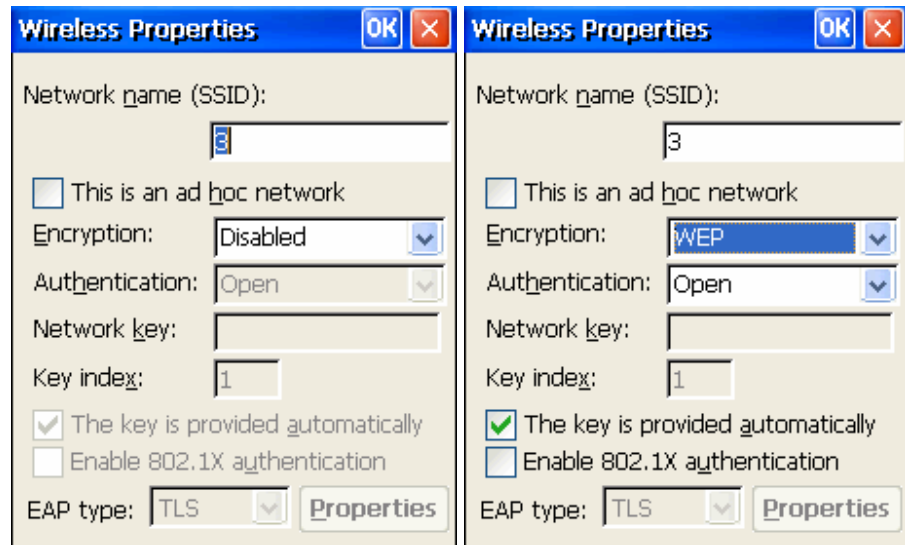



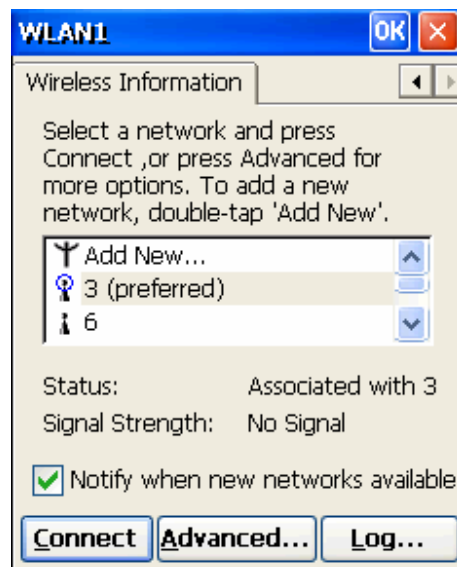



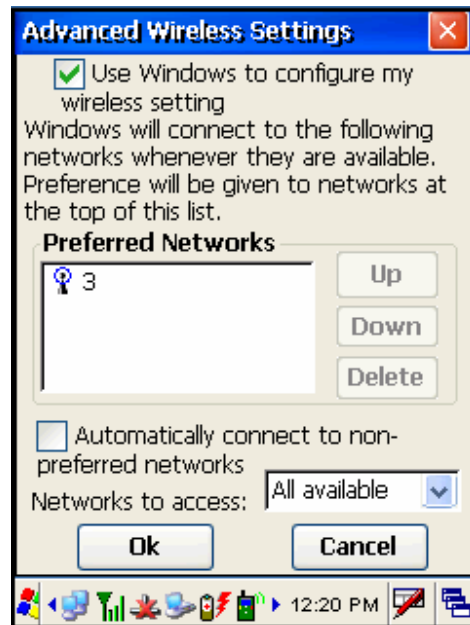

3. Wait a few seconds for the terminal to connect to the selected network.



4. If you need to change the network settings, double-tap the selected network. The Wireless Properties dialog box appears as shown in step 2. Tap [OK] after configuration.

For more network settings, tap the [Advanced] button on the Wireless Information tab.



Icons	Description
 WLAN1	By default, the 802.11b module is disabled. No status icon.
 WLAN1	Enable the 802.11b module through the Wireless Power Manager . The icon  on the taskbar will become  , and the status icon  will appear. When successfully connecting to an access point or other Wi-Fi enabled device, the status icon  will become  .

Properties

By default, DHCP is enabled, and therefore, there is no need to configure the IP settings. If you want to assign a static IP address to the terminal, tap and hold on “WLAN1”, and then select [Properties].



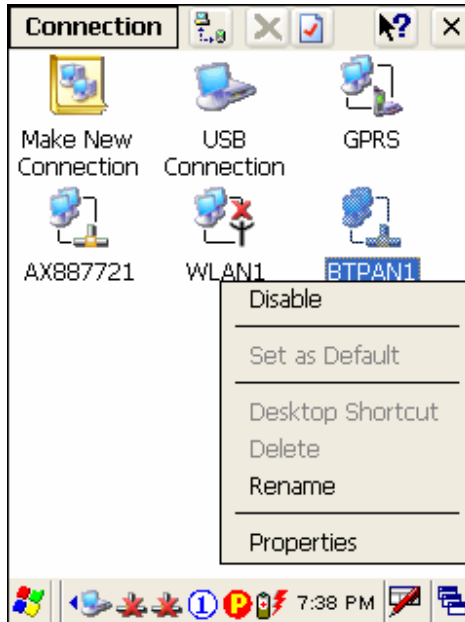

Note: Only change these settings according to your network administrator’s instructions.

4.2.5 BTPAN

Tap and hold on “BTPAN1”.



Enable / Disable

Icons	Description
 BTPAN1	By default, the Ethernet module is enabled. When the Bluetooth PAN service is connected through the Bluetooth Manager, the status icon  will become  .
 BTPAN1	Tap and hold on “BTPAN1”, and select [Disable]. The status icon will disappear.

Properties

By default, DHCP is enabled, and therefore, there is no need to configure the IP settings. If you want to assign a static IP address to the terminal, tap and hold on “BTPAN1”, and then select [Properties].

Note: Only change these settings according to your network administrator’s instructions.

CHAPTER 5

Applications

The 9500CE terminal provides several utilities and key applications which are made accessible from the desktop or the taskbar.

- **Wireless Power Manager** lets you determine whether the power is supplied to the WLAN module, along with its associated driver installed.
- **Bluetooth Manager** lets you configure the Bluetooth settings and use the Bluetooth services provided on the remote devices.
- **ReaderCfg** lets you manage the barcode or RFID reader.
- **Inbox** lets you send and receive e-mail by connecting to a POP3 or IMAP4 server.

5.1 Wireless Power Manager

Wireless Power Manager is a control panel applet, which allows you to choose and enable 802.11b.

Note: Meanwhile, you may enable Bluetooth connectivity through the Bluetooth Manager.

1. Double-tap the associated icon  on the taskbar to run Wireless Power Manager.

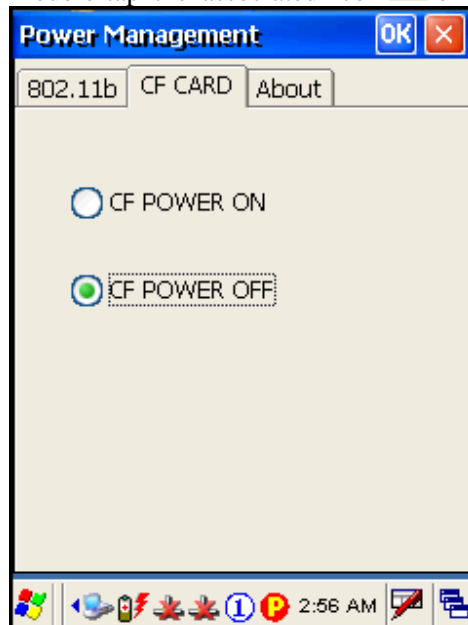

2. Select the wireless connectivity you desire, and then tap . It takes several seconds to turn on the power to the wireless module and install the driver. When 802.11b are enabled on battery power, the main battery charge will drop down substantially.

Double-tap any of the following icons to access power management.

	The icon indicates that 802.11b Power is turned on.
---	---

Note: You may need to turn off the wireless power or simply stop the wireless signals at times, in order to conserve battery power, or in situations where the use of radio is prohibited, such as on airplanes, in hospitals, etc.

5.2 Bluetooth Manager

Bluetooth Manager is a utility that helps you access and manage the available Bluetooth services efficiently.

The supported Bluetooth profiles are:

- Serial Port Profile (SPP)
- Object Push Profile (OPP)
- File Transfer Profile (FTP)
- Dial-Up Networking Profile (DUN)
- PAN Service Profile (PAN)
- Human Interface Device Profile (HID)









5.2.1 Start Bluetooth Services



1. Double-tap the Bluetooth Manager shortcut on the desktop (left below).
2. It takes several seconds to enable the Bluetooth services. The associated icon  will appear on the taskbar. (right below)



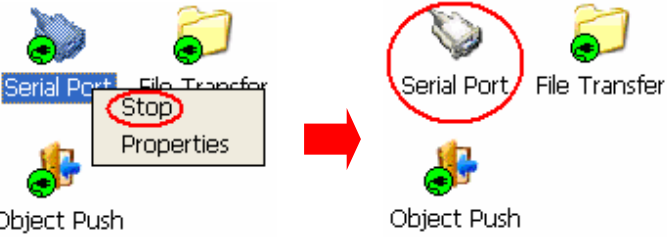



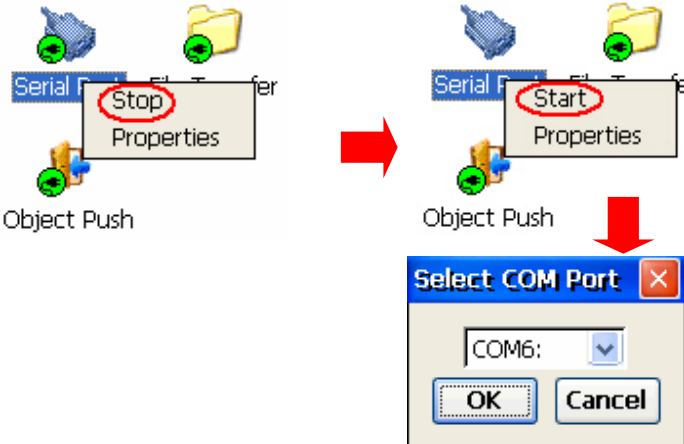
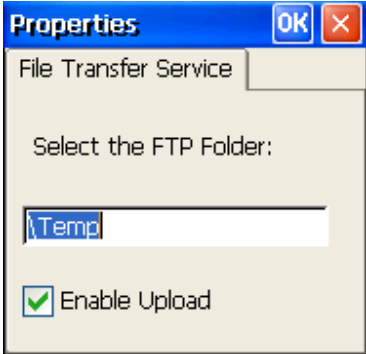
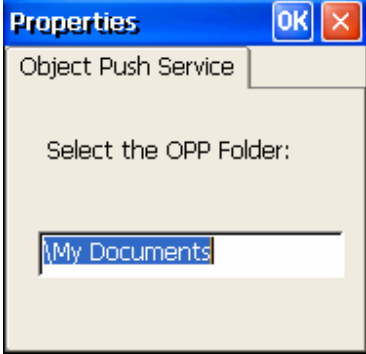



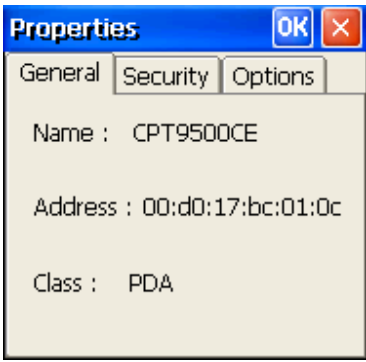

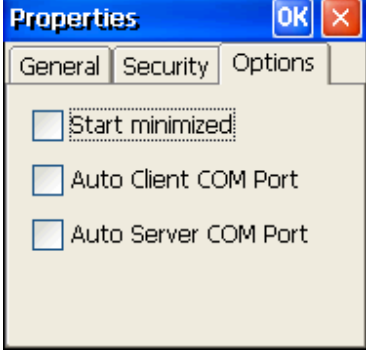

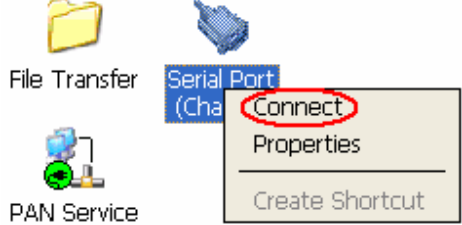

Note: To start Bluetooth PAN service, go to Start > Settings > Network and Dial-up Connections.

Toolbar

Buttons	Description	See Also
 <p>Q_Link</p>	<p>Tap this button to view shortcuts to preferred Bluetooth services, which may be provided on different Bluetooth devices. Then tap a desired Bluetooth service to establish a quick link.</p> <p>You will have to make a connection and created a shortcut to a specific Bluetooth service first.</p>	
 <p>Device</p>	<p>Tap this button to view the Bluetooth devices discovered during this session.</p> <ul style="list-style-type: none"> If you tap the button for the first time, it will start the inquiry process to discover nearby Bluetooth devices. 	 
 <p>Service</p>	<p>Tap this button to view the Bluetooth services provided.</p> <ul style="list-style-type: none"> By default, these services are all available, and therefore, displayed along with a plug icon “”. To view properties of a service, tap and hold it. Then select [Properties]. To disable a service, tap and hold it. Then select [Stop]. 	
<p>Serial Port Properties</p>	<p>If “Auto Server COM Port” is enabled –</p>  <p>If “Auto Server COM Port” is disabled, you can select a COM port by following these steps:</p>	 <p>Setting</p>

		
<p>File Transfer Properties</p>	<p>You can change the FTP folder.</p> <ul style="list-style-type: none"> By default, uploading files to the terminal is allowed. You can cancel the check box to prohibit uploading. 	
<p>Object Push Properties</p>	<p>You can change the Bluetooth exchange folder.</p> 	
 <p>Setting</p>	<p>Tap this button to view the Bluetooth properties.</p>	
<p>General tab</p>	<p>It displays device name, MAC address, as well as the device type.</p>	

	 <p>If you wish to change the device name of the terminal, go to Start > Settings > Control Panel and select System.</p>	
<p>Security tab</p>	 <ul style="list-style-type: none"> ◆ Authentication Setting: It is disabled by default. When enabled, PIN code is required. ◆ Discoverability: It is set discoverable by default. If you do not wish to provide Bluetooth services to other remote devices, cancel the check box. ◆ Default PIN: It is disabled by default. You may set a link key to skip the PIN code input. 	
<p>Options tab</p>	 <ul style="list-style-type: none"> ◆ Start minimized: When selected, once you run the Bluetooth Manager program, its window will be minimized to an icon  on the taskbar, which serves as a toggle to open or close the Bluetooth Manager window. It works the same as the “Minimized” button below. ◆ Auto Client COM Port: When enabled, the default COM port for 	

	<p>remote Serial Port service will be assigned automatically. When disabled, you can select a COM port by selecting [Connect]:</p>  <ul style="list-style-type: none"> ◆ Auto Server COM Port: When enabled, the default COM port for local Serial Port service will be assigned automatically. 	 Service
	<p>Tap this button to minimize the Bluetooth Manager window.</p>	 Setting
	<p>Tap this button to exit the Bluetooth Manager.</p>	
	<p>Tap this button to stop inquiring.</p>	 Device
	<p>Tap this button to refresh the device list.</p>	 Device
	<p>When using the File Transfer service on a remote device, you can tap this button to move up one level if a subfolder exists.</p>	
 About	<p>Tap this button to view the Bluetooth profiles supported:</p> <ul style="list-style-type: none"> ◆ SPP for Serial Port Profile ◆ OPP for Object Push Profile ◆ FTP for File Transfer Profile ◆ DUN for Dial-Up Networking Profile (supports Client only) <p>Note that the terminal also supports the following profiles:</p> <ul style="list-style-type: none"> ◆ PAN Service Profile ◆ Human Interface Device (HID) Profile 	

5.2.2 Inquiry

1. Tap  to discover nearby Bluetooth devices.

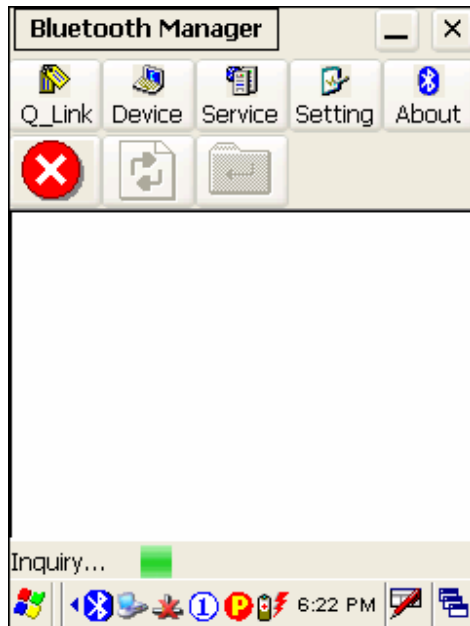

2. It will list the discovered devices.



5.2.3 Pair

When authentication is enabled on the target device, you will have to pair with it before starting a connection.

1. From the device list, tap and hold on the desired device and tap [Pair].

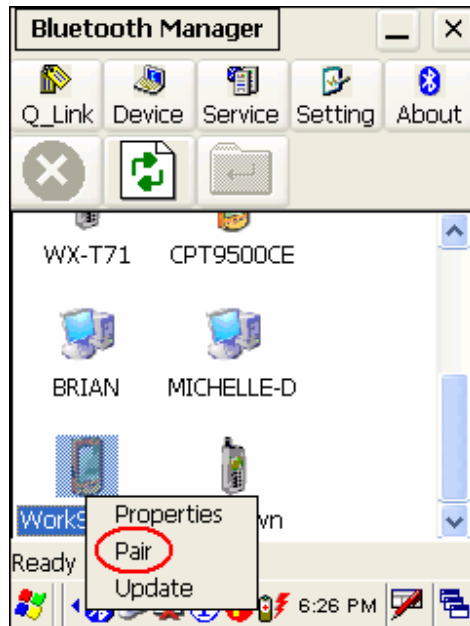

2. Enter the PIN code that is specified on the remote device.



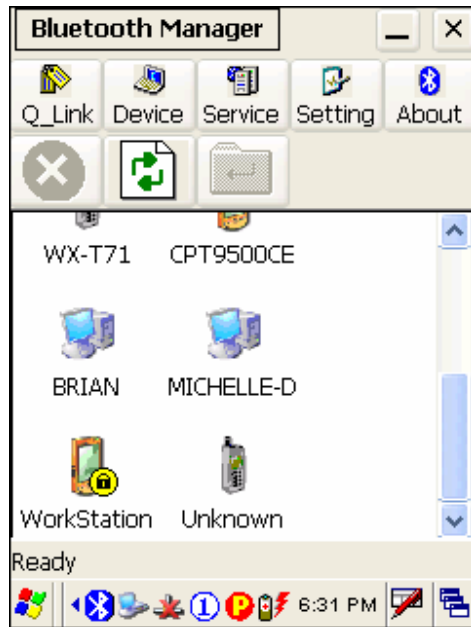

3. Once paired successfully, the paired device will be displayed along with a lock icon “🔒”.

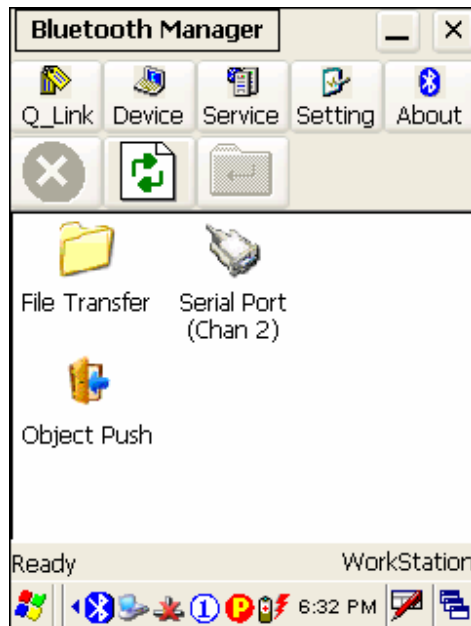

5.2.4 Connect

1. From the device list above, double-tap a device to find out the available Bluetooth services.



2. Tap and hold a desired Bluetooth service, e.g. Serial Port Service, to establish a connection. The connected service will be displayed along with a plug icon “”.

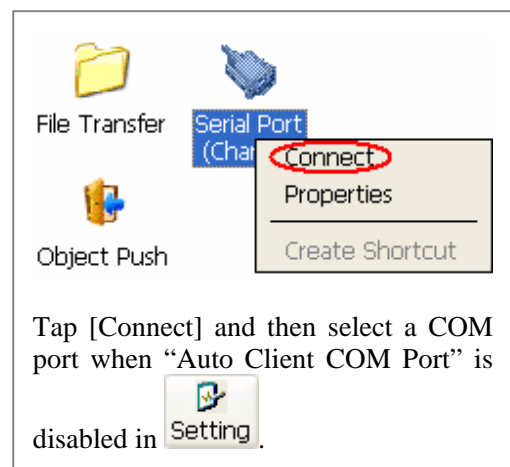
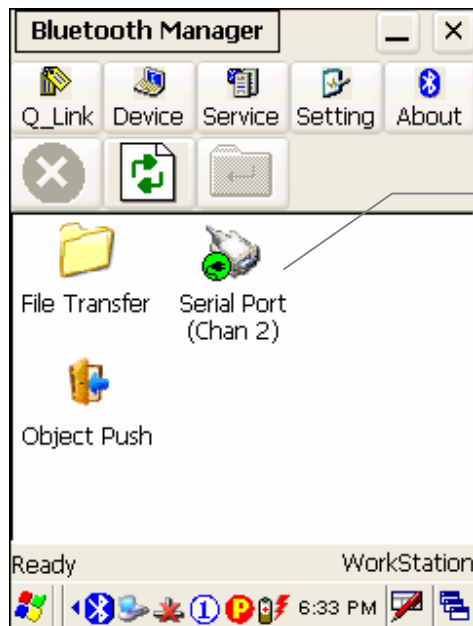

3. If you wish to add a service to the Q_Link list for establishing a quick connection in the future, tap and hold it, and then select [Create Shortcut].



Steps to access the Object Push service:

1. Tap and hold the Object Push service.
2. Select [Push file] to send a file or PIM item, e.g. a business card.

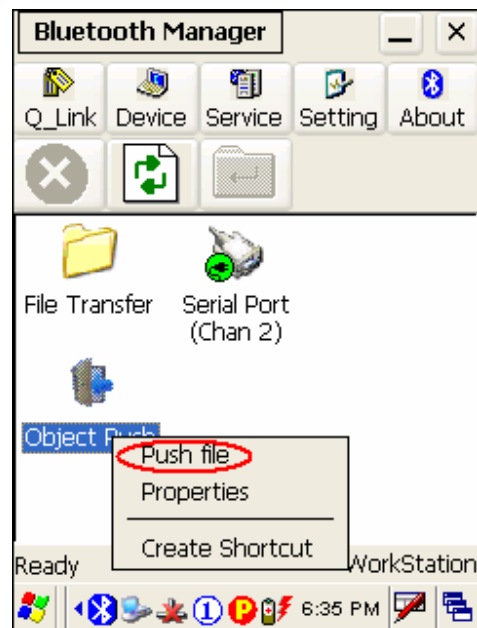

3. Choose the file you wish to send.

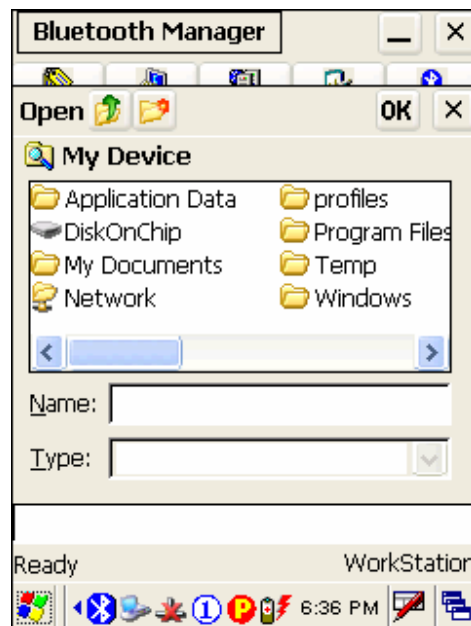

4. The terminal will start transferring the file.

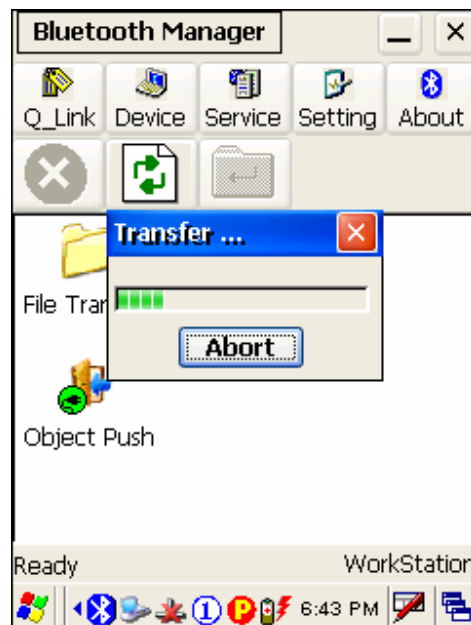

Steps to access the File Transfer service:

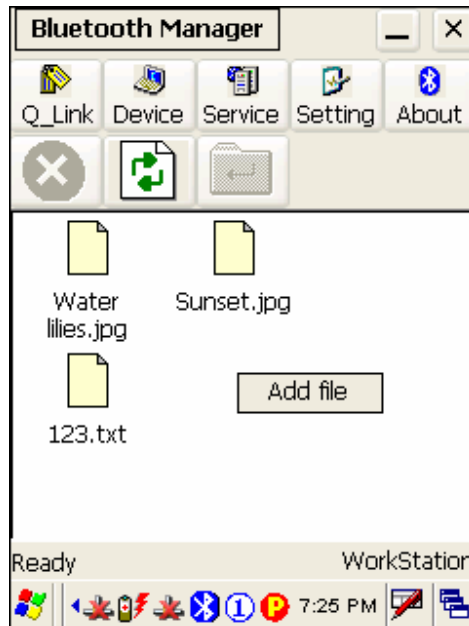

1. Tap and hold the File Transfer service.
2. Select [Connect] (and assign COM port if necessary).
3. Tap and hold on anywhere blank. Then, select [Add file].

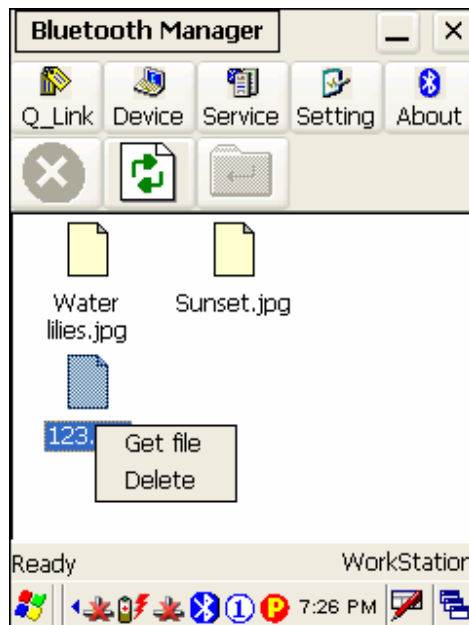

4. Choose the file you wish to upload to the remote device.
5. The terminal will start transferring the file.
6. To download a file from the remote device, tap and hold on a desired file. Then, select [Get file].



5.2.5 Stop Bluetooth Services

Tap  on the toolbar of the Bluetooth window to stop all Bluetooth connections. When the Bluetooth window is minimized, tap and hold  on the taskbar, and then select [Exit].



Note: You may need to stop using the Bluetooth services, in order to conserve battery power, or in situations where the use of radio is prohibited, such as on airplanes, in hospitals, etc. To stop Bluetooth PAN service, go to **Start > Settings > Network and Dial-up Connections**.

5.3 ReaderConfig

ReaderConfig is the control applet and tool to manage the barcode and RFID readers integrated on the terminal.

1. Double-tap the ReaderConfig shortcut on the desktop. The associated icon  will appear on the taskbar.



2. Tap and hold on the icon to access the menu that allows you to choose and enable one or both of the readers. There will be a check mark in front of the reader if it is enabled.
 - BC Reader: 1D or 2D
 - RFID Reader
3. To meet your application requirements, proceed to configure associated reader settings.

Note: The program ReaderCfgr will automatically detect the reader module(s) that is currently installed in the terminal.

5.3.1 Configure Reader Settings

Tap and hold on , and then select BC Reader or RFID Reader. If it is ticked, the reader is enabled. Otherwise, it is disabled.

The default reader is BC Reader for reading barcodes. If the RFID Reader is installed, the option will be available. If you need to change the factory settings, select [Settings].

The reader configurations depend on the barcode reader installed. To identify the barcode reader, check inside the “Active Device” setting.

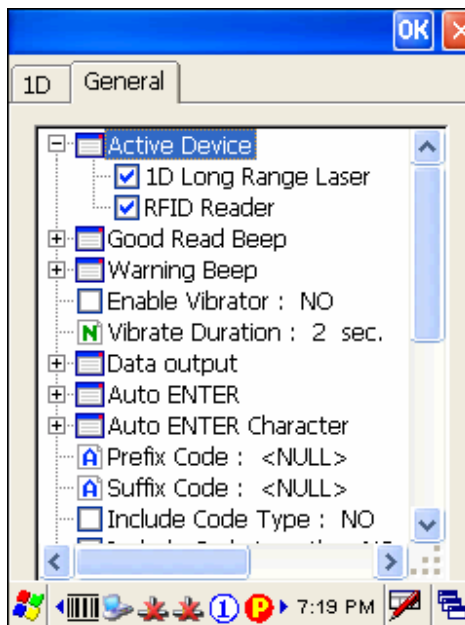

Active Device	Description
1D Reader	The scan engine is CCD or Laser.
1D Long Range Laser	The scan engine is Long Range Laser or Extra Long Range Laser.
2D Reader	The scan engine can read linear and 2D barcodes.
RFID	The reader can read RFID tags.

Note: (1) For barcode settings, click the 1D or 2D tab that is next to the General tab.
 (2) For RFID settings, click the General tab and roll to the bottom of the list.
 (3) If you wish to reload the default settings, delete the ReaderCfg.ini file in DiskOnChip.

5.3.2 1D Reader - CCD / Laser

General tab

Settings		Default
Active Device	The scan engine can be identified and toggled. Only one scan engine can be disabled at a time. <ul style="list-style-type: none"> ◆ 1D Reader ◆ RFID 	Barcode Reader is always enabled if exists.
Good Read Beep	Mute, or Sound 1~9	Sound 2
Warning Beep	Mute, or Sound 1~9	Sound 9
Enable Vibrator	YES or NO	NO (Disabled)
Vibrator Duration	1~30 (sec.) *Vibrator must be enabled.	2 seconds
Data Output	There are three options for data output after decoding: <ul style="list-style-type: none"> ◆ Keyboard Emulation <ul style="list-style-type: none"> - Data is emulated as typed text and sent to the active Window. - Simply run your application or Pocket PC built-in program, such as Pocket Excel, to start with data collection. ◆ Windows Message <ul style="list-style-type: none"> - Data is encapsulated in a Windows message (WM_COPYDATA). - Retrieve the WM_COPYDATA message in your application. - The decoded data is passed to your application through the IParam parameter. ◆ Windows Event <ul style="list-style-type: none"> - Whenever the reader reads a barcode, a Windows event object named "DecodeEvent" will be signaled and the data will be stored in the Windows message queue. - Need to create an event object named "DecodeEvent" in your application so that the ReaderCfg utility can signal your application using this event object. - Call Windows API (ReadMsgQueue) in your application to retrieve the decoded data. <p>*Sample programs are provided for Windows Message & Event programming. For details, please contact CipherLab technical support team.</p>	Keyboard Emulation

Note: For the use of a different program rather than ReaderCfg, a dynamic-link library (DLL) file is provided.

Auto ENTER	<p>This function can spare you the trouble of pressing the [Enter] key on the terminal to confirm each scan. It will automatically add an ENTER character in front or to the end of one scan.</p> <ul style="list-style-type: none"> ◆ No ◆ Scan + ENTER (time-saving) ◆ ENTER + Scan (efficient for continuous scanning) 	Scan + ENTER
Auto ENTER Character	<p>*Auto ENTER must be enabled.</p> <ul style="list-style-type: none"> ◆ None ◆ Carriage Return ◆ Tab ◆ Space ◆ Comma ◆ Semicolon 	Carriage Return
Prefix Code	0~10 characters	NULL
Suffix Code	0~10 characters	NULL
Include Cody Type	YES or NO	NO (Disabled)
Include Cody Length	YES or NO	NO (Disabled)
Scan Mode	<p>Refer to Appendix I Comparison of Scan Modes.</p> <ul style="list-style-type: none"> ◆ Auto Off ◆ Continuous ◆ Auto Power Off ◆ Alternate ◆ Momentary ◆ Repeat ◆ Laser ◆ Test ◆ Aiming 	Laser mode
Barcode Decode Timeout	1~255 (sec.)	3 seconds
Barcode Read Redundancy	<p>Select a desired level of reading (decoding) security. Comprise some speed for getting more security when necessary. For example, if “None” is selected, it only requires one successful decoding to make the reading valid. If “Three times” is selected, it needs to successfully decode three more times to make the reading valid.</p> <ul style="list-style-type: none"> ◆ None 	None

	<ul style="list-style-type: none">◆ One time◆ Two times◆ Three times	
Negative Barcode	Normally, barcodes are printed with the color of the bars darker than that of the spaces. For negative barcodes, they are printed oppositely just like negative films. That is, the spaces of the negative barcodes are printed with the color darker than that of the bars. <ul style="list-style-type: none">◆ YES or NO	NO (Disabled)
RFID Settings will be displayed if the RFID reader is installed!		
Check reader status when start session	When running the program, it will take a few seconds to check status of the reader, barcode reader or RFID reader, before starting the session. <ul style="list-style-type: none">◆ YES or NO	YES (Enabled)

1D tab: CCD / Laser

Code 39	Supported on CCD / Laser	Default
	Enabled or Disabled	Enabled
Transmit Start / Stop	When enabled, the start / stop characters will be included in the data being transmitted.	OFF (Disabled)
Verify Checksum	When enabled, the checksum verification will be performed in decoding. If the checksum is incorrect, data will be rejected.	OFF (Disabled)
Transmit Checksum	The checksum character is included in the data being transmitted.	ON (Enabled)
Code 39 Full ASCII	When enabled, Code 39 Full ASCII will be supported instead. All the alphanumeric and special characters are included.	OFF (Disabled)

Italian Pharmacode	Supported on CCD / Laser	Default
	Enabled or Disabled	Disabled
Transmit Start / Stop	*Share the setting of Code 39.	
Transmit Checksum	The checksum character is included in the data being transmitted.	ON (Enabled)

French Pharmacode	Supported on CCD / Laser	Default
	Enabled or Disabled	Disabled
Transmit Start / Stop	*Share the setting of Code 39.	
Transmit Checksum	The checksum character is included in the data being transmitted.	ON (Enabled)

Industrial 25	Supported on CCD / Laser	Default
	Enabled or Disabled	Enabled
Start / Stop Character	The start / stop character of the selected barcode is included in the data being transmitted. <ul style="list-style-type: none"> ◆ Industrial 25 ◆ Interleaved 25 ◆ Matrix 25 	Industrial 25
Verify Checksum	When enabled, the checksum verification will be performed in decoding.	OFF (Disabled)

	If the checksum is incorrect, data will be rejected.	
Transmit Checksum	The checksum character is included in the data being transmitted.	ON (Enabled)
Length Qualification	The weak structure of some barcodes may cause a “short scan” error. This setting is used to prevent such an error by qualifying the allowable barcode length to ensure the correct barcode is read. <ul style="list-style-type: none"> ◆ Fixed Length (up to 2 lengths can be specified) ◆ Max / Min Length By default, the terminal will only accepts those barcodes with lengths that fall between the maximum and minimum lengths; otherwise, data will be rejected.	Max / Min Length
Maximum Length	0~127 characters	127
Minimum Length	0~127 characters	1

Interleaved 25	Supported on CCD / Laser	Default
	Enabled or Disabled	Enabled
Start / Stop Character	The start / stop character of the selected barcode is included in the data being transmitted. <ul style="list-style-type: none"> ◆ Industrial 25 ◆ Interleaved 25 ◆ Matrix 25 	Interleaved 25
Verify Checksum	When enabled, the checksum verification will be performed in decoding. If the checksum is incorrect, data will be rejected.	OFF (Disabled)
Transmit Checksum	The checksum character is included in the data being transmitted.	ON (Enabled)
Length Qualification	Refer to Industrial 25 above. <ul style="list-style-type: none"> ◆ Fixed Length ◆ Max / Min Length 	Max / Min Length
Maximum Length	0~127 characters	126
Minimum Length	0~127 characters	1

Matrix 25	Supported on CCD / Laser	Default
	Enabled or Disabled	Disabled
Start / Stop Character	The start / stop character of the selected barcode is included in the data being transmitted. <ul style="list-style-type: none"> ◆ Industrial 25 ◆ Interleaved 25 	Matrix 25

	<ul style="list-style-type: none"> ◆ Matrix 25 	
Verify Checksum	When enabled, the checksum verification will be performed in decoding. If the checksum is incorrect, data will be rejected.	OFF (Disabled)
Transmit Checksum	The checksum character is included in the data being transmitted.	ON (Enabled)
Length Qualification	Refer to Industrial 25 above. <ul style="list-style-type: none"> ◆ Fixed Length ◆ Max / Min Length 	Max / Min Length
Maximum Length	0~127 characters	127
Minimum Length	0~127 characters	1

Codabar	Supported on CCD / Laser	Default
	Enabled or Disabled	Enabled
Start / Stop Character	When enabled, the selected start / stop characters will be included in the data being transmitted. <ul style="list-style-type: none"> ◆ None ◆ abcd / abcd ◆ abcd / tn*e ◆ ABCD / ABCD ◆ ABCD / TN*E 	None

MSI	Supported on CCD / Laser	Default
	Enabled or Disabled	Disabled
Verify Checksum	Using the selected calculation method, the checksum verification is performed in decoding. If the checksum is incorrect, data will be rejected. <ul style="list-style-type: none"> ◆ Single Modulo 10 ◆ Double Modulo 10 ◆ Modulo 11 & 10 	Single Modulo 10
Transmit Checksum	Based on the selected conditions, the checksum characters are included in the data being transmitted. <ul style="list-style-type: none"> ◆ Last digit not transmitted ◆ Transmitted ◆ Last 2 digits not transmitted 	Transmitted
Length Qualification	Refer to Industrial 25 above. <ul style="list-style-type: none"> ◆ Fixed Length 	Max / Min Length

	◆ Max / Min Length	
Maximum Length	0~127 characters	127
Minimum Length	0~127 characters	0

Plessey	Supported on CCD / Laser	Default
	Enabled or Disabled	Disabled
Convert to UK Plessey	When enabled, each occurrence of the character “A” will be converted to “X”.	OFF (Disabled)
Transmit Checksum	The checksum characters (2 digits) are included in the data being transmitted.	ON (Enabled)

UPC-E	Supported on CCD / Laser	Default
	Enabled or Disabled	Enabled
Convert to UPC-A	When enabled, the UPC-E reading will be expanded into UPC-A. It will then be processed according to the settings of UPC-A.	OFF (Disabled)
Transmit System Number	When enabled, the system number will be included in the data being transmitted.	OFF (Disabled)
Transmit Checksum	The checksum character is included in the data being transmitted.	ON (Enabled)
Transmit Addon 2	When enabled, UPC-E Addon 2 can be decoded too.	OFF (Disabled)
Transmit Addon 5	When enabled, UPC-E Addon 5 can be decoded too.	OFF (Disabled)

EAN-8	Supported on CCD / Laser	Default
	Enabled or Disabled	Enabled
Convert to EAN-13	When enabled, the EAN-8 reading will be expanded into EAN-13. It will then be processed according to the settings of EAN-13.	OFF (Disabled)
Transmit Checksum	The checksum character is included in the data being transmitted.	ON (Enabled)
Transmit Addon 2	When enabled, EAN-8 Addon 2 can be decoded too.	OFF (Disabled)
Transmit Addon 5	When enabled, EAN-8 Addon 5 can be decoded too.	OFF (Disabled)

EAN-13	Supported on CCD / Laser	Default
	Enabled or Disabled	Enabled
Convert to ISBN	When enabled, the EAN-13 reading that starts with 978	OFF (Disabled)

	and 979 will be converted to ISBN.	
Convert to ISSN	When enabled, the EAN-13 reading that starts with 977 will be converted to ISSN.	OFF (Disabled)
Transmit Checksum	The checksum character is included in the data being transmitted.	ON (Enabled)
Transmit Addon 2	When enabled, EAN-13 Addon 2 can be decoded too.	OFF (Disabled)
Transmit Addon 5	When enabled, EAN-13 Addon 5 can be decoded too.	OFF (Disabled)

UPC-A	Supported on CCD / Laser	Default
	*Share the setting of EAN-13.	Enabled
Convert to EAN-13	The UPC-A reading will be expanded into EAN-13. It will then be processed according to the settings of EAN-13.	ON (Enabled)
Transmit System Number	The system number is included in the data being transmitted.	ON (Enabled)
Transmit Checksum	The checksum character is included in the data being transmitted.	ON (Enabled)
Transmit Addon 2	Share the setting of EAN-13	OFF (Disabled)
Transmit Addon 5	Share the setting of EAN-13	OFF (Disabled)

Telepen	Supported on CCD / Laser	Default
	Enabled or Disabled	Disabled
Telepen Type	<ul style="list-style-type: none"> ◆ Telepen Numeric is supported by default. ◆ Select AIM (Full ASCII) so that Telepen Full ASCII is supported. All the alphanumeric and special characters are included. 	Original (Numeric)

RSS-14	Supported on CCD / Laser	Default
	Enabled or Disabled	Disabled
Transmit Checksum	The checksum character is included in the data being transmitted.	ON (Enabled)
Transmit Application ID	The Application ID is included in the data being transmitted.	ON (Enabled)
Transmit Code ID	The Code ID (default to “]e0”) is included in the data being transmitted.	ON (Enabled)

RSS Limited	Supported on CCD / Laser	Default
	Enabled or Disabled	Disabled
Transmit Checksum	The checksum character is included in the data being transmitted.	ON (Enabled)
Transmit Application ID	The Application ID is included in the data being transmitted.	ON (Enabled)
Transmit Code ID	The Code ID (default to “]e0”) is included in the data being transmitted.	ON (Enabled)

RSS Expanded	Supported on CCD / Laser	Default
	Enabled or Disabled	Disabled
Transmit Code ID	The Code ID (default to “]e0”) is included in the data being transmitted.	ON (Enabled)

Code 93	Supported on CCD / Laser	Default
	Enabled or Disabled	Enabled

Code 128	Supported on CCD / Laser	Default
	Enabled or Disabled	Enabled

EAN-128	Supported on CCD / Laser	Default
	Share the setting of Code 128	Enabled
Transmit Code ID	When enabled, the Code ID (default to “]C1”) is included in the data being transmitted.	OFF (Disabled)

5.3.3 1D Reader - (Extra) Long Range Laser

General tab

Settings		Default
Active Device	The scan engine can be identified and toggled. Only one scan engine can be disabled at a time. <ul style="list-style-type: none"> ◆ 1D (Extra) Long Range Laser ◆ RFID 	Barcode Reader is always enabled if exists.
Good Read Beep	Mute, or Sound 1~9	Sound 2
Warning Beep	Mute, or Sound 1~9	Sound 9
Enable Vibrator	YES or NO	NO (Disabled)
Vibrator Duration	1~30 (sec.) *Vibrator must be enabled.	2 seconds
Data Output	There are three options for data output after decoding: <ul style="list-style-type: none"> ◆ Keyboard Emulation <ul style="list-style-type: none"> - Data is emulated as typed text and sent to the active Window. - Simply run your application or Pocket PC built-in program, such as Pocket Excel, to start with data collection. ◆ Windows Message <ul style="list-style-type: none"> - Data is encapsulated in a Windows message (WM_COPYDATA). - Retrieve the WM_COPYDATA message in your application. - The decoded data is passed to your application through the IParam parameter. ◆ Windows Event <ul style="list-style-type: none"> - Whenever the reader reads a barcode, a Windows event object named “DecodeEvent” will be signaled and the data will be stored in the Windows message queue. - Need to create an event object named “DecodeEvent” in your application so that the ReaderCfg utility can signal your application using this event object. - Call Windows API (ReadMsgQueue) in your application to retrieve the decoded data. <p>*Sample programs are provided for Windows Message & Event programming. For details, please contact CipherLab technical support team.</p>	Keyboard Emulation

Note: For the use of a different program rather than ReaderCfg, a dynamic-link library (DLL) file is provided.

Auto ENTER	<p>This function can spare you the trouble of pressing the [Enter] key on the terminal to confirm each scan. It will automatically add an ENTER character in front or to the end of one scan.</p> <ul style="list-style-type: none"> ◆ No ◆ Scan + ENTER (time-saving) ◆ ENTER + Scan (efficient for continuous scanning) 	Scan + ENTER
Auto ENTER Character	<p>*Auto ENTER must be enabled.</p> <ul style="list-style-type: none"> ◆ None ◆ Carriage Return ◆ Tab ◆ Space ◆ Comma ◆ Semicolon 	Carriage Return
Prefix Code	0~10 characters	NULL
Suffix Code	0~10 characters	NULL
Include Cody Type	YES or NO	NO (Disabled)
Include Cody Length	YES or NO	NO (Disabled)
Barcode Decode Timeout	1~99 (0.1 sec.)	3.0 seconds
Timeout When Decode Same Barcode	0~99 (0.1 sec.)	1.0 seconds
AIM Duration	0~99 (0.1 sec.)	0.0 seconds
RFID Settings will be displayed if the RFID reader is installed!		
Check reader status when start session	<p>When running the program, it will take a few seconds to check status of the reader, barcode reader or RFID reader, before starting the session.</p> <ul style="list-style-type: none"> ◆ YES or NO 	YES (Enabled)

1D tab: (Extra) Long Range Laser

UPC / EAN	Supported on (Extra) Long Range Laser	Default
Enable UPC-A	YES or NO	YES (Enabled)
Enable UPC-E0	YES or NO	YES (Enabled)
Enable UPC-E1	YES or NO	NO (Disabled)
Enable EAN-8	YES or NO	YES (Enabled)
Enable EAN-13	YES or NO	YES (Enabled)
Enable Bookland EAN	YES or NO *EAN-13 must be enabled!	NO (Disabled)
Decode Supplementary Digits (Addon 2 & 5)	When enabled, Addon 2 and Addon 5 of UPC /EAN families can be decoded too. <ul style="list-style-type: none"> ◆ Ignore Supplementals ◆ Only with Supplementals (Decode barcodes with Addons only.) ◆ Enable Supplementals (Decode barcodes with or without Addons.) 	Ignore Supplementals (Disabled)
Supplementary Redundancy	With “Enable Supplementals” is selected, it will autodiscriminate barcodes with or without supplementals. Select a desired level of reading (decoding) security. Comprise some speed for getting more security when necessary. By default, it requires ten more successful decoding to make the reading of supplementals (Addons) valid. <ul style="list-style-type: none"> ◆ 1~255 (decode times) 	10 times
Transmit UPC-A Check Digit	YES or NO	YES (Enabled)
Transmit UPC-E0 Check Digit	YES or NO	YES (Enabled)
Transmit UPC-E1 Check Digit	YES or NO	YES (Enabled)
UPC-A Preamble	By default, the selected UPC-A preamble is included in the data being transmitted. <ul style="list-style-type: none"> ◆ No Preamble ◆ System Character ◆ System Character & Country Code 	System Character
UPC-E0 Preamble	By default, the selected UPC-E0 preamble is included in the data being transmitted.	System Character
UPC-E1 Preamble	By default, the selected UPC-E1 preamble is included in the data being transmitted.	System Character

Convert UPC-E0 to UPC-A	When enabled, the UPC-E0 reading will be expanded into UPC-A. It will then be processed according to the settings of UPC-A.	NO (Disabled)
Convert UPC-E1 to UPC-A	When enabled, the UPC-E1 reading will be expanded into UPC-A. It will then be processed according to the settings of UPC-A.	NO (Disabled)
Convert EAN-8 to EAN-13	When enabled, the EAN-8 reading will be expanded into EAN-13. It will then be processed according to the settings of EAN-13.	NO (Disabled)
UCC Coupon Extended Code	When enabled, it will decode UPC-A barcodes starting with digit “5”, EAN-13 barcodes starting with digit “99”, and UPC-A/EAN-128 coupon codes. *UPC-A, EAN-13, and EAN-128 must be enabled! **Use “Supplemental Redundancy” to control auto-discrimination of the EAN-128 (right half) of a coupon code.	NO (Disabled)

Code 128	Supported on (Extra) Long Range Laser	Default
Enable Code 128	YES or NO	YES (Enabled)
Enable EAN-128	YES or NO	YES (Enabled)
Enable ISBT 128	YES or NO	YES (Enabled)

Code 39	Supported on (Extra) Long Range Laser	Default
Enable Code 39	YES or NO	YES (Enabled)
Enable Trioptic Code 39	YES or NO	NO (Disabled)
Convert Code 39 to Code 32	Code 32 is a variant of Code 39 used by the Italian pharmaceutical industry. When enabled, it will decode Code 32 barcodes as well. *Code 39 must be enabled!	NO (Disabled)
Code 32 Prefix	When enabled, the prefix character “A” will be added to all Code 32 barcodes. **“Convert Code 39 to Code 32” must be enabled!	NO (Disabled)
Select Discrete Length	The length of a barcode refers to the number of characters (i.e. human readable characters), including check digit(s) it contains. <ul style="list-style-type: none"> ◆ Any Length ◆ One Discrete Length ◆ Two Discrete Lengths 	Any Length

- ◆ Length within Range

For example, if “Length within Range” is selected, the terminal will only accept those barcodes with lengths that fall between the maximum and minimum lengths; otherwise, data will be rejected.

*If “Code 39 Full ASCII” is enabled, “Length within Range” or “Any Length” is the preferred option.

Verify Check Digit	When enabled, the checksum verification will be performed in decoding. If the checksum is incorrect, data will be rejected. *Only barcodes that include a Modulo 43 check digit are decoded. Enable this feature if the barcode contains a Modulo 43 check digit.	NO (Disabled)
Transmit Check Digit	When enabled, the check digit will be included in the data being transmitted. *By default, this feature (Not Transmit Check Digit) only works when “Verify Check Digit” is enabled first!	NO (Disabled)
Code 39 Full ASCII	When enabled, Code 39 Full ASCII will be supported instead. All the alphanumeric and special characters are included.	NO (Disabled)

Code 93	Supported on (Extra) Long Range Laser	Default
Enable Code 93	YES or NO	NO (Disabled)
Select Discrete Length	Refer to Code 39 above.	Any Length

Interleaved 25	Supported on (Extra) Long Range Laser	Default
Enable Interleaved 25	YES or NO	YES (Enabled)
Select Discrete Length	The length of a barcode refers to the number of characters (i.e. human readable characters), including check digit(s) it contains. The weak structure of some barcodes may cause a “short scan” error. To prevent this, select specific lengths: one or two discrete lengths <ul style="list-style-type: none"> ◆ Any Length ◆ One Discrete Length ◆ Two Discrete Lengths ◆ Length within Range For example, if “Length within Range” is selected, the	Any Length

	terminal will only accept those barcodes with lengths that fall between the maximum and minimum lengths; otherwise, data will be rejected.	
Verify Check Digit	When enabled, the checksum verification will be performed in decoding, based on the selected algorithm. If the checksum is incorrect, data will be rejected. <ul style="list-style-type: none"> ◆ Disable ◆ USS Check Digit (USS = Uniform Symbology Specification) ◆ OPCC Check Digit (OPCC = Optical Product Code Council) 	Disable
Transmit Check Digit	When enabled, the check digit will be included in the data being transmitted.	NO (Disabled)
Convert Interleaved 25 to EAN-13	When enabled, the Interleaved 25 reading will be expanded into EAN-13. It will then be processed according to the settings of EAN-13. *The barcode must have a leading zero and a valid EAN-13 check digit. ***"Verify Check Digit" must be disabled!	NO (Disabled)

Industrial 25	Supported on (Extra) Long Range Laser	Default
Enable Industrial 25	YES or NO	NO (Disabled)
Select Discrete Length	Refer to Interleaved 25 above.	Any Length

Codabar	Supported on (Extra) Long Range Laser	Default
Enable Codabar	YES or NO	NO (Disabled)
Select Discrete Length	Refer to Code 39 above.	Any Length
CLSI Editing	When enabled, it will strip start / stop characters and insert a space after the first, fifth, and tenth characters of a 14-character barcode. *This applies to 14-character barcodes only; barcode length does not include start and stop characters. If NOTIS is enabled, CLSI will override it.	NO (Disabled)
NOTIS Editing	When enabled, it will strip start / stop characters from a decoded barcode.	NO (Disabled)

MSI	Supported on (Extra) Long Range Laser	Default
Enable MSI	YES or NO	NO (Disabled)
Select Discrete Length	Refer to Interleaved 25 above.	Any Length
Check Digit	Select check digit(s) to transmit and verify: <ul style="list-style-type: none"> ◆ One MSI Check Digit ◆ Two MSI Check Digits 	One MSI Check Digit
Transmit Check Digit	When enabled, the check digit(s) will be included in the data being transmitted.	NO (Disabled)
Check Digit Algorithm	With MSI barcodes, one check digit is mandatory and always verified (using Single Modulo 10). The second check digit is optional. If two check digits are included, select a calculation method for the checksum verification to be performed in decoding. If the checksum is incorrect, data will be rejected. <ul style="list-style-type: none"> ◆ MOD 10 / MOD 11 ◆ MOD 10 / MOD 10 	MOD 10 / MOD 11

RSS-14	Supported on (Extra) Long Range Laser	Default
Enable RSS-14	YES or NO	YES (Enabled)
Enable RSS Limited	YES or NO	YES (Enabled)
Enable RSS Expanded	YES or NO	YES (Enabled)
Convert RSS to UPC/EAN	This only applies to RSS-14 and RSS Limited barcodes not decoded as part of a Composite barcode. <ol style="list-style-type: none"> (1) When enabled, the leading “010” will be stripped from these barcodes and a “0” will be encoded as the first digit; this will convert RSS barcodes to EAN-13. (2) For barcodes beginning with two or more zeros but not six zeros, this option will strip the leading “0010” and report the barcode as UPC-A. The UPC-A Preamble setting that transmits the system character and country code applies to such converted codes. *Neither the system character nor the check digit can be stripped. 	NO (Disabled)

5.3.4 2D Reader

General tab

Settings		Default
Active Device	The scan engine can be identified and toggled. Only one scan engine can be disabled at a time. <ul style="list-style-type: none"> ◆ 2D Reader ◆ RFID 	Barcode Reader is always enabled if exists.
Good Read Beep	Mute, or Sound 1~9	Sound 2
Warning Beep	Mute, or Sound 1~9	Sound 9
Enable Vibrator	YES or NO	NO (Disabled)
Vibrator Duration	1~30 (sec.) *Vibrator must be enabled.	2 seconds
Data Output	There are three options for data output after decoding: <ul style="list-style-type: none"> ◆ Keyboard Emulation <ul style="list-style-type: none"> - Data is emulated as typed text and sent to the active Window. - Simply run your application or Pocket PC built-in program, such as Pocket Excel, to start with data collection. ◆ Windows Message <ul style="list-style-type: none"> - Data is encapsulated in a Windows message (WM_COPYDATA). - Retrieve the WM_COPYDATA message in your application. - The decoded data is passed to your application through the IParam parameter. ◆ Windows Event <ul style="list-style-type: none"> - Whenever the reader reads a barcode, a Windows event object named "DecodeEvent" will be signaled and the data will be stored in the Windows message queue. - Need to create an event object named "DecodeEvent" in your application so that the ReaderCfg utility can signal your application using this event object. - Call Windows API (ReadMsgQueue) in your application to retrieve the decoded data. <p>*Sample programs are provided for Windows Message & Event programming. For details, please contact CipherLab technical support team.</p>	Keyboard Emulation

Note: For the use of a different program rather than ReaderCfg, a dynamic-link library (DLL) file is provided.

Auto ENTER	<p>This function can spare you the trouble of pressing the [Enter] key on the terminal to confirm each scan. It will automatically add an ENTER character in front or to the end of one scan.</p> <ul style="list-style-type: none"> ◆ No ◆ Scan + ENTER (time-saving) ◆ ENTER + Scan (efficient for continuous scanning) 	Scan + ENTER
Auto ENTER Character	<p>*Auto ENTER must be enabled.</p> <ul style="list-style-type: none"> ◆ None ◆ Carriage Return ◆ Tab ◆ Space ◆ Comma ◆ Semicolon 	Carriage Return
Prefix Code	0~10 characters	NULL
Suffix Code	0~10 characters	NULL
Include Cody Type	YES or NO	NO (Disabled)
Include Cody Length	YES or NO	NO (Disabled)
Barcode Decode Timeout	5~99 (0.1 sec.)	9.9 seconds
Timeout When Decode Same Barcode	0~99 (0.1 sec.)	0.6 seconds
Decoding Autoexposure	ON or OFF	ON
Decoding Illumination	ON or OFF	ON
Decoding Aiming Pattern	ON or OFF	ON
RFID Settings will be displayed if the RFID reader is installed!		
Check reader status when start session	<p>When running the program, it will take a few seconds to check status of the reader, barcode reader or RFID reader, before starting the session.</p> <ul style="list-style-type: none"> ◆ YES or NO 	YES (Enabled)

2D tab

UPC / EAN	Supported on 2D Reader	Default
Enable UPC-A	YES or NO	YES (Enabled)
Enable UPC-E0	YES or NO	YES (Enabled)
Enable UPC-E1	YES or NO	NO (Disabled)
Enable EAN-8	YES or NO	YES (Enabled)
Enable EAN-13	YES or NO	YES (Enabled)
Enable Bookland EAN	YES or NO *EAN-13 must be enabled!	NO (Disabled)
Decode Supplementary Digits (Addon 2 & 5)	When enabled, Addon 2 and Addon 5 of UPC /EAN families can be decoded too. <ul style="list-style-type: none"> ◆ Ignore Supplementals ◆ Only with Supplementals (Decode barcodes with Addons only.) ◆ Enable Supplementals (Decode barcodes with or without Addons.) 	Ignore Supplementals (Disabled)
Supplementary Redundancy	With “Enable Supplementals” is selected, it will autodiscriminate barcodes with or without supplementals. Select a desired level of reading (decoding) security. Comprise some speed for getting more security when necessary. By default, it requires ten more successful decoding to make the reading of supplementals (Addons) valid. <ul style="list-style-type: none"> ◆ 1~255 (decode times) 	10 times
Transmit UPC-A Check Digit	YES or NO	YES (Enabled)
Transmit UPC-E0 Check Digit	YES or NO	YES (Enabled)
Transmit UPC-E1 Check Digit	YES or NO	YES (Enabled)
UPC-A Preamble	By default, the selected UPC-A preamble is included in the data being transmitted. <ul style="list-style-type: none"> ◆ No Preamble ◆ System Character ◆ System Character & Country Code 	System Character
UPC-E0 Preamble	By default, the selected UPC-E0 preamble is included in the data being transmitted.	System Character
UPC-E1 Preamble	By default, the selected UPC-E1 preamble is included in the data being transmitted.	System Character
Convert UPC-E0 to	When enabled, the UPC-E0 reading will be expanded	NO (Disabled)

UPC-A	into UPC-A. It will then be processed according to the settings of UPC-A.	
Convert UPC-E1 to UPC-A	When enabled, the UPC-E1 reading will be expanded into UPC-A. It will then be processed according to the settings of UPC-A.	NO (Disabled)
Convert EAN-8 to EAN-13	When enabled, the EAN-8 reading will be expanded into EAN-13. It will then be processed according to the settings of EAN-13.	NO (Disabled)
UCC Coupon Extended Code	When enabled, it will decode UPC-A barcodes starting with digit “5”, EAN-13 barcodes starting with digit “99”, and UPC-A/EAN-128 coupon codes. *UPC-A, EAN-13, and EAN-128 must be enabled! **Use “Supplemental Redundancy” to control auto-discrimination of the EAN-128 (right half) of a coupon code.	NO (Disabled)
Linear UPC / EAN Decode	This applies to barcodes that contain two adjacent blocks, such as UPC-A, EAN-8, and EAN-13. When enabled, a barcode is transmitted only when both the left and right blocks are successfully decoded within one scan line. *Enable this option when barcodes are in proximity to each other.	NO (Disabled)

Code 128	Supported on 2D Reader	Default
Enable Code 128	YES or NO	YES (Enabled)
Enable EAN-128	YES or NO	YES (Enabled)
Enable ISBT 128	YES or NO	YES (Enabled)

Code 39	Supported on 2D Reader	Default
Enable Code 39	YES or NO	YES (Enabled)
Enable Trioptic Code 39	YES or NO	NO (Disabled)
Convert Code 39 to Code 32	Code 32 is a variant of Code 39 used by the Italian pharmaceutical industry. When enabled, it will decode Code 32 barcodes as well. *Code 39 must be enabled!	NO (Disabled)
Code 32 Prefix	When enabled, the prefix character “A” will be added to all Code 32 barcodes.	NO (Disabled)

	*"Convert Code 39 to Code 32" must be enabled!	
Select Discrete Length	<p>The length of a barcode refers to the number of characters (i.e. human readable characters), including check digit(s) it contains.</p> <ul style="list-style-type: none"> ◆ Any Length ◆ One Discrete Length ◆ Two Discrete Lengths ◆ Length within Range <p>For example, if "Length within Range" is selected, the terminal will only accepts those barcodes with lengths that fall between the maximum and minimum lengths; otherwise, data will be rejected.</p> <p>*If "Code 39 Full ASCII" is enabled, "Length within Range" or "Any Length" is the preferred option.</p>	Any Length
Verify Check Digit	<p>When enabled, the checksum verification will be performed in decoding.</p> <p>If the checksum is incorrect, data will be rejected.</p> <p>*Only barcodes that include a Modulo 43 check digit are decoded. Enable this feature if the barcode contains a Modulo 43 check digit.</p>	NO (Disabled)
Transmit Check Digit	<p>When enabled, the check digit will be included in the data being transmitted.</p> <p>*By default, this feature (Not Transmit Check Digit) only works when "Verify Check Digit" is enabled first!</p>	NO (Disabled)
Code 39 Full ASCII	<p>When enabled, Code 39 Full ASCII will be supported instead. All the alphanumeric and special characters are included.</p>	NO (Disabled)

Code 93	Supported on 2D Reader	Default
---------	------------------------	---------

Enable Code 93	YES or NO	NO (Disabled)
Select Discrete Length	Refer to Code 39 above.	Any Length

Code 11	Supported on 2D Reader	Default
---------	------------------------	---------

Enable Code 11	YES or NO	NO (Disabled)
Select Discrete Length	Refer to Code 39 above.	Any Length
Verify Check Digit	<p>When enabled, the checksum verification will be performed in decoding.</p> <p>If the checksum is incorrect, data will be rejected.</p>	Disable

- ◆ Disable
- ◆ One Check Digit
- ◆ Two Check Digits

Transmit Check Digit When enabled, the check digit will be included in the data being transmitted. NO (Disabled)

*By default, this feature (Not Transmit Check Digit) only works when “Verify Check Digit” is enabled first!

Interleaved 25	Supported on 2D Reader	Default
Enable Interleaved 25	YES or NO	YES (Enabled)
Select Discrete Length	<p>The length of a barcode refers to the number of characters (i.e. human readable characters), including check digit(s) it contains.</p> <p>The weak structure of some barcodes may cause a “short scan” error. To prevent this, select specific lengths: one or two discrete lengths</p> <ul style="list-style-type: none"> ◆ Any Length ◆ One Discrete Length ◆ Two Discrete Lengths ◆ Length within Range <p>For example, if “Length within Range” is selected, the terminal will only accepts those barcodes with lengths that fall between the maximum and minimum lengths; otherwise, data will be rejected.</p>	Any Length
Verify Check Digit	<p>When enabled, the checksum verification will be performed in decoding, based on the selected algorithm.</p> <p>If the checksum is incorrect, data will be rejected.</p> <ul style="list-style-type: none"> ◆ Disable ◆ USS Check Digit (USS = Uniform Symbology Specification) ◆ OPCC Check Digit (OPCC = Optical Product Code Council) 	Disable
Transmit Check Digit	When enabled, the check digit will be included in the data being transmitted.	NO (Disabled)
Convert Interleaved 25 to EAN-13	<p>When enabled, the Interleaved 25 reading will be expanded into EAN-13. It will then be processed according to the settings of EAN-13.</p> <p>*The barcode must have a leading zero and a valid EAN-13 check digit.</p>	NO (Disabled)

***“Verify Check Digit” must be disabled!

Industrial 25	Supported on 2D Reader	Default
Enable Industrial 25	YES or NO	NO (Disabled)
Select Discrete Length	Refer to Interleaved 25 above.	Any Length

Codabar	Supported on 2D Reader	Default
Enable Codabar	YES or NO	NO (Disabled)
Select Discrete Length	Refer to Code 39 above.	Any Length
CLSI Editing	When enabled, it will strip start / stop characters and insert a space after the first, fifth, and tenth characters of a 14-character barcode. *This applies to 14-character barcodes only; barcode length does not include start and stop characters. If NOTIS is enabled, CLSI will override it.	NO (Disabled)
NOTIS Editing	When enabled, it will strip start / stop characters from a decoded barcode.	NO (Disabled)

MSI	Supported on 2D Reader	Default
Enable MSI	YES or NO	NO (Disabled)
Select Discrete Length	Refer to Interleaved 25 above.	Any Length
Check Digit	Select check digit(s) to transmit and verify: <ul style="list-style-type: none"> ◆ One MSI Check Digit ◆ Two MSI Check Digits 	One MSI Check Digit
Transmit Check Digit	When enabled, the check digit(s) will be included in the data being transmitted.	NO (Disabled)
Check Digit Algorithm	With MSI barcodes, one check digit is mandatory and always verified (using Single Modulo 10). The second check digit is optional. If two check digits are included, select a calculation method for the checksum verification to be performed in decoding. If the checksum is incorrect, data will be rejected. <ul style="list-style-type: none"> ◆ MOD 10 / MOD 11 ◆ MOD 10 / MOD 10 	MOD 10 / MOD 11

Postal Codes	Supported on 2D Reader	Default
Enable US Postnet	YES or NO	YES (Enabled)
Enable US Planet	YES or NO	YES (Enabled)
Transmit US Check Digit	YES or NO	YES (Enabled)
Enable UK Postal	YES or NO	YES (Enabled)
Transmit UK Check Digit	YES or NO	YES (Enabled)
Enable Japan Postal	YES or NO	YES (Enabled)
Enable Australian Postal	YES or NO	YES (Enabled)
Enable Dutch Postal	YES or NO	YES (Enabled)

RSS-14	Supported on 2D Reader	Default
Enable RSS-14	YES or NO	YES (Enabled)
Enable RSS Limited	YES or NO	YES (Enabled)
Enable RSS Expanded	YES or NO	YES (Enabled)
Convert RSS to UPC/EAN	This only applies to RSS-14 and RSS Limited barcodes not decoded as part of a Composite barcode. (1) When enabled, the leading “010” will be stripped from these barcodes and a “0” will be encoded as the first digit; this will convert RSS barcodes to EAN-13. (2) For barcodes beginning with two or more zeros but not six zeros, this option will strip the leading “0010” and report the barcode as UPC-A. The UPC-A Preamble setting that transmits the system character and country code applies to such converted codes. *Neither the system character nor the check digit can be stripped.	NO (Disabled)

Composite Codes	Supported on 2D Reader	Default
Enable Composite CC-C	YES or NO	NO (Disabled)
Enable Composite CC-A/B	YES or NO	NO (Disabled)
Enable Composite	YES or NO	NO (Disabled)

TLC-39

Enable UPC Composite Mode	UPC barcodes can be “linked” with a 2D barcode during transmission as if they were one barcode. There are three options for these composite barcodes:	UPC Always Linked
	<ul style="list-style-type: none"> ◆ UPC Never Linked (to transmit UPC barcodes only, regardless of whether a 2D barcode is detected) ◆ UPC Always Linked (to transmit UPC barcodes and the 2D portion; if 2D is not present, it will not transmit UPC barcodes, i.e. CC-A/B or CC-C must be enabled!) ◆ Autodiscriminate UPC Composites (to transmit UPC barcodes, as well as the 2D portion if present) 	
Enable UCC/EAN Code 128 Emulation	YES or NO	NO (Disabled)

2D Symbolologies	Supported on 2D Reader	Default
Enable PDF417	YES or NO	YES (Enabled)
Enable MicroPDF417	YES or NO	NO (Disabled)
Enable Code 128 Emulation	YES or NO *MicroPDF417 must be enabled! If Code 128 Emulation is enabled, these MicroPDF417 barcodes are transmitted with one of the following prefixes: <ul style="list-style-type: none"> ◆]C1 if the first codeword is 903-907, 912, 914, 915 ◆]C2 if the first codeword is 908 or 909 ◆]C0 if the first codeword is 910 or 911 If disabled, they are transmitted with one of the following prefixes: <ul style="list-style-type: none"> ◆]L3 if the first codeword is 903-907, 912, 914, 915 ◆]L4 if the first codeword is 908 or 909 ◆]L5 if the first codeword is 910 or 911 	NO (Disabled)
Enable Data Matrix	YES or NO	YES (Enabled)
Enable MaxiCode	YES or NO	YES (Enabled)
Enable QR Code	YES or NO	YES (Enabled)

Macro PDF	Supported on 2D Reader	Default
Transmit / Decode Mode	There are three options for handling Macro PDF decoding:	Passthrough All Symbols

	<ul style="list-style-type: none"> ◆ Buffer All Symbols / Transmit Macro PDF When Complete (to transmit all decoded data from an entire Macro PDF sequence only when the entire sequence is scanned and decoded; if the decoded data exceeds the limit of 50 symbols, no transmission because the entire sequence was not scanned!) ◆ Transmit Any Symbol in Set / No Particular Order (to transmit data from each Macro PDF symbol as decoded, regardless of the sequence; when selecting this mode, enable Transmit Control Header below!) ◆ Passthrough All Symbols (to transmit and decode all Macro PDF symbols and perform no processing; in this mode, the host is responsible for detecting and parsing the Macro PDF sequences) 	
Transmit Control Header	<p>When enabled, it activates transmission of the control header, which contains the segment index and the file ID.</p> <p>For example, the field may be \92800000\725\120\343. The five digits after the \928 are the segment index (or block index), and \725\120\343 is the file ID.</p> <ul style="list-style-type: none"> ◆ Enable this when selecting “Transmit Any Symbol in Set / No Particular Order” above. ◆ Disable this when selecting “Buffer All Symbols / Transmit Macro PDF When Complete”. ◆ This has no effect when selecting “Passthrough All Symbols”. 	NO (Disabled)
Escape Characters	<p>When enabled, it uses the backslash “\” as an Escape character for systems that can process transmissions containing special data sequences.</p> <ul style="list-style-type: none"> ◆ None ◆ GLI Protocol (to format special data according to the Global Label Identifier protocol; this only affects the data portion of a Macro PDF symbol transmission; the Control Header, if enabled, is always sent with GLI formatting) 	None (Disabled)

5.3.5 RFID Reader

If you have RFID reader installed, click the General tab and its settings are available at the bottom of the list.

General tab

Settings		Default
Read UID of RFID tag	YES or NO	YES (Enabled)
Read data of RFID tag	YES or NO	NO (Disabled)
Use Delimiter to separate UID from data	YES or NO	NO (Disabled)
Delimiter	1 character	, (comma)
Start Position	0~127	0
Maximum Length	0~127	127
RFID Read Duration	1~5 (sec.)	3 seconds
Check reader status when start session	When running the program, it will take a few seconds to check status of the reader, barcode reader or RFID reader, before starting the session. ♦ YES or NO	YES (Enabled)

5.4 Inbox

You can send and receive e-mail by connecting to a POP3 or IMAP4 server. **Inbox** provides an e-mail service for each method you use.

In addition, you can synchronize the e-mail messages in **Inbox** with either Microsoft Outlook or Microsoft Exchange Server on your computer through the default ActiveSync mail service.

5.4.1 Create an E-mail Box

1. Double-tap the **Inbox** shortcut on the desktop.

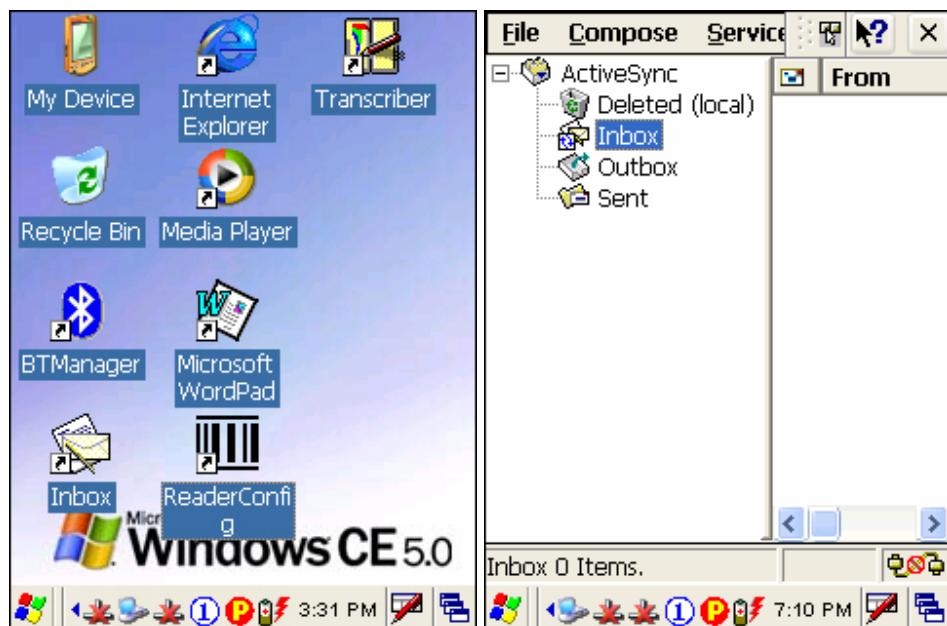

Tap and drag the toolbar handle to move it under the menu bar.



Toolbar handle

2. Select **Services > Options** from the menu bar.

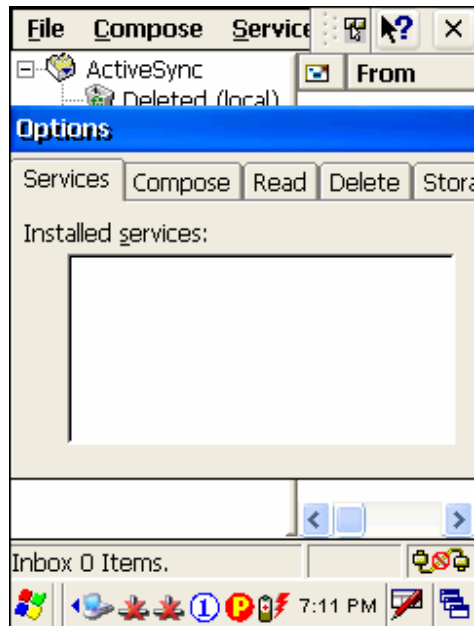

3. Tap and drag the dialog box to show the right edge. Tap [Add] to create an e-mail service.

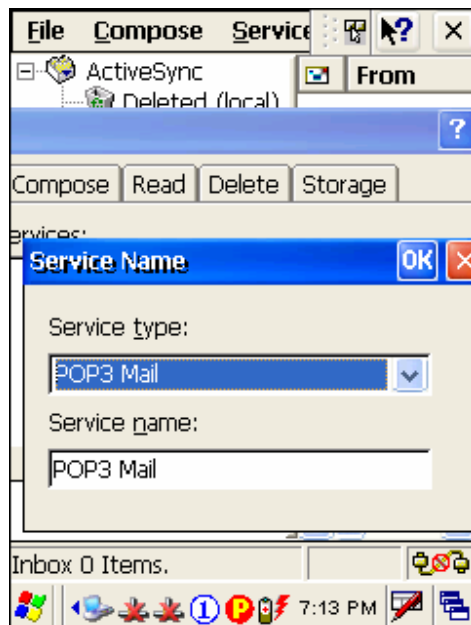



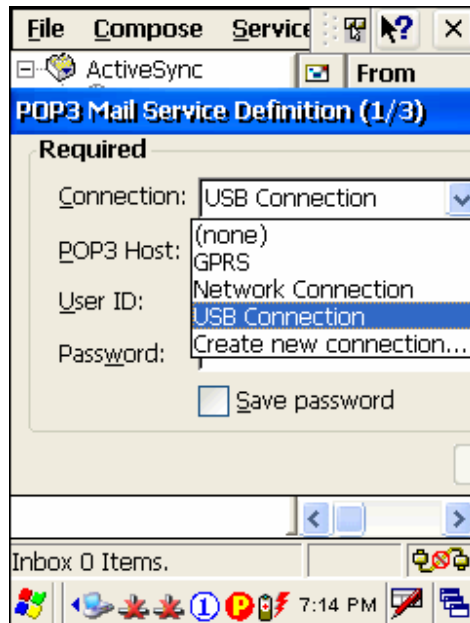





4. In the Service Name dialog box, select POP3 Mail or IMAP4 Mail for the service type. Change the name of e-mail service if necessary. Tap [OK].
5. Proceed with the POP3 or IMAP4 Mail Service Definition (from 1/3 to 3/3).



Connection	Description
Network Connection	Send and Receive e-mail through Ethernet, 802.11b or Bluetooth PAN connection.
USB Connection	Send and Receive e-mail through USB connection via the cradle.

6. After you successfully create an e-mail service, you may start using it now.

Toolbar

Buttons	Description	See Also
	Compose a new message	Compose > New Message
	Reply to sender	Compose > Reply to Sender
	Reply to all	Compose > Reply to All
	Forward this message	Compose > Forward
	Delete this message	File > Delete
	Synchronize folders (multiple mailboxes for IMAP4)	Services > Synchronize Folders
	Send and receive mail manually	Services > Send/Receive Mail
	Connect or disconnect	Services > Connect

- ◆ When connected, it will send and receive mail automatically.

5.4.2 Synchronize Inbox

When you seat the terminal in the cradle and connect it to your computer for the first time, ActiveSync 3.7.1 will guide you through setting up a partnership between the terminal and your computer. Refer to [ActiveSync with a Computer](#).

Select the check box of Inbox as shown below, and click [Settings] to configure it.

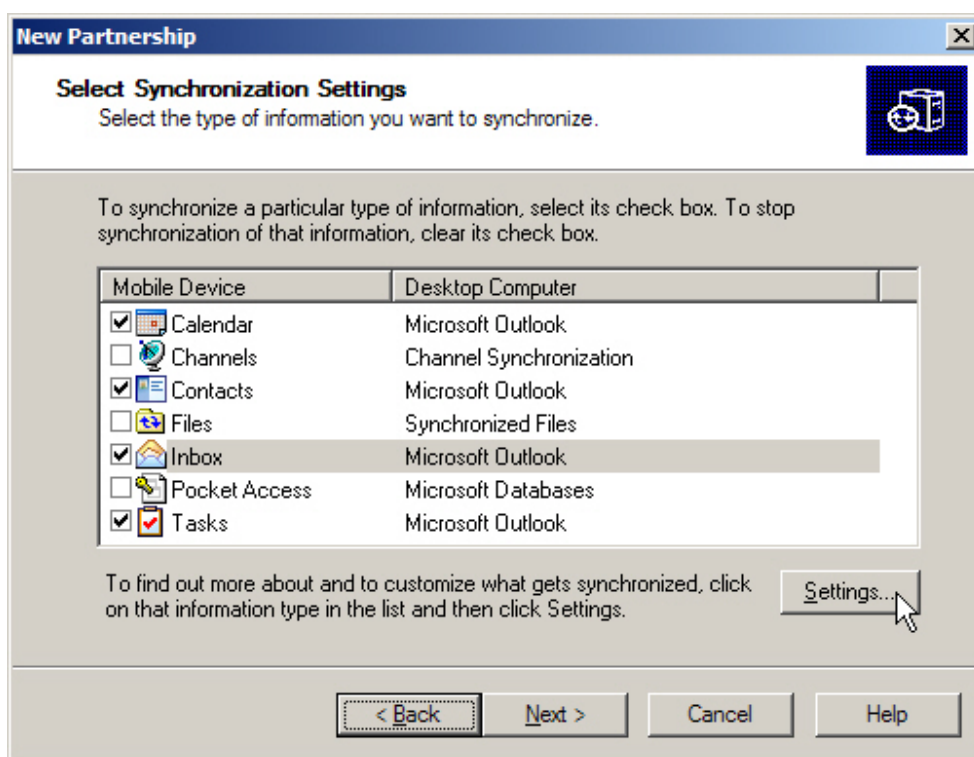

Note: ActiveSync 4.x does not support Inbox Synchronization. We recommend that you have ActiveSync 3.7.1 installed on your computer.

Specifications

General		
Power	Main:	Rechargeable 3.7 V, 4000 mAh Li-ion battery pack
	Backup:	Rechargeable 3.7 V, 110 mAh Lithium battery
	Adapter (cradle):	Input - AC 110/220 V Output - DC 6 V, 3.3 A
CPU	Intel PXA270 at 520 MHz	
Memory	ROM:	128 MB non-volatile NAND flash memory
	RAM:	128 MB on-board SDRAM memory
Operating System	Windows CE 5.0	
Programming	<ul style="list-style-type: none"> ◆ Visual Studio .NET 2003 with the Windows CE Utilities for Visual Studio .NET 2003 Add-on Pack ◆ eMbedded Visual C++ 4.0 SP4 ◆ a DLL file for reader configuration ◆ Windows-based Application Generator (AG) 	
Physical		
Enclosure Material:	Rubber & ABS plastic	
Dimensions:	230 mm (L) x 91 mm (W) x 63 mm (H)	
Weight:	Approx. 600 g (One battery pack included)	
Input Devices	Reader:	One scan engine (CCD/Laser/Long Range Laser/Extra Long Range Laser/2D), and/or the RFID reader
	Keypad:	27-key layout Rubber keys with LED backlight
Display	Type:	Color transfective TFT display with LED backlight Touch screen
	Size:	3.5 inches
	Resolution:	240 x 320 pixels
Indicators	LED:	Tri-color LED
	Speaker:	Low power transducer type, 1 KHz to 4 KHz
	Vibrator:	9000 ± 2000 RPM, Max. 50 dB

Communications	USB Client:	Peer-to-Peer connection via cradle (ActiveSync)
	USB Host:	For peripherals, such as a keyboard, mouse, storage card, etc.
	Ethernet:	10/100 Mbps via cradle
	WPAN / WLAN:	Bluetooth Class 2 IEEE 802.11b
Environmental		
Humidity	Operating:	5% to 90% non-condensing
	Storage:	5% to 95% non-condensing
Temperature	Operating:	-10 to 50 °C
	Storage:	-20 to 60 °C
Shock Resistance	1.5 m, 5 drops per 6 sides	
Splash/Dust Resistance	IP 64	
EMC Certification	FCC, CE, C-Tick	

APPENDIX I

Comparison of Scan Modes

For the following 1D scan engine, you can select a desired scan mode.

- CCD scan engine
- Laser scan engine

Scan Mode	ON				OFF			
	<i>Always</i>	<i>Press trigger once</i>	<i>Hold trigger</i>	<i>Press trigger twice</i>	<i>Release trigger</i>	<i>Press trigger once</i>	<i>Barcode being read</i>	<i>Time-out</i>
Continuous mode	✓							
Test mode	✓							
Repeat mode	✓							
Momentary mode			✓		✓			
Alternate mode		✓				✓		
Aiming mode				✓			✓	✓
Laser mode			✓		✓		✓	✓
Auto Off mode		✓					✓	✓
Auto Power Off mode		✓						✓

Continuous Mode

- ◆ The reader is always scanning, but only one decoding is allowed for the same barcode. That is, to read (i.e. scan and decode) the same barcode multiple times, the barcode has to be taken away and replaced for new scanning.
- ◆ Several modes have been developed based on this mode.

Test Mode

- ◆ The reader is always scanning for testing purpose.
- ◆ Comparing to the Continuous mode, it will decode repeatedly even with the same barcode without re-approaching.

Repeat Mode

This mode is most useful when the same barcode is to be read many times. When the scan trigger is pressed within one second after a successful reading, the same data will be re-transmitted without actually reading the barcode. Such re-transmission can be activated as many times as needed, as long as the time interval between each triggering does not exceed one second.

- ◆ The reader is always scanning.
- ◆ It will decode once for the same barcode and allow for re-transmission when triggering within one second.

Momentary Mode

- ◆ Hold down the scan trigger to start scanning.
- ◆ The scanning continues until the trigger is released.

Alternate Mode

- ◆ Press the scan trigger to start scanning.
- ◆ The scanning continues until the trigger is pressed again.

Aiming Mode

This mode best applies when two barcodes are printed too close to each other. It is necessary to take aim first to make sure the correct barcode will be scanned.

- ◆ Press the scan trigger to aim at a barcode. Within one second, press the trigger again to decode the barcode.
- ◆ The scanning continues until one of the events happens:
 - (1) A barcode is read.
 - (2) The preset timeout expires.

Note: The system global variable AIMING_TIMEOUT can be used to change the default one-second timeout interval for aiming. The unit for this variable is 5 ms.

Laser Mode

This mode is most often used on laser scanners.

- ◆ Hold down the scan trigger to start scanning.
- ◆ The scanning continues until one of the events happens:
 - (1) A barcode is read.
 - (2) The preset timeout expires.
 - (3) The trigger is released.

Auto Off Mode

This is the default mode.

- ◆ The reader will start to scan once the scan trigger is pressed.
- ◆ The scanning continues until one of the events happens:
 - (1) A barcode is read.
 - (2) The preset timeout expires.

Auto Power Off Mode

- ◆ The reader will start to scan once the scan trigger is pressed.
- ◆ The scanning continues until one of the events happens:
 - (1) The preset timeout expires.
- ◆ Comparing to the Auto Off mode, the reader continues to scan whenever there is a successful reading of barcode because its timeout period re-counts.

This equipment has been tested and found to comply with the limits for a Class B digital device, pursuant to part 15 of the FCC rules. These limits are designed to provide reasonable protection against harmful interference in a residential installation. This equipment generates, use and can radiate radio frequency energy and, if not installed and used in accordance with the instructions, may cause harmful interference to radio communications. However, there is no guarantee that interference will not occur in a particular installation. If this equipment does cause harmful interference to radio or television reception, which can be determined by turning the equipment off and on, the user is encouraged the interference by one or more of the following measures:

- Reorient or relocate the receiving antenna.
- Increase the separation between the equipment and receiver.
- Connect the equipment into an outlet on a circuit different from that to which the receiver is connected.
- Consult the dealer or an experienced radio/TV technician for help.

You are cautioned that changes or modification not expressly approved by the party responsible for compliance could void your authority to operate the equipment.

The device complies with Part 15 of the FCC Rules. Operation is subject to the following two conditions: (1) this device may not cause harmful interference and (2) this device must accept any interference received, including interference that may cause undesired operation.

This Transmitter has been demonstrated co-location compliance requirements with Bluetooth/ RFID modules. This transmitter must not be co-location or operating in conjunction with other antenna or transmitter.