



# FCC TEST REPORT (15.407)

**REPORT NO.:** RF130307C04C-1

**MODEL NO.:** 9200C

**FCC ID:** Q3N-9200C

**RECEIVED:** Mar. 07, 2013

**TESTED:** Aug. 01 ~ Aug. 10, 2013

**ISSUED:** Aug. 13, 2013

**APPLICANT:** CIPHERLAB CO., LTD

**ADDRESS:** 12F, 333 Dunhua S. Rd., Sec.2 Taipei, Taiwan 106

**ISSUED BY:** Bureau Veritas Consumer Products Services (H.K.)  
Ltd., Taoyuan Branch

**LAB ADDRESS:** No. 47, 14th Ling, Chia Pau Vil., Lin Kou Dist., New  
Taipei City, Taiwan, R.O.C.

**TEST LOCATION:** No. 19, Hwa Ya 2nd Rd, Wen Hwa Tsuen, Kwei  
Shan Hsiang, Taoyuan Hsien 333, Taiwan, R.O.C.

This report should not be used by the client to claim product certification, approval, or endorsement by TAF or any government agencies.



This report is for your exclusive use. Any copying or replication of this report to or for any other person or entity, or use of our name or trademark, is permitted only with our prior written permission. This report sets forth our findings solely with respect to the test samples identified herein. The results set forth in this report are not indicative or representative of the quality or characteristics of the lot from which a test sample was taken or any similar or identical product unless specifically and expressly noted. Our report includes all of the tests requested by you and the results thereof based upon the information that you provided to us. You have 60 days from date of issuance of this report to notify us of any material error or omission caused by our negligence, provided, however, that such notice shall be in writing and shall specifically address the issue you wish to raise. A failure to raise such issue within the prescribed time shall constitute your unqualified acceptance of the completeness of this report, the tests conducted and the correctness of the report contents. Unless specific mention, the uncertainty of measurement has been explicitly taken into account to declare the compliance or non-compliance to the specification.



# TABLE OF CONTENTS

RELEASE CONTROL RECORD .....	4
1. CERTIFICATION.....	5
2. SUMMARY OF TEST RESULTS .....	6
2.1 MEASUREMENT UNCERTAINTY .....	6
3. GENERAL INFORMATION.....	7
3.1 GENERAL DESCRIPTION OF EUT .....	7
3.2 DESCRIPTION OF TEST MODES.....	9
3.2.1 TEST MODE APPLICABILITY AND TESTED CHANNEL DETAIL.....	10
3.3 DUTY CYCLE OF TEST SIGNAL.....	12
3.4 DESCRIPTION OF SUPPORT UNITS .....	13
3.4.1 CONFIGURATION OF SYSTEM UNDER TEST .....	13
3.5 GENERAL DESCRIPTION OF APPLIED STANDARDS .....	13
4. TEST TYPES AND RESULTS .....	15
4.1 RADIATED EMISSION AND BANDEDGE MEASUREMENT .....	15
4.1.1 LIMITS OF RADIATED EMISSION AND BANDEDGE MEASUREMENT.....	15
4.1.2 LIMITS OF UNWANTED EMISSION OUT OF THE RESTRICTED BANDS .....	15
4.1.3 TEST INSTRUMENTS.....	16
4.1.4 TEST PROCEDURES .....	17
4.1.5 DEVIATION FROM TEST STANDARD .....	17
4.1.6 TEST SETUP.....	18
4.1.7 EUT OPERATING CONDITION .....	18
4.1.8 TEST RESULTS .....	19
4.2 CONDUCTED EMISSION MEASUREMENT .....	39
4.2.1 LIMITS OF CONDUCTED EMISSION MEASUREMENT .....	39
4.2.2 TEST INSTRUMENTS.....	39
4.2.3 TEST PROCEDURES .....	40
4.2.4 DEVIATION FROM TEST STANDARD .....	40
4.2.5 TEST SETUP.....	40
4.2.6 EUT OPERATING CONDITIONS .....	40
4.2.7 TEST RESULTS .....	41
4.3 PEAK TRANSMIT POWER MEASUREMENT .....	45
4.3.1 LIMITS OF PEAK TRANSMIT POWER MEASUREMENT .....	45
4.3.2 TEST SETUP.....	45
4.3.3 TEST INSTRUMENTS.....	46
4.3.4 TEST PROCEDURE.....	46
4.3.5 DEVIATION FROM TEST STANDARD .....	46
4.3.6 EUT OPERATING CONDITIONS .....	46
4.3.7 TEST RESULTS .....	47
4.4 PEAK POWER SPECTRAL DENSITY MEASUREMENT .....	49
4.4.1 LIMITS OF PEAK POWER SPECTRAL DENSITY MEASUREMENT .....	49
4.4.2 TEST SETUP.....	49
4.4.3 TEST INSTRUMENTS.....	49
4.4.4 TEST PROCEDURES .....	49
4.4.5 DEVIATION FROM TEST STANDARD .....	49
4.4.6 EUT OPERATING CONDITIONS .....	49
4.4.7 TEST RESULTS .....	50
4.5 PEAK POWER EXCURSION MEASUREMENT .....	51



4.5.1	LIMITS OF PEAK POWER EXCURSION MEASUREMENT .....	51
4.5.2	TEST SETUP .....	51
4.5.3	TEST INSTRUMENTS.....	51
4.5.4	TEST PROCEDURE.....	51
4.5.5	DEVIATION FROM TEST STANDARD .....	51
4.5.6	EUT OPERATING CONDITIONS .....	51
4.5.7	TEST RESULTS .....	52
4.6	FREQUENCY STABILITY .....	53
4.6.1	LIMITS OF FREQUENCY STABILITY MEASUREMENT.....	53
4.6.2	TEST SETUP.....	53
4.6.3	TEST INSTRUMENTS.....	53
4.6.4	TEST PROCEDURE.....	54
4.6.5	DEVIATION FROM TEST STANDARD .....	54
4.6.6	EUT OPERATING CONDITION .....	54
4.6.7	TEST RESULTS .....	55
5.	PHOTOGRAPHS OF THE TEST CONFIGURATION .....	56
6.	INFORMATION ON THE TESTING LABORATORIES.....	57
7.	APPENDIX A - MODIFICATIONS RECORDERS FOR ENGINEERING CHANGES TO THE EUT BY THE LAB .....	58



A D T

## RELEASE CONTROL RECORD

ISSUE NO.	REASON FOR CHANGE	DATE ISSUED
RF130307C04C-1	Original release	Aug. 13, 2013



# 1. CERTIFICATION

**PRODUCT:** Mobile Computer  
**MODEL:** 9200C  
**BRAND:** CIPHERLAB  
**APPLICANT:** CIPHERLAB CO., LTD  
**TESTED:** Aug. 01 ~ Aug. 10, 2013  
**TEST SAMPLE:** ENGINEERING SAMPLE  
**STANDARDS:** **FCC Part 15, Subpart E (Section 15.407)**  
ANSI C63.10-2009

The above equipment (model: 9200C) has been tested by **Bureau Veritas Consumer Products Services (H.K.) Ltd., Taoyuan Branch**, and found compliance with the requirement of the above standards. The test record, data evaluation & Equipment Under Test (EUT) configurations represented herein are true and accurate accounts of the measurements of the sample's EMC characteristics under the conditions specified in this report.

**PREPARED BY :** Suntee Liu , **DATE :** Aug. 13, 2013  
Suntee Liu / Specialist

**APPROVED BY :** Ken Liu , **DATE :** Aug. 13, 2013  
Ken Liu / Senior Manager

## 2. SUMMARY OF TEST RESULTS

The EUT has been tested according to the following specifications:

APPLIED STANDARD: FCC PART 15, SUBPART E (SECTION 15.407)			
STANDARD SECTION	TEST TYPE	RESULT	REMARK
15.407(b)(6)	AC Power Conducted Emission	PASS	Meet the requirement of limit. Minimum passing margin is -5.70dB at 0.61094MHz.
15.407(b)(1/2/3) (b)(6)	Spurious Emissions	PASS	Meet the requirement of limit. Minimum passing margin is -3.8dB at 5725.00MHz.
15.407(a)(1/2)	Max Average Transmit Power	PASS	Meet the requirement of limit.
15.407(a)(6)	Peak Power Excursion	PASS	Meet the requirement of limit.
15.407(a)(1/2)	Peak Power Spectral Density	PASS	Meet the requirement of limit.
15.407(g)	Frequency Stability	PASS	Meet the requirement of limit.
15.203	Antenna Requirement	PASS	Antenna connector is solder not a standard connector.

### 2.1 MEASUREMENT UNCERTAINTY

Where relevant, the following measurement uncertainty levels have been estimated for tests performed on the EUT as specified in CISPR 16-4-2:

MEASUREMENT	FREQUENCY	UNCERTAINTY
Conducted emissions	9kHz~30MHz	2.44 dB
Radiated emissions	30MHz ~ 200MHz	2.93 dB
	200MHz ~1000MHz	2.95 dB
	1GHz ~ 18GHz	2.26 dB
	18GHz ~ 40GHz	1.94 dB

This uncertainty represents an expanded uncertainty expressed at approximately the 95% confidence level using a coverage factor of  $k = 2$ .

### 3. GENERAL INFORMATION

#### 3.1 GENERAL DESCRIPTION OF EUT

<b>EUT</b>	Mobile Computer
<b>MODEL NO.</b>	9200C
<b>POWER SUPPLY</b>	5Vdc (host equipment / adapter) 3.7Vdc (Battery)
<b>MODULATION TYPE</b>	64QAM, 16QAM, QPSK, BPSK
<b>MODULATION TECHNOLOGY</b>	OFDM
<b>TRANSFER RATE</b>	802.11a: 54/48/36/24/18/12/9/6Mbps 802.11n: up to 72.2Mbps
<b>OPERATING FREQUENCY</b>	5180 ~ 5240MHz, 5260 ~ 5320MHz, 5500 ~ 5700MHz
<b>NUMBER OF CHANNEL</b>	<b>5180 ~ 5240MHz:</b> 802.11a, 802.11n (20MHz): 4 <b>5260 ~ 5320MHz:</b> 802.11a, 802.11n (20MHz): 4 <b>5500 ~ 5700MHz:</b> 802.11a, 802.11n (20MHz): 8
<b>OUTPUT POWER</b>	<b>5180 ~ 5240MHz:</b> 17.298mW <b>5260 ~ 5320MHz:</b> 23.988mW <b>5500 ~ 5700MHz:</b> 42.073mW
<b>ANTENNA TYPE</b>	<b>5180 ~ 5240MHz:</b> PIFA antenna with 2.72dBi gain <b>5260 ~ 5320MHz:</b> PIFA antenna with 4.08dBi gain <b>5500 ~ 5700MHz:</b> PIFA antenna with 5.71dBi gain
<b>ANTENNA CONNECTOR</b>	Solder
<b>DATA CABLE</b>	NA
<b>I/O PORTS</b>	Refer to user's manual
<b>ACCESSORY DEVICES</b>	Adapter, Battery, EDA charger, Touch Pen

**NOTE:**

1. The EUT provides 1 completed transmitter and 1 receiver.

MODULATION MODE	TX FUNCTION
802.11b	1TX
802.11g	1TX
802.11a	1TX
802.11n (20MHz)	1TX

2. The EUT consumes power from the following battery & adapter.

Adapter	
Brand	ADAPTER TECH.
Model	STD-05040T
Input	100-240Vac, 47-63Hz, 0.58A MAX
Output	5Vdc, 4A, 20W MAX
Power Line	1.85m non-shielded AC cable without core 1.5m shielded DC cable with 1 core

Battery	
Brand	Cipherlab
Model	BA-0053A3
Rating	3.7Vdc, 3300mAh, 12.21Wh; min.: 3.6Vdc, max.: 4.2Vdc

3. The EUT uses the following accessory device:

EDA Charger	
Brand	Cipherlab
Model	SNP-9200-USB
Cable	1.9m shielded cable with 1 core

4. The above EUT information is declared by manufacturer and for more detailed features description, please refer to the manufacturer's specifications or user's manual.



### 3.2 DESCRIPTION OF TEST MODES

#### FOR 5180 ~ 5240MHz

4 channels are provided for 802.11a, 802.11n (20MHz):

CHANNEL	FREQUENCY	CHANNEL	FREQUENCY
36	5180 MHz	44	5220 MHz
40	5200 MHz	48	5240 MHz

#### FOR 5260 ~ 5320MHz

4 channels are provided for 802.11a, 802.11n (20MHz):

CHANNEL	FREQUENCY	CHANNEL	FREQUENCY
52	5260 MHz	60	5300 MHz
56	5280 MHz	64	5320 MHz

#### FOR 5500 ~ 5700MHz

8 channels are provided for 802.11a, 802.11n (20MHz):

CHANNEL	FREQUENCY	CHANNEL	FREQUENCY
100	5500 MHz	116	5580 MHz
104	5520 MHz	132	5660 MHz
108	5540 MHz	136	5680 MHz
112	5560 MHz	140	5700 MHz

### 3.2.1 TEST MODE APPLICABILITY AND TESTED CHANNEL DETAIL

EUT CONFIGURE MODE	APPLICABLE TO				DESCRIPTION
	RE $\geq$ 1G	RE<1G	PLC	APCM	
-	√	√	√	√	-

Where **RE $\geq$ 1G**: Radiated Emission above 1GHz **RE<1G**: Radiated Emission below 1GHz  
**PLC**: Power Line Conducted Emission **APCM**: Antenna Port Conducted Measurement

**NOTE:** The EUT had been pre-tested on the positioned of each 3 axis. The worst case was found when positioned on **X-plane**.

#### **RADIATED EMISSION TEST (ABOVE 1GHz):**

- Pre-Scan has been conducted to determine the worst-case mode from all possible combinations between available modulations, data rates and antenna ports (if EUT with antenna diversity architecture).
- Following channel(s) was (were) selected for the final test as listed below.

EUT CONFIGURE MODE	MODE	FREQ. BAND (MHz)	AVAILABLE CHANNEL	TESTED CHANNEL	MODULATION TECHNOLOGY	MODULATION TYPE	DATA RATE (Mbps)
-	802.11a	5180-5240	36 to 48	36, 40, 48	OFDM	BPSK	6.0
-	802.11n (20MHz)		36 to 48	36, 40, 48	OFDM	BPSK	6.5
-	802.11a	5260-5320	52 to 64	52, 60, 64	OFDM	BPSK	6.0
-	802.11n (20MHz)		52 to 64	52, 60, 64	OFDM	BPSK	6.5
-	802.11a	5500-5700	100 to 140	100, 116, 140	OFDM	BPSK	6.0
-	802.11n (20MHz)		100 to 140	100, 116, 140	OFDM	BPSK	6.5

#### **RADIATED EMISSION TEST (BELOW 1GHz):**

- Pre-Scan has been conducted to determine the worst-case mode from all possible combinations between available modulations, data rates and antenna ports (if EUT with antenna diversity architecture).
- Following channel(s) was (were) selected for the final test as listed below.

EUT CONFIGURE MODE	MODE	FREQ. BAND (MHz)	AVAILABLE CHANNEL	TESTED CHANNEL	MODULATION TECHNOLOGY	MODULATION TYPE	DATA RATE (Mbps)
-	802.11a	5180-5320	36 to 64	64	OFDM	BPSK	6.0
-	802.11a	5500-5700	100 to 140	100	OFDM	BPSK	6.0

**POWER LINE CONDUCTED EMISSION TEST:**

- Pre-Scan has been conducted to determine the worst-case mode from all possible combinations between available modulations, data rates and antenna ports (if EUT with antenna diversity architecture).
- Following channel(s) was (were) selected for the final test as listed below.

EUT CONFIGURE MODE	MODE	FREQ. BAND (MHz)	AVAILABLE CHANNEL	TESTED CHANNEL	MODULATION TECHNOLOGY	MODULATION TYPE	DATA RATE (Mbps)
-	802.11a	5180-5320	36 to 64	64	OFDM	BPSK	6.0
-	802.11a	5500-5700	100 to 140	100	OFDM	BPSK	6.0

**ANTENNA PORT CONDUCTED MEASUREMENT:**

- This item includes all test value of each mode, but only includes spectrum plot of worst value of each mode.
- Pre-Scan has been conducted to determine the worst-case mode from all possible combinations between available modulations, data rates and antenna ports (if EUT with antenna diversity architecture).
- Following channel(s) was (were) selected for the final test as listed below.

EUT CONFIGURE MODE	MODE	FREQ. BAND (MHz)	AVAILABLE CHANNEL	TESTED CHANNEL	MODULATION TECHNOLOGY	MODULATION TYPE	DATA RATE (Mbps)
-	802.11a	5180-5240	36 to 48	36, 40, 48	OFDM	BPSK	6.0
-	802.11n (20MHz)		36 to 48	36, 40, 48	OFDM	BPSK	6.5
-	802.11a	5260-5320	52 to 64	52, 60, 64	OFDM	BPSK	6.0
-	802.11n (20MHz)		52 to 64	52, 60, 64	OFDM	BPSK	6.5
-	802.11a	5500-5700	100 to 140	100, 116, 140	OFDM	BPSK	6.0
-	802.11n (20MHz)		100 to 140	100, 116, 140	OFDM	BPSK	6.5

**TEST CONDITION:**

APPLICABLE TO	ENVIRONMENTAL CONDITIONS	INPUT POWER	TESTED BY
RE≥1G	25deg. C, 65%RH	120Vac, 60Hz	Ted Chang
RE<1G	25deg. C, 65%RH	120Vac, 60Hz	Ted Chang
PLC	25deg. C, 65%RH	120Vac, 60Hz	Ted Chang
APCM	24deg. C, 64%RH	120Vac, 60Hz	Match Tsui

### 3.3 DUTY CYCLE OF TEST SIGNAL

If duty cycle is < 98%, duty factor shall be considered.

**802.11a:** Duty cycle =  $2.061/2.164 = 0.952$ , Duty factor =  $10 \cdot \log(1/0.952) = 0.21$

**802.11n (20MHz):** Duty cycle =  $1.920/2.020 = 0.950$ , Duty factor =  $10 \cdot \log(1/0.950) = 0.22$

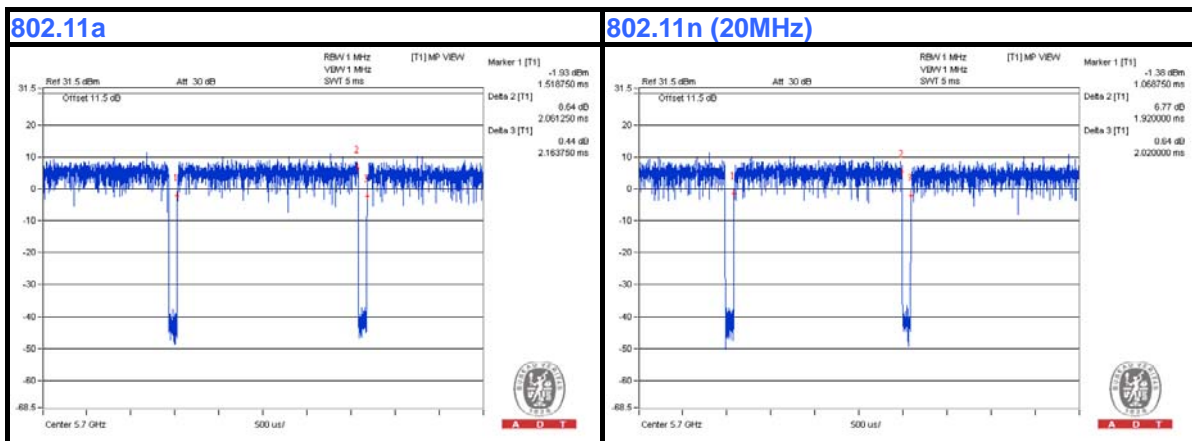

### 3.4 DESCRIPTION OF SUPPORT UNITS

The EUT has been tested as an independent unit together with other necessary accessories or support units. The following support units or accessories were used to form a representative test configuration during the tests.

NO.	PRODUCT	BRAND	MODEL NO.	SERIAL NO.	FCC ID
1	Notebook	DELL	E5410	1HC2XM1	FCC DoC Approved

NO.	SIGNAL CABLE DESCRIPTION OF THE ABOVE SUPPORT UNITS
1	NA

**NOTE:** All power cords of the above support units are non-shielded (1.8m).

#### 3.4.1 CONFIGURATION OF SYSTEM UNDER TEST

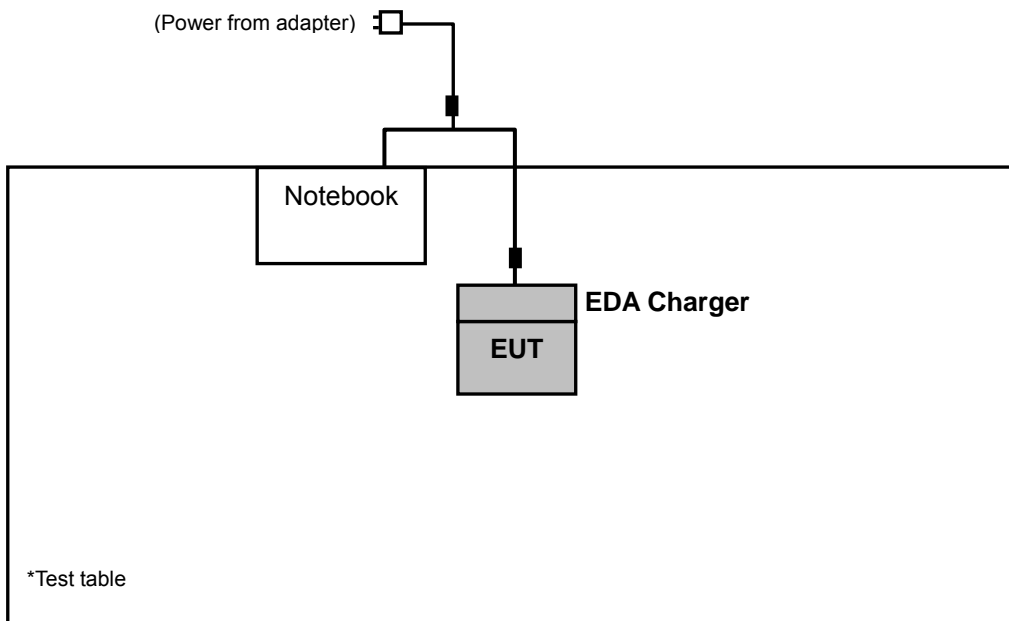

### **3.5 GENERAL DESCRIPTION OF APPLIED STANDARDS**

The EUT is a RF Product. According to the specifications of the manufacturer, it must comply with the requirements of the following standards:

**FCC Part 15, Subpart E (15.407)**

**789033 D01 General UNII Test Procedures v01 r02**

**ANSI C63.10-2009**

All test items have been performed and recorded as per the above standards.

**NOTE:** The EUT is also considered as a kind of computer peripheral, because the connection to computer is necessary for typical use. It has been verified to comply with the requirements of FCC Part 15, Subpart B, Class B (DoC). The test report has been issued separately.

## 4. TEST TYPES AND RESULTS

### 4.1 RADIATED EMISSION AND BANDEDGE MEASUREMENT

#### 4.1.1 LIMITS OF RADIATED EMISSION AND BANDEDGE MEASUREMENT

Radiated emissions which fall in the restricted bands must comply with the radiated emission limits specified as below table:

FREQUENCIES (MHz)	FIELD STRENGTH (microvolts/meter)	MEASUREMENT DISTANCE (meters)
0.009 ~ 0.490	2400/F(kHz)	300
0.490 ~ 1.705	24000/F(kHz)	30
1.705 ~ 30.0	30	30
30 ~ 88	100	3
88 ~ 216	150	3
216 ~ 960	200	3
Above 960	500	3

**NOTE:**

1. The lower limit shall apply at the transition frequencies.
2. Emission level (dBuV/m) = 20 log Emission level (uV/m).
3. For frequencies above 1000MHz, the field strength limits are based on average detector, however, the peak field strength of any emission shall not exceed the maximum permitted average limits, specified above by more than 20dB under any condition of modulation.

#### 4.1.2 LIMITS OF UNWANTED EMISSION OUT OF THE RESTRICTED BANDS

APPLICABLE TO	LIMIT	
√	FIELD STRENGTH AT 3m (dBμV/m)	
	PK	AV
	74	54
	EIRP LIMIT (dBm)	EQUIVALENT FIELD STRENGTH AT 3m (dBμV/m)
	PK	PK
	-27	68.3

**NOTE:** The following formula is used to convert the equipment isotropic radiated power (eirp) to field strength:

$$E = \frac{1000000\sqrt{30P}}{3} \mu\text{V/m, where P is the eirp (Watts).}$$

#### 4.1.3 TEST INSTRUMENTS

DESCRIPTION & MANUFACTURER	MODEL NO.	SERIAL NO.	DATE OF CALIBRATION	DUE DATE OF CALIBRATION
Test Receiver ROHDE & SCHWARZ	ESI7	838496/016	Dec. 25, 2012	Dec. 24, 2013
Spectrum Analyzer ROHDE & SCHWARZ	FSP40	100039	Jan. 31, 2013	Jan. 30, 2014
BILOG Antenna SCHWARZBECK	VULB9168	9168-160	Mar. 20, 2013	Mar. 19, 2014
HORN Antenna SCHWARZBECK	9120D	209	Sep. 03, 2012	Sep. 02, 2013
HORN Antenna SCHWARZBECK	BBHA 9170	148	Jul. 15, 2013	Jul. 14, 2014
Loop Antenna	HFH2-Z2	100070	Jan. 31, 2012	Jan. 30, 2014
Preamplifier Agilent	8447D	2944A10633	Oct. 25, 2012	Oct. 24, 2013
Preamplifier Agilent	8449B	3008A01964	Oct. 25, 2012	Oct. 24, 2013
RF signal cable HUBER+SUHNNER	SUCOFLEX 104	250723/4	Aug. 28, 2012	Aug. 27, 2013
RF signal cable HUBER+SUHNNER	SUCOFLEX 106	12738/6+309224/ 4	Aug. 28, 2012	Aug. 27, 2013
Software BV ADT	ADT_Radiated_ V7.6.15.9.4	NA	NA	NA
Antenna Tower inn-co GmbH	MA 4000	013303	NA	NA
Antenna Tower Controller inn-co GmbH	CO2000	017303	NA	NA
Turn Table BV ADT	TT100	TT93021703	NA	NA
Turn Table Controller BV ADT	SC100	SC93021703	NA	NA
26GHz ~ 40GHz Amplifier	EM26400	815221	Oct. 25, 2012	Oct. 24, 2013
High Speed Peak Power Meter	ML2495A	0842014	Apr. 25, 2013	Apr. 26, 2014
Power Sensor	MA2411B	0738404	Apr. 24, 2013	Apr. 23, 2014
WIT Standard Temperature And Humidity Chamber	TH-4S-C	W981030	Jun. 10, 2013	Jun. 09, 2014

- NOTE:**
1. The calibration interval of the above test instruments is 12 months and the calibrations are traceable to NML/ROC and NIST/USA.
  2. The calibration interval of the loop antenna is 24 months and the calibrations are traceable to NML/ROC and NIST/USA.
  3. The test was performed in HwaYa Chamber 3.
  4. The horn antenna and HP preamplifier (model: 8449B) are used only for the measurement of emission frequency above 1GHz if tested.
  5. The FCC Site Registration No. is 988962.
  6. The IC Site Registration No. is IC 7450F-3.



#### 4.1.4 TEST PROCEDURES

- a. The EUT was placed on the top of a rotating table 0.8 meters above the ground at a 3 meter semi-anechoic chamber. The table was rotated 360 degrees to determine the position of the highest radiation.
- b. The EUT was set 3 meters away from the interference-receiving antenna, which was mounted on the top of a variable-height antenna tower.
- c. The antenna is a broadband antenna, and its height is varied from one meter to four meters above the ground to determine the maximum value of the field strength. Both horizontal and vertical polarizations of the antenna are set to make the measurement.
- d. For each suspected emission, the EUT was arranged to its worst case and then the antenna was tuned to heights from 1 meter to 4 meters and the rotatable table was turned from 0 degrees to 360 degrees to find the maximum reading.
- e. The test-receiver system was set to Peak Detect Function and Specified Bandwidth with Maximum Hold Mode.
- f. If the emission level of the EUT in peak mode was 10dB lower than the limit specified, then testing could be stopped and the peak values of the EUT would be reported. Otherwise the emissions that did not have 10dB margin would be re-tested one by one using peak, quasi-peak or average method as specified and then reported in a data sheet.

**NOTE:**

1. The resolution bandwidth and video bandwidth of test receiver/spectrum analyzer is 120kHz for Quasi-peak detection at frequency below 1GHz.
2. The resolution bandwidth of test receiver/spectrum analyzer is 1MHz and the video bandwidth is 3MHz for Peak detection at frequency above 1GHz.
3. The resolution bandwidth of test receiver/spectrum analyzer is 1MHz and the video bandwidth is 1kHz (Duty cycle < 98%) or 10Hz (Duty cycle > 98%) for Average detection (AV) at frequency above 1GHz.
4. All modes of operation were investigated and the worst-case emissions are reported.

#### 4.1.5 DEVIATION FROM TEST STANDARD

No deviation.

#### 4.1.6 TEST SETUP

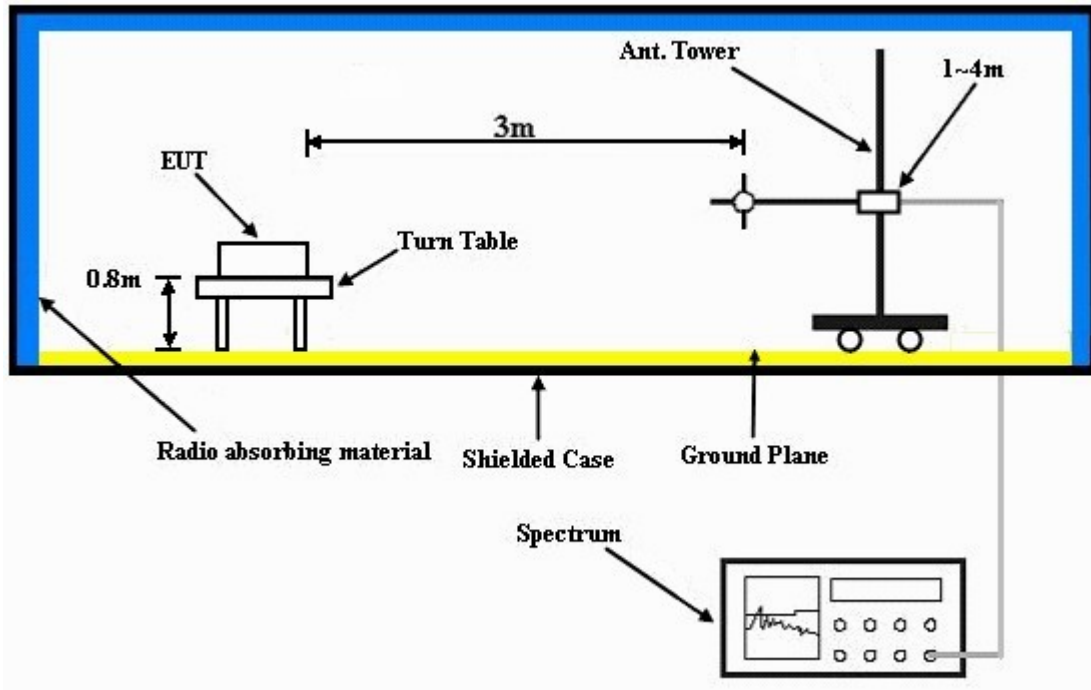

For the actual test configuration, please refer to the attached file (Test Setup Photo).

#### 4.1.7 EUT OPERATING CONDITION

- a. Connected the EUT with the notebook and placed on a testing table.
- b. The notebook ran a test program (provided by manufacturer) to enable EUT under transmission condition continuously at specific channel frequency.

#### 4.1.8 TEST RESULTS

##### 802.11a

EUT TEST CONDITION		MEASUREMENT DETAIL	
CHANNEL	Channel 36	FREQUENCY RANGE	1 ~ 40GHz
INPUT POWER (SYSTEM)	120Vac, 60Hz	DETECTOR FUNCTION	Peak (PK) Average (AV)
ENVIRONMENTAL CONDITIONS	25deg. C, 65%RH	TESTED BY	Ted Chang

ANTENNA POLARITY & TEST DISTANCE: HORIZONTAL AT 3 M								
NO.	FREQ. (MHz)	EMISSION LEVEL (dBuV/m)	LIMIT (dBuV/m)	MARGIN (dB)	ANTENNA HEIGHT (m)	TABLE ANGLE (Degree)	RAW VALUE (dBuV)	CORRECTION FACTOR (dB/m)
1	5150.00	57.4 PK	74.0	-16.6	1.48 H	8	53.60	3.80
2	5150.00	45.3 AV	54.0	-8.7	1.48 H	8	41.50	3.80
3	*5180.00	100.4 PK			1.48 H	6	62.60	37.80
4	*5180.00	89.2 AV			1.48 H	6	51.40	37.80
5	#10380.00	60.7 PK	74.0	-13.3	1.05 H	119	46.00	14.70
6	#10380.00	47.2 AV	54.0	-6.8	1.05 H	119	32.50	14.70
ANTENNA POLARITY & TEST DISTANCE: VERTICAL AT 3 M								
NO.	FREQ. (MHz)	EMISSION LEVEL (dBuV/m)	LIMIT (dBuV/m)	MARGIN (dB)	ANTENNA HEIGHT (m)	TABLE ANGLE (Degree)	RAW VALUE (dBuV)	CORRECTION FACTOR (dB/m)
1	5150.00	55.9 PK	74.0	-18.1	1.00 V	69	52.10	3.80
2	5150.00	43.4 AV	54.0	-10.6	1.00 V	69	39.60	3.80
3	*5180.00	101.8 PK			1.02 V	15	64.00	37.80
4	*5180.00	90.9 AV			1.02 V	15	53.10	37.80
5	#10360.00	55.1 PK	74.0	-18.9	1.06 V	21	40.60	14.50
6	#10360.00	45.0 AV	54.0	-9.0	1.06 V	21	30.50	14.50

#### REMARKS:

1. Emission Level(dBuV/m) = Raw Value(dBuV) + Correction Factor(dB/m)
2. Correction Factor(dB/m) = Antenna Factor(dB/m) + Cable Factor(dB) – Pre-Amplifier Factor (dB)
3. The other emission levels were very low against the limit.
4. Margin value = Emission Level – Limit value
5. " \* ": Fundamental frequency.
6. " # ": The radiated frequency is out of the restricted band.



A D T

EUT TEST CONDITION		MEASUREMENT DETAIL	
CHANNEL	Channel 40	FREQUENCY RANGE	1 ~ 40GHz
INPUT POWER (SYSTEM)	120Vac, 60Hz	DETECTOR FUNCTION	Peak (PK) Average (AV)
ENVIRONMENTAL CONDITIONS	25deg. C, 65%RH	TESTED BY	Ted Chang

ANTENNA POLARITY & TEST DISTANCE: HORIZONTAL AT 3 M								
NO.	FREQ. (MHz)	EMISSION LEVEL (dBuV/m)	LIMIT (dBuV/m)	MARGIN (dB)	ANTENNA HEIGHT (m)	TABLE ANGLE (Degree)	RAW VALUE (dBuV)	CORRECTION FACTOR (dB/m)
1	*5200.00	100.0 PK			1.00 H	32	62.20	37.80
2	*5200.00	88.8 AV			1.00 H	32	51.00	37.80
3	#10400.00	59.2 PK	74.0	-14.8	1.06 H	254	44.50	14.70
4	#10400.00	45.2 AV	54.0	-8.8	1.06 H	254	30.50	14.70

ANTENNA POLARITY & TEST DISTANCE: VERTICAL AT 3 M								
NO.	FREQ. (MHz)	EMISSION LEVEL (dBuV/m)	LIMIT (dBuV/m)	MARGIN (dB)	ANTENNA HEIGHT (m)	TABLE ANGLE (Degree)	RAW VALUE (dBuV)	CORRECTION FACTOR (dB/m)
1	*5200.00	102.1 PK			1.14 V	14	64.30	37.80
2	*5200.00	91.1 AV			1.14 V	14	53.30	37.80
3	#10400.00	62.3 PK	74.0	-11.7	1.62 V	22	47.60	14.70
4	#10400.00	48.2 AV	54.0	-5.8	1.62 V	22	33.50	14.70

**REMARKS:**

1. Emission Level(dBuV/m) = Raw Value(dBuV) + Correction Factor(dB/m)
2. Correction Factor(dB/m) = Antenna Factor(dB/m) + Cable Factor(dB)  
– Pre-Amplifier Factor (dB)
3. The other emission levels were very low against the limit.
4. Margin value = Emission Level – Limit value
5. " \* ": Fundamental frequency.
6. " # ": The radiated frequency is out of the restricted band.



A D T

EUT TEST CONDITION		MEASUREMENT DETAIL	
CHANNEL	Channel 48	FREQUENCY RANGE	1 ~ 40GHz
INPUT POWER (SYSTEM)	120Vac, 60Hz	DETECTOR FUNCTION	Peak (PK) Average (AV)
ENVIRONMENTAL CONDITIONS	25deg. C, 65%RH	TESTED BY	Ted Chang

ANTENNA POLARITY & TEST DISTANCE: HORIZONTAL AT 3 M								
NO.	FREQ. (MHz)	EMISSION LEVEL (dBuV/m)	LIMIT (dBuV/m)	MARGIN (dB)	ANTENNA HEIGHT (m)	TABLE ANGLE (Degree)	RAW VALUE (dBuV)	CORRECTION FACTOR (dB/m)
1	*5240.00	101.7 PK			1.03 H	45	63.90	37.80
2	*5240.00	91.6 AV			1.03 H	45	53.80	37.80
3	5350.00	57.5 PK	74.0	-16.5	1.03 H	45	53.20	4.30
4	5350.00	46.1 AV	54.0	-7.9	1.03 H	45	41.80	4.30
5	#10480.00	61.3 PK	74.0	-12.7	1.02 H	149	46.30	15.00
6	#10480.00	45.5 AV	54.0	-8.5	1.02 H	149	30.50	15.00
ANTENNA POLARITY & TEST DISTANCE: VERTICAL AT 3 M								
NO.	FREQ. (MHz)	EMISSION LEVEL (dBuV/m)	LIMIT (dBuV/m)	MARGIN (dB)	ANTENNA HEIGHT (m)	TABLE ANGLE (Degree)	RAW VALUE (dBuV)	CORRECTION FACTOR (dB/m)
1	*5240.00	102.1 PK			1.01 V	13	64.30	37.80
2	*5240.00	91.2 AV			1.01 V	13	53.40	37.80
3	5350.00	57.2 PK	74.0	-16.8	1.01 V	26	52.90	4.30
4	5350.00	46.2 AV	54.0	-7.8	1.01 V	26	41.90	4.30
5	#10480.00	62.8 PK	74.0	-11.2	1.09 V	247	47.80	15.00
6	#10480.00	48.6 AV	54.0	-5.4	1.09 V	247	33.60	15.00

**REMARKS:**

1. Emission Level(dBuV/m) = Raw Value(dBuV) + Correction Factor(dB/m)
2. Correction Factor(dB/m) = Antenna Factor(dB/m) + Cable Factor(dB) – Pre-Amplifier Factor (dB)
3. The other emission levels were very low against the limit.
4. Margin value = Emission Level – Limit value
5. " \* ": Fundamental frequency.
6. " # ": The radiated frequency is out of the restricted band.



EUT TEST CONDITION		MEASUREMENT DETAIL	
CHANNEL	Channel 52	FREQUENCY RANGE	1 ~ 40GHz
INPUT POWER (SYSTEM)	120Vac, 60Hz	DETECTOR FUNCTION	Peak (PK) Average (AV)
ENVIRONMENTAL CONDITIONS	25deg. C, 65%RH	TESTED BY	Martin Lee

ANTENNA POLARITY & TEST DISTANCE: HORIZONTAL AT 3 M								
NO.	FREQ. (MHz)	EMISSION LEVEL (dBuV/m)	LIMIT (dBuV/m)	MARGIN (dB)	ANTENNA HEIGHT (m)	TABLE ANGLE (Degree)	RAW VALUE (dBuV)	CORRECTION FACTOR (dB/m)
1	5150.00	57.6 PK	74.0	-16.4	1.07 H	5	53.80	3.80
2	5150.00	45.2 AV	54.0	-8.8	1.07 H	5	41.40	3.80
3	*5260.00	103.6 PK			1.07 H	6	65.70	37.90
4	*5260.00	92.7 AV			1.07 H	6	54.80	37.90
5	#10520.00	59.6 PK	74.0	-14.4	1.14 H	152	44.60	15.00
6	#10520.00	46.0 AV	54.0	-8.0	1.14 H	152	31.00	15.00
ANTENNA POLARITY & TEST DISTANCE: VERTICAL AT 3 M								
NO.	FREQ. (MHz)	EMISSION LEVEL (dBuV/m)	LIMIT (dBuV/m)	MARGIN (dB)	ANTENNA HEIGHT (m)	TABLE ANGLE (Degree)	RAW VALUE (dBuV)	CORRECTION FACTOR (dB/m)
1	5150.00	54.3 PK	74.0	-19.7	1.69 V	221	50.50	3.80
2	5150.00	44.0 AV	54.0	-10.0	1.69 V	221	40.20	3.80
3	*5260.00	101.4 PK			1.00 V	18	63.50	37.90
4	*5260.00	90.4 AV			1.00 V	18	52.50	37.90
5	#10520.00	63.0 PK	74.0	-11.0	1.36 V	228	48.00	15.00
6	#10520.00	48.5 AV	54.0	-5.5	1.36 V	228	33.50	15.00

**REMARKS:**

1. Emission Level(dBuV/m) = Raw Value(dBuV) + Correction Factor(dB/m)
2. Correction Factor(dB/m) = Antenna Factor(dB/m) + Cable Factor(dB) – Pre-Amplifier Factor (dB)
3. The other emission levels were very low against the limit.
4. Margin value = Emission Level – Limit value
5. " \* ": Fundamental frequency.
6. " # ": The radiated frequency is out of the restricted band.



A D T

EUT TEST CONDITION		MEASUREMENT DETAIL	
CHANNEL	Channel 60	FREQUENCY RANGE	1 ~ 40GHz
INPUT POWER (SYSTEM)	120Vac, 60Hz	DETECTOR FUNCTION	Peak (PK) Average (AV)
ENVIRONMENTAL CONDITIONS	25deg. C, 65%RH	TESTED BY	Martin Lee

ANTENNA POLARITY & TEST DISTANCE: HORIZONTAL AT 3 M								
NO.	FREQ. (MHz)	EMISSION LEVEL (dBuV/m)	LIMIT (dBuV/m)	MARGIN (dB)	ANTENNA HEIGHT (m)	TABLE ANGLE (Degree)	RAW VALUE (dBuV)	CORRECTION FACTOR (dB/m)
1	*5300.00	102.8 PK			1.00 H	46	64.90	37.90
2	*5300.00	92.3 AV			1.00 H	46	54.40	37.90
3	10600.00	62.1 PK	74.0	-11.9	1.09 H	57	46.90	15.20
4	10600.00	45.8 AV	54.0	-8.2	1.09 H	57	30.60	15.20
ANTENNA POLARITY & TEST DISTANCE: VERTICAL AT 3 M								
NO.	FREQ. (MHz)	EMISSION LEVEL (dBuV/m)	LIMIT (dBuV/m)	MARGIN (dB)	ANTENNA HEIGHT (m)	TABLE ANGLE (Degree)	RAW VALUE (dBuV)	CORRECTION FACTOR (dB/m)
1	*5300.00	102.4 PK			1.00 V	14	64.50	37.90
2	*5300.00	91.7 AV			1.00 V	14	53.80	37.90
3	10600.00	65.6 PK	74.0	-8.4	1.02 V	55	50.40	15.20
4	10600.00	49.7 AV	54.0	-4.3	1.02 V	55	34.50	15.20

**REMARKS:**

1. Emission Level(dBuV/m) = Raw Value(dBuV) + Correction Factor(dB/m)
2. Correction Factor(dB/m) = Antenna Factor(dB/m) + Cable Factor(dB)  
– Pre-Amplifier Factor (dB)
3. The other emission levels were very low against the limit.
4. Margin value = Emission Level – Limit value
5. " \* ": Fundamental frequency.



A D T

EUT TEST CONDITION		MEASUREMENT DETAIL	
CHANNEL	Channel 64	FREQUENCY RANGE	1 ~ 40GHz
INPUT POWER (SYSTEM)	120Vac, 60Hz	DETECTOR FUNCTION	Peak (PK) Average (AV)
ENVIRONMENTAL CONDITIONS	25deg. C, 65%RH	TESTED BY	Martin Lee

ANTENNA POLARITY & TEST DISTANCE: HORIZONTAL AT 3 M								
NO.	FREQ. (MHz)	EMISSION LEVEL (dBuV/m)	LIMIT (dBuV/m)	MARGIN (dB)	ANTENNA HEIGHT (m)	TABLE ANGLE (Degree)	RAW VALUE (dBuV)	CORRECTION FACTOR (dB/m)
1	*5320.00	105.0 PK			1.04 H	5	67.00	38.00
2	*5320.00	93.9 AV			1.04 H	5	55.90	38.00
3	5350.00	61.8 PK	74.0	-12.2	1.00 H	5	57.50	4.30
4	5350.00	47.0 AV	54.0	-7.0	1.00 H	5	42.70	4.30
5	10640.00	61.8 PK	74.0	-12.2	1.00 H	216	46.50	15.30
6	10640.00	46.5 AV	54.0	-7.5	1.00 H	216	31.20	15.30
ANTENNA POLARITY & TEST DISTANCE: VERTICAL AT 3 M								
NO.	FREQ. (MHz)	EMISSION LEVEL (dBuV/m)	LIMIT (dBuV/m)	MARGIN (dB)	ANTENNA HEIGHT (m)	TABLE ANGLE (Degree)	RAW VALUE (dBuV)	CORRECTION FACTOR (dB/m)
1	*5320.00	102.1 PK			1.00 V	16	64.10	38.00
2	*5320.00	91.9 AV			1.00 V	16	53.90	38.00
3	5350.00	58.9 PK	74.0	-15.1	1.02 V	16	54.60	4.30
4	5350.00	46.1 AV	54.0	-7.9	1.02 V	16	41.80	4.30
5	10640.00	64.9 PK	74.0	-9.1	1.05 V	348	49.60	15.30
6	10640.00	48.8 AV	54.0	-5.2	1.05 V	348	33.50	15.30

**REMARKS:**

1. Emission Level(dBuV/m) = Raw Value(dBuV) + Correction Factor(dB/m)
2. Correction Factor(dB/m) = Antenna Factor(dB/m) + Cable Factor(dB) – Pre-Amplifier Factor (dB)
3. The other emission levels were very low against the limit.
4. Margin value = Emission Level – Limit value
5. " \* ": Fundamental frequency.





A D T

EUT TEST CONDITION		MEASUREMENT DETAIL	
CHANNEL	Channel 100	FREQUENCY RANGE	1 ~ 40GHz
INPUT POWER (SYSTEM)	120Vac, 60Hz	DETECTOR FUNCTION	Peak (PK) Average (AV)
ENVIRONMENTAL CONDITIONS	25deg. C, 65%RH	TESTED BY	Martin Lee

ANTENNA POLARITY & TEST DISTANCE: HORIZONTAL AT 3 M								
NO.	FREQ. (MHz)	EMISSION LEVEL (dBuV/m)	LIMIT (dBuV/m)	MARGIN (dB)	ANTENNA HEIGHT (m)	TABLE ANGLE (Degree)	RAW VALUE (dBuV)	CORRECTION FACTOR (dB/m)
1	5460.00	57.0 PK	74.0	-17.0	1.10 H	60	52.50	4.50
2	5460.00	43.1 AV	54.0	-10.9	1.10 H	60	38.60	4.50
3	#5470.00	59.4 PK	74.0	-14.6	1.10 H	60	55.00	4.40
4	#5470.00	45.9 AV	54.0	-8.1	1.10 H	60	41.50	4.40
5	*5500.00	101.2 PK			1.00 H	44	62.90	38.30
6	*5500.00	92.0 AV			1.00 H	44	53.70	38.30
7	11000.00	58.7 PK	74.0	-15.3	1.25 H	98	42.70	16.00
8	11000.00	46.4 AV	54.0	-7.6	1.25 H	98	30.40	16.00
ANTENNA POLARITY & TEST DISTANCE: VERTICAL AT 3 M								
NO.	FREQ. (MHz)	EMISSION LEVEL (dBuV/m)	LIMIT (dBuV/m)	MARGIN (dB)	ANTENNA HEIGHT (m)	TABLE ANGLE (Degree)	RAW VALUE (dBuV)	CORRECTION FACTOR (dB/m)
1	5460.00	59.0 PK	74.0	-15.0	1.10 V	340	54.50	4.50
2	5460.00	43.6 AV	54.0	-10.4	1.10 V	340	39.10	4.50
3	#5470.00	62.5 PK	74.0	-11.5	1.10 V	340	58.10	4.40
4	#5470.00	45.5 AV	54.0	-8.5	1.10 V	340	41.10	4.40
5	*5500.00	104.8 PK			1.08 V	336	66.50	38.30
6	*5500.00	93.9 AV			1.08 V	336	55.60	38.30
7	11000.00	61.9 PK	74.0	-12.1	1.25 V	87	45.90	16.00
8	11000.00	49.4 AV	54.0	-4.6	1.25 V	87	33.40	16.00

**REMARKS:**

1. Emission Level(dBuV/m) = Raw Value(dBuV) + Correction Factor(dB/m)
2. Correction Factor(dB/m) = Antenna Factor(dB/m) + Cable Factor(dB)  
– Pre-Amplifier Factor (dB)
3. The other emission levels were very low against the limit.
4. Margin value = Emission Level – Limit value
5. " \* ": Fundamental frequency.
6. " # ": The radiated frequency is out of the restricted band.



A D T

EUT TEST CONDITION		MEASUREMENT DETAIL	
CHANNEL	Channel 116	FREQUENCY RANGE	1 ~ 40GHz
INPUT POWER (SYSTEM)	120Vac, 60Hz	DETECTOR FUNCTION	Peak (PK) Average (AV)
ENVIRONMENTAL CONDITIONS	25deg. C, 65%RH	TESTED BY	Martin Lee

ANTENNA POLARITY & TEST DISTANCE: HORIZONTAL AT 3 M								
NO.	FREQ. (MHz)	EMISSION LEVEL (dBuV/m)	LIMIT (dBuV/m)	MARGIN (dB)	ANTENNA HEIGHT (m)	TABLE ANGLE (Degree)	RAW VALUE (dBuV)	CORRECTION FACTOR (dB/m)
1	*5580.00	101.6 PK			1.37 H	83	63.20	38.40
2	*5580.00	91.9 AV			1.37 H	83	53.50	38.40
3	11160.00	58.7 PK	74.0	-15.3	1.32 H	87	42.70	16.00
4	11160.00	47.3 AV	54.0	-6.7	1.32 H	87	31.30	16.00
5	#16740.00	58.2 PK	74.0	-15.8	1.18 H	47	41.60	16.60
6	#16740.00	46.2 AV	54.0	-7.8	1.18 H	47	29.60	16.60
ANTENNA POLARITY & TEST DISTANCE: VERTICAL AT 3 M								
NO.	FREQ. (MHz)	EMISSION LEVEL (dBuV/m)	LIMIT (dBuV/m)	MARGIN (dB)	ANTENNA HEIGHT (m)	TABLE ANGLE (Degree)	RAW VALUE (dBuV)	CORRECTION FACTOR (dB/m)
1	*5580.00	104.7 PK			1.00 V	189	66.30	38.40
2	*5580.00	94.7 AV			1.00 V	189	56.30	38.40
3	11160.00	62.0 PK	74.0	-12.0	1.14 V	85	46.00	16.00
4	11160.00	48.7 AV	54.0	-5.3	1.14 V	85	32.70	16.00
5	#16740.00	61.3 PK	74.0	-12.7	1.08 V	95	44.70	16.60
6	#16740.00	48.3 AV	54.0	-5.7	1.08 V	95	31.70	16.60

**REMARKS:**

1. Emission Level(dBuV/m) = Raw Value(dBuV) + Correction Factor(dB/m)
2. Correction Factor(dB/m) = Antenna Factor(dB/m) + Cable Factor(dB) – Pre-Amplifier Factor (dB)
3. The other emission levels were very low against the limit.
4. Margin value = Emission Level – Limit value
5. " \* ": Fundamental frequency.
6. " # ": The radiated frequency is out of the restricted band.



A D T

EUT TEST CONDITION		MEASUREMENT DETAIL	
CHANNEL	Channel 140	FREQUENCY RANGE	1 ~ 40GHz
INPUT POWER (SYSTEM)	120Vac, 60Hz	DETECTOR FUNCTION	Peak (PK) Average (AV)
ENVIRONMENTAL CONDITIONS	25deg. C, 65%RH	TESTED BY	Martin Lee

ANTENNA POLARITY & TEST DISTANCE: HORIZONTAL AT 3 M								
NO.	FREQ. (MHz)	EMISSION LEVEL (dBuV/m)	LIMIT (dBuV/m)	MARGIN (dB)	ANTENNA HEIGHT (m)	TABLE ANGLE (Degree)	RAW VALUE (dBuV)	CORRECTION FACTOR (dB/m)
1	*5700.00	101.3 PK			1.00 H	1	62.70	38.60
2	*5700.00	91.5 AV			1.00 H	1	52.90	38.60
3	#5725.00	65.0 PK	74.0	-9.0	1.00 H	2	60.20	4.80
4	#5725.00	50.2 AV	54.0	-3.8	1.00 H	2	45.40	4.80
5	11400.00	58.9 PK	74.0	-15.1	1.02 H	85	43.00	15.90
6	11400.00	47.4 AV	54.0	-6.6	1.02 H	85	31.50	15.90
ANTENNA POLARITY & TEST DISTANCE: VERTICAL AT 3 M								
NO.	FREQ. (MHz)	EMISSION LEVEL (dBuV/m)	LIMIT (dBuV/m)	MARGIN (dB)	ANTENNA HEIGHT (m)	TABLE ANGLE (Degree)	RAW VALUE (dBuV)	CORRECTION FACTOR (dB/m)
1	*5700.00	104.3 PK			1.13 V	5	65.70	38.60
2	*5700.00	94.3 AV			1.13 V	5	55.70	38.60
3	#5725.00	65.6 PK	74.0	-8.4	1.25 V	295	60.80	4.80
4	#5725.00	48.8 AV	54.0	-5.2	1.25 V	295	44.00	4.80
5	11400.00	61.9 PK	74.0	-12.1	1.25 V	87	46.00	15.90
6	11400.00	49.4 AV	54.0	-4.6	1.25 V	87	33.50	15.90

**REMARKS:**

1. Emission Level(dBuV/m) = Raw Value(dBuV) + Correction Factor(dB/m)
2. Correction Factor(dB/m) = Antenna Factor(dB/m) + Cable Factor(dB) – Pre-Amplifier Factor (dB)
3. The other emission levels were very low against the limit.
4. Margin value = Emission Level – Limit value
5. " \* ": Fundamental frequency.
6. " # ": The radiated frequency is out of the restricted band.

802.11n (20MHz)

EUT TEST CONDITION		MEASUREMENT DETAIL	
CHANNEL	Channel 36	FREQUENCY RANGE	1 ~ 40GHz
INPUT POWER (SYSTEM)	120Vac, 60Hz	DETECTOR FUNCTION	Peak (PK) Average (AV)
ENVIRONMENTAL CONDITIONS	25deg. C, 65%RH	TESTED BY	Ted Chang

ANTENNA POLARITY & TEST DISTANCE: HORIZONTAL AT 3 M								
NO.	FREQ. (MHz)	EMISSION LEVEL (dBuV/m)	LIMIT (dBuV/m)	MARGIN (dB)	ANTENNA HEIGHT (m)	TABLE ANGLE (Degree)	RAW VALUE (dBuV)	CORRECTION FACTOR (dB/m)
1	5150.00	58.2 PK	74.0	-15.8	1.03 H	6	54.40	3.80
2	5150.00	45.2 AV	54.0	-8.8	1.03 H	6	41.40	3.80
3	*5180.00	98.8 PK			1.08 H	5	61.00	37.80
4	*5180.00	88.4 AV			1.08 H	5	50.60	37.80
5	#10360.00	60.0 PK	74.0	-14.0	1.97 H	207	45.50	14.50
6	#10360.00	45.6 AV	54.0	-8.4	1.97 H	207	31.10	14.50
ANTENNA POLARITY & TEST DISTANCE: VERTICAL AT 3 M								
NO.	FREQ. (MHz)	EMISSION LEVEL (dBuV/m)	LIMIT (dBuV/m)	MARGIN (dB)	ANTENNA HEIGHT (m)	TABLE ANGLE (Degree)	RAW VALUE (dBuV)	CORRECTION FACTOR (dB/m)
1	5150.00	55.0 PK	74.0	-19.0	1.03 V	16	51.20	3.80
2	5150.00	44.5 AV	54.0	-9.5	1.03 V	16	40.70	3.80
3	*5180.00	99.6 PK			1.03 V	15	61.80	37.80
4	*5180.00	89.4 AV			1.03 V	15	51.60	37.80
5	#10360.00	63.4 PK	74.0	-10.6	1.07 V	184	48.90	14.50
6	#10360.00	48.0 AV	54.0	-6.0	1.07 V	184	33.50	14.50

**REMARKS:**

1. Emission Level(dBuV/m) = Raw Value(dBuV) + Correction Factor(dB/m)
2. Correction Factor(dB/m) = Antenna Factor(dB/m) + Cable Factor(dB) – Pre-Amplifier Factor (dB)
3. The other emission levels were very low against the limit.
4. Margin value = Emission Level – Limit value
5. " \* ": Fundamental frequency.
6. " # ": The radiated frequency is out of the restricted band.



A D T

EUT TEST CONDITION		MEASUREMENT DETAIL	
CHANNEL	Channel 40	FREQUENCY RANGE	1 ~ 40GHz
INPUT POWER (SYSTEM)	120Vac, 60Hz	DETECTOR FUNCTION	Peak (PK) Average (AV)
ENVIRONMENTAL CONDITIONS	25deg. C, 65%RH	TESTED BY	Ted Chang

ANTENNA POLARITY & TEST DISTANCE: HORIZONTAL AT 3 M								
NO.	FREQ. (MHz)	EMISSION LEVEL (dBuV/m)	LIMIT (dBuV/m)	MARGIN (dB)	ANTENNA HEIGHT (m)	TABLE ANGLE (Degree)	RAW VALUE (dBuV)	CORRECTION FACTOR (dB/m)
1	*5200.00	98.5 PK			1.00 H	45	60.70	37.80
2	*5200.00	88.1 AV			1.00 H	45	50.30	37.80
3	#10400.00	58.8 PK	74.0	-15.2	1.36 H	247	44.10	14.70
4	#10400.00	45.2 AV	54.0	-8.8	1.36 H	247	30.50	14.70
ANTENNA POLARITY & TEST DISTANCE: VERTICAL AT 3 M								
NO.	FREQ. (MHz)	EMISSION LEVEL (dBuV/m)	LIMIT (dBuV/m)	MARGIN (dB)	ANTENNA HEIGHT (m)	TABLE ANGLE (Degree)	RAW VALUE (dBuV)	CORRECTION FACTOR (dB/m)
1	*5200.00	100.1 PK			1.40 V	25	62.30	37.80
2	*5200.00	84.5 AV			1.40 V	25	46.70	37.80
3	#10400.00	61.8 PK	74.0	-12.2	1.06 V	304	47.10	14.70
4	#10400.00	47.8 AV	54.0	-6.2	1.06 V	304	33.10	14.70

**REMARKS:**

1. Emission Level(dBuV/m) = Raw Value(dBuV) + Correction Factor(dB/m)
2. Correction Factor(dB/m) = Antenna Factor(dB/m) + Cable Factor(dB)  
– Pre-Amplifier Factor (dB)
3. The other emission levels were very low against the limit.
4. Margin value = Emission Level – Limit value
5. " \* ": Fundamental frequency.
6. " # ": The radiated frequency is out of the restricted band.



A D T

EUT TEST CONDITION		MEASUREMENT DETAIL	
CHANNEL	Channel 48	FREQUENCY RANGE	1 ~ 40GHz
INPUT POWER (SYSTEM)	120Vac, 60Hz	DETECTOR FUNCTION	Peak (PK) Average (AV)
ENVIRONMENTAL CONDITIONS	25deg. C, 65%RH	TESTED BY	Ted Chang

ANTENNA POLARITY & TEST DISTANCE: HORIZONTAL AT 3 M								
NO.	FREQ. (MHz)	EMISSION LEVEL (dBuV/m)	LIMIT (dBuV/m)	MARGIN (dB)	ANTENNA HEIGHT (m)	TABLE ANGLE (Degree)	RAW VALUE (dBuV)	CORRECTION FACTOR (dB/m)
1	*5240.00	100.4 PK			1.05 H	63	62.60	37.80
2	*5240.00	91.1 AV			1.05 H	63	53.30	37.80
3	5350.00	57.1 PK	74.0	-16.9	1.03 H	24	52.80	4.30
4	5350.00	46.1 AV	54.0	-7.9	1.03 H	24	41.80	4.30
5	#10480.00	58.8 PK	74.0	-15.2	1.95 H	357	43.80	15.00
6	#10480.00	45.8 AV	54.0	-8.2	1.95 H	357	30.80	15.00
ANTENNA POLARITY & TEST DISTANCE: VERTICAL AT 3 M								
NO.	FREQ. (MHz)	EMISSION LEVEL (dBuV/m)	LIMIT (dBuV/m)	MARGIN (dB)	ANTENNA HEIGHT (m)	TABLE ANGLE (Degree)	RAW VALUE (dBuV)	CORRECTION FACTOR (dB/m)
1	*5240.00	100.7 PK			1.00 V	28	62.90	37.80
2	*5240.00	90.6 AV			1.00 V	28	52.80	37.80
3	5350.00	55.6 PK	74.0	-18.4	1.47 V	132	51.30	4.30
4	5350.00	45.1 AV	54.0	-8.9	1.47 V	132	40.80	4.30
5	#10480.00	62.8 PK	74.0	-11.2	1.55 V	164	47.80	15.00
6	#10480.00	48.7 AV	54.0	-5.3	1.55 V	164	33.70	15.00

**REMARKS:**

1. Emission Level(dBuV/m) = Raw Value(dBuV) + Correction Factor(dB/m)
2. Correction Factor(dB/m) = Antenna Factor(dB/m) + Cable Factor(dB) – Pre-Amplifier Factor (dB)
3. The other emission levels were very low against the limit.
4. Margin value = Emission Level – Limit value
5. " \* ": Fundamental frequency.
6. " # ": The radiated frequency is out of the restricted band.



A D T

EUT TEST CONDITION		MEASUREMENT DETAIL	
CHANNEL	Channel 52	FREQUENCY RANGE	1 ~ 40GHz
INPUT POWER (SYSTEM)	120Vac, 60Hz	DETECTOR FUNCTION	Peak (PK) Average (AV)
ENVIRONMENTAL CONDITIONS	24deg. C, 69%RH	TESTED BY	Ted Chang

ANTENNA POLARITY & TEST DISTANCE: HORIZONTAL AT 3 M								
NO.	FREQ. (MHz)	EMISSION LEVEL (dBuV/m)	LIMIT (dBuV/m)	MARGIN (dB)	ANTENNA HEIGHT (m)	TABLE ANGLE (Degree)	RAW VALUE (dBuV)	CORRECTION FACTOR (dB/m)
1	5150.00	57.4 PK	74.0	-16.6	1.02 H	307	53.60	3.80
2	5150.00	46.3 AV	54.0	-7.7	1.02 H	307	42.50	3.80
3	*5260.00	101.9 PK			1.00 H	308	64.00	37.90
4	*5260.00	91.4 AV			1.00 H	308	53.50	37.90
5	#10520.00	59.5 PK	74.0	-14.5	1.03 H	62	44.50	15.00
6	#10520.00	45.5 AV	54.0	-8.5	1.03 H	62	30.50	15.00
ANTENNA POLARITY & TEST DISTANCE: VERTICAL AT 3 M								
NO.	FREQ. (MHz)	EMISSION LEVEL (dBuV/m)	LIMIT (dBuV/m)	MARGIN (dB)	ANTENNA HEIGHT (m)	TABLE ANGLE (Degree)	RAW VALUE (dBuV)	CORRECTION FACTOR (dB/m)
1	5150.00	55.0 PK	74.0	-19.0	1.06 V	51	51.20	3.80
2	5150.00	43.3 AV	54.0	-10.7	1.06 V	51	39.50	3.80
3	*5260.00	100.2 PK			1.07 V	115	62.30	37.90
4	*5260.00	89.2 AV			1.07 V	115	51.30	37.90
5	#10520.00	64.5 PK	74.0	-9.5	1.07 V	159	49.50	15.00
6	#10520.00	48.6 AV	54.0	-5.4	1.07 V	159	33.60	15.00

**REMARKS:**

1. Emission Level(dBuV/m) = Raw Value(dBuV) + Correction Factor(dB/m)
2. Correction Factor(dB/m) = Antenna Factor(dB/m) + Cable Factor(dB) – Pre-Amplifier Factor (dB)
3. The other emission levels were very low against the limit.
4. Margin value = Emission Level – Limit value
5. " \* ": Fundamental frequency.
6. " # ": The radiated frequency is out of the restricted band.



A D T

EUT TEST CONDITION		MEASUREMENT DETAIL	
CHANNEL	Channel 60	FREQUENCY RANGE	1 ~ 40GHz
INPUT POWER (SYSTEM)	120Vac, 60Hz	DETECTOR FUNCTION	Peak (PK) Average (AV)
ENVIRONMENTAL CONDITIONS	24deg. C, 69%RH	TESTED BY	Ted Chang

ANTENNA POLARITY & TEST DISTANCE: HORIZONTAL AT 3 M								
NO.	FREQ. (MHz)	EMISSION LEVEL (dBuV/m)	LIMIT (dBuV/m)	MARGIN (dB)	ANTENNA HEIGHT (m)	TABLE ANGLE (Degree)	RAW VALUE (dBuV)	CORRECTION FACTOR (dB/m)
1	*5300.00	101.6 PK			1.20 H	260	63.70	37.90
2	*5300.00	91.1 AV			1.20 H	260	53.20	37.90
3	10600.00	59.8 PK	74.0	-14.2	1.57 H	354	44.60	15.20
4	10600.00	46.8 AV	54.0	-7.2	1.57 H	354	31.60	15.20
ANTENNA POLARITY & TEST DISTANCE: VERTICAL AT 3 M								
NO.	FREQ. (MHz)	EMISSION LEVEL (dBuV/m)	LIMIT (dBuV/m)	MARGIN (dB)	ANTENNA HEIGHT (m)	TABLE ANGLE (Degree)	RAW VALUE (dBuV)	CORRECTION FACTOR (dB/m)
1	*5300.00	101.2 PK			1.42 V	185	63.30	37.90
2	*5300.00	90.5 AV			1.42 V	185	52.60	37.90
3	10600.00	63.0 PK	74.0	-11.0	1.62 V	249	47.80	15.20
4	10600.00	48.9 AV	54.0	-5.1	1.62 V	249	33.70	15.20

**REMARKS:**

1. Emission Level(dBuV/m) = Raw Value(dBuV) + Correction Factor(dB/m)
2. Correction Factor(dB/m) = Antenna Factor(dB/m) + Cable Factor(dB)  
– Pre-Amplifier Factor (dB)
3. The other emission levels were very low against the limit.
4. Margin value = Emission Level – Limit value
5. " \* ": Fundamental frequency.





A D T

EUT TEST CONDITION		MEASUREMENT DETAIL	
CHANNEL	Channel 64	FREQUENCY RANGE	1 ~ 40GHz
INPUT POWER (SYSTEM)	120Vac, 60Hz	DETECTOR FUNCTION	Peak (PK) Average (AV)
ENVIRONMENTAL CONDITIONS	24deg. C, 69%RH	TESTED BY	Ted Chang

ANTENNA POLARITY & TEST DISTANCE: HORIZONTAL AT 3 M								
NO.	FREQ. (MHz)	EMISSION LEVEL (dBuV/m)	LIMIT (dBuV/m)	MARGIN (dB)	ANTENNA HEIGHT (m)	TABLE ANGLE (Degree)	RAW VALUE (dBuV)	CORRECTION FACTOR (dB/m)
1	*5320.00	103.8 PK			1.04 H	10	65.80	38.00
2	*5320.00	92.7 AV			1.04 H	10	54.70	38.00
3	5350.00	61.3 PK	74.0	-12.7	1.00 H	6	57.00	4.30
4	5350.00	46.8 AV	54.0	-7.2	1.00 H	6	42.50	4.30
5	10640.00	60.8 PK	74.0	-13.2	1.42 H	141	45.50	15.30
6	10640.00	45.8 AV	54.0	-8.2	1.42 H	141	30.50	15.30
ANTENNA POLARITY & TEST DISTANCE: VERTICAL AT 3 M								
NO.	FREQ. (MHz)	EMISSION LEVEL (dBuV/m)	LIMIT (dBuV/m)	MARGIN (dB)	ANTENNA HEIGHT (m)	TABLE ANGLE (Degree)	RAW VALUE (dBuV)	CORRECTION FACTOR (dB/m)
1	*5320.00	101.0 PK			1.00 V	19	63.00	38.00
2	*5320.00	90.8 AV			1.00 V	19	52.80	38.00
3	5350.00	58.5 PK	74.0	-15.5	1.00 V	20	54.20	4.30
4	5350.00	45.6 AV	54.0	-8.4	1.00 V	20	41.30	4.30
5	10640.00	65.8 PK	74.0	-8.2	1.00 V	215	50.50	15.30
6	10640.00	48.8 AV	54.0	-5.2	1.00 V	215	33.50	15.30

**REMARKS:**

1. Emission Level(dBuV/m) = Raw Value(dBuV) + Correction Factor(dB/m)
2. Correction Factor(dB/m) = Antenna Factor(dB/m) + Cable Factor(dB) – Pre-Amplifier Factor (dB)
3. The other emission levels were very low against the limit.
4. Margin value = Emission Level – Limit value
5. " \* ": Fundamental frequency.



A D T

EUT TEST CONDITION		MEASUREMENT DETAIL	
CHANNEL	Channel 100	FREQUENCY RANGE	1 ~ 40GHz
INPUT POWER (SYSTEM)	120Vac, 60Hz	DETECTOR FUNCTION	Peak (PK) Average (AV)
ENVIRONMENTAL CONDITIONS	24deg. C, 69%RH	TESTED BY	Ted Chang

ANTENNA POLARITY & TEST DISTANCE: HORIZONTAL AT 3 M								
NO.	FREQ. (MHz)	EMISSION LEVEL (dBuV/m)	LIMIT (dBuV/m)	MARGIN (dB)	ANTENNA HEIGHT (m)	TABLE ANGLE (Degree)	RAW VALUE (dBuV)	CORRECTION FACTOR (dB/m)
1	5460.00	57.0 PK	74.0	-17.0	1.23 H	78	52.50	4.50
2	5460.00	42.9 AV	54.0	-11.1	1.23 H	78	38.40	4.50
3	#5470.00	57.7 PK	74.0	-16.3	1.35 H	25	53.30	4.40
4	#5470.00	46.4 AV	54.0	-7.6	1.35 H	25	42.00	4.40
5	*5500.00	100.0 PK			1.39 H	77	61.70	38.30
6	*5500.00	90.2 AV			1.39 H	77	51.90	38.30
7	11000.00	58.6 PK	74.0	-15.4	1.14 H	103	42.60	16.00
8	11000.00	47.3 AV	54.0	-6.7	1.14 H	103	31.30	16.00
ANTENNA POLARITY & TEST DISTANCE: VERTICAL AT 3 M								
NO.	FREQ. (MHz)	EMISSION LEVEL (dBuV/m)	LIMIT (dBuV/m)	MARGIN (dB)	ANTENNA HEIGHT (m)	TABLE ANGLE (Degree)	RAW VALUE (dBuV)	CORRECTION FACTOR (dB/m)
1	5460.00	58.1 PK	74.0	-15.9	1.20 V	340	53.60	4.50
2	5460.00	43.1 AV	54.0	-10.9	1.20 V	340	38.60	4.50
3	#5470.00	61.2 PK	74.0	-12.8	1.20 V	340	56.80	4.40
4	#5470.00	45.5 AV	54.0	-8.5	1.20 V	340	41.10	4.40
5	*5500.00	102.7 PK			1.07 V	333	64.40	38.30
6	*5500.00	92.6 AV			1.07 V	333	54.30	38.30
7	11000.00	62.9 PK	74.0	-11.1	1.32 V	87	46.90	16.00
8	11000.00	49.6 AV	54.0	-4.4	1.32 V	87	33.60	16.00

**REMARKS:**

1. Emission Level(dBuV/m) = Raw Value(dBuV) + Correction Factor(dB/m)
2. Correction Factor(dB/m) = Antenna Factor(dB/m) + Cable Factor(dB) – Pre-Amplifier Factor (dB)
3. The other emission levels were very low against the limit.
4. Margin value = Emission Level – Limit value
5. " \* ": Fundamental frequency.
6. " # ": The radiated frequency is out of the restricted band.



A D T

EUT TEST CONDITION		MEASUREMENT DETAIL	
CHANNEL	Channel 116	FREQUENCY RANGE	1 ~ 40GHz
INPUT POWER (SYSTEM)	120Vac, 60Hz	DETECTOR FUNCTION	Peak (PK) Average (AV)
ENVIRONMENTAL CONDITIONS	24deg. C, 69%RH	TESTED BY	Ted Chang

ANTENNA POLARITY & TEST DISTANCE: HORIZONTAL AT 3 M								
NO.	FREQ. (MHz)	EMISSION LEVEL (dBuV/m)	LIMIT (dBuV/m)	MARGIN (dB)	ANTENNA HEIGHT (m)	TABLE ANGLE (Degree)	RAW VALUE (dBuV)	CORRECTION FACTOR (dB/m)
1	*5580.00	100.1 PK			1.66 H	79	61.70	38.40
2	*5580.00	90.9 AV			1.66 H	79	52.50	38.40
3	11160.00	57.5 PK	74.0	-16.5	1.08 H	55	41.50	16.00
4	11160.00	46.9 AV	54.0	-7.1	1.08 H	55	30.90	16.00
5	#16740.00	60.2 PK	74.0	-13.8	1.15 H	74	43.60	16.60
6	#16740.00	48.0 AV	54.0	-6.0	1.15 H	74	31.40	16.60
ANTENNA POLARITY & TEST DISTANCE: VERTICAL AT 3 M								
NO.	FREQ. (MHz)	EMISSION LEVEL (dBuV/m)	LIMIT (dBuV/m)	MARGIN (dB)	ANTENNA HEIGHT (m)	TABLE ANGLE (Degree)	RAW VALUE (dBuV)	CORRECTION FACTOR (dB/m)
1	*5580.00	102.1 PK			1.01 V	194	63.70	38.40
2	*5580.00	92.0 AV			1.01 V	194	53.60	38.40
3	11160.00	62.7 PK	74.0	-11.3	1.32 V	85	46.70	16.00
4	11160.00	50.0 AV	54.0	-4.0	1.32 V	85	34.00	16.00
5	#16740.00	62.3 PK	74.0	-11.7	1.14 V	75	45.70	16.60
6	#16740.00	49.6 AV	54.0	-4.4	1.14 V	75	33.00	16.60

**REMARKS:**

1. Emission Level(dBuV/m) = Raw Value(dBuV) + Correction Factor(dB/m)
2. Correction Factor(dB/m) = Antenna Factor(dB/m) + Cable Factor(dB) – Pre-Amplifier Factor (dB)
3. The other emission levels were very low against the limit.
4. Margin value = Emission Level – Limit value
5. " \* ": Fundamental frequency.
6. " # ": The radiated frequency is out of the restricted band.



A D T

EUT TEST CONDITION		MEASUREMENT DETAIL	
CHANNEL	Channel 140	FREQUENCY RANGE	1 ~ 40GHz
INPUT POWER (SYSTEM)	120Vac, 60Hz	DETECTOR FUNCTION	Peak (PK) Average (AV)
ENVIRONMENTAL CONDITIONS	24deg. C, 69%RH	TESTED BY	Ted Chang

ANTENNA POLARITY & TEST DISTANCE: HORIZONTAL AT 3 M								
NO.	FREQ. (MHz)	EMISSION LEVEL (dBuV/m)	LIMIT (dBuV/m)	MARGIN (dB)	ANTENNA HEIGHT (m)	TABLE ANGLE (Degree)	RAW VALUE (dBuV)	CORRECTION FACTOR (dB/m)
1	*5700.00	100.7 PK			1.08 H	360	62.10	38.60
2	*5700.00	90.7 AV			1.08 H	360	52.10	38.60
3	#5725.00	64.8 PK	74.0	-9.2	1.10 H	350	60.00	4.80
4	#5725.00	49.3 AV	54.0	-4.7	1.10 H	350	44.50	4.80
5	11400.00	57.9 PK	74.0	-16.1	1.15 H	74	42.00	15.90
6	11400.00	47.4 AV	54.0	-6.6	1.15 H	74	31.50	15.90
ANTENNA POLARITY & TEST DISTANCE: VERTICAL AT 3 M								
NO.	FREQ. (MHz)	EMISSION LEVEL (dBuV/m)	LIMIT (dBuV/m)	MARGIN (dB)	ANTENNA HEIGHT (m)	TABLE ANGLE (Degree)	RAW VALUE (dBuV)	CORRECTION FACTOR (dB/m)
1	*5700.00	102.6 PK			1.00 V	294	64.00	38.60
2	*5700.00	92.3 AV			1.00 V	294	53.70	38.60
3	#5725.00	65.7 PK	74.0	-8.3	1.10 V	310	60.90	4.80
4	#5725.00	49.9 AV	54.0	-4.1	1.10 V	310	45.10	4.80
5	11400.00	62.6 PK	74.0	-11.4	1.25 V	96	46.70	15.90
6	11400.00	49.3 AV	54.0	-4.7	1.25 V	96	33.40	15.90

**REMARKS:**

1. Emission Level(dBuV/m) = Raw Value(dBuV) + Correction Factor(dB/m)
2. Correction Factor(dB/m) = Antenna Factor(dB/m) + Cable Factor(dB) – Pre-Amplifier Factor (dB)
3. The other emission levels were very low against the limit.
4. Margin value = Emission Level – Limit value
5. " \* ": Fundamental frequency.
6. " # ": The radiated frequency is out of the restricted band.



A D T

**BELOW 1GHz WORST-CASE DATA : 802.11a**

EUT TEST CONDITION		MEASUREMENT DETAIL	
CHANNEL	Channel 64	FREQUENCY RANGE	Below 1000MHz
INPUT POWER (SYSTEM)	120Vac, 60Hz	DETECTOR FUNCTION	Quasi-Peak
ENVIRONMENTAL CONDITIONS	25deg. C, 65%RH	TESTED BY	Ted Chang

ANTENNA POLARITY & TEST DISTANCE: HORIZONTAL AT 3 M								
NO.	FREQ. (MHz)	EMISSION LEVEL (dBuV/m)	LIMIT (dBuV/m)	MARGIN (dB)	ANTENNA HEIGHT (m)	TABLE ANGLE (Degree)	RAW VALUE (dBuV)	CORRECTION FACTOR (dB/m)
1	57.12	26.4 QP	40.0	-13.6	1.50 H	16	41.00	-14.60
2	255.44	20.6 QP	46.0	-25.4	1.00 H	78	34.60	-14.00
3	319.60	29.0 QP	46.0	-17.0	1.50 H	120	40.80	-11.80
4	477.09	20.2 QP	46.0	-25.8	1.00 H	339	28.80	-8.60
5	624.85	24.0 QP	46.0	-22.0	1.99 H	274	29.40	-5.40
6	712.35	25.0 QP	46.0	-21.0	1.00 H	68	29.40	-4.40
ANTENNA POLARITY & TEST DISTANCE: VERTICAL AT 3 M								
NO.	FREQ. (MHz)	EMISSION LEVEL (dBuV/m)	LIMIT (dBuV/m)	MARGIN (dB)	ANTENNA HEIGHT (m)	TABLE ANGLE (Degree)	RAW VALUE (dBuV)	CORRECTION FACTOR (dB/m)
1	57.12	28.7 QP	40.0	-11.3	1.24 V	347	43.30	-14.60
2	132.95	18.1 QP	43.5	-25.4	1.00 V	338	33.10	-15.00
3	319.60	20.6 QP	46.0	-25.4	1.50 V	254	32.40	-11.80
4	455.70	21.3 QP	46.0	-24.7	1.00 V	97	30.30	-9.00
5	628.74	23.5 QP	46.0	-22.5	1.99 V	273	28.90	-5.40
6	737.62	24.5 QP	46.0	-21.5	1.00 V	97	28.20	-3.70

**REMARKS:**

1. Emission Level(dBuV/m) = Raw Value(dBuV) + Correction Factor(dB/m)
2. Correction Factor(dB/m) = Antenna Factor(dB/m) + Cable Factor(dB) – Pre-Amplifier Factor (dB)
3. The other emission levels were very low against the limit.
4. Margin value = Emission Level – Limit value



A D T

EUT TEST CONDITION		MEASUREMENT DETAIL	
CHANNEL	Channel 100	FREQUENCY RANGE	Below 1000MHz
INPUT POWER (SYSTEM)	120Vac, 60Hz	DETECTOR FUNCTION	Quasi-Peak
ENVIRONMENTAL CONDITIONS	25deg. C, 65%RH	TESTED BY	Ted Chang

ANTENNA POLARITY & TEST DISTANCE: HORIZONTAL AT 3 M								
NO.	FREQ. (MHz)	EMISSION LEVEL (dBuV/m)	LIMIT (dBuV/m)	MARGIN (dB)	ANTENNA HEIGHT (m)	TABLE ANGLE (Degree)	RAW VALUE (dBuV)	CORRECTION FACTOR (dB/m)
1	57.12	26.5 QP	40.0	-13.5	1.00 H	43	41.10	-14.60
2	162.11	23.4 QP	43.5	-20.1	1.99 H	294	36.90	-13.50
3	319.60	28.9 QP	46.0	-17.1	1.24 H	298	40.70	-11.80
4	422.65	18.7 QP	46.0	-27.3	1.00 H	1	28.60	-9.90
5	537.36	21.5 QP	46.0	-24.5	1.00 H	17	29.10	-7.60
6	650.13	24.3 QP	46.0	-21.7	1.50 H	57	29.40	-5.10
ANTENNA POLARITY & TEST DISTANCE: VERTICAL AT 3 M								
NO.	FREQ. (MHz)	EMISSION LEVEL (dBuV/m)	LIMIT (dBuV/m)	MARGIN (dB)	ANTENNA HEIGHT (m)	TABLE ANGLE (Degree)	RAW VALUE (dBuV)	CORRECTION FACTOR (dB/m)
1	57.12	28.3 QP	40.0	-11.7	1.24 V	287	42.90	-14.60
2	132.95	20.9 QP	43.5	-22.6	1.00 V	175	35.90	-15.00
3	193.22	15.4 QP	43.5	-28.1	1.00 V	282	32.00	-16.60
4	319.60	19.3 QP	46.0	-26.7	1.24 V	16	31.10	-11.80
5	537.36	24.0 QP	46.0	-22.0	1.00 V	177	31.60	-7.60
6	620.96	24.5 QP	46.0	-21.5	1.50 V	169	30.00	-5.50

**REMARKS:**

1. Emission Level(dBuV/m) = Raw Value(dBuV) + Correction Factor(dB/m)
2. Correction Factor(dB/m) = Antenna Factor(dB/m) + Cable Factor(dB) – Pre-Amplifier Factor (dB)
3. The other emission levels were very low against the limit.
4. Margin value = Emission Level – Limit value

## 4.2 CONDUCTED EMISSION MEASUREMENT

### 4.2.1 LIMITS OF CONDUCTED EMISSION MEASUREMENT

FREQUENCY OF EMISSION (MHz)	CONDUCTED LIMIT (dB $\mu$ V)	
	Quasi-peak	Average
0.15 ~ 0.5	66 to 56	56 to 46
0.5 ~ 5	56	46
5 ~ 30	60	50

- NOTE:**
1. The lower limit shall apply at the transition frequencies.
  2. The limit decreases in line with the logarithm of the frequency in the range of 0.15 to 0.50MHz.
  3. All emanations from a class A/B digital device or system, including any network of conductors and apparatus connected thereto, shall not exceed the level of field strengths specified above.

### 4.2.2 TEST INSTRUMENTS

DESCRIPTION & MANUFACTURER	MODEL NO.	SERIAL NO.	DATE OF CALIBRATION	DUE DATE OF CALIBRATION
Test Receiver ROHDE & SCHWARZ	ESCS30	100289	Nov. 16, 2012	Nov. 15, 2013
RF signal cable Woken	5D-FB	Cable-HYC01-01	Dec. 28, 2012	Dec. 27, 2013
V-LISN SCHWARZBECK (Peripheral)	NNBL 8226-2	8226-142	Jun. 27, 2013	Jun. 26, 2014
LISN ROHDE & SCHWARZ (EUT)	ESH3-Z5	835239/001	Feb. 04, 2013	Feb. 03, 2014
Software ADT	BV ADT_Cond_ V7.3.7.3	NA	NA	NA

- NOTE:**
1. The calibration interval of the above test instruments is 12 months and the calibrations are traceable to NML/ROC and NIST/USA.
  2. The test was performed in HwaYa Shielded Room 1.
  3. The VCCI Site Registration No. is C-2040.

### 4.2.3 TEST PROCEDURES

- a. The EUT was placed 0.4 meters from the conducting wall of the shielded room with EUT being connected to the power mains through a line impedance stabilization network (LISN). Other support units were connected to the power mains through another LISN. The two LISNs provide 50 ohm/ 50uH of coupling impedance for the measuring instrument.
- b. Both lines of the power mains connected to the EUT were checked for maximum conducted interference.
- c. The frequency range from 150kHz to 30MHz was searched. Emission levels under (Limit - 20dB) was not recorded.

**NOTE:** All modes of operation were investigated and the worst-case emissions are reported.

### 4.2.4 DEVIATION FROM TEST STANDARD

No deviation.

### 4.2.5 TEST SETUP

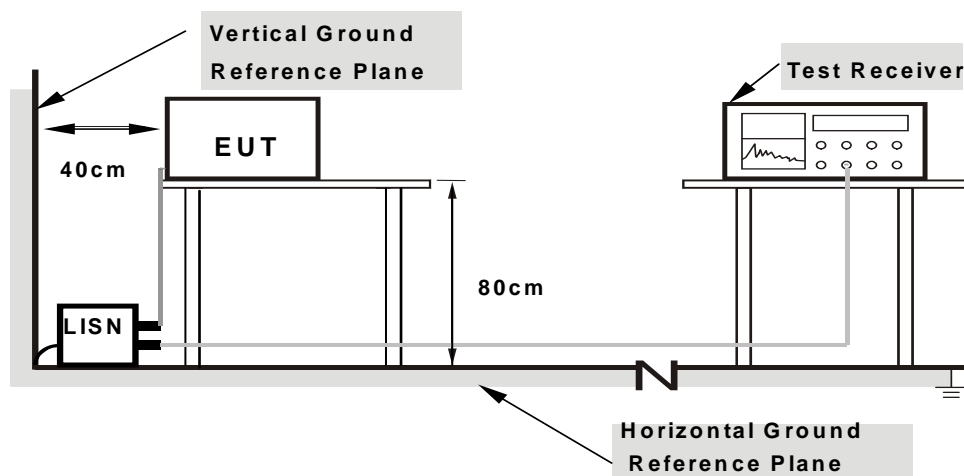

- Note:**
1. Support units were connected to second LISN.
  2. Both of LISNs (AMN) are 80 cm from EUT and at least 80 from other units and other metal planes

For the actual test configuration, please refer to the attached file (Test Setup Photo).

### 4.2.6 EUT OPERATING CONDITIONS

Same as 4.1.6.





## 4.2.7 TEST RESULTS

### CONDUCTED WORST-CASE DATA : 802.11a

<b>PHASE</b>	Line 1	<b>6dB BANDWIDTH</b>	9kHz
<b>CHANNEL</b>	Channel 64		

No	Freq. [MHz]	Corr. Factor (dB)	Reading Value		Emission Level		Limit		Margin	
			[dB (uV)]		[dB (uV)]		[dB (uV)]		(dB)	
			Q.P.	AV.	Q.P.	AV.	Q.P.	AV.	Q.P.	AV.
1	0.18516	0.16	47.99	38.45	48.15	38.61	64.25	54.25	-16.10	-15.64
2	0.24766	0.18	42.86	35.56	43.04	35.74	61.84	51.84	-18.80	-16.10
3	0.61094	0.24	41.29	39.90	41.53	40.14	56.00	46.00	-14.47	-5.86
4	1.95313	0.29	31.14	23.64	31.43	23.93	56.00	46.00	-24.57	-22.07
5	9.53516	0.70	33.80	22.04	34.50	22.74	60.00	50.00	-25.50	-27.26
6	21.00000	1.28	34.51	27.02	35.79	28.30	60.00	50.00	-24.21	-21.70

- REMARKS:**
1. Q.P. and AV. are abbreviations of quasi-peak and average individually.
  2. The emission levels of other frequencies were very low against the limit.
  3. Margin value = Emission level - Limit value
  4. Correction factor = Insertion loss + Cable loss
  5. Emission Level = Correction Factor + Reading Value.

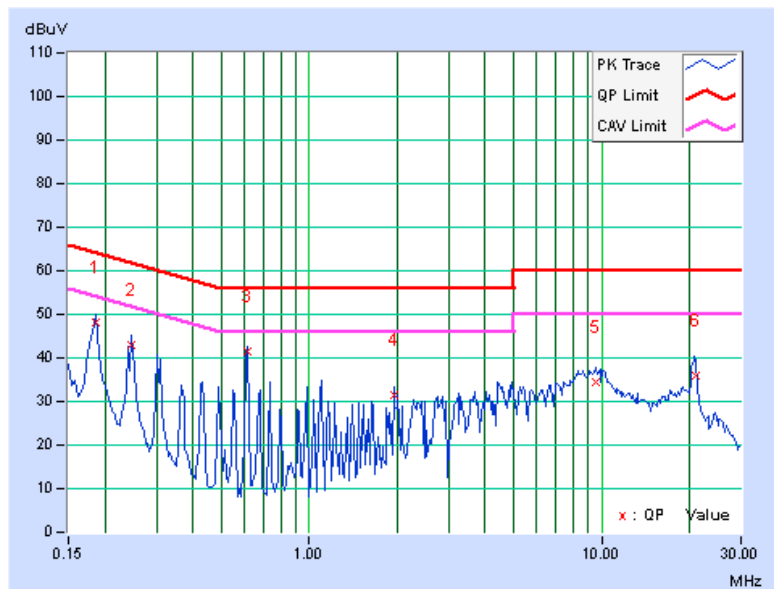

<b>PHASE</b>	Line 2	<b>6dB BANDWIDTH</b>	9kHz
<b>CHANNEL</b>	Channel 64		

No	Freq. [MHz]	Corr. Factor (dB)	Reading Value		Emission Level		Limit		Margin	
			[dB (uV)]		[dB (uV)]		[dB (uV)]		(dB)	
			Q.P.	AV.	Q.P.	AV.	Q.P.	AV.	Q.P.	AV.
1	0.18125	0.17	48.45	38.37	48.62	38.54	64.43	54.43	-15.81	-15.89
2	0.24375	0.19	43.46	35.79	43.65	35.98	61.97	51.97	-18.32	-15.99
3	0.60703	0.24	41.37	39.56	41.61	39.80	56.00	46.00	-14.39	-6.20
4	2.31641	0.30	27.17	20.10	27.47	20.40	56.00	46.00	-28.53	-25.60
5	9.06250	0.57	28.53	16.22	29.10	16.79	60.00	50.00	-30.90	-33.21
6	20.75391	0.96	33.50	25.70	34.46	26.66	60.00	50.00	-25.54	-23.34

- REMARKS:**
1. Q.P. and AV. are abbreviations of quasi-peak and average individually.
  2. The emission levels of other frequencies were very low against the limit.
  3. Margin value = Emission level - Limit value
  4. Correction factor = Insertion loss + Cable loss
  5. Emission Level = Correction Factor + Reading Value.

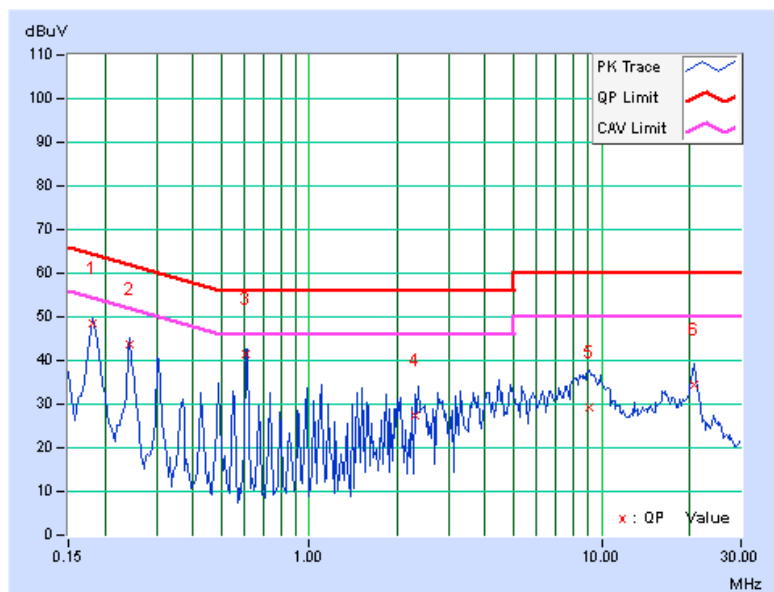



A D T

<b>PHASE</b>	Line 1	<b>6dB BANDWIDTH</b>	9kHz
<b>CHANNEL</b>	Channel 100		

No	Freq. [MHz]	Corr. Factor (dB)	Reading Value		Emission Level		Limit		Margin	
			[dB (uV)]		[dB (uV)]		[dB (uV)]		(dB)	
			Q.P.	AV.	Q.P.	AV.	Q.P.	AV.	Q.P.	AV.
1	0.18125	0.16	48.23	38.13	48.39	38.29	64.43	54.43	-16.04	-16.14
2	0.24766	0.18	42.78	35.40	42.96	35.58	61.84	51.84	-18.88	-16.26
<b>3</b>	<b>0.61094</b>	<b>0.24</b>	<b>41.29</b>	<b>40.06</b>	<b>41.53</b>	<b>40.30</b>	<b>56.00</b>	<b>46.00</b>	<b>-14.47</b>	<b>-5.70</b>
4	4.41797	0.42	32.00	20.69	32.42	21.11	56.00	46.00	-23.58	-24.89
5	9.55469	0.70	33.90	21.10	34.60	21.80	60.00	50.00	-25.40	-28.20
6	20.93359	1.28	34.48	26.67	35.76	27.95	60.00	50.00	-24.24	-22.05

- REMARKS:**
1. Q.P. and AV. are abbreviations of quasi-peak and average individually.
  2. The emission levels of other frequencies were very low against the limit.
  3. Margin value = Emission level - Limit value
  4. Correction factor = Insertion loss + Cable loss
  5. Emission Level = Correction Factor + Reading Value.

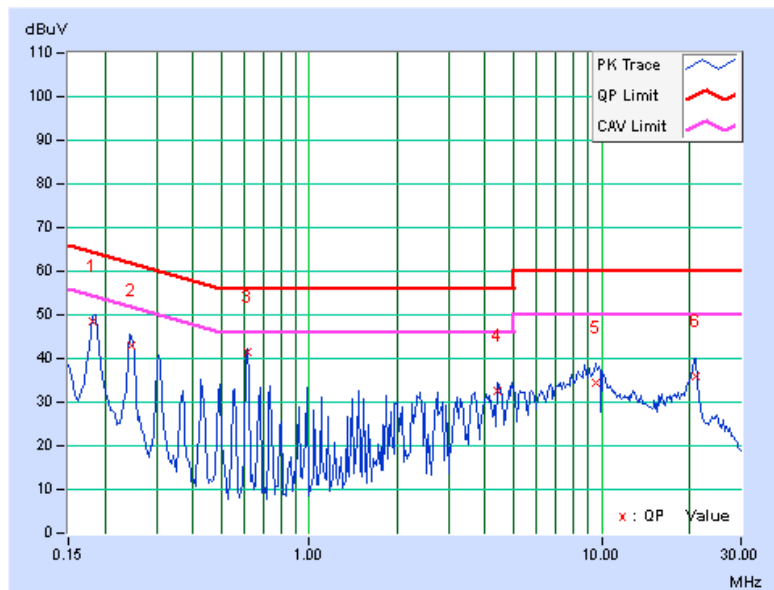



A D T

<b>PHASE</b>	Line 2	<b>6dB BANDWIDTH</b>	9kHz
<b>CHANNEL</b>	Channel 100		

No	Freq. [MHz]	Corr. Factor (dB)	Reading Value		Emission Level		Limit		Margin	
			[dB (uV)]		[dB (uV)]		[dB (uV)]		(dB)	
			Q.P.	AV.	Q.P.	AV.	Q.P.	AV.	Q.P.	AV.
1	0.18125	0.17	48.43	38.35	48.60	38.52	64.43	54.43	-15.83	-15.91
2	0.23984	0.18	42.45	33.09	42.63	33.27	62.10	52.10	-19.47	-18.83
3	0.60703	0.24	41.39	39.44	41.63	39.68	56.00	46.00	-14.37	-6.32
4	2.37891	0.30	28.65	20.83	28.95	21.13	56.00	46.00	-27.05	-24.87
5	8.96094	0.56	32.18	18.99	32.74	19.55	60.00	50.00	-27.26	-30.45
6	20.69531	0.96	33.93	26.05	34.89	27.01	60.00	50.00	-25.11	-22.99

- REMARKS:**
1. Q.P. and AV. are abbreviations of quasi-peak and average individually.
  2. The emission levels of other frequencies were very low against the limit.
  3. Margin value = Emission level - Limit value
  4. Correction factor = Insertion loss + Cable loss
  5. Emission Level = Correction Factor + Reading Value.

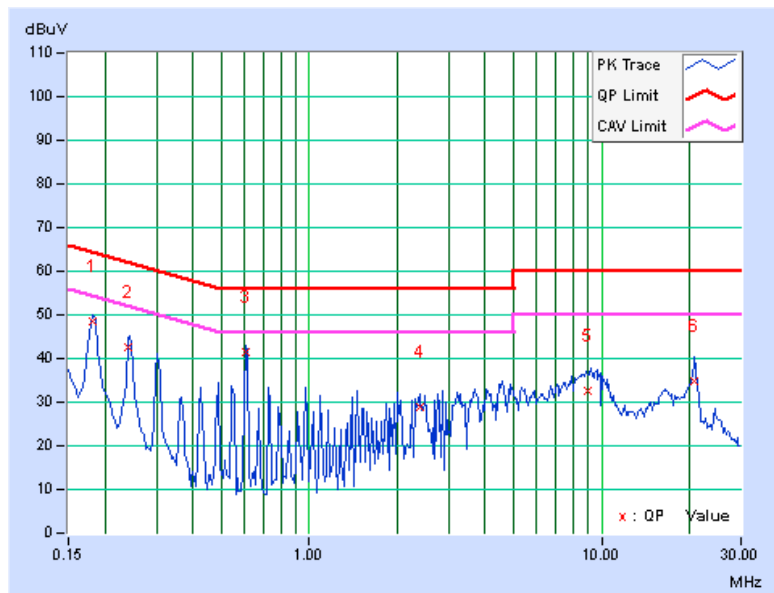

### 4.3 PEAK TRANSMIT POWER MEASUREMENT

#### 4.3.1 LIMITS OF PEAK TRANSMIT POWER MEASUREMENT

FREQUENCY BAND	LIMIT
5.150 ~ 5.250GHz	The lesser of 50mW (17dBm) or 4dBm + 10logB
5.250 ~ 5.350GHz	The lesser of 250mW (24dBm) or 11dBm + 10logB
5.470 ~ 5.725GHz	The lesser of 250mW (24dBm) or 11dBm + 10logB

**NOTE:** Where B is the 26dB emission bandwidth in MHz.

#### 4.3.2 TEST SETUP

##### FOR POWER OUTPUT MEASUREMENT

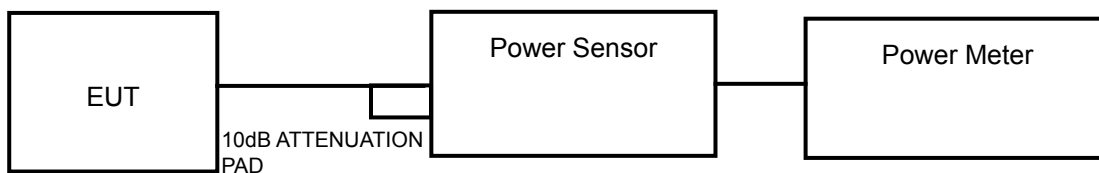

##### FOR 26dB BANDWIDTH

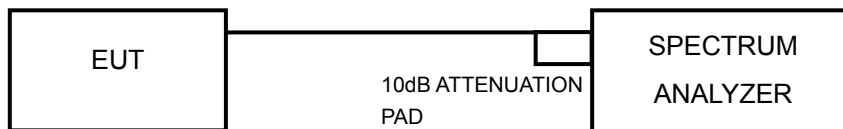

### 4.3.3 TEST INSTRUMENTS

Refer to section 4.1.3 to get information of above instrument.

### 4.3.4 TEST PROCEDURE

#### FOR AVERAGE POWER MEASUREMENT

Method PM is used to perform output power measurement, trigger and gating function of wide band power meter is enabled to measure max output power of TX on burst. Duty factor is not added to measured value.

#### FOR 26dB BANDWIDTH

- 1) Set RBW = approximately 1% of the emission bandwidth.
- 2) Set the VBW > RBW.
- 3) Detector = Peak.
- 4) Trace mode = max hold.
- 5) Measure the maximum width of the emission that is 26 dB down from the peak of the emission. Compare this with the RBW setting of the analyzer. Readjust RBW and repeat measurement as needed until the RBW/EBW ratio is approximately 1%.

### 4.3.5 DEVIATION FROM TEST STANDARD

No deviation.

### 4.3.6 EUT OPERATING CONDITIONS

The software provided by client to enable the EUT under transmission condition continuously at specific channel frequencies individually.

### 4.3.7 TEST RESULTS

#### POWER OUTPUT:

##### 802.11a

CHANNEL	CHANNEL FREQUENCY (MHz)	AVERAGE POWER (mW)	AVERAGE POWER (dBm)	POWER LIMIT (dBm)	PASS/FAIL
36	5180	13.583	11.33	17	PASS
40	5200	14.622	11.65	17	PASS
48	5240	<b>17.298</b>	12.38	17	PASS
52	5260	18.197	12.60	24	PASS
60	5300	22.909	13.60	24	PASS
64	5320	<b>23.988</b>	13.80	24	PASS
100	5500	<b>42.073</b>	16.24	24	PASS
116	5580	20.370	13.09	24	PASS
140	5700	24.717	13.93	24	PASS

##### 802.11n (20MHz)

CHANNEL	CHANNEL FREQUENCY (MHz)	AVERAGE POWER (mW)	AVERAGE POWER (dBm)	POWER LIMIT (dBm)	PASS/FAIL
36	5180	12.794	11.07	17	PASS
40	5200	12.764	11.06	17	PASS
48	5240	15.205	11.82	17	PASS
52	5260	16.144	12.08	24	PASS
60	5300	19.861	12.98	24	PASS
64	5320	20.370	13.09	24	PASS
100	5500	38.371	15.84	24	PASS
116	5580	32.063	15.06	24	PASS
140	5700	20.654	13.15	24	PASS



**26dB BANDWIDTH:**

**802.11a**

CHANNEL	CHANNEL FREQUENCY (MHz)	26dBc BANDWIDTH (MHz)	PASS / FAIL
36	5180	28.64	PASS
40	5200	29.85	PASS
48	5240	28.18	PASS
52	5260	28.92	PASS
60	5300	28.94	PASS
64	5320	30.70	PASS
100	5500	31.08	PASS
116	5580	28.31	PASS
140	5700	24.28	PASS

**802.11n (20MHz)**

CHANNEL	CHANNEL FREQUENCY (MHz)	26dBc BANDWIDTH (MHz)	PASS / FAIL
36	5180	29.08	PASS
40	5200	29.19	PASS
48	5240	29.23	PASS
52	5260	29.06	PASS
60	5300	33.74	PASS
64	5320	31.41	PASS
100	5500	30.79	PASS
116	5580	25.99	PASS
140	5700	26.70	PASS



## 4.4 PEAK POWER SPECTRAL DENSITY MEASUREMENT

### 4.4.1 LIMITS OF PEAK POWER SPECTRAL DENSITY MEASUREMENT

FREQUENCY BAND	LIMIT
5.150 ~ 5.250GHz	4dBm
5.250 ~ 5.350GHz	11dBm
5.470 ~ 5.725GHz	11dBm

### 4.4.2 TEST SETUP

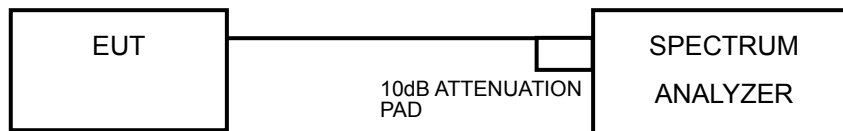

### 4.4.3 TEST INSTRUMENTS

Refer to section 4.1.3 to get information of above instrument.

### 4.4.4 TEST PROCEDURES

- 1) Set span to encompass the entire emission bandwidth (EBW) of the signal.
- 2) Set RBW = 30 KHz, Set VBW  $\geq$  1 MHz, Detector = RMS
- 3) Set Channel power measure = 1MHz
- 4) Sweep time = auto, trigger set to "free run".
- 5) Trace average at least 100 traces in power averaging mode.
- 6) Record the max value and add  $10 \log (1/\text{duty cycle})$

### 4.4.5 DEVIATION FROM TEST STANDARD

No deviation.

### 4.4.6 EUT OPERATING CONDITIONS

Same as 4.3.6.

#### 4.4.7 TEST RESULTS

##### 802.11a

CHANNEL	FREQUENCY (MHz)	PSD W/O DUTY FACTOR (dBm)	DUTY FACTOR	PSD WITH DUTY FACTOR (dBm)	MAXIMUM LIMIT (dBm)	PASS / FAIL
36	5180	-2.20	0.21	-1.99	4	PASS
40	5200	-2.15	0.21	-1.94	4	PASS
48	5240	-0.65	0.21	-0.44	4	PASS
52	5260	0.01	0.21	0.22	11	PASS
60	5300	1.09	0.21	1.30	11	PASS
64	5320	1.91	0.21	2.12	11	PASS
100	5500	4.09	0.21	4.30	11	PASS
116	5580	3.64	0.21	3.85	11	PASS
140	5700	1.98	0.21	2.19	11	PASS

**NOTE:** Refer to section 3.3 for duty cycle spectrum plot.

##### 802.11n (20MHz)

CHANNEL	FREQUENCY (MHz)	PSD W/O DUTY FACTOR (dBm)	DUTY FACTOR	PSD WITH DUTY FACTOR (dBm)	MAXIMUM LIMIT (dBm)	PASS/FAIL
36	5180	-3.04	0.22	-2.82	4	PASS
40	5200	-2.89	0.22	-2.67	4	PASS
48	5240	-1.02	0.22	-0.80	4	PASS
52	5260	-0.68	0.22	-0.46	11	PASS
60	5300	0.54	0.22	0.76	11	PASS
64	5320	0.76	0.22	0.98	11	PASS
100	5500	3.16	0.22	3.38	11	PASS
116	5580	2.57	0.22	2.79	11	PASS
140	5700	1.45	0.22	1.67	11	PASS

**NOTE:** Refer to section 3.3 for duty cycle spectrum plot.

## 4.5 PEAK POWER EXCURSION MEASUREMENT

### 4.5.1 LIMITS OF PEAK POWER EXCURSION MEASUREMENT

Shall not exceed 13 dB.

### 4.5.2 TEST SETUP



### 4.5.3 TEST INSTRUMENTS

Refer to section 4.1.3 to get information of above instrument.

### 4.5.4 TEST PROCEDURE

- 1) Set RBW = 1 MHz, VBW  $\geq$  3 MHz, Detector = peak.
- 2) Trace mode = max-hold. Allow the sweeps to continue until the trace stabilizes.
- 3) Use the peak search function to find the peak of the spectrum.
- 4) Measure the PPSD.
- 5) Compute the ratio of the maximum of the peak-max-hold spectrum to the PPSD.  
Find the worst channel and modulation mode as above test procedure, and follow KDB 789033 D01 General UNII Test Procedures v01r03 and repeat step 1 to 5 for final testing of each modulation mode on a single channel (all modulation types) in a single operating band to compliance with the peak excursion requirement.

### 4.5.5 DEVIATION FROM TEST STANDARD

No deviation.

### 4.5.6 EUT OPERATING CONDITIONS

Same as 4.2.6

### 4.5.7 TEST RESULTS

MODULATION MODE	MODULATION TYPE	CHAN. FREQ. (MHz)	PEAK VALUE (dBm)	PPSD WITHOUT DUTY FACTOR (dBm)	PPSD WITH DUTY FACTOR (dBm)	PEAK EXCURSION (dB)	LIMIT (dB)	PASS /FAIL
802.11a	BPSK	5260	11.60	0.01	0.22	11.38	13	PASS
	QPSK		10.98	-0.29	-0.08	11.06	13	PASS
	16QAM		9.24	-1.84	-1.63	10.87	13	PASS
	64QAM		7.07	-3.57	-3.36	10.43	13	PASS
802.11n (20MHz)	BPSK	5500	14.94	3.16	3.38	11.56	13	PASS
	QPSK		13.89	2.48	2.69	11.20	13	PASS
	16QAM		12.47	1.57	1.78	10.69	13	PASS
	64QAM		10.70	-0.28	-0.07	10.77	13	PASS

**NOTE:** Refer to section 3.3 for duty cycle spectrum plot.

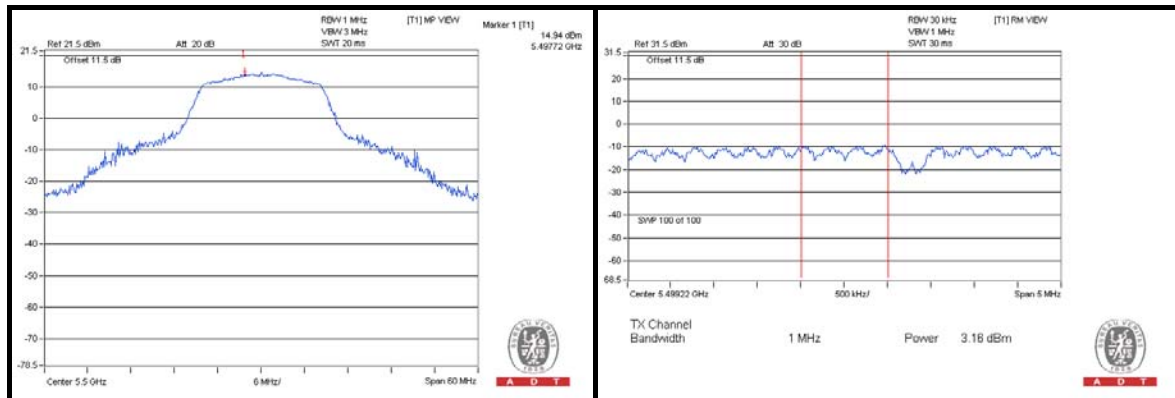

## 4.6 FREQUENCY STABILITY

### 4.6.1 LIMITS OF FREQUENCY STABILITY MEASUREMENT

The frequency of the carrier signal shall be maintained within band of operation

### 4.6.2 TEST SETUP

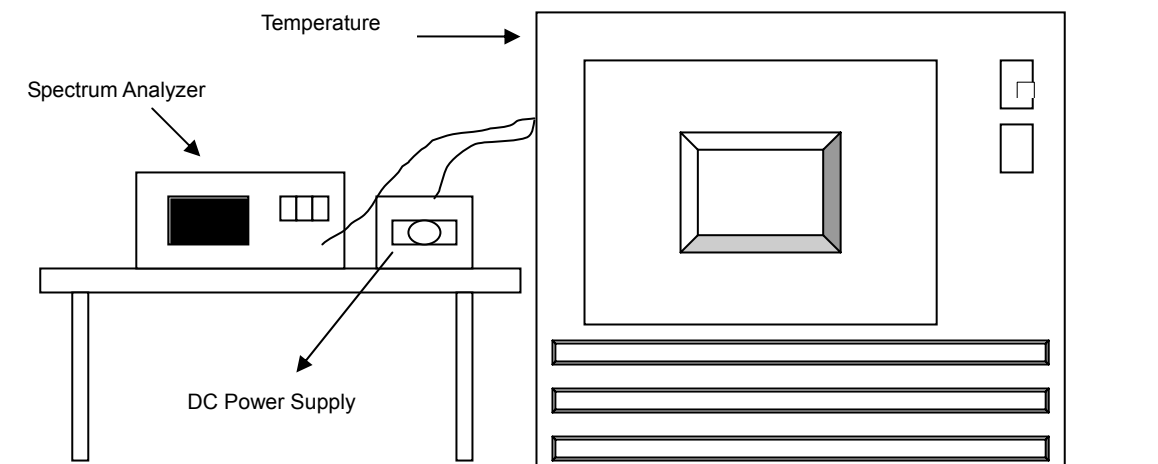

### 4.6.3 TEST INSTRUMENTS

Refer to section 4.1.3 to get information of above instrument.

#### 4.6.4 TEST PROCEDURE

- a. The EUT was placed inside the environmental test chamber and powered by nominal DC voltage.
- b. Turn the EUT on and couple its output to a spectrum analyzer.
- c. Turn the EUT off and set the chamber to the highest temperature specified.
- d. Allow sufficient time (approximately 30 min) for the temperature of the chamber to stabilize, turn the EUT on and measure the operating frequency after 2, 5, and 10 minutes.
- e. Repeat step 2 and 3 with the temperature chamber set to the lowest temperature.
- f. The test chamber was allowed to stabilize at +20 degree C for a minimum of 30 minutes. The supply voltage was then adjusted on the EUT from 85% to 115% and the frequency record.

#### 4.6.5 DEVIATION FROM TEST STANDARD

No deviation.

#### 4.6.6 EUT OPERATING CONDITION

Set the EUT transmit at un-modulation mode to test frequency stability.

#### 4.6.7 TEST RESULTS

FREQUENCY STABILITY VERSUS TEMP.									
OPERATING FREQUENCY: 5320MHz									
TEMP. (°C)	POWER SUPPLY (Vdc)	0 MINUTE		2 MINUTE		5 MINUTE		10 MINUTE	
		Measured Frequency (MHz)	Frequency Drift (%)	Measured Frequency (MHz)	Frequency Drift (%)	Measured Frequency (MHz)	Frequency Drift (%)	Measured Frequency (MHz)	Frequency Drift (%)
50	3.7	5320.0059	0.0001	5320.0117	0.0002	5320.0051	0.0001	5320.0133	0.00025
40	3.7	5319.9927	-0.0001	5320.0021	0.0000	5319.9972	-0.0001	5319.9983	-0.00003
30	3.7	5320.0085	0.0002	5320.0106	0.0002	5320.0084	0.0002	5320.0055	0.00010
20	3.7	5319.9859	-0.0003	5319.9829	-0.0003	5319.9868	-0.0003	5319.9870	-0.00024
10	3.7	5320.0028	0.0001	5319.9973	-0.0001	5319.9993	0.0000	5320.0026	0.00005
0	3.7	5320.0219	0.0004	5320.0305	0.0006	5320.0248	0.0005	5320.0225	0.00042
-10	3.7	5320.0032	0.0001	5320.0008	0.0000	5319.9988	0.0000	5320.0025	0.00005
-20	3.7	5320.0217	0.0004	5320.0212	0.0004	5320.0258	0.0005	5320.0257	0.00048
-30	3.7	5319.9850	-0.0003	5319.9835	-0.0003	5319.9783	-0.0004	5319.9834	-0.00031

FREQUENCY STABILITY VERSUS VOLTAGE									
OPERATING FREQUENCY: 5320MHz									
TEMP. (°C)	POWER SUPPLY (Vdc)	0 MINUTE		2 MINUTE		5 MINUTE		10 MINUTE	
		Measured Frequency (MHz)	Frequency Drift (%)	Measured Frequency (MHz)	Frequency Drift (%)	Measured Frequency (MHz)	Frequency Drift (%)	Measured Frequency (MHz)	Frequency Drift (%)
20	4.2	5319.9856	-0.0003	5319.9825	-0.0003	5319.9858	-0.0003	5319.9869	-0.00025
	3.7	5319.9859	-0.0003	5319.9829	-0.0003	5319.9868	-0.0003	5319.9870	-0.00024
	3.6	5319.9853	-0.0003	5319.9830	-0.0003	5319.9861	-0.0003	5319.9862	-0.00026

## 5. PHOTOGRAPHS OF THE TEST CONFIGURATION

Please refer to the attached file (Test Setup Photo).





## 6. INFORMATION ON THE TESTING LABORATORIES

We, Bureau Veritas Consumer Products Services (H.K.) Ltd., Taoyuan Branch, were founded in 1988 to provide our best service in EMC, Radio, Telecom and Safety consultation. Our laboratories are accredited and approved according to ISO/IEC 17025.

If you have any comments, please feel free to contact us at the following:

**Linko EMC/RF Lab:**

Tel: 886-2-26052180

Fax: 886-2-26051924

**Hsin Chu EMC/RF Lab:**

Tel: 886-3-5935343

Fax: 886-3-5935342

**Hwa Ya EMC/RF/Safety Telecom Lab:**

Tel: 886-3-3183232

Fax: 886-3-3270892

**Email:** [service.adt@tw.bureauveritas.com](mailto:service.adt@tw.bureauveritas.com)

**Web Site:** [www.bureauveritas-adt.com](http://www.bureauveritas-adt.com)

The address and road map of all our labs can be found in our web site also.



A D T

## **7. APPENDIX A – MODIFICATIONS RECORDERS FOR ENGINEERING CHANGES TO THE EUT BY THE LAB**

No modifications were made to the EUT by the lab during the test.

**---END---**