



A D T

# FCC TEST REPORT (PART 27)

**REPORT NO.:** RF120507C13-2

**MODEL NO.:** 8001 3G Cradle

**FCC ID:** Q3N-80013GC

**RECEIVED:** May 07, 2012

**TESTED:** May 16 ~ May 31, 2012

**ISSUED:** Jun. 04, 2012

**APPLICANT:** CIPHERLAB CO., LTD

**ADDRESS:** 12F, 333 Dunhua S. Rd., Sec.2 Taipei, Taiwan 106

**ISSUED BY:** Bureau Veritas Consumer Products Services  
(H.K.) Ltd., Taoyuan Branch

**LAB ADDRESS:** No. 47, 14th Ling, Chia Pau Vil., Lin Kou Dist., New  
Taipei City, Taiwan, R.O.C.

**TEST LOCATION:** No. 19, Hwa Ya 2nd Rd, Wen Hwa Tsuen, Kwei  
Shan Hsiang, Taoyuan Hsien 333, Taiwan, R.O.C.

This report should not be used by the client to claim product certification, approval, or endorsement by TAF or any government agencies.



This report is for your exclusive use. Any copying or replication of this report to or for any other person or entity, or use of our name or trademark, is permitted only with our prior written permission. This report sets forth our findings solely with respect to the test samples identified herein. The results set forth in this report are not indicative or representative of the quality or characteristics of the lot from which a test sample was taken or any similar or identical product unless specifically and expressly noted. Our report includes all of the tests requested by you and the results thereof based upon the information that you provided to us. You have 60 days from date of issuance of this report to notify us of any material error or omission caused by our negligence, provided, however, that such notice shall be in writing and shall specifically address the issue you wish to raise. A failure to raise such issue within the prescribed time shall constitute your unqualified acceptance of the completeness of this report, the tests conducted and the correctness of the report contents. Unless specific mention, the uncertainty of measurement has been explicitly taken into account to declare the compliance or non-compliance to the specification.



## TABLE OF CONTENTS

RELEASE CONTROL RECORD.....	3
1 CERTIFICATION .....	4
2 SUMMARY OF TEST RESULTS.....	5
2.1 MEASUREMENT UNCERTAINTY .....	5
2.2 TEST SITE AND INSTRUMENTS .....	6
3 GENERAL INFORMATION.....	7
3.1 GENERAL DESCRIPTION OF EUT.....	7
3.2 CONFIGURATION OF SYSTEM UNDER TEST.....	8
3.3 DESCRIPTION OF SUPPORT UNITS.....	8
3.4 TEST ITEM AND TEST CONFIGURATION .....	9
3.5 EUT OPERATING CONDITIONS.....	10
3.6 GENERAL DESCRIPTION OF APPLIED STANDARDS.....	10
4 TEST TYPES AND RESULTS .....	11
4.1 OUTPUT POWER MEASUREMENT .....	11
4.1.1 LIMITS OF OUTPUT POWER MEASUREMENT .....	11
4.1.2 TEST PROCEDURES .....	11
4.1.3 TEST SETUP.....	11
4.1.4 TEST RESULTS .....	12
4.2 FREQUENCY STABILITY MEASUREMENT .....	13
4.2.1 LIMITS OF FREQUENCY STABILITY MEASUREMENT .....	13
4.2.2 TEST PROCEDURE .....	13
4.2.3 TEST SETUP.....	13
4.2.4 TEST RESULTS .....	14
4.3 OCCUPIED BANDWIDTH MEASUREMENT.....	15
4.3.1 TEST PROCEDURES .....	15
4.3.2 TEST SETUP.....	15
4.3.3 TEST RESULTS .....	16
4.4 BAND EDGE MEASUREMENT .....	17
4.4.1 LIMITS OF BAND EDGE MEASUREMENT.....	19
4.4.2 TEST SETUP.....	19
4.4.3 TEST PROCEDURES .....	19
4.4.4 TEST RESULTS .....	20
4.5 CONDUCTED SPURIOUS EMISSIONS.....	21
4.5.1 LIMITS OF CONDUCTED SPURIOUS EMISSIONS MEASUREMENT .....	21
4.5.2 TEST PROCEDURE .....	21
4.5.3 TEST SETUP.....	21
4.5.4 TEST RESULTS .....	22
4.6 RADIATED EMISSION MEASUREMENT .....	31
4.6.1 LIMITS OF RADIATED EMISSION MEASUREMENT .....	31
4.6.2 TEST PROCEDURES .....	31
4.6.3 DEVIATION FROM TEST STANDARD .....	31
4.6.4 TEST SETUP.....	32
4.6.5 TEST RESULTS .....	33
5 PHOTOGRAPHS OF THE TEST CONFIGURATION .....	37
6 INFORMATION ON THE TESTING LABORATORIES.....	38
7 APPENDIX A – MODIFICATIONS RECORDERS FOR ENGINEERING CHANGES TO THE EUT BY THE LAB .....	39



A D T

## RELEASE CONTROL RECORD

ISSUE NO.	REASON FOR CHANGE	DATE ISSUED
RF120507C13-2	Original release	Jun. 04, 2012



A D T

## 1 CERTIFICATION

**PRODUCT:** CRADLE

**MODEL:** 8001 3G Cradle

**BRAND:** CIPHERLAB

**APPLICANT:** CIPHERLAB CO., LTD

**TESTED:** May 16 ~ May 31, 2012

**TEST SAMPLE:** ENGINEERING SAMPLE

**STANDARDS:** FCC Part 27

The above equipment (model: 8001 3G Cradle) has been tested by **Bureau Veritas Consumer Products Services (H.K.) Ltd., Taoyuan Branch**, and found compliance with the requirement of the above standards. The test record, data evaluation & Equipment Under Test (EUT) configurations represented herein are true and accurate accounts of the measurements of the sample's EMC characteristics under the conditions specified in this report.

**PREPARED BY** :  , **DATE** : Jun. 04, 2012  
Polly Chien / Specialist

**APPROVED BY** :  , **DATE** : Jun. 04, 2012  
Gary Chang / Technical Manager



A D T

## 2 SUMMARY OF TEST RESULTS

The EUT has been tested according to the following specifications:

APPLIED STANDARD: FCC Part 27 & Part 2			
STANDARD SECTION	TEST TYPE	RESULT	REMARK
2.1046 27.50(d)(4)	Equivalent isotropically radiated power	PASS	Meet the requirement of limit.
2.1055 27.54	Frequency Stability	PASS	Meet the requirement of limit.
2.1049 27.53(h)	Occupied Bandwidth	PASS	Meet the requirement of limit.
27.50(d)(5)	Peak to average ratio	PASS	Meet the requirement of limit.
27.53(h)	Band Edge Measurements	PASS	Meet the requirement of limit.
2.1051 27.53(h)	Conducted Spurious Emissions	PASS	Meet the requirement of limit.
2.1053 27.53(h)	Radiated Spurious Emissions	PASS	Meet the requirement of limit. Minimum passing margin is -22.0dB at 3465.20MHz.& 3505.20MHz.

### 2.1 MEASUREMENT UNCERTAINTY

Where relevant, the following measurement uncertainty levels have been estimated for tests performed on the EUT as specified in CISPR 16-4-2:

MEASUREMENT	FREQUENCY	UNCERTAINTY
Conducted emissions	150kHz~30MHz	2.44 dB
Radiated emissions	30MHz ~ 200MHz	2.93 dB
	200MHz ~1000MHz	2.95 dB
	1GHz ~ 18GHz	2.26 dB
	18GHz ~ 40GHz	1.94 dB

This uncertainty represents an expanded uncertainty expressed at approximately the 95% confidence level using a coverage factor of k=2.



## 2.2 TEST SITE AND INSTRUMENTS

DESCRIPTION & MANUFACTURER	MODEL NO.	SERIAL NO.	DATE OF CALIBRATION	DUE DATE OF CALIBRATION
Test Receiver ROHDE & SCHWARZ	ESCI	100744	Apr. 19, 2012	Apr. 18, 2013
Spectrum Analyzer ROHDE & SCHWARZ	FSP40	100040	Aug. 04, 2011	Aug. 03, 2012
BILOG Antenna SCHWARZBECK	VULB9168	9168-156	Apr. 03, 2012	Apr. 02, 2013
HORN Antenna SCHWARZBECK	BBHA 9120 D	9120D-563	Sep. 06, 2011	Sep. 05, 2012
HORN Antenna SCHWARZBECK	BBHA 9170	148	Jul. 20, 2011	Jul. 19, 2012
Preamplifier Agilent	8449B	3008A01911	Oct. 29, 2011	Oct. 28, 2012
Preamplifier Agilent	8447D	2944A10638	Oct. 29, 2011	Oct. 28, 2012
RF signal cable HUBER+SUHNNER	SUCOFLEX 104	295013/4 283403/4	Aug. 19, 2011	Aug. 18, 2012
RF signal cable Worken	8D-FB	Cable-HYCH9-01	Aug. 13, 2011	Aug. 12, 2012
Software	ADT_Radiated_ V7.6.15.9.2	NA	NA	NA
Antenna Tower EMCO	2070/2080	512.835.4684	NA	NA
Turn Table EMCO	2087-2.03	NA	NA	NA
Antenna Tower & Turn Table Controller EMCO	2090	NA	NA	NA

- NOTE:**
1. The calibration interval of the above test instruments is 12 months and the calibrations are traceable to NML/ROC and NIST/USA.
  2. The test was performed in HwaYa Chamber 9.
  3. The horn antenna and HP preamplifier (model: 8449B) are used only for the measurement of emission frequency above 1GHz if tested.
  4. The FCC Site Registration No. is 460141.
  5. The IC Site Registration No. is IC 7450F-4.



### 3 GENERAL INFORMATION

#### 3.1 GENERAL DESCRIPTION OF EUT

<b>EUT</b>	CRADLE
<b>MODEL NO.</b>	8001 3G Cradle
<b>IMEI Code</b>	35754804*****
<b>HW Version</b>	V1.0
<b>SW Version</b>	V1.0
<b>POWER SUPPLY</b>	5Vdc (Adapter)
<b>MODULATION TYPE</b>	QPSK, BPSK
<b>FREQUENCY RANGE</b>	1712.4MHz ~1752.6MHz
<b>MAX. EIRP POWER</b>	0.5140Watts
<b>WCDMA RELEASE VERSION</b>	6
<b>ANTENNA TYPE</b>	Removable external antenna with 3.33dBi gain
<b>I/O PORTS</b>	Refer to users' manual
<b>DATA CABLE</b>	NA
<b>ACCESSORY DEVICES</b>	Adapter

**NOTE:**

1. The EUT uses following adapters.

<b>Adapter 1</b>	
<b>Brand</b>	I.T.E Power SUPPLY
<b>Model</b>	GPSS-0500200
<b>Input Power</b>	100-240Vac, 50-60Hz, 0.5A
<b>Output Power</b>	5Vdc, 2A
<b>Power Line</b>	1.5m non-shielded cable with 1 core

<b>Adapter 2</b>	
<b>Brand</b>	ADAPTER TECH.
<b>Model</b>	STD-05020U2
<b>Input Power</b>	100-240Vac, 47-63Hz, 0.31A MAX
<b>Output Power</b>	5Vdc, 2A, 10W MAX
<b>Power Line</b>	1.8m non-shielded cable with 1 core

\*\*After pre-tested two of adapters found adapter 2 was the worse one and was chosen for final test.

2. The above EUT information is declared by manufacturer and for more detailed features description, please refer to the manufacturer's specifications or User's Manual.

### 3.2 CONFIGURATION OF SYSTEM UNDER TEST

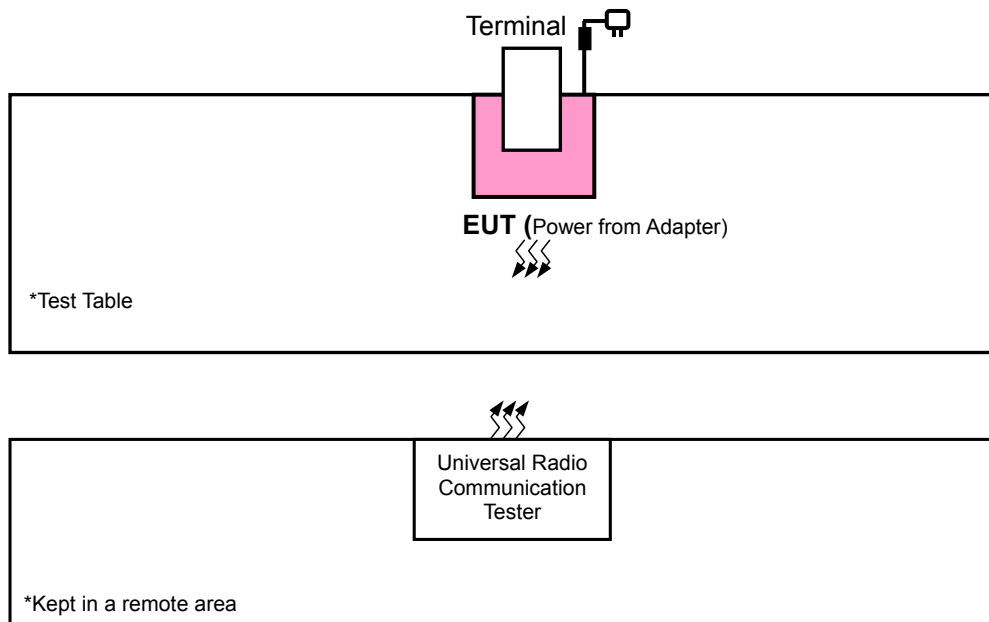

### 3.3 DESCRIPTION OF SUPPORT UNITS

The EUT has been tested as an independent unit together with other necessary accessories or support units. The following support units or accessories were used to form a representative test configuration during the tests.

NO.	PRODUCT	BRAND	MODEL NO.	SERIAL NO.	FCC ID
1	Universal Radio Communication Tester	R&S	CMU200	101372	NA
2	TERMINAL	CIPHERLAB	8001 Terminal	NA	NA

NO.	SIGNAL CABLE DESCRIPTION OF THE ABOVE SUPPORT UNITS
1	NA
2	NA

**NOTE:**

1. All power cords of the above support units are non shielded (1.8m).
2. Item 1 acted as a communication partner to transfer data.
3. Item 2 was provided by the manufacturer.





### 3.4 TEST ITEM AND TEST CONFIGURATION

#### WCDMA MODE

TEST ITEM	AVAILABLE CHANNEL	TESTED CHANNEL	MODE
ERP	1312 to 1513	1312, 1413, 1513	WCDMA
FREQUENCY STABILITY	1312 to 1513	1413	WCDMA
OCCUPIED BANDWIDTH	1312 to 1513	1413	WCDMA, HSDPA, HSUPA
BAND EDGE	1312 to 1513	1312, 1513	WCDMA, HSDPA, HSUPA
CONDCUDED EMISSION	1312 to 1513	1413	WCDMA
RADIATED EMISSION BELOW 1 GHz	1312 to 1513	1413	WCDMA
RADIATED EMISSION ABOCE 1 GHz	1312 to 1513	1312, 1413, 1513	WCDMA

#### TEST CONDITION:

TEST ITEM	ENVIRONMENTAL CONDITIONS	INPUT POWER	TESTED BY
ERP	26deg. C, 65%RH	5.0Vdc	Brad Wu
FREQUENCY STABILITY	26deg. C, 65%RH	5.0Vdc	Brad Wu
OCCUPIED BANDWIDTH	26deg. C, 65%RH	5.0Vdc	Brad Wu
BAND EDGE	26deg. C, 65%RH	5.0Vdc	Brad Wu
CONDCUDED EMISSION	26deg. C, 65%RH	5.0Vdc	Sam Chen
RADIATED EMISSION BELOW 1 GHz	25deg. C, 65%RH	5.0Vdc	Haru Yang
RADIATED EMISSION ABOCE 1 GHz	22deg. C, 71%RH	5.0Vdc	Anderson Hong



A D T

### **3.5 EUT OPERATING CONDITIONS**

The EUT makes a call to the communication simulator. The communication simulator station system controlled a EUT to export maximum output power under transmission mode and specific channel frequency

### **3.6 GENERAL DESCRIPTION OF APPLIED STANDARDS**

The EUT is a RF product. According to the specifications of the manufacturer, it must comply with the requirements of the following standards:

**FCC 47 CFR Part 2**

**FCC 47 CFR Part 27**

**ANSI/TIA/EIA-603-C 2004**

**NOTE:** All test items have been performed and recorded as per the above standards.

## 4 TEST TYPES AND RESULTS

### 4.1 OUTPUT POWER MEASUREMENT

#### 4.1.1 LIMITS OF OUTPUT POWER MEASUREMENT

Fixed, mobile, and portable (hand-held) stations operating in the 1710–1755 MHz band are limited to 1 watt EIRP

#### 4.1.2 TEST PROCEDURES

##### CONDUCTED POWER MEASUREMENT:

The EUT was set up for the maximum power with WCDMA link data modulation and link up with simulator. Set the EUT to transmit under low, middle and high channel and record the power level shown on simulator.

#### 4.1.3 TEST SETUP

##### CONDUCTED POWER MEASUREMENT:

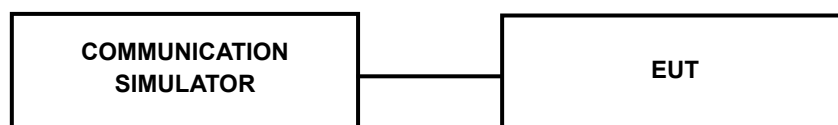

For the actual test configuration, please refer to the attached file (Test Setup Photo).



#### 4.1.4 TEST RESULTS

##### CONDUCTED OUTPUT POWER (dBm)

Band	WCDMA IV		
	1312	1413	1513
Channel	1712.4	1732.6	1752.6
Frequency (MHz)	1712.4	1732.6	1752.6
RMC 12.2K	23.78	23.74	23.71
HSDPA Subtest-1	23.21	23.28	23.24
HSDPA Subtest-2	22.33	23.31	23.26
HSDPA Subtest-3	22.74	22.87	22.78
HSDPA Subtest-4	22.69	22.84	22.75
HSUPA Subtest-1	23.18	22.99	23.19
HSUPA Subtest-2	21.79	21.72	21.63
HSUPA Subtest-3	21.71	22.23	22.09
HSUPA Subtest-4	21.94	21.92	21.87
HSUPA Subtest-5	23.14	23.20	23.14

##### EIRP POWER (dBm)

CHANNEL NO.	FREQUENCY (MHz)	CONDUCTION POWER (dBm)	ANTENNA GAIN (dBi)	OUTPUT POWER	
				dBm	Watt
1312	1712.4	23.78	3.33	27.11	0.5140
1413	1732.6	23.74	3.33	27.07	0.5093
1513	1752.6	23.71	3.33	27.04	0.5058

**NOTE:** EIRP= conducted power(dBm) + Antenna gain(dBi)

## 4.2 FREQUENCY STABILITY MEASUREMENT

### 4.2.1 LIMITS OF FREQUENCY STABILITY MEASUREMENT

The frequency stability shall be sufficient to ensure that the fundamental emissions stay within the authorized bands of operation.

### 4.2.2 TEST PROCEDURE

- a. Device is placed at the oven room. The oven room could control the temperatures and humidity. Power warm up is at least 15 min and power applied should perform before recording frequency error.
- b. EUT is connected the external power supply to control the AC input power. The test voltage range is from minimum to maximum working voltage. Each step shall be record the frequency error rate.
- c. The temperature range step is 10 degrees in this test items. All temperature levels shall be hold the  $\pm 0.5^{\circ}\text{C}$  during the measurement testing. The each temperature step shall be at least 0.5 hours, consider the EUT could be test under the stability condition.

**NOTE:** The frequency error was recorded frequency error from the communication simulator.

### 4.2.3 TEST SETUP

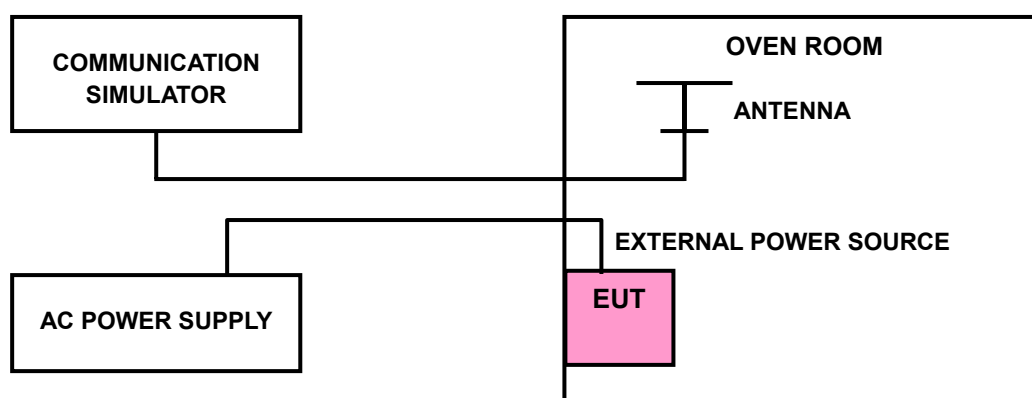



#### 4.2.4 TEST RESULTS

##### FREQUENCY ERROR VS. VOLTAGE

VOLTAGE (Volts)	FREQUENCY ERROR (ppm)	LIMIT (ppm)
126.5	-0.017	2.5
93.5	-0.016	2.5

**NOTE:** The applicant defined the normal working voltage of the adapter is from 93.5Vdc to 126.5Vdc.

##### FREQUENCY ERROR vs. TEMPERATURE.

TEMP. (°C)	FREQUENCY ERROR (ppm)	LIMIT (ppm)
50	-0.016	2.5
40	-0.017	2.5
30	-0.019	2.5
20	-0.020	2.5
10	-0.022	2.5
0	-0.021	2.5
-10	-0.023	2.5
-20	-0.021	2.5
-30	-0.023	2.5

### 4.3 OCCUPIED BANDWIDTH MEASUREMENT

#### 4.3.1 TEST PROCEDURES

The EUT makes a call to the communication simulator. All measurements were done at low, middle and high operational frequency range. The communication simulator station system controlled a EUT to export maximum output power under transmission mode and specific channel frequency. Use OBW measurement function of Spectrum analyzer to measure 99 % occupied bandwidth.

#### 4.3.2 TEST SETUP

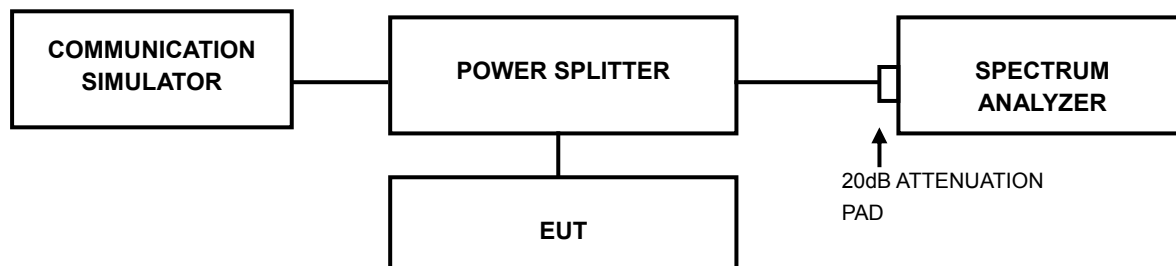

### 4.3.3 TEST RESULTS

CHANNEL	FREQUENCY (MHz)	99% OCCUPIED BANDWIDTH (MHz)		
		WCDMA	HSDPA	HSUPA
1312	1712.4	4.16	4.16	4.14
1413	1732.6	4.16	4.16	4.16
1513	1752.6	4.14	4.14	4.16

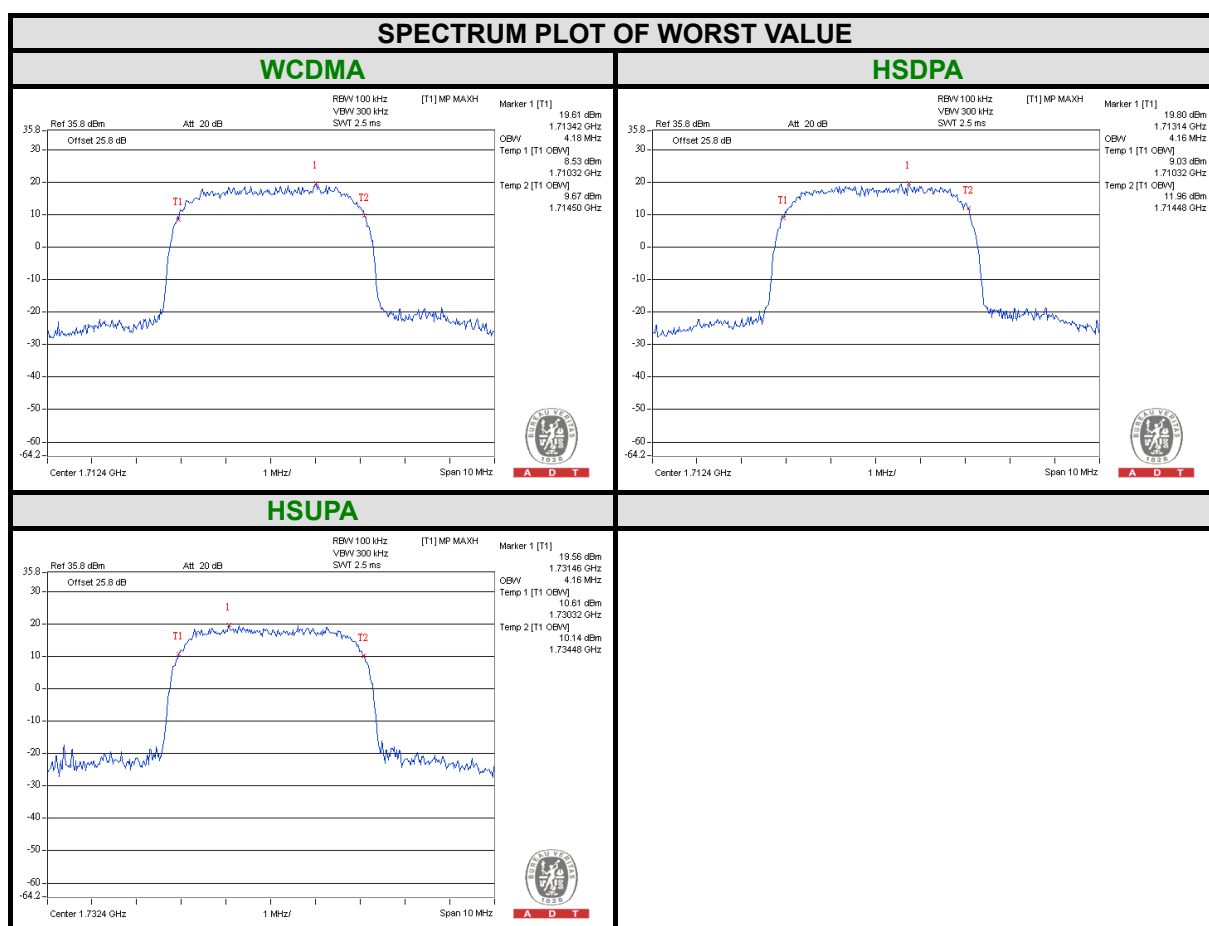



## 4.4 PEAK TO AVERAGE RATIO

### 4.4.1 LIMITS OF PEAK TO AVERAGE RATIO MEASUREMENT

In measuring transmissions in this band using an average power technique, the peak to-average ratio (PAR) of the transmission may not exceed 13 dB

### 4.4.2 TEST SETUP

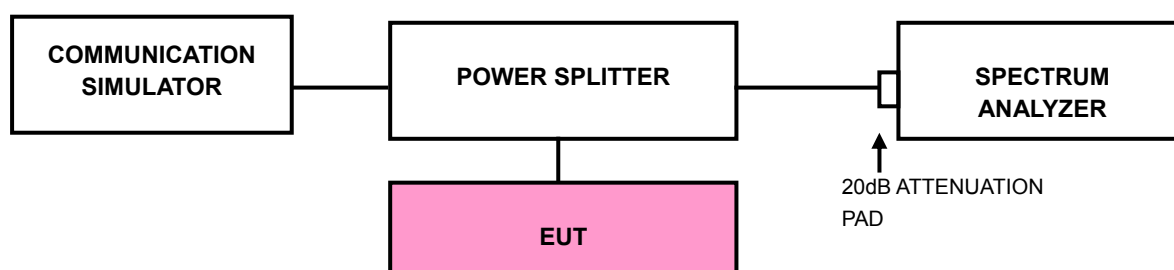

### 4.4.3 TEST PROCEDURES

1. Set resolution/measurement bandwidth  $\geq$  signal's occupied bandwidth;
2. Set the number of counts to a value that stabilizes the measured CCDF curve;
3. Record the maximum PAPR level associated with a probability of 0.1%.

#### 4.4.4 TEST RESULTS

##### WCDMA

CHANNEL	FREQUENCY (MHz)	PEAK TO AVERAGE RATIO (dB)
1312	1712.4	3.23
1413	1732.6	3.10
1513	1752.6	3.18

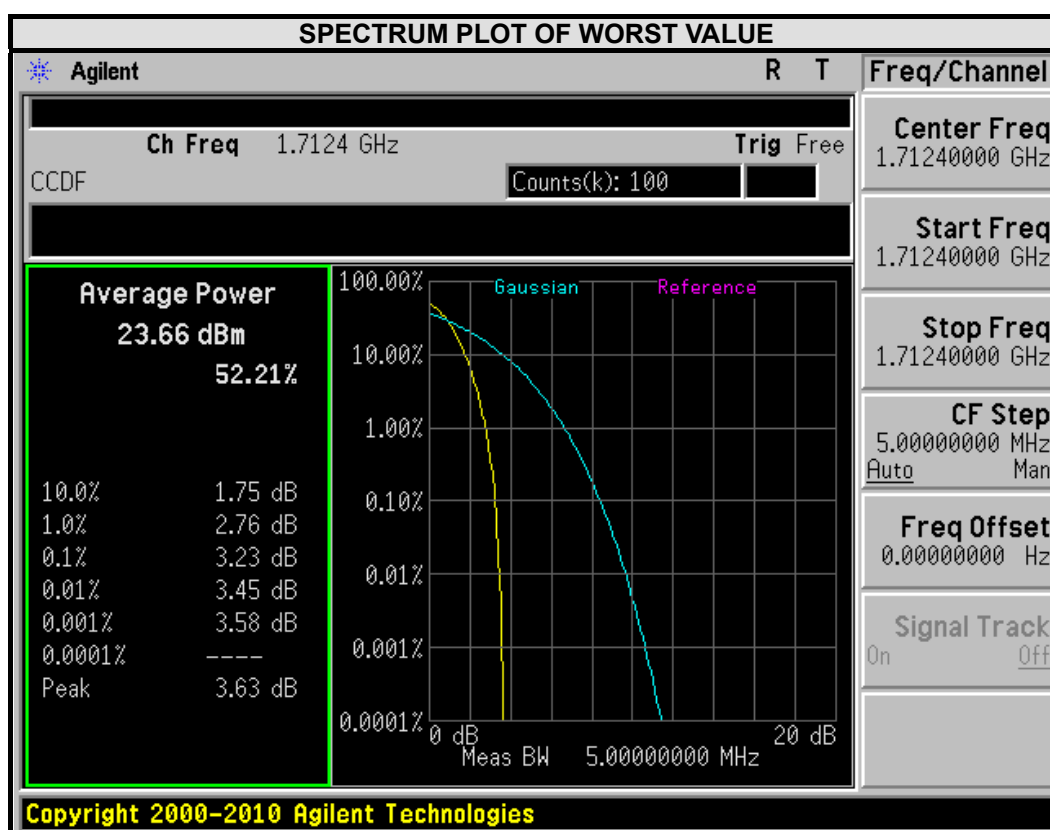

## 4.5 BAND EDGE MEASUREMENT

### 4.5.1 LIMITS OF BAND EDGE MEASUREMENT

Power of any emission outside of the authorized operating frequency ranges must be attenuated below the transmitting power ( $P$ ) by a factor of at least  $43 + 10 \log(P)$  dB. In the 1 MHz bands immediately outside and adjacent to the frequency block a resolution bandwidth of at least one percent of the emission bandwidth of the fundamental emission of the transmitter may be employed.

### 4.5.2 TEST SETUP

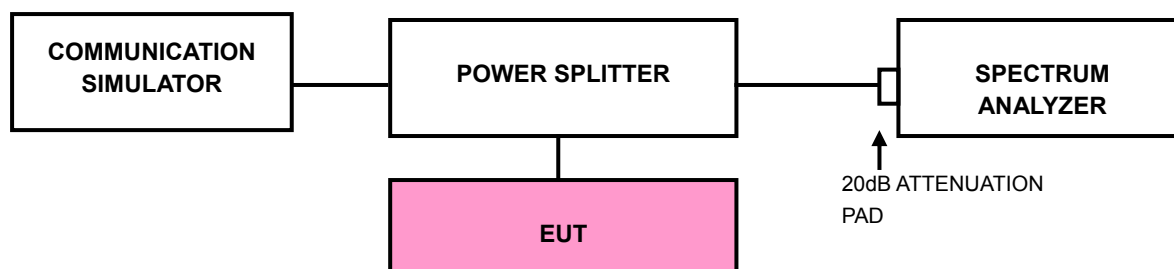

### 4.5.3 TEST PROCEDURES

- All measurements were done at low and high operational frequency range.
- The center frequency of spectrum is the band edge frequency and span is 10MHz. RB of the spectrum is 100kHz and VB of the spectrum is 300kHz (WCDMA).
- Record the max trace plot into the test report.



A D T

### 4.5.4 TEST RESULTS

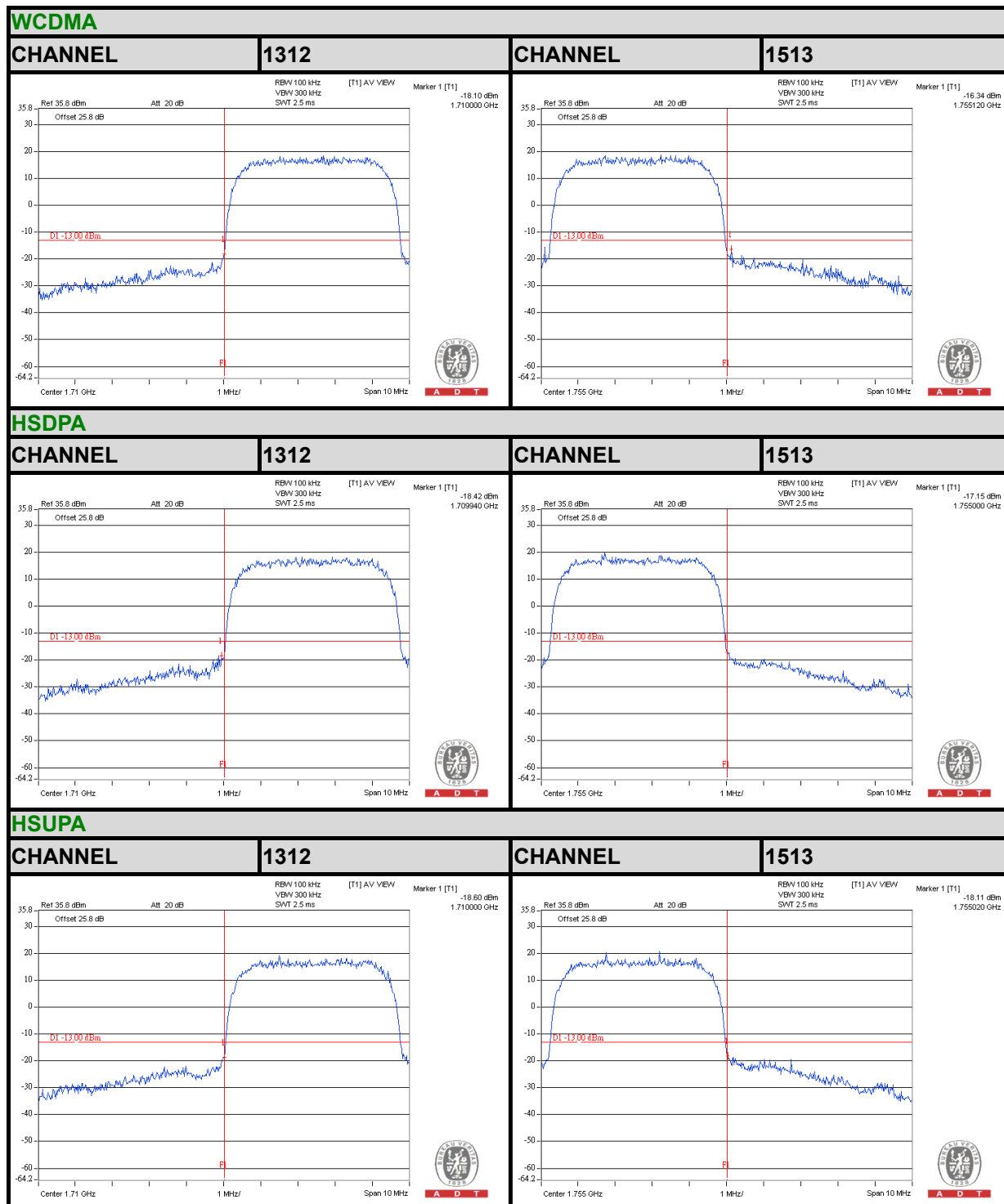

## 4.6 CONDUCTED SPURIOUS EMISSIONS

### 4.6.1 LIMITS OF CONDUCTED SPURIOUS EMISSIONS MEASUREMENT

The power of any emission outside of the authorized operating frequency ranges must be attenuated below the transmitting power (P) by a factor of at least  $43 + 10 \log(P)$  dB. The emission limit equal to  $-13\text{dBm}$ .

### 4.6.2 TEST PROCEDURE

- a. The EUT makes a phone call to the communication simulator. All measurements were done at low, middle and high operational frequency range.
- b. Measuring frequency range is from 9 kHz to 19.1GHz. 20dB attenuation pad is connected with spectrum. RBW=1MHz and VBW=3MHz is used for conducted emission measurement.

### 4.6.3 TEST SETUP

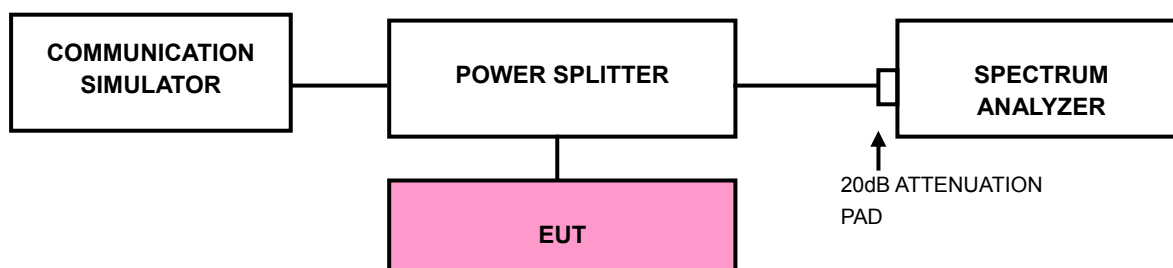



A D T

### 4.6.4 TEST RESULTS





A D T

### CHANNEL 1413

#### FREQUENCY RANGE: 9kHz~3GHz

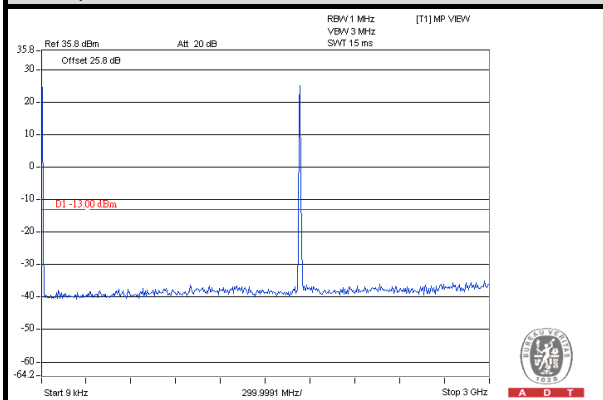

#### FREQUENCY RANGE: 3GHz~10GHz

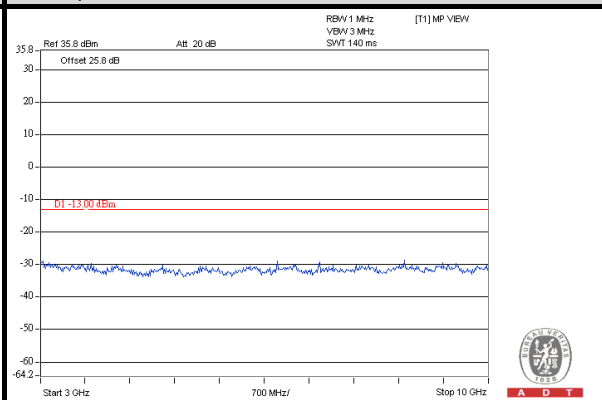

#### FREQUENCY RANGE: 10GHz~20GHz

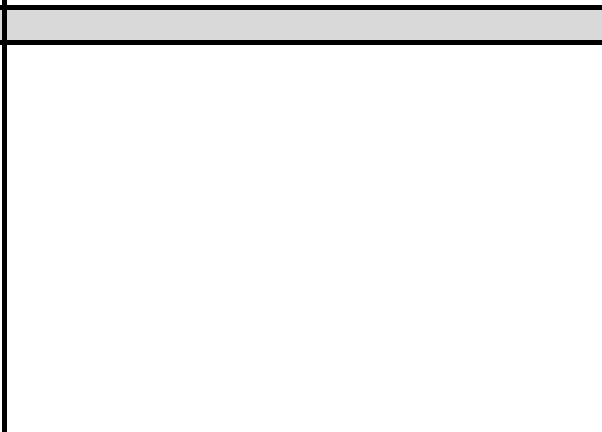
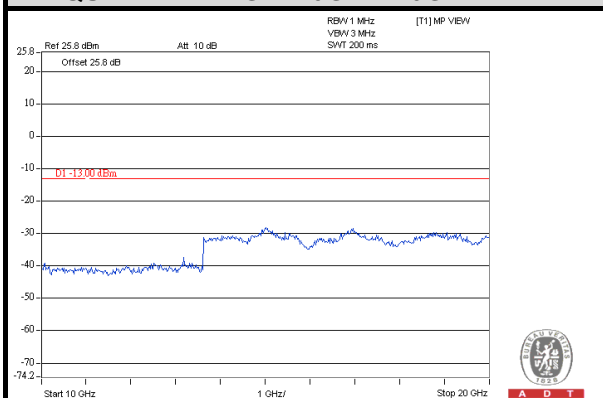



A D T

### CHANNEL 1513

#### FREQUENCY RANGE: 9kHz~3GHz

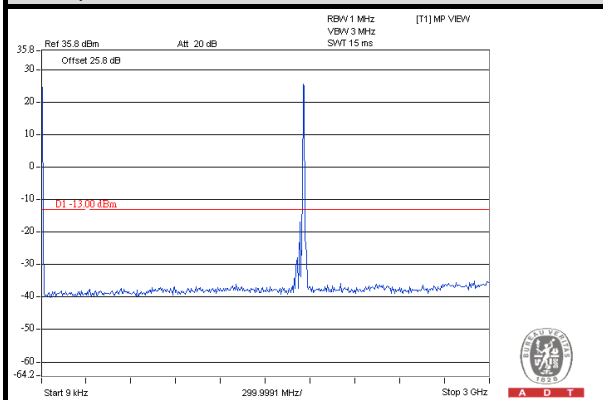

#### FREQUENCY RANGE: 3GHz~10GHz

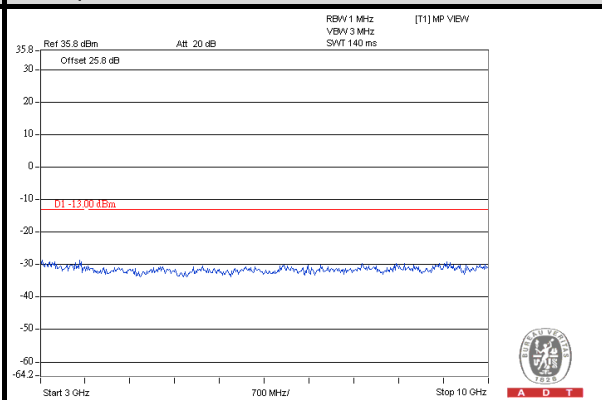

#### FREQUENCY RANGE: 10GHz~20GHz

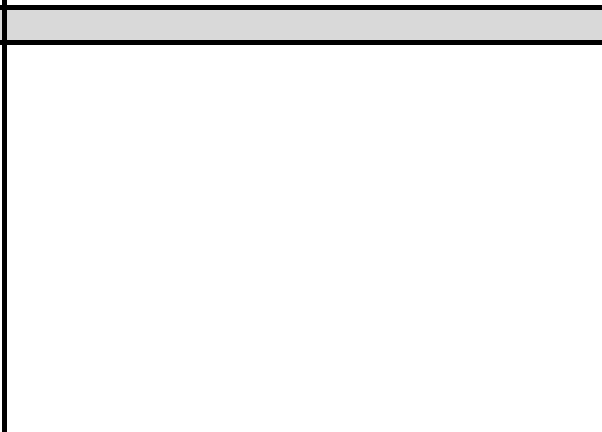
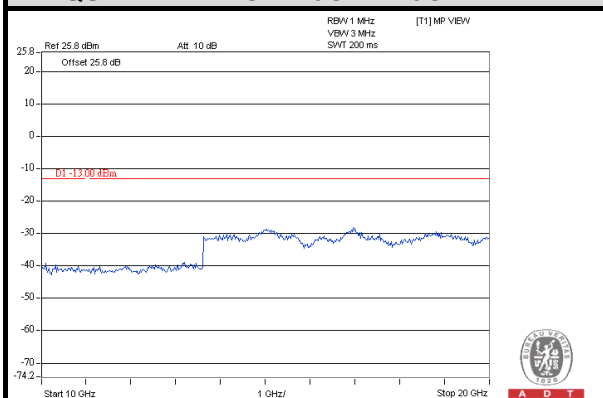





A D T

### HSDPA

### CHANNEL 1312

#### FREQUENCY RANGE: 9kHz~3GHz

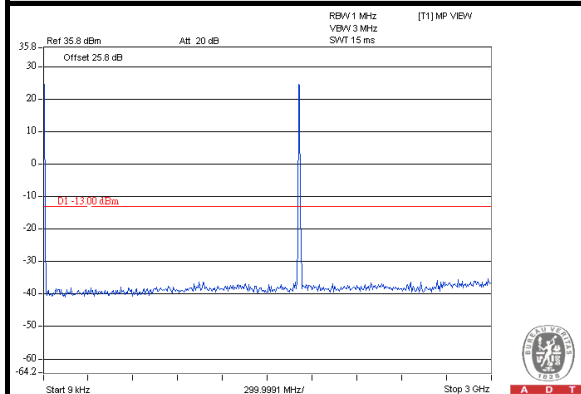

#### FREQUENCY RANGE: 3GHz~10GHz

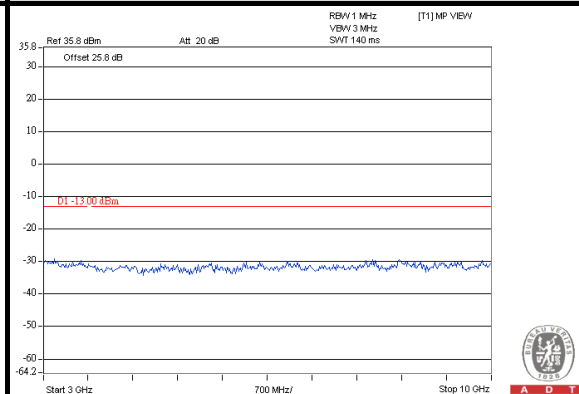

#### FREQUENCY RANGE: 10GHz~20GHz

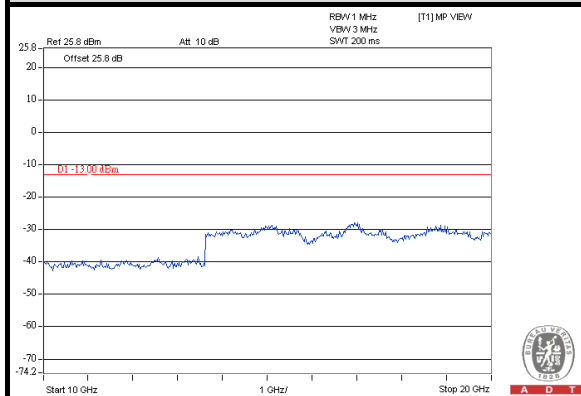



A D T

### CHANNEL 1413

#### FREQUENCY RANGE: 9kHz~3GHz

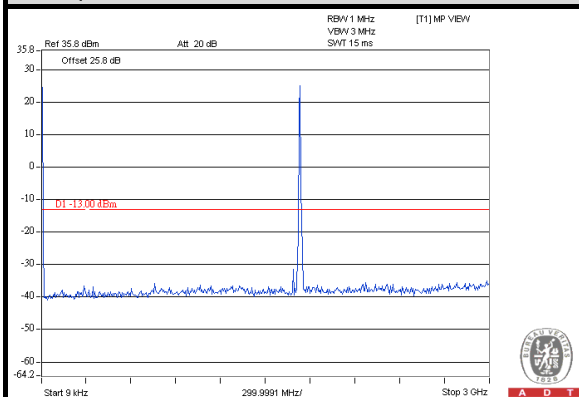

#### FREQUENCY RANGE: 3GHz~10GHz

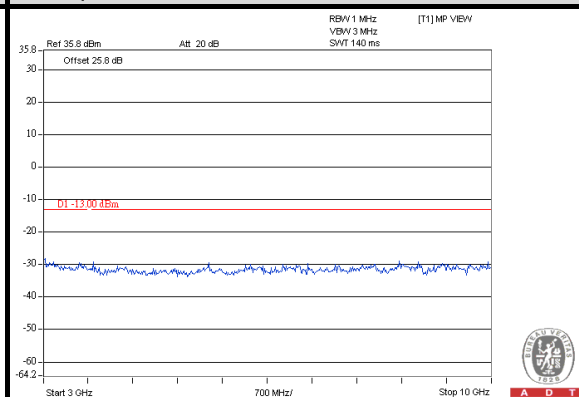

#### FREQUENCY RANGE: 10GHz~20GHz

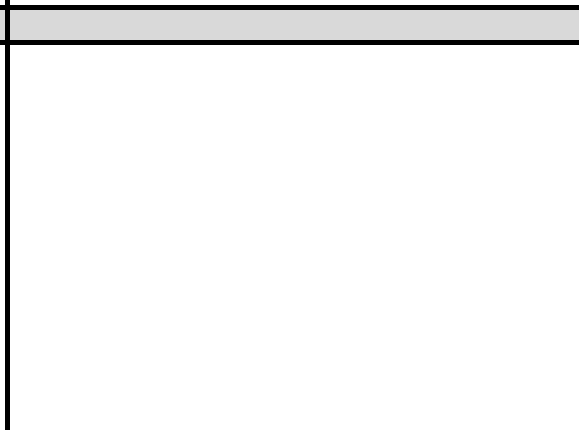
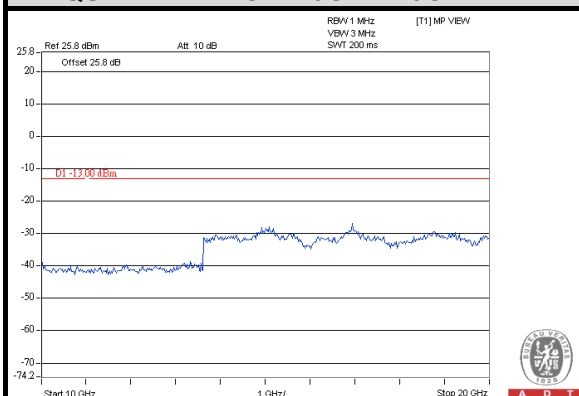



A D T

### CHANNEL 1513

#### FREQUENCY RANGE: 9kHz~3GHz

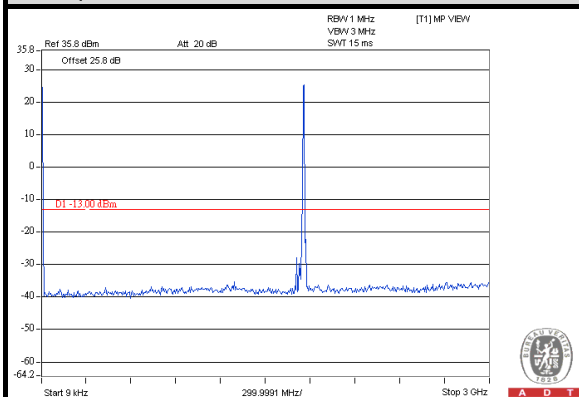

#### FREQUENCY RANGE: 3GHz~10GHz

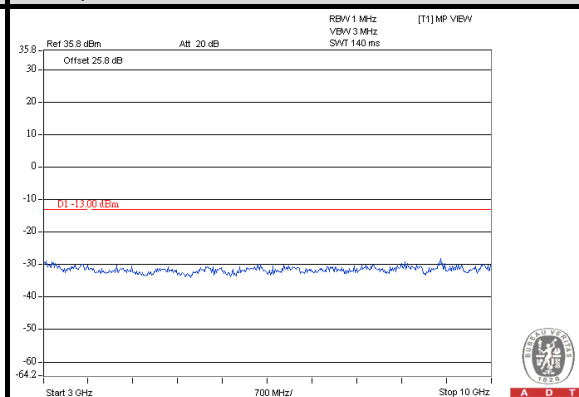

#### FREQUENCY RANGE: 10GHz~20GHz

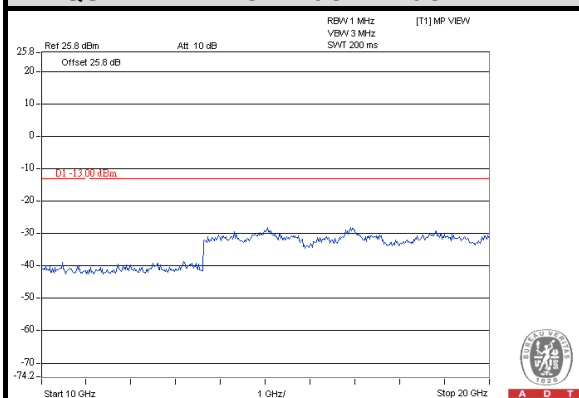



A D T

# HSUPA

## CHANNEL 1312

### FREQUENCY RANGE: 9kHz~3GHz

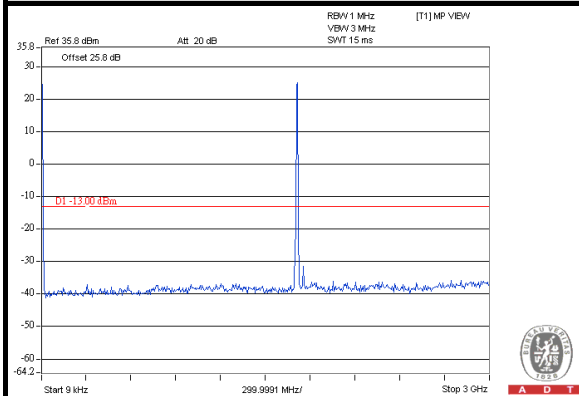

### FREQUENCY RANGE: 3GHz~10GHz

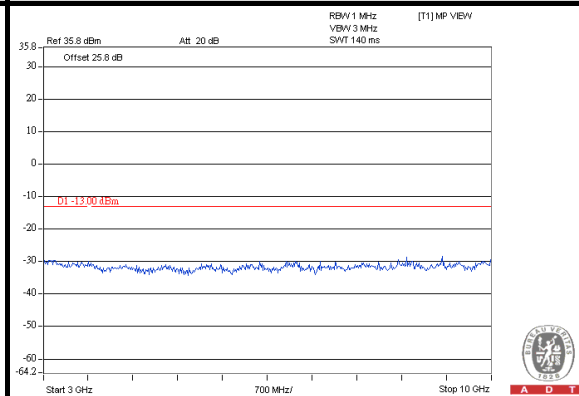

### FREQUENCY RANGE: 10GHz~20GHz

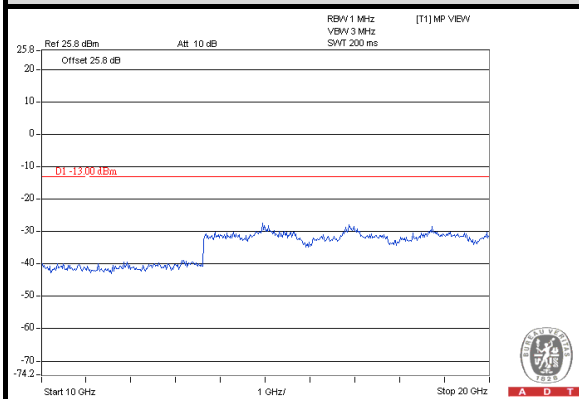



A D T

### CHANNEL 1413

#### FREQUENCY RANGE: 9kHz~3GHz

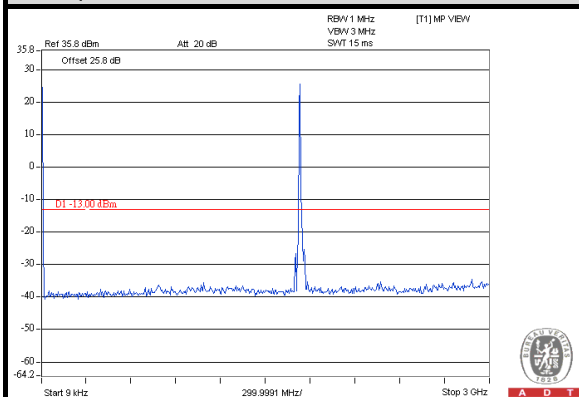

#### FREQUENCY RANGE: 3GHz~10GHz

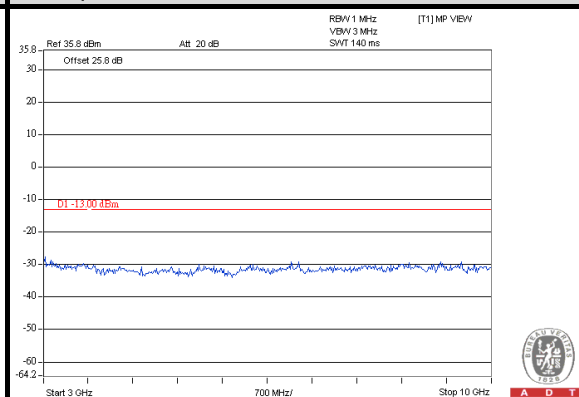

#### FREQUENCY RANGE: 10GHz~20GHz

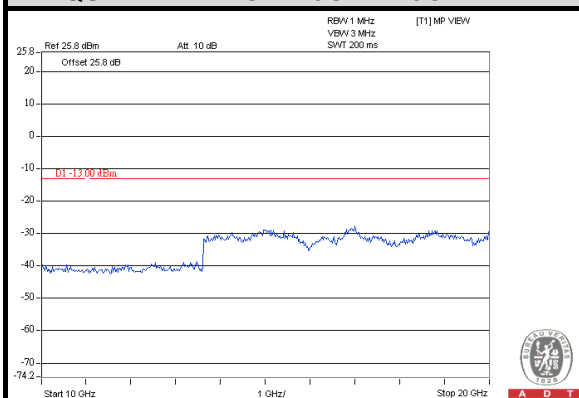



A D T

### CHANNEL 1513

#### FREQUENCY RANGE: 9kHz~3GHz

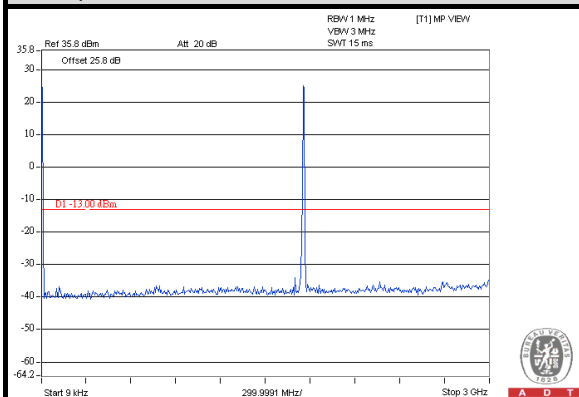

#### FREQUENCY RANGE: 3GHz~10GHz

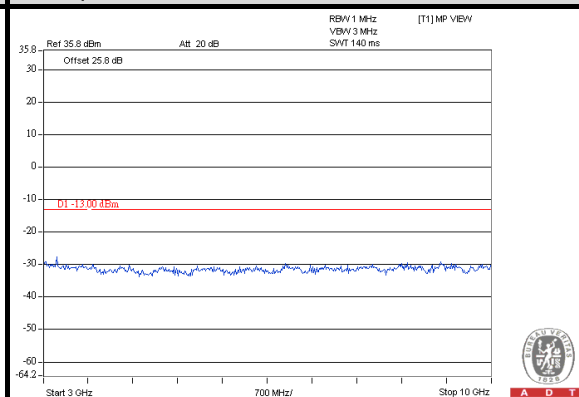

#### FREQUENCY RANGE: 10GHz~20GHz

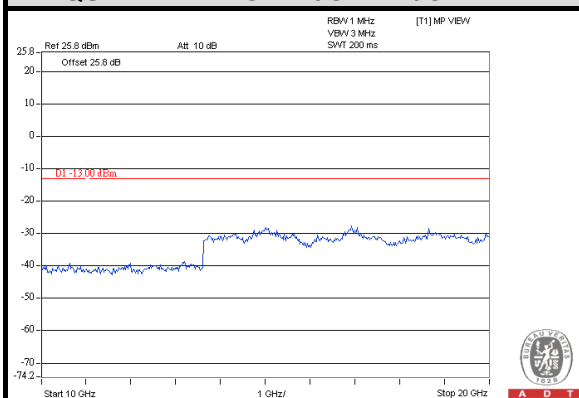

## 4.7 RADIATED EMISSION MEASUREMENT

### 4.7.1 LIMITS OF RADIATED EMISSION MEASUREMENT

The power of any emission outside of the authorized operating frequency ranges must be attenuated below the transmitting power (P) by a factor of at least  $43 + 10 \log(P)$  dB. The emission limit equal to  $-13\text{dBm}$ .

### 4.7.2 TEST PROCEDURES

- a. Substitution method is used for E.I.R.P measurement. In the semi-anechoic chamber, EUT placed on the 0.8m height of Turn Table, rotated the table around 360 degrees to search the maximum radiation power and receiver antenna shall be rotated vertical and horizontal polarization and moved height from 1m to 4m to find the maximum polar radiated power. The “Read Value” is the spectrum reading the maximum power value.
- b. The substitution horn antenna is substituted for EUT at the same position and signals generator export the CW signal to the substitution antenna via a TX cable. Rotated the Turn Table and moved receiving antenna to find the maximum radiation power. Adjust output power level of S.G to get a Value of spectrum reading equal to “Read Value “ of step a. Record the power level of S.G
- c.  $\text{EIRP} = \text{Output power level of S.G} - \text{TX cable loss} + \text{Antenna gain of substitution horn}$ .
- d. E.R.P power can be calculated form E.I.R.P power by subtracting the gain of dipole,  
 $\text{E.R.P power} = \text{E.I.P.R power} - 2.15\text{dBi}$ .

**NOTE:** The resolution bandwidth and video bandwidth of test receiver/spectrum analyzer is 1MHz/3MHz.

### 4.7.3 DEVIATION FROM TEST STANDARD

No deviation

#### 4.7.4 TEST SETUP

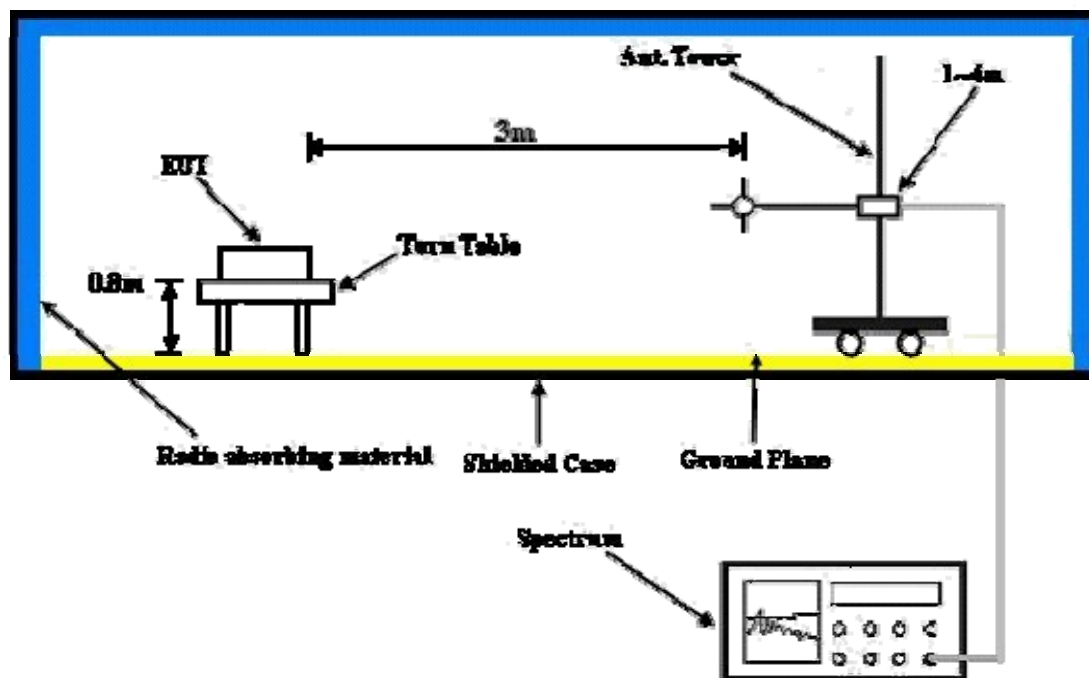

For the actual test configuration, please refer to the attached file (Test Setup Photo).





A D T

#### 4.7.5 TEST RESULTS

Below 1GHz: WCDMA-RMC:

<b>MODE</b>	TX channel 1413	<b>FREQUENCY RANGE</b>	Below 1000MHz
<b>ENVIRONMENTAL CONDITIONS</b>	25deg. C, 65%RH	<b>INPUT POWER</b>	120Vac, 60 Hz
<b>TESTED BY</b>	Haru Yang		

ANTENNA POLARITY & TEST DISTANCE: HORIZONTAL AT 3 M							
No.	Freq. (MHz)	Reading (dBm)	S.G Power Value (dBm)	Correction Factor (dB)	EIRP (dBm)	Limit (dBm)	Margin (dB)
1	31.94	-61.4	-45.0	-12.4	-57.4	-13.0	-44.4
2	70.82	-59.1	-61.3	-4.7	-66.0	-13.0	-53.0
3	156.35	-60.7	-64.6	0.0	-64.6	-13.0	-51.6
4	218.56	-56.5	-68.1	5.5	-62.6	-13.0	-49.6
5	461.54	-67.0	-71.9	5.0	-66.9	-13.0	-53.9
6	727.86	-67.9	-68.2	4.9	-63.3	-13.0	-50.3

ANTENNA POLARITY & TEST DISTANCE: VERTICAL AT 3 M							
No.	Freq. (MHz)	Reading (dBm)	S.G Power Value (dBm)	Correction Factor (dB)	EIRP (dBm)	Limit (dBm)	Margin (dB)
1	35.83	-47.4	-41.9	-11.9	-53.8	-13.0	-40.8
2	70.82	-52.7	-54.5	-4.7	-59.2	-13.0	-46.2
3	92.20	-56.2	-60.3	1.1	-59.2	-13.0	-46.2
4	140.80	-59.0	-60.1	0.0	-60.1	-13.0	-47.1
5	496.53	-64.5	-67.8	4.9	-62.9	-13.0	-49.9

#### REMARKS:

1. Power Value (dBm) = S.G Power Value (dBm) + Correction Factor (dB).
2. Correction Factor (dB) = Substitution Antenna Gain (dB) + Cable Loss (dB).



A D T

**Above 1GHz: WCDMA:**

<b>MODE</b>	Channel 1312	<b>FREQUENCY RANGE</b>	Above 1000MHz
<b>INPUT POWER</b>	120Vac, 60 Hz	<b>ENVIRONMENTAL CONDITIONS</b>	22deg. C, 71%RH
<b>TESTED BY</b>	Anderson Hong		

**ANTENNA POLARITY & TEST DISTANCE: HORIZONTAL AT 3 M**

No.	Freq. (MHz)	Reading (dBm)	S.G Power Value (dBm)	Correction Factor (dB)	EIRP (dBm)	Limit (dBm)	Margin (dB)
1	3424.80	-45.3	-44.4	7.1	-37.3	-13.0	-24.3
2	5137.20	-57.1	-50.2	6.6	-43.6	-13.0	-30.6
3	6849.60	-56.7	-44.2	5.0	-39.2	-13.0	-26.2

**ANTENNA POLARITY & TEST DISTANCE: VERTICAL AT 3 M**

No.	Freq. (MHz)	Reading (dBm)	S.G Power Value (dBm)	Correction Factor (dB)	EIRP (dBm)	Limit (dBm)	Margin (dB)
1	3424.80	-43.5	-42.8	7.1	-35.7	-13.0	-22.7
2	5137.20	-56.4	-51.5	6.6	-44.9	-13.0	-31.9
3	6849.60	-56.6	-45.6	5.0	-40.6	-13.0	-27.6

**REMARKS:**

1. Power Value (dBm) = S.G Power Value (dBm) + Correction Factor (dB).
2. Correction Factor (dB) = Substitution Antenna Gain (dB) + Cable Loss (dB).



A D T

<b>MODE</b>	Channel 1413	<b>FREQUENCY RANGE</b>	Above 1000MHz
<b>INPUT POWER</b>	120Vac, 60 Hz	<b>ENVIRONMENTAL CONDITIONS</b>	22deg. C, 71%RH
<b>TESTED BY</b>	Anderson Hong		

<b>ANTENNA POLARITY &amp; TEST DISTANCE: HORIZONTAL AT 3 M</b>							
No.	Freq. (MHz)	Reading (dBm)	S.G Power Value (dBm)	Correction Factor (dB)	EIRP (dBm)	Limit (dBm)	Margin (dB)
1	3465.20	-45.3	-44.4	7.2	-37.2	-13.0	-24.2
2	5197.80	-58.0	-51.0	6.7	-44.3	-13.0	-31.3
3	6930.40	-57.7	-44.9	4.8	-40.1	-13.0	-27.1
<b>ANTENNA POLARITY &amp; TEST DISTANCE: VERTICAL AT 3 M</b>							
No.	Freq. (MHz)	Reading (dBm)	S.G Power Value (dBm)	Correction Factor (dB)	EIRP (dBm)	Limit (dBm)	Margin (dB)
1	3465.20	-43.1	-42.2	7.2	-35.0	-13.0	-22.0
2	5197.80	-57.4	-52.6	6.7	-45.9	-13.0	-32.9
3	6930.40	-57.5	-46.3	4.8	-41.5	-13.0	-28.5

**REMARKS:**

1. Power Value (dBm) = S.G Power Value (dBm) + Correction Factor (dB).
2. Correction Factor (dB) = Substitution Antenna Gain (dB) + Cable Loss (dB).



A D T

<b>MODE</b>	Channel 1513	<b>FREQUENCY RANGE</b>	Above 1000MHz
<b>INPUT POWER</b>	120Vac, 60 Hz	<b>ENVIRONMENTAL CONDITIONS</b>	22deg. C, 71%RH
<b>TESTED BY</b>	Anderson Hong		

<b>ANTENNA POLARITY &amp; TEST DISTANCE: HORIZONTAL AT 3 M</b>							
No.	Freq. (MHz)	Reading (dBm)	S.G Power Value (dBm)	Correction Factor (dB)	EIRP (dBm)	Limit (dBm)	Margin (dB)
1	3505.20	-44.4	-43.4	7.2	-36.2	-13.0	-23.2
2	5257.80	-57.5	-50.3	6.7	-43.6	-13.0	-30.6
3	7010.40	-57.3	-44.4	4.7	-39.7	-13.0	-26.7
<b>ANTENNA POLARITY &amp; TEST DISTANCE: VERTICAL AT 3 M</b>							
No.	Freq. (MHz)	Reading (dBm)	S.G Power Value (dBm)	Correction Factor (dB)	EIRP (dBm)	Limit (dBm)	Margin (dB)
1	3505.20	-43.3	-42.2	7.2	-35.0	-13.0	-22.0
2	5257.80	-56.8	-52.0	6.7	-45.3	-13.0	-32.3
3	7010.40	-57.1	-45.8	4.7	-41.1	-13.0	-28.1

**REMARKS:**

1. Power Value (dBm) = S.G Power Value (dBm) + Correction Factor (dB).
2. Correction Factor (dB) = Substitution Antenna Gain (dB) + Cable Loss (dB).



A D T

## 5 PHOTOGRAPHS OF THE TEST CONFIGURATION

Please refer to the attached file (Test Setup Photo).



A D T

## 6 INFORMATION ON THE TESTING LABORATORIES

We, Bureau Veritas Consumer Products Services (H.K.) Ltd., Taoyuan Branch, were founded in 1988 to provide our best service in EMC, Radio, Telecom and Safety consultation. Our laboratories are accredited and approved according to ISO/IEC 17025.

If you have any comments, please feel free to contact us at the following:

**Linko EMC/RF Lab:**

Tel: 886-2-26052180

Fax: 886-2-26051924

**Hsin Chu EMC/RF Lab:**

Tel: 886-3-5935343

Fax: 886-3-5935342

**Hwa Ya EMC/RF/Safety/Telecom Lab:**

Tel: 886-3-3183232

Fax: 886-3-3270892

**Email:** [service.adt@tw.bureauveritas.com](mailto:service.adt@tw.bureauveritas.com)

**Web Site:** [www.adt.com.tw](http://www.adt.com.tw)

The address and road map of all our labs can be found in our web site also.



A D T

## **7 APPENDIX A – MODIFICATIONS RECORDERS FOR ENGINEERING CHANGES TO THE EUT BY THE LAB**

No any modifications are made to the EUT by the lab during the test.

**---END---**