



**Test Report No. 9412327172/1**

**For RADWIN Ltd**

**Equipment Under Test:**

**5.8 GHz Smart Antenna Outdoor Radio Device**

**Model: RADWIN 2000 JET/RADWIN 5000 JET**

**From The Standards Institution  
Of Israel  
Industry Division  
Electronics & Telematics Laboratory  
EMC Branch**



**ACLASS Accreditation Services**

**Certificate Number: AT-1359**



**Test report No:** 9412327172/1

Page 2 of 75 Pages

**Title:** 5.8 GHz Smart Antenna Outdoor Radio Device

**Model:** RADWIN 2000 JET/RADWIN 5000 JET

## Table of Contents

1.	Applicant information .....	3
2.	Test performance .....	3
3.	Summary of test:.....	5
4.	Equipment under test description.....	6
4.1	General description .....	6
4.2	Environmental evaluation and exposure limit according to FCC CFR 47 part 1, §1.1307 and IC RSS – 102.....	7
4.3	EUT test configuration.....	8
5.	Test results .....	10
5.1	Transmitter characteristics .....	10
5.1.1	Transmitter 6 dB occupied bandwidth.....	10
5.1.2	Maximum peak conducted output power test.....	11
5.1.3	Power spectral density test.....	13
5.1.4	Radiated emissions according to §§ 15.247(d), 15.205(a).....	14
5.1.5	Receiver spurious emission test according to RSS-Gen section 4.10. ....	20
5.2	Radiated emissions test according to § 15.209 .....	21
5.3	Conducted emissions test according to § 15.207, RSS-Gen § 7.2.4 .....	23
APPENDIX A	Photographs .....	24
APPENDIX B	Test equipment used.....	26
APPENDIX C	Plot test results.....	31

**Test report No:** 9412327172/1

Page 3 of 75 Pages

**Title:** 5.8 GHz Smart Antenna Outdoor Radio Device**Model:** RADWIN 2000 JET/RADWIN 5000 JET

## 1. Applicant information

Applicant:	RADWIN Ltd
Address:	27 Habarzel str, Tel-Aviv, 69710, Israel
Sample for test selected by:	The customer
The date of tests:	20, 22 May 2014, 27 April 2015

### Equipment under test information

<b>Description of Equipment Under Test (EUT):</b>	5.8 GHz Smart Antenna Outdoor Radio Device
<b>Model:</b>	RADWIN 2000 JET/RADWIN 5000 JET
<b>Serial Number:</b>	NA
<b>Hardware version:</b>	Prototype
<b>Software version:</b>	Prototype
<b>Manufactured by:</b>	RADWIN Ltd.

## 2. Test performance

<b>Location:</b>	SII EMC Section
<b>Purpose of test:</b>	Apparatus compliance verification in accordance with emission requirements
<b>Test specifications:</b>	47CFR part 15.247, 15.205 15.207. 15.209 and part 1 §1.1310 IC RSS – 210 issue 8, IC RSS – 102.

**NOTE:** The presented Test Report # 9412327172/1 supersedes the previous Test Report # 9412327172.

This Test Report contains 75 pages and may be used only in full.

This Test Report applies only to the specimen tested and may not be applied to other specimens of the same product.

**Test report No:** 9412327172/1**Page 4 of 75 Pages****Title:** 5.8 GHz Smart Antenna Outdoor Radio Device**Model:** RADWIN 2000 JET/RADWIN 5000 JET**Normative References.**

FCC 47 CFR Part 15, Subpart C, 2014	Radio Frequency Devices Subpart C – Intentional Radiators
IC RSS – 210 Annex 8, 2010	Radio Standard Specification 2010, Issue 8, Low-power Licence-exempt Radiocommunication Devices (All Frequency Bands): Category I Equipment.
RSS – Gen , 2010	Radio Standard Specification, Issue 3, General Requirements and Information for the Certification of Radiocommunication Equipment
ANSI C63.10: 2013	American National Standard for Method of Procedures for Compliance Testing of Unlicensed Wireless Devices
FCC OET KDB 558074, June 2014	Guidance for Performing Compliance Measurements on Digital Transmission Systems (DTS) Operating Under §15.247
FCC OET KDB 662911, October 2011	Emissions testing of Transmitters with Multiple Outputs in the Same Band.

**Test report No:** 9412327172/1

Page 5 of 75 Pages

**Title:** 5.8 GHz Smart Antenna Outdoor Radio Device**Model:** RADWIN 2000 JET/RADWIN 5000 JET**3. Summary of test:**

The EUT was found to comply with requirements of: 47CFR Part 15, §§ 15.247, 15.205, 15.209 and IC RSS-210.

Transmitter characteristics	Subclasses
Minimum 6 dB bandwidth	15.247(a)(2); RSS-210 A8.2(a)
Maximum output power	15.247(b)(3); RSS-210 A8.4(5)
Peak power spectral density	15.247(e); RSS-210 A8.2(b)
Out of band spurious emissions radiated	15.205, 15.247(d); RSS-210 A8.5
Receiver spurious emissions radiated	RSS-Gen section 6
Conducted emissions on AC power line	15.207, RSS-Gen section 7.2.2 N/A. PoE DC power option only.
Unwanted radiated emissions below 1 GHz	15.209, RSS-210 section 2.2

Electronics and  
Telematics Laboratory

5 May 2015

Name: Eng. Yuri Rozenberg  
Position: Head of EMC Branch

Name: Michael Feldman  
Position: Test Technician

Measurement uncertainty.

The test equipment has been calibrated according to its recommended procedures and is within the manufacturer's published limit of error.

The laboratory calibrates its standards by a third party (traceable to NIST, USA) on a regular basis according to equipment manufacturer requirements.

In the following table the uncertainty calculation is given.

Test description	Calculated uncertainty $U_{LAB}$
<b><u>Radiated emissions</u></b> electric field strength in a SAR at 3 m distance 30 MHz – 1.0 GHz	$\pm 4.32$ dB
electric field strength in a FAR at 3 m distance 1.0 GHz – 18 GHz	$\pm 4.47$ dB
<b><u>Substitution measurements</u></b> in a FAR at 3 m distance 1.0 GHz – 18 GHz	$\pm 3.41$ dB

**Test report No:** 9412327172/1

Page 6 of 75 Pages

**Title:** 5.8 GHz Smart Antenna Outdoor Radio Device**Model:** RADWIN 2000 JET/RADWIN 5000 JET

#### 4. Equipment under test description.

\*The customer provided description.

##### 4.1 General description

The RADWIN 2000 JET / RADWIN 5000 JET is a Point to Point / Point to Multipoint 2x2 and 3x3 MIMO, high power transceiver. It operates in 5, 10, 20 and 40 MHz channel bandwidths in the frequency range 5725 - 5850 MHz. It is using OFDM transmission technique in TDD Duplexing method.

The RADWIN 2000 JET / RADWIN 5000 JET incorporates an integrated phase array cross-polarized active antenna that supports 2x2 and 3x3 MIMO configuration modes. The antenna is software configurable to use 2x2 mode with the transmission chain 1 and chain 2 being cross polarized to each other. The 3x3 mode is software enabled by splitting chain 2 and chain 3 outputs in the antenna into two vertical paths.

The RADWIN 2000 JET / RADWIN 5000 JET is powered by a PoE device and has a PoE output port option. The RADWIN 2000 JET is the model name for Point to Point software configuration of the device and the RADWIN 5000 JET is the model name for Point to Multipoint software configuration.

##### EUT technical characteristics.

Transmitter technical characteristics.		Note	
Stand-alone/fixed use			
<b>Assigned frequencies ranges.</b>	5725 – 5850 MHz		
<b>Operating frequencies ranges.</b>	5730 – 5845 MHz	5 MHz OBW	
	5730 – 5845 MHz	10 MHz OBW	
	5735 – 5840 MHz	20 MHz OBW	
	5745 – 5830 MHz	40 MHz OBW	
<b>RF channel spacing:</b>	5/10/20/40 MHz	-	
<b>Antenna connection:</b>	Internal antenna connection.		
<b>Type of modulation:</b>	BPSK, QPSK, 16QAM, 64QAM	-	
<b>Type of multiplexing:</b>	OFDM	-	
<b>Modulating test signal:</b>	PRBS	-	
<b>Duty cycle of transmitter during the tests.</b>	94 %		
Antenna information			
Antenna type	Manufacturer	Model	Gain, dBi
Smart Integrated Multi Pole 5 GHz Single Band.	RADWIN Ltd.	AM0156430	20.5

**Test report No:** 9412327172/1

Page 7 of 75 Pages

**Title:** 5.8 GHz Smart Antenna Outdoor Radio Device**Model:** RADWIN 2000 JET/RADWIN 5000 JET

#### 4.2 Environmental evaluation and exposure limit according to FCC CFR 47 part 1, §1.1307 and IC RSS – 102.

Limit for power density for general population/uncontrolled exposure is 1 mW/cm<sup>2</sup> or 10 W/m<sup>2</sup>.

The power density calculation is  $S = (Pt / 4\pi r^2)$ .

Where:

Pt - The transmitted power (EIRP) (mW)

r - The distance from the unit. (cm)

The limit 1 mW/cm<sup>2</sup> can be calculated from the above based on the following data:

Pt- the transmitted power which is equal to the maximum EIR power.

The maximum MIMO EIR power = 48.6 dBm = 72443 mW

Maximum allowed distance “r”, where RF exposure limits may not be exceeded,

$r = \text{SQRT}(72443/4\pi)$  and is more than 76 cm from the antenna main lobe.

### 4.3 EUT test configuration

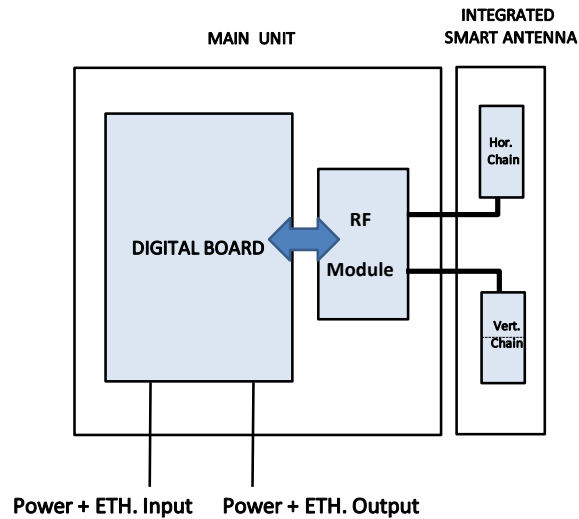

Fig. 1. Transceiver 2x2 mode configuration block diagram.

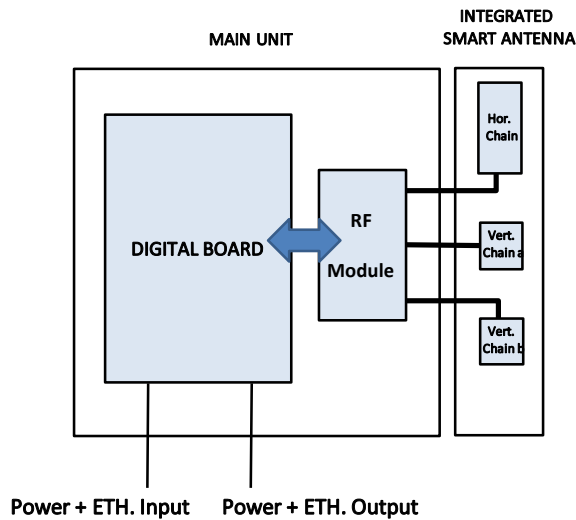

Fig. 2. Transceiver 3x3 mode configuration block diagram.



**Test report No:** 9412327172/1

**Page 9 of 75 Pages**

**Title:** 5.8 GHz Smart Antenna Outdoor Radio Device

**Model:** RADWIN 2000 JET/RADWIN 5000 JET

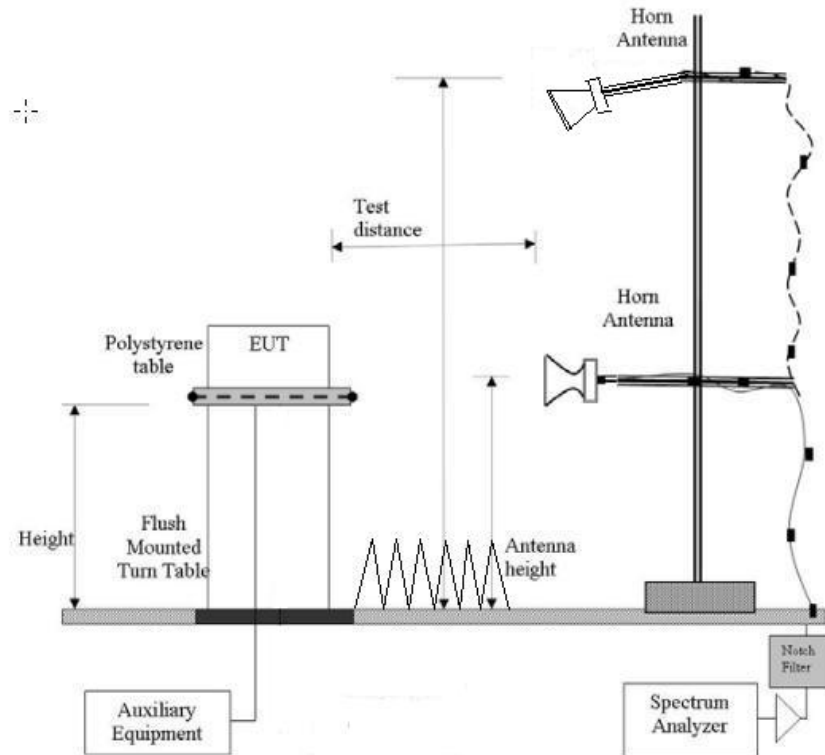

**Fig.3. RE test setup above 1 GHz.**



Test report No: 9412327172/1

Page 10 of 75 Pages

Title: 5.8 GHz Smart Antenna Outdoor Radio Device

Model: RADWIN 2000 JET/RADWIN 5000 JET

### 5. Test results

#### 5.1 Transmitter characteristics

##### 5.1.1 Transmitter 6 dB occupied bandwidth.

Method of measurement            558074 D01 DTS Meas Guidance. Section 8.2  
 Operating Frequency Range        5730– 5845 MHz  
 Detector used                        Peak  
 Resolution bandwidth               >1 % OBW  
 Video bandwidth                    > 3 x RBW.  
 Trace mode                          Max Hold.  
 Sweep time:                         Auto couple.  
 Type of modulation:               64QAM  
 Ambient Temperature    24<sup>0</sup> C    Relative Humidity        51%    Air Pressure        1009 hPa

The minimum -6 dB bandwidth shall be at least 500 kHz.

EBW, MHz	Carrier frequency, MHz	Measured -6 dB bandwidth, MHz	Measured 99 % bandwidth, MHz	Reference to plot#
5.0	5730	4.45	4.58	1
	5780	4.45	4.60	2
	5845	4.47	4.55	3
10	5730	8.82	9.09	4
	5780	8.77	9.09	5
	5845	8.81	9.10	6
20	5735	17.59	18.35	7
	5780	17.59	18.24	8
	5840	17.67	18.40	9
40	5745	36.32	37.10	10
	5780	36.31	37.12	11
	5830	36.37	37.01	12

#### TEST EQUIPMENT USED:

1	5	8				
---	---	---	--	--	--	--



**Test report No:** 9412327172/1

Page 11 of 75 Pages

**Title:** 5.8 GHz Smart Antenna Outdoor Radio Device

**Model:** RADWIN 2000 JET/RADWIN 5000 JET

**5.1.2 Maximum peak conducted output power test.**

<b>Method of measurement</b>	<b>558074 D01 DTS Meas. Guidance. section 9.1</b>					
<b>Operating Frequency Range</b>	<b>5730– 5845 MHz</b>					
<b>Detector used</b>	<b>Peak</b>					
<b>Resolution bandwidth</b>	<b>1 MHz</b>					
<b>Video bandwidth</b>	<b>&gt; RBW.</b>					
<b>Trace mode</b>	<b>Max Hold.</b>					
<b>Type of modulation:</b>	<b>64QAM</b>					
<b>Ambient Temperature</b>	<b>22<sup>0</sup> C</b>	<b>Relative Humidity</b>	<b>53%</b>	<b>Air Pressure</b>	<b>1009 hPa</b>	

For Digital Transmit System the total maximum conducted output power in the 5725 – 5850 MHz band shall not exceed: 1W (30 dBm).

Systems used exclusively for fixed, point-to-point operations may employ transmitting antennas with directional gain greater than 6 dBi without any corresponding reduction in transmitter conducted output power.

For point-to-multipoint use chain output power will be reduced by amount in dB that the directional gains of the antennas exceed 6 dBi. In any 3x3 or 2x2 MIMO modes Chain 1, Chain 2&3 output powers will be reduced by 20.5 – 6 = 14.5 dB.

EBW, MHz	Carrier frequency, MHz	Ch.1 Field strength, dBµV/m	Ch.1 *EIR power, dBm	Ch.2 Field strength, dBµV/m	Ch.2 *EIR power, dBm	Ch.3 Field strength, dBµV/m	Ch.3 *EIR power, dBm	Reference to plot #
5.0	5730	133.51	45.5	130.00	42.0	130.33	42.3	15/27/39
	5780	133.01	45.0	129.76	41.7	130.02	42.0	16/28/40
	5845	133.01	45.0	129.99	42.0	130.31	42.3	17/29/41
10	5730	130.33	45.3	127.23	42.2	127.01	42.0	18/30/42
	5780	130.07	45.1	126.97	42.0	127.31	42.3	19/31/43
	5845	130.29	45.3	127.14	42.1	127.16	42.2	20/32/44
20	5735	127.06	45.1	124.12	42.1	124.05	42.1	21/33/45
	5780	127.43	45.4	124.08	42.1	124.31	42.3	22/34/46
	5840	127.11	45.1	124.14	42.1	124.11	42.1	23/35/47
40	5745	124.54	45.6	121.11	42.1	120.96	42.0	24/36/48
	5780	124.35	45.4	121.12	42.1	120.79	41.8	25/37/49
	5830	124.25	45.3	120.62	41.6	120.97	42.0	26/38/50

\*EIR power = E Field strength (dBµV/m@3m) - 95.2 + (10 Log OBW) + 10 Log (1/x)

x = 0.948 Duty cycle.



Test report No: 9412327172/1

Page 12 of 75 Pages

Title: 5.8 GHz Smart Antenna Outdoor Radio Device

Model: RADWIN 2000 JET/RADWIN 5000 JET

EBW, MHz	Carrier frequency, MHz	*Ch.1 output power, dBm	*Ch.2 output power, dBm	*Ch.3 output power, dBm	**Total output power, dBm	Specified limit, dBm	Margin, dB
5.0	5730	25.0	24.5	24.8	29.5	30.0	-0.5
	5780	24.5	24.2	24.5	29.2	30.0	-0.8
	5845	24.5	24.5	24.8	29.4	30.0	-0.6
10	5730	24.8	24.7	24.5	29.5	30.0	-0.5
	5780	24.6	24.5	24.8	29.4	30.0	-0.6
	5845	24.8	24.6	24.7	29.5	30.0	-0.5
20	5735	24.6	24.6	24.6	29.4	30.0	-0.6
	5780	24.9	24.6	24.8	29.6	30.0	-0.4
	5840	24.6	24.6	24.6	29.4	30.0	-0.6
40	5745	25.1	24.6	24.5	29.5	30.0	-0.5
	5780	24.9	24.6	24.3	29.4	30.0	-0.6
	5830	24.8	24.1	24.5	29.2	30.0	-0.8

\*The chain output power = Chain EIR power – Antenna gain.

Where: Ch.1 antenna gain = 20.5 dBi. Ch.2 = 17.5 dBi. Ch.3 = 17.5 dBi. Ch.2&3 gain = 17.5 + 10 Log (2) = 20.5 dBi.

\*\*Total output power = [10 Log 10 (10<sup>ch1/10</sup> + 10<sup>ch2/10</sup> + 10<sup>ch3/10</sup>)].

TEST EQUIPMENT USED:

1	5	8				
---	---	---	--	--	--	--



**Test report No: 9412327172/1**

**Page 13 of 75 Pages**

**Title: 5.8 GHz Smart Antenna Outdoor Radio Device**

**Model: RADWIN 2000 JET/RADWIN 5000 JET**

### 5.1.3 Power spectral density test

Method of measurement           **558074 D01 DTS Meas Guidance. Section 10.2 (peak PSD)**  
 Operating Frequency Range       **5730– 5845 MHz**  
 Ambient Temperature   22<sup>0</sup> C    Relative Humidity       **53%**    Air Pressure       **1009 hPa**

For digitally modulated systems, the power spectral density conducted from the intentional radiator to the antenna shall not be greater than 8 dBm in any 3 kHz band during any time interval of continuous transmission.

EBW, MHz	Carrier frequency, MHz	Ch.1 Field Strength dBμV/m	Ch.1 EIR PSD, dBm/3 kHz	Ch.2 Field Strength dBμV/m	Ch.2 EIR PSD, dBm/3 kHz	Ch.3 Field Strength dBμV/m	Ch.3 EIR PSD, dBm/3 kHz	Reference to plot #
5.0	5730	108.49	13.5	105.13	10.1	105.17	10.2	51/63/75
	5780	108.50	13.5	106.10	11.1	105.02	10.0	52/64/76
	5845	108.42	13.4	104.62	9.6	105.59	10.6	53/65/77
10	5730	105.77	10.8	102.55	7.5	102.22	7.2	54/66/78
	5780	106.29	11.3	102.96	8.0	103.09	8.1	55/67/79
	5845	105.78	10.8	103.50	8.5	102.77	7.8	56/68/80
20	5735	102.38	7.4	100.01	5.0	100.42	5.4	57/69/81
	5780	103.38	8.4	100.01	5.0	99.76	4.8	58/70/82
	5840	103.54	8.5	100.11	5.1	99.78	4.8	59/71/83
40	5745	99.62	4.6	97.24	2.2	96.38	1.4	60/72/84
	5780	99.91	4.9	97.78	2.8	97.37	2.4	61/73/85
	5830	100.20	5.2	96.54	1.5	97.37	2.4	62/74/86

\*EIR PSD = E Field Strength (dBμV/m@3m) - 95.2 + 10 Log (1/x)  
 x = 0.948 Duty Cycle.

EBW, MHz	Carrier frequency, MHz	*Ch.1 conducted PSD, dBm/3 kHz	*Ch.2 conducted PSD, dBm/3 kHz	*Ch.3 conducted PSD, dBm/3 kHz	**Total conducted PSD, dBm/3 kHz	Specified limit, dBm/3 kHz	Margin, dB
5.0	5730	-7.0	-7.4	-7.3	-2.5	8.0	-10.5
	5780	-7.0	-6.4	-7.5	-2.2	8.0	-10.2
	5845	-7.1	-7.9	-6.9	-2.5	8.0	-10.5
10	5730	-9.7	-10.0	-10.3	-5.2	8.0	-13.2
	5780	-9.2	-9.5	-9.4	-4.6	8.0	-12.6
	5845	-9.7	-9.0	-9.7	-4.7	8.0	-12.7
20	5735	-13.1	-12.5	-12.1	-7.8	8.0	-15.8
	5780	-12.1	-12.5	-12.7	-7.7	8.0	-15.7
	5840	-12.0	-12.4	-12.7	-7.6	8.0	-15.6
40	5745	-15.9	-15.3	-16.1	-11.0	8.0	-19.0
	5780	-15.6	-14.7	-15.1	-10.4	8.0	-18.4
	5830	-15.3	-16.0	-15.1	-10.7	8.0	-18.7

\*The chain PSD = EIR PSD – Antenna gain. Where: Ch.1 antenna gain = 20.5 dBi. Ch.2 = 17.5 dBi. Ch.3 = 17.5 dBi  
 \*\*Total conducted PSD = [10 Log 10 (10<sup>ch1/10</sup> + 10<sup>ch2/10</sup> + 10<sup>ch3/10</sup>)].

**Test report No:** 9412327172/1

Page 14 of 75 Pages

**Title:** 5.8 GHz Smart Antenna Outdoor Radio Device**Model:** RADWIN 2000 JET/RADWIN 5000 JET**5.1.4 Radiated emissions according to §§ 15.247(d), 15.205(a)**

<b>Method of measurement</b>	558074 D01 DTS Meas Guidance. Sec. 12.1.					
<b>Operating Frequency Range</b>	5730– 5845 MHz					
<b>Detector used</b>	Trace 1 – Peak; Trace 2 - Average					
<b>Resolution bandwidth</b>	1 MHz/120 kHz					
<b>Video bandwidth</b>	> RBW.					
<b>Trace mode</b>	Max Hold.					
<b>Ambient Temperature</b>	24 <sup>0</sup> C	<b>Relative Humidity</b>	47%	<b>Air Pressure</b>	1007 hPa	

In any 100 kHz bandwidth outside the frequency band in which the spread spectrum or digitally modulated intentional radiator is operating, the radio frequency power that is produced by the intentional radiator shall be at least 20 dB below that in the 100 kHz bandwidth within the band that contains the highest level of the desired power, based on a radiated measurement, provided the transmitter demonstrates compliance with the peak conducted power limits.

In addition, radiated emissions which fall in the restricted bands, as defined in Section 15.205(a) must also comply with the radiated emission limits specified in Section 15.209(a).

Spurious emission test was performed in two options:

2x2 MIMO - Ch.1 antenna horizontal + Ch.2 antenna vertical

3x3 MIMO - Ch.1 antenna horizontal + (Ch.2 + Ch.3) antenna vertical

**Chain 1. 5 MHz OBW. Carrier frequency = 5730 MHz.**

Frequency, MHz	Antenna polarization V/H	E field, dB $\mu$ V/m	Limit, dB $\mu$ V/m	Margin, dB	Detector type	Note	Reference to plot #
5020.1	H	57.3	74.0	16.7	Peak	*RB	87
5020.1	H	47.1	54.0	6.9	Avg.	RB	87
5450.5	H	58.3	74.0	15.7	Peak	RB	88
5449.1	H	47.5	54.0	6.5	Avg.	RB	88
5725.0	H	88.2	104.8	16.6	Peak	Band edge	90
7420.5	H	59.7	74.0	14.3	Peak	RB	91
7564.0	H	47.3	54.0	6.7	Avg.	RB	91

\*RB – Restricted Band.

**Test report No: 9412327172/1****Page 15 of 75 Pages****Title: 5.8 GHz Smart Antenna Outdoor Radio Device****Model: RADWIN 2000 JET/RADWIN 5000 JET****Carrier frequency = 5780 MHz.**

Frequency, MHz	Antenna polarization V/H	E field, dB $\mu$ V/m	Limit, dB $\mu$ V/m	Margin, dB	Detector type	Note	Reference to plot #
5020.1	H	57.3	74.0	16.7	Peak	RB	94
5020.1	H	47.1	54.0	6.9	Avg.	RB	94
5459.5	H	59.4	74.0	14.6	Peak	RB	95
5459.4	H	48.8	54.0	5.2	Avg.	RB	95
7631.5	H	62.3	74.0	11.7	Peak	RB	97
7450.5	H	49.7	54.0	4.3	Avg.	RB	97

\*RB – Restricted Band.

**Carrier frequency = 5845 MHz.**

Frequency, MHz	Antenna polarization V/H	E field, dB $\mu$ V/m	Limit, dB $\mu$ V/m	Margin, dB	Detector type	Note	Reference to plot #
5020.1	H	57.3	74.0	16.7	Peak	*RB	100
5020.1	H	47.1	54.0	6.9	Avg.	RB	100
5450.5	H	58.4	74.0	15.6	Peak	RB	100
5449.1	H	48.0	54.0	6.0	Avg.	RB	100
5850.0	H	87.0	104.1	17.1	Peak	Band edge.	102
7576.2	H	57.7	74.0	16.3	Peak	RB	103
7595.0	H	46.0	54.0	8.0	Avg.	RB	103

**10 MHz OBW. Carrier frequency = 5730 MHz.**

Frequency, MHz	Antenna polarization V/H	E field, dB $\mu$ V/m	Limit, dB $\mu$ V/m	Margin, dB	Detector type	Note	Reference to plot #
5452.9	H	58.7	74.0	15.3	Peak	RB	105
5452.8	H	48.3	54.0	6.7	Avg.	RB	106
5725.0	H	97.3	102.7	5.4	Peak	Band edge	108

**Carrier frequency = 5845 MHz.**

Frequency, MHz	Antenna polarization V/H	E field, dB $\mu$ V/m	Limit, dB $\mu$ V/m	Margin, dB	Detector type	Note	Reference to plot #
5850.0	H	94.9	101.0	6.1	Peak	Band edge	110
7642.5	H	58.5	74.0	14.3	Peak	RB	111
7564.0	H	46.2	54.0	7.8	Avg.	RB	111

**Test report No:** 9412327172/1

Page 16 of 75 Pages

**Title:** 5.8 GHz Smart Antenna Outdoor Radio Device**Model:** RADWIN 2000 JET/RADWIN 5000 JET**20 MHz OBW. Carrier frequency = 5735 MHz.**

Frequency, MHz	Antenna polarization V/H	E field, dB $\mu$ V/m	Limit, dB $\mu$ V/m	Margin, dB	Detector type	Note	Reference to plot #
5725.0	H	96.3	100.2	3.9	Peak	Band edge	112

**Carrier frequency = 5840 MHz.**

Frequency, MHz	Antenna polarization V/H	E field, dB $\mu$ V/m	Limit, dB $\mu$ V/m	Margin, dB	Detector type	Note	Reference to plot #
5850.0	H	96.4	100.7	4.3	Peak	Band edge	113

**40 MHz OBW. Carrier frequency = 5745 MHz**

Frequency, MHz	Antenna polarization V/H	E field, dB $\mu$ V/m	Limit, dB $\mu$ V/m	Margin, dB	Detector type	Note	Reference to plot #
5725.0	H	96.3	100.2	3.9	Peak	Band edge	112

**Carrier frequency = 5830 MHz**

Frequency, MHz	Antenna polarization V/H	E field, dB $\mu$ V/m	Limit, dB $\mu$ V/m	Margin, dB	Detector type	Note	Reference to plot #
5850.0	H	96.4	100.7	4.3	Peak	Band edge	113

**Chain 2&3.****5 MHz OBW. Carrier frequency = 5730 MHz.**

Frequency, MHz	Antenna polarization V/H	E field, dB $\mu$ V/m	Limit, dB $\mu$ V/m	Margin, dB	Detector type	Note	Reference to plot #
1584	V	40.0	54.0	14.0	Avg.	*RB	116
5456.0	V	59.5	74.0	14.5	Peak	RB	117
5439.8	V	48.2	54.0	5.8	Avg.	RB	117
5725.0	V	88.6	100.2	11.6	Peak	Band edge	119
7582.7	V	57.4	74.0	16.6	Peak	RB	120
7596.5	V	46.0	54.0	8.0	Avg.	RB	120

\*RB – Restricted Band.



**Test report No:** 9412327172/1

Page 17 of 75 Pages

**Title:** 5.8 GHz Smart Antenna Outdoor Radio Device**Model:** RADWIN 2000 JET/RADWIN 5000 JET

Carrier frequency = 5780 MHz.

Frequency, MHz	Antenna polarization V/H	E field, dB $\mu$ V/m	Limit, dB $\mu$ V/m	Margin, dB	Detector type	Note	Reference to plot #
1440.0	V	37.0	54.0	17.0	Avg.	*RB	123
1584.0	V	38.4	54.0	15.6	Avg.	RB	123
5460.0	V	57.8	74.0	14.5	Peak	RB	123
5455.5	V	45.7	54.0	5.8	Avg.	RB	123
7640.0	V	56.5	74.0	17.5	Peak	RB	125
7596.5	V	45.4	54.0	8.6	Avg.	RB	125

Carrier frequency = 5845 MHz.

Frequency, MHz	Antenna polarization V/H	E field, dB $\mu$ V/m	Limit, dB $\mu$ V/m	Margin, dB	Detector type	Note	Reference to plot #
1440.0	V	37.0	54.0	17.0	Avg.	*RB	126
1584.0	V	38.1	54.0	15.9	Avg.	RB	126
5460.0	V	57.0	74.0	17.0	Peak	RB	126
5460.0	V	46.4	54.0	7.6	Avg.	RB	126
5850.0	V	91.8	100.2	8.4	Peak	Band edge	128
7595.0	V	56.6	74.0	17.4	Peak	RB	129
7617.5		45.7	54.0	8.3	Avg.	RB	129

10 MHz OBW. Carrier frequency = 5730 MHz.

Frequency, MHz	Antenna polarization V/H	E field, dB $\mu$ V/m	Limit, dB $\mu$ V/m	Margin, dB	Detector type	Note	Reference to plot #
5447.9	V	55.9	74.0	18.1	Peak	RB	133
5440.0	V	45.6	54.0	8.4	Avg.	RB	133
5725.0	V	87.0	93.3	6.3	Peak	Band edge	135
7589.0	V	57.5	74.0	16.5	Peak	RB	136
7592.0	V	45.4	54.0	8.6	Avg.	RB	136

\*RB – Restricted Band.

**Test report No:** 9412327172/1

Page 18 of 75 Pages

**Title:** 5.8 GHz Smart Antenna Outdoor Radio Device**Model:** RADWIN 2000 JET/RADWIN 5000 JET

Carrier frequency = 5845 MHz.

Frequency, MHz	Antenna polarization V/H	E field, dB $\mu$ V/m	Limit, dB $\mu$ V/m	Margin, dB	Detector type	Note	Reference to plot #
5419.8	V	57.8	74.0	16.2	Peak	RB	137
5455.5	V	47.6	54.0	6.4	Avg.	RB	137
5850.0	V	86.9	94.2	7.2	Peak	Band edge	139
7336.5	V	56.7	74.0	17.3	Peak	RB	140
7459.5	V	45.5	54.0	8.5	Avg.	RB	140

20 MHz OBW. Carrier frequency = 5735 MHz.

Frequency, MHz	Antenna polarization V/H	E field, dB $\mu$ V/m	Limit, dB $\mu$ V/m	Margin, dB	Detector type	Note	Reference to plot #
5725.0	V	86.6	91.2	4.6	Peak	Band edge	141

Carrier frequency = 5840 MHz.

Frequency, MHz	Antenna polarization V/H	E field, dB $\mu$ V/m	Limit, dB $\mu$ V/m	Margin, dB	Detector type	Note	Reference to plot #
5850.0	V	86.1	92.6	6.5	Peak	Band edge	142

**Test report No:** 9412327172/1

Page 19 of 75 Pages

**Title:** 5.8 GHz Smart Antenna Outdoor Radio Device**Model:** RADWIN 2000 JET/RADWIN 5000 JET**40 MHz OBW. Carrier frequency = 5745 MHz**

Frequency, MHz	Antenna polarization V/H	E field, dB $\mu$ V/m	Limit, dB $\mu$ V/m	Margin, dB	Detector type	Note	Reference to plot #
5719.9	V	85.1	88.9	3.8	Peak	Band edge	143
5725.0	V	82.0	88.9	6.9	Peak	Band edge	143

**Carrier frequency = 5830 MHz**

Frequency, MHz	Antenna polarization V/H	E field, dB $\mu$ V/m	Limit, dB $\mu$ V/m	Margin, dB	Detector type	Note	Reference to plot #
5850.0	V	84.0	89.7	5.7	Peak	Band edge	144

**TEST EQUIPMENT USED:**

1	5	8	9	11	16	
---	---	---	---	----	----	--



**Test report No:** 9412327172/1

Page 20 of 75 Pages

**Title:** 5.8 GHz Smart Antenna Outdoor Radio Device

**Model:** RADWIN 2000 JET/RADWIN 5000 JET

**5.1.5 Receiver spurious emission test according to RSS-Gen section 4.10.**

The frequency spectrum was investigated from the lowest radio frequency signal generated in the equipment to at least 3 times of the highest fundamental frequency. Investigation in 1 GHz – 18 GHz frequency band was performed at 1 m test distance with average detector according to limit RSS-Gen section 6.1 table 2.

Test results in 30 – 1000 MHz frequency range are recorded in section 5.2.

Frequency, MHz	Field strength limit $\mu\text{V/m}(\text{dB}\mu\text{V/m})@3\text{m distance}$
30 - 88	100(40)
88 - 216	150(43.5)
216 - 960	200(46)
Above 960	500(54)

**TEST RESULT:**

Test result is presented in plot # 145.

**TEST EQUIPMENT USED:**

1	5	8				
---	---	---	--	--	--	--



**Test report No:** 9412327172/1

Page 21 of 75 Pages

**Title:** 5.8 GHz Smart Antenna Outdoor Radio Device

**Model:** RADWIN 2000 JET/RADWIN 5000 JET

### 5.2 Radiated emissions test according to § 15.209

<b>Method of measurement</b>	558074 D01 DTS Meas Guidance. Sec. 12.1.				
<b>Detector used</b>	CISPR Quasi-Peak				
<b>Resolution bandwidth</b>	9 kHz/120 kHz				
<b>Video bandwidth</b>	>3 x RBW.				
<b>Trace mode</b>	Free run				
<b>Ambient Temperature</b>	24 <sup>0</sup> C	<b>Relative Humidity</b>	55%	<b>Air Pressure</b>	1012 hPa

#### TEST DESCRIPTION:

The measurements were performed at 3m test distance in Anechoic chamber. The EUT was arranged on a polystyrene table 0.8 m height placed on the turn - table. The Active Loop antenna in 0.15 MHz to 30 MHz frequency band and Biconilog antenna in 30 MHz – 1.0 GHz frequency band were used. The emission level was maximized by initially rotating turntable through 360°, varying the antenna height between 1 m and 4 m, rerouting EUT cables and changing antenna polarization from vertical to horizontal.

#### REQUIREMENTS:

EUT radiated emission shall not exceed value required in section 15.209

#### TEST RESULT:

Test results are presented in table 1 and in plot # 146.

#### TEST EQUIPMENT USED:

1	10	15	17			
---	----	----	----	--	--	--

**Test report No:** 9412327172/1

Page 22 of 75 Pages

**Title:** 5.8 GHz Smart Antenna Outdoor Radio Device**Model:** RADWIN 2000 JET/RADWIN 5000 JET**Table #1. Radiated emission test result.**

Frequency (MHz)	Antenna Polariz. V/H	Antenna Height (m)	Turn- table Angle (°)	Emission Level Note 1 dB $\mu$ V/m	Limit @ 3 m dB $\mu$ V/m	Margin Note 2 (dB)	Result.
3.93	V	1.0	194	56.3	69.5	13.2	Pass
4.24	V	1.0	128	54.8	69.5	14.7	Pass
6.37	V	1.0	261	61.8	69.5	7.7	Pass
32.3	V	1.0	180	34.0	40.0	6.0	Pass
45.5	V	1.0	140	31.4	40.0	8.6	Pass
125.0	V	1.0	161	35.2	43.5	8.3	Pass
150.0	V	1.1	65	33.5	43.5	10.0	Pass
250.0	V	1.0	190	32.3	46.0	13.7	Pass
333.3	V	1.1	180	43.6	46.0	2.4	Pass
870.0	H	1.0	130	41.5	46.0	4.5	Pass

Note 1: Emission level = E Reading (dB $\mu$ V) + Cable loss (dB) + Antenna Factor (dB/m)  
For Cable Loss and Antenna Factor refer to Appendix 2.

Note 2: Margin (dB) = Limit (dB $\mu$ V/m) – Emission level (dB $\mu$ V/m)



**Test report No:** 9412327172/1

Page 23 of 75 Pages

**Title:** 5.8 GHz Smart Antenna Outdoor Radio Device

**Model:** RADWIN 2000 JET/RADWIN 5000 JET

### 5.3 Conducted emissions test according to § 15.207, RSS-Gen § 7.2.4

Method of measurement      ANSI C63.10 § 6.2  
 Ambient Temperature    23<sup>0</sup> C      Relative Humidity      52%      Air Pressure      1008 hPa

Frequency, MHz	Limit dB (µV)	
	QP	AVRG
0.15 - 0.5	66 - 56*	56 - 46*
0.5 - 5	56	46
5 - 30	60	50

\* Decreases with the logarithm of the frequency.

#### TEST PROCEDURE

EUT was placed on a wooden table in a shielded chamber at a height of 80 cm from the floor and 40 cm from the vertical reference plane. The measurements were performed at mains terminals by means of LISN, connected to spectrum analyzer. The measurements were made with quasi-peak and average (CISPR) detectors. The position of the EUT cables was varied to determine maximum emission level.

#### TEST RESULT:

Not required. PoE DC power option only.

#### TEST EQUIPMENT USED:

12	13	14			
----	----	----	--	--	--

**Test report No:** 9412327172/1

Page 24 of 75 Pages

**Title:** 5.8 GHz Smart Antenna Outdoor Radio Device

**Model:** RADWIN 2000 JET/RADWIN 5000 JET

## APPENDIX A      Photographs

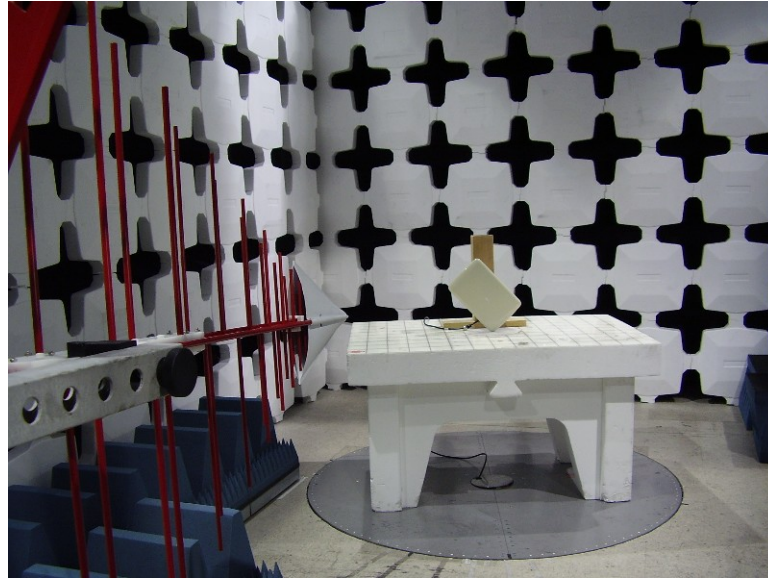

**Photo 1. Radiated emission test setup.**

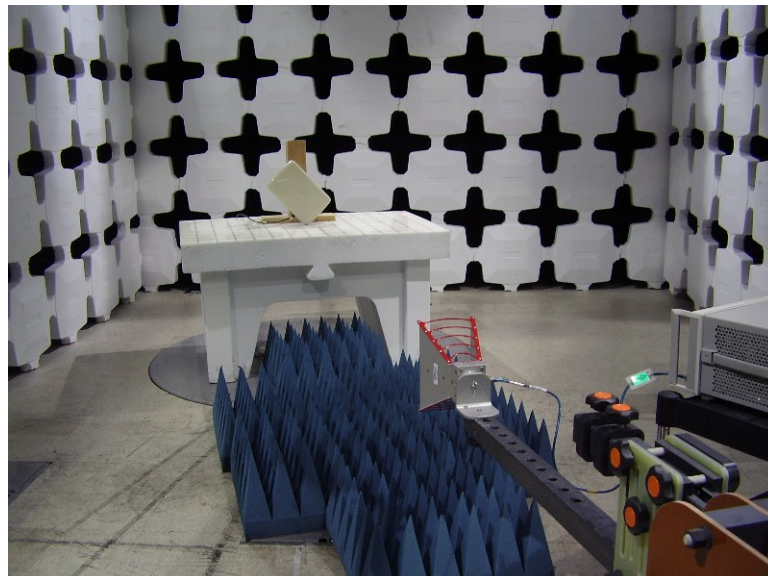

**Photo 2. Radiated emission test setup.**



**Test report No:** 9412327172/1

Page 25 of 75 Pages

**Title:** 5.8 GHz Smart Antenna Outdoor Radio Device

**Model:** RADWIN 2000 JET/RADWIN 5000 JET

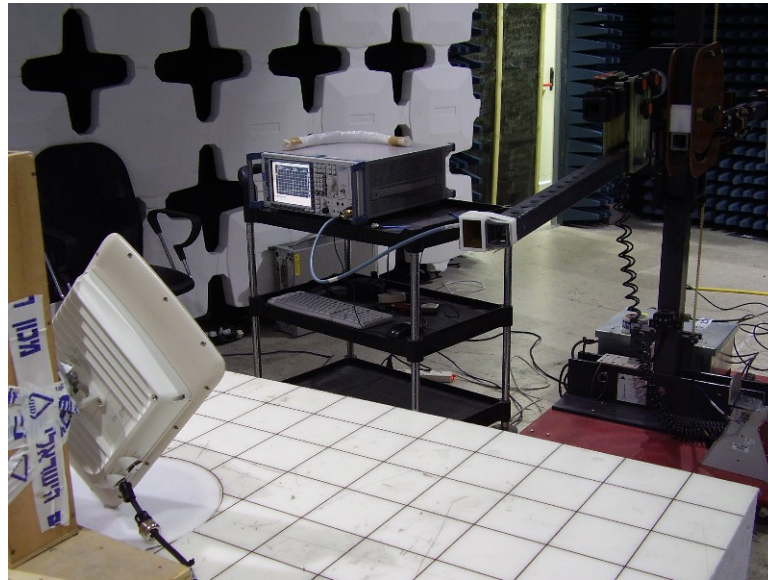

**Photo 3. Radiated emission test setup at 1m test distance.**



**Photo 4. Radiated emission test setup with Loop antenna.**

**Test report No: 9412327172/1****Page 26 of 75 Pages****Title: 5.8 GHz Smart Antenna Outdoor Radio Device****Model: RADWIN 2000 JET/RADWIN 5000 JET****APPENDIX B Test equipment used****Test equipment used**

No	Description	Manufacturer information			Due Calibration date
		Name	Model	Serial No	
1	MXE EMI Receiver 20 Hz -26.5 GHz	Agilent	N9038A	SII 650114	February 2016
2	EXA Signal Analyzer 10 Hz - 26.5 GHz	Agilent	N9010A	MY51250920	April 2016
3	Attenuators 10, 3 dB DC – 18 GHz	M/A-COM	2082	6143, 6148	June 2015
4	Power splitter 1.7 – 9.0 GHz	Mini-Circuits	ZN2PD-9G-S+	SF900801038	May 2015
5	Cable RF 1m	Huber-Suhner	Sucoflex 104	21324/4PE	October 2015
6	EPM Series Power Meter	HP	E4418A	US38261895	May 2015
7	E-Series Avg. Power Sensor 10 MHz – 6.0 GHz	Agilent	E9301A	MY41498740	May 2015
8	Double Ridged Guide Antenna 0.75 – 18 GHz	ETS-Lindgren	3115	00143138	September 2015
9	Broadband Horn antenna 15 – 40 GHz	Schwarzbeck Mess-Electronik	BBHA 9170	9170-341	January 2016
10	Antenna Biconilog 26 – 6000 MHz	ETS-Lindgren	31142D	0146490	December 2015
11	Spectrum analyzer 20 Hz-40 GHz	Rohde&Schwarz	ESU 40	100168	November 2015
12	EMI Receiver 9 kHz-6.5 GHz	HP	8546A+85460A	SII 4068	May 2015
13	LISN 9 kHz – 30 MHz	FCC	LISN 250-32-4-16	SII5023	October 2015
14	Transient limiter 0.009-200 MHz	HP	11947A	3107105	August 2015
15	Cable RF 4m	Huber-Suhner	Sucoflex 104PE	21329/4PE	October 2015
16	Cable RF 1.0m	ENP Connectivity Solutions	X116LCX10040	10-11-002	October 2015
17	Active Loop antenna 1.0 kHz – 30 MHz	ETS-Lindgren	6507	00144641	January 2016

**Test report No:** 9412327172/1

Page 27 of 75 Pages

**Title:** 5.8 GHz Smart Antenna Outdoor Radio Device**Model:** RADWIN 2000 JET/RADWIN 5000 JET**Cable Loss (Mast 6 m set cable.)**

Point	Frequency (MHz)	Cable Loss (dB)	Point	Frequency (MHz)	Cable Loss (dB)
1	30	0.3	21	1000	2.5
2	50	0.4	22	1100	2.6
3	100	0.6	23	1200	2.8
4	150	0.8	24	1300	2.9
5	200	1.0	25	1400	3.1
6	250	1.1	26	1500	3.2
7	300	1.2	27	1600	3.3
8	350	1.3	28	1700	3.5
9	400	1.5	29	1800	3.6
10	450	1.6	30	1900	3.7
11	500	1.7	31	2000	3.9
12	550	1.8	32	2100	4.0
13	600	1.9	33	2200	4.1
14	650	1.9	34	2300	4.2
15	700	2.0	35	2400	4.4
16	750	2.1	36	2500	4.6
17	800	2.1	37	2600	4.7
18	850	2.2	38	2700	4.8
19	900	2.3	39	2800	4.9
20	950	2.4	40	2900	5.0

**Test report No:** 9412327172/1

Page 28 of 75 Pages

**Title:** 5.8 GHz Smart Antenna Outdoor Radio Device**Model:** RADWIN 2000 JET/RADWIN 5000 JET

**Antenna factor**  
**Biconilog Antenna, ETS-Lindgren mod. 31142D, S/N: 0146490 3m calibration.**

No.	f / MHz	AF / dB/m	f / MHz	AF / dB/m	f / MHz	AF / dB/m
1	30	18.7	250	12.0	2750	31.0
2	35	15.7	300	13.8	3000	31.2
3	40	12.9	400	16.2	3250	32.7
4	45	10.6	500	18.6	3500	34.5
5	50	9.0	600	20.2	3750	34.3
6	60	7.3	700	21.8	4000	34.5
7	70	7.7	800	22.9	4250	35.3
8	80	8.2	900	24.1	4500	35.5
9	90	9.2	1000	24.8	4750	36.1
10	100	9.4	1250	26.9	5000	37.4
11	120	8.5	1500	30.2	5250	38.4
12	140	8.5	1750	28.5	5000	39.9
13	160	9.1	2000	28.9	5750	38.2
14	180	10.5	2250	29.8	6000	39.1
15	200	10.9	2500	32.5		

**Test report No:** 9412327172/1

Page 29 of 75 Pages

**Title:** 5.8 GHz Smart Antenna Outdoor Radio Device**Model:** RADWIN 2000 JET/RADWIN 5000 JET**Antenna Factor****Double Ridged Guide Antenna mfr ETS-Lindgren model 3115 1m calibration**

Point	Frequency (MHz)	Antenna Factor (dB/m)
1	1000	23.7
2	1500	25.5
3	2000	28.5
4	2500	28.1
5	3000	29.6
6	3500	31.1
7	4000	32.5
8	4500	32.5
9	5000	33.5
10	5500	34.7
11	6000	36.1
12	6500	36.5
13	7000	37.3
14	7500	38.0
15	8000	37.3
16	8500	37.9
17	9000	38.1
18	9500	38.5
19	10000	38.7
20	10500	38.8
21	11000	38.6
22	11500	38.8
23	12000	38.9
24	12500	39.3
25	13000	40.2
26	13500	40.6
27	14000	40.6
28	14500	40.4
29	15000	39.6
30	15500	39.5
31	16000	39.8
32	16500	40.4
33	17000	41.3
34	17500	42.6
35	18000	43.2

**Cable Loss****Type: Sucoflex 104PE; Ser.No.21329/4PE; 4 m length**

Point	Frequency (GHz)	Cable Loss (dB)
0	0.0-1.8	1.67
1	1.8 – 3.6	2.39
2	3.6 – 5.4	3.04
3	5.4-7.2	3.58
4	7.2-9.0	4.06
5	9.0-10.8	4.49
6	10.8-12.6	4.91
7	12.6-14.4	5.31
8	14.4-16.2	5.66
9	16.2-18.00	6.01

**Test report No:** 9412327172/1

Page 30 of 75 Pages

**Title:** 5.8 GHz Smart Antenna Outdoor Radio Device**Model:** RADWIN 2000 JET/RADWIN 5000 JET**Antenna Factor****Broadband Horn Antenna model BBHA 9170 1m calibration**

Point	Frequency (GHz)	Antenna Factor (dB/m)
1	15.0	38.5
2	16.0	37.7
3	17.0	38.1
4	18.0	37.9
5	19.0	38.0
6	20.0	38.0
7	21.0	37.9
8	22.0	38.2
9	23.0	39.6
10	24.0	39.6
11	25.0	39.3
12	26.0	39.5
13	27.0	39.6
14	28.0	39.6
15	30.0	40.1
16	32.0	41.2
17	34.0	41.5
18	35.0	41.9
19	36.0	42.2
20	38.0	43.8
21	40.0	43.2

**Antenna Factor****Antenna Loop MFR ETS Lindgren, Type/Model 6507, S/N: 00144641**

No.	Frequency MHz	Magnetic antenna factor, dBS/m	Electric antenna factor, dB/m
1	9	-21.5	30.0
2	10	-22.0	29.5
3	20	-27.7	23.8
4	50	-32.2	19.4
5	75	-33.0	18.5
6	100	-33.4	18.2
7	150	-33.6	17.9
8	250	-33.7	17.9
9	500	-33.8	17.8
10	750	-33.8	17.7
11	1000	-33.8	17.7
12	2000	-33.7	17.9
13	3000	-33.8	17.8
14	4000	-34.0	17.5
15	5000	-34.3	17.2
16	10000	-35.2	16.4
17	15000	-35.8	15.8
18	20000	-36.0	15.6
19	25000	-36.2	15.3
20	30000	-36.4	15.2



Test report No: 9412327172/1

Page 31 of 75 Pages

Title: 5.8 GHz Smart Antenna Outdoor Radio Device

Model: RADWIN 2000 JET/RADWIN 5000 JET

APPENDIX C Plot test results.

6 dB DTS BW results.

Method of measurement	558074 D01 DTS Meas Guidance. Section 8.2					
Operating Frequency Range	5730– 5845 MHz					
Detector used	Peak					
Resolution bandwidth	>1 % OBW					
Video bandwidth	> 3 x RBW.					
Trace mode	Max Hold.					
Sweep time:	Auto couple.					
Type of modulation:	64QAM					
Ambient Temperature	24 <sup>0</sup> C	Relative Humidity	51%	Air Pressure	1009 hPa	

5 MHz OBW

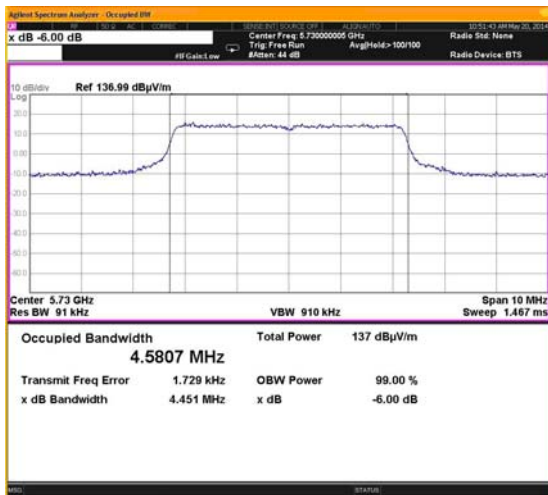

Plot # 1

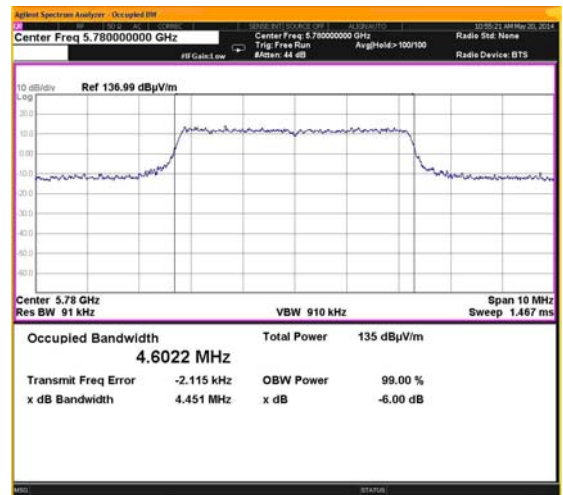

Plot # 2

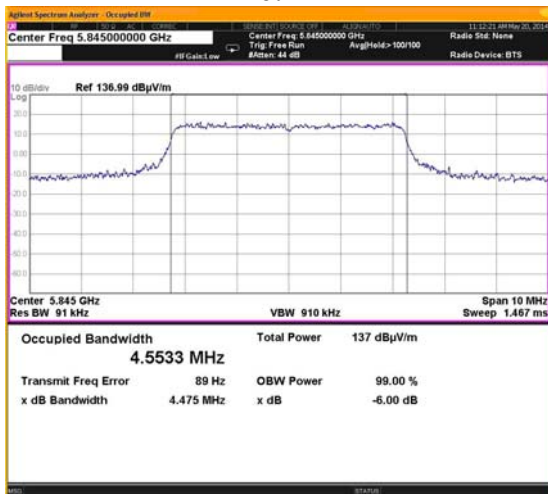

Plot # 3



Test report No: 9412327172/1

Page 32 of 75 Pages

Title: 5.8 GHz Smart Antenna Outdoor Radio Device

Model: RADWIN 2000 JET/RADWIN 5000 JET

10 MHz OBW

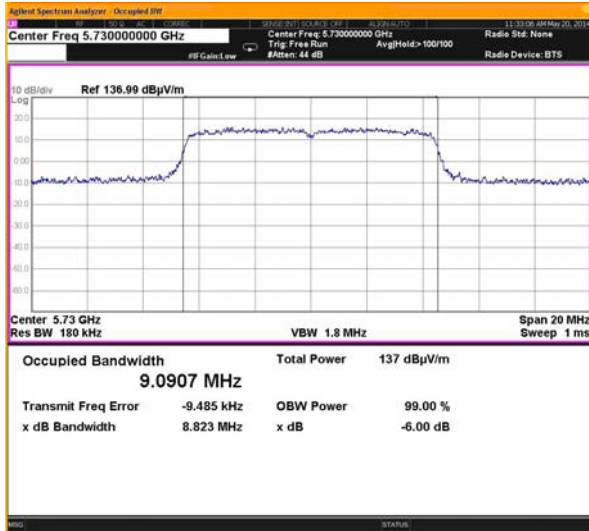

Plot # 4

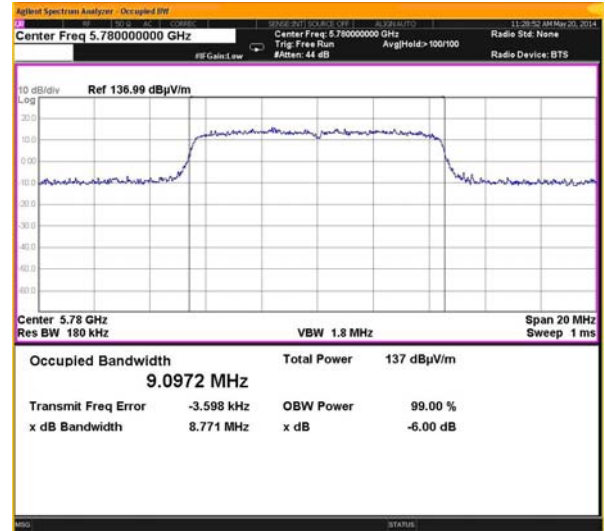

Plot # 5

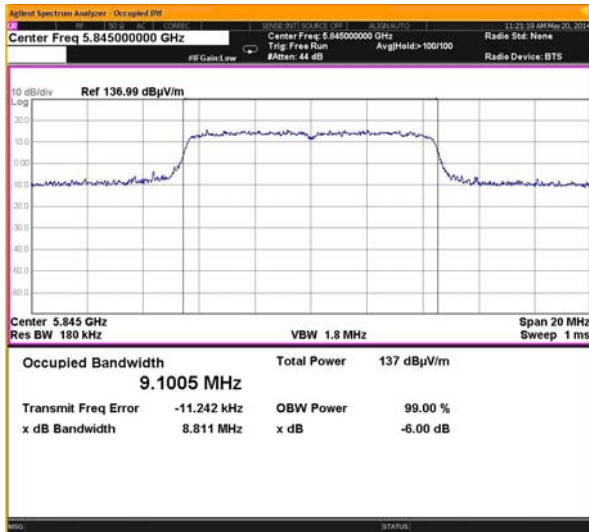

Plot # 6





Test report No: 9412327172/1

Page 33 of 75 Pages

Title: 5.8 GHz Smart Antenna Outdoor Radio Device

Model: RADWIN 2000 JET/RADWIN 5000 JET

20 MHz OBW

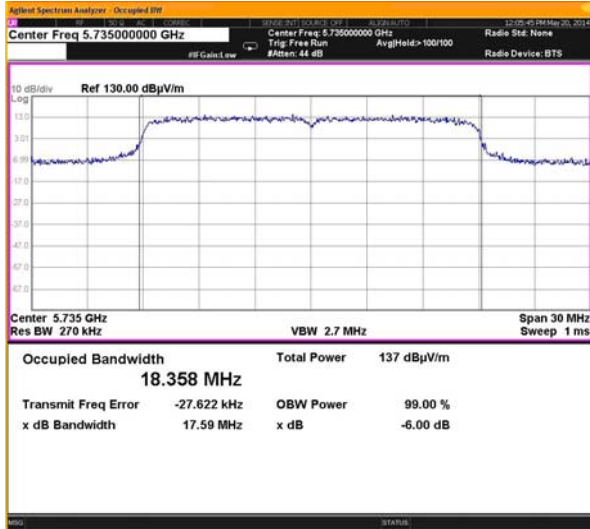

Plot # 7

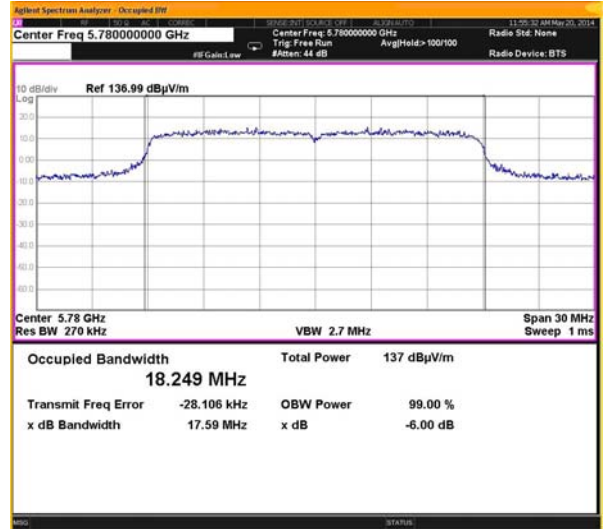

Plot # 8

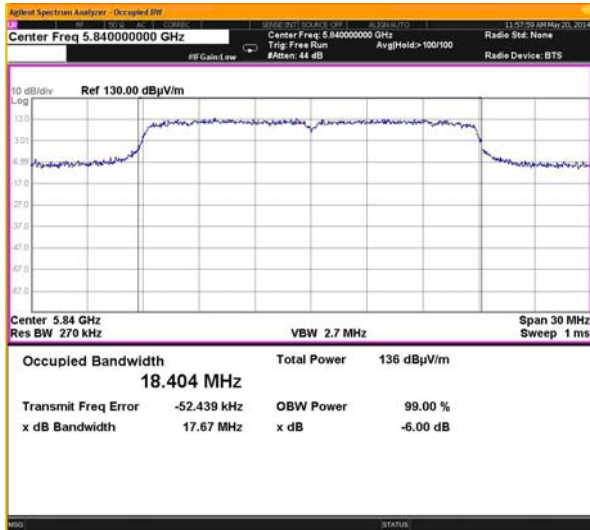

Plot # 9



Test report No: 9412327172/1

Page 34 of 75 Pages

Title: 5.8 GHz Smart Antenna Outdoor Radio Device

Model: RADWIN 2000 JET/RADWIN 5000 JET

40 MHz OBW

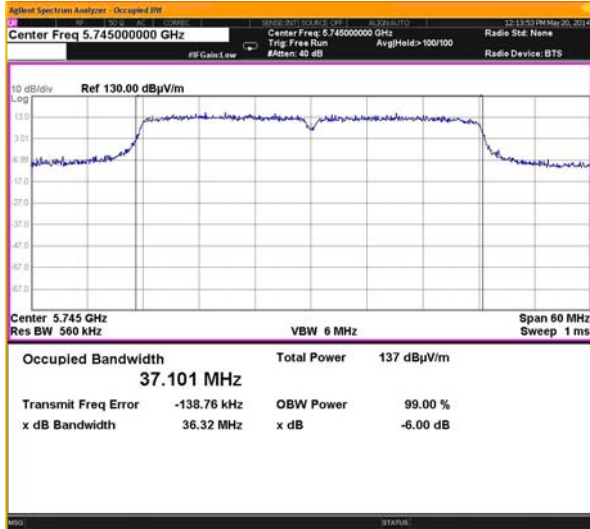

Plot # 10

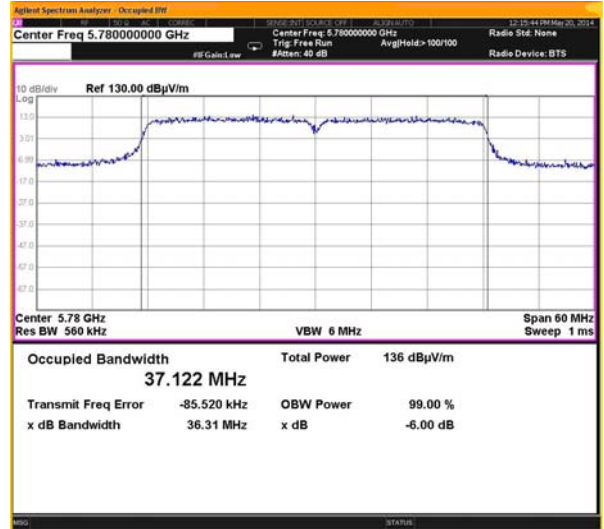

Plot # 11

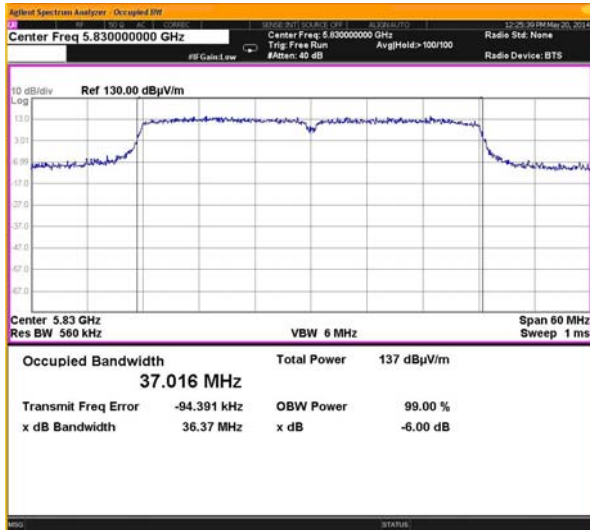

Plot # 12



**Test report No: 9412327172/1**

**Page 35 of 75 Pages**

**Title: 5.8 GHz Smart Antenna Outdoor Radio Device**

**Model: RADWIN 2000 JET/RADWIN 5000 JET**



Plot # 13. Tx on time.

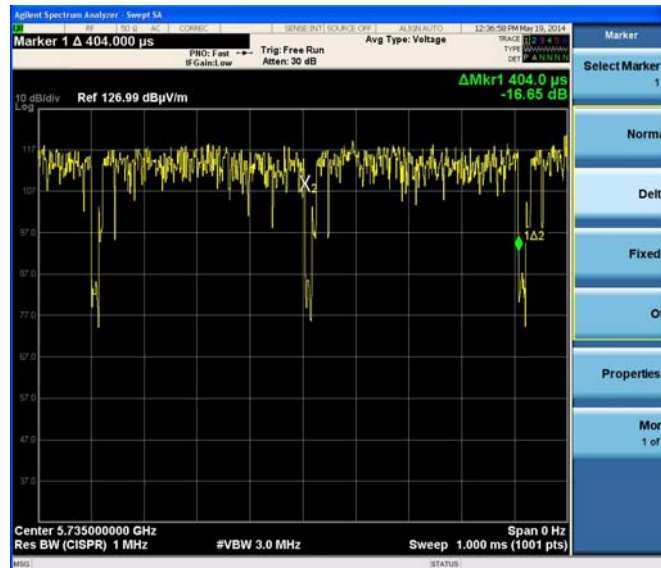

Plot # 14. Tx on + off time.



Test report No: 9412327172/1

Page 36 of 75 Pages

Title: 5.8 GHz Smart Antenna Outdoor Radio Device

Model: RADWIN 2000 JET/RADWIN 5000 JET

**Chain 1. Output power test.**

Method of measurement	558074 D01 DTS Meas Guidance. section 9.1					
Operating Frequency Range	5730– 5845 MHz					
Detector used	Peak					
Resolution bandwidth	1 MHz					
Video bandwidth	> RBW.					
Trace mode	Max Hold.					
Type of modulation:	64QAM					
Ambient Temperature	24 <sup>0</sup> C	Relative Humidity	47%	Air Pressure	1007 hPa	

5 MHz OBW

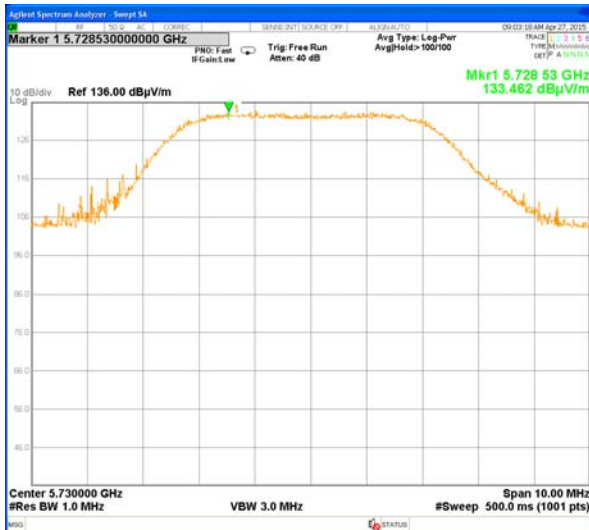

Plot # 15

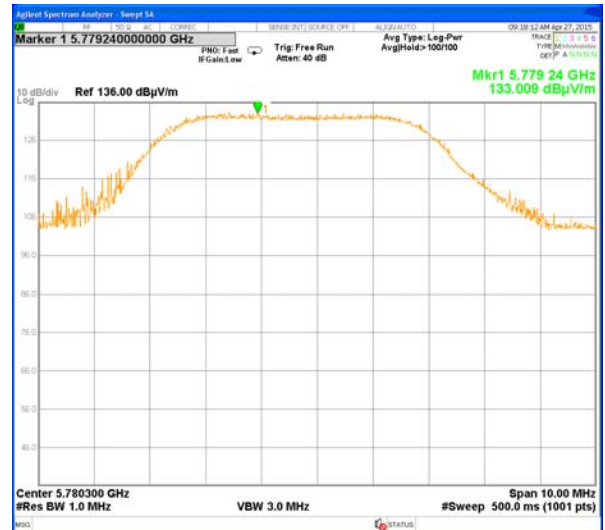

Plot # 16

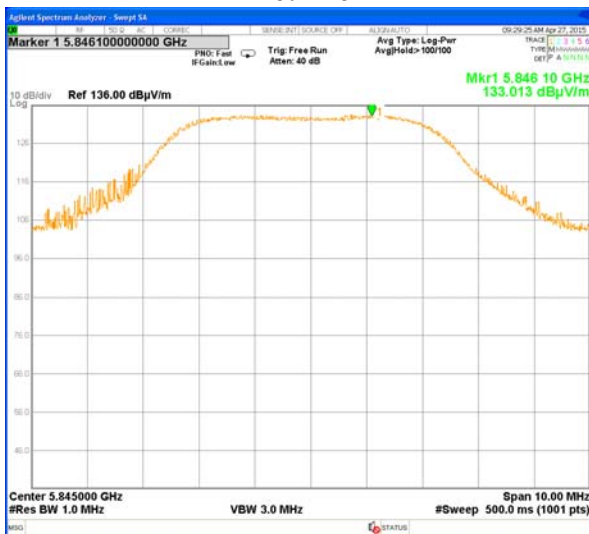

Plot # 17



Test report No: 9412327172/1

Page 37 of 75 Pages

Title: 5.8 GHz Smart Antenna Outdoor Radio Device

Model: RADWIN 2000 JET/RADWIN 5000 JET

10 MHz OBW

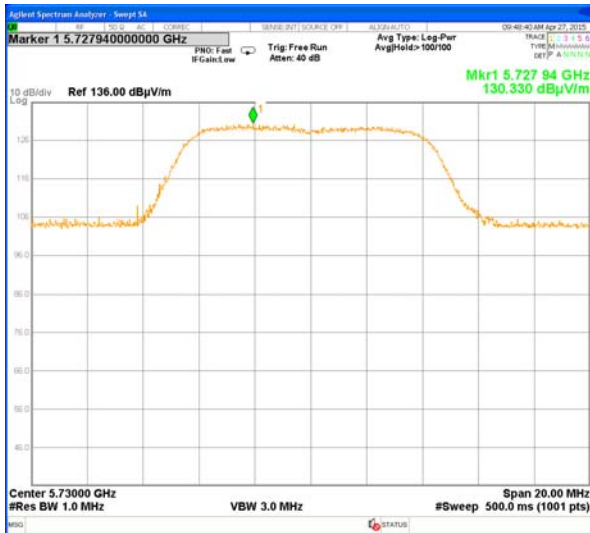

Plot # 18

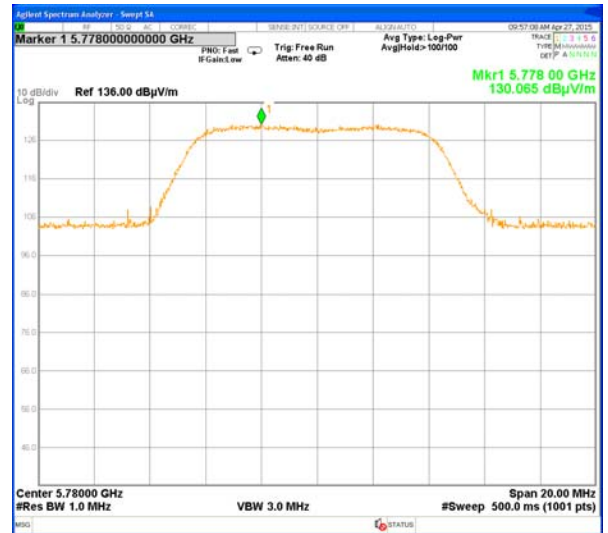

Plot # 19



Plot # 20



Test report No: 9412327172/1

Page 38 of 75 Pages

Title: 5.8 GHz Smart Antenna Outdoor Radio Device

Model: RADWIN 2000 JET/RADWIN 5000 JET

20 MHz OBW

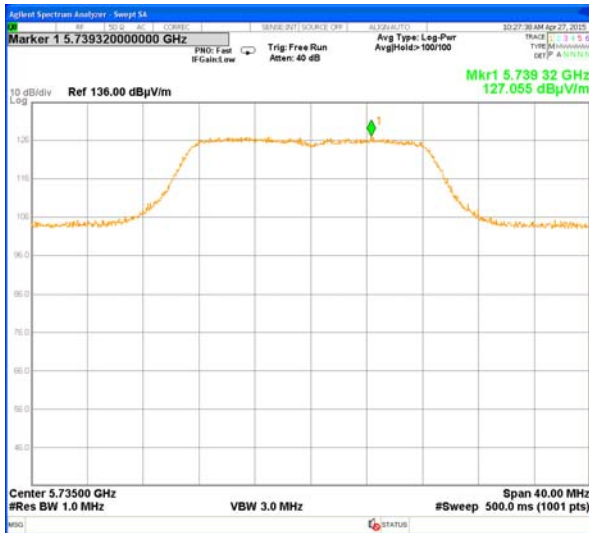

Plot # 21



Plot # 22

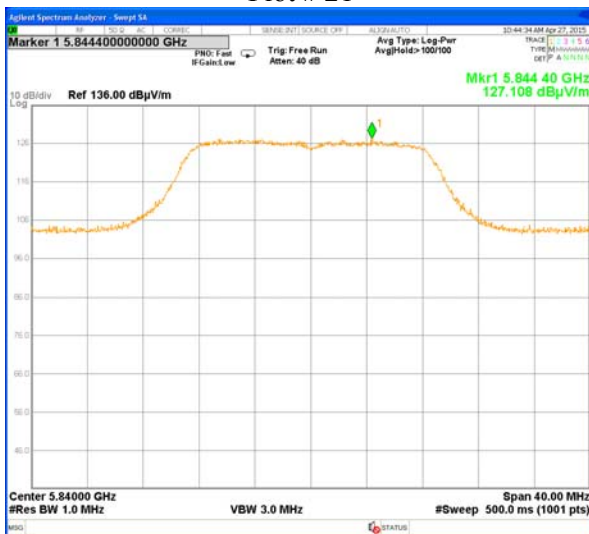

Plot # 23



Test report No: 9412327172/1

Page 39 of 75 Pages

Title: 5.8 GHz Smart Antenna Outdoor Radio Device

Model: RADWIN 2000 JET/RADWIN 5000 JET

40 MHz OBW



Plot # 24



Plot # 25

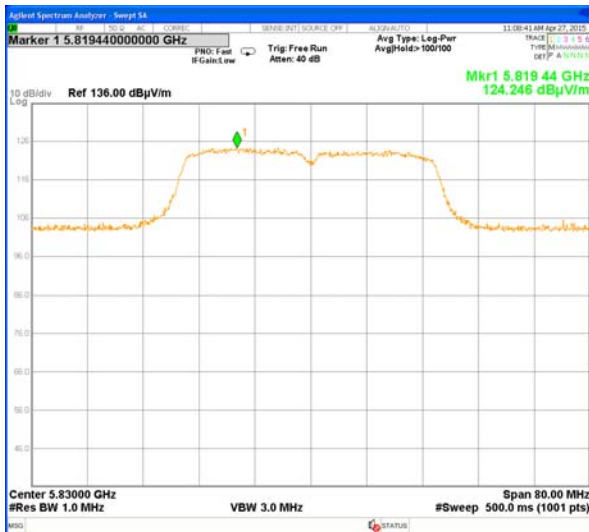

Plot # 26



Test report No: 9412327172/1

Page 40 of 75 Pages

Title: 5.8 GHz Smart Antenna Outdoor Radio Device

Model: RADWIN 2000 JET/RADWIN 5000 JET

**Chain 2. Output power test.**

Method of measurement	558074 D01 DTS Meas Guidance. section 9.1						
Operating Frequency Range	5730– 5845 MHz						
Detector used	Peak						
Resolution bandwidth	1 MHz						
Video bandwidth	> RBW.						
Trace mode	Max Hold.						
Type of modulation:	64QAM						
Ambient Temperature	24 <sup>0</sup> C	Relative Humidity	47%	Air Pressure	1007 hPa		

5 MHz OBW

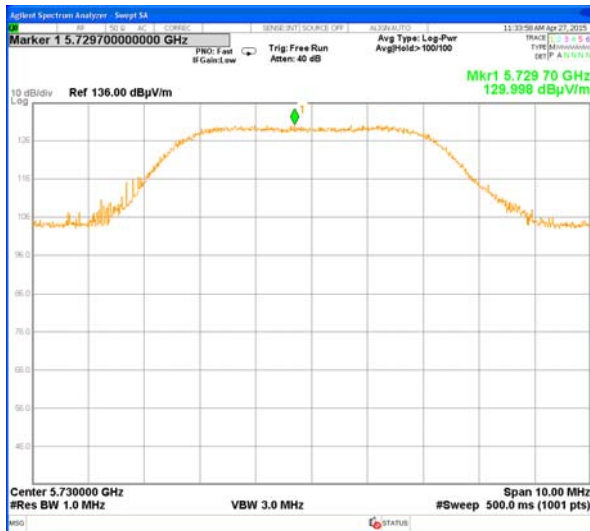

Plot # 27



Plot # 28



Plot # 29





Test report No: 9412327172/1

Page 41 of 75 Pages

Title: 5.8 GHz Smart Antenna Outdoor Radio Device

Model: RADWIN 2000 JET/RADWIN 5000 JET

10 MHz OBW



Plot # 30



Plot # 31

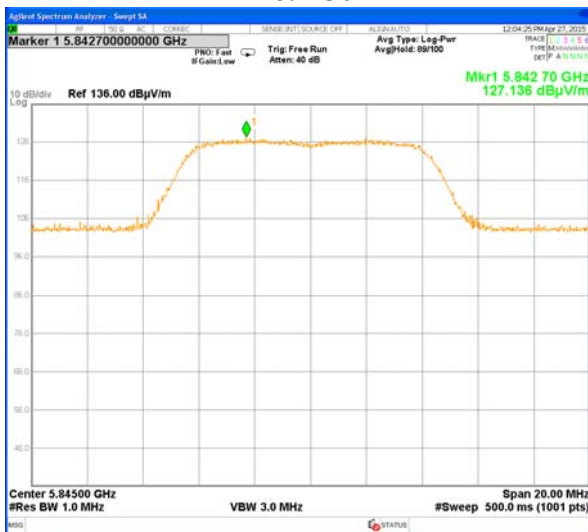

Plot # 32



Test report No: 9412327172/1

Page 42 of 75 Pages

Title: 5.8 GHz Smart Antenna Outdoor Radio Device

Model: RADWIN 2000 JET/RADWIN 5000 JET

20 MHz OBW

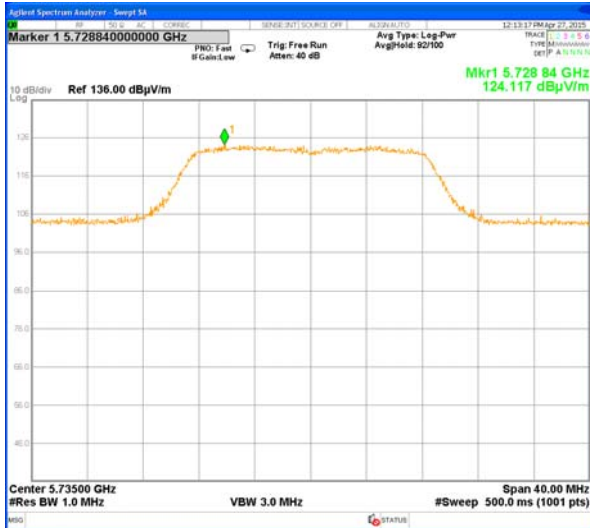

Plot # 33



Plot # 34

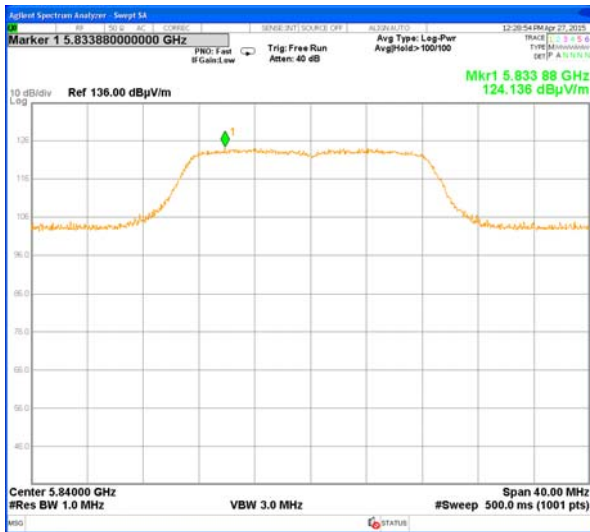

Plot # 35



Test report No: 9412327172/1

Page 43 of 75 Pages

Title: 5.8 GHz Smart Antenna Outdoor Radio Device

Model: RADWIN 2000 JET/RADWIN 5000 JET

40 MHz OBW



Plot # 36



Plot # 37



Plot # 38



Test report No: 9412327172/1

Page 44 of 75 Pages

Title: 5.8 GHz Smart Antenna Outdoor Radio Device

Model: RADWIN 2000 JET/RADWIN 5000 JET

**Chain 3. Output power test.**

Method of measurement	558074 D01 DTS Meas Guidance. section 9.1					
Operating Frequency Range	5730– 5845 MHz					
Detector used	Peak					
Resolution bandwidth	1 MHz					
Video bandwidth	> RBW.					
Trace mode	Max Hold.					
Type of modulation:	64QAM					
Ambient Temperature	24 <sup>0</sup> C	Relative Humidity	47%	Air Pressure	1007 hPa	

5 MHz OBW.

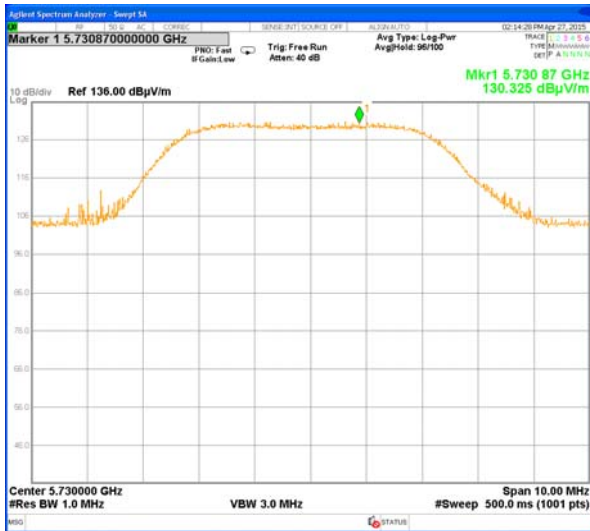

Plot # 39

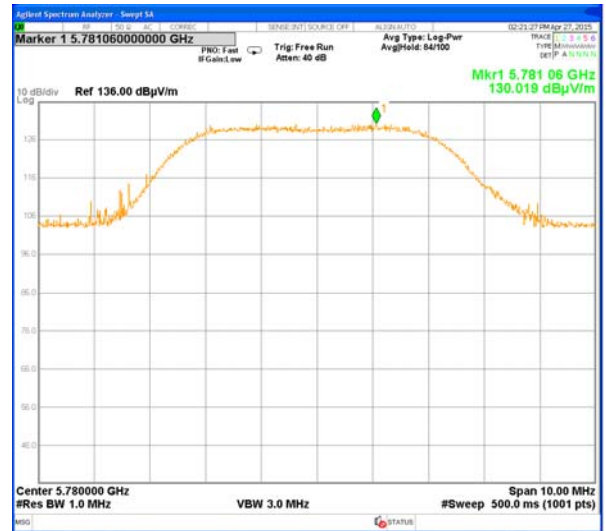

Plot # 40



Plot # 41



Test report No: 9412327172/1

Page 45 of 75 Pages

Title: 5.8 GHz Smart Antenna Outdoor Radio Device

Model: RADWIN 2000 JET/RADWIN 5000 JET

10 MHz OBW.

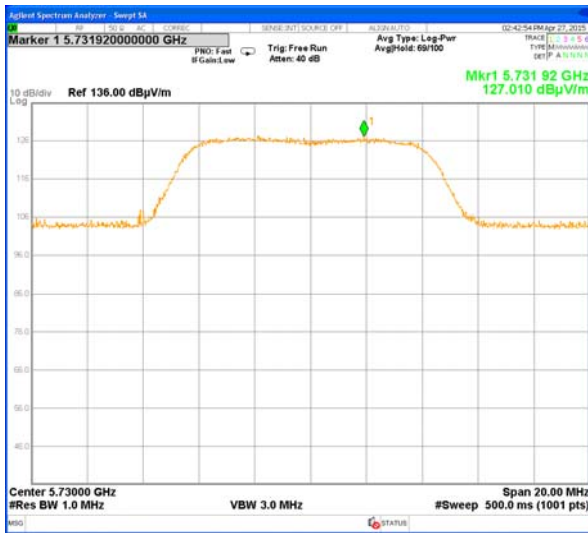

Plot # 42

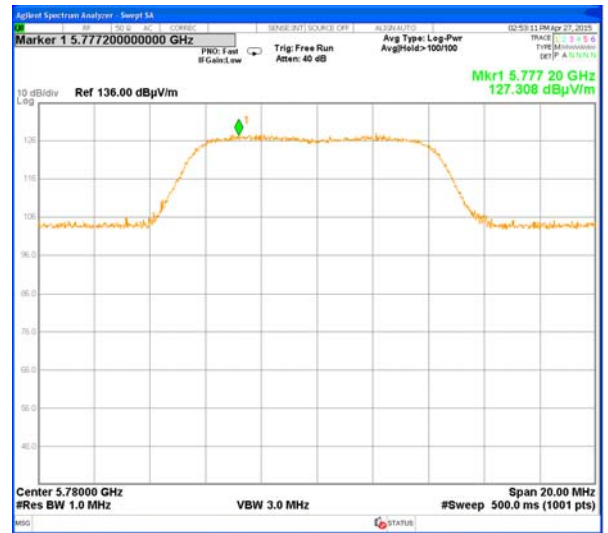

Plot # 43

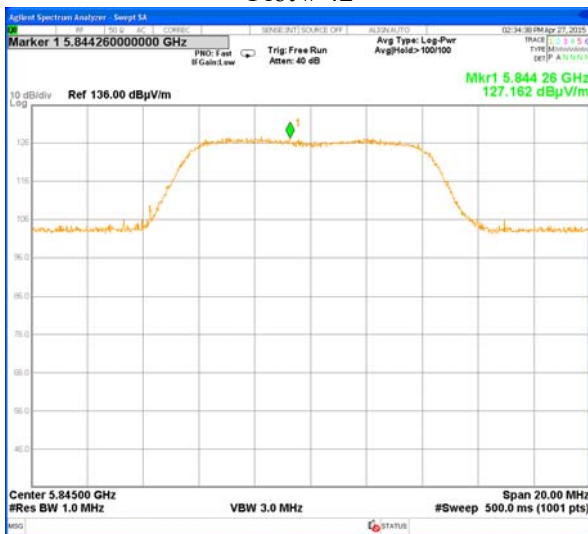

Plot # 44



Test report No: 9412327172/1

Page 46 of 75 Pages

Title: 5.8 GHz Smart Antenna Outdoor Radio Device

Model: RADWIN 2000 JET/RADWIN 5000 JET

20 MHz OBW.

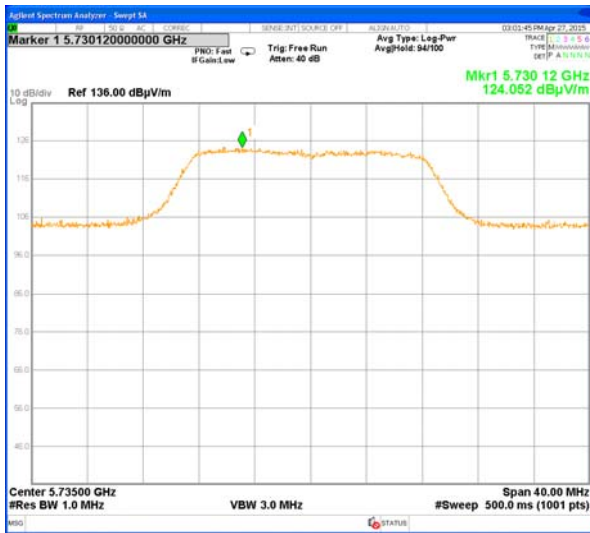

Plot # 45

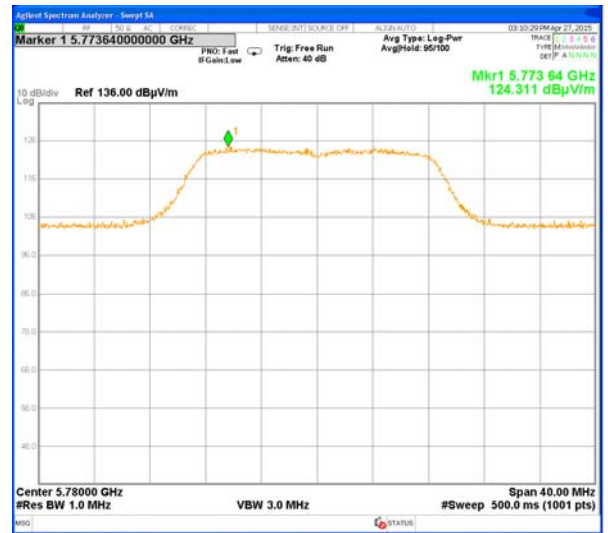

Plot # 46

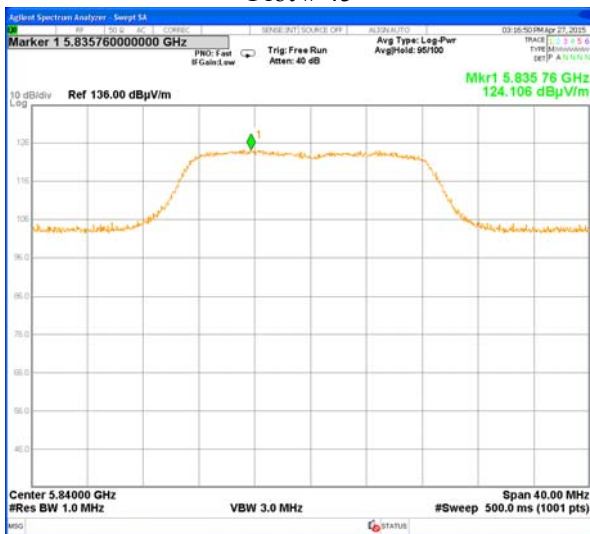

Plot # 47



Test report No: 9412327172/1

Page 47 of 75 Pages

Title: 5.8 GHz Smart Antenna Outdoor Radio Device

Model: RADWIN 2000 JET/RADWIN 5000 JET

40 MHz OBW.

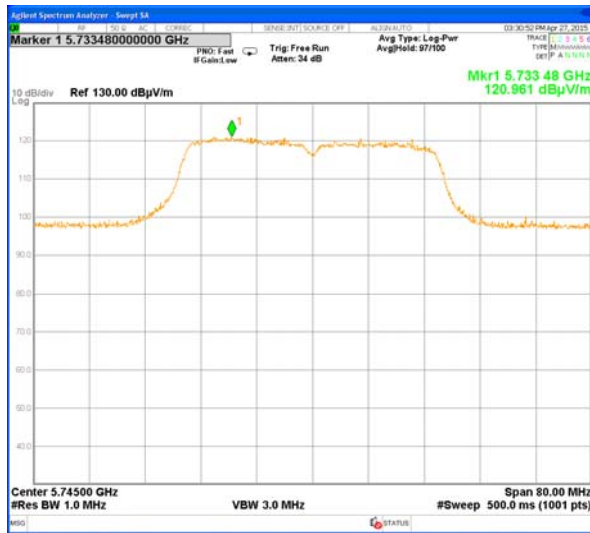

Plot # 48

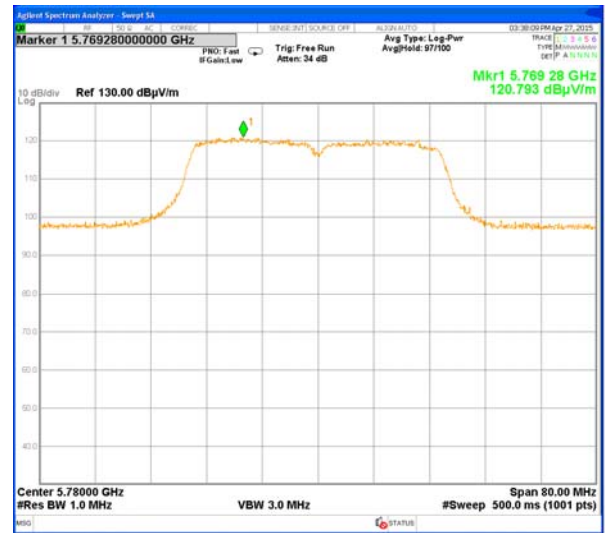

Plot # 49

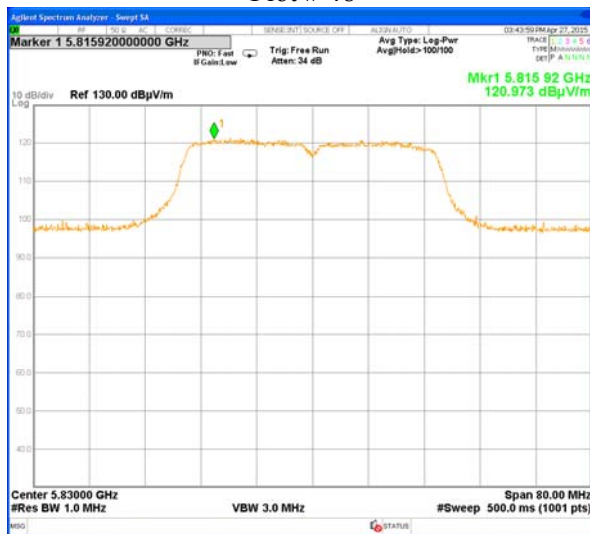

Plot # 50



Test report No: 9412327172/1

Page 48 of 75 Pages

Title: 5.8 GHz Smart Antenna Outdoor Radio Device

Model: RADWIN 2000 JET/RADWIN 5000 JET

**Chain 1. Power Spectral Density test.**

Method of measurement	558074 D01 DTS Meas Guidance. Section 10.2 (peak PSD)		
Operating Frequency Range	5730– 5845 MHz		
Detector used	Peak		
Resolution bandwidth	3 kHz		
Video bandwidth	> 3 x RBW.		
Trace mode	Max Hold.		
Type of modulation:	64QAM		
Ambient Temperature	24° C	Relative Humidity	47%
		Air Pressure	1007 hPa

5 MHz OBW.

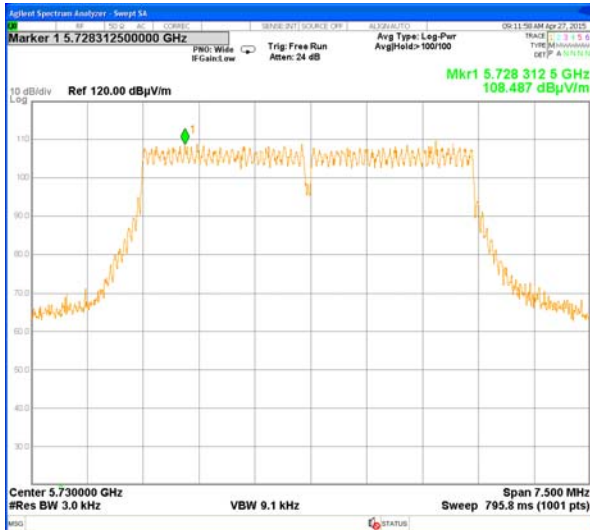

Plot # 51

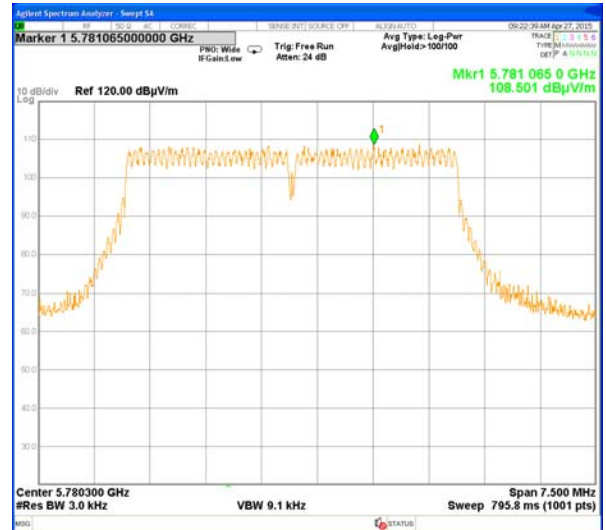

Plot # 52

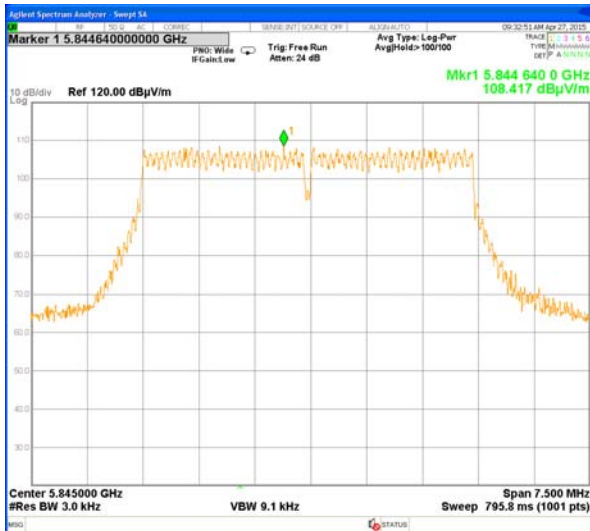

Plot # 53





Test report No: 9412327172/1

Page 49 of 75 Pages

Title: 5.8 GHz Smart Antenna Outdoor Radio Device

Model: RADWIN 2000 JET/RADWIN 5000 JET

10 MHz OBW

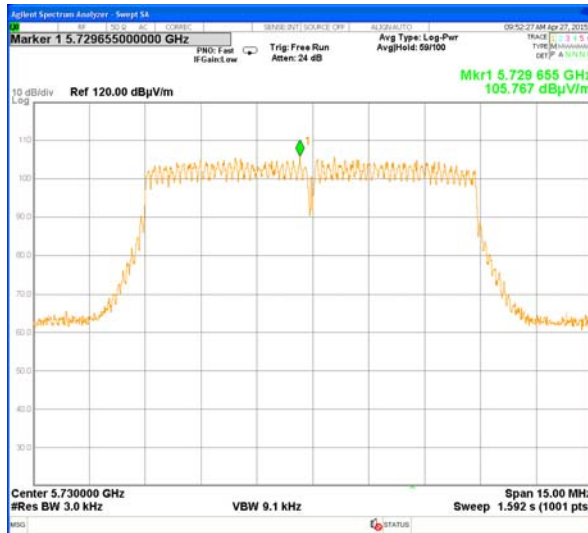

Plot # 54

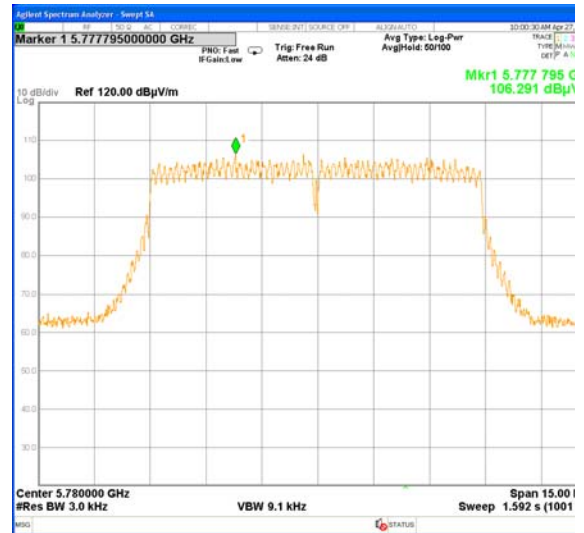

Plot # 55

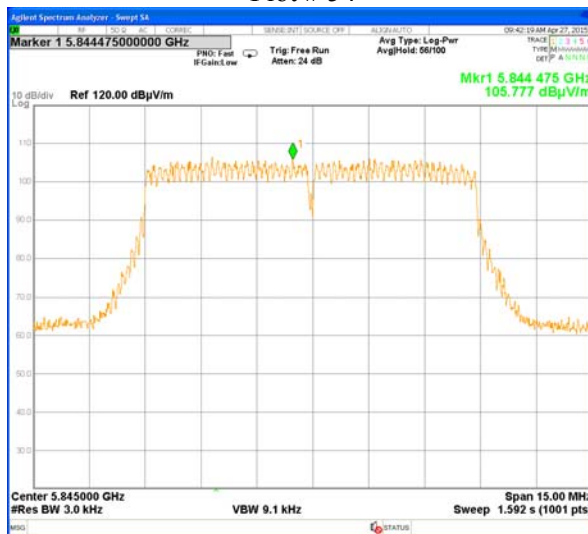

Plot # 56



Test report No: 9412327172/1

Page 50 of 75 Pages

Title: 5.8 GHz Smart Antenna Outdoor Radio Device

Model: RADWIN 2000 JET/RADWIN 5000 JET

20 MHz OBW.

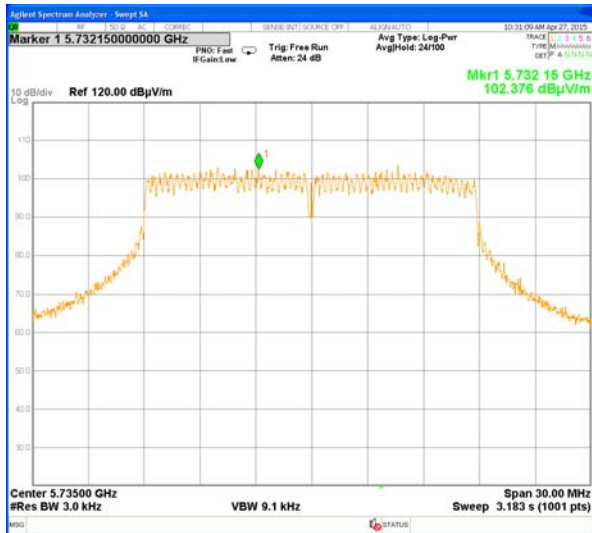

Plot # 57

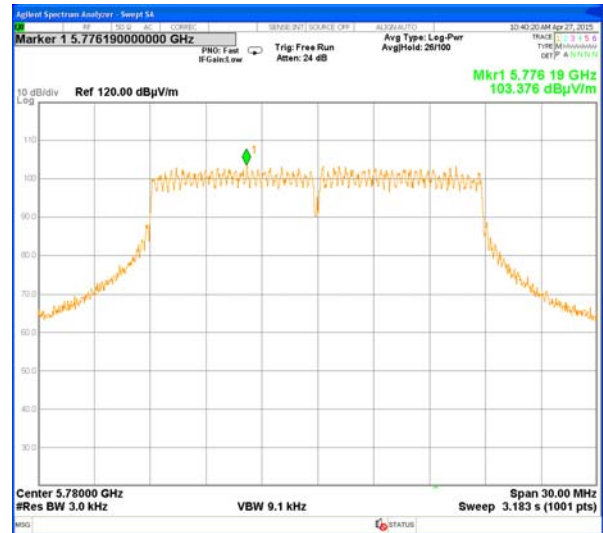

Plot # 58

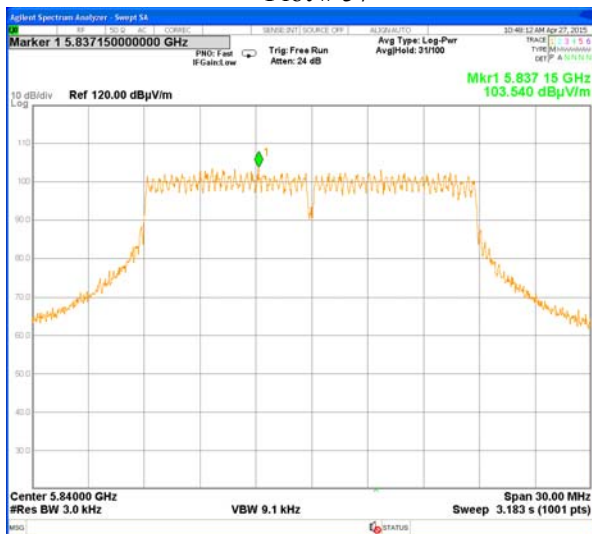

Plot # 59



Test report No: 9412327172/1

Page 51 of 75 Pages

Title: 5.8 GHz Smart Antenna Outdoor Radio Device

Model: RADWIN 2000 JET/RADWIN 5000 JET

40 MHz OBW.

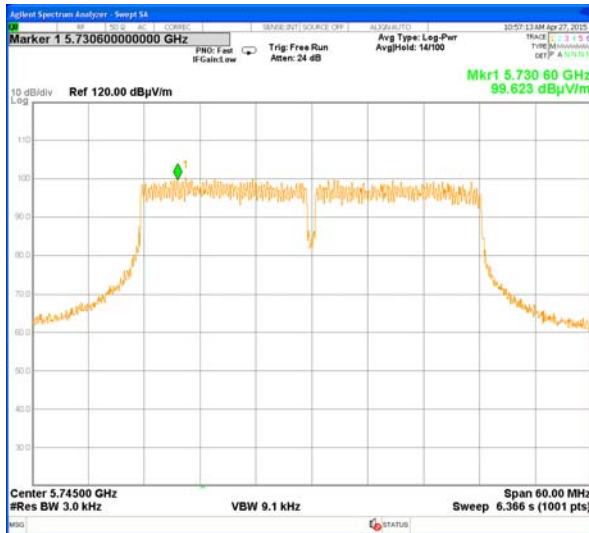

Plot # 60

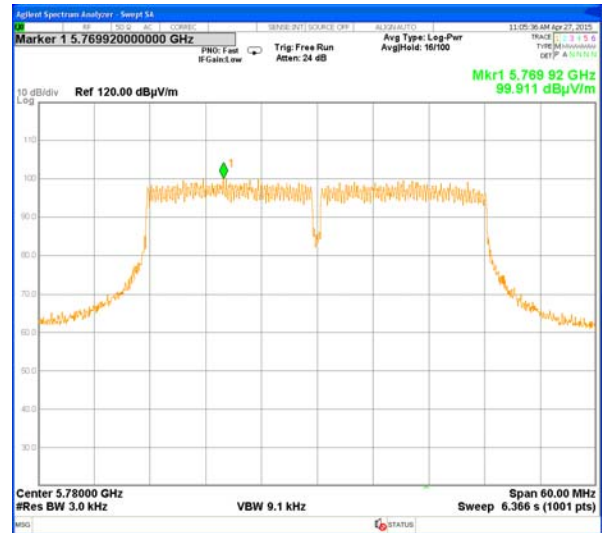

Plot # 61

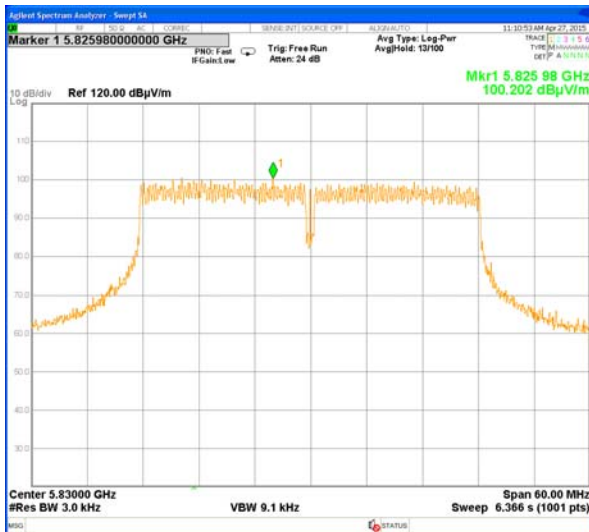

Plot # 62



Test report No: 9412327172/1

Page 52 of 75 Pages

Title: 5.8 GHz Smart Antenna Outdoor Radio Device

Model: RADWIN 2000 JET/RADWIN 5000 JET

Chain 2. Power Spectral Density test.

Method of measurement	558074 D01 DTS Meas Guidance. Section 10.2 (peak PSD)				
Operating Frequency Range	5730– 5845 MHz				
Detector used	Peak				
Resolution bandwidth	3 kHz				
Video bandwidth	> 3 x RBW.				
Trace mode	Max Hold.				
Type of modulation:	64QAM				
Ambient Temperature	24 <sup>0</sup> C	Relative Humidity	47%	Air Pressure	1007 hPa

5 MHz OBW option

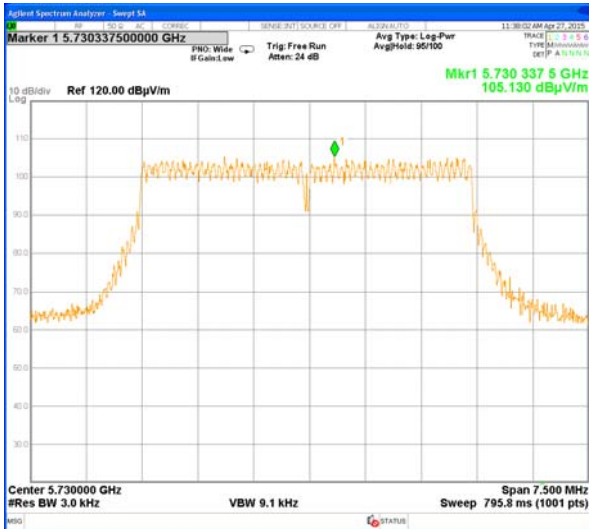

Plot # 63

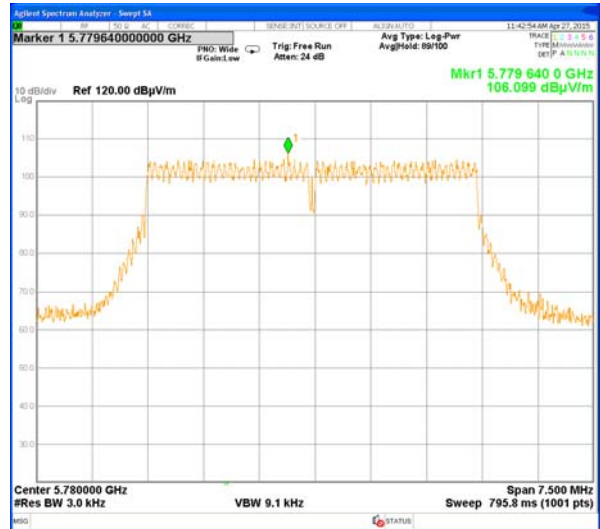

Plot # 64



Plot # 65



Test report No: 9412327172/1

Page 53 of 75 Pages

Title: 5.8 GHz Smart Antenna Outdoor Radio Device

Model: RADWIN 2000 JET/RADWIN 5000 JET

10 MHz OBW.

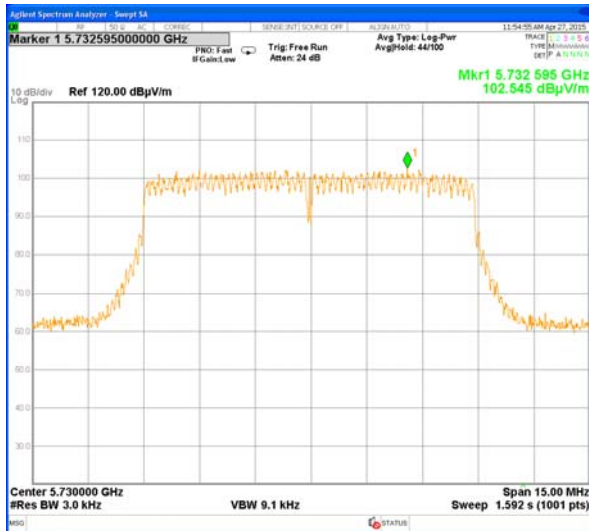

Plot # 66

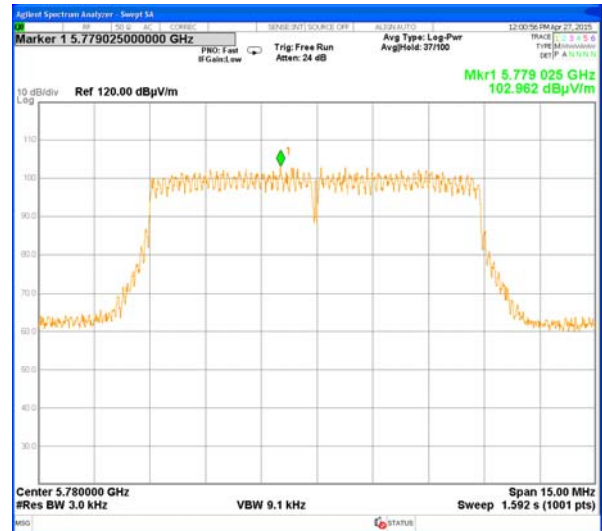

Plot # 67

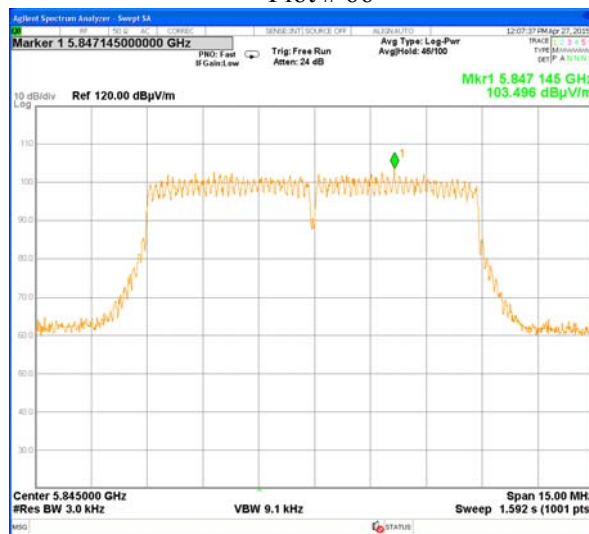

Plot # 68



Test report No: 9412327172/1

Page 54 of 75 Pages

Title: 5.8 GHz Smart Antenna Outdoor Radio Device

Model: RADWIN 2000 JET/RADWIN 5000 JET

20 MHz OBW.



Plot # 69

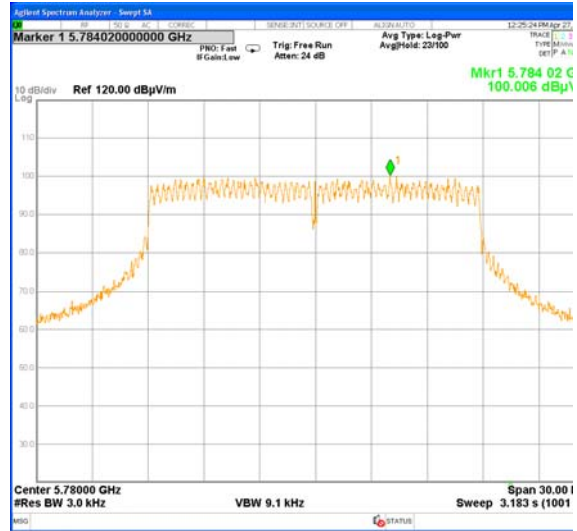

Plot # 70

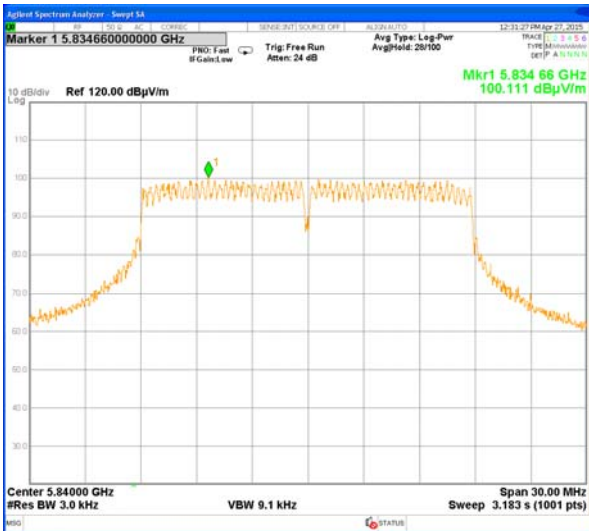

Plot # 71



Test report No: 9412327172/1

Page 55 of 75 Pages

Title: 5.8 GHz Smart Antenna Outdoor Radio Device

Model: RADWIN 2000 JET/RADWIN 5000 JET

40 MHz OBW.

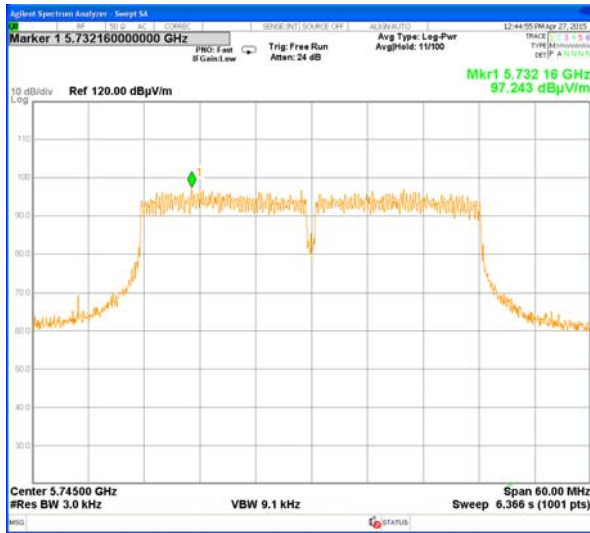

Plot # 72

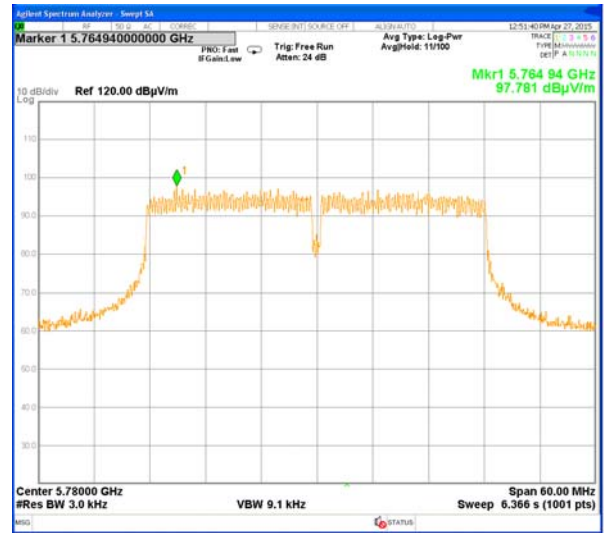

Plot # 73

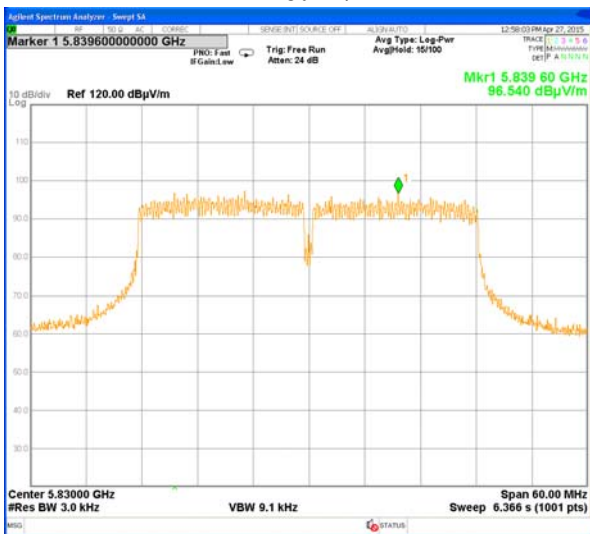

Plot # 74



Test report No: 9412327172/1

Page 56 of 75 Pages

Title: 5.8 GHz Smart Antenna Outdoor Radio Device

Model: RADWIN 2000 JET/RADWIN 5000 JET

**Chain 3. Power Spectral Density test.**

Method of measurement	558074 D01 DTS Meas Guidance. Section 10.2 (peak PSD)						
Operating Frequency Range	5730– 5845 MHz						
Detector used	Peak						
Resolution bandwidth	3 kHz						
Video bandwidth	> 3 x RBW.						
Trace mode	Max Hold.						
Type of modulation:	64QAM						
Ambient Temperature	24 <sup>0</sup> C	Relative Humidity	47%	Air Pressure	1007 hPa		

5 MHz OBW.

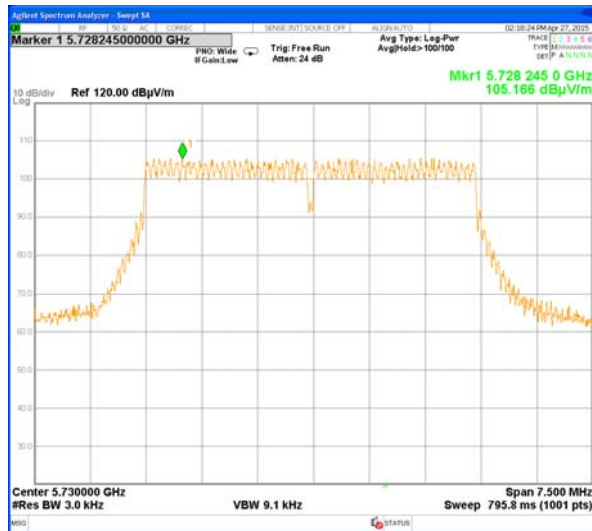

Plot # 75



Plot # 76

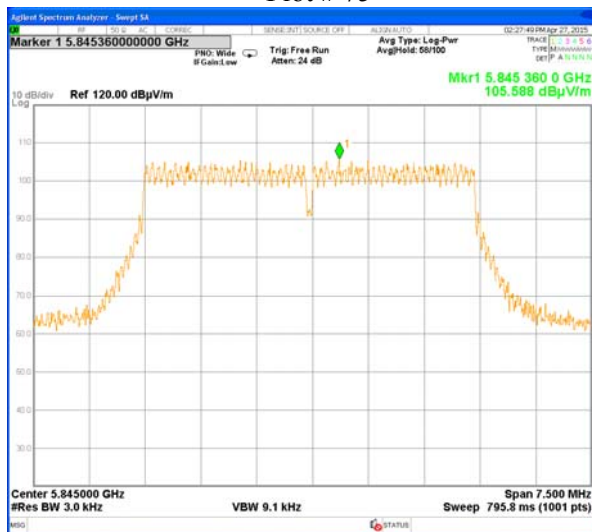

Plot # 77





Test report No: 9412327172/1

Page 57 of 75 Pages

Title: 5.8 GHz Smart Antenna Outdoor Radio Device

Model: RADWIN 2000 JET/RADWIN 5000 JET

10 MHz OBW.

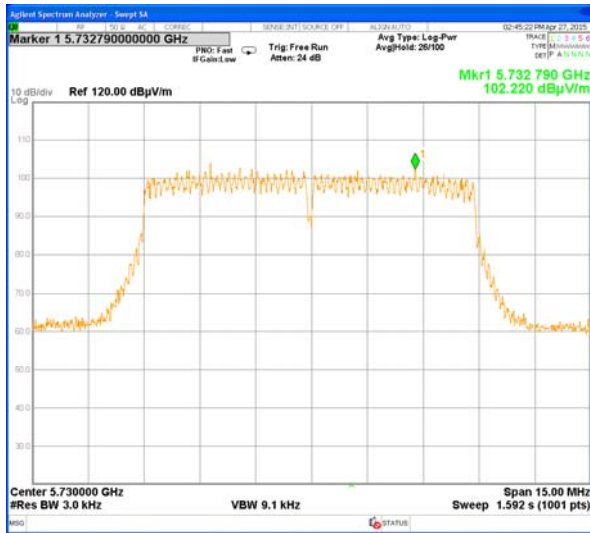

Plot # 78

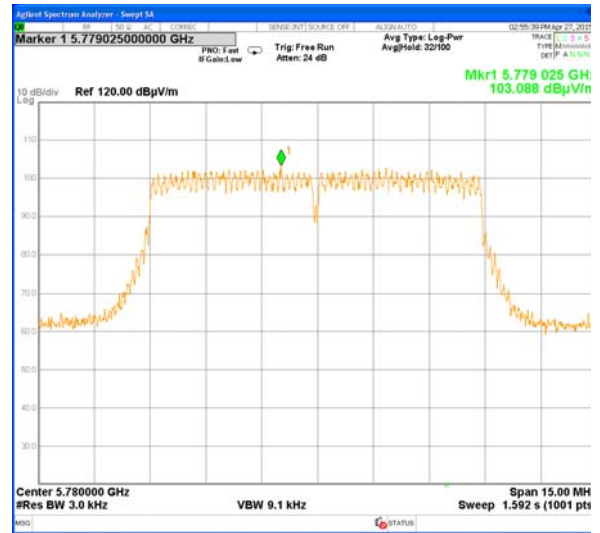

Plot # 79



Plot # 80



Test report No: 9412327172/1

Page 58 of 75 Pages

Title: 5.8 GHz Smart Antenna Outdoor Radio Device

Model: RADWIN 2000 JET/RADWIN 5000 JET

20 MHz OBW.

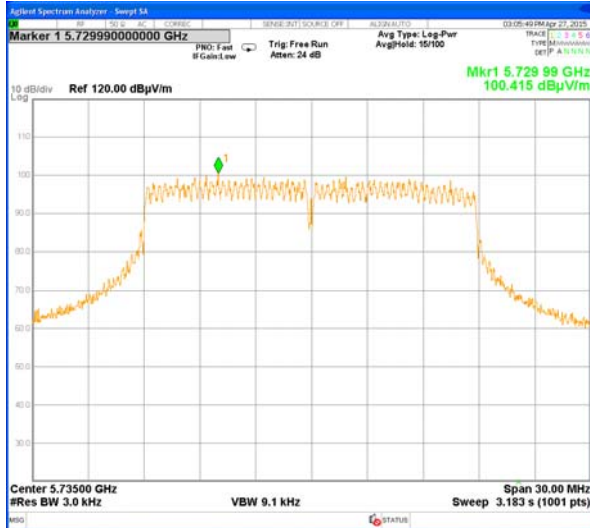

Plot # 81

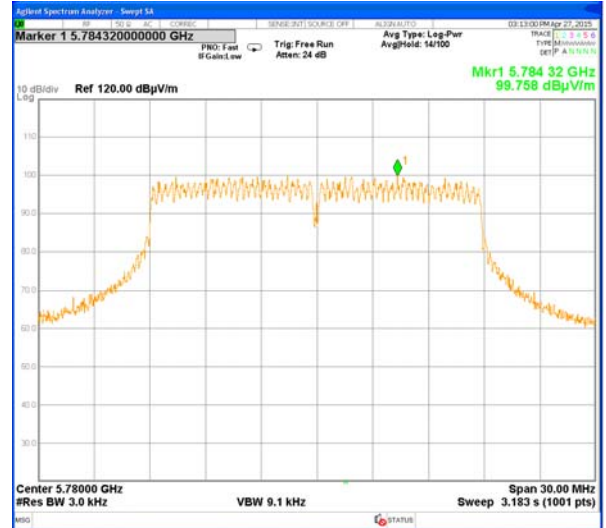

Plot # 82

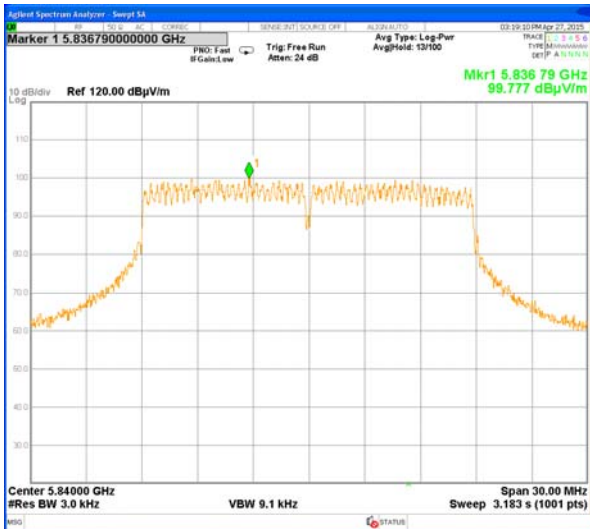

Plot # 83



Test report No: 9412327172/1

Page 59 of 75 Pages

Title: 5.8 GHz Smart Antenna Outdoor Radio Device

Model: RADWIN 2000 JET/RADWIN 5000 JET

40 MHz OBW.

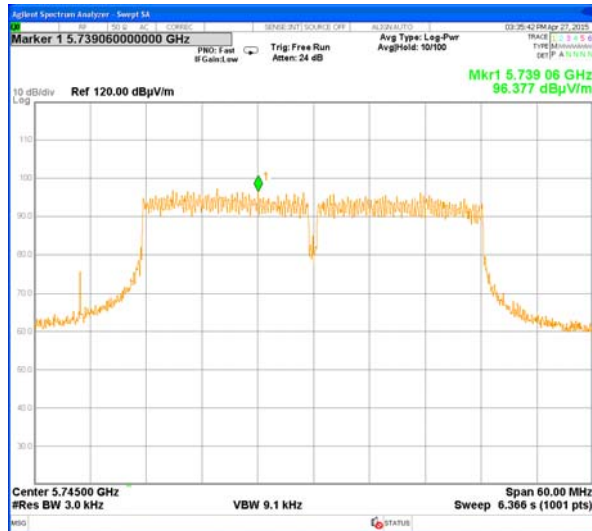

Plot # 84

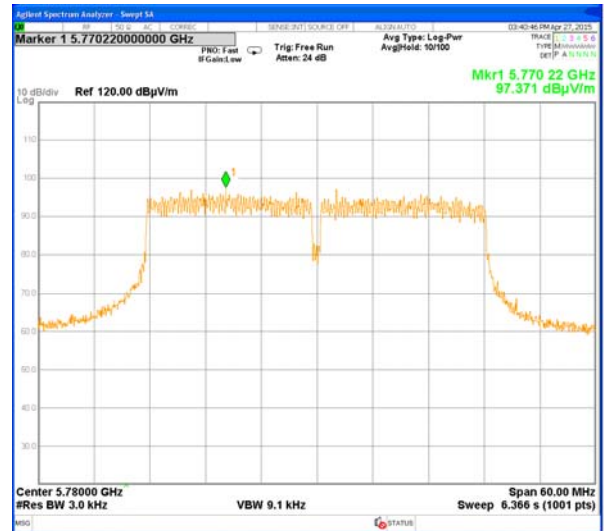

Plot # 85

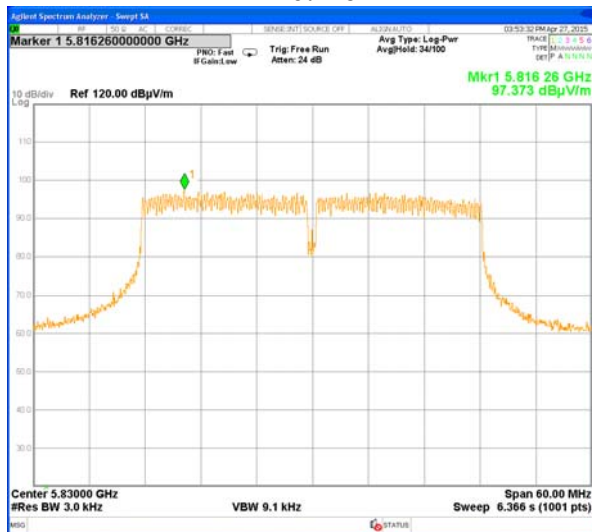

Plot # 86



Test report No: 9412327172/1

Title: 5.8 GHz Smart Antenna Outdoor Radio Device

Model: RADWIN 2000 JET/RADWIN 5000 JET

Page 60 of 75 Pages

Chain 1.

5 MHz OBW. Carrier frequency 5730 MHz.

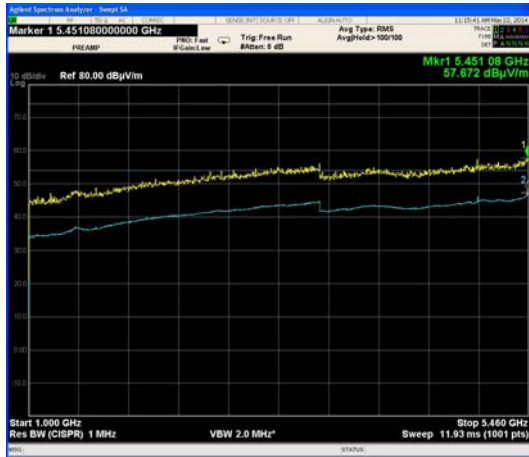

Plot # 87



Plot # 88

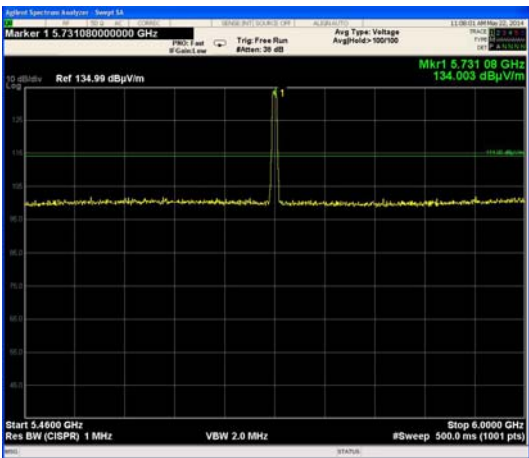

Plot # 89



Plot # 90

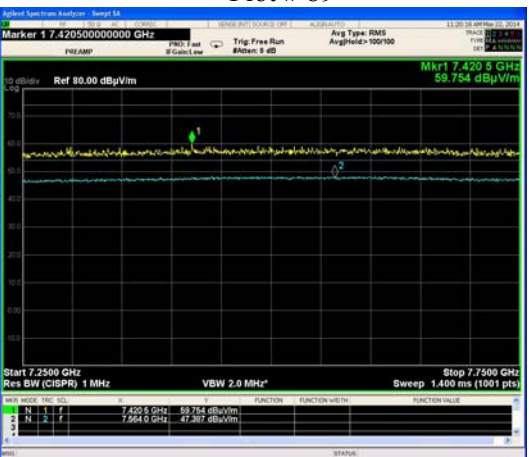

Plot # 91

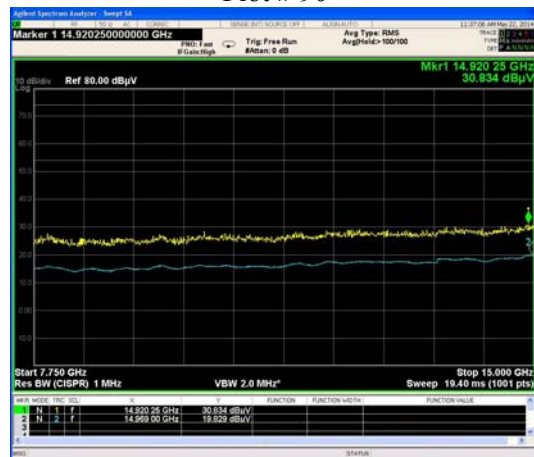

Plot # 92



Test report No: 9412327172/1

Page 61 of 75 Pages

Title: 5.8 GHz Smart Antenna Outdoor Radio Device

Model: RADWIN 2000 JET/RADWIN 5000 JET

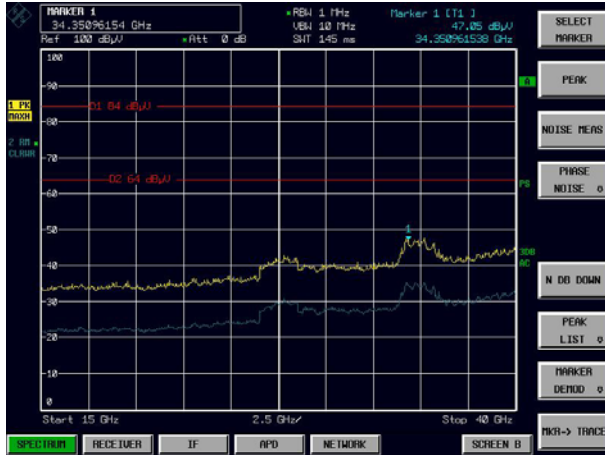

Plot # 93



Test report No: 9412327172/1

Page 62 of 75 Pages

Title: 5.8 GHz Smart Antenna Outdoor Radio Device

Model: RADWIN 2000 JET/RADWIN 5000 JET

Carrier frequency 5780 MHz.



Plot # 94

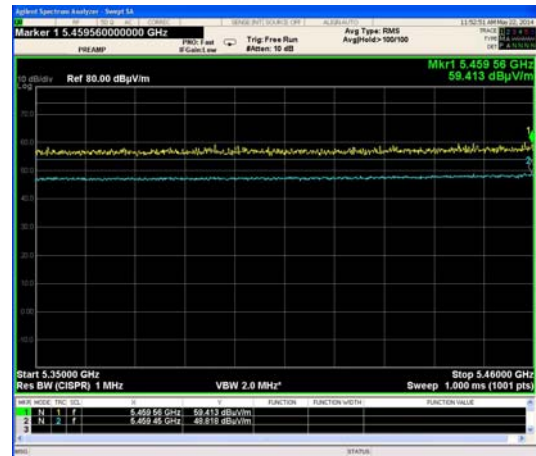

Plot # 95

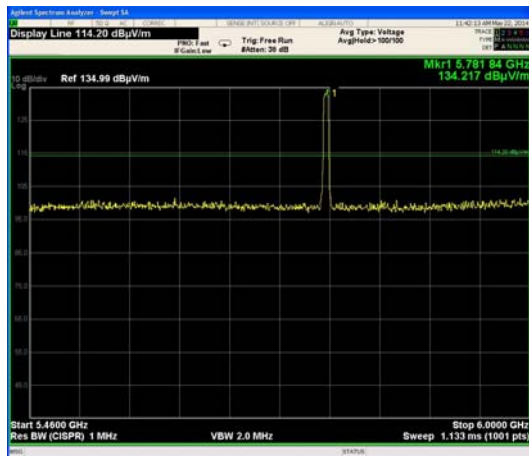

Plot # 96

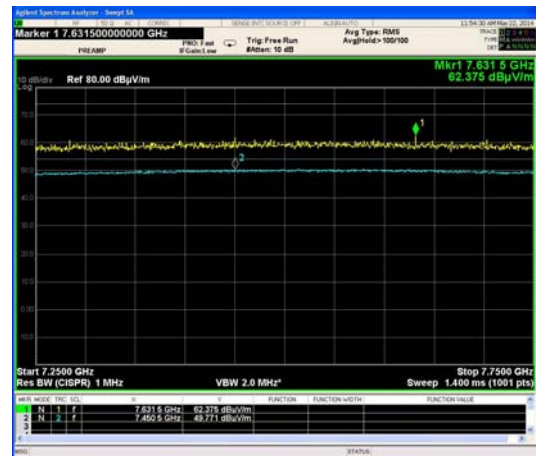

Plot # 97



Plot # 98

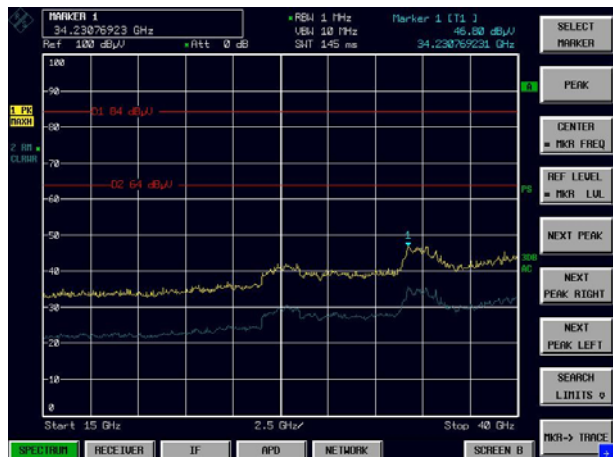

Plot # 99



Test report No: 9412327172/1

Page 63 of 75 Pages

Title: 5.8 GHz Smart Antenna Outdoor Radio Device

Model: RADWIN 2000 JET/RADWIN 5000 JET

Carrier frequency 5845 MHz.



Plot # 100

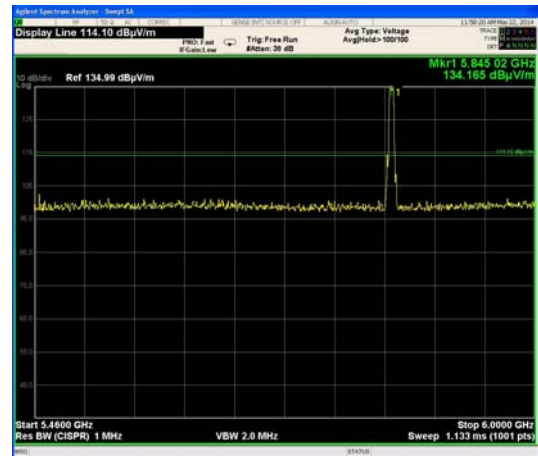

Plot # 101

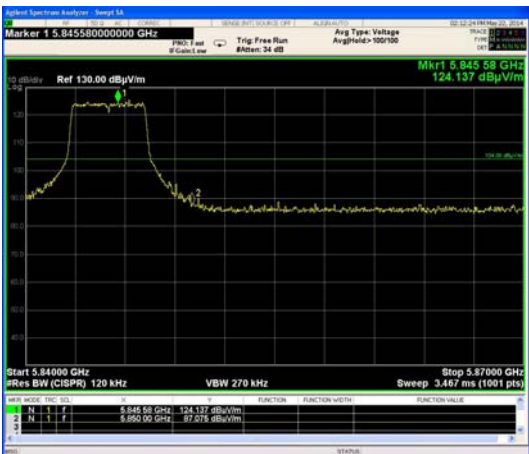

Plot # 102

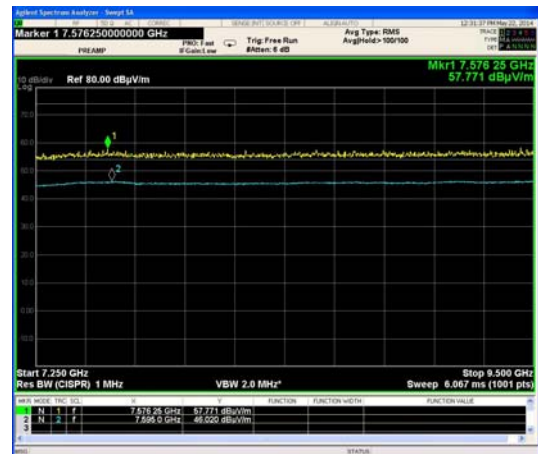

Plot # 103

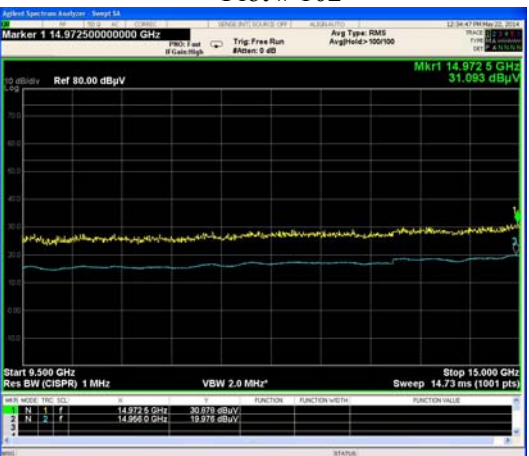

Plot # 104

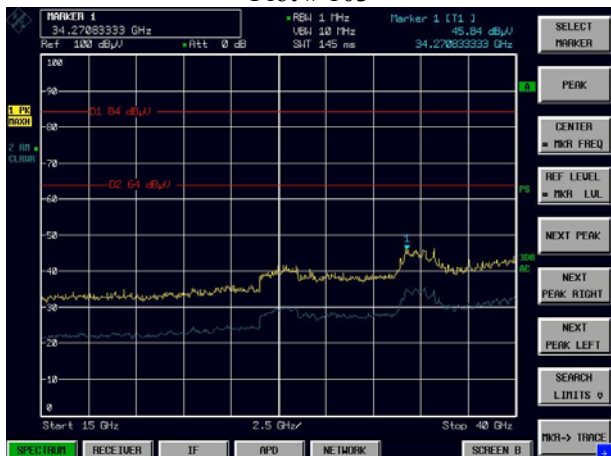

Plot # 105



Test report No: 9412327172/1

Page 64 of 75 Pages

Title: 5.8 GHz Smart Antenna Outdoor Radio Device

Model: RADWIN 2000 JET/RADWIN 5000 JET

10 MHz OBW.

Carrier frequency 5730 MHz.

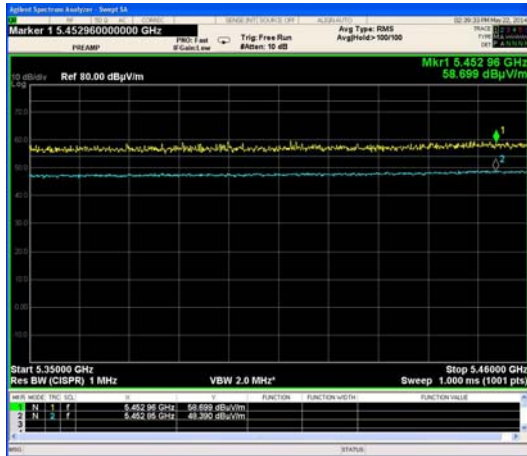

Plot # 106

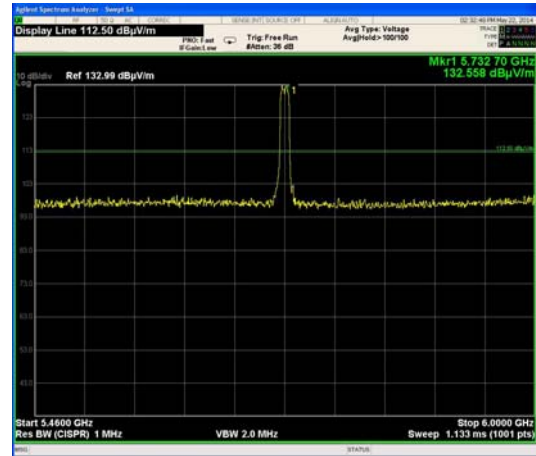

Plot # 107



Plot # 108





Test report No: 9412327172/1

Page 65 of 75 Pages

Title: 5.8 GHz Smart Antenna Outdoor Radio Device

Model: RADWIN 2000 JET/RADWIN 5000 JET

Carrier frequency 5845 MHz.

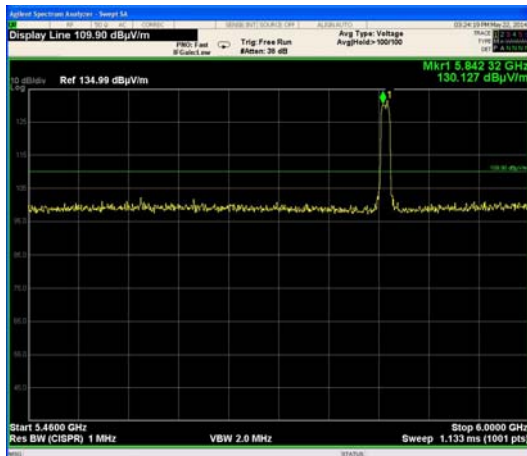

Plot # 109

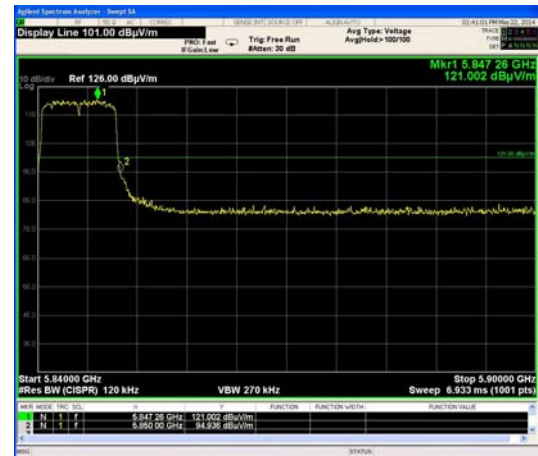

Plot # 110

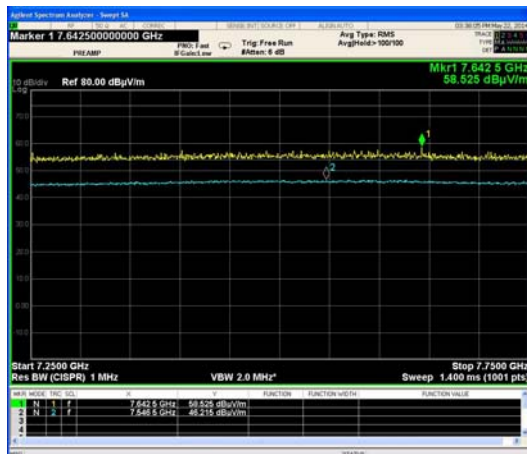

Plot # 111



Test report No: 9412327172/1

Title: 5.8 GHz Smart Antenna Outdoor Radio Device

Model: RADWIN 2000 JET/RADWIN 5000 JET

Page 66 of 75 Pages

20 MHz OBW.  
Band edge test.



Plot # 112. Carrier frequency 5735 MHz.



Plot # 113. Carrier frequency 5840 MHz.

40 MHz OBW.  
Band edge test.

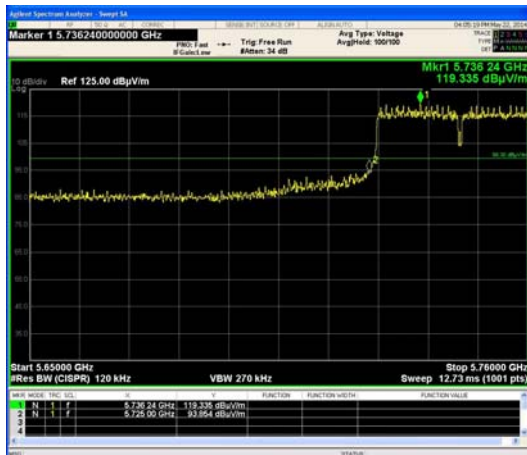

Plot # 114. Carrier frequency 5745 MHz

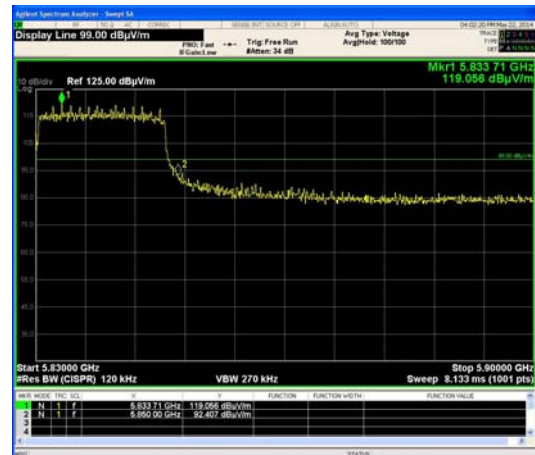

Plot # 115. Carrier frequency 5830 MHz.



Test report No: 9412327172/1

Page 67 of 75 Pages

Title: 5.8 GHz Smart Antenna Outdoor Radio Device

Model: RADWIN 2000 JET/RADWIN 5000 JET

Chain 2&3

5 MHz OBW. Carrier frequency 5730 MHz.



Plot # 116

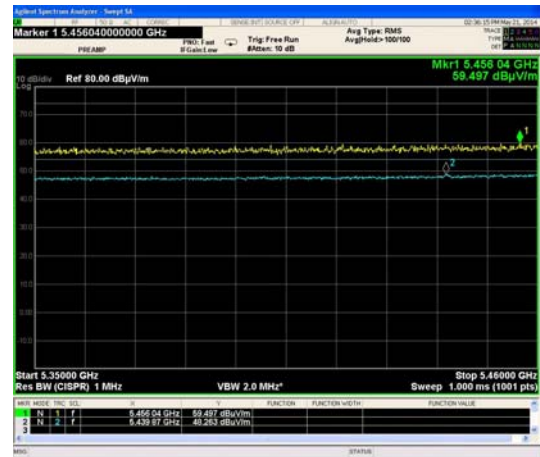

Plot # 117

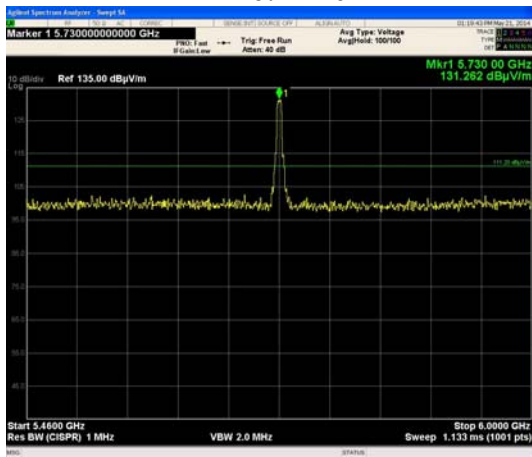

Plot # 118



Plot # 119

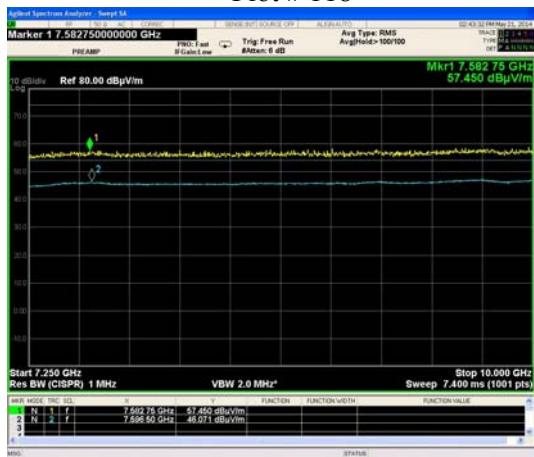

Plot # 120

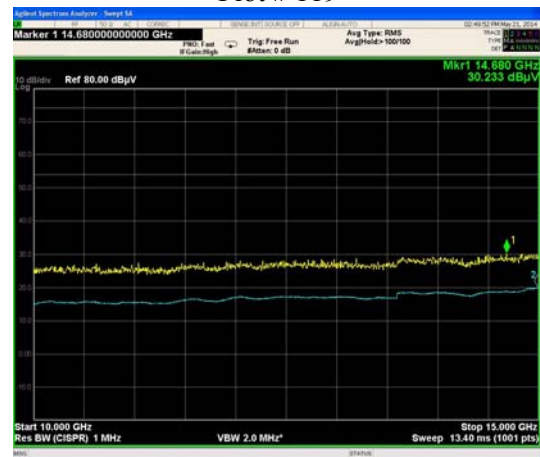

Plot # 121



Test report No: 9412327172/1

Page 68 of 75 Pages

Title: 5.8 GHz Smart Antenna Outdoor Radio Device

Model: RADWIN 2000 JET/RADWIN 5000 JET

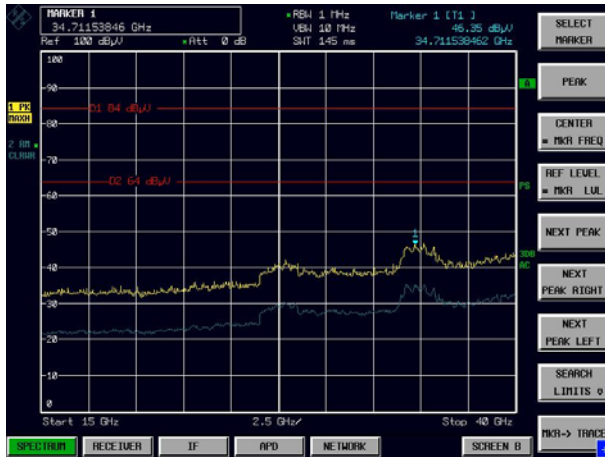

Plot # 122



Test report No: 9412327172/1

Page 69 of 75 Pages

Title: 5.8 GHz Smart Antenna Outdoor Radio Device

Model: RADWIN 2000 JET/RADWIN 5000 JET

Carrier frequency 5780 MHz.



Plot # 123

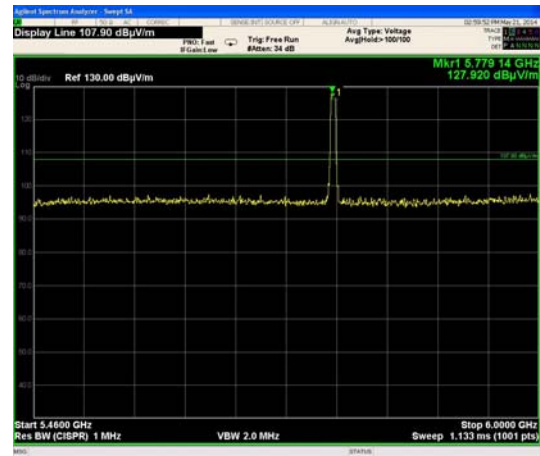

Plot # 124

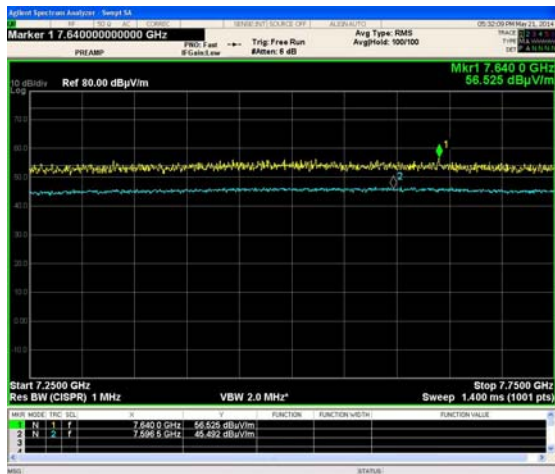

Plot # 125



Test report No: 9412327172/1

Page 70 of 75 Pages

Title: 5.8 GHz Smart Antenna Outdoor Radio Device

Model: RADWIN 2000 JET/RADWIN 5000 JET

Carrier frequency 5845 MHz.



Plot # 126

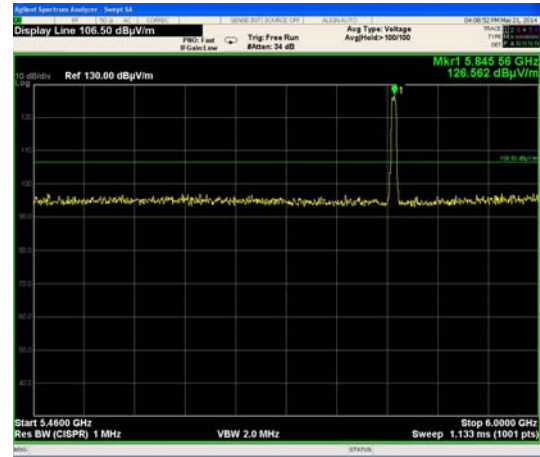

Plot # 127

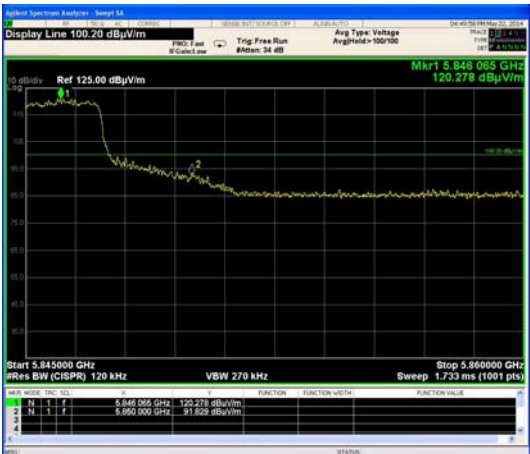

Plot # 128

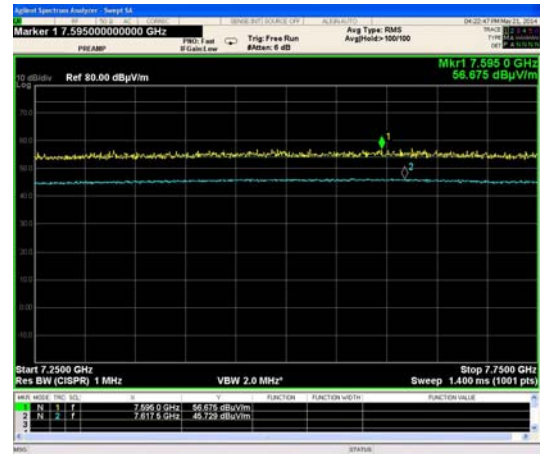

Plot # 129

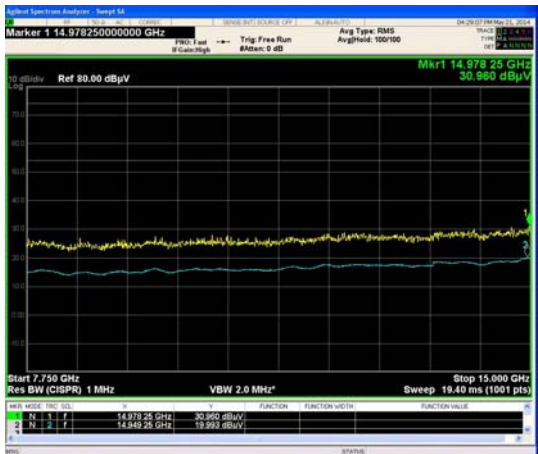

Plot # 130

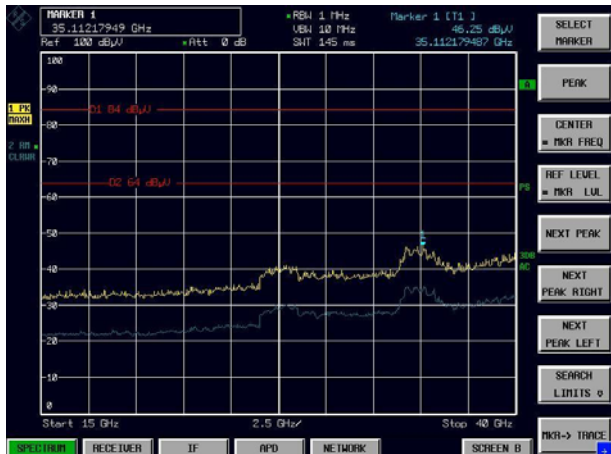

Plot # 131



Test report No: 9412327172/1

Title: 5.8 GHz Smart Antenna Outdoor Radio Device

Model: RADWIN 2000 JET/RADWIN 5000 JET

Page 71 of 75 Pages

10 MHz OBW. Carrier frequency 5730 MHz.



Plot # 132

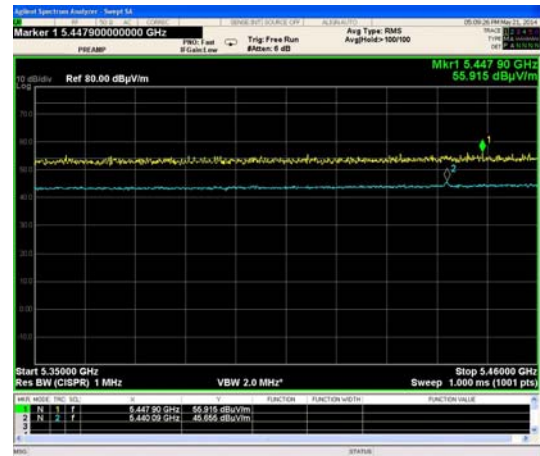

Plot # 133



Plot # 134



Plot # 135

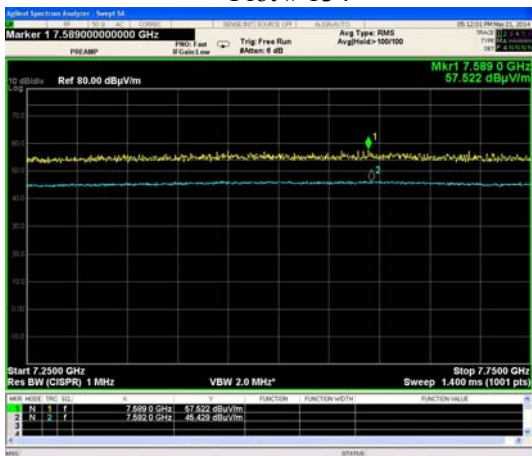

Plot # 136



Test report No: 9412327172/1

Page 72 of 75 Pages

Title: 5.8 GHz Smart Antenna Outdoor Radio Device

Model: RADWIN 2000 JET/RADWIN 5000 JET

Carrier frequency 5845 MHz.



Plot # 137

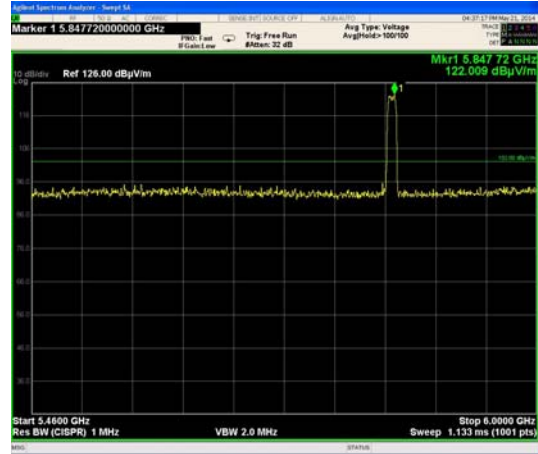

Plot # 138



Plot # 139

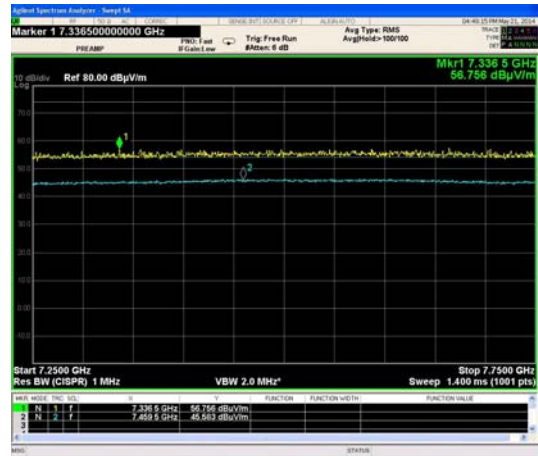

Plot # 140





Test report No: 9412327172/1

Page 73 of 75 Pages

Title: 5.8 GHz Smart Antenna Outdoor Radio Device

Model: RADWIN 2000 JET/RADWIN 5000 JET

20 MHz OBW.  
Band edge test.



Plot # 141



Plot # 142

40 MHz OBW.  
Band edge test.



Plot # 143



Plot # 144



**Test report No:** 9412327172/1

Page 74 of 75 Pages

**Title:** 5.8 GHz Smart Antenna Outdoor Radio Device

**Model:** RADWIN 2000 JET/RADWIN 5000 JET

Receiver mode spurious emission test result.



Plot # 145.



**Test report No: 9412327172/1**

**Page 75 of 75 Pages**

**Title: 5.8 GHz Smart Antenna Outdoor Radio Device**

**Model: RADWIN 2000 JET/RADWIN 5000 JET**

Radiated emission test in 0.15 MHz to 30 MHz frequency band.

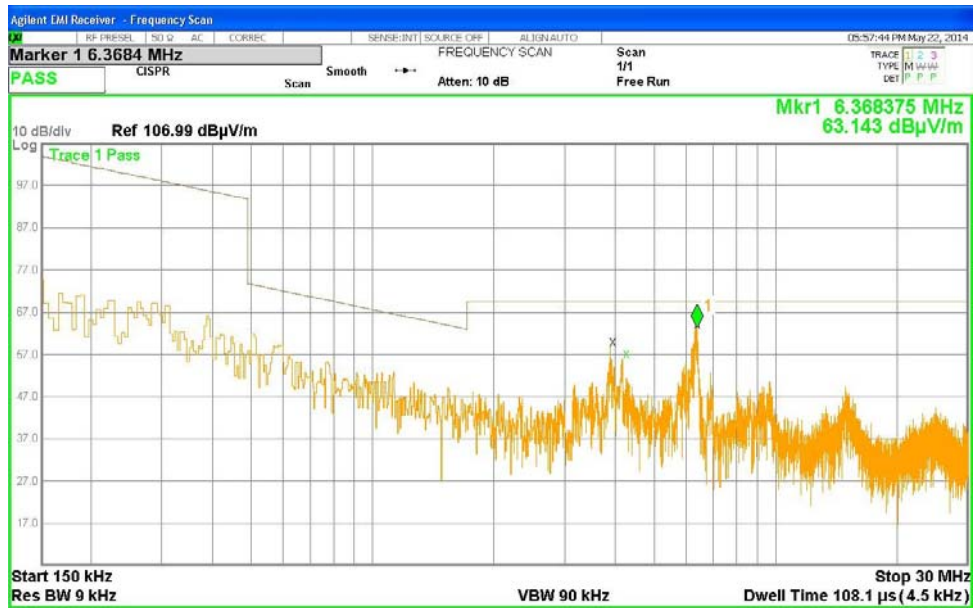

Plot # 146.