

Company: Radwin Ltd.

Test of: AP0168031 Wireless Module

To: FCC CFR 47 15.407 & ISED RSS-247

Report No.: RDWN49-U5_Master Rev A

MASTER TEST REPORT



MASTER TEST REPORT

FROM



Test of: Radwin Ltd. AP0168031 Wireless Module

To: FCC CFR 47 15.407 & ISED RSS-247

Test Report Serial No.: RDWN49-U5_Master Rev A

This report supersedes: NONE

As a result of the 6 Mbyte FCC file size limitation potentially large test reports require to be split into smaller components. This document is the Master document controlling Addendum reports as listed below. This Master document combined with the Addendums demonstrate compliance with the standard

Master Document Number	Addendum Reports
RDWN49-U5_Master	RDWN49-U5_Conducted Addendum
	RDWN49-U5_Radiated Addendum

Applicant: Radwin Ltd.
27 Habarzel Street
Tel Aviv 69710
Israel

Product Function: 5 GHz 802.11ac 3x3 RF Module

Issue Date: 17th November 2017

This Test Report is Issued Under the Authority of:

MiCOM Labs, Inc.
575 Boulder Court
Pleasanton California 94566
USA
Phone: +1 (925) 462-0304
Fax: +1 (925) 462-0306
www.micomlabs.com



MiCOM Labs is an ISO 17025 Accredited Testing Laboratory



Title: Radwin Ltd. AP0168031 Module
To: FCC CFR 47 15.407 & ISED RSS-247
Serial #: RDWN49-U5_Master Rev A
Issue Date: 17th November 2017
Page: 3 of 21

Table of Contents

1. ACCREDITATION, LISTINGS & RECOGNITION	4
1.1. TESTING ACCREDITATION.....	4
1.2. RECOGNITION	5
1.3. PRODUCT CERTIFICATION	6
2. DOCUMENT HISTORY	7
3. TEST RESULT CERTIFICATE.....	8
4. REFERENCES AND MEASUREMENT UNCERTAINTY	9
4.1. Normative References	9
4.2. Test and Uncertainty Procedure	10
5. PRODUCT DETAILS AND TEST CONFIGURATIONS	11
5.1. Technical Details	11
5.2. Scope Of Test Program	12
5.3. Equipment Model(s) and Serial Number(s)	13
5.4. Antenna Details	13
5.5. Cabling and I/O Ports	13
5.6. Test Configurations.....	13
5.7. Equipment Modifications	14
5.8. Deviations from the Test Standard	14
6. TEST SUMMARY	15
7. TEST EQUIPMENT CONFIGURATION(S)	16
7.1. Conducted	16
7.2. Radiated Emissions - 3m Chamber.....	18
8. MEASUREMENT AND PRESENTATION OF TEST DATA	20

This test report may be reproduced in full only. The document may only be updated by MiCOM Labs personnel. All changes will be noted in the Document History section of the report.

1. ACCREDITATION, LISTINGS & RECOGNITION

1.1. TESTING ACCREDITATION

MiCOM Labs, Inc. is an accredited Electrical testing laboratory per the international standard ISO/IEC 17025:2005. The company is accredited by the American Association for Laboratory Accreditation (A2LA) www.a2la.org test laboratory number 2381.01. MiCOM Labs test schedule is available at the following URL; <http://www.a2la.org/scopepdf/2381-01.pdf>



Accredited Laboratory

A2LA has accredited

MICOM LABS

Pleasanton, CA

for technical competence in the field of

Electrical Testing

This laboratory is accredited in accordance with the recognized International Standard ISO/IEC 17025:2005 General requirements for the competence of testing and calibration laboratories. This accreditation demonstrates technical competence for a defined scope and the operation of a laboratory quality management system (refer to joint ISO-ILAC-IAF Communiqué dated 8 January 2009).



Presented this 4th day of February 2016.

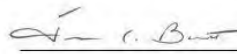

Senior Director of Quality & Communications
For the Accreditation Council
Certificate Number 2381.01
Valid to November 30, 2017

For the tests or types of tests to which this accreditation applies, please refer to the laboratory's Electrical Scope of Accreditation.

This test report may be reproduced in full only. The document may only be updated by MiCOM Labs personnel. All changes will be noted in the Document History section of the report.



1.2. RECOGNITION

MiCOM Labs, Inc has widely recognized wireless testing capabilities. Our international recognition includes Conformity Assessment Body designation by APEC MRA countries. MiCOM Labs test reports are accepted globally.

Country	Recognition Body	Status	Phase	Identification No.
USA	Federal Communications Commission (FCC)	TCB	-	US0159 Listing #: 102167
Canada	Industry Canada (IC)	FCB	APEC MRA 2	US0159 Listing #: 4143A-2 4143A-3
Japan	MIC (Ministry of Internal Affairs and Communication)	CAB	APEC MRA 2	RCB 210
	VCCI	--	--	A-0012
Europe	European Commission	NB	EU MRA	NB 2280
Australia	Australian Communications and Media Authority (ACMA)	CAB	APEC MRA 1	US0159
Hong Kong	Office of the Telecommunication Authority (OFTA)	CAB	APEC MRA 1	
Korea	Ministry of Information and Communication Radio Research Laboratory (RRL)	CAB	APEC MRA 1	
Singapore	Infocomm Development Authority (IDA)	CAB	APEC MRA 1	
Taiwan	National Communications Commission (NCC) Bureau of Standards, Metrology and Inspection (BSMI)	CAB	APEC MRA 1	
Vietnam	Ministry of Communication (MIC)	CAB	APEC MRA 1	

EU MRA – European Union Mutual Recognition Agreement.

NB – Notified Body

APEC MRA – Asia Pacific Economic Community Mutual Recognition Agreement. Recognition agreement under which test lab is accredited to regulatory standards of the APEC member countries.

Phase I - recognition for product testing

Phase II – recognition for both product testing and certification

1.3. PRODUCT CERTIFICATION

MiCOM Labs, Inc. is an accredited Product Certification Body per the international standard ISO/IEC 17065:2012. The company is accredited by the American Association for Laboratory Accreditation (A2LA) www.a2la.org test laboratory number 2381.02. MiCOM Labs test schedule is available at the following URL; <http://www.a2la.org/scopepdf/2381-02.pdf>



Accredited Product Certification Body

A2LA has accredited

MICOM LABS

Pleasanton, CA

This product certification body is accredited in accordance with the recognized International Standard ISO/IEC 17065:2012 *Requirements for bodies certifying products, processes and services*. This accreditation demonstrates technical competence for a defined scope and the operation of a management system.



Presented this 4th day of February 2016.

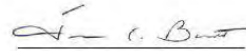

Senior Director of Quality & Communications
For the Accreditation Council
Certificate Number 2381.02
Valid to November 30, 2017

For the product certification schemes to which this accreditation applies, please refer to the organization's Product Certification Scope of Accreditation.

United States of America – Telecommunication Certification Body (TCB)
Industry Canada – Certification Body, CAB Identifier – US0159
Europe – Notified Body (NB), NB Identifier - 2280
Japan – Recognized Certification Body (RCB), RCB Identifier - 210

This test report may be reproduced in full only. The document may only be updated by MiCOM Labs personnel. All changes will be noted in the Document History section of the report.



Title: Radwin Ltd. AP0168031 Module
To: FCC CFR 47 15.407 & ISED RSS-247
Serial #: RDWN49-U5_Master Rev A
Issue Date: 17th November 2017
Page: 7 of 21

2. DOCUMENT HISTORY

Draft History		
Revision	Date	Comments
Draft	25 th October 2017	
Draft #2	13 th November 2017	

Updated Released Document History				
Master Revision/Date	Addendum Revision	Release	Date	Comments
Rev A / 17 th November 2017	Conducted	Rev A	17 th November 2017	Initial Release
	Radiated	Rev A	17 th November 2017	Initial Release

In the above table, the latest report revision will replace all earlier versions.

This test report may be reproduced in full only. The document may only be updated by MiCOM Labs personnel. All changes will be noted in the Document History section of the report.



Title: Radwin Ltd. AP0168031 Module
To: FCC CFR 47 15.407 & ISED RSS-247
Serial #: RDWN49-U5_Master Rev A
Issue Date: 17th November 2017
Page: 8 of 21

3. TEST RESULT CERTIFICATE

Manufacturer: Radwin Ltd. 27 Habarzel Street Tel Aviv 69710 Israel	Tested By: MiCOM Labs, Inc. 575 Boulder Court Pleasanton California 94566 USA
Model: AP0168031	Telephone: +1 925 462 0304 Fax: +1 925 462 0306
Type Of Equipment: 5 GHz 802.11ac 3x3 RF Module	
S/N's: Prototype	
Test Date(s): 16 th - 20 th October 2017	Website: www.micomlabs.com

STANDARD(S)	TEST RESULTS
FCC CFR 47 15.407 & IC RSS-247	EQUIPMENT COMPLIES

MiCOM Labs, Inc. tested the equipment mentioned in accordance with the requirements set forth in the above standards. Test results indicate that the equipment tested is capable of demonstrating compliance with the requirements as documented within this report.

Notes:

1. This document reports conditions under which testing was conducted and the results of testing performed.
2. Details of test methods used have been recorded and kept on file by the laboratory.
3. Test results apply only to the item(s) tested.

Approved & Released for MiCOM Labs, Inc. by:



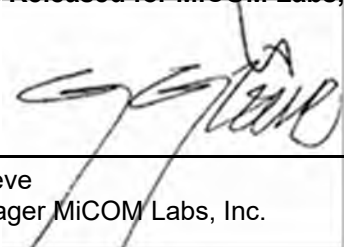

Graeme Grieve
Quality Manager MiCOM Labs, Inc.

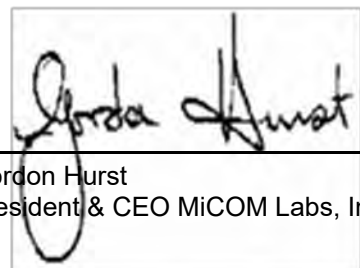

Gordon Hurst
President & CEO MiCOM Labs, Inc.

This test report may be reproduced in full only. The document may only be updated by MiCOM Labs personnel. All changes will be noted in the Document History section of the report.

4. REFERENCES AND MEASUREMENT UNCERTAINTY

4.1. Normative References

REF.	PUBLICATION	YEAR	TITLE
I	KDB 662911 D01 & D02	Oct 31 2013	Guidance for measurement of output emission of devices that employ single transmitter with multiple outputs or systems with multiple transmitters operating simultaneously in the same frequency band
II	KDB 905462 D07 v02	22nd August 2016	Test guidance to demonstrate compliance for U-NII devices subject to DFS requirements.
III	KDB 926956 D01 v02	22nd August 2016	U-NII Device Transition Plan
IV	KDB 789033 D02 v01r04	2nd May 2017	Guidelines for compliance testing of Unlicensed National Information Infrastructure (U-NII) Devices (Part 15, Subpart E)
V	A2LA	August 2017	R105 - Requirement's When Making Reference to A2LA Accreditation Status
VI	ANSI C63.10	2013	American National Standard for Testing Unlicensed Wireless Devices
VII	ANSI C63.4	2014	American National Standards for Methods of Measurement of Radio-Noise Emissions from Low-Voltage Electrical and Electronic Equipment in the Range of 9 kHz to 40 GHz
VIII	CISPR 32	2015	Electromagnetic compatibility of multimedia equipment - Emission requirements
IX	ETSI TR 100 028	2001-12	Parts 1 and 2 Electromagnetic compatibility and Radio Spectrum Matters (ERM); Uncertainties in the measurement of mobile radio equipment characteristics
X	FCC 06-96	Jun 30 2006	Memorandum Opinion and Order
XI	FCC 47 CFR Part 15.407	2016	Radio Frequency Devices; Subpart E –Unlicensed National Information Infrastructure Devices
XII	ICES-003	Issue 6 Jan 2016; Updated April 2017	Spectrum Management and Telecommunications; Interference-Causing Equipment Standard. Information Technology Equipment (Including Digital Apparatus) – Limits and methods of measurement.
XIII	M 3003	Edition 3 Nov.2012	Expression of Uncertainty and Confidence in Measurements
XIV	RSS-247 Issue 2	Feb 2017	Digital Transmission Systems (DTSS), Frequency Hopping System (FHSs) and Licence-Exempt Local Area Network (LE-LEN) Devices
XV	RSS-Gen Issue 4	November 2014	General Requirements and Information for the Certification of Radiocommunication Equipment
XVI	KDB 644545 D03 v01	August 14th 2014	Guidance for IEEE 802.11ac New Rules
XVII	FCC 47 CFR Part 2.1033	2016	FCC requirements and rules regarding photographs and test setup diagrams.

This test report may be reproduced in full only. The document may only be updated by MiCOM Labs personnel. All changes will be noted in the Document History section of the report.



Title: Radwin Ltd. AP0168031 Module
To: FCC CFR 47 15.407 & ISED RSS-247
Serial #: RDWN49-U5_Master Rev A
Issue Date: 17th November 2017
Page: 10 of 21

4.2. Test and Uncertainty Procedure

Conducted and radiated emission measurements were conducted in accordance with American National Standards Institute ANSI C63.4, listed in the Normative References section of this report.

Measurement uncertainty figures are calculated in accordance with ETSI TR 100 028 Parts 1 and 2.

Measurement uncertainties stated are based on a standard uncertainty multiplied by a coverage factor $k = 2$, providing a level of confidence of approximately 95 % in accordance with UKAS document M 3003 listed in the Normative References section of this report.

This test report may be reproduced in full only. The document may only be updated by MiCOM Labs personnel. All changes will be noted in the Document History section of the report.



Title: Radwin Ltd. AP0168031 Module
To: FCC CFR 47 15.407 & ISED RSS-247
Serial #: RDWN49-U5_Master Rev A
Issue Date: 17th November 2017
Page: 11 of 21

5. PRODUCT DETAILS AND TEST CONFIGURATIONS

5.1. Technical Details

Details	Description
Purpose:	Test of the Radwin Ltd. AP0168031 to FCC CFR 47 15.407 & ISED RSS-247. Radio Frequency Devices;
Applicant:	Radwin Ltd. 27 Habarzel Street Tel Aviv 69710 Israel
Manufacturer:	As Applicant
Laboratory performing the tests:	MiCOM Labs, Inc. 575 Boulder Court Pleasanton California 94566 USA
Test report reference number:	RDWN49-U5_Master Draft #2
Date EUT received:	16 th October 2016
Standard(s) applied:	FCC CFR 47 15.407 & IC RSS-247
Dates of test (from - to):	16 th - 20 th October 2017
No of Units Tested:	1
Product Family Name:	5 GHz 802.11ac 3x3 RF Module
Model(s):	AP0168031
Location for use:	Outdoors (Fixed Point to Point System)
Declared Frequency Range(s):	5725 - 5850 MHz;
Type of Modulation:	OFDM
EUT Modes of Operation:	10MHz; 20MHz; 40MHz; 80MHz;
Declared Nominal Output Power (dBm):	5725 – 5850 MHz: +29 dBm
Transmit/Receive Operation:	Transceiver - Full Duplex
Rated Input Voltage and Current:	POE (POE adaptor sold with unit) 55Vdc
Operating Temperature Range:	Declared Range -40°C to 60°C
ITU Emission Designator:	10 MHz 13M6W7W 20 MHz 24M6W7W 40 MHz 54M9W7W 80 MHz 111M0W7W
Equipment Dimensions:	0.3 in x 1.9 in x 2.0 in
Weight:	0.042 lb
Hardware Rev:	Prototype
Software Rev:	Prototype

This test report may be reproduced in full only. The document may only be updated by MiCOM Labs personnel. All changes will be noted in the Document History section of the report.



Title: Radwin Ltd. AP0168031 Module
To: FCC CFR 47 15.407 & ISED RSS-247
Serial #: RDWN49-U5_Master Rev A
Issue Date: 17th November 2017
Page: 12 of 21

5.2. Scope Of Test Program

Radwin Ltd. AP0168031 Wireless Module

The scope of the test program was to test the Radwin Ltd., AP0168031 configurations in the frequency ranges 5725 - 5850 MHz; for compliance against the following specification:

FCC CFR 47 Part 15 Subpart E 15.407

Radio Frequency Devices; Subpart E – Unlicensed National Information Infrastructure Devices (Fixed Point to Point System)

Industry Canada RSS-247 (Issue 2)

Digital Transmission Systems (DTSs), Frequency Hopping System (FHSs) and Licence-Exempt Local Area Network (LE-LEN) Devices

This test report may be reproduced in full only. The document may only be updated by MiCOM Labs personnel. All changes will be noted in the Document History section of the report.



5.3. Equipment Model(s) and Serial Number(s)

Type	Description	Manu.	Model	Serial no.	Delivery Date
EUT	5 GHz 802.11ac 3x3 RF Module	Radwin Ltd.	AP0168031	Prototype	16 th October 2017

5.4. Antenna Details

Type	Manufacturer	Model	Family	Gain (dBi)	BF Gain	Dir BW	X-Pol	Frequency Band (MHz)
external / slant	RADWIN LTD.	RW-9105-5158	Panel	19.0	-	17	Yes	5725 - 5850
external	RADWIN LTD.	RW-9401-5002	Omni	12.5	-	50	-	5725 - 5850

BF Gain - Beamforming Gain
Dir BW - Directional BeamWidth
X-Pol - Cross Polarization

5.5. Cabling and I/O Ports

Port Type	Max Cable Length	# Of Ports	Screened	Conn Type	Data Type
Ethernet	100m	1	Y	RJ45	Data

5.6. Test Configurations

Results for the following configurations are provided in this report:

Channel Bandwidths	Data Rate with Highest Power MBit/s	Channel Frequency (MHz)		
		Low	Mid	High
5725 - 5850 MHz				
10MHz	3.25	5730.00	5787.00	5845.00
20MHz	6.50	5735.00	5787.00	5840.00
40MHz	13.50	5745.00	5787.00	5830.00
80MHz	29.30	5765.00	5787.00	5810.00

This test report may be reproduced in full only. The document may only be updated by MiCOM Labs personnel. All changes will be noted in the Document History section of the report.



Title: Radwin Ltd. AP0168031 Module
To: FCC CFR 47 15.407 & ISED RSS-247
Serial #: RDWN49-U5_Master Rev A
Issue Date: 17th November 2017
Page: 14 of 21

5.7. Equipment Modifications

The following modifications were required to bring the equipment into compliance:

1. NONE

5.8. Deviations from the Test Standard

The following deviations from the test standard were required in order to complete the test program:

1. NONE

This test report may be reproduced in full only. The document may only be updated by MiCOM Labs personnel. All changes will be noted in the Document History section of the report.



Title: Radwin Ltd. AP0168031 Module
To: FCC CFR 47 15.407 & ISED RSS-247
Serial #: RDWN49-U5_Master Rev A
Issue Date: 17th November 2017
Page: 15 of 21

6. TEST SUMMARY

List of Measurements

Test Header	Result	Data Link
Conducted Testing	Report RDWN49-U5_Conducted	
Peak Transmit Power	Complies	
6 dB & 99% Bandwidth	Complies	
Power Spectral Density	Complies	
Radiated Testing	Report RDWN49-U5_Radiated	
TX Spurious & Restricted Band Emissions	Complies	
Restricted Edge & Band-Edge Emissions	Complies	
Digital Emissions	Report RDWN49-U5_Radiated	
Digital Emissions	Complies	
AC Wireline Emissions	Report RDWN49-U5_Radiated	
15.207 AC Wireline Emissions	Complies	

This test report may be reproduced in full only. The document may only be updated by MiCOM Labs personnel. All changes will be noted in the Document History section of the report.

7. TEST EQUIPMENT CONFIGURATION(S)

7.1. Conducted

Conducted RF Emission Test Set-up(s) The following tests were performed using the conducted test set-up shown in the diagram below.

1. Peak Transmit Power
2. Power Spectral Density
3. 6 dB & 99% Bandwidth

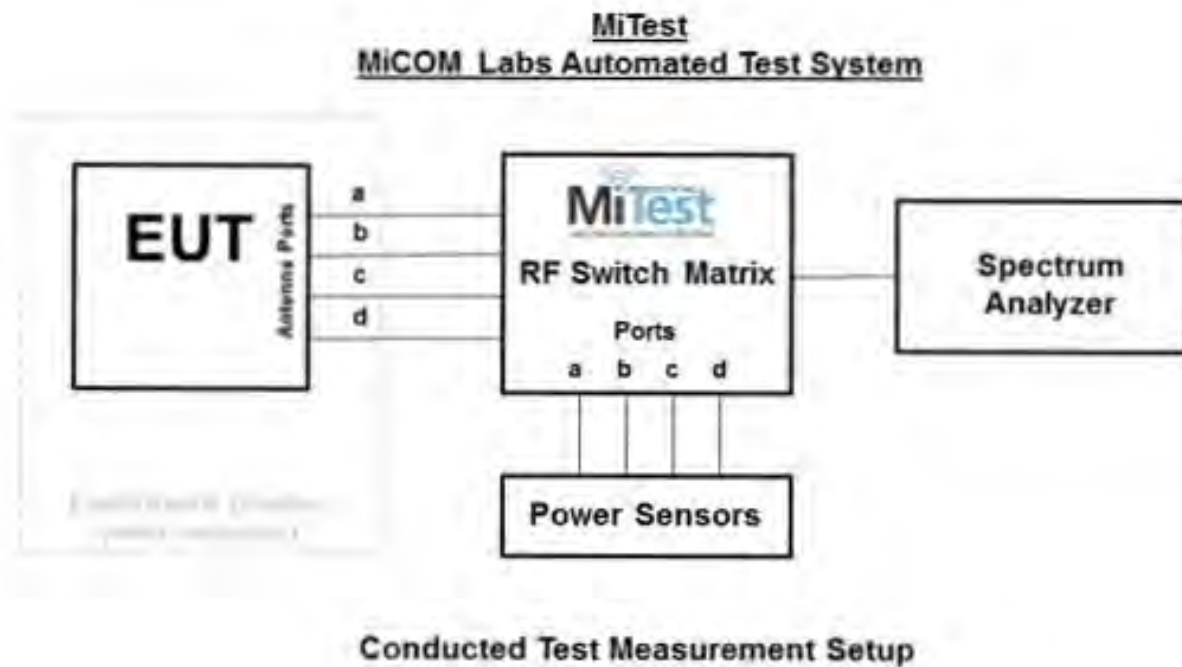

A full system calibration was performed on the test station and any resulting system losses (or gains) were taken into account in the production of all final measurement data.



Title: Radwin Ltd. AP0168031 Module
To: FCC CFR 47 15.407 & ISED RSS-247
Serial #: RDWN49-U5_Master Rev A
Issue Date: 17th November 2017
Page: 17 of 21

Asset#	Description	Manufacturer	Model#	Serial#	Calibration Due Date
127	Power Supply	HP	6674A	US36370530	Cal when used
158	Barometer/Thermometer	Control Company	4196	E2846	30 Nov 2017
248	Resistance Thermometer	Thermotronics	GR2105-02	9340 #1	30 Oct 2018
381	4x4 RF Switch Box	MiCOM Labs	MiTest RF Switch Box	MIC002	13 Nov 2017
398	MiTest RF Conducted Test Software	MiCOM	MiTest ATS	Version 4.1	Not Required
419	Laptop with Labview Software	Lenova	W520	TS02	Not Required
420	USB to GPIB Interface	National Instruments	GPIB-USB HS	1346738	Not Required
440	USB Wideband Power Sensor	Boonton	55006	9178	25 Dec 2017
442	USB Wideband Power Sensor	Boonton	55006	9181	6 Oct 2018
445	PoE Injector	D-Link	DPE-101GL	QTAH1E2000625	Not Required
460	Dell Computer with installation of MiTest executable.	Dell	Optiplex330	BC944G1	Not Required
461	Spectrum Analyzer	Agilent	E4440A	MY46185537	20 Sep 2018
493	USB Wideband Power Sensor	Boonton	55006	9634	10 Mar 2018
494	USB Wideband Power Sensor	Boonton	55006	9726	10 Mar 2018
74	Environmental Chamber Chamber 3	Tenney	TTC	12808-1	28 Sep 2018
RF#2 GPIB#1	GPIB cable to Power Supply	HP	GPIB	None	Not Required
RF#2 SMA#1	EUT to Mitest box port 1	Flexco	SMA Cable port1	None	13 Nov 2017
RF#2 SMA#2	EUT to Mitest box port 2	Flexco	SMA Cable port2	None	13 Nov 2017
RF#2 SMA#3	EUT to Mitest box port 3	Flexco	SMA Cable port3	None	13 Nov 2017
RF#2 SMA#4	EUT to Mitest box port 4	Flexco	SMA Cable port4	None	13 Nov 2017
RF#2 SMA#SA	Mitest box to SA	Flexco	SMA Cable SA	None	13 Nov 2017
RF#2 USB#1	USB Cable to Mitest Box	Dynex	USB Cable	None	Not Required

This test report may be reproduced in full only. The document may only be updated by MiCOM Labs personnel. All changes will be noted in the Document History section of the report.

7.2. Radiated Emissions

The following tests were performed using the radiated test set-up shown in the diagram below. Radiated emissions below 1GHz. Radiated Emissions above 1GHz.

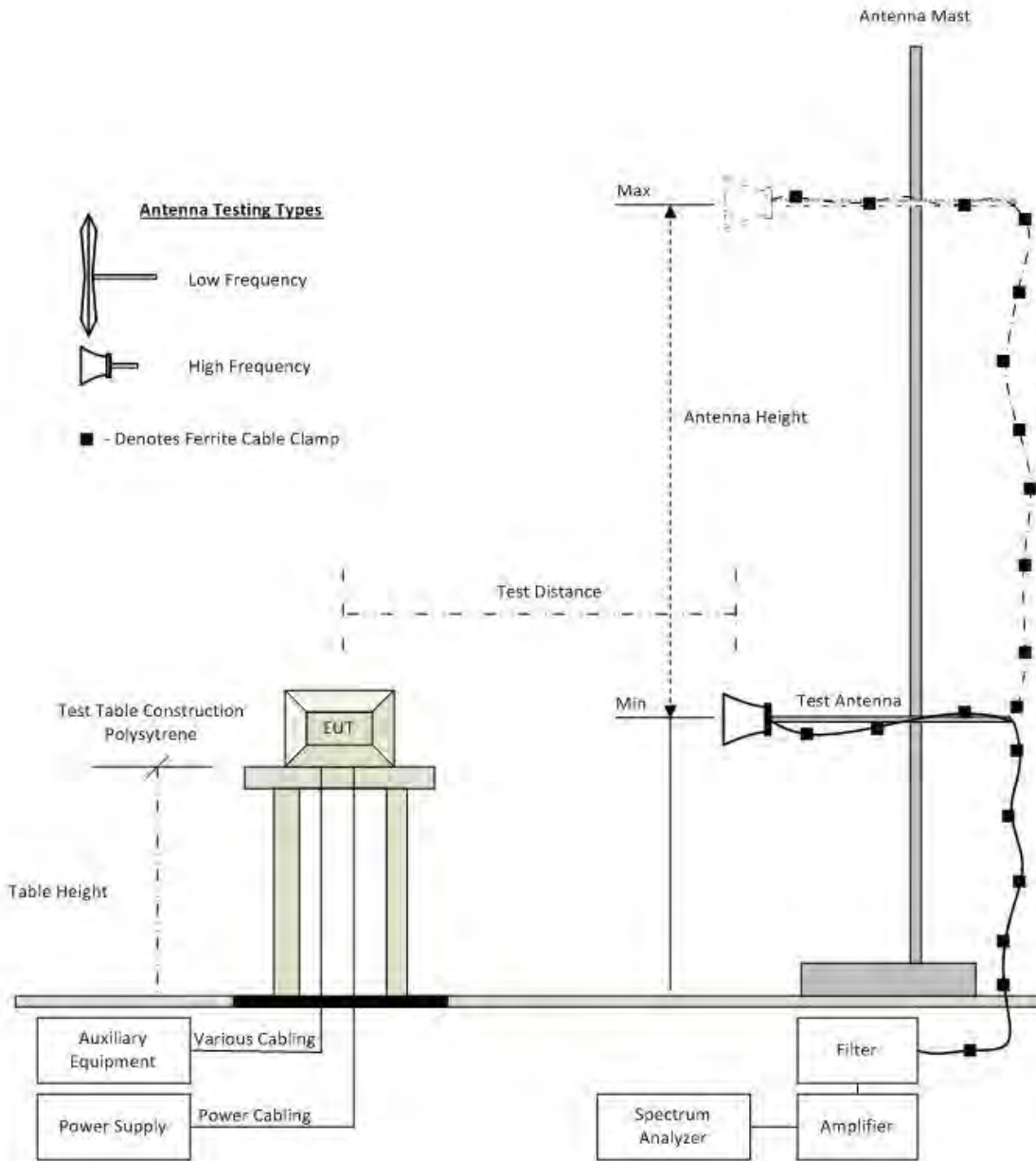

Radiated Emission Test Setup

This test report may be reproduced in full only. The document may only be updated by MiCOM Labs personnel. All changes will be noted in the Document History section of the report.



Title: Radwin Ltd. AP0168031 Module
To: FCC CFR 47 15.407 & ISED RSS-247
Serial #: RDWN49-U5_Master Rev A
Issue Date: 17th November 2017
Page: 19 of 21

A full system calibration was performed on the test station and any resulting system losses (or gains) were taken into account in the production of all final measurement data.

Asset#	Description	Manufacturer	Model#	Serial#	Calibration Due Date
158	Barometer/Thermometer	Control Company	4196	E2846	30 Nov 2017
170	Video System Controller for Semi Anechoic Chamber	Panasonic	WV-CU101	04R08507	Not Required
287	Rohde & Schwarz 40 GHz Receiver	Rhode & Schwarz	ESIB40	100201	2 May 2018
338	Sunol 30 to 3000 MHz Antenna	Sunol	JB3	A052907	5 Oct 2018
397	Amp 10 - 2500MHz	MiCOM Labs	Amp 10 - 2500 MHz	NA	30 Oct 2017
399	ETS 1-18 GHz Horn Antenna	ETS	3117	00154575	30 Oct 2017
406	Amplifier for Radiated Emissions	MiCOM Labs	40dB 1 to 18GHz Amp	0406	30 Oct 2017
410	Desktop Computer	Dell	Inspiron 620	WS38	Not Required
411	Mast/Turntable Controller	Sunol Sciences	SC98V	060199-1D	Not Required
412	USB to GPIB Interface	National Instruments	GPIB-USB HS	11B8DC2	Not Required
413	Mast Controller	Sunol Science	TWR95-4	030801-3	Not Required
415	Turntable Controller	Sunol Sciences	Turntable Controller	None	Not Required
416	Gigabit ethernet filter	ETS-Lingren	Gigafoil 260366	None	Not Required
447	MiTest Rad Emissions Test Software	MiCOM	Rad Emissions Test Software Version 1.0	447	Not Required
462	Schwarzbeck cable from Antenna to Amplifier.	Schwarzbeck	AK 9513	462	30 Oct 2017
463	Schwarzbeck cable from Amplifier to Bulkhead.	Schwarzbeck	AK 9513	463	30 Oct 2017
464	Schwarzbeck cable from Bulkhead to Receiver	Schwarzbeck	AK 9513	464	30 Oct 2017
480	Cable - Bulkhead to Amp	SRC Haverhill	157-3050360	480	30 Oct 2017
481	Cable - Bulkhead to Receiver	SRC Haverhill	151-3050787	481	30 Oct 2017
482	Cable - Amp to Antenna	SRC Haverhill	157-3051574	482	30 Oct 2017

This test report may be reproduced in full only. The document may only be updated by MiCOM Labs personnel. All changes will be noted in the Document History section of the report.

8. MEASUREMENT AND PRESENTATION OF TEST DATA

The measurement and graphical data presented in this test report was generated automatically using state-of-the-art technology creating an easy to read report structure. Numerical measurement data is separated from supporting graphical data (plots) through hyperlinks. Numerical measurement data can be reviewed without scrolling through numerous graphical pages to arrive at the next data matrix.

Plots have been relegated into the Appendix 'Graphical Data'.

Test and report automation was performed by [MiTest](#). [MiTest](#) is an automated test system developed by MiCOM Labs. [MiTest](#) is the first cloud based modular test system enabling end-to-end automation of regulatory compliance testing for conducted RF testing.



The MiCOM Labs "[MiTest](#)" Automated Test System" (Patent Pending)

This test report may be reproduced in full only. The document may only be updated by MiCOM Labs personnel. All changes will be noted in the Document History section of the report.



575 Boulder Court
Pleasanton, California 94566, USA
Tel: +1 (925) 462 0304
Fax: +1 (925) 462 0306
www.micomlabs.com